

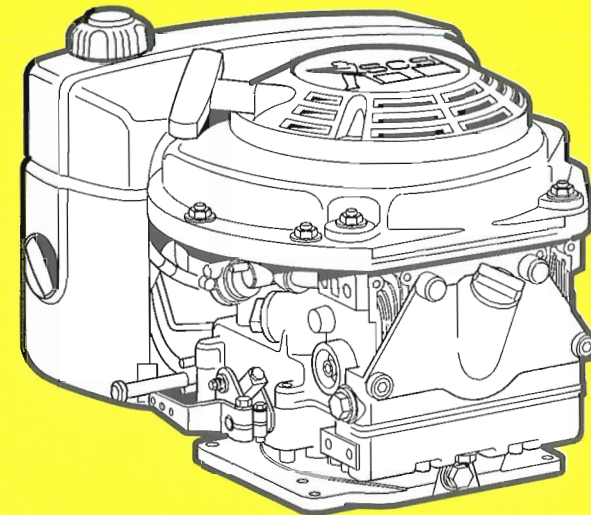

**MOTORENFABRIK HATZ • D-94099 Ruhstorf • Germany**  
Tel.: 085 31 / 3 19-0 • Telex: 57260 • Telefax: 085 31 / 31 94 18  
eMail: [hatz.marketing@t-online.de](mailto:hatz.marketing@t-online.de) • <http://www.hatz.com>

**Original-Ersatzteile**  
**Original-spare parts**  
**Pièces de rechange d'origine**  
**Repuestos originales**  
**Pezzi di ricambio originali**



**1B20 V**

43480071 - 10.99 - 0.2  
Printed in Germany  
**DM 3.50**

# Bestellung für HATZ-Original-Ersatzteile

Order for HATZ Original spare parts  
 Commande de pièces d'origine HATZ  
 Pedido de repuestos originales HATZ  
 Ordine parti di ricambio originali HATZ

1

Besteller / Customer / Client / Cliente / Cliente

2

TYP	KENNZ.	
MOTOR/FABRIK NO.		
MIN <sup>-1</sup>		

3

Ersatzteilliste Nr./ Spare parts list no./ Liste des pièces de rechange no./ Lista de repuestos No./ Lista ricambi n.

**1 B 20 V . 11**

4

Stück / Qty / Q.tà	HATZ Ident No.	Stück / Qty / Q.tà	HATZ Ident No.

5

Versandart / Mode of dispatch / Mode d'expédition / Despacho deseado / Modo di spedizione

Post / Surface / Poste / Correo / Posta  Luftfracht / airfreight / frêt aérien / flete aereo / Via aerea   
 Express / express / exprès / expreso / Espresso  .....

6

Versandadresse / Consignee / Adresse destination / Dirección / Indirizzo di destinazione

- Bestellung an: Order at: Commande à: Pedido a:
- die nächste HATZ-Servicestelle (siehe Servicestellenverzeichnis)
  - your nearest HATZ service station (see service-list)
  - votre station-service HATZ la plus proche (voir liste "Service")
  - al servicio HATZ más cercano (ver cuaderno de Servicio)
  - al più vicino centro di servizio HATZ (vedi lista centri autorizzati)

**MOTORENFABRIK HATZ**  
**D-94099 RUHSTORF**  
 Tel: 0 85 31 / 319 - 0  
 Fax: 0 85 31 / 31 94 21

	<b>Inhaltsverzeichnis</b>	<b>Index</b>	<b>Tafel Nr. Table No.</b>
<b>M ..</b>	<b>Grundmotor</b>	<b>Basic engine</b>	
00	Ersatzteilsätze	Spare part kits	01
34	Zubehör	Accessories	02
01	Kurbelgehäuse	Crankcase	03
02	Kurbelwelle	Crankshaft	04
04	Nockenwelle	Camshaft	05
05, 06	Kolben, Pleuel, Zylinder	Piston, conrod, cylinder	06
07	Zylinderkopf	Cylinder head	07
10, 32	Ölpumpe, Regler	Oil pump, governor	
	Drehzahlverstellung	speed control	08
11	Steuerdeckel	Timing cover	09
13,17	Gebläse, Schwungrad	Blower, flywheel	10
14	Einspritzausrüstung	Injection equipment	11
15	Reversierstarter	Recoil starter	12
26	Luftführung 1 B 20	Air ducting 1 B 20	13
31	Kurbelgehäuseentlüftung	Crankcase breathing system	14
<b>A ..</b>	<b>Zusatzausrüstung</b>	<b>Equipments</b>	
01	Kraftstoffbehälter	Fuel tank	15
02	Luftfilter	Air filter	16
03	Abgasdämpfer 1 B 20	Exhaust silencer 1 B 20	17
05	Starter,Generator,	Starter, alternator,	18
05, 10	Armaturen, Leitungen	Electric equipment, wirings	19

	<b>Sommaire:</b>	<b>Indice</b>	
<b>M ..</b>	<b>Moteur de base</b>	<b>Motor de base</b>	
00	Jeu de pièces de rechange	Juegos de piezas de recambios	01
34	Accessoires	Accesorios	02
01	Carter moteur	Caja cigueñal	03
02	Vilebrequin	Cigüeñal	04
04	Arbre à cames	Arbol de levas	05
05, 06	Piston, bielle, cylindre	Émbolo, biela, cilindro	06
07	Culasse	Culata	07
10, 32	Pompe à huile, regulateur regime, réglage regime	Bomba de aceite, regulador, ajuste de revoluciones	08
11	Couvercle distribution	Tapa de mando	09
13,17	Soufflerie, volant	Ventilador, volante	10
14	Equipment d'injection	Equipo de inyección	11
15	Demarreur reversible	Arrancador reversible	12
26	Carter ventilation 1 B 20	Conducción de aire 1 B 20	13
31	Reniflard	Purgador	13
<b>A ..</b>	<b>Accessoires</b>	<b>Equipos</b>	
01	Reservoir à carburant	Depósito combustible	15
02	Filtre à air	Filtro de aire	16
03	Silencieux 1 B 20	Silenciador 1 B 20	17
05	Demarreur, alternateur	Arrancador, alternador	18
05, 10	Equipement électrique, cable	Equipo eléctrico, cables	19

M ..	Motore de base	
00	Serie guarnizioni	01
34	Kit accessori	02
01	Basamento motore	03
02	Albero a gomito	04
04	Albero a camme	05
05, 06	Pistone, biella, cilindro	06
07	Testa	07
10, 32	Pompa olio, regolatore di giri, Comando acceleratore	08
11	Coperchio distribuzione	09
13, 17	Ventilatore, volano	10
14	Equipaggiamento di iniezione	11
15	Avviamento a strappo	12
26	Carter ventilatore 1 B 20	13
31	Sfiato basamento	14

A ..	Accessori	
01	Serbatoio	15
02	Filtro aria	16
03	Scarico 1 B 20	17
05	Motorino avviamento, alternatore,	18
05, 10	Equipaggiam. elettrico, cablaggio	19

**M 00** Ersatzteilsätze  
Spare part kits  
Jeux de pièces de rechange  
Juegos de piezas de recambios  
Serie guarnizioni

Tafel Nr.  
Tabl. No.  
Tavola N.

**01**

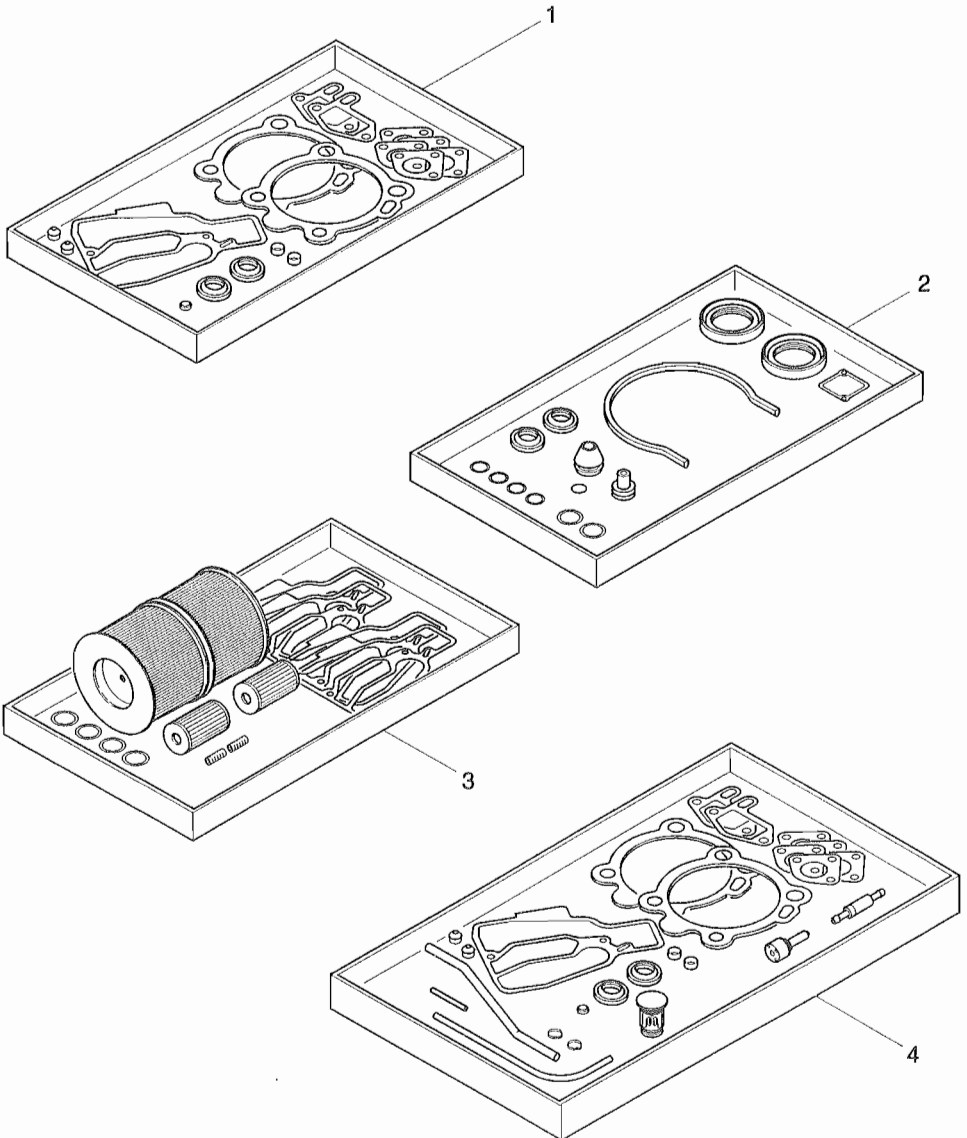

Fig.-No.	HATZ Ident-No.	Stück Qty.	P / W d / D	Bemerkungen Notes
1B20V				
				<p>W: Im Wartungssatz enthalten. Incl. in maintenance kit. Contenu dans le jeu d'entretien. Incluido en el juego de mantenimiento. Contenuto nella serie manutenzione.</p> <p>d: Im Dichtungssatz f. 1 Zyl.-Kopf enthalten. Incl. in gasket set f. 1 cyl. head. Contenu dans le jeu de joint p. 1 culasse. Incluido en el juego de juntas p. 1 culata. Contenuto nella serie guarnizioni p. 1 testa.</p> <p>P: Im Pannensatz enthalten. Incl. in emergency kit. Contenu dans le jeu secur. Incluido en el juego para averias. Contenuto nella serie di prima necessità.</p> <p>D: Im Dichtungssatz Kurbelgeh. Incl. in gasket set crankcase. Contenu dans le jeu de joints carter moteur. Incluido en el juego de juntas caja cigueñal. Contenuto nella serie guarnizioni basamento.</p> <p>1: Anzahl pro Satz - Qty. per kit Quantite p. jeu - Cantidad p. juego. Quantità per serie</p>
1	015 541 00	1	P 1	Dichtungssatz für 1 Zylinderkopf Gasket set for 1 cyl. head Jeu de joint p. 1 culasse Juego de juntas para 1 culata Serie guarniziono per 1 testa
2	015 542 00	1		Dichtungssatz für Kurbelgehäuse Gasket set for crankcase Jeu de joints p. carter moteur Juego de juntas para caja cigueñal Serie guarnizioni basamento
3	015 543 00	1		Wartungssatz für 1000 h 1000 hours maintenance kit Kit d'entretien 1000 heures - Juego de piezas para servicio 1000 horas Kit di manutenzione a 1000 ore
4	015 544 00	1		Pannensatz - Emergency kit Kit de secours - Juego para averias Kit di prima necessità





Fig.-No.	HATZ Ident-No.	Stück Qty.	P / W d / D	Bemerkungen Notes
1B20V				
1	013 310 01	1		Zubehörsatz - Accessoires kit Sort. accessoires Juego de accesorios Serie accessorie
2	051 104 01	1		160 x 67 mm
3	051 300 00	1		
4	051 301 00	1		

Dicht- und Klebstoffe Sealing- and bonding adhesives Etanchéifiant et Colle			Materias para empaquetar y pegar Adesivi e collanti	
A =	502 230 01	Loctite Activator N	500 ml	} siehe Hinweis auf den einzelnen Bildtafeln  } as specified in the individual tables  } suivant les remarques sur les tableau correspondant  } según las indicaciones de las tablas correspondientes  } seguire le indicazioni sul quadro corrispondente
B =	502 231 00	Loctite 573	50 ml	
C =	502 232 00	Loctite 601	50 ml	
D =	502 233 00	Loctite 221	50 ml	
E =	502 234 00	Loctite 648	10 ml	
F =	502 238 00	Technicoll 8058	0,75 kg	
+	502 239 00	Technicoll 8367	0,75 kg	
G =	502 565 01	Loctite IS 407	20 g	
H =	502 825 01	Silicon	30 ml	
J =	502 830 03	Hochtemp. Paste	100 ml	
K =	503 426 00	Hochtemp. Fett	100 g	
L =	502 566 00	Silicon sealer	100 g	
M =	504 851 00	Schleifpaste	80 g	

M 01

Kurbelgehäuse 1B20V  
Crankcase 1B20V  
Carter moteur 1B20V  
Caja cigueñal 1B20V  
Basamento motore 1B20V

Tafel Nr.  
Tabl. No.  
Tavola N.

03

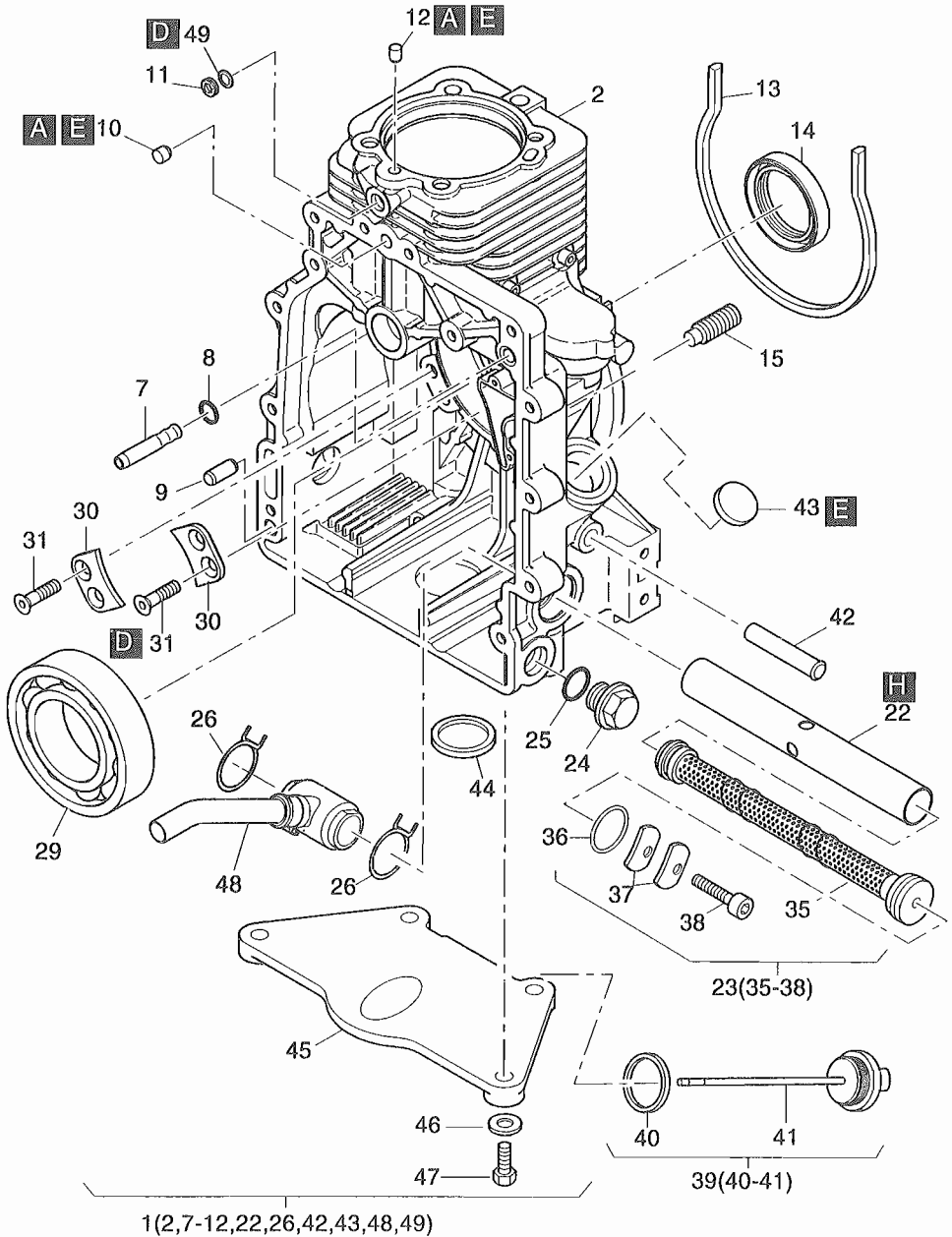

Fig.-No.	HATZ Ident-No.	Stück Qty.	P / W d / D	Bemerkungen Notes
		1B20V		
1	016 250 10	1		
2	-----	-		
7	050 843 00	1		
8	504 403 00	1	D1	8 x 1,5
9	502 491 01	1		8 m 6 x 20
10	-----	-		
11	500 623 00	1		M 10 x 1 DIN 908-5.8 A3C
12	-----	-		
13	040 980 00	1	D1	315 mm
14	504 232 00	1	D1	40 x 55 x 10 AS
15	041 152 00	1		M 12 x 1,5 x 35 45 H A3C TUF 360
22	041 057 10	1		
23	015 427 02	1		
24	503 731 00	1	W1	AM 22 x 1,5 MAGN.
25	504 698 00	1	D2, W4	A 22 x 27 DIN 7603 - Vf
26	050 369 00	2		
29	504 233 00	1		
30	040 944 00	2		
31	503 280 00	4		AM 6 x 16 17065-8.8 Zn
35	-----	-		
36	504 759 01	1		20 x 4
37	051 482 00	2		
38	501 707 00	1		M 6 x 16 DIN 912-8.8 A3C
39	013 392 00	1		
40	041 250 00	1		26 x 35 x 3
41	-----	-		
42	-----	-		
43	-----	-		
44	503 292 00	1		50 x 55 x 3
45	051 444 00	1		
46	501 157 00	4		8,4 DIN 433-St 140 HV
47	503 663 00	4		M 8 x 20 DIN 912-8.8 A3C
48	013 398 00	1		
49	500 624 00	1		A 10 x 13,5 DIN 7603-Cu

M 02

Kurbelwelle  
Crankshaft  
Vilebrequin  
Cigüeñal  
Albero a gomito

Tafel Nr.  
Tabl. No.  
Tavola N.

04

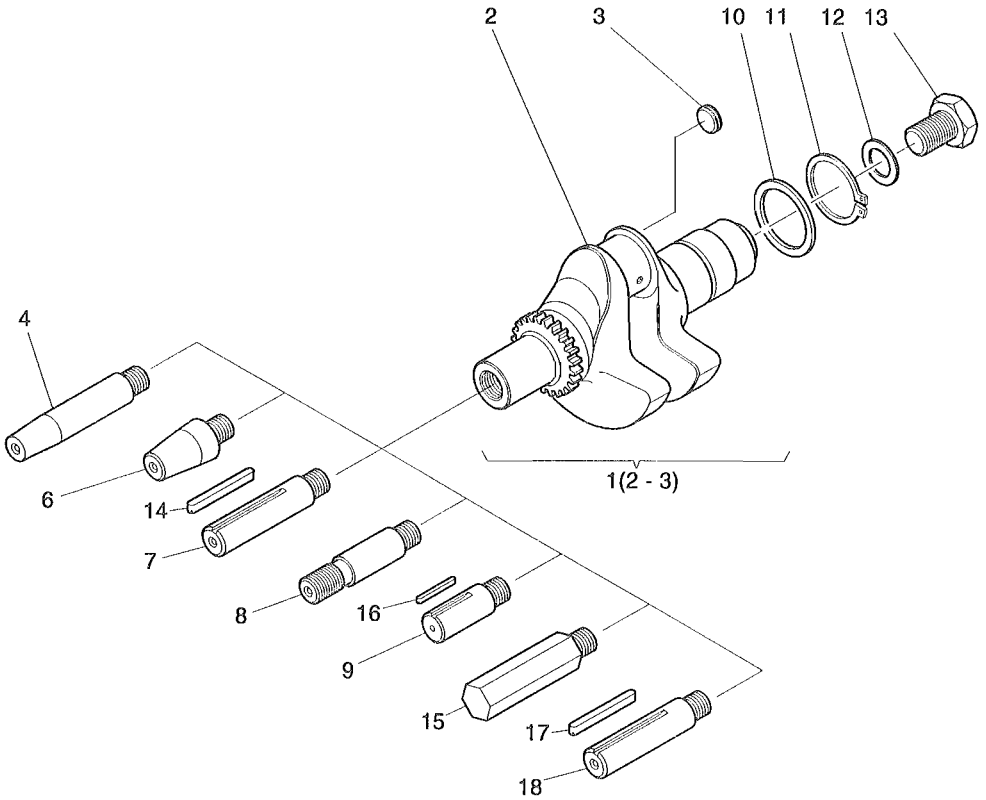

Fig.-No.	HATZ Ident-No.	Stück Qty.	P / W d / D	Bemerkungen Notes
		1B20V		
1	013 403 00	1		1 B 20 V „X“
2	-----	-		
3	041 253 00	1		
4	050 996 00	1		Nr. 4 SAE Generator
5	-----	-		
6	050 997 00	1		Nr. 6 ital. 23 keg., con.
7	050 998 00	1		Nr. 7 3/4" zyl., cil.
8	050 999 00	1		Nr. 8 SAE 3/4 - 16 UNF
9	051 000 00	1		Ø 20 zyl., cil.
10	400 325 00	1		40 x 50 x 2,5     DIN 988
11	501 206 00	1		A 40 x 1,75     DIN 471
12	041 142 01	1		18,5 x 37 x 5
13	504 436 00	1		M 18 x 1,5 x 55   DIN 961-10.9
14	041 204 00	1		4,75 x 30
15	051 073 01	1		27 mm
16	504 634 00	1		A 5 x 5 x 36     DIN 6885
17	504 634 00	1		A 5 x 5 x 36     DIN 6885
18	041 525 00	1		

M 04

Nockenwelle  
Camshaft  
Arbre à cames  
Arbol de levas  
Albero a camme

Tafel Nr.  
Tabl. No.  
Tavola N.

05

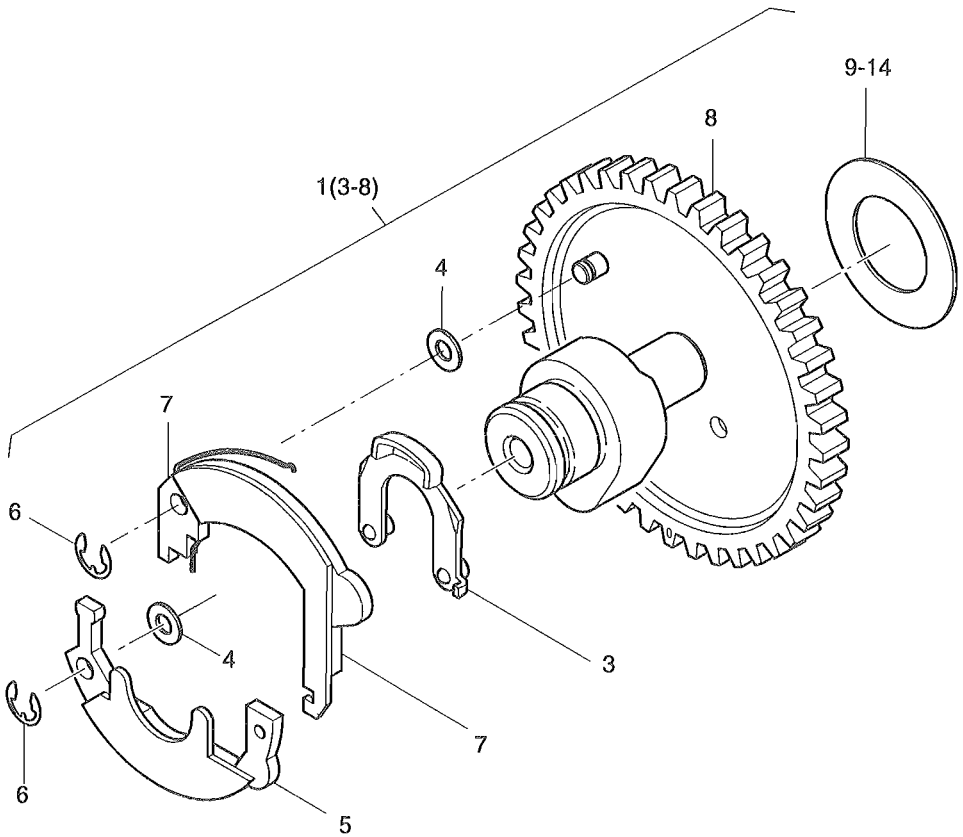

Fig.-No.	HATZ Ident-No.	Stück Qty.	P / W d / D	Bemerkungen Notes
		1B20V		
1	016 404 00	0...1		Handstart
1	016 403 00	0...1		E - Start
2	-----	-		
3	013 264 00	1		
4	501 232 00	2		5 x 10 x 0,5      DIN 988
5	013 266 00	1		
6	502 553 00	2		3,2                  DIN 6799
7	013 265 00	1		
8	-----	-		
9	041 217 00	0...1		0,9 mm      23 x 38 x 0,9
10	041 121 00	0...1		1,0 mm      23 x 38 x 1,0
11	041 122 00	0...1		1,1 mm      23 x 38 x 1,1
12	041 123 00	0...1		1,2 mm      23 x 38 x 1,2
13	041 251 00	0...1		1,3 mm      23 x 38 x 1,3
14	041 252 00	0...1		1,4 mm      23 x 38 x 1,4

**M 05**

Kolben, Pleuel  
Piston, Conrod  
Piston, bielle  
Embolo, biela  
Pistone, biella

**M 06**

Zylinder  
Cylinder  
Cylindre  
Cilindro  
Cilindro

**06**

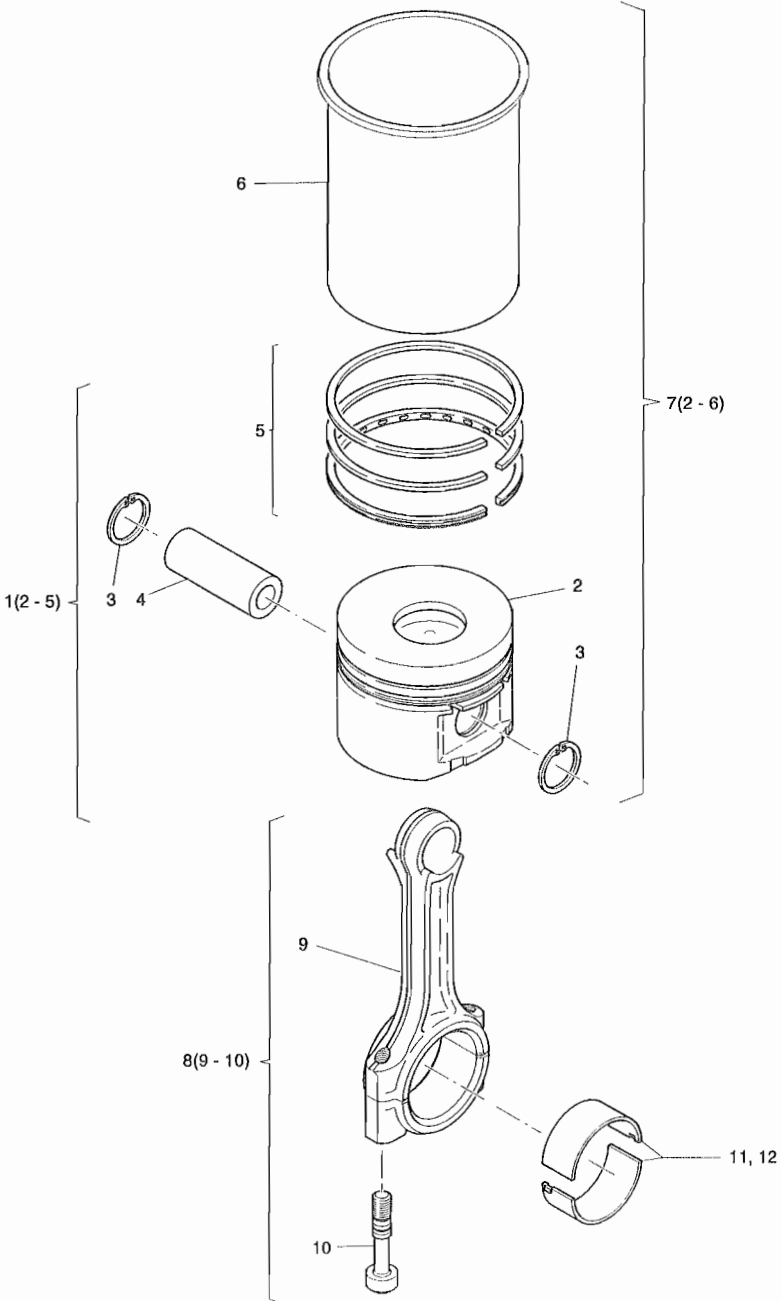



Fig.-No.	HATZ Ident-No.	Stück Qty.	P / W d / D	Bemerkungen Notes
		1B20V		
1	013 171 00	1		69 mm
2	-----	-		
3	504 255 00	2		
4	-----	-		
5	013 172 00	1		
6	-----	-		
7	015 545 00	1		
8	015 001 00	1		
9	-----	-		
10	050 469 00	2		
11	015 757 00	1		
12	015 819 00	1		-0,5 mm

# M 07

Zylinderkopf  
 Cylinder head  
 Culasse  
 Culata  
 Testa

07

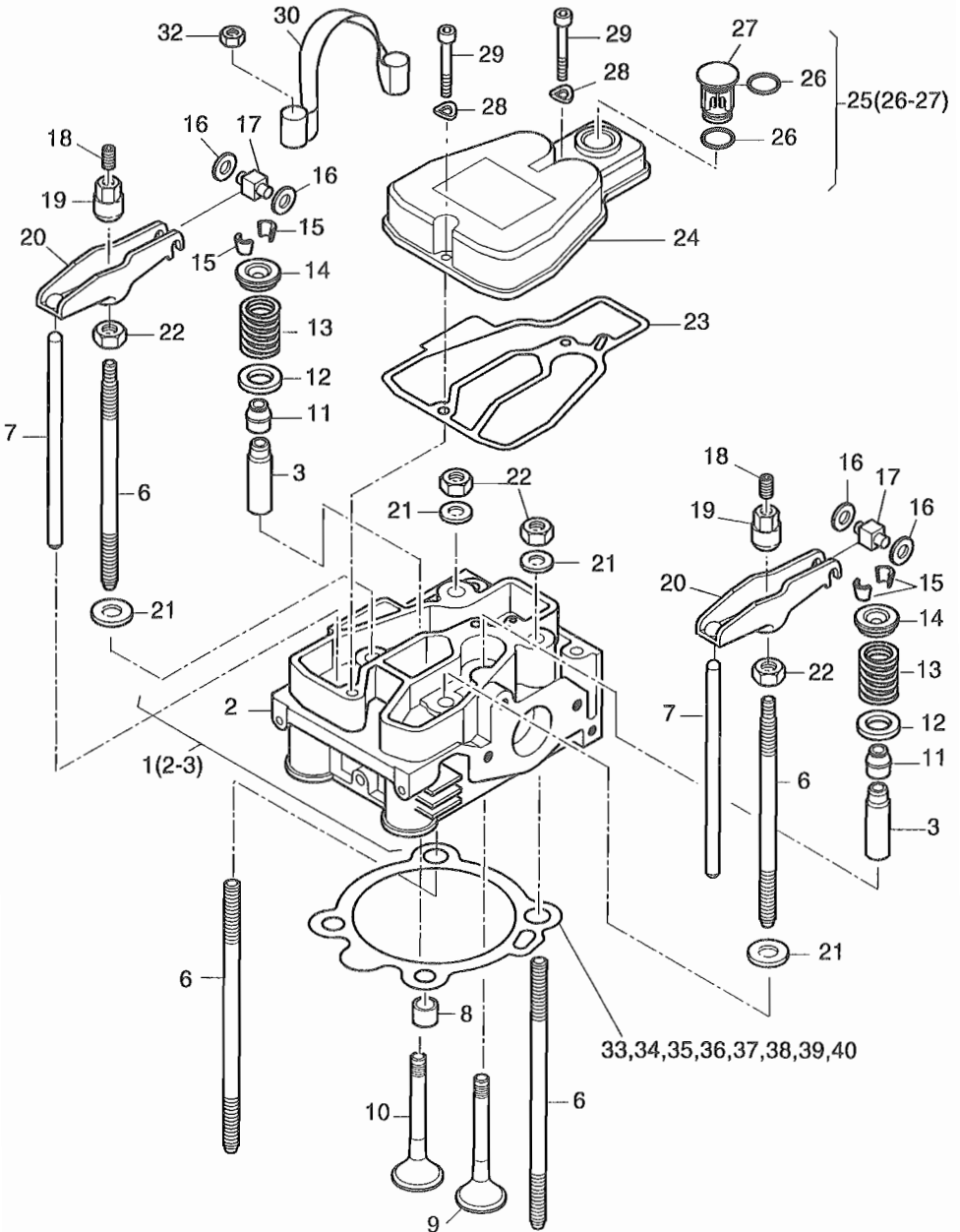

Fig.-No.	HATZ Ident-No.	Stück Qty.	P / W d / D	Bemerkungen Notes
		1B20V		
1	015 002 21	1		
2	-----	-		
3	051 194 00	2		
4	-----	-		
5	-----	-		
6	050 625 00	4		128 mm (M 8)
7	050 540 00	2		
8	041 075 00	2	d2	
9	050 532 00	1		
10	050 533 00	1		
11	504 258 00	2	d2	
12	040 937 00	2		
13	040 936 00	2		
14	040 938 00	2		
15	504 257 00	2		
16	504 451 00	4		6 x 12 x 1,2      DIN 988
17	050 911 01	2		
18	503 580 00	2	W2	M 8 x 10      DIN 913 - A3C Tuf.
19	050 547 00	2		
20	050 509 00	2		
21	050 612 01	4		8,1 x 20 x 3
22	503 643 00	4		M 8              DIN 934 - 10.9 A3C
23	050 557 00	1	d1, W4	
24	050 473 10	1		
25	015 096 00	1	P1	
26	504 259 00	2		16 x 2
27	-----	-		
28	500 812 00	2		A6              DIN 137 - A3C
29	503 749 00	2		M 6 x 35      DIN 912 - 8.8 A3C
30	041 176 00	1		
31	-----	-		
32	501 295 00	2		M 8              DIN 985 - A3C
33	050 594 00	0...1		0,3 mm
34	050 595 00	0...1		0,4 mm
35	050 596 00	0...1	d1	0,5 mm
36	050 597 00	0...1	d1	0,6 mm
37	050 598 00	0...1		0,7 mm
38	050 599 00	0...1		0,8 mm
39	050 600 00	0...1		0,9 mm
40	050 601 00	0...1		1,0 mm

M 10

Ölpumpe, Regler  
Oil pump, governor  
Pompe à huile, regulateur  
Bomba de aceite, regulador  
Pompa olio, regolatore

M 32

Drehzahlverstellung  
Speed control  
Réglage régime  
Ajuste de revoluc.  
Regolatore di giri

08

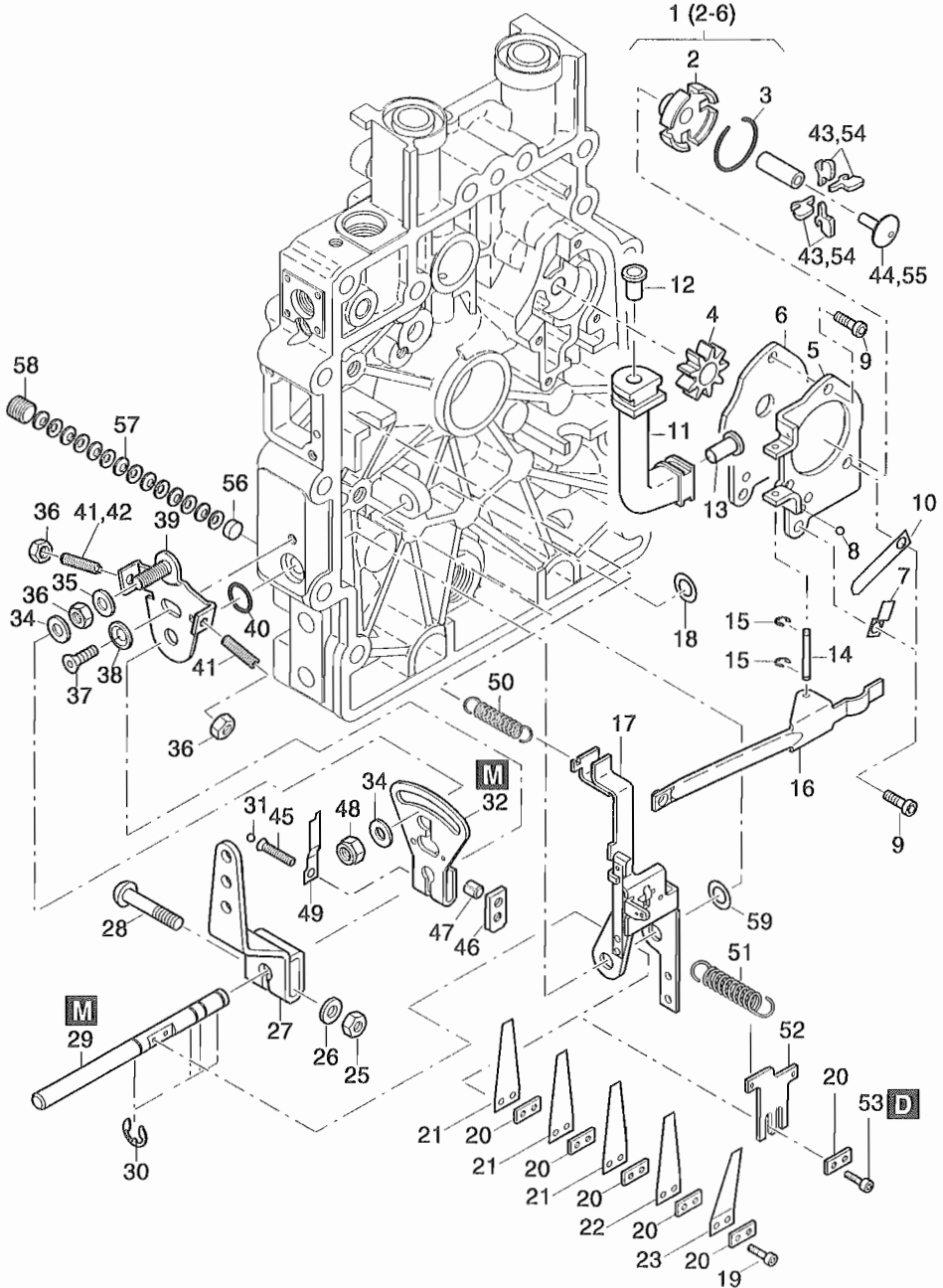

Fig.-No.	HATZ Ident-No.	Stück Qty.	P / W d / D	Bemerkungen Notes
1B20V				
1	015 302 10	1		
2	-----	-		
3	504 349 01	1		RB25      DIN 7993
4	-----	-		
5	-----	-		
6	-----	-		
7	050 971 00	1		
8	504 479 00	1		3,5 mm Kl. III
9	504 294 00	4		M 5 x 12    DIN 6912 - 8.8
10	050 973 00	1		0,4 mm
11	041 029 00	1		
12	504 474 00	1		A 8 x 0,5 x 12    DIN 7340 - St
13	504 475 00	1		A 10 x 0,75 x 12 DIN 7340 - St
14	050 786 00	1		
15	504 348 00	2		1,9            DIN 6799
16	050 794 00	1		
17	015 304 02	1		
18	501 258 00	1		8 x 14 x 0,5      DIN 988
19	504 350 00	2		M 3 x 12    DIN 912 - 8.8
20	050 798 00	1...5		
21	051 316 00	0...1		0,2 mm            } Gen.-PV 78
22	050 789 00	1...2		0,3 mm            } 951 385 00
23	051 486 00	1		0,4 mm    19° ∠    }
24	-----	-		
25	501 444 00	1		M 6            DIN 934 - 8 A3C
26	501 445 00	1		6,4            DIN 125 - St A3C
27	040 956 00	1		
28	039 273 00	1		M 6 x 32
29	050 793 01	1		
30	500 927 00	4		7            DIN 6799 A3C
31	503 471 00	1		∅ 3,175
32	013 330 00	1		
33	-----	-		
34	041 497 00	2		6 x 16 x 3
35	501 445 00	1		6,4            DIN 125-St A3C
36	501 444 00	3		M 6            DIN 934 - 8 A3C
37	504 239 00	1		M 6 x 20    DIN 7991-10.9 A3C
38	041 229 00	1		

**M 10**

Ölpumpe, Regler  
Oil pump, governor  
Pompe à huile, regulateur  
Bomba de aceite, regulador  
Pompa olio, regolatore

**M 32**

Drehzahlverstellung  
Speed control  
Réglage régime  
Ajuste de revoluc.  
Regolatore di giri

**08**

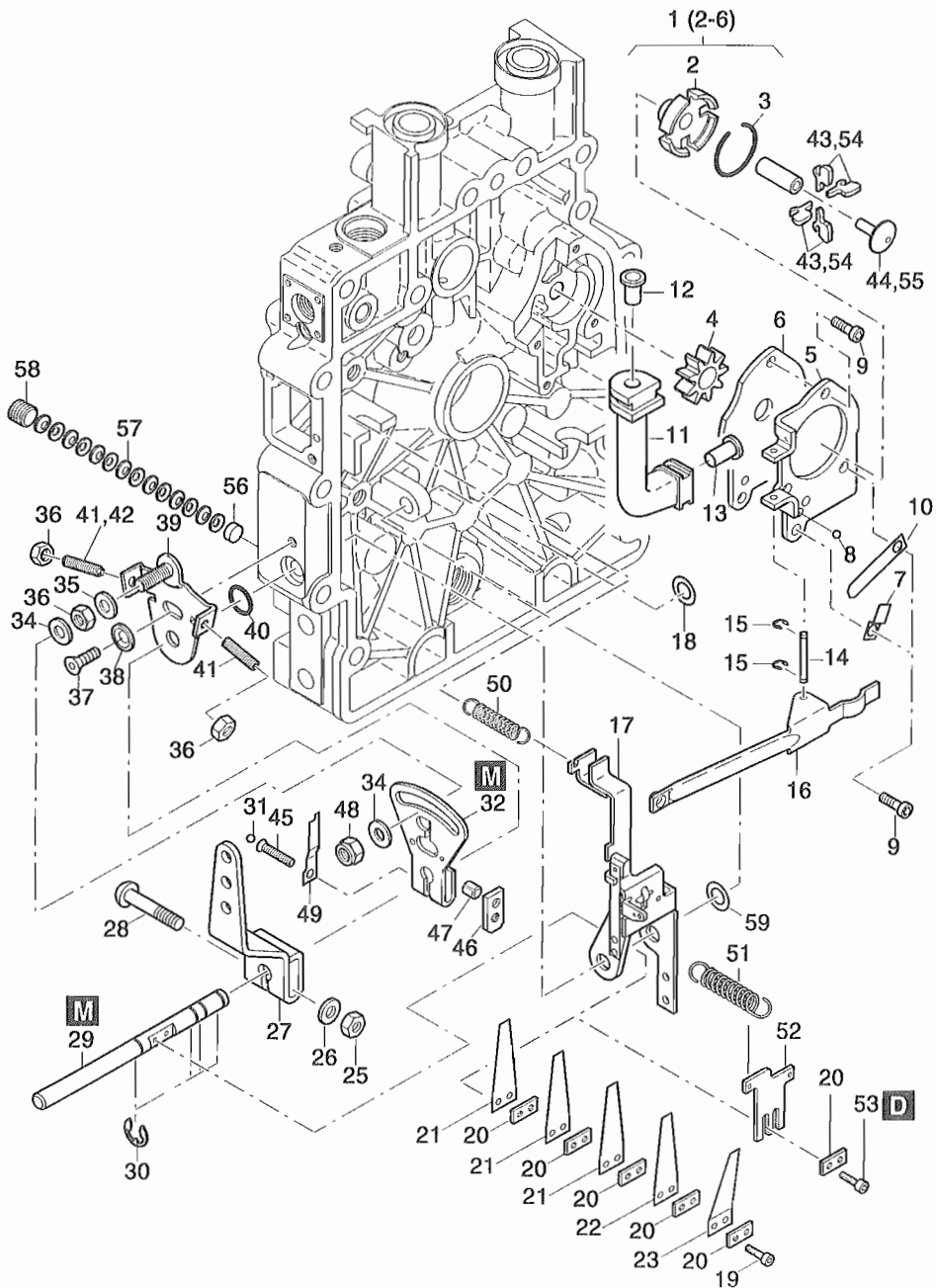

Fig.-No.	HATZ Ident-No.	Stück Qty.	P / W d / D	Bemerkungen Notes
1B20V				
39	013 164 02	1		
40	400 224 01	1		8 x 2 FPM 75 MOLYKOT.
41	501 381 00	1...2		M 6 x 35 DIN 915 - 45H
42	500 042 00	0...1		M 6 x 20 DIN 915 - 45H
43	050 796 01	8		
44	050 785 01	1		
45	504 753 00	1		M 5 x 25 ISO 7380-10.9 Zn
46	051 513 00	1		
47	504 754 00	1		5 x 8 DIN 7346
48	503 283 00	1		VM 6 DIN 980 - 8 A3C
49	041 228 00	1		
50	040 002 00	1		
51	051 309 00	1		
52	051 308 00	1		
53	504 653 00	2		M 3 x 8 DIN 912 - 8.8
54	051 469 00	4		Gen.-PV 78
55	051 470 01	1		Gen.-PV 78
56	051 517 00	1		8 x 3,2 x 0,5
57	504 758 00	14		
58	504 757 00	1		M 10 x 10 DIN 913 - A3C Tuf.
59	504 224 00	1		8 x 14 x 1,0 DIN 988

M 11

Steuerdeckel  
Timing cover  
Couvercle distribution  
Tapa de mando  
Coperchio distribuzione

09

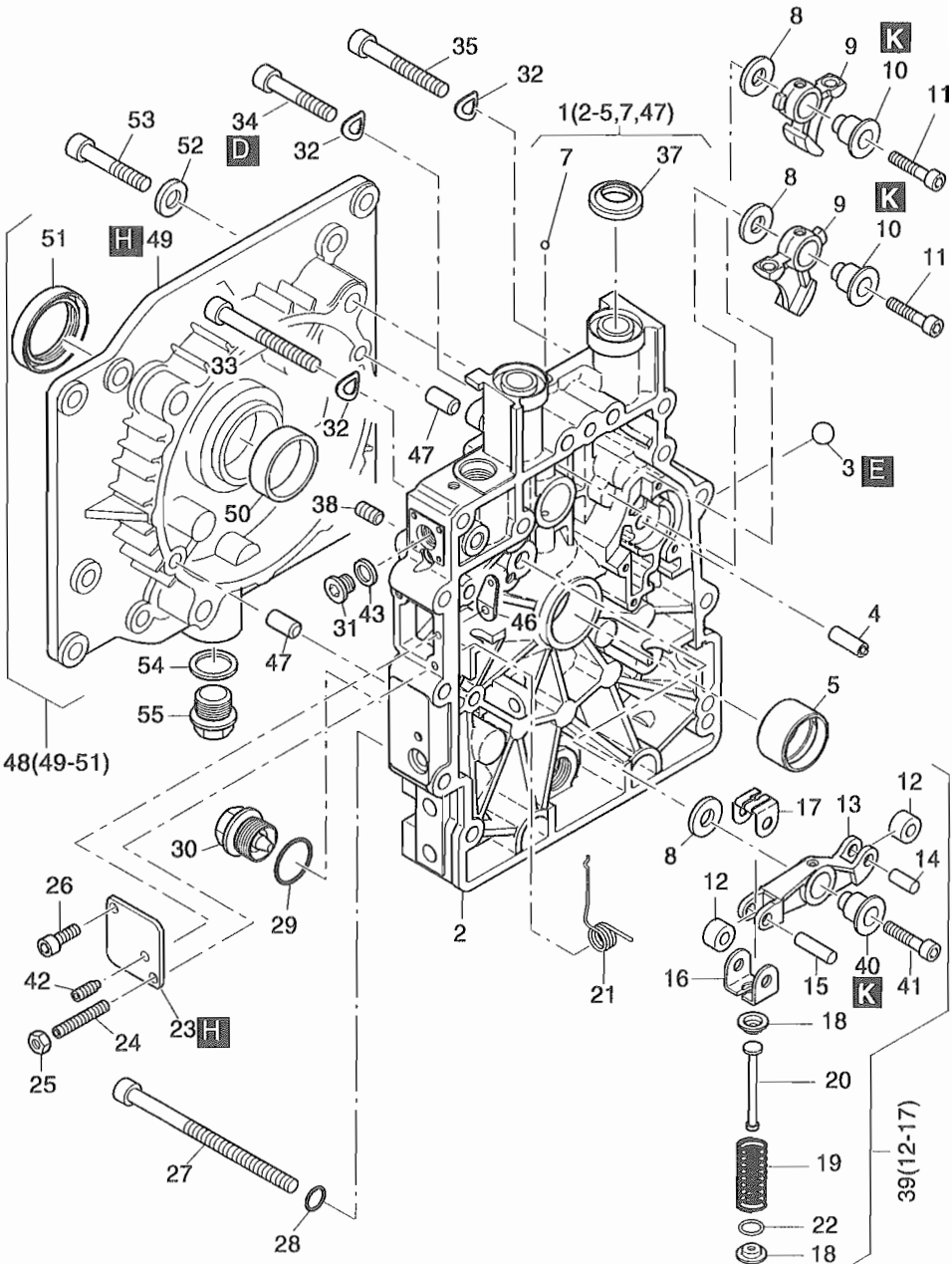



Fig.-No.	HATZ Ident-No.	Stück Qty.	P / W d / D	Bemerkungen Notes
1B20V				
1	013 401 00	1		
2	-----	-		
3	-----	-		
4	015 339 00	1		
5	050 531 00	1		
5	041 248 00	1		-0,5 mm
7	504 434 00	1		5,5 G20    DIN 5401
8	037 941 00	3		
9	050 534 00	2		
10	037 942 01	2		
11	504 579 00	2		M 6 x 25    DIN 912 - 10.9
12	-----	-		
13	-----	-		
14	-----	-		Pos. 39 (12 - 17)
15	-----	-		
16	-----	-		
17	-----	-		
18	040 948 02	2		
19	040 957 00	1		
20	040 947 00	1		
21	050 952 10	1		
22	041 339 00	1		10,7 x 16 x 0,5
23	040 952 10	1		
24	504 489 01	1		M 6 x 30    DIN 913 22 H A3C Tuf.
25	501 444 00	1		M 6          DIN 934 - 8 A3C
26	503 842 00	1		M 6 x 12    DIN 912 - 8 A3C Tuf.
27	504 261 00	2		M 8 x 120    DIN 912 - 8.8 A3C
28	501 629 00	2	D2	A 8 x 14    DIN 7603 - Cu
29	504 698 00	1	W4, D2	A 22 x 27    DIN 7603 - Vf
30	503 731 00	1	W1	AM 22 x 1,5 MAGN.
31	504 592 00	1		M 12 x 1,5 x 16 DIN 908-St. A3C
32	500 951 00	13		A 8          DIN 137 A3C
33	502 488 00	1		M 8 x 60    DIN 912 - 8.8 A3C
34	504 534 00	2		M 8 x 45    DIN 912 - 8.8 A3C Tuf.
35	503 929 00	10		M 8 x 50    DIN 912 - 8.8 A3C
37	041 065 00	2	d2	
38	503 580 00	5		M 8 x 10    DIN 913 - A3C Tuf.
39	013 196 01	1		
40	040 968 10	1		

M 11

Steuerdeckel  
Timing cover  
Couvercle distribution  
Tapa de mando  
Coperchio distribuzione

Tafel Nr.  
Tabl. No.  
Tavola N.

09

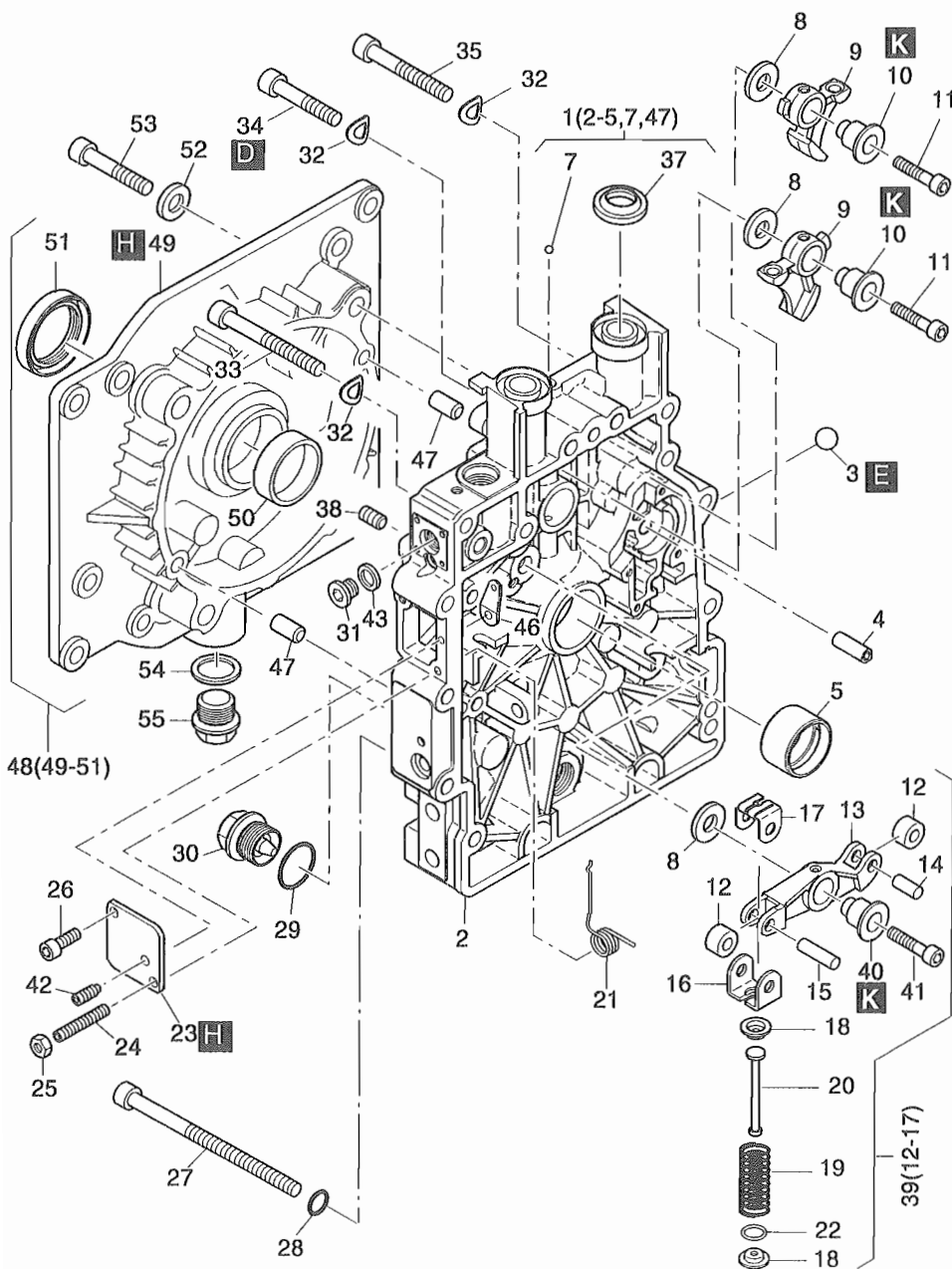

Fig.-No.	HATZ Ident-No.	Stück Qty.	P / W d / D	Bemerkungen Notes
1B20V				
41	504 699 00	1		M 6 x 30 DIN 912 - 10.9
42	502 749 01	1		M 4 x 20 DIN 915 - Tuf. 360 G
43	041 220 00	1		12 x 14,6
46	051 271 00	1		
47	502 491 01	2		8 m 6 x 20 DIN 6325
48	016 267 00	1		
49	-----	-		
50	501 934 00	1		
51	400 337 00	1		30 x 47 x 8
52	500 170 00	4		10,5 DIN 433 - St A3C
53	504 755 00	4		M 10 x 45 DIN 6912 - 8.8 A3C
54	500 014 00	1		A 18 x 22 DIN 7603 - Cu
55	500 442 00	1		M 18 x 1,5 DIN 910

**M 13**

Gebälse  
Blower  
Soufflerie  
Ventilador  
Ventilatore

**M 17**

Schwungrad  
Flywheel  
Volant  
Volante  
Volano

**10**

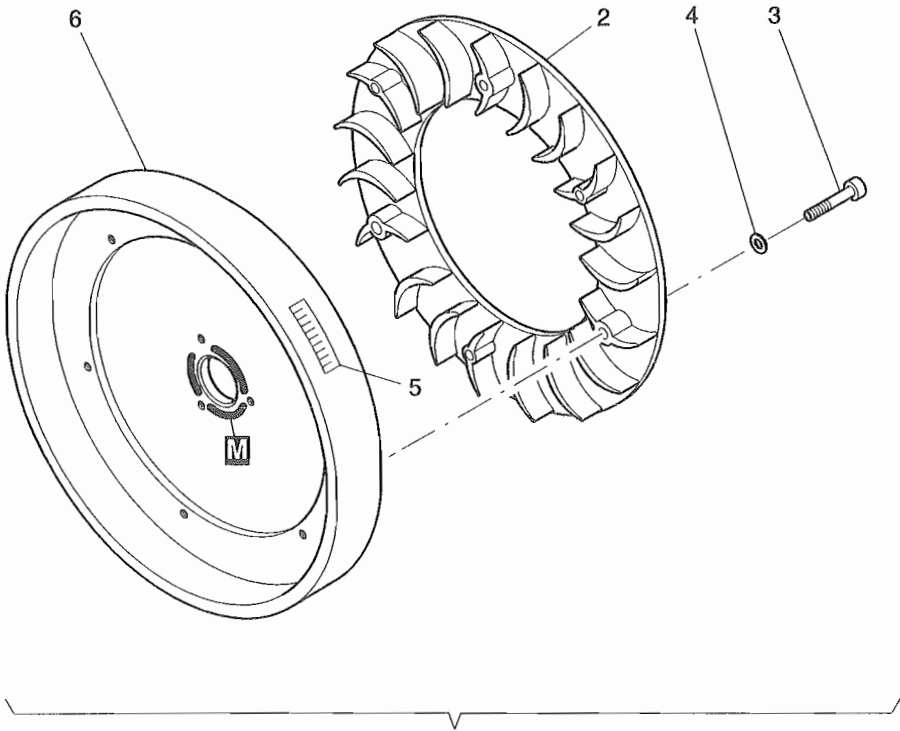

1(2 - 6)

Fig.-No.	HATZ Ident-No.	Stück Qty.	P / W d / D	Bemerkungen Notes
1B20V				
1	015 797 10	1		
2	013 213 10	1		
3	503 273 00	6		M 4 x 20 DIN 912 - 8.8 A3C
4	500 034 00	6		A 4 DIN 137
5	041 173 00	1		„Handstart“ OT
6	050 522 20	1		

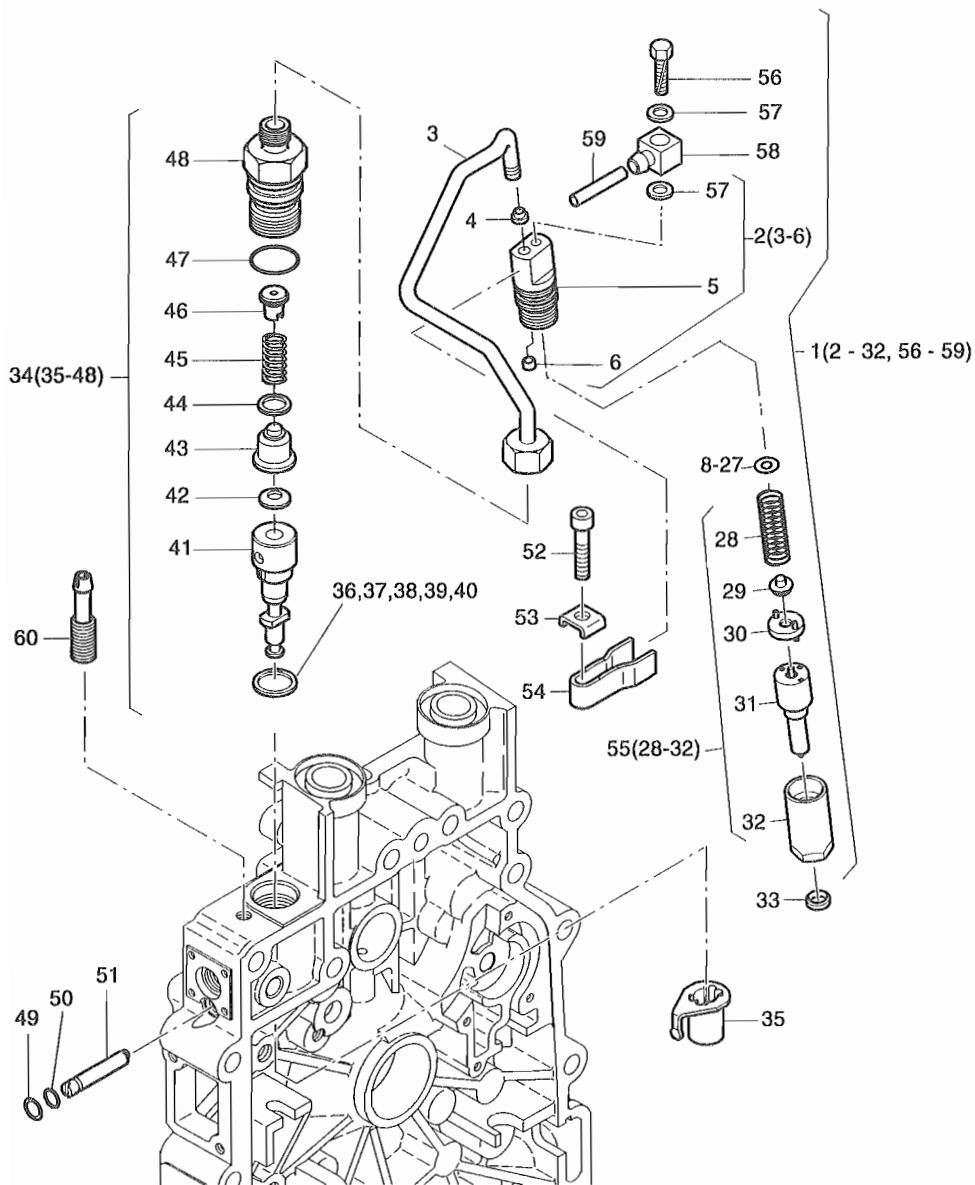

Fig.-No.	HATZ Ident.-No.	Stück Qty.	P / W d / D	Bemerkungen Notes
1B20V				
1	016 216 00	1		
2	015 771 10	1		
3	-----	-		
4	050 961 01	0...1		4,9 mm
4	050 706 01	0...1		5,3 mm
5	-----	-		
6	050 815 00	1		
7	-----	-		
8	504 364 00	0...1		1,00 mm
9	504 365 00	0...1		1,04 mm
10	504 366 00	0...1		1,10 mm
11	504 367 00	0...1		1,14 mm
12	504 368 00	0...1		1,20 mm
13	504 369 00	0...1		1,24 mm
14	504 370 00	0...1		1,30 mm
15	504 371 00	0...1		1,34 mm
16	504 372 00	0...1		1,40 mm
17	504 373 00	0...1		1,44 mm
18	504 374 00	0...1		1,50 mm
19	504 375 00	0...1		1,54 mm
20	504 376 00	0...1		1,60 mm
21	504 377 00	0...1		1,64 mm
22	504 378 00	0...1		1,70 mm
23	504 379 00	0...1		1,74 mm
24	504 380 00	0...1		1,80 mm
25	504 381 00	0...1		1,84 mm
26	504 382 00	0...1		1,90 mm
27	504 383 00	0...1		1,94 mm
28	-----	-		
29	-----	-		
30	-----	-		
31	504 422 00	1	P1	
32	-----	-		
33	050 705 00	1		
34	013 222 00	1		
35	013 308 01	1		
36	040 963 00	0...1		0,2 mm
37	040 964 00	0...1		0,3 mm
38	040 965 00	0...1		0,4 mm

s. 951 258 01

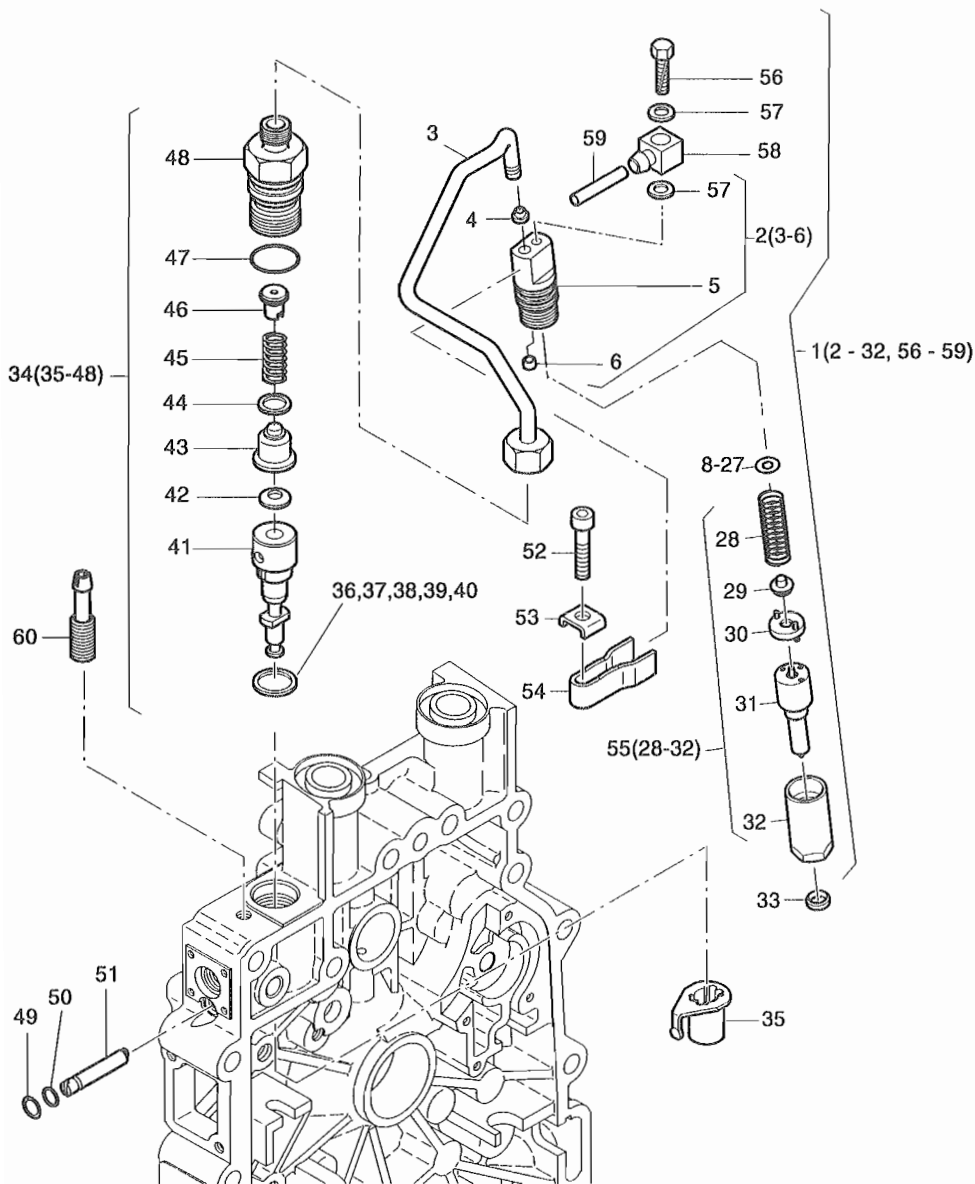



Fig.-No.	HATZ Ident-No.	Stück Qty.	P / W d / D	Bemerkungen Notes
1B20V				
39	040 966 00	0...1		0,5 mm
40	040 967 00	0...1		0,6 mm
41	-----	-		
42	504 716 00	1		8            DIN 6796
43	-----	-		
44	504 769 00	1		9,5 x 13 x 0,5
45	-----	-		
46	-----	-		
47	504 892 00	1		17 x 2
48	504 459 00	1		
49	504 760 00	1		8            DIN 470 Al
50	504 339 00	1		3,3 x 1,0
51	040 977 00	1		
52	503 239 00	1		M 6 x 30    DIN 912 - 8.8 A3C
53	050 893 00	1		6,4
54	050 567 00	1		
55	013 261 00	1		
56	504 645 00	1		AM 4 x 16    DIN 7315 St. Zn
57	501 108 00	2		A 4 x 8      DIN 7603 - Cu
58	051 290 00	1		
59	051 303 00	1		2,5 x 295
60	050 842 01	1		

Reversierstarter  
Recoil starter  
Demarreur reversible  
Arrancador reversible  
Avviamento a strappo

M 15

12

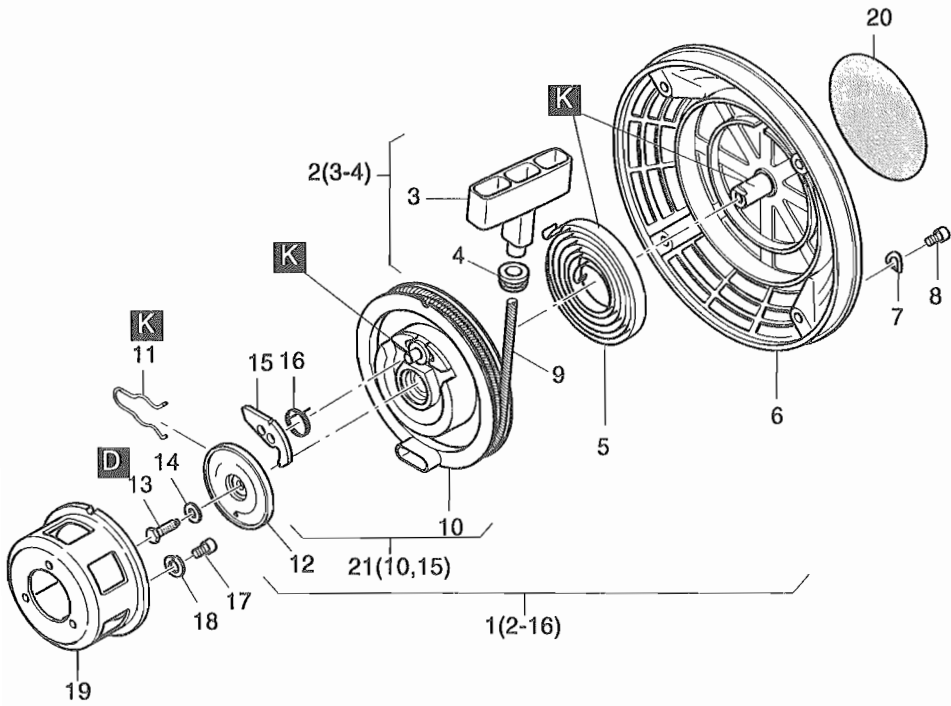

Fig.-No.	HATZ Ident-No.	Stück Qty.	P / W d / D	Bemerkungen Notes
		1B20V		
1	015 150 02	1		
2	014 978 00	1		
3	-----	-		
4	036 652 00	1		
5	050 452 01	1		
6	015 693 00	1		
7	500 812 00	4		A 6      DIN 137
8	500 627 00	4		M 6 x 10    DIN 912 - 8.8
9	050 889 01	1		1750 mm
10	-----	-		
11	050 449 01	1		
12	050 450 01	1		
13	501 463 00	1		M 6 x 18    DIN 933 - 8.8 A3C
14	501 656 00	1		6,5 x 14    DIN 6904 - A3C
15	050 448 00	1		
16	050 613 00	1		
17	500 627 00	3		M 6 x 10    DIN 912 - 8.8
18	501 709 00	3		6            DIN 128 - A3C
19	504 458 00	1		
20	051 091 00	1		
21	015 488 00	1		

Luftführung - 1B20  
 Air duction - 1B20  
 Carter ventilation - 1B20  
 Conducción de aire - 1B20  
 Carter ventilatore - 1B20

**M 26**

**13**

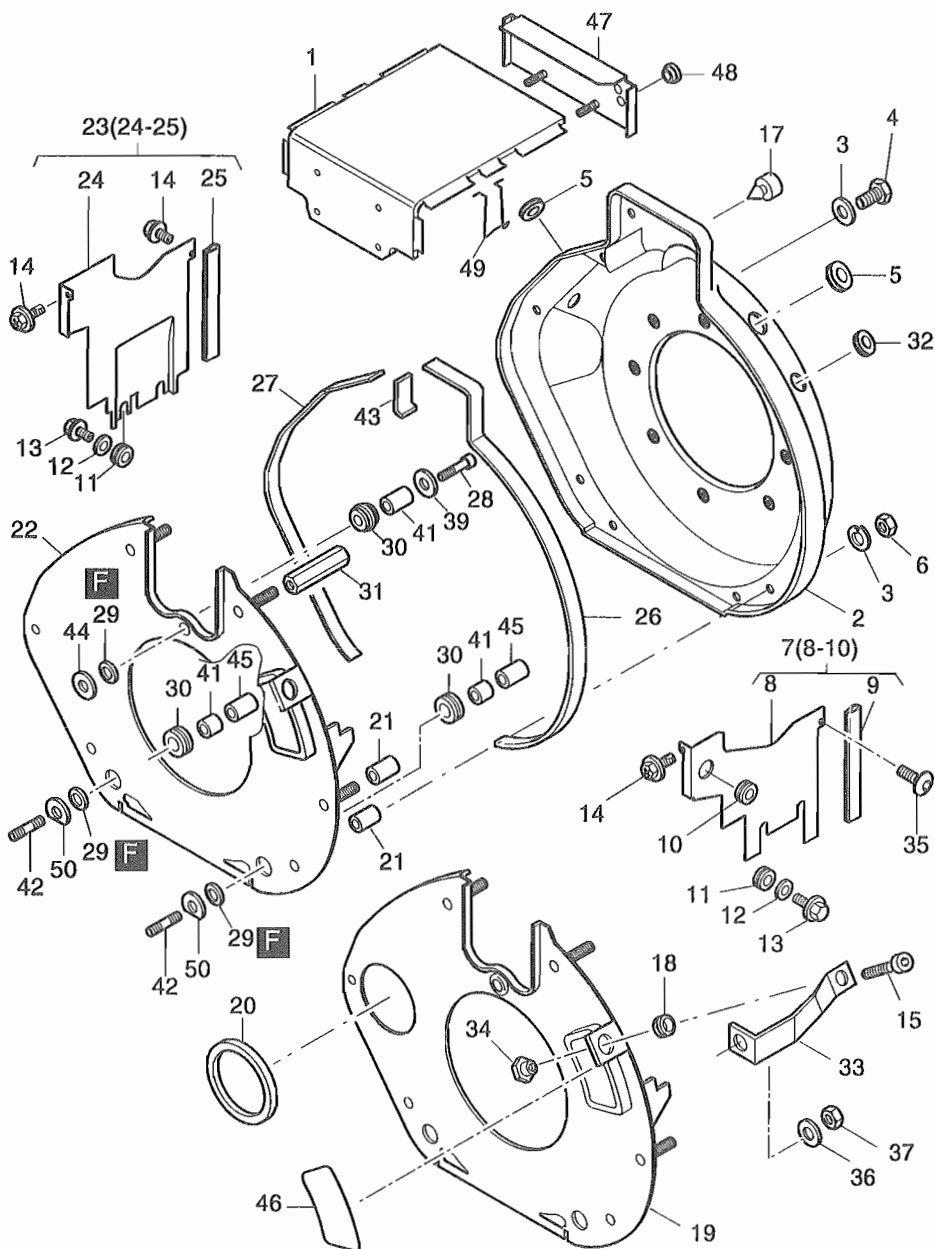

Fig.-No.	HATZ Ident-No.	Stück Qty.	P / W d / D	Bemerkungen Notes
1B20V				
1	015 335 04	1		
2	013 168 00	1		
3	501 709 00	7		6          DIN 128 - A3C
4	501 463 00	1		M 6 x 18    DIN 933 - 8.8 A3C
5	504 617 00	2		
6	501 444 00	6		M 6          DIN 934 - 8 A3C
7	013 166 00	1		
8	-----	-		
9	040 976 00	1		107 mm
10	503 348 00	1		
11	501 638 01	4		
12	504 416 00	3		4,3          DIN 9021 - A3C 140HV
13	504 454 00	3		M 4 x 10 St 8.8 A3A DIN 7500
14	503 356 00	3		M 6 x 16 KZ1 8.8 A3D
15	501 707 00	1		M 6 x 16    DIN 912 - 8.8 A3C
16	-----	-		
17	503 926 10	2		
18	503 928 00	1		
19	016 070 00	1		E-Start
20	040 995 00	1		
21	041 390 00	5		6,5 x 12 x 18
22	016 071 00	1		
23	013 165 00	1		
24	-----	-		
25	040 976 00	1		107 mm
26	041 245 00	1		470 mm
27	041 246 00	1		388 mm
28	501 708 00	1		M 6 x 25    DIN 912 - 8.8 A3C
29	035 755 00	3		
30	009 214 00	3		
31	041 244 00	1		57 mm
32	504 533 00	1		
33	015 995 00	1		
34	041 232 00	1		M 6
35	503 280 00	1		AM 6 x 16 17065 - 8.8
36	500 951 00	1		A 8          DIN 137 A3C

**M 26**

Luftführung - 1B20  
Air duction - 1B20  
Carter ventilation - 1B20  
Conducción de aire - 1B20  
Carter ventilatore - 1B20

Tafel Nr.  
Tabl. No.  
Tavola N.

**13**

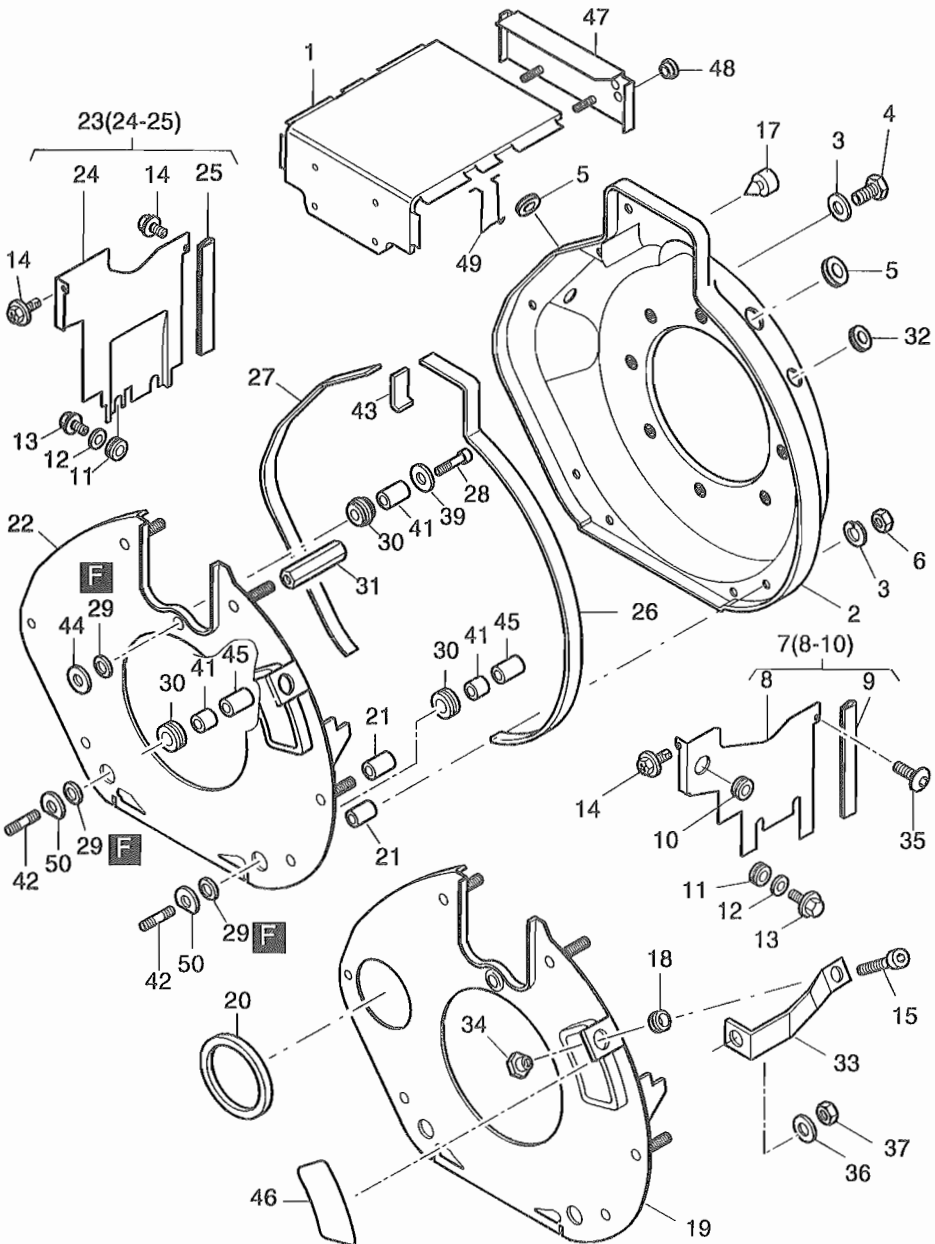

Fig.-No.	HATZ Ident-No.	Stück Qty.	P / W d / D	Bemerkungen Notes
		1B20V		
37	503 447 00	1	M 8	DIN 936 - 5 A3C
38	-----			
39	501 709 00	1	6	DIN 128 A3C
40	-----			
41	041 191 00	3	6 x 8 x 14	
42	504 581 00	2	M 6 x 45	DIN 835 - 8.8 A3C
43	050 073 00	1	48 mm	
44	040 420 00	1	6,5 x 22,5 x 1	
45	041 390 00	2	6,5 x 12 x 18	
46	041 138 00	1		
47	015 793 00	1		
48	503 348 00	2		
49	051 441 00	1		
50	041 453 00	2		

Kurbelgehäusentlüftung  
Crankcase breathing system  
Reniflard  
Purgador  
Sfiato basamento

M 31

14

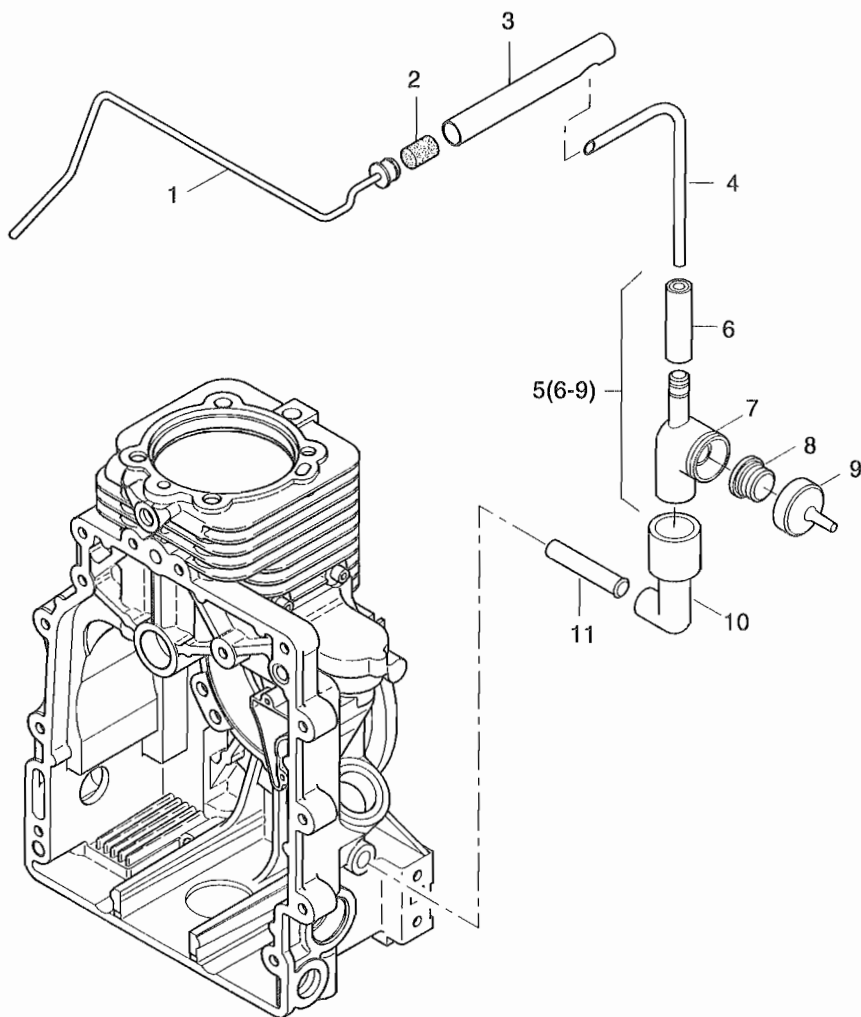



Fig.-No.	HATZ Ident-No.	Stück Qty.	P / W d / D	Bemerkungen Notes
		1B20V		
1	013 391 00	1		
2	051 029 00	1		Filter, Filtre, Filtro
3	041 396 00	1		
4	041 397 00	1		
5	013 396 00	1		
6	013 390 00	1		
7	-----	-		
8	035 687 00	1		
9	035 686 00	1		
10	041 361 00	1		
11	-----	-		

Kraftstoffbehälter  
 Fuel tank  
 Reservoir à carburant  
 Depósito combustible  
 Serbatoio

A 01

15

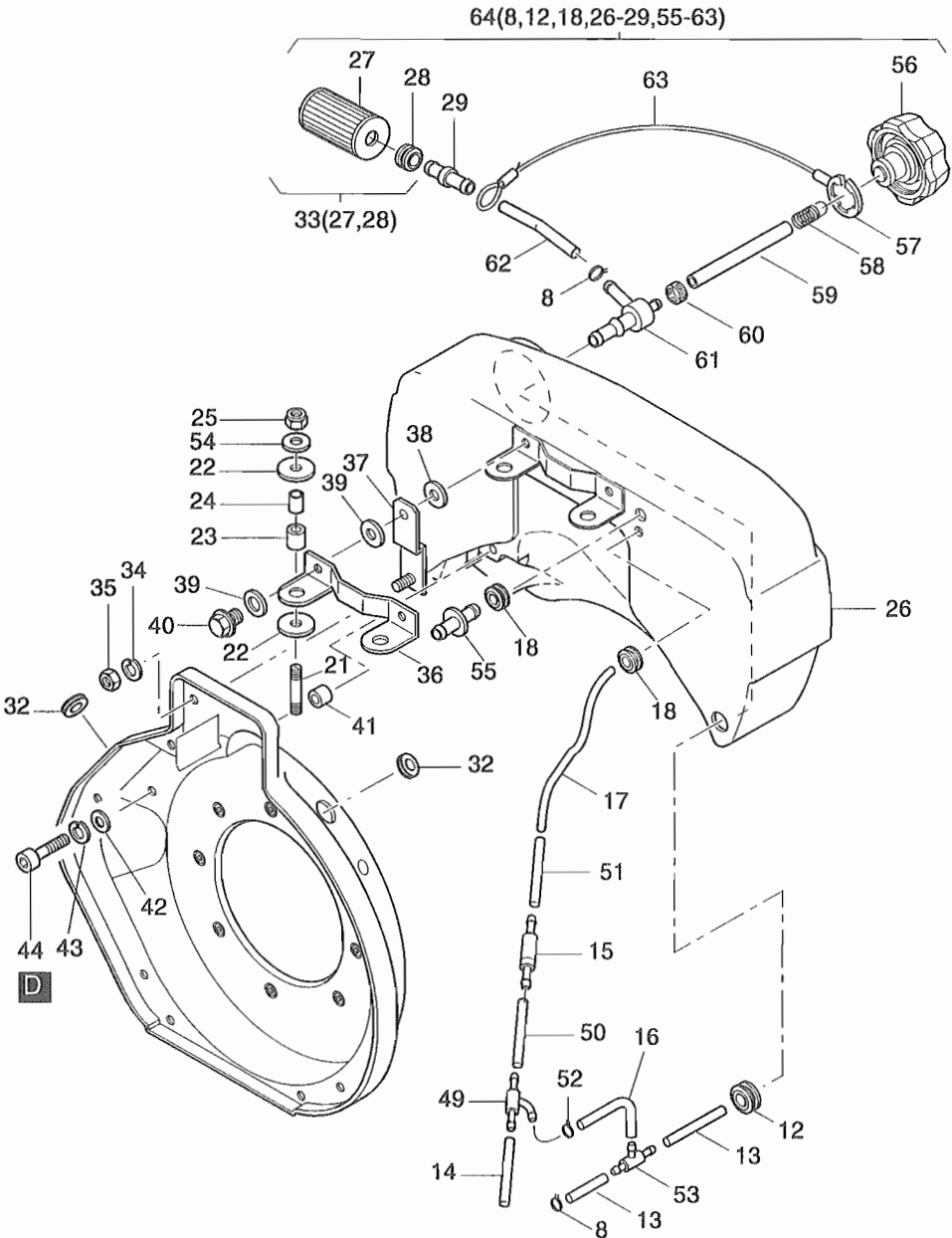

Fig.-No.	HATZ Ident-No.	Stück Qty.	P / W d / D	Bemerkungen Notes
1B20V				
8	504 411 00	2	P1	11,8 - 505 R
12	504 408 00	1		
13	051 231 00	2		7 x 70
14	050 853 00	1		3,5 x 45
15	015 346 00	1		
16	036 733 00	1		4,5 x 170
17	051 576 00	1		
18	051 304 00	2		
21	502 319 00	2		M 8 x 25    DIN 835 - 8.8 A3C
22	051 098 10	4		8,2 x 22 x 2
23	050 868 10	2		
24	051 228 00	2		
25	400 284 00	2		VM 8        DIN 980 - 8 C3A
26	-----	-		
27	-----	-		
28	-----	-		
29	050 844 00	1		
32	051 077 00	2		
33	016 352 00	1	W2	
34	501 709 00	2		6            DIN 128 A3C
35	501 444 00	2		M 6         DIN 934 - 8 A3C
36	051 085 11	1		
37	013 313 00	2		
38	501 200 00	2		A 6,4        DIN 9021 St A3C
39	051 100 10	4		7,1 x 17,9 x 2
40	015 570 00	2		6 x 18
41	041 188 00	2		6,5 x 13 x 4,8
42	501 445 00	2		6,4         DIN 125 St A3C
43	501 709 00	2		6            DIN 128 A3C
44	501 707 00	2		M 6 x 16    DIN 912 - 8.8 A3C
49	051 227 01	1		
50	051 232 00	1		3,5 x 40
51	036 643 00	1		4,5 x 75
52	503 998 01	1		11,3
53	504 596 00	1		
54	501 481 00	2		8,4         DIN 125 St A3C



Fig.-No.	HATZ Ident-No.	Stück Qty.	P / W d / D	Bemerkungen Notes
1B20V				
55	051 296 10	1		
56	016 203 00	1		
57	504 800 00	1		20 x 1      DIN 984
58	504 792 00	1		
59	051 601 00	1		2,5 x 165
60	504 801 00	1		
61	016 239 00	1		
62	050 849 00	1		7 x 190
63	016 289 00	1		≈ 320 mm
64	016 242 00	1		3 l

# A 02

Luftfilter  
Air filter  
Filtre à air  
Filtro de aire  
Filtro aria

16

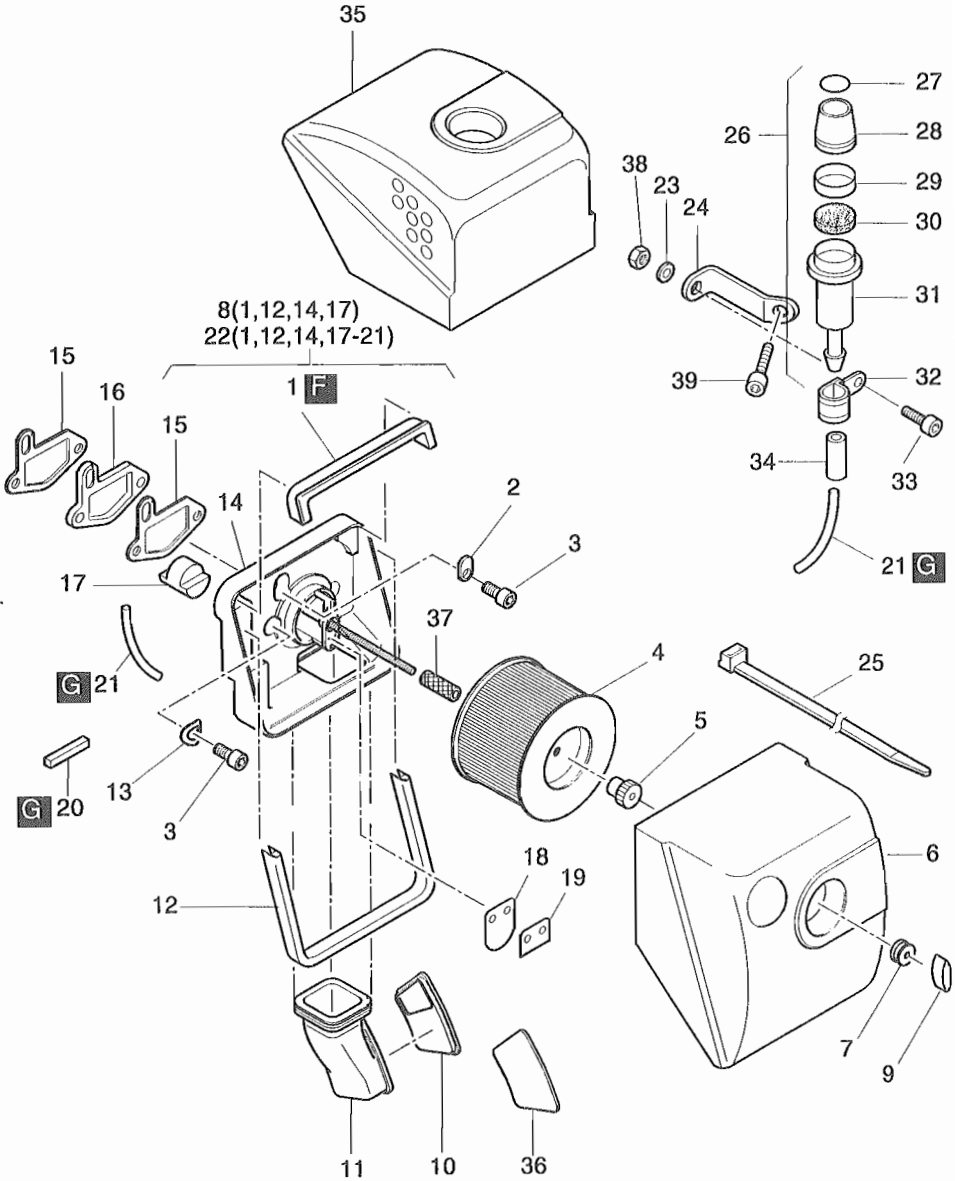

Fig.-No.	HATZ Ident-No.	Stück Qty.	P / W d / D	Bemerkungen Notes
1B20V				
1	050 829 00	1		
2	050 564 00	1		
3	501 715 00	3		M 8 x 25    DIN 912 - 8.8 A3C
4	504 260 00	1	W2	
5	504 543 00	1		
6	050 549 00	1		
7	504 358 00	1		
8	016 293 00	1		
9	504 522 00	1		
10	041 042 00	1		
11	041 030 00	1		
12	040 563 01	1		347 mm
13	500 951 00	2		
14	-----	-		
15	050 563 00	2	d2	
16	050 883 00	1		
17	050 981 00	1		
18	051 471 00	1		(schwarz, black, noir)
19	051 472 00	1		(rot, red, rouge)
20	051 750 00	1		14 x 9 x 30
21	050 446 10	1		2 x 4 x 135
22	016 302 00	1		f. Pos. 26
23	501 709 00	1		6            DIN 128 - A3C
24	051 646 00	1		
25	503 584 00	1		
26	014 998 01	1		(Pos. 27-31)
27	050 445 01	1		
28	050 436 01	1		
29	050 456 00	1		(grün, green, vert, verde)
30	051 372 00	1		Filter, Filtre, Filtro
31	050 437 00	1		
32	501 735 00	1		10/15
33	501 707 00	1		M 6 x 16    DIN 912 - 8.8 A3C
34	039 177 00	1		3,5 x 140
35	051 319 00	1		
36	041 138 00	1		
37	051 662 00	1		32 mm
38	501 444 00	1		M 6            DIN 934 - 8 A3C
39	501 706 00	1		M 6 x 20    DIN 912 - 8.8 A3C

Abgasdämpfer - 1B20  
 Exhaust silencer - 1B20  
 Silencieux - 1B20  
 Silenciador - 1B20  
 Marmitta - 1B20

A 03

17

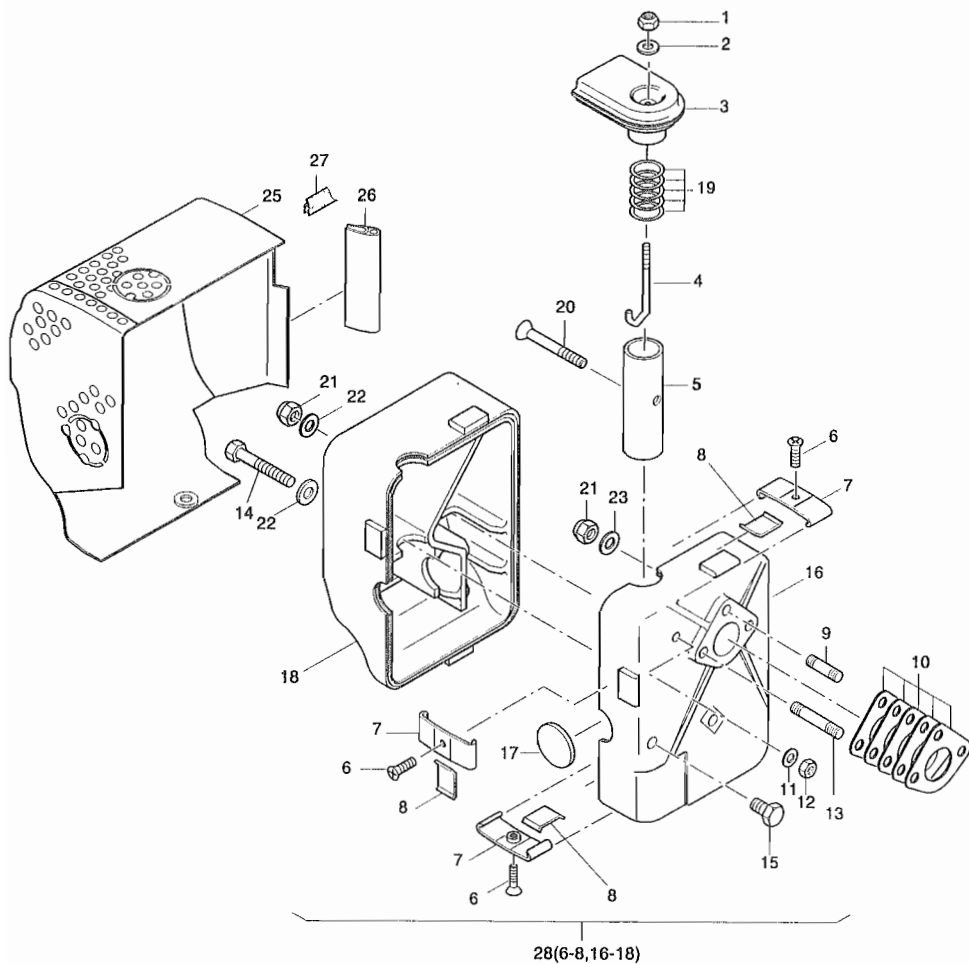



Fig.-No.	HATZ Ident-No.	Stück Qty.	P / W d / D	Bemerkungen Notes
1B20V				
1	400 283 00	1		M6 SSN 440 - 8 - C3P
2	501 445 00	1		6,4 DIN 125 - St A3C
3	015 313 11	1		
4	050 811 01	1		M6
5	050 814 10	1		
6	504 225 00	3		M 6 x 12 DIN 7991 - 8.8 A3C
7	015 312 01	3		
8	050 816 11	3		
9	501 281 00	2		M 8 x 30 DIN 835 - 10.9 A3C
10	050 801 00	5	d5	
11	501 445 00	1		6,4 DIN 125 - St A3C
12	400 283 00	1		M 6 SSN 440-8 C3P
13	500 395 00	1		M 8 x 110 DIN 835 - 8.8 A3C
14	500 288 00	1		M 8 x 90 DIN 931 - 8.8 A3C
15	504 505 00	1		M 8 x 12
16	-----			
17	050 810 02	1		
18	-----			
19	051 270 00	5		28,1 x 34 x 0,5
20	504 450 00	1		M 6 x 35 DIN 7881 - 8.8 A3C
21	400 284 00	3		DIN 980-8 C3A
22	501 481 00	2		8,4 DIN 125-St. A3C
23	501 230 00	2		8.4 DIN 7349
24	-----	-		
25	015 323 00	1		
26	051 003 00	1		65 mm
27	051 350 00	1		33 mm
28	015 311 05	1		(Pos. 6 - 8, 16 - 18)

**A 05**

Starter, Generator  
Starter, alternator  
Démarrreur, alternateur  
Arrancador, alternador  
Motorino avviamento, alternatore

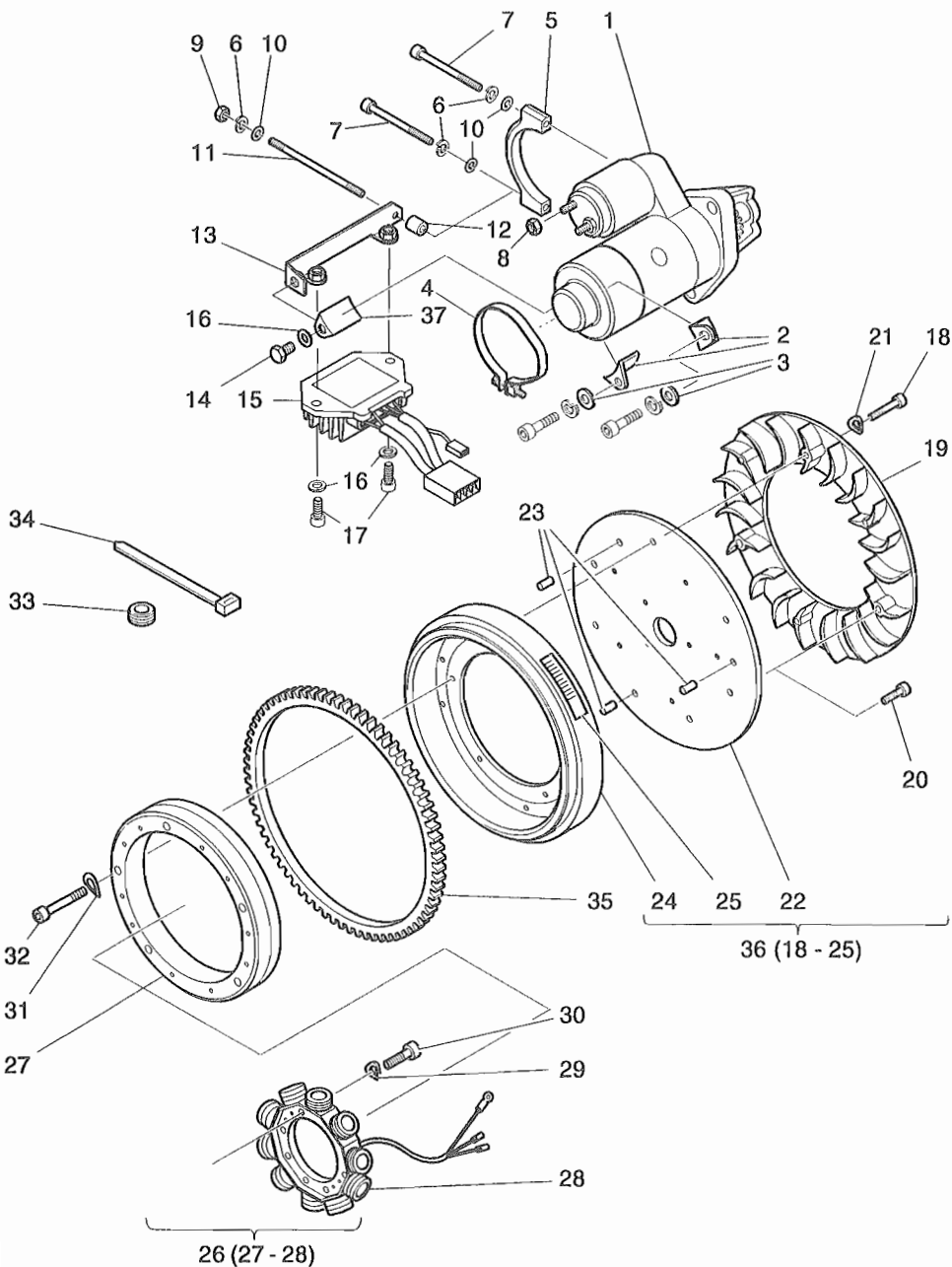

Fig.-No.	HATZ Ident-No.	Stück Qty.	P / W d / D	Bemerkungen Notes
1B20V				
1	504 262 01	1		12 V
2	041 384 00	2		
3	501 481 00	2		8,4          DIN 125 - St A3C
4	041 156 00	1		
5	040 991 00	1		
6	501 709 00	2		6          DIN 128 - A3C
7	504 443 00	2		M 6 x 80    DIN 912 - 8.8 A3C
8	500 232 00	1		BM8        DIN 439 - 5 A3C
9	501 444 00	1		M 6         DIN 934 - 8 A3C
10	501 445 00	2		6,4         DIN 125 - St A3C
11	504 559 00	1		MFS 6 x 90 DIN 949 - 1 8.8 A3C
12	036 714 00	1		7 x 12 x 15
13	015 609 00	1		
14	500 962 00	1		M 8 x 12    DIN 933 - 8.8 A3C
15	051 007 01	1		12 V
16	501 481 00	3		8,4          DIN 125 - St A3C
17	501 654 00	2		M 8 x 16    DIN 912 - 8.8 A3C
18	503 273 00	6		M 4 x 20    DIN 912 - 8.8 A3C
19	013 213 10	1		
20	504 168 00	3		M 6 x 16    DIN 912 - 8.8 A3C Tuf.
21	500 034 00	6		A 4          DIN 137 - St
22	040 987 20	1		
23	500 352 00	3		6 x 12        DIN 1481 55 Si 7
24	040 982 10	1		
25	041 172 00	1		„E-Start“ OT
26	504 359 01	1		12 V
27	-----	-		
28	-----	-		
29	500 819 00	4		A 5          DIN 137 A3C
30	504 271 00	4		M 5 x 25    DIN 912 - 8.8 A3C
31	500 812 00	5		A 6          DIN 137 A3C
32	504 487 00	5		M 6 x 30    DIN 6912 - 8.8 A3C
33	035 654 00	1		
34	503 584 00	3		
35	040 986 00	1		
36	015 798 10	1		
37	041 384 00	1		

A 05  
A 10

Armaturen, Leitungen  
Electric equipment, wirings  
Équipement électrique, cable  
Equipo eléctrico, cables  
Equipaggiamento elettrico, cablaggio

Tafel Nr.  
Tabl. No.  
Tavola N.

19

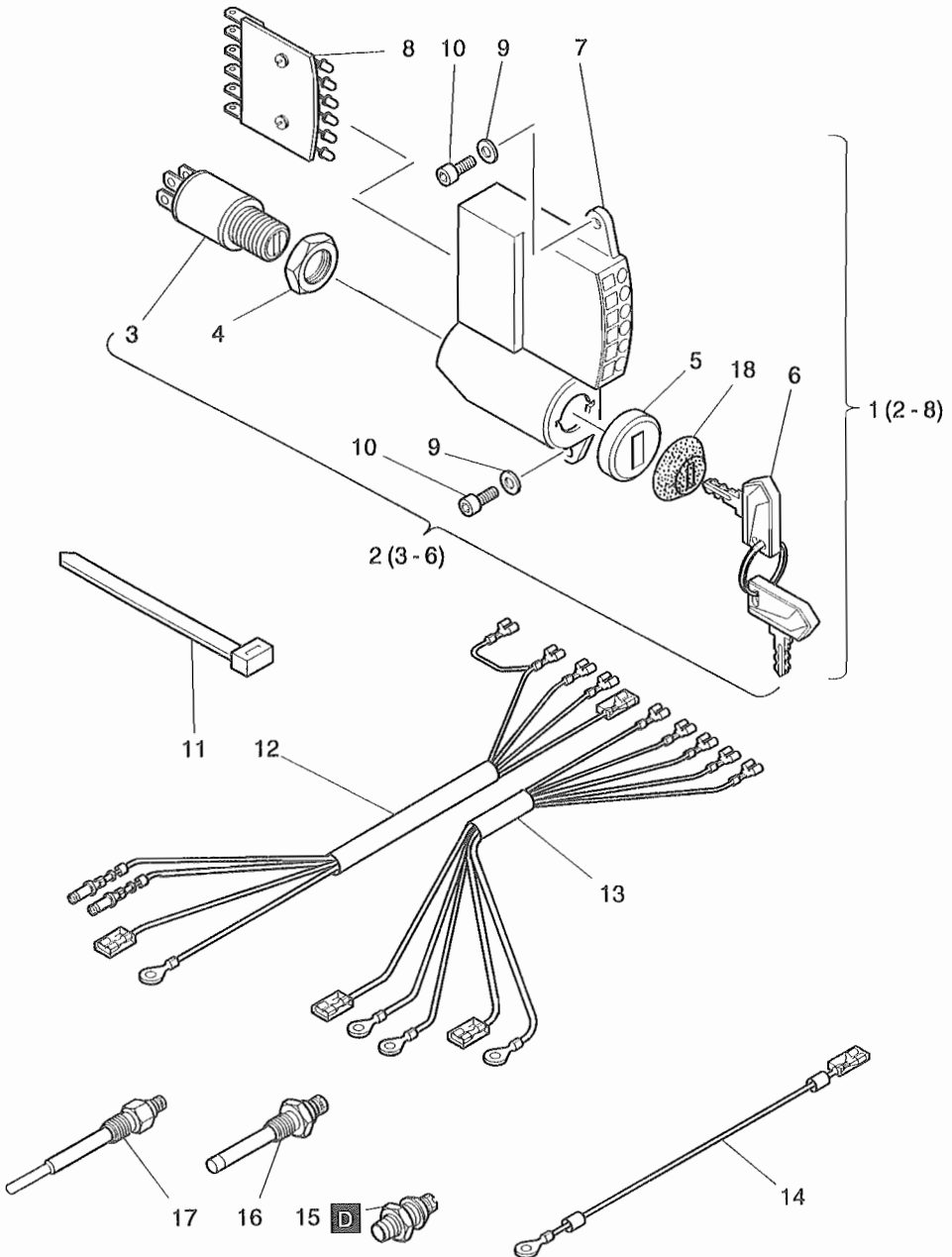

Fig.-No.	HATZ Ident-No.	Stück Qty.	P / W d / D	Bemerkungen Notes
		1B20V		
1	015 608 01	1		
2	503 844 01	1		
3	-----	-		
4	-----	-		
5	-----	-		
6	504 049 00	1		14644
7	051 010 00	1		
8	050 921 00	1		
9	501 445 00	2		6,4      DIN 125 St A3C
10	501 491 00	2		M 6 x 12    DIN 912 - 8.8 A3C
11	503 584 00	2		
12	015 421 01	1		
13	-----	-		
14	015 468 00	1		
15	400 213 00	1		Oil
16	502 686 00	1		Temp.
17	504 492 00	1		12 V
18	051 264 02	1		

**Serien-Nr.-Änderungen**  
**Serial-code modification list**  
**Modification des Nos de serien**  
**Modificación de los Nos de serie**  
**Modifica dei codici**

**IMT-No.**

---

1 B 20 V.10

1 B 20 V.11

98.580