

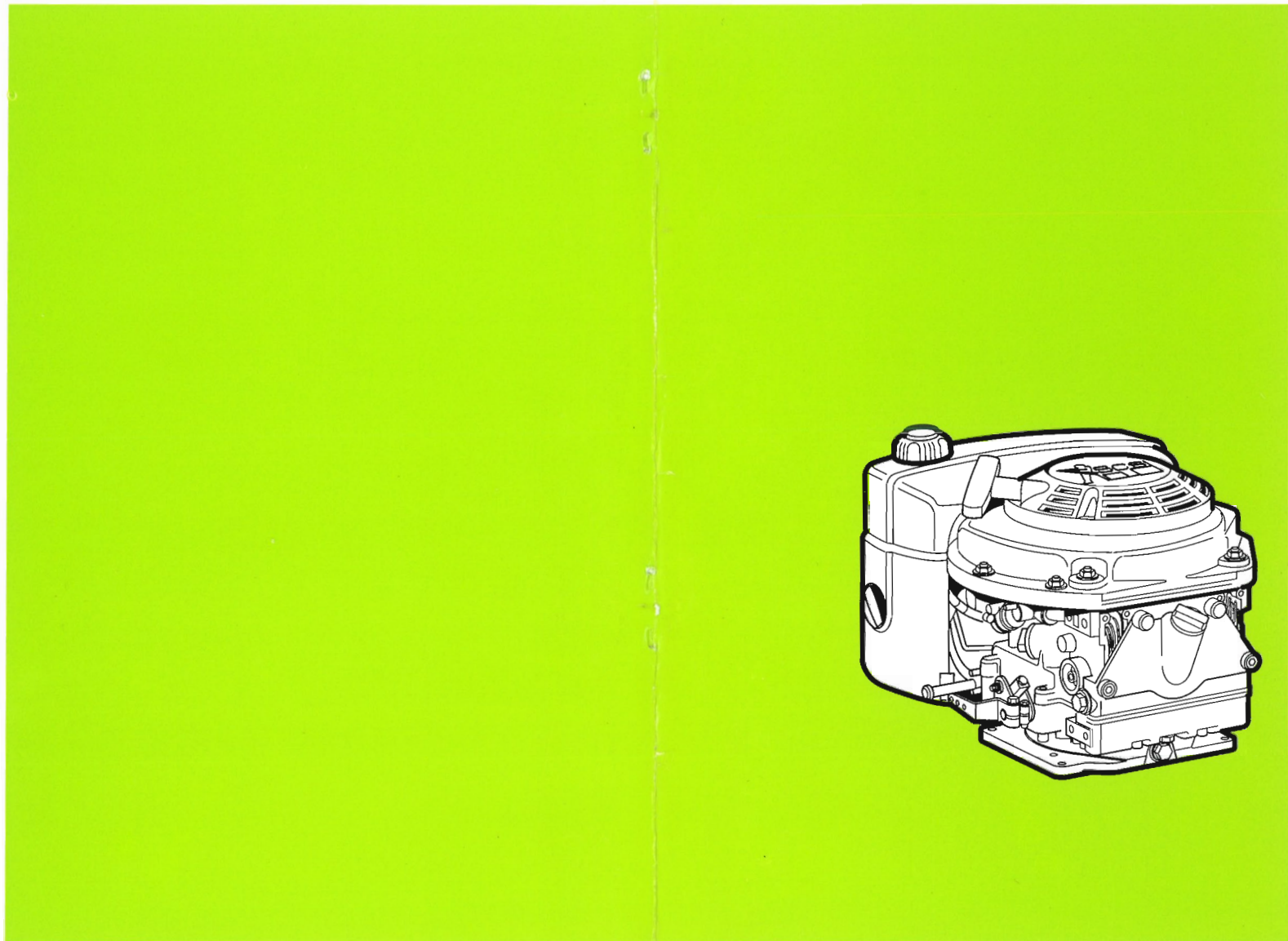

MOTORENFABRIK HATZ • D-94099 Ruhstorf • Germany
Tel.: 0 85 31 / 319-0 • Telefax: 0 85 31 / 31 94 18
eMail: marketing@hatz-diesel.de • <http://www.hatz-diesel.com>

Original-Ersatzteile

Original-spare parts
Pièces de rechange d'origine
Repuestos originales
Pezzi di ricambio originali



43480073 - 04.00 - 0.2
Printed in Germany

1B20V

Bestellung für HATZ-Original-Ersatzteile

Order for HATZ Original spare parts

Commande de pièces d'origine HATZ

Pedido de repuestos originales HATZ

Ordine parti di ricambio originali HATZ

1 Besteller / Customer / Client / Cliente / Cliente

2 TYP

KENNZ.

MOTOR/FABRIK NO.

MIN⁻¹



3 Ersatzteilliste Nr./ Spare parts list no./ Liste des pièces de rechange no./ Lista de repuestos No./ Lista ricambi n.

1 B 20 V. 13

4 Stück / Qty / Q.tà

HATZ Ident No.

Stück / Qty / Q.tà

HATZ Ident No.

5 Versandart / Mode of dispatch / Mode d'expédition / Despacho deseado / Modo di spedizione

Post / Surface / Poste / Correo / Posta Luftfracht / airfreight / frêt aérien / flete aereo / Via aerea
Express / express / exprès / expreso / Espresso

6 Versandadresse / Consignee / Adresse destination / Dirección / Indirizzo di destinazione

Bestellung an: Order at: Commande à: Pedido a:

- die nächste HATZ-Servicestelle (siehe Servicestellenverzeichnis)
- your nearest HATZ service station (see service-list)
- votre station-service HATZ la plus proche (voir liste "Service")
- al servicio HATZ más cercano (ver cuaderno de Servicio)
- al più vicino centro di servizio HATZ (vedi lista centri autorizzati)

**MOTORENFABRIK HATZ
D-94099 RUHSTORF**

Tel: 0 85 31 / 319 - 0

Fax: 0 85 31 / 31 94 21

	Inhaltsverzeichnis	Index	
..	Grundmotor	Basic engine	
0	Ersatzteilsätze	Spare part kits	01
4	Zubehör	Accessories	02
1	Kurbelgehäuse	Crankcase	03
2	Kurbelwelle	Crankshaft	04
4	Nockenwelle	Camshaft	05
5, 06	Kolben, Pleuel, Zylinder	Piston, conrod, cylinder	06
7	Zylinderkopf	Cylinder head	07
0, 32	Ölpumpe, Regler	Oil pump, governor	
	Drehzahlverstellung	speed control	08
1	Steuerdeckel	Timing cover	09
3,17	Gebälse, Schwungrad	Blower, flywheel	10
4	Einspritzausrüstung	Injection equipment	11
5	Reversierstarter	Recoil starter	12
6	Luftführung 1 B 20	Air ducting 1 B 20	13
1	Kurbelgehäuseentlüftung	Crankcase breathing system	14
..	Zusatzausrüstung	Equipments	
1	Kraftstoffbehälter	Fuel tank	15
2	Luftfilter	Air filter	16
3	Abgasdämpfer 1 B 20	Exhaust silencer 1 B 20	17
5	Starter,Generator,	Starter, alternator,	18
5, 10	Armaturen, Leitungen	Electric equipment, wirings	19
0	Motorausrüstung EPA	Spec. equipment EPA	20

	Sommaire:	Indice	
M ..	Moteur de base	Motor de base	
00	Jeu de pièces de rechange	Juegos de piezas de recambios	01
34	Accessoires	Accesorios	02
01	Carter moteur	Caja cigueñal	03
02	Vilebrequin	Cigueñal	04
04	Arbre à cames	Arbol de levas	05
05, 06	Piston, bielle, cylindre	Émbolo, biela, cilindro	06
07	Culasse	Culata	07
10, 32	Pompe à huile, regulateur regime, réglage regime	Bomba de aceite, regulador, ajuste de revoluciones	08
11	Couvercle distribution	Tapa de mando	09
13,17	Soufflerie, volant	Ventilador, volante	10
14	Equipment d'injection	Equipo de inyección	11
15	Demarreur reversible	Arrancador reversible	12
26	Carter ventilation 1 B 20	Conducción de aire 1 B 20	13
31	Reniflard	Purgador	14
A ..	Accessoires	Equipos	
01	Reservoir à carburant	Depósito combustible	15
02	Filtre à air	Filtro de aire	16
03	Silencieux 1 B 20	Silenciador 1 B 20	17
05	Demarreur, alternateur	Arrancador, alternador	18
05, 10	Equipement électrique, cable	Equipo eléctrico, cables	19
90	Equipm. spec. EPA	Equipo espec. EPA	20

1 .. Motore de base

0	Serie guarnizioni	01
4	Kit accessori	02
1	Basamento motore	03
2	Albero a gomito	04
4	Albero a camme	05
5, 06	Pistone, biella, cilindro	06
7	Testa	07
0, 32	Pompa olio, regolatore di giri, Comando acceleratore	08
1	Coperchio distribuzione	09
3, 17	Ventilatore, volano	10
4	Equipaggiamento di iniezione	11
5	Avviamento a strappo	12
6	Carter ventilatore 1 B 20	13
1	Sfiato basamento	14

1 .. Accessori

1	Serbatoio	15
2	Filtro aria	16
3	Scarico 1 B 20	17
5	Motorino avviamento, alternatore,	18
5, 10	Equipaggiam. elettrico, cablaggio	19
0	Kit trasformazione EPA	20

M 00

Ersatzteilsätze
Spare part kits
Jeux de pièces de rechange
Juegos de piezas de recambios
Serie guarnizioni

Tafel Nr.
Tabl. No.
Tavola N.

01

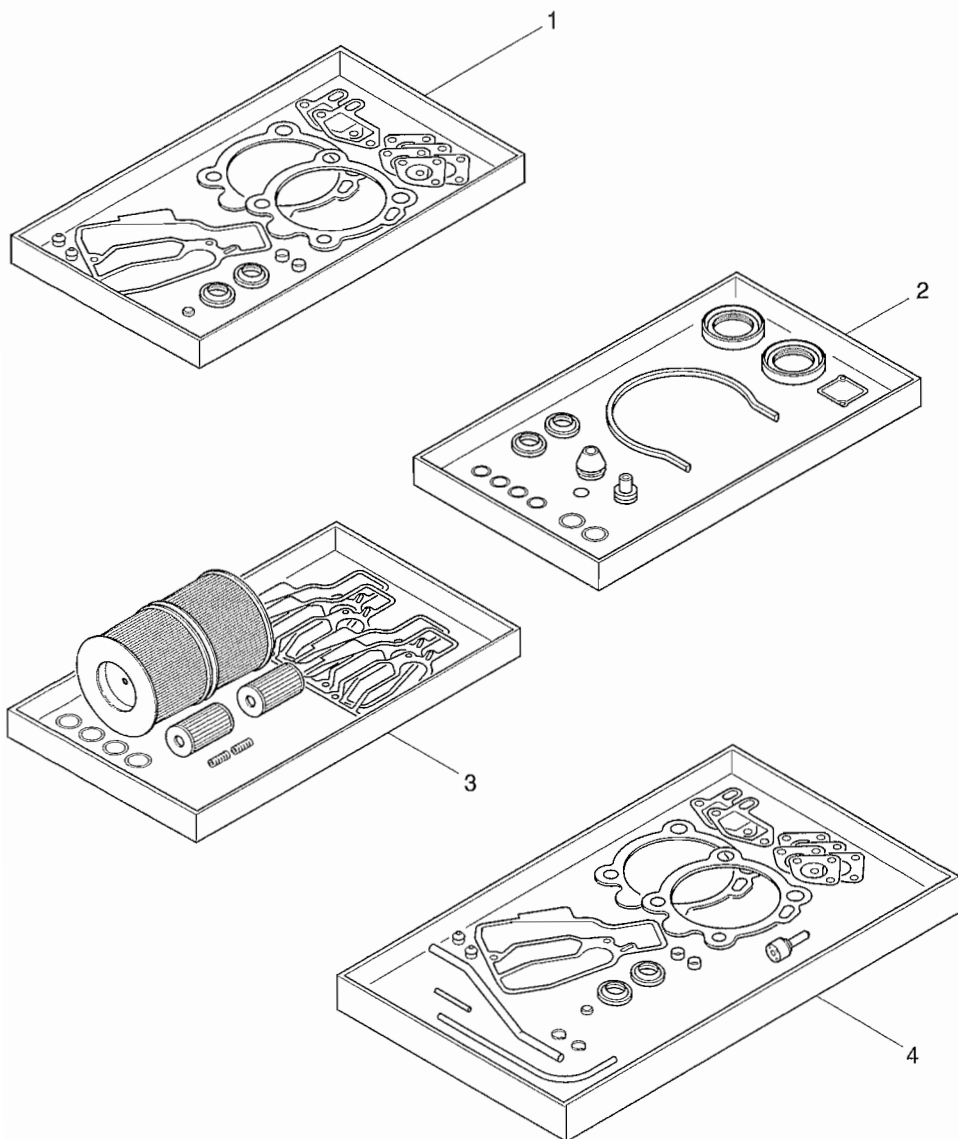

Fig.-No.	HATZ Ident.-No.	Stück Qty.	P / W d / D	Bemerkungen Notes
		1B20V		
V:	Im Wartungssatz enthalten. Incl. in maintenance kit. Contenu dans le jeu d'entretien. Incluido en el juego de mantenimiento. Contenuto nella serie manutenzione.			P: Im Pannensatz enthalten. Incl. in emergency kit. Contenu dans le jeu secur. Incluido en el juego para averias. Contenuto nella serie di prima necessità.
:	Im Dichtungssatz f. 1 Zyl.-Kopf enthalten. Incl. in gasket set f. 1 cyl. head. Contenu dans le jeu de joint p. 1 culasse. Incluido en el juego de juntas p. 1 culata. Contenuto nella serie guarnizioni p. 1 testa.			D: Im Dichtungssatz Kurbelgeh. Incl. in gasket set crankcase. Contenu dans le jeu de joints carter moteur. Incluido en el juego de juntas caja cigueñal. Contenuto nella serie guarnizioni basamento.
				1: Anzahl pro Satz - Qty. per kit Quantite p. jeu - Cantidad p. juego. Quantità per serie
	015 541 00	1	P 1	Dichtungssatz für 1 Zylinderkopf Gasket set for 1 cyl. head Jeu de joint p. 1 culasse Juego de juntas para 1 culata Serie guarniziono per 1 testa
	015 542 00	1		Dichtungssatz für Kurbelgehäuse Gasket set for crankcase Jeu de joints p. carter moteur Juego de juntas para caja cigueñal Serie guarnizioni basamento
	015 543 00	1		Wartungssatz für 1000 h 1000 hours maintenance kit Kit d'entretien 1000 heures - Juego de piezas para servicio 1000 horas Kit di manutenzione a 1000 ore
	015 544 10	1		Pannensatz - Emergency kit Kit de secours - Juego para averias Kit di prima necessità

M 34

Zubehör
 Accessoires
 Accessorios
 Accessorios
 Kit accessori

Tafel Nr.
 Tabl. No.
 Tavola N.

02

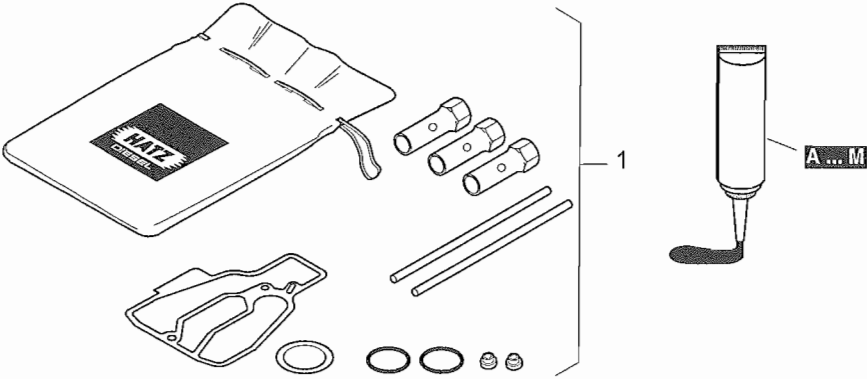

HATZ DIESEL

WARTUNG - MAINTENANCE
 ENTRETIEN - MANUTENZIONE
 MANUTENZIONE

8-15 250

STUNDEN - HEURES - HEURES
 HORAS - ORE

500

NEI NECESSARI
 IF NECESSARY
 SI NECESSARIO
 EN CAS DE
 NECESSARIO
 SE NECESSARIO

IN
 0.1 mm
 0.004"

051 104 01

1B20

2

COMPR.

1

2

START

3

051 300 00

3



4

Fig.-No.	HATZ Ident.-No.	Stück Qty.	P / W d / D	Bemerkungen Notes
		1B20V		
1	013 310 01	1		Zubehörsatz - Accessoires kit Sort. accessoires Juego de accesorios Serie accessorie
2	051 104 01	1		160 x 67 mm
3	051 300 00	1		
4	051 301 00	1		

Dicht- und Klebstoffe Sealing- and bonding adhesives Etanchéifiant et Colle			Materias para empaquetar y pegar Adesivi e collanti	
A =	502 230 01	Loctite Activator N	500 ml	} siehe Hinweis auf den einzelnen Bildtafeln as specified in the individual tables suivant les remarques sur les tableau correspondant según las indicaciones de las tablas correspondientes seguire le indicazioni sul quadro corrispondente
B =	502 231 00	Loctite 573	50 ml	
C =	502 232 00	Loctite 601	50 ml	
D =	502 233 00	Loctite 221	50 ml	
E =	502 234 00	Loctite 648	10 ml	
F =	502 238 00	Technicoll 8058	0,75 kg	
G =	502 239 00	Technicoll 8367	0,75 kg	
H =	502 565 01	Loctite IS 407	20 g	
I =	502 825 01	Silicon	30 ml	
J =	502 830 03	Hochtemp. Paste	100 ml	
K =	503 426 00	Hochtemp. Fett	100 g	
L =	502 566 00	Silicon sealer	100 g	
M =	504 851 00	Schleifpaste	80 g	

M 01

Kurbelgehäuse 1B20V
Crankcase 1B20V
Carter moteur 1B20V
Caja cigueñal 1B20V
Basamento motore 1B20V

Tafel Nr.
Tabl. No.
Tavola N.

03

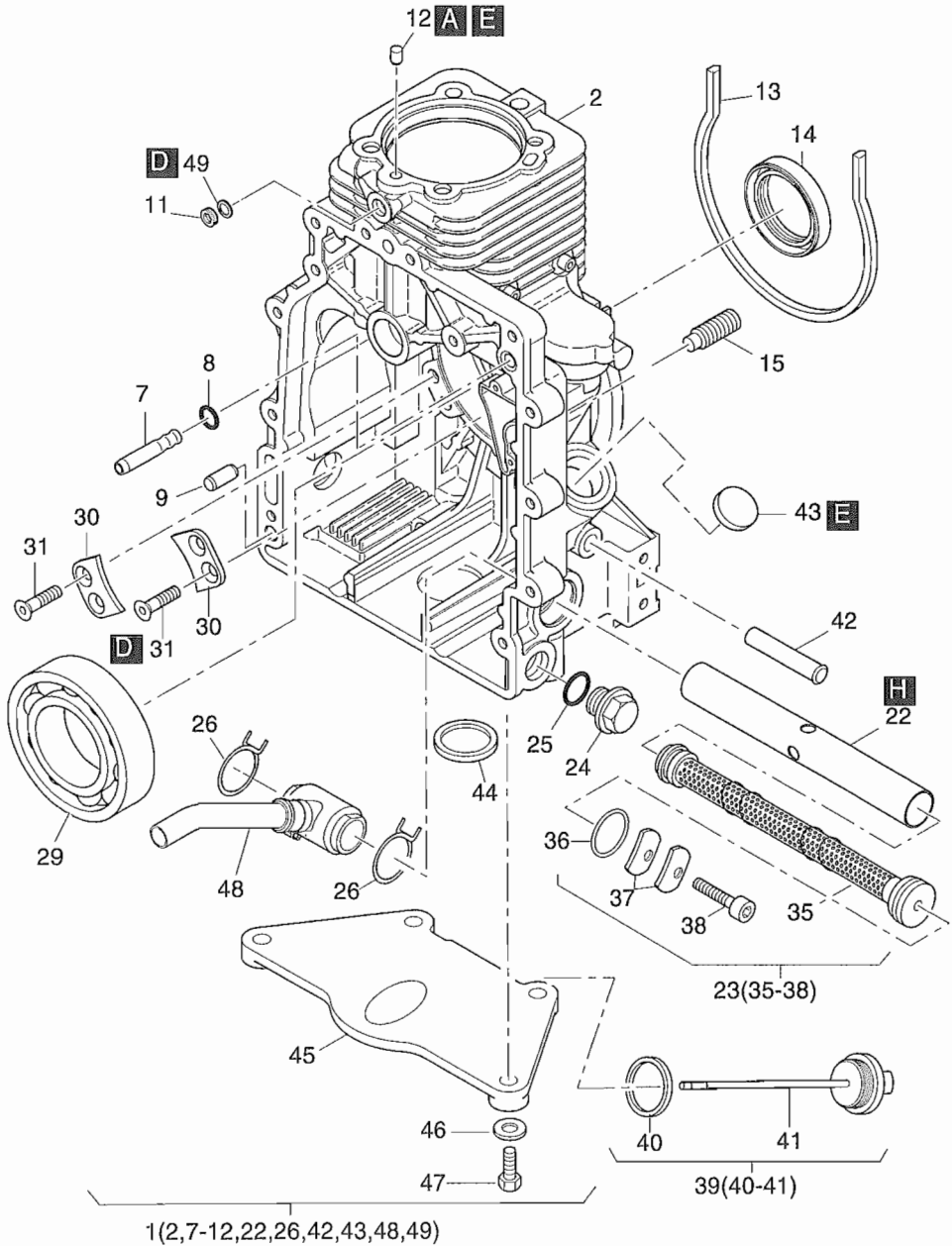

Fig.-No.	HATZ Ident-No.	Stück Qty.	P / W d / D	Bemerkungen Notes
		1B20V		
1	016 250 10	1		
2	-----	-		
7	050 843 00	1		
8	504 403 00	1	D1	8 x 1,5
9	502 491 01	1		8 m 6 x 20
10	-----	-		
11	500 623 00	1		M 10 x 1 DIN 908-5.8 A3C
12	-----	-		
13	040 980 00	1	D1	315 mm
14	504 232 00	1	D1	40 x 55 x 10 AS
15	041 152 00	1		M 12 x 1,5 x 35 45 H A3C TUF 360
22	041 057 10	1		
23	015 427 02	1		
24	503 731 00	1	W1	AM 22 x 1,5 MAGN.
25	504 698 00	1	D2, W4	A 22 x 27 DIN 7603 - Vf
26	050 369 00	2		
29	504 233 00	1		
30	040 944 00	2		
31	503 280 00	4		AM 6 x 16 17065-8.8 Zn
35	-----	-		
36	504 759 01	1		20 x 4
37	051 482 00	2		
38	501 707 00	1		M 6 x 16 DIN 912-8.8 A3C
39	013 392 00	1		
40	041 250 00	1		26 x 35 x 3
41	-----	-		
42	-----	-		
43	-----	-		
44	503 292 00	1		50 x 55 x 3
45	051 444 00	1		
46	501 157 00	4		8,4 DIN 433-St 140 HV
47	503 663 00	4		M 8 x 20 DIN 912-8.8 A3C
48	013 398 00	1		
49	500 624 00	1		A 10 x 13,5 DIN 7603-Cu

M 02

Kurbelwelle
Crankshaft
Vilebrequin
Cigüeñal
Albero a gomito

Tafel Nr.
Tabl. No.
Tavola N.

04

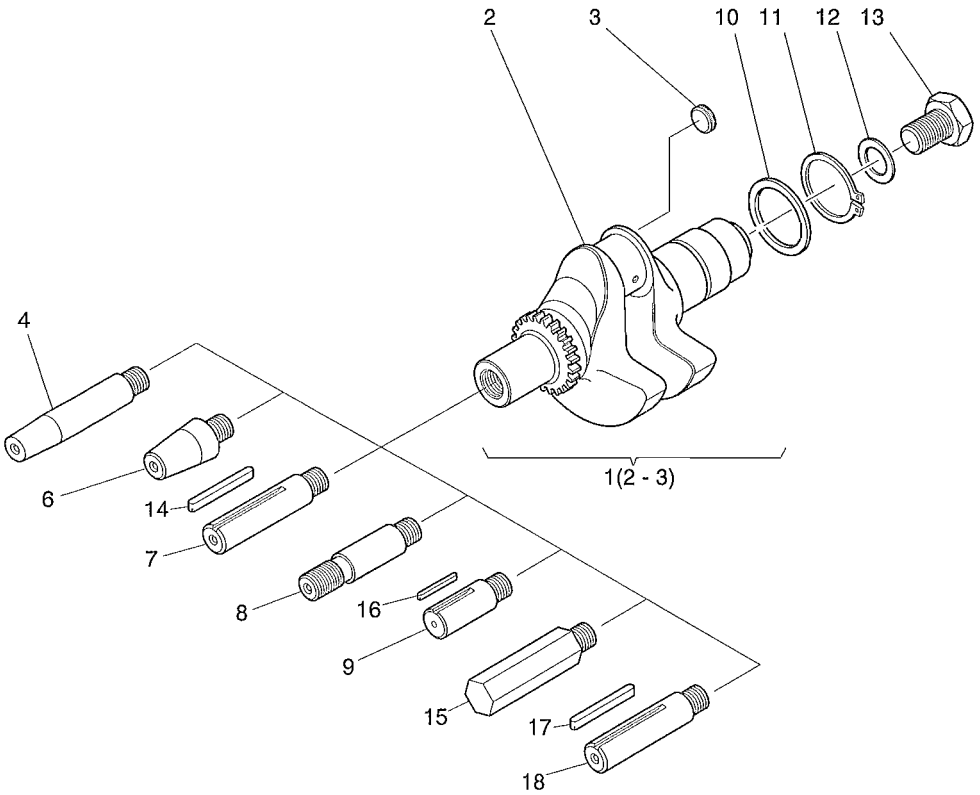

Fig.-No.	HATZ Ident-No.	Stück Qty.	P / W d / D	Bemerkungen Notes
1B20V				
1	013 403 00	1		1 B 20 V „X“
2	-----	-		
3	041 253 00	1		
4	050 996 00	1		Nr. 4 SAE Generator
5	-----	-		
6	050 997 00	1		Nr. 6 ital. 23 keg., con.
7	050 998 00	1		Nr. 7 3/4" zyl., cil.
8	050 999 00	1		Nr. 8 SAE 3/4 - 16 UNF
9	051 000 00	1		Ø 20 zyl., cil.
10	400 325 00	1		40 x 50 x 2,5 DIN 988
11	501 206 00	1		A 40 x 1,75 DIN 471
12	041 142 01	1		18,5 x 37 x 5
13	504 436 00	1		M 18 x 1,5 x 55 DIN 961-10.9
14	041 204 00	1		4,75 x 30
15	051 073 01	1		27 mm
16	504 634 00	1		A 5 x 5 x 36 DIN 6885
17	504 634 00	1		A 5 x 5 x 36 DIN 6885
18	041 525 00	1		

M 04

Nockenwelle
Camshaft
Arbre à cames
Arbol de levas
Albero a camme

Tafel Nr.
Tabl. No.
Tavola N.

05

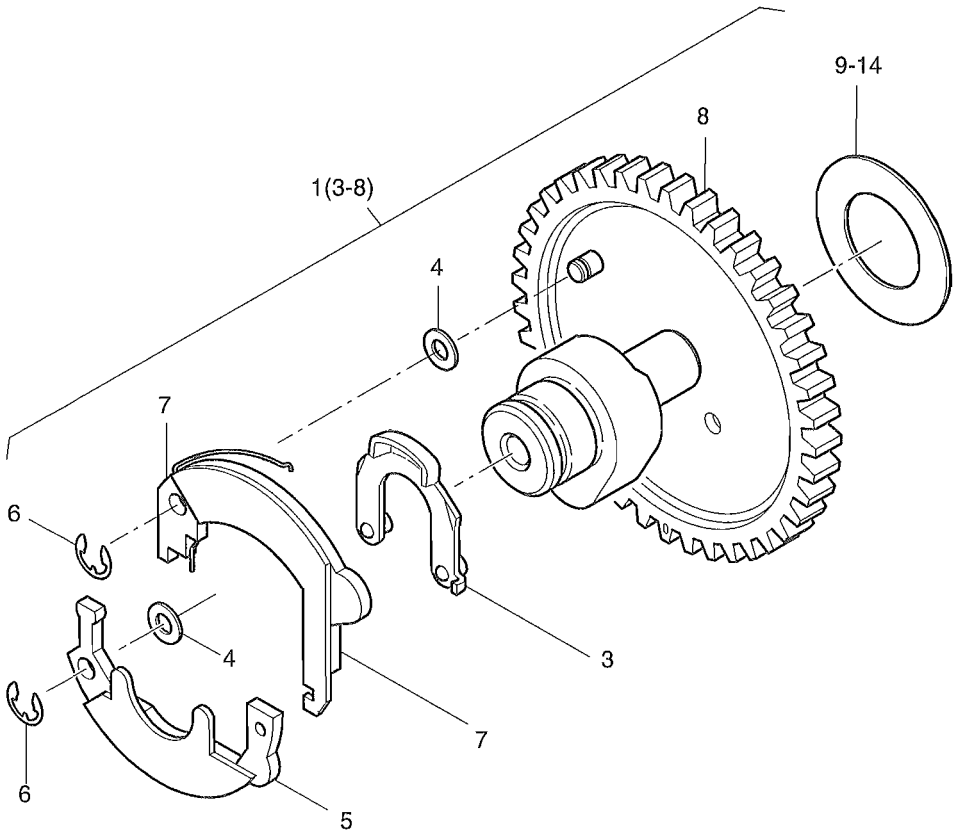

Fig.-No.	HATZ Ident-No.	Stück Qty.	P / W d / D	Bemerkungen Notes
		1B20V		
1	016 404 00	0...1		Handstart
1	016 403 00	0...1		E - Start
2	-----	-		
3	013 264 00	1		
4	501 232 00	2		5 x 10 x 0,5 DIN 988
5	013 266 00	1		
6	502 553 00	2		3,2 DIN 6799
7	013 265 00	1		
8	-----	-		
9	041 217 00	0...1		0,9 mm 23 x 38 x 0,9
10	041 121 00	0...1		1,0 mm 23 x 38 x 1,0
11	041 122 00	0...1		1,1 mm 23 x 38 x 1,1
12	041 123 00	0...1		1,2 mm 23 x 38 x 1,2
13	041 251 00	0...1		1,3 mm 23 x 38 x 1,3
14	041 252 00	0...1		1,4 mm 23 x 38 x 1,4

M 05

Kolben, Pleuel
Piston, Conrod
Piston, bielle
Embolo, biela
Pistone, biella

M 06

Zylinder
Cylinder
Cylindre
Cilindro
Cilindro

Tafel Nr.
Tabl. No.
Tavola N.

06

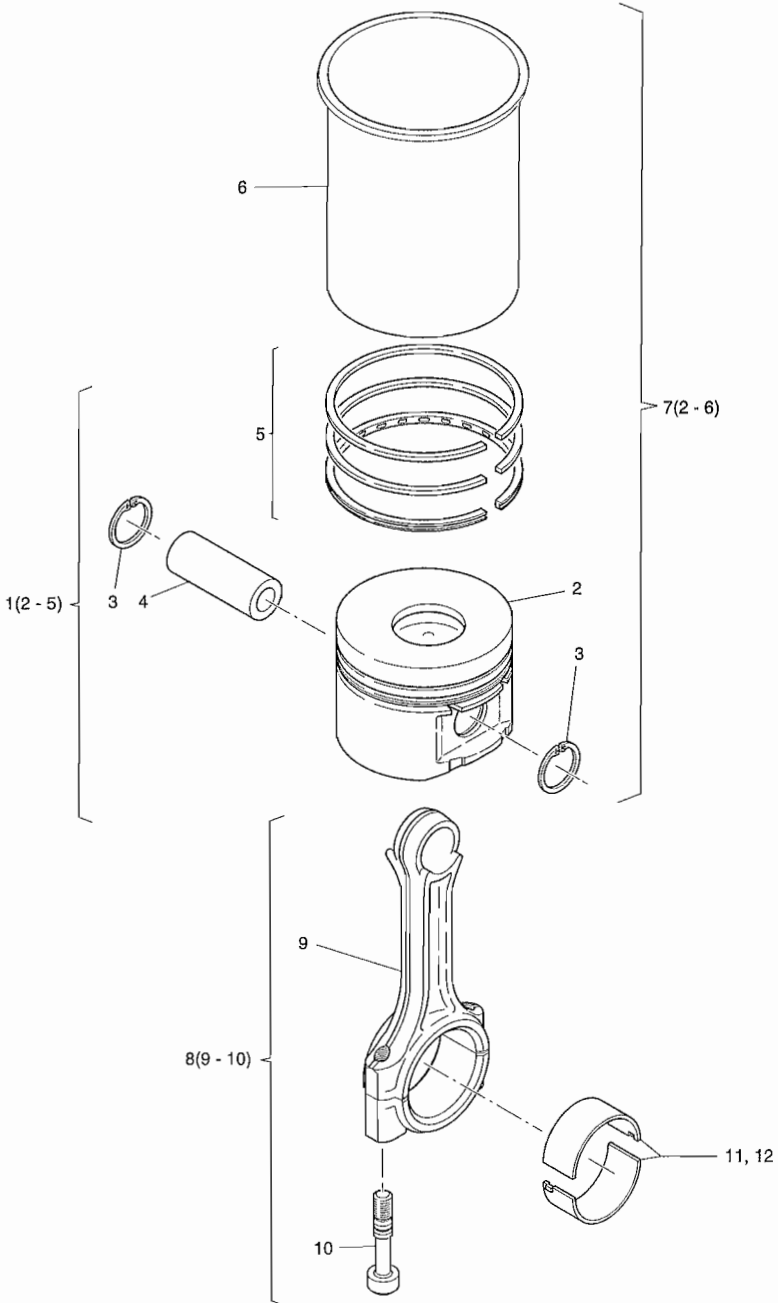

Fig.-No.	HATZ Ident-No.	Stück Qty.	P / W d / D	Bemerkungen Notes
		1B20V		
1	013 498 00	1		69 mm
2	-----	-		
3	504 255 00	2		
4	-----	-		
5	013 172 00	1		
6	-----	-		
7	015 545 10	1		
8	015 001 00	1		
9	-----	-		
10	050 469 00	2		
11	015 757 00	1		
12	015 819 00	1		-0,5 mm

M 07

Zylinderkopf
Cylinder head
Culasse
Culata
Testa

Tafel Nr.
Tabl. No.
Tavola N.

07

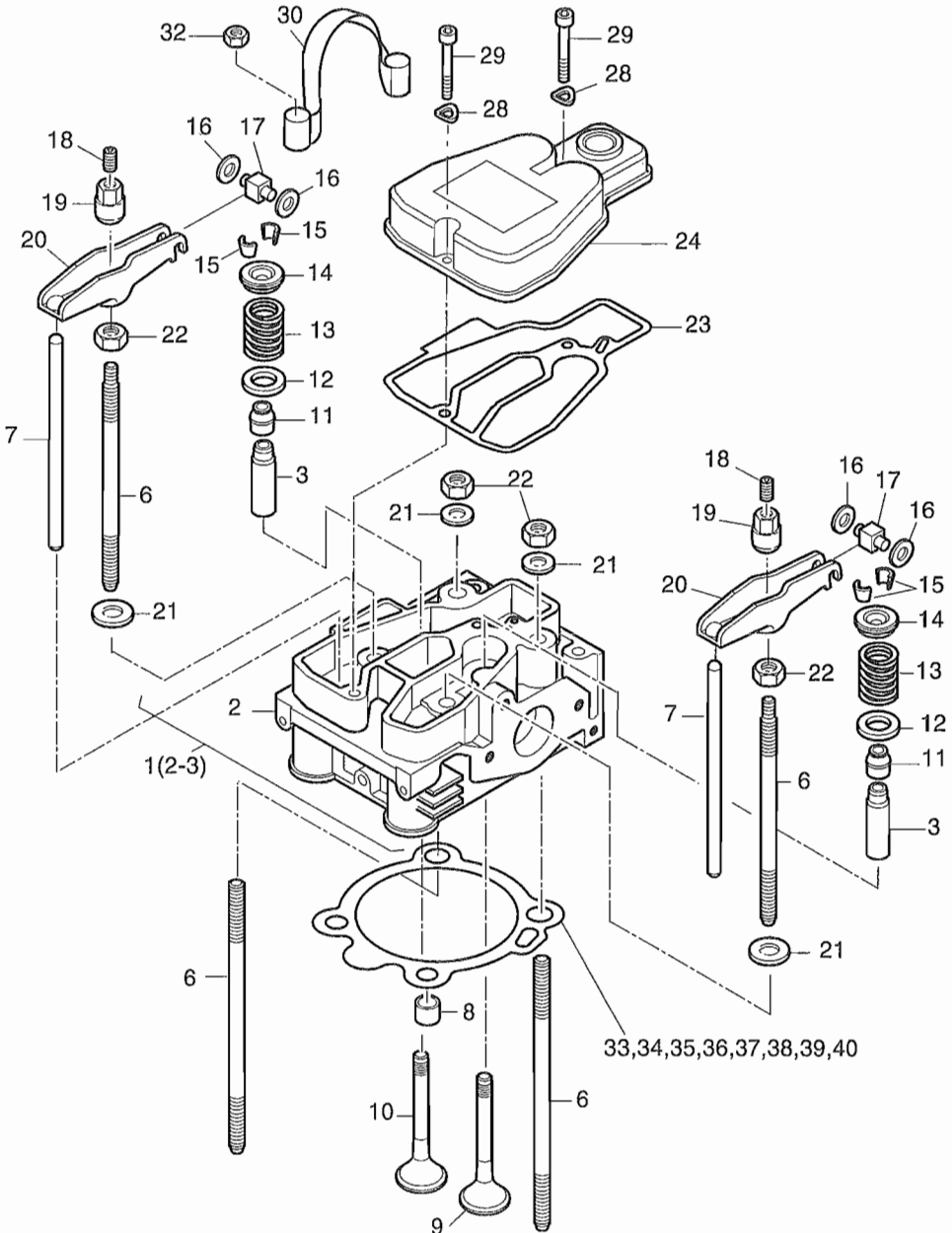

Fig.-No.	HATZ Ident.-No.	Stück Qty.	P / W d / D	Bemerkungen Notes
		1B20V		
1	015 002 40	1		
2	-----	-		
3	051 194 00	2		
6	050 625 00	4		128 mm (M 8)
7	050 540 00	2		
8	041 075 00	2	d2	
9	050 532 00	1		
10	050 533 00	1		
11	504 258 00	2	d2	
12	040 937 00	2		
13	040 936 00	2		
14	040 938 00	2		
15	504 257 00	2		
16	504 451 00	4		6 x 12 x 1,2 DIN 988
17	050 911 01	2		
18	503 580 00	2	W2	M 8 x 10 DIN 913 - A3C Tuf.
19	050 547 00	2		
20	050 509 00	2		
21	050 612 01	4		8,1 x 20 x 3
22	503 643 00	4		M 8 DIN 934 - 10.9 A3C
23	050 557 00	1	d1, W4	
24	050 473 20	1		
28	500 812 00	2		A6 DIN 137 - A3C
29	503 749 00	2		M 6 x 35 DIN 912 - 8.8 A3C
30	041 176 00	1		
32	501 295 00	2		M 8 DIN 985 - A3C
33	050 594 00	0...1		0,3 mm
34	050 595 00	0...1		0,4 mm
35	050 596 00	0...1	d1	0,5 mm
36	050 597 00	0...1	d1	0,6 mm
37	050 598 00	0...1		0,7 mm
38	050 599 00	0...1		0,8 mm
39	050 600 00	0...1		0,9 mm
40	050 601 00	0...1		1,0 mm

M 10

Ölpumpe, Regler
Oil pump, governor
Pompe à huile, régulateur
Bomba de aceite, regulador
Pompa olio, regolatore

M 32

Drehzahlverstellung
Speed control
Réglage régime
Ajuste de revoluc.
Regolatore di giri

Tafel Nr.
Tabl. No.
Tavola N.

08

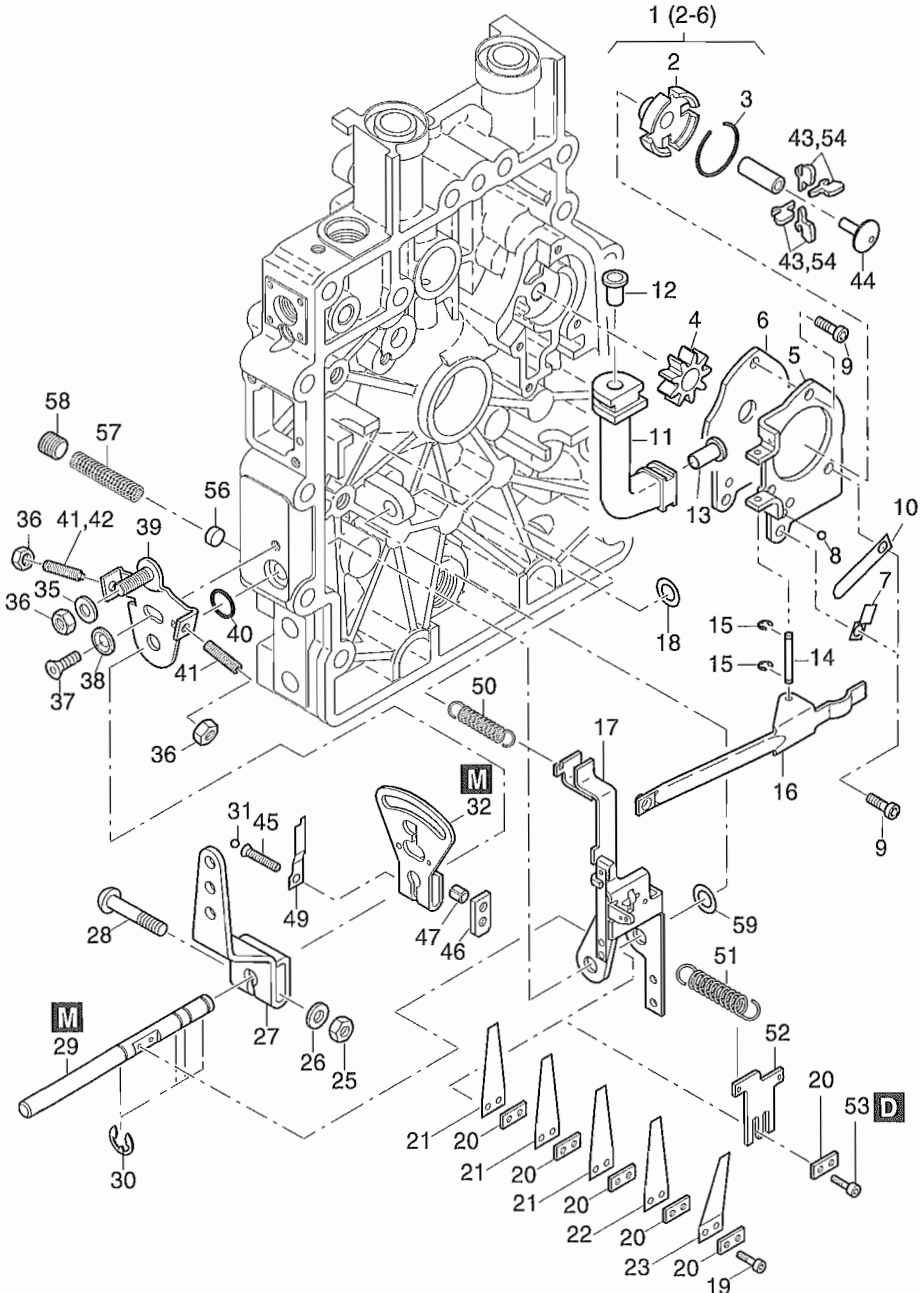

Fig.-No.	HATZ Ident-No.	Stück Qty.	P / W d / D	Bemerkungen Notes
1B20V				
1	015 302 10	1		
2	-----	-		
3	504 349 01	1		RB25 DIN 7993
4	-----	-		
5	-----	-		
6	-----	-		
7	050 971 00	1		
8	504 479 00	1		3,5 mm Kl. III
9	504 294 00	4		M 5 x 12 DIN 6912 - 8.8
10	050 973 00	1		0,4 mm
11	041 029 00	1		
12	504 474 00	1		A 8 x 0,5 x 12 DIN 7340 - St
13	504 475 00	1		A 10 x 0,75 x 12 DIN 7340 - St
14	050 786 00	1		
15	504 348 00	2		1,9 DIN 6799
16	050 794 00	1		
17	015 304 03	1		
18	501 258 00	1...2		8 x 14 x 0,5 DIN 988
19	504 350 00	2		M 3 x 12 DIN 912 - 8.8
20	050 798 00	1...5		
21	051 316 00	1...2		0,2 mm } Gen.-PV 78
22	050 789 00	1...2		0,3 mm } 951 385 00
23	051 486 00	1		0,4 mm 19° ∠ }
25	501 444 00	1		M 6 DIN 934 - 8 A3C
26	501 445 00	1		6,4 DIN 125 - St A3C
27	040 956 00	1		
28	039 273 00	1		M 6 x 32
29	050 793 01	1		
30	500 927 00	4		7 DIN 6799 A3C
31	503 471 00	1		∅ 3,175
32	013 330 00	1		
35	501 445 00	1		6,4 DIN 125-St A3C
36	501 444 00	3		M 6 DIN 934 - 8 A3C
37	504 239 00	1		M 6 x 20 DIN 7991-10.9 A3C
38	041 229 00	1		

M 10

Ölpumpe, Regler
Oil pump, governor
Pompe à huile, regulateur
Bomba de aceite, regulador
Pompa olio, regolatore

M 32

Drehzahlverstellung
Speed control
Réglage régime
Ajuste de revoluc.
Regolatore di giri

Tafel Nr.
Tabl. No.
Tavola N.

08

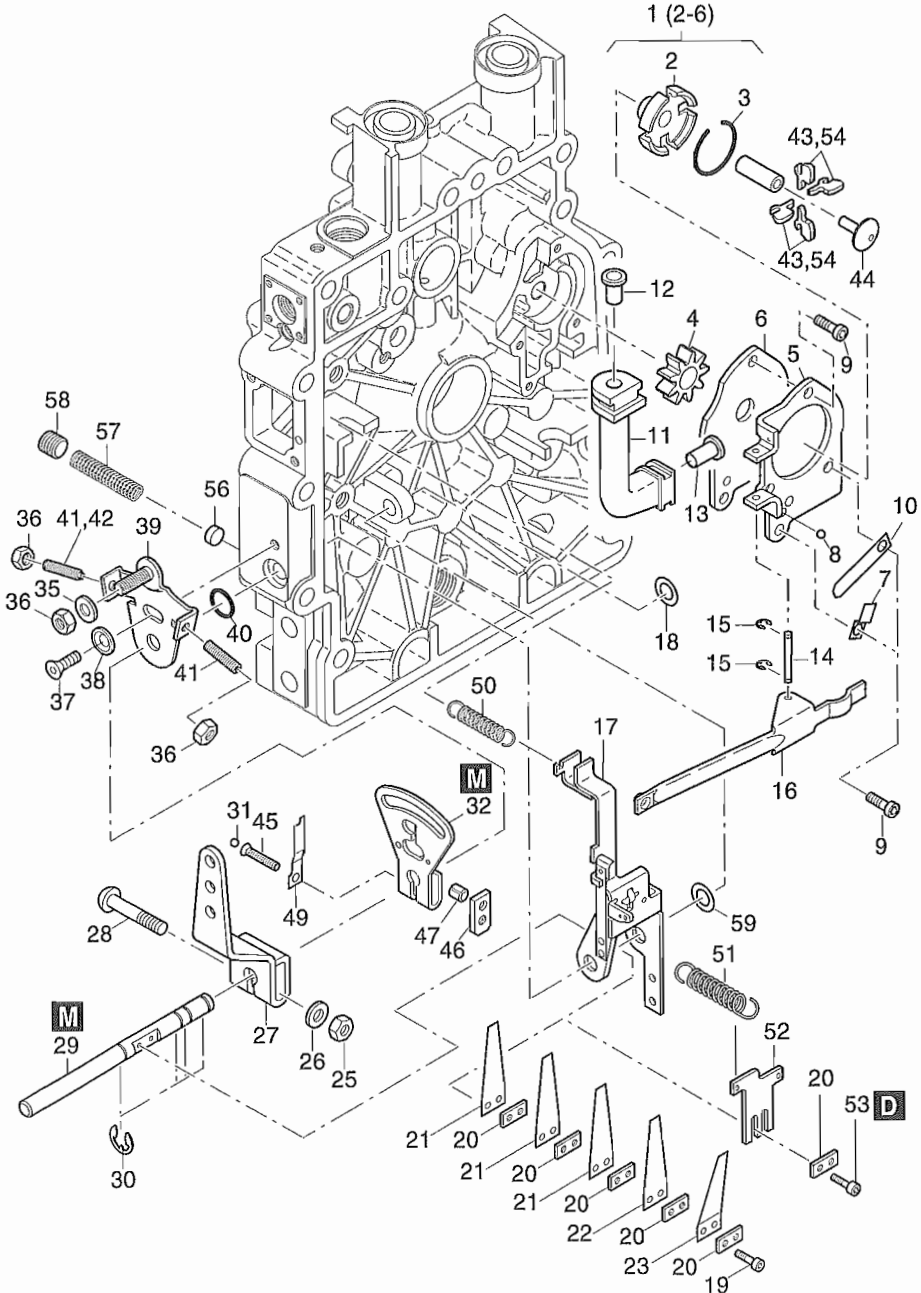

Fig.-No.	HATZ Ident-No.	Stück Qty.	P / W d / D	Bemerkungen Notes
		1B20V		
39	013 164 02	1		
40	400 224 01	1		8 x 2 FPM 75 MOLYKOT.
41	501 381 00	1...2		M 6 x 35 DIN 915 - 45H
41	504 894 00	0...1		M 6 x 40 DIN 915 - 45H
42	500 042 00	0...1		M 6 x 20 DIN 915 - 45H
43	050 796 02	8		
44	050 785 01	1		
45	504 753 00	1		M 5 x 25 ISO 7380-10.9 Zn
46	051 513 00	1		
47	504 754 00	1		5 x 8 DIN 7346
49	041 228 00	0...1		
50	040 002 00	1		
51	051 309 00	1		
52	051 308 00	1		
53	504 653 00	2		M 3 x 8 DIN 912 - 8.8
54	051 602 02	4		} Gen.-PV 78 8 x 3,2 x 0,5
54	050 796 02	4		
56	051 517 00	1		
57	504 887 00	1		
58	504 757 00	1		M 10 x 10 DIN 913 - A3C Tuf.
59	504 224 00	1		8 x 14 x 1,0 DIN 988

M 11

Steuerdeckel
Timing cover
Couvercle distribution
Tapa de mando
Coperchio distribuzione

Tafel Nr.
Tabl. No.
Tavola N.

09

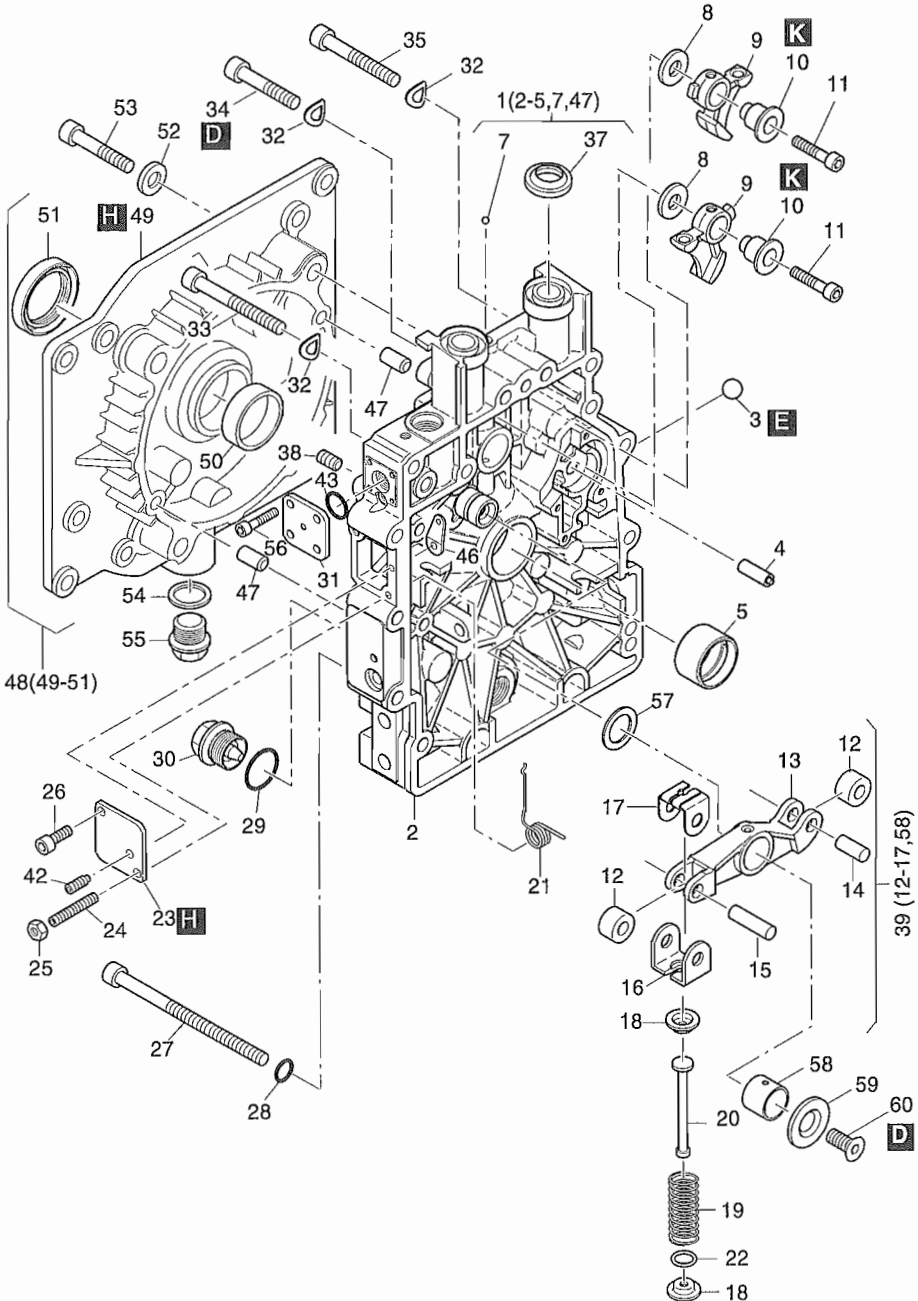

Fig.-No.	HATZ Ident-No.	Stück Qty.	P / W d / D	Bemerkungen Notes
1B20V				
1	013 401 10	1		
2	-----	-		
3	-----	-		
4	015 339 00	1		
5	050 531 00	1		
5	041 248 00	1		-0,5 mm
7	504 434 00	1		5,5 G20 DIN 5401
8	037 941 00	2		
9	050 534 00	2		
10	037 942 01	2		
11	504 579 00	2		M 6 x 25 DIN 912 - 10.9
12	-----	-		
13	-----	-		
14	-----	-		Pos. 39 (12 - 17)
15	-----	-		
16	-----	-		
17	-----	-		
18	040 948 02	2		
19	040 957 00	1		
20	040 947 00	1		
21	050 952 10	1		
22	041 339 00	1		10,7 x 16 x 0,5
23	040 952 10	1		
24	504 489 01	1		M 6 x 30 DIN 913 22 H A3C Tuf.
25	501 444 00	1		M 6 DIN 934 - 8 A3C
26	503 842 00	1		M 6 x 12 DIN 912 - 8 A3C Tuf.
27	504 261 00	2		M 8 x 120 DIN 912 - 8.8 A3C
28	501 629 00	2	D2	A 8 x 14 DIN 7603 - Cu
29	504 698 00	1	W4, D2	A 22 x 27 DIN 7603 - Vf
30	503 731 00	1	W1	AM 22 x 1,5 MAGN.
31	013 517 00	1		
32	500 951 00	13		A 8 DIN 137 A3C
33	502 488 00	1		M 8 x 60 DIN 912 - 8.8 A3C
34	504 534 00	2		M 8 x 45 DIN 912 - 8.8 A3C Tuf.
35	503 929 00	10		M 8 x 50 DIN 912 - 8.8 A3C
37	041 065 00	2	d2	
38	503 580 00	5		M 8 x 10 DIN 913 - A3C Tuf.
39	013 196 10	1		

M 11

Steuerdeckel
Timing cover
Couvercle distribution
Tapa de mando
Coperchio distribuzione

Tafel Nr.
Tabl. No.
Tavola N.

09

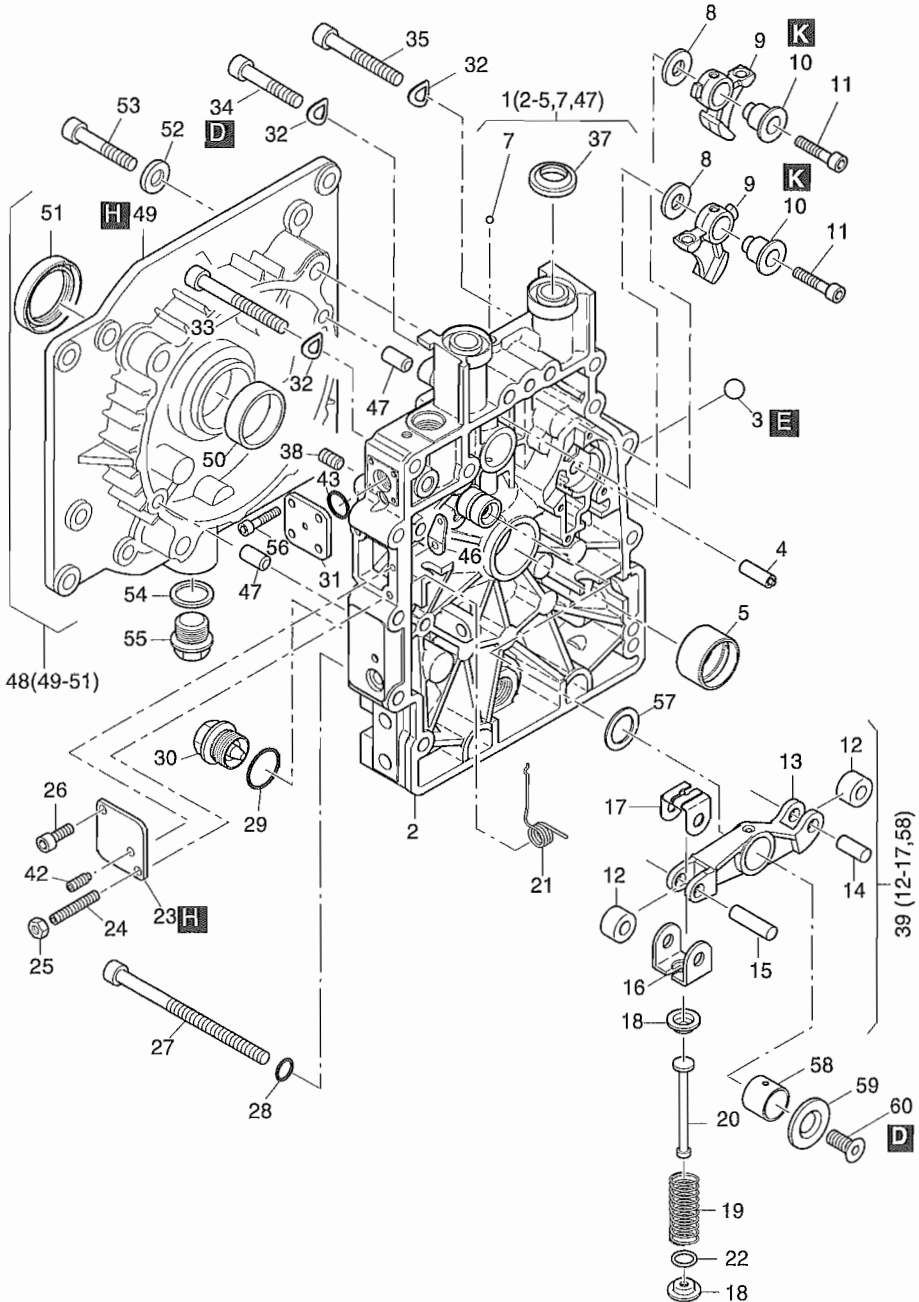

Fig.-No.	HATZ Ident-No.	Stück Qty.	P / W d / D	Bemerkungen Notes
		1B20V		
42	502 749 01	1		M 4 x 20 DIN 915 - Tuf. 360 G
43	503 290 00	1		9,5 x 2,5
46	051 271 00	1		
47	502 491 01	2		8 m 6 x 20 DIN 6325
48	016 267 01	1		
49	-----	-		
50	501 934 00	1		
51	400 337 00	1		30 x 47 x 8
52	500 170 00	4		10,5 DIN 433 - St A3C
53	504 755 00	4		M 10 x 45 DIN 6912 - 8.8 A3C
54	500 014 00	1		A 18 x 22 DIN 7603 - Cu
55	500 442 00	1		M 18 x 1,5 DIN 910
56	503 971 00	4		M 4 x 10 DIN 912-8.8 A3C
57	504 856 00	1		13 x 19 x 1
58	041 528 00	1		
59	041 527 01	1		
60	504 225 00	1		M 6 x 12 DIN 7991-8.8 A3C

M 13

Gebälse
Blower
Soufflerie
Ventilador
Ventilatore

M 17

Schwungrad
Flywheel
Volant
Volante
Volano

Tafel Nr.
Tabl. No.
Tavola N.

10

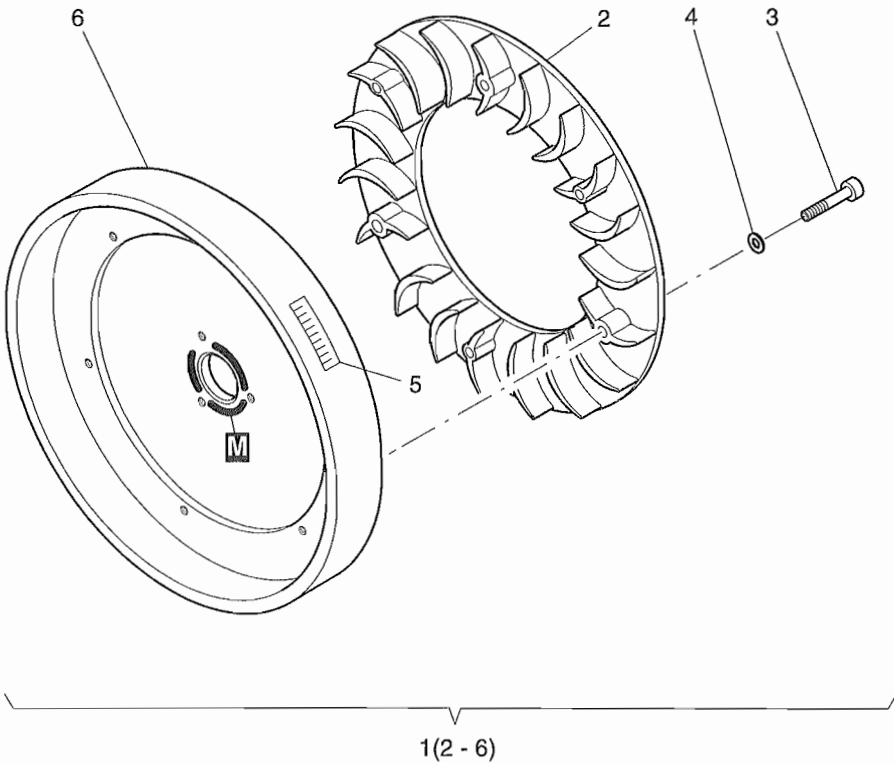

Fig.-No.	HATZ Ident-No.	Stück Qty.	P / W d / D	Bemerkungen Notes
		1B20V		
1	015 797 10	1		
2	013 213 10	1		
3	503 273 00	6		M 4 x 20 DIN 912 - 8.8 A3C
4	500 034 00	6		A 4 DIN 137
5	041 173 00	1		„Handstart“ OT
6	050 522 20	1		

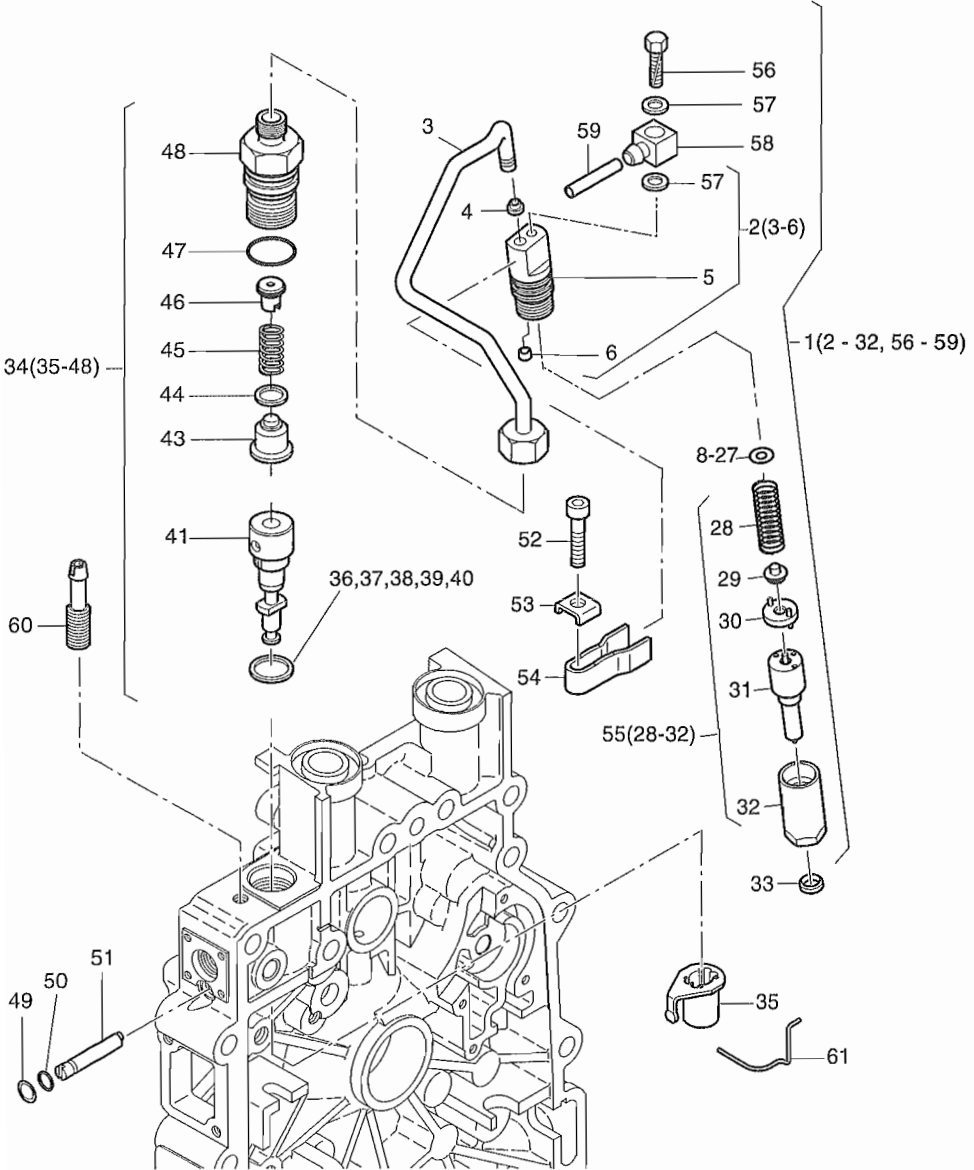

Fig.-No.	HATZ Ident-No.	Stück Qty.	P / W d / D	Bemerkungen Notes
		1B20V		
1	016 216 10	1		
2	015 771 10	1		
3	-----	-		
4	050 961 01	0...1		4,9 mm
4	050 706 01	0...1		5,3 mm
5	-----	-		
6	050 815 00	1		
7	-----	-		
8	504 364 00	0...1		1,00 mm
9	504 365 00	0...1		1,04 mm
10	504 366 00	0...1		1,10 mm
11	504 367 00	0...1		1,14 mm
12	504 368 00	0...1		1,20 mm
13	504 369 00	0...1		1,24 mm
14	504 370 00	0...1		1,30 mm
15	504 371 00	0...1		1,34 mm
16	504 372 00	0...1		1,40 mm
17	504 373 00	0...1		1,44 mm
18	504 374 00	0...1		1,50 mm
19	504 375 00	0...1		1,54 mm
20	504 376 00	0...1		1,60 mm
21	504 377 00	0...1		1,64 mm
22	504 378 00	0...1		1,70 mm
23	504 379 00	0...1		1,74 mm
24	504 380 00	0...1		1,80 mm
25	504 381 00	0...1		1,84 mm
26	504 382 00	0...1		1,90 mm
27	504 383 00	0...1		1,94 mm
28	-----	-		
29	-----	-		
30	-----	-		
31	504 893 00	1	P1	
32	-----	-		
33	050 705 00	1		
34	013 222 10	1		
35	013 308 01	1		
36	040 963 00	0...1		0,2 mm
37	040 964 00	0...1		0,3 mm
38	040 965 00	0...1		0,4 mm

s. 951 258 01

M 14

Einspritzausrstung
Injection equipment
Equipement d'injection
Equipo de inyeccin
Equipaggiamento d'iniezione

Tafel Nr.
Tabl. No.
Tavola N.

11

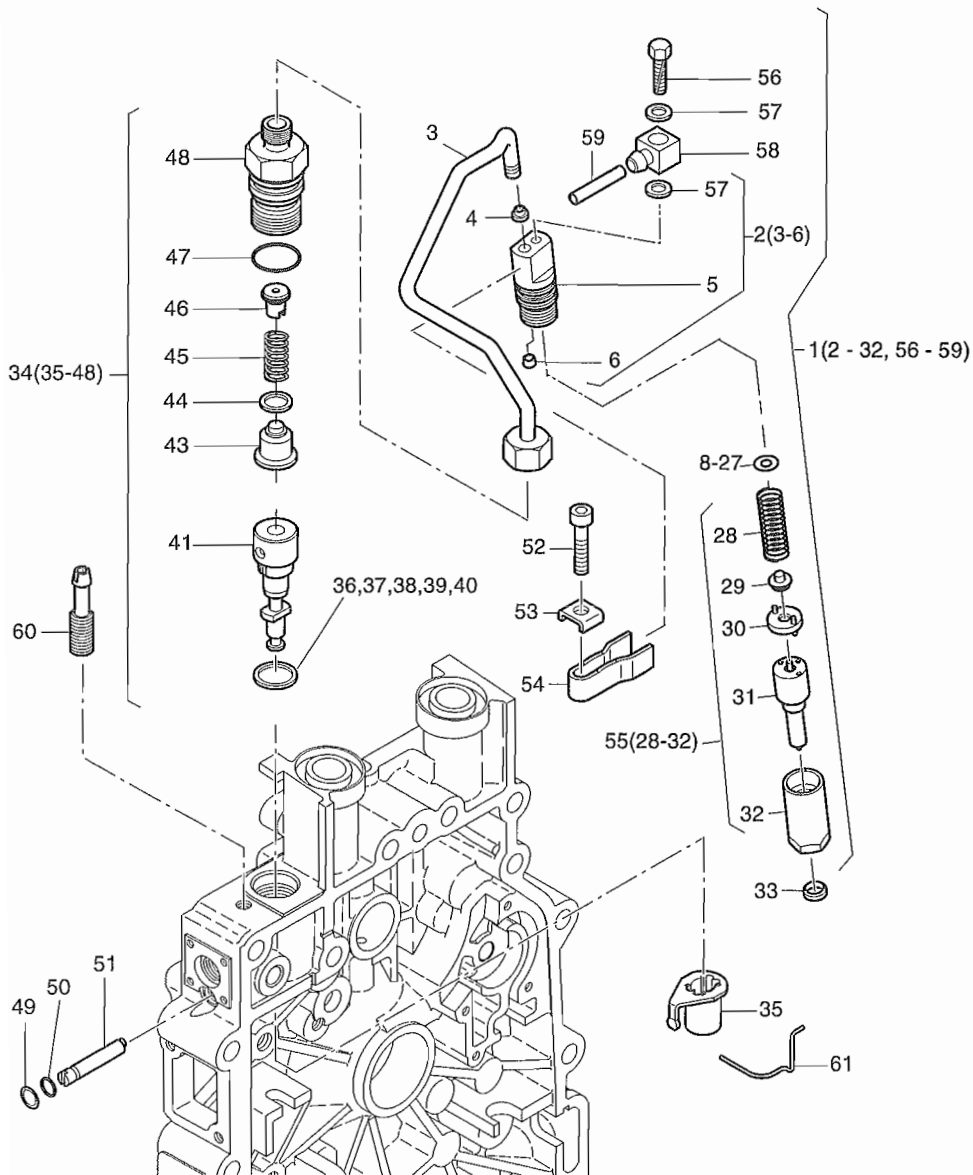

Fig.-No.	HATZ Ident-No.	Stück Qty.	P / W d / D	Bemerkungen Notes
		1B20V		
39	040 966 00	0...1		0,5 mm
40	040 967 00	0...1		0,6 mm
41	-----	-		
43	-----	-		
44	504 769 00	1		9,5 x 13 x 0,5
45	-----	-		
46	-----	-		
47	504 892 00	1		17 x 2
48	504 459 00	1		
49	504 760 00	1		8 DIN 470 Al
50	504 339 00	1		3,3 x 1,0
51	040 977 00	1		
52	503 239 00	1		M 6 x 30 DIN 912 - 8.8 A3C
53	050 893 00	1		6,4
54	050 567 00	1		
55	016 554 00	1		
56	504 645 00	1		AM 4 x 16 DIN 7513 St. Zn
57	501 108 00	2		A 4 x 8 DIN 7603 - Cu
58	051 290 00	1		
59	051 303 00	1		2,5 x 295
60	050 842 01	1		
61	041 618 00	1		

M 15

Reversierstarter
Recoil starter
Demarreur reversible
Arrancador reversible
Avviamento a strappo

Tafel Nr.
Tabl. No.
Tavola N.

12

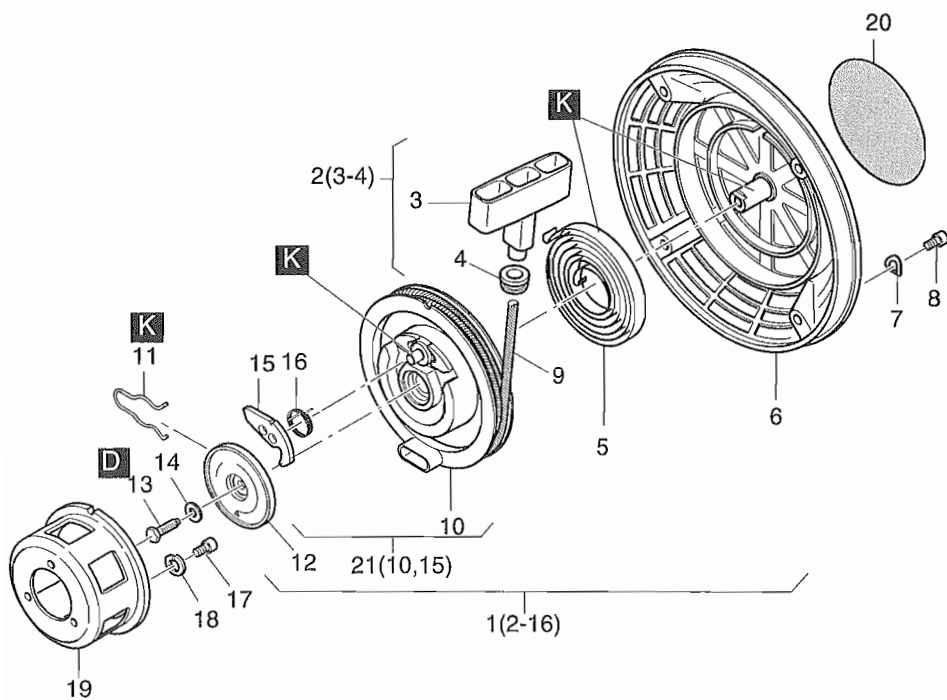

Fig.-No.	HATZ Ident-No.	Stück Qty.	P / W d / D	Bemerkungen Notes
1B20V				
1	015 150 02	1		
2	014 978 00	1		
3	-----	-		
4	036 652 00	1		
5	050 452 01	1		
6	015 693 00	1		
7	500 812 00	4		A 6 DIN 137
8	500 627 00	4		M 6 x 10 DIN 912 - 8.8
9	050 889 01	1		1750 mm
10	-----	-		
11	050 449 01	1		
12	050 450 01	1		
13	501 463 00	1		M 6 x 18 DIN 933 - 8.8 A3C
14	501 656 00	1		6,5 x 14 DIN 6904 - A3C
15	050 448 00	1		
16	050 613 00	1		
17	500 627 00	3		M 6 x 10 DIN 912 - 8.8
18	501 709 00	3		6 DIN 128 - A3C
19	504 458 00	1		
20	051 091 00	1		
21	015 488 00	1		

Luftführung - 1B20
 Air duction - 1B20
 Carter ventilation - 1B20
 Conducción de aire - 1B20
 Carter ventilatore - 1B20

Tafel Nr.
 Tabl. No.
 Tavola N.

M 26

13

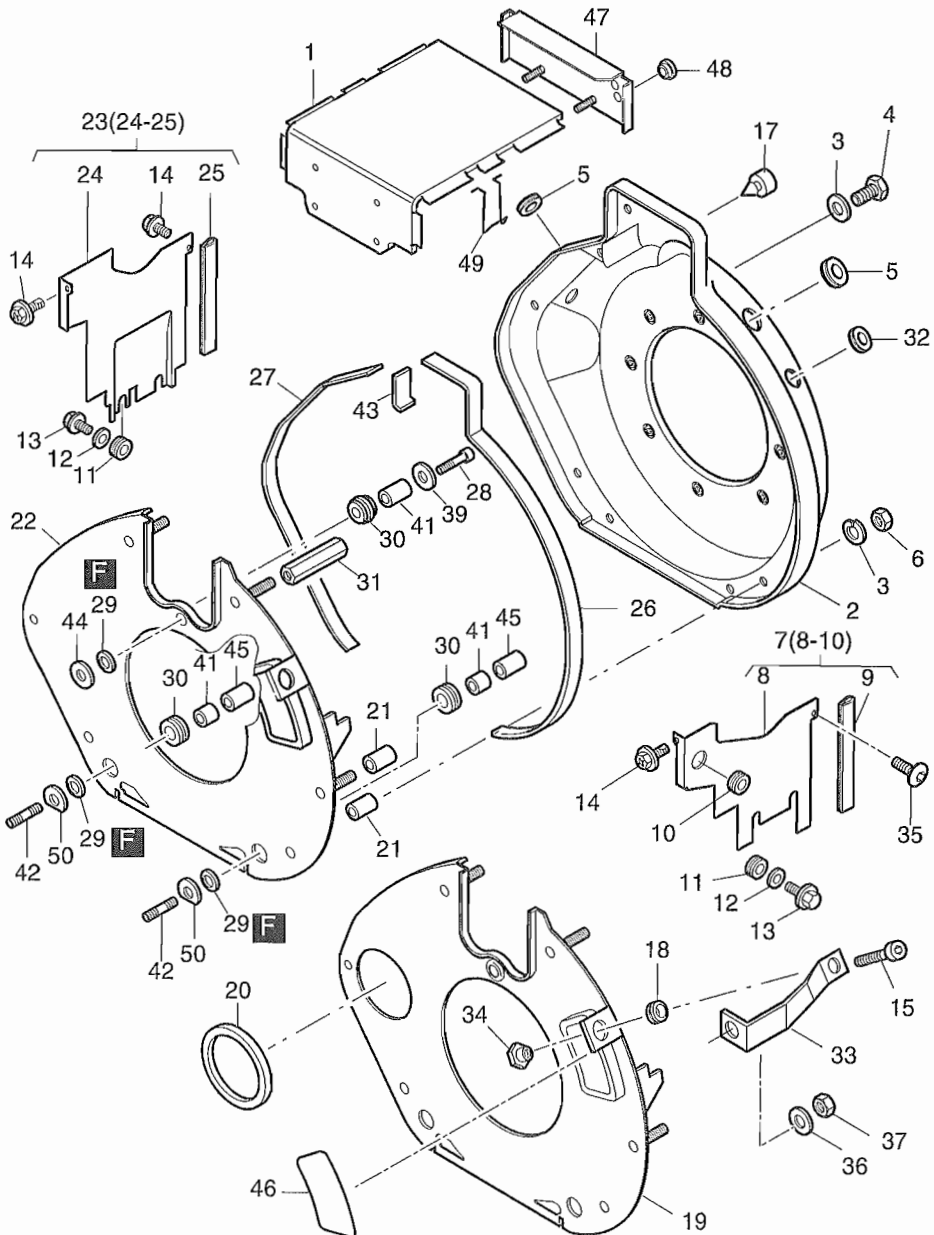

Fig.-No.	HATZ Ident-No.	Stück Qty.	P / W d / D	Bemerkungen Notes
1B20V				
1	015 335 04	1		
2	013 168 00	1		
3	501 709 00	7		6 DIN 128 - A3C
4	501 463 00	1		M 6 x 18 DIN 933 - 8.8 A3C
5	504 617 00	2		
6	501 444 00	6		M 6 DIN 934 - 8 A3C
7	013 166 00	1		
8	-----	-		
9	040 976 00	1		107 mm
10	503 348 00	1		
11	501 638 01	4		
12	504 416 00	3		4,3 DIN 9021 - A3C 140HV
13	504 454 00	3		M 4 x 10 St 8.8 A3A DIN 7500
14	503 356 00	3		M 6 x 16 KZ1 8.8 A3D
15	501 707 00	1		M 6 x 16 DIN 912 - 8.8 A3C
16	-----	-		
17	503 926 10	2		
18	503 928 00	1		
19	016 070 01	1		E-Start
20	040 995 00	1		
21	041 390 00	5		6,5 x 12 x 18
22	016 071 00	1		
23	013 165 00	1		
24	-----	-		
25	040 976 00	1		107 mm
26	041 245 00	1		470 mm
27	041 246 00	1		388 mm
28	501 708 00	1		M 6 x 25 DIN 912 - 8.8 A3C
29	035 755 00	3		
30	009 214 00	3		
31	041 244 00	1		57 mm
32	504 533 00	1		
33	015 995 00	1		
34	041 232 00	1		M 6
35	503 280 00	1		AM 6 x 16 17065 - 8.8
36	500 951 00	1		A 8 DIN 137 A3C

Fig.-No.	HATZ Ident-No.	Stück Qty.	P / W d / D	Bemerkungen Notes
		1B20V		
37	503 447 00	1		M 8 DIN 936 - 5 A3C
38	-----	-		
39	501 709 00	1		6 DIN 128 A3C
40	-----	-		
41	041 191 00	3		6 x 8 x 14
42	504 581 00	2		M 6 x 45 DIN 835 - 8.8 A3C
43	050 073 00	1		48 mm
44	040 420 00	1		6,5 x 22,5 x 1
45	041 390 00	2		6,5 x 12 x 18
46	041 138 00	1		
47	015 793 00	1		
48	503 348 00	2		
49	051 441 00	1		
50	041 453 00	2		

M 31

Kurbelgehäusentlüftung
Crankcase breathing system
Reniflard
Purgador
Sfiato basamento

Tafel Nr.
Tabl. No.
Tavola N.

14

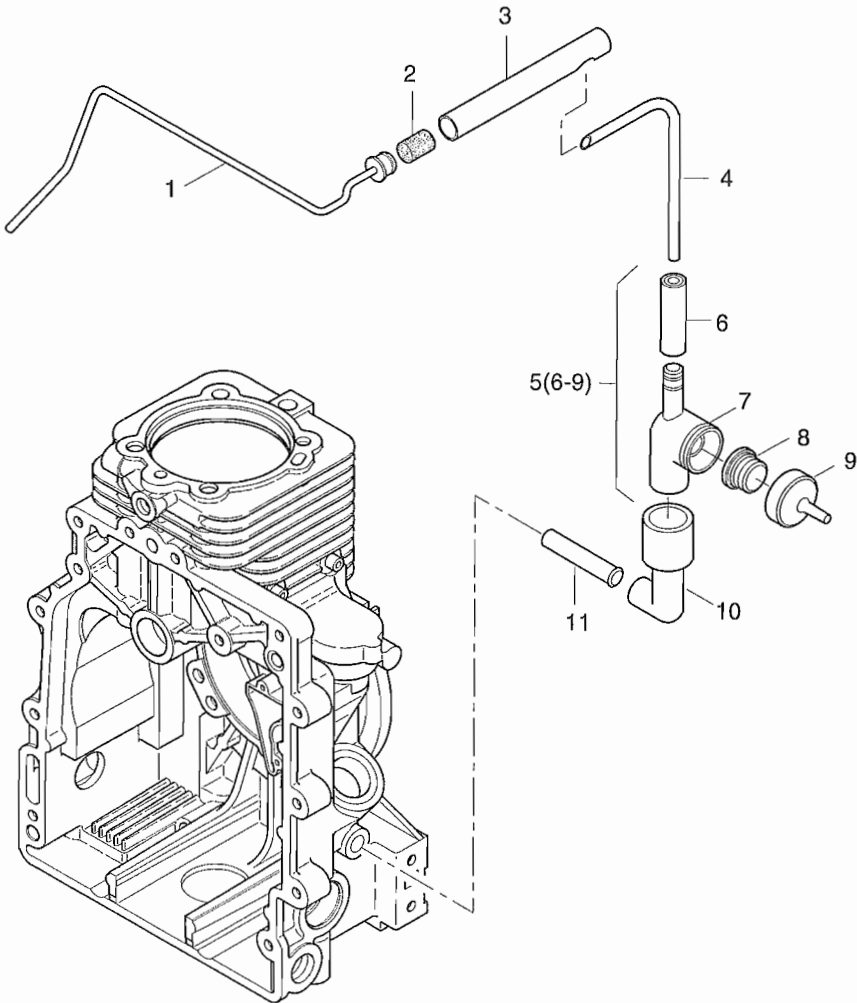

Fig.-No.	HATZ Ident-No.	Stück Qty.	P / W d / D	Bemerkungen Notes
		1B20V		
1	013 391 00	1		
2	051 029 00	1		Filter, Filtre, Filtro
3	041 396 00	1		
4	041 397 00	1		
5	013 396 00	1		
6	013 390 00	1		
7	-----	-		
8	035 687 00	1		
9	035 686 00	1		
10	041 361 00	1		
11	-----	-		

A 01

Kraftstoffbehälter
Fuel tank
Reservoir à carburant
Depósito combustible
Serbatoio

Tafel Nr.
Tabl. No.
Tavola N.

15

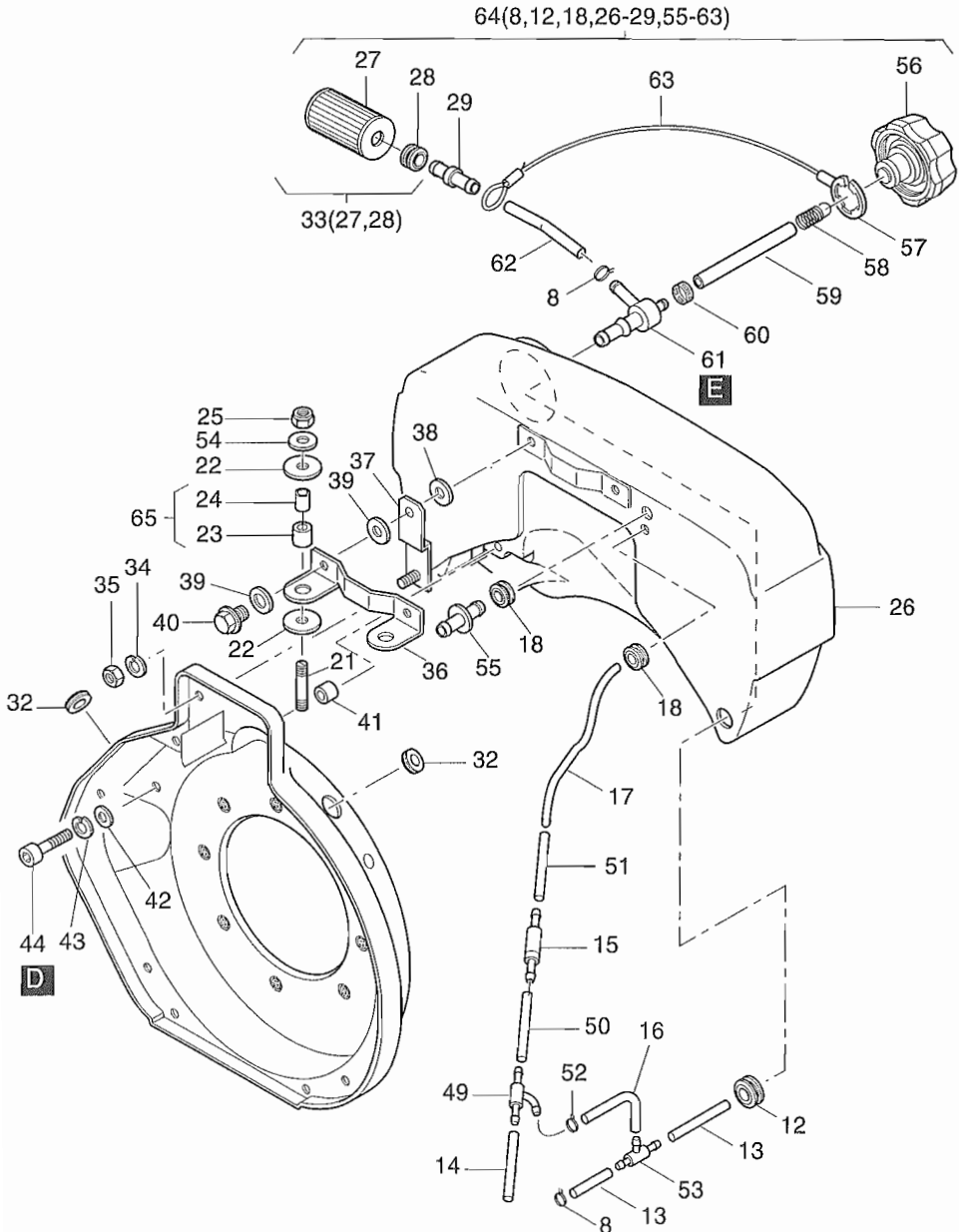

Fig.-No.	HATZ Ident-No.	Stück Qty.	P / W d / D	Bemerkungen Notes
1B20V				
8	504 411 00	2	P1	11,8 - 505 R
12	504 408 00	1		
13	051 231 00	2		7 x 70
14	050 853 00	1		3,5 x 45
15	015 346 00	1		
16	036 733 00	1		4,5 x 170
17	051 576 00	1		
18	051 304 00	2		
21	502 319 00	2		M 8 x 25 DIN 835 - 8.8 A3C
22	051 098 10	4		8,2 x 22 x 2
23	-----	-		
24	051 228 00	2		
25	400 284 00	2		VM 8 DIN 980 - 8 C3A
26	-----	-		
27	-----	-		
28	-----	-		
29	050 844 00	1		
32	051 077 00	2		
33	016 352 00	1	W2	
34	501 709 00	2		6 DIN 128 A3C
35	501 444 00	2		M 6 DIN 934 - 8 A3C
36	051 085 11	1		
37	013 313 00	2		
38	501 200 00	2		A 6,4 DIN 9021 St A3C
39	051 100 10	4		7,1 x 17,9 x 2
40	015 570 00	2		6 x 18
41	041 188 00	2		6,5 x 13 x 4,8
42	501 445 00	2		6,4 DIN 125 St A3C
43	501 709 00	2		6 DIN 128 A3C
44	501 707 00	2		M 6 x 16 DIN 912 - 8.8 A3C
49	051 227 01	1		
50	051 232 00	1		3,5 x 40
51	036 643 00	1		4,5 x 75
52	503 998 01	1		11,3
53	504 596 00	1		
54	501 481 00	2		8,4 DIN 125 St A3C

Fig.-No.	HATZ Ident-No.	Stück Qty.	P / W d / D	Bemerkungen Notes
1B20V				
55	051 296 10	1		
56	016 203 00	1		
57	504 800 00	1		20 x 1 DIN 984
58	504 792 00	1		
59	051 601 00	1		2,5 x 165
60	504 801 00	1		
61	016 239 00	1		
62	050 849 00	1		7 x 190
63	016 289 00	1		≈ 320 mm
64	016 242 00	1		3 l
65	016 558 00	2		

A 02

Luftfilter
Air filter
Filtre à air
Filtro de aire
Filtro aria

Tafel Nr.
Tabl. No.
Tavola N.

16

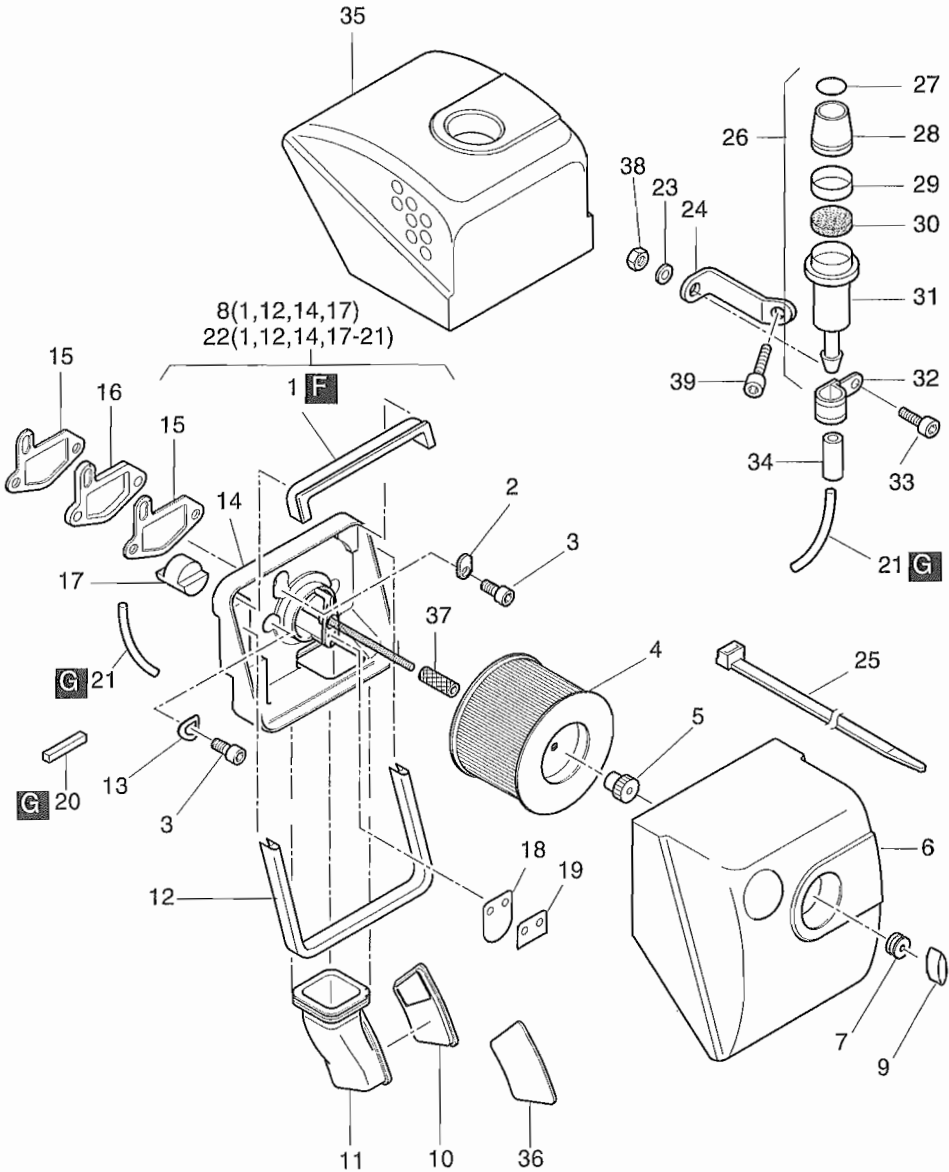

Fig.-No.	HATZ Ident-No.	Stück Qty.	P / W d / D	Bemerkungen Notes
1B20V				
1	050 829 00	1		
2	050 564 00	1		
3	501 715 00	3		M 8 x 25 DIN 912 - 8.8 A3C
4	504 260 00	1	W2	
5	504 543 00	1		
6	050 549 00	1		
7	504 358 00	1		
8	016 293 00	1		
9	504 522 00	1		
10	041 042 00	1		
11	041 030 00	1		
12	040 563 01	1		347 mm
13	500 951 00	2		
14	-----	-		
15	050 563 00	2	d2	
16	016 003 00	1		
17	050 981 00	1		
18	051 471 00	1		(schwarz, black, noir)
19	051 472 00	1		(rot, red, rouge)
20	051 750 00	1		14 x 9 x 30
21	050 446 10	1		2 x 4 x 135
22	016 302 00	1		f. Pos. 26
23	501 709 00	1		6 DIN 128 - A3C
24	051 646 00	1		
25	503 584 00	1		
26	014 998 01	1		(Pos. 27-31)
27	050 445 01	1		
28	050 436 01	1		
29	050 456 00	1		(grün, green, vert, verde)
30	051 372 00	1		Filter, Filtre, Filtro
31	050 437 00	1		
32	501 735 00	1		10/15
33	501 707 00	1		M 6 x 16 DIN 912 - 8.8 A3C
34	039 177 00	1		3,5 x 140
35	051 319 00	1		
36	041 138 00	1		
37	051 662 00	1		32 mm
38	501 444 00	1		M 6 DIN 934 - 8 A3C
39	501 706 00	1		M 6 x 20 DIN 912 - 8.8 A3C

A 03

Abgasdämpfer - 1B20
Exhaust silencer - 1B20
Silencieux - 1B20
Silenciador - 1B20
Marmitta - 1B20

Tafel Nr.
Tabl. No.
Tavola N.

17

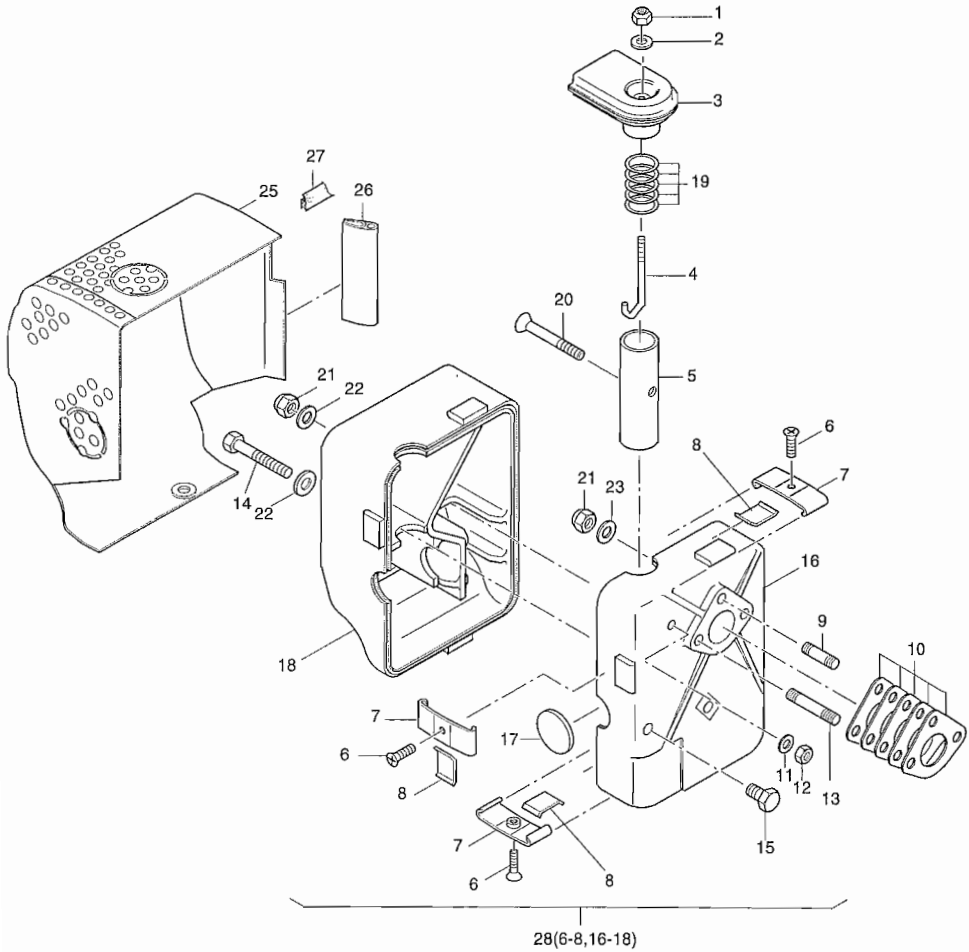

Fig.-No.	HATZ Ident-No.	Stück Qty.	P / W d / D	Bemerkungen Notes
1B20V				
1	400 283 00	1		M6 SSN 440 - 8 - C3P
2	501 445 00	1		6,4 DIN 125 - St A3C
3	015 313 11	1		
4	050 811 01	1		M6
5	050 814 10	1		
6	504 225 00	3		M 6 x 12 DIN 7991 - 8.8 A3C
7	015 312 01	3		
8	050 816 11	3		
9	501 281 00	2		M 8 x 30 DIN 835 - 10.9 A3C
10	050 801 00	5	d5	
11	501 445 00	1		6,4 DIN 125 - St A3C
12	400 283 00	1		M 6 SSN 440-8 C3P
13	500 395 00	1		M 8 x 110 DIN 835 - 8.8 A3C
14	500 288 00	1		M 8 x 90 DIN 931 - 8.8 A3C
15	504 505 00	1		M 8 x 12
16	-----	-		
17	050 810 02	1		
18	-----	-		
19	051 270 00	5		28,1 x 34 x 0,5
20	504 450 00	1		M 6 x 35 DIN 7881 - 8.8 A3C
21	400 284 00	3		DIN 980-8 C3A
22	501 481 00	2		8,4 DIN 125-St. A3C
23	040 543 00	2		8,4 x 21 x 3
24	-----	-		
25	015 323 00	1		
26	051 003 00	1		65 mm
27	051 350 00	1		33 mm
28	015 311 05	1		(Pos. 6 - 8, 16 - 18)

A 05

Starter, Generator
Starter, alternator
Démarrreur, alternateur
Arrancador, alternador
Motorino avviamento, alternatore

Tafel Nr.
Tabl. No.
Tavola N.

18

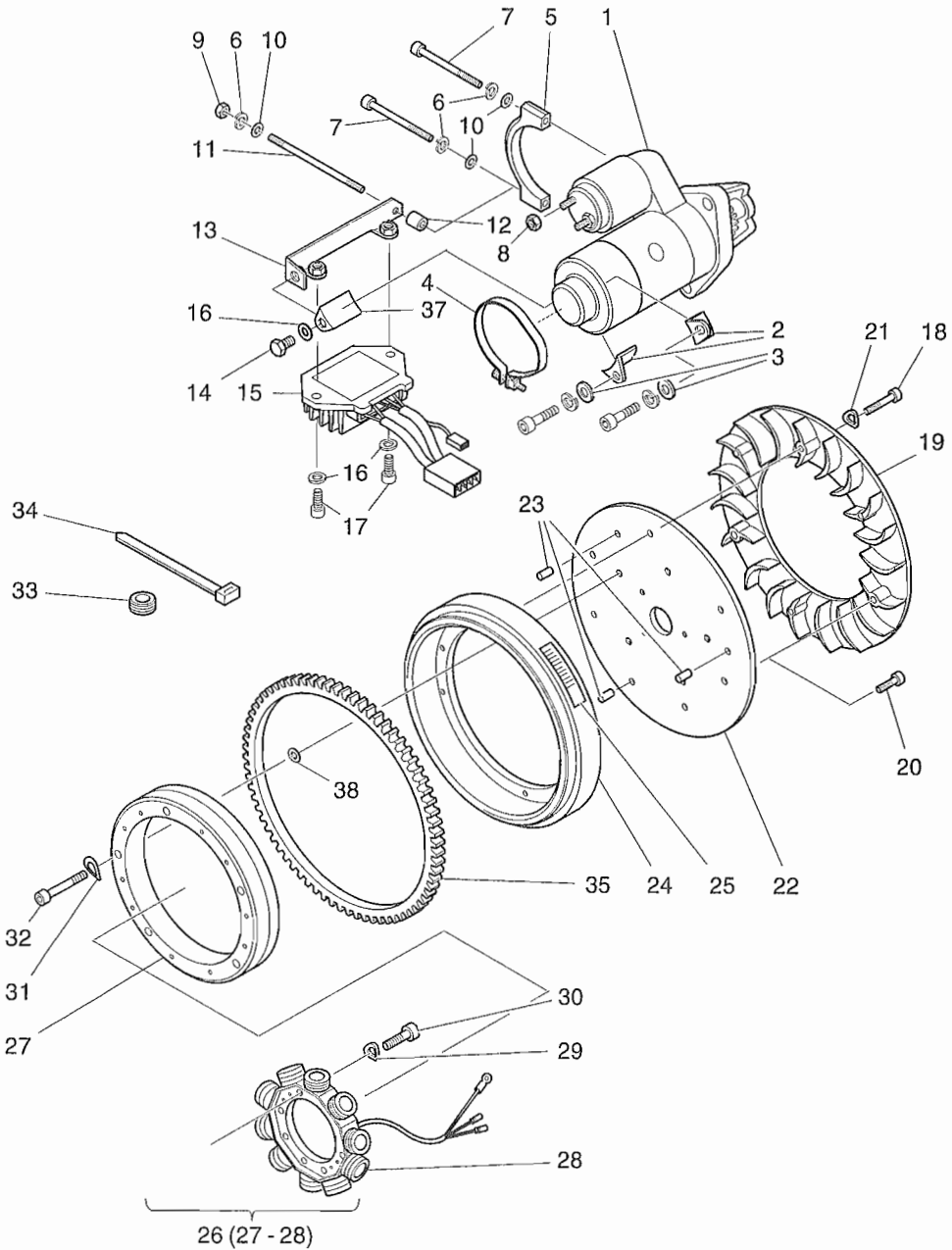

Fig.-No.	HATZ Ident-No.	Stück Qty.	P / W d / D	Bemerkungen Notes
1B20V				
1	504 262 01	1		12 V
2	041 384 00	2		
3	501 481 00	2		8,4 DIN 125 - St A3C
4	041 156 00	1		
5	040 991 00	1		
6	501 709 00	2		6 DIN 128 - A3C
7	504 443 00	2		M 6 x 80 DIN 912 - 8.8 A3C
8	500 232 00	1		BM8 DIN 439 - 5 A3C
9	501 444 00	1		M 6 DIN 934 - 8 A3C
10	501 445 00	2		6,4 DIN 125 - St A3C
11	504 559 00	1		MFS 6 x 90 DIN 949 - 1 8.8 A3C
12	036 714 00	1		7 x 12 x 15
13	015 609 00	1		
14	500 962 00	1		M 8 x 12 DIN 933 - 8.8 A3C
15	051 007 01	1		12 V
16	501 481 00	3		8,4 DIN 125 - St A3C
17	501 654 00	2		M 8 x 16 DIN 912 - 8.8 A3C
18	503 273 00	6		M 4 x 20 DIN 912 - 8.8 A3C
19	013 213 10	1		
20	504 168 00	3		M 6 x 16 DIN 912 - 8.8 A3C Tuf.
21	500 034 00	6		A 4 DIN 137 - St
22	040 987 20	1		
23	500 352 00	3		6 x 12 DIN 1481 55 Si 7
24	040 982 20	1		
25	041 172 00	1		„E-Start“ OT
26	504 359 01	1		12 V
27	-----	-		
28	-----	-		
29	500 819 00	4		A 5 DIN 137 A3C
30	504 271 00	4		M 5 x 25 DIN 912 - 8.8 A3C
31	500 812 00	5		A 6 DIN 137 A3C
32	504 487 00	5		M 6 x 30 DIN 6912 - 8.8 A3C
33	035 654 00	1		
34	503 584 00	3		
35	040 986 00	1		
37	041 384 00	1		
38	501 143 00	5		6,4 DIN 7349 - A3C

A 05
A 10

Armaturen, Leitungen
Electric equipment, wirings
Équipement électrique, cable
Equipo eléctrico, cables
Equipaggiamento elettrico, cablaggio

Tafel Nr.
Tabl. No.
Tavola N.

19

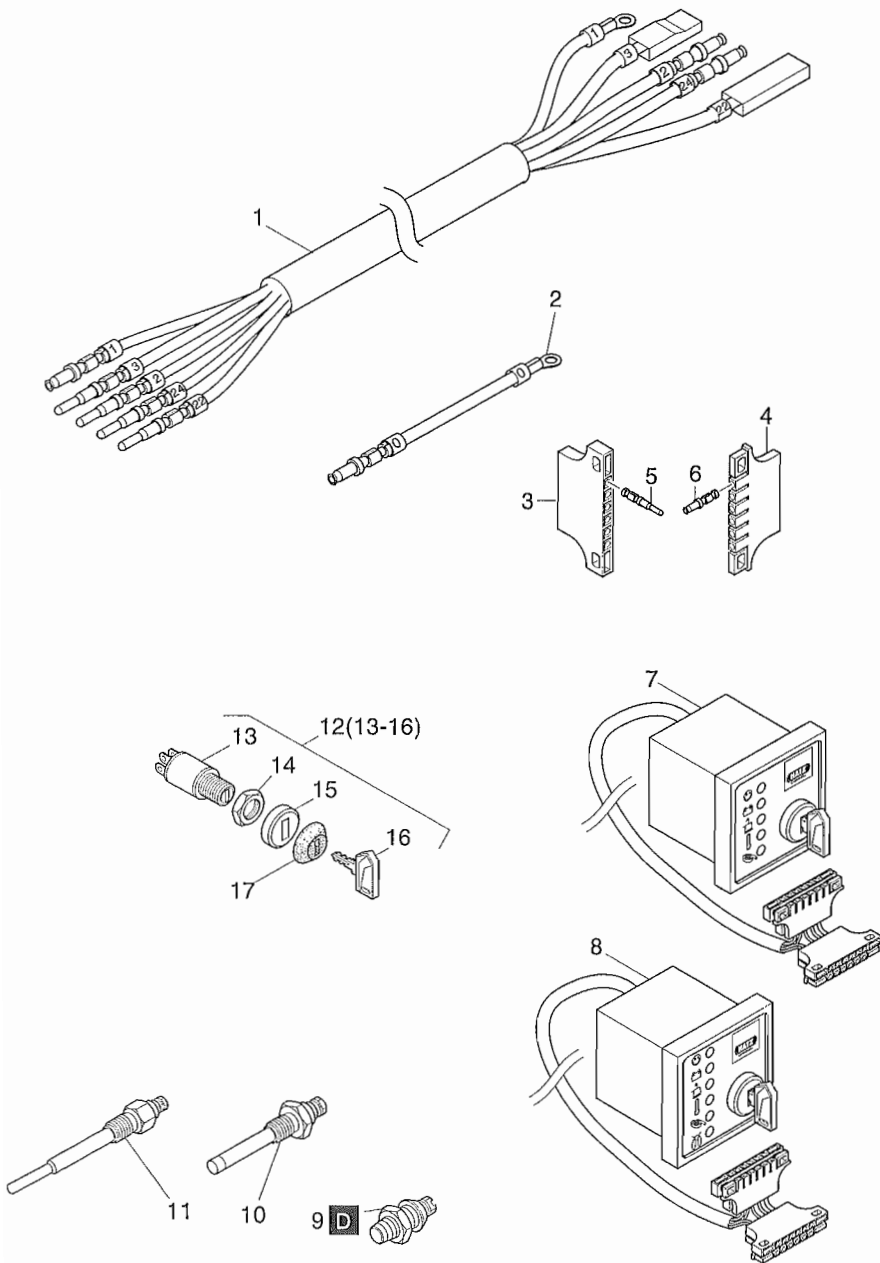

Fig.-No.	HATZ Ident-No.	Stück Qty.	P / W d / D	Bemerkungen Notes
1B20V				
1	015 422 00	1		
2	015 483 00	1		
3	503 736 00	1		
4	503 737 00	1		
5	503 741 00	5		0,5 - 1,0
6	503 739 00	6		1,5 - 2,5
7	015 518 02	1		12 V
8	015 589 01	1		12 - 24 V Aut.
9	400 213 00	1		Oil
10	502 686 00	1		Temp.
11	504 492 00	1		12 V
12	503 844 01	1		
13	-----	-		
14	-----	-		
15	-----	-		Oil
16	504 049 00	1		Nr. 14644
17	051 264 02	1		

A 90

Motorausrüstung EPA
Spec. equipment EPA
Equipm. spec. EPA
Equipo espec. EPA
Kit trasformazione EPA

Tafel Nr.
Tabl. No.
Tavola N.

20

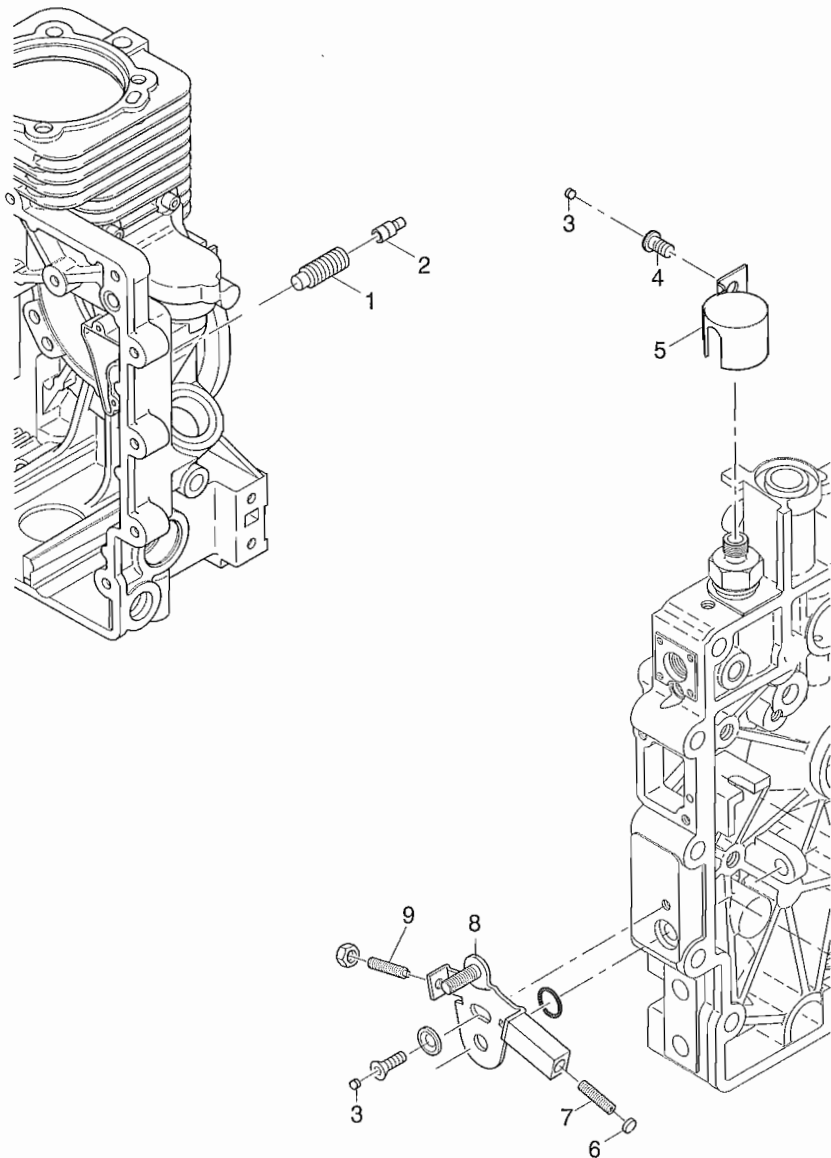

Fig.-No.	HATZ Ident-No.	Stück Qty.	P / W d / D	Bemerkungen Notes
1B20V				
1	041 506 00	1		
2	041 505 00	1		6
3	041 706 00	2		4,3
4	504 950 00	1		M 6 x 12 DIN 7380-10.9 A3C
5	013 536 00	1		
6	504 760 00	1		8 DIN 470-Al
7	505 070 00	1		M 6 x 30 DIN 915
8	013 561 00	1		
9	505 071 00	1		M 6 x 25 DIN 915

Serien-Nr.-Änderungen
Serial-code modification list
Modification des Nos de serien
Modificación de los Nos de serie
Modifica dei codici

IMT-No.

1 B 20 V.10	1 B 20 V.11	98.580
1 B 20 V.11	1 B 20 V.12	00.590
1 B 20 V.12	1 B 20 V.13	00.595