

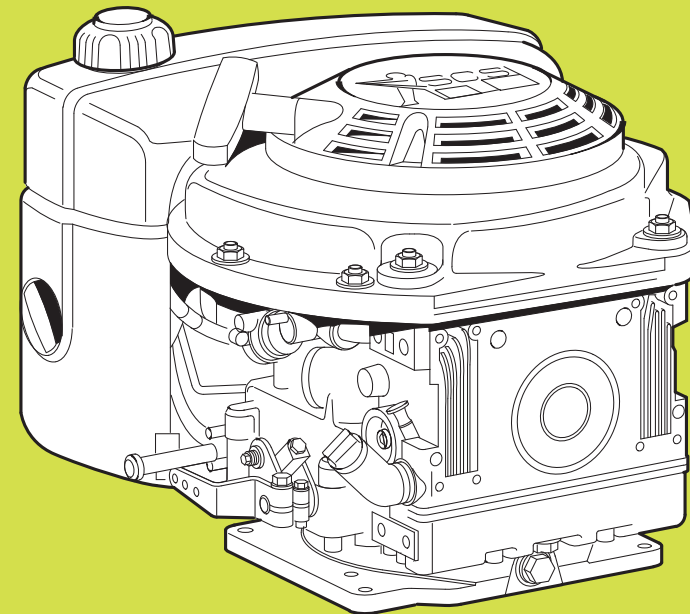

MOTORENFABRIK **HATZ** GMBH & CO KG
Ernst-Hatz-Straße 16 • 94099 Ruhstorf • Germany
Tel.: +49 (0) 85 31 / 319-0 • Telefax: +49 (0) 85 31 / 31 94 18
eMail: marketing@hatz-diesel.de • www.hatz-diesel.com

Original-Ersatzteile

Original-spare parts
Pièces de rechange d'origine
Repuestos originales
Pezzi di ricambio originali



1 B 20 V
1 B 30 V

0000 434 800 82
09.10- 0.2
Printed in Germany



Original-Ersatzteile

Original-spare parts
Pièces de rechange d'origine
Repuestos originales

① TYPE / SPEC. / FDT
② SERIAL NO.
③ MIN ⁻¹

+ EMISSION CONTROL INFORMATION +	
MOTORENFABRIK HATZ KG · D-94099 RÜHSTORF	
ENG.FAM.	MADE IN GERMANY
TYPE / SPEC. / FDT	
①	
SERIAL NO.	Liter / PV
②	
MIN ⁻¹	NH / KW
③	BUILD DATE
This engine conforms to LM U.S. EPA regulations large nominal compression-ignition engines and MY California regulation for off-road compression-ignition engines. Refer to Owner's manual for maintenance specifications and adjustments.	
EC-TYPE NO.	
+ CONSTANT-SPEED ONLY VARIABLE SPEED +	

Nächste HATZ-Servicestelle:

Nearest HATZ service station:

Station-service HATZ la plus proche:

Servicio HATZ más cercano:

Più vicino centro di servizio HATZ:

www.hatz-diesel.com

Ersatzteilliste Nr./ Spare parts list no./ Liste des pièces de rechange no./ Lista de repuestos No./ Lista ricambi n.

1 B 20V.22 □ (111 22)
1 B 30V.18 EPA IV □ (112 18)

Beispiel: / Example: / Exemple: / Ejemplo: / Esempio: **111 22 11 123456**

Engine type No. | Engine series | Prod. year | Consecutively number

Lassen Sie Service-Arbeiten immer von qualifiziertem Fachpersonal durchführen. Wir empfehlen Ihnen hierfür eine von über 500 **HATZ-Servicestationen**. Dort wird Ihr Motor von laufend geschultem Personal, mit **Original HATZ-Ersatzteilen** und mit **HATZ-Werkzeug** instandgesetzt.

Der Einbau von ungeeigneten Ersatzteilen kann zu Problemen führen. Für Schäden oder Folgeschäden, die daraus entstehen, können wir keine Haftung übernehmen. Wir empfehlen deshalb die Verwendung von **Original HATZ-Ersatzteilen**. Diese Teile sind nach den strengen **HATZ-Spezifikationen** gefertigt und sorgen durch ihre perfekte Passform und Funktion für höchste Betriebssicherheit.

Always have service work performed by qualified specialists. To this effect, we recommend that you consult one of the 500 **HATZ service stations**. There, your engine is repaired by staff who constantly undergo training and who use both **original HATZ spare parts** and **HATZ tools**. The installation of inappropriate spare parts may cause problems. We cannot accept any liability for damage or consequential damage resulting therefrom. Thus, we recommend that you use **original HATZ spare parts**. These parts are manufactured following the strict **HATZ specifications** and ensure, thanks to their perfect fit and function, maximum operating reliability.

Toujours faire effectuer les travaux de service après-vente par un personnel qualifié. Nous vous conseillons de contacter un des 500 **ateliers agréés HATZ**. Votre moteur y sera réparé par un personnel formé régulièrement et utilisant des **pièces de rechange d'origine HATZ** et **l'outillage HATZ**. Le montage de pièces de rechange adaptables peut entraîner des problèmes. Nous n'assumons aucune responsabilité pour des dommages directs ou indirects qui en découlent. Pour cette raison, nous vous recommandons l'utilisation des **pièces de rechange d'origine HATZ**. Ces pièces sont usinées selon les spécifications sévères **HATZ** et grâce à l'adaptation et le fonctionnement parfaits elles garantissent un maximum de sécurité de fonctionnement.

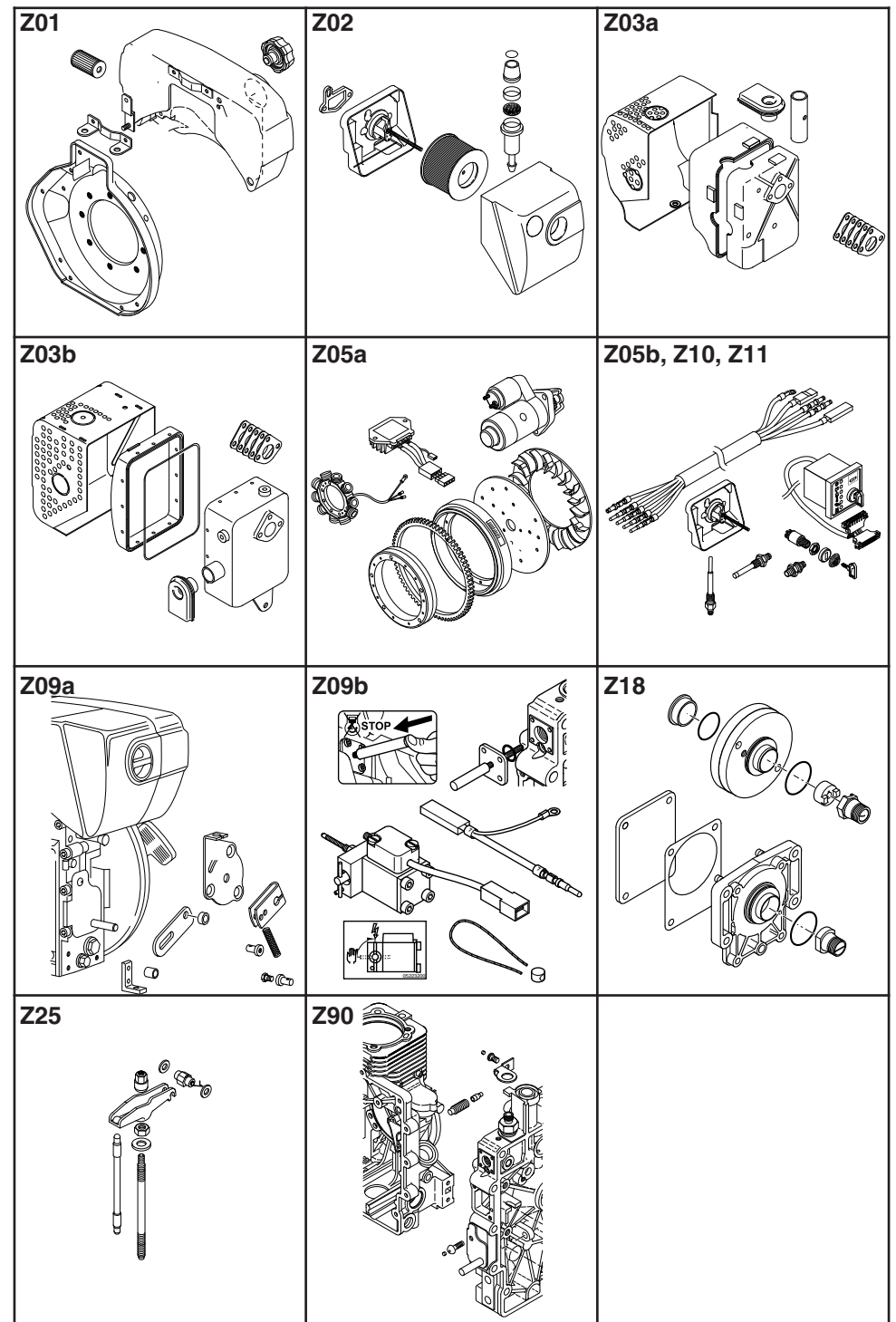
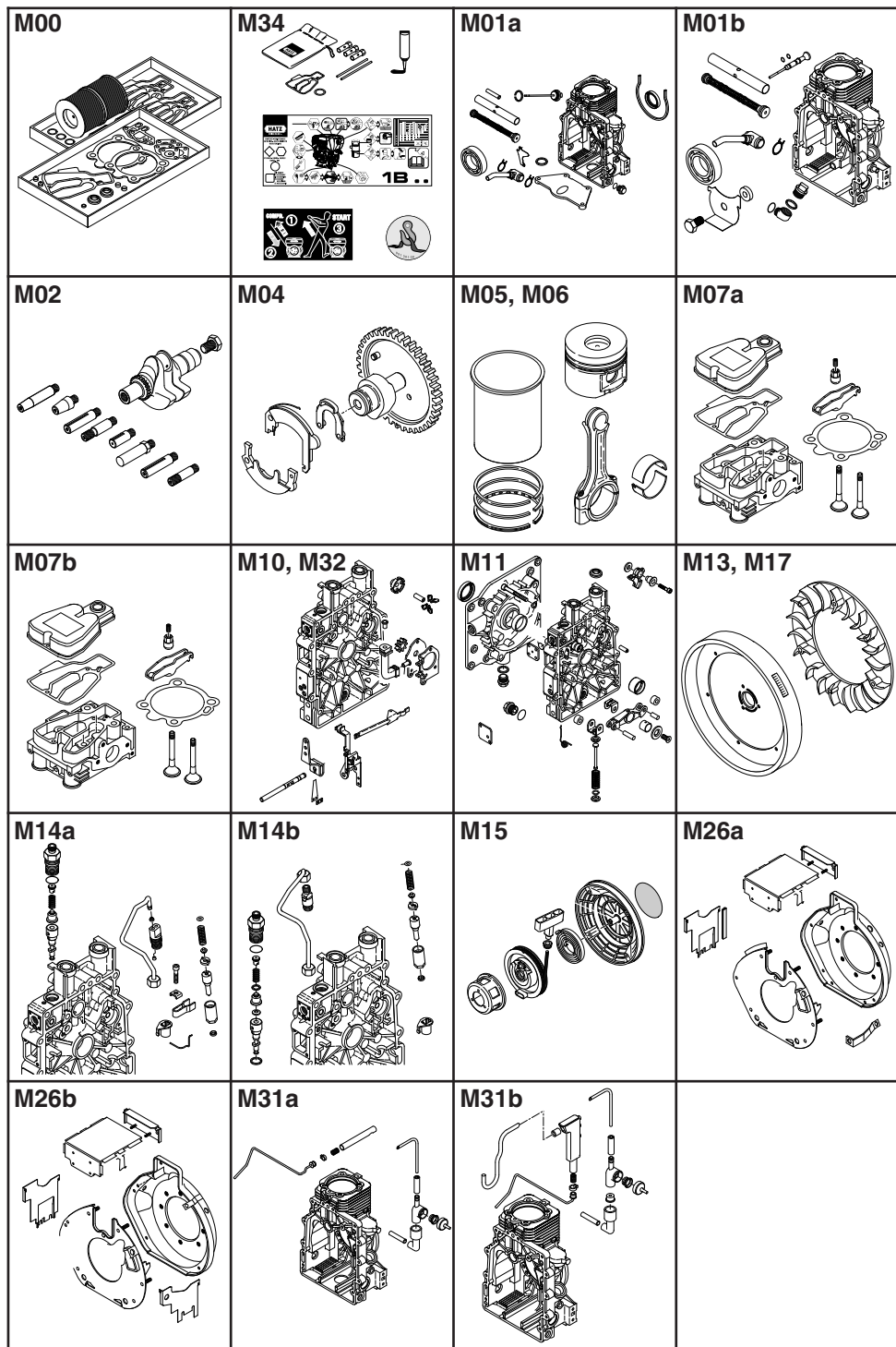

Ersatzteilsätze
Spare parts kits
Jeux de pièces de rechange
Juegos de piezas de recambios
Serie guarnizioni

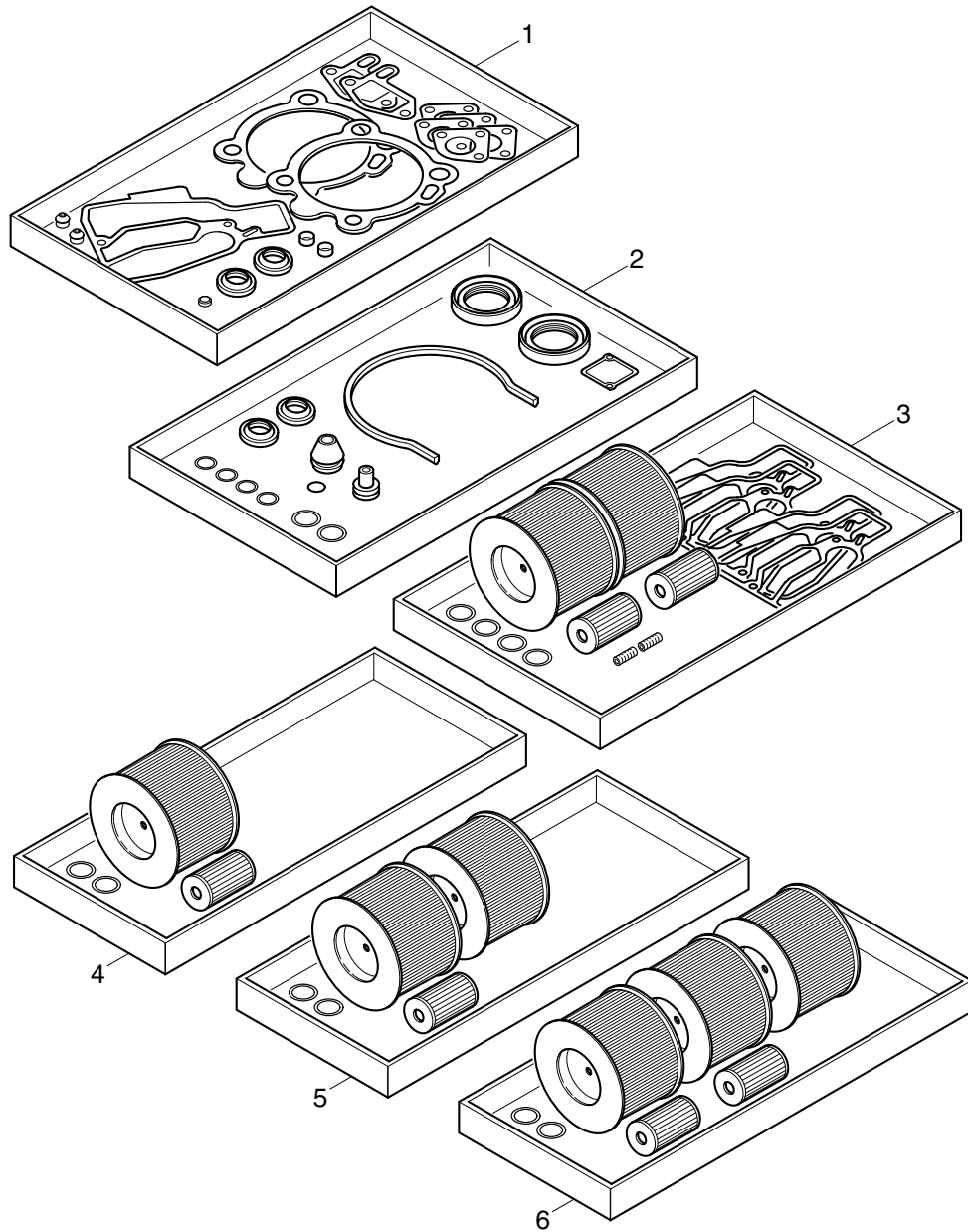

Fig.- No.	HATZ Ident-No.	Stück Qty.	1B20V	1B30V EPA IV	W d / D	Bemerkungen Notes
W:						Im Wartungssatz enthalten. Incl. in maintenance kit. Contenu dans le jeu d'entretien. Incluido en el juego de mantenimiento. Contenuto nella serie manutenzione.
D:						Im Dichtungssatz Kurbelgeh. Incl. in gasket set crankcase. Contenu dans le jeu de joints carter moteur. Incluido en el juego de juntas caja cigueñal. Contenuto nella serie guarnizioni basamento.
d:						Im Dichtungssatz f. 1 Zyl.-Kopf enthalten. Incl. in gasket set f. 1 cyl. head. Contenu dans le jeu de joint p. 1 culasse. Incluido en el juego de juntas p. 1 culata. Contenuto nella serie guarnizioni p. 1 testa.
1:						Anzahl pro Satz - Qty. per kit Quantite p. jeu - Cantidad p. juego Quantità per serie
1	0000 015 541 01	1	-	-		Dichtungssatz für 1 Zylinderkopf
1	0000 015 822 10	-	1	1		Gasket set for 1 cyl. head
						Jeu de joint p. 1 culasse
						Juego de juntas para 1 culata
						Serie guarnizioni per 1 testa
2	0000 017 095 04	1	-	-		Dichtungssatz für Kurbelgehäuse
2	0000 017 097 03	-	1	1		Gasket set for crankcase
						Jeu de joints p. carter moteur
						Juego de juntas para caja cigueñal
						Serie guarnizioni basamento
3	0000 017 096 00	1	-	-		Wartungssatz für 1000 h
3	0000 017 098 00	-	1	1		1000 hours maintenance kit
						Kit d'entretien 1000 heures -
						Juego de piezas para servicio 1C 1000 horas
						Kit di manutenzione a 1000 ore
4	0000 022 654 00	1	1	1		Filterprogramm
5	0000 022 679 00	1	1	1		Filter program
6	0000 022 690 00	1	1	1		Progr. de filtr.
						Progr. de filtros
						Programma di filtro

M34

Zubehör
Accessories
Accessoires
Accessorios
Kit accessori

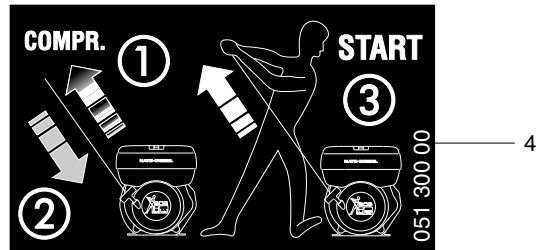
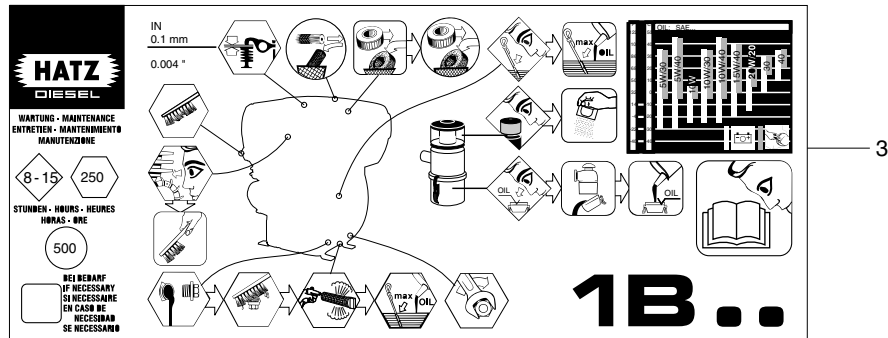
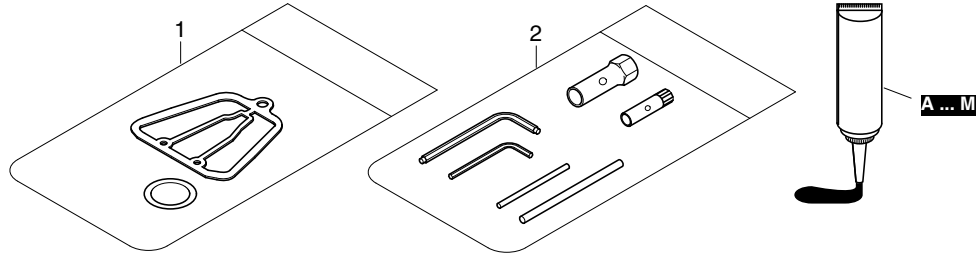

Fig.- No.	HATZ Ident-No.	Stück Qty.		W d / D	Bemerkungen Notes
		1B20V	1B30V EPA IV		
1	0000 013 310 02	1	-		Zubehörsatz - Accessoires kit
1	0000 015 787 01	-	1		Zubehörsatz - Accessoires kit
2	0000 013 309 01	1	1		Werkzeugsatz - Tool set
3	0000 051 104 05	1	1		160 x 67mm
4	0000 051 300 00	1	1		

Dicht- und Klebstoffe Materias para empaquetar y pegar
Sealing- and bonding adhesives Adesivi e collanti
Etanchéifiant et Colle

A =	0000 502 230 01	Loctite Activator N	500 ml	} siehe Hinweis auf den einzelnen Bildtafeln as specified in the individual tables suivant les remarques sur les tableau correspondant según las indicaciones de las tablas correspondientes seguire le indicazioni sul quadro corrispondente
B =	0000 502 231 01	Loctite 574	50 ml	
C =	0000 502 232 00	Loctite 601	50 ml	
D =	0000 502 233 00	Loctite 221	50 ml	
E =	0000 502 234 00	Loctite 648	10 ml	
F =	0000 502 238 00	Technicoll 8058	0,75 kg	
	+ 0000 502 239 00	Technicoll 8367	0,75 kg	
G =	0000 502 565 01	Loctite IS 407	20 g	
H =	0000 700 189 44	Silicon	310 ml	
J =	0000 502 830 04	Hochtemp. Paste	100 ml	
K =	0000 503 426 01	Hochtemp. Fett	400 g	
L =	0000 502 566 00	Silicon sealer	100 g	
M =	0000 504 851 00	Schleifpaste	80 g	

M01a

Kurbelgehäuse - 1B20V
 Crankcase - 1B20V
 Carter moteur - 1B20V
 Caja cigueñal - 1B20V
 Basamento motore - 1B20V

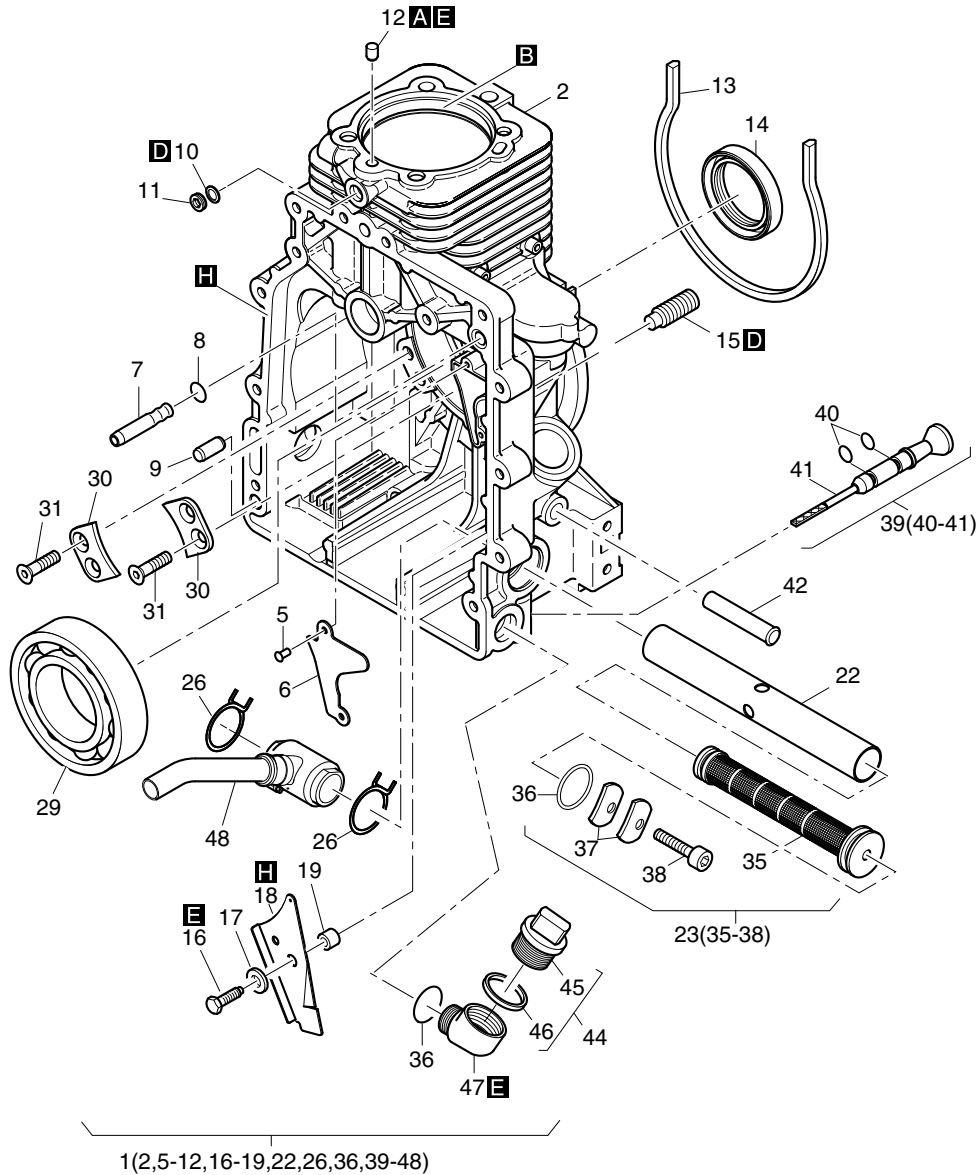

Fig.- No.	HATZ Ident-No.	Stück Qty.	W d / D	Bemerkungen Notes
		1B20V		
1	0000 016 250 21	1		
2	-----	-		
5	0000 400 026 00	2		3,2
6	0000 041 054 00	1		
7	0000 050 843 00	1		
8	0000 504 403 00	1		D1 8 x 1,5
9	0000 502 491 02	1		8 M 6 x 20 2-Fasen
10	0000 500 624 00	1		A 10 x 13,5 DIN 7603-Cu
11	0000 500 623 00	1		M 10 x 1 DIN 908-5.8 A3C
12	-----	-		
13	0000 040 980 00	1		D1 318 mm
14	0000 504 232 00	1		D1 40 x 55 x 10 AS
15	0000 041 506 00	1		
16	0000 502 079 00	1		M 6 x 20 DIN 933-8.8 A3C
17	0000 501 445 00	1		6,4 DIN 125-St A3C
18	0000 042 224 01	1		
19	0000 042 295 00	1		6,5 x 13 x 9,5
22	0000 041 057 10	1		
23	0000 015 427 03	1		
26	0000 050 369 00	2		
29	0000 504 233 00	1		
30	0000 040 944 00	2		
31	0000 505 643 00	4		M 6 x 16 8.8 MK PRE 80-8
35	-----	-		
36	0000 504 759 01	2		D2 20 x 4
37	0000 051 482 00	2		
38	0000 501 707 00	1		M 6 x 16 DIN 912-8.8 A3C
39	0000 013 505 02	1		
40	0000 400 220 00	2		D2 5 x 2
41	-----	-		
42	-----	-		
44	0000 016 131 00	1		
45	-----	-		
46	0000 041 250 00	1		26 x 35 x3
47	0000 041 637 00	1		
48	0000 013 398 00	1		

M01b

Kurbelgehäuse - 1B30V
 Crankcase - 1B30V
 Carter moteur - 1B30V
 Caja cigueñal - 1B30V
 Basamento motore - 1B30V

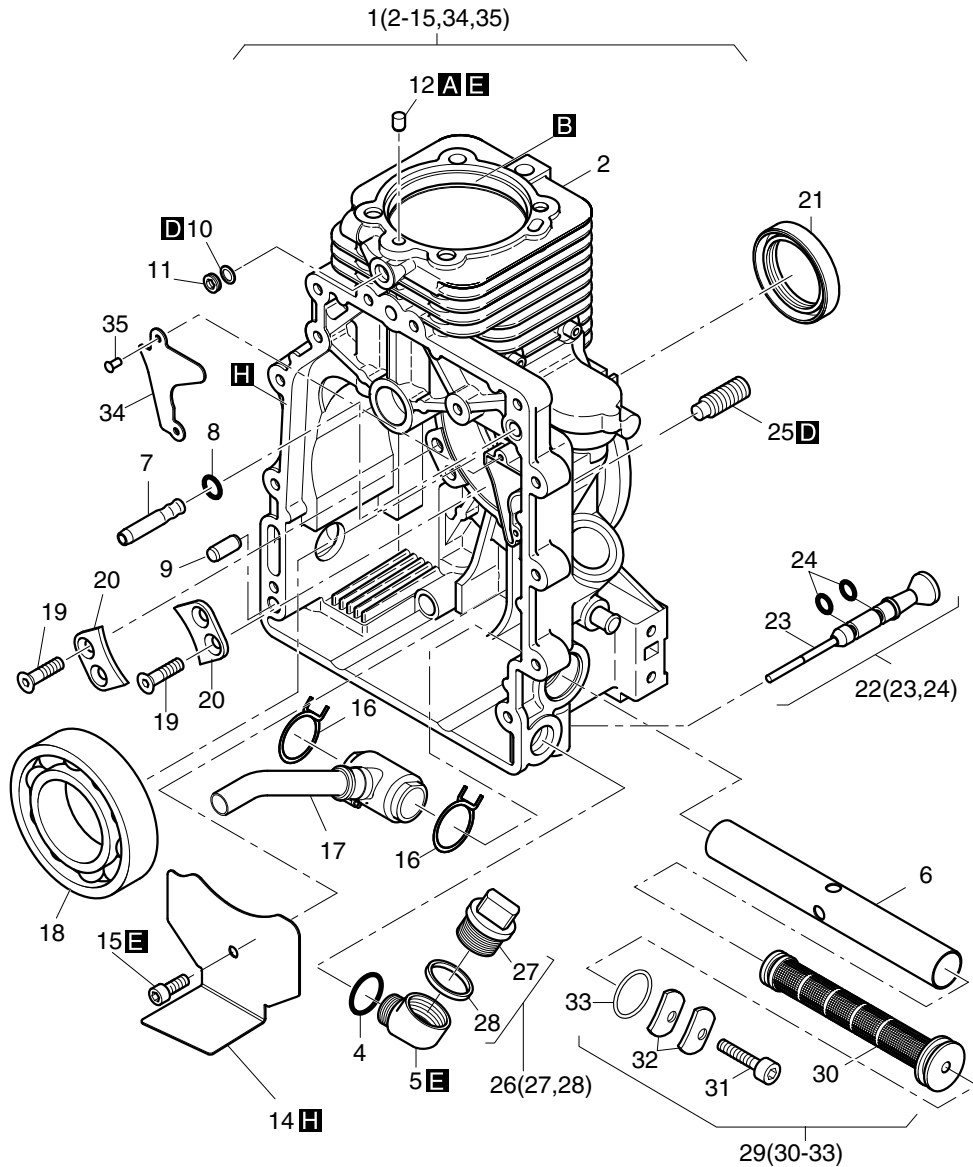

Fig.- No.	HATZ Ident-No.	Stück Qty.	W d / D	Bemerkungen Notes
		1B30V EPA IV		
1	0000 017 063 10	1		
2	-----	-		
4	0000 504 759 01	1		D1 20 x 4
5	0000 041 637 00	1		
6	0000 041 057 10	1		
7	0000 050 843 00	1		
8	0000 504 403 00	1		D1 8 x 1,5
9	0000 502 491 02	1		8 M 6 x 20 2-Fasen
10	0000 500 624 00	1		A 10 x 13,5 DIN 7603-Cu
11	0000 500 623 00	1		M 10 x 1 DIN 908-5.8 A3C
12	-----	-		
14	0000 041 656 10	1		
15	0000 501 491 00	1		M 6 x 12 DIN 912-8.8 A3C
16	0000 050 369 00	2		
17	0000 013 398 00	1		
18	0000 504 497 00	1		
19	0000 505 643 00	4		M 6 x 16 8.8 MK PRE 80-8
20	0000 040 944 00	2		
21	0000 504 498 00	1		D1 42 x 55 x 10 AS
22	0000 013 505 02	1		
23	-----	-		
24	0000 400 220 00	2		D1 5 x 2
25	0000 041 506 00	1		
26	0000 016 131 00	1		
27	-----	-		
28	0000 041 250 00	1		D1 26 x 35 x3
29	0000 015 427 03	1		
30	-----	-		
31	0000 501 707 00	1		M 6 x 16 DIN 912-8.8 A3C
32	0000 051 482 00	2		
33	0000 504 759 01	1		D1 20 x 4
34	0000 013 331 11	1		
35	0000 400 026 00	2		3,2

M02

Kurbelwelle
Crankshaft
Vilebrequin
Cigueñal
Albero a gomito

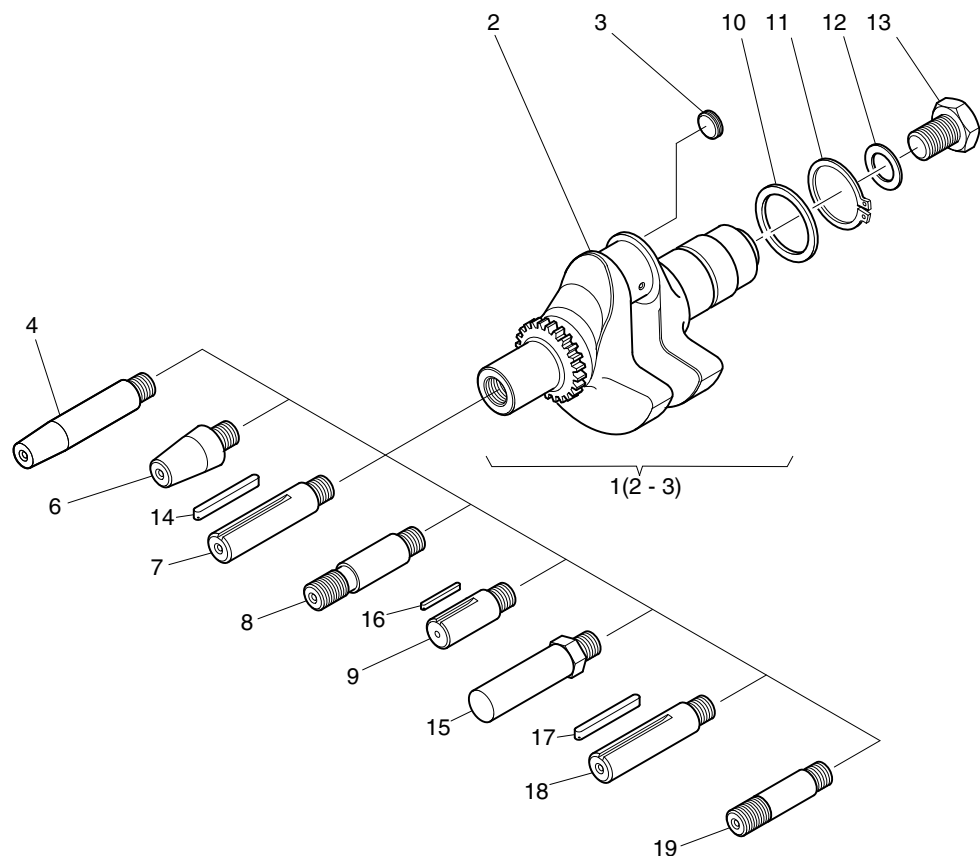

Fig.- No.	HATZ Ident-No.	Stück Qty.		W d / D	Bemerkungen Notes
		1B20V	1B30V EPA IV		
1	0000 013 403 10	1	-		
1	0000 013 612 01	-	1		1B30V "X"
2	-----	-	-		
3	0000 503 008 01	1	1		
4	0000 050 996 00	1	-		Nr. 4 SAE Generator ø 19,8 mm
4	0000 051 274 01	-	1		Nr. 4 SAE Generator ø 7/8"
6	0000 050 997 00	1	1		Nr. 6 ital. 23 keg., con.
6	0000 051 427 00	-	1		keg., con. ø 25 f. Gen.
7	0000 050 998 00	1	-		Nr. 7 - ø 3/4" zyl., cil.
7	0000 051 276 20	-	1		Nr. 2 - ø 1" zyl., cil.
8	0000 050 999 00	1	-		Nr. 8 SAE 3/4" - 16 UNF 2A
8	0000 051 277 22	-	1		Nr. 1 - SAE ø 1" - 14 UNS 2A
9	0000 051 000 00	1	-		ø 20 zyl., cil.
9	0000 051 278 01	-	1		ø 25 zyl., cil.
10	0000 400 325 00	1	-		40 x 50 x 2,5 DIN 988
10	0000 400 656 00	-	1		45 x 55 x 3,0
11	0000 501 206 00	1	-		A 40 x 1,75 DIN 471
11	0000 500 216 00	-	1		A 45 x 1,75 DIN 471
12	0000 041 142 01	1	1		18,5 x 37 x 5
13	0000 504 436 00	1	1		M 18 x 1,5 x 55 DIN 961 - 10.9
14	0000 041 204 00	1	-		4,75 x 30
14	0000 051 416 00	-	1		A 6,35 x 61
15	0000 051 073 02	1	1		SW 27 mm, ø 26,8 mm
16	0000 504 634 00	1	-		A 5 x 5 x 36 DIN 6885
16	0000 504 737 00	-	1		7 x 8 x 45 DIN 6885
17	0000 504 634 00	1	1		A 5 x 5 x 36 DIN 6885
18	0000 041 525 00	1	1		ø 22,2 zyl., cil.
19	0000 052 322 20	1	1		

M04

Nockenwelle
Camshaft
Arbre à cames
Arbol de levas
Albero a camme

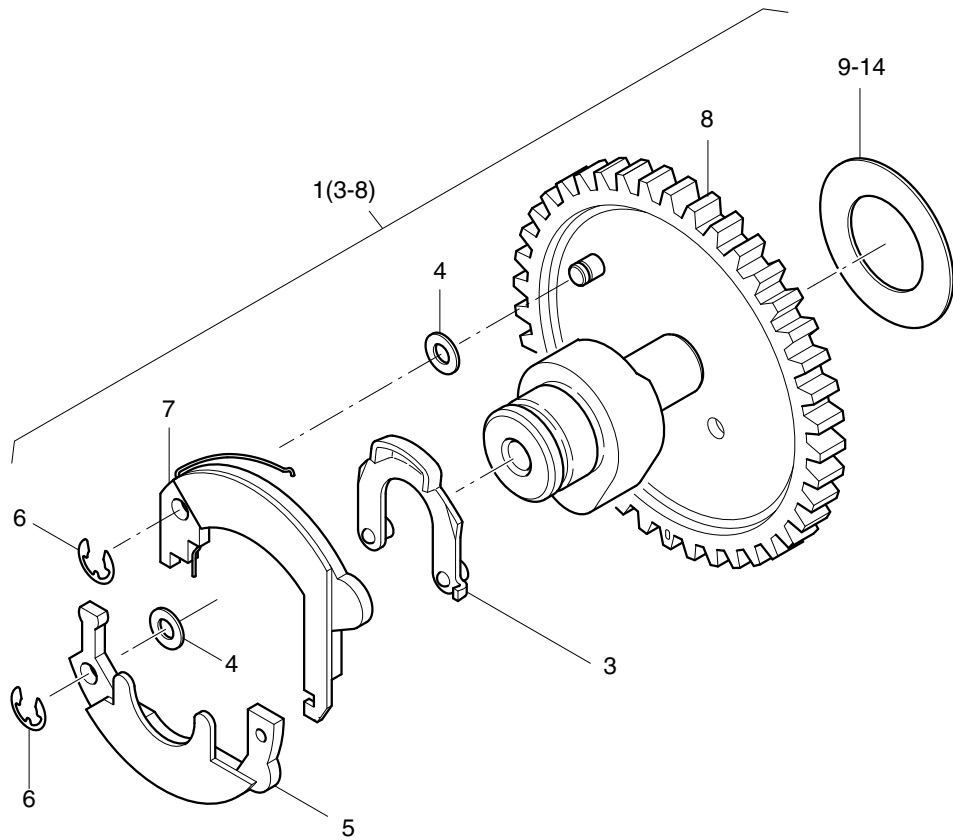

Fig.- No.	HATZ Ident-No.	Stück Qty.		W d / D	Bemerkungen Notes
		1B20V	1B30V EPA IV		
1	0000 013 650 02	1	1		
3	0000 013 264 01	1	1		
4	0000 501 232 00	2	2		5 x 10 x 0,5 DIN 988
5	0000 013 266 00	1	1		
6	0000 502 553 00	2	2		3,2 DIN 6799
7	0000 013 649 00	1	1		
8	-----	-	-		
9	0000 041 217 00	0... 1	0... 1		0,9 mm 23 x 38 x 0,9
10	0000 041 121 00	0... 1	0... 1		1,0 mm 23 x 38 x 1,0
11	0000 041 122 00	0... 1	0... 1		1,1 mm 23 x 38 x 1,1
12	0000 041 123 00	0... 1	0... 1		1,2 mm 23 x 38 x 1,2
13	0000 041 251 00	0... 1	0... 1		1,3 mm 23 x 38 x 1,3
14	0000 041 252 00	0... 1	0... 1		1,4 mm 23 x 38 x 1,4

M05, M06

Kolben, Pleuel, Zylinder
 Piston, conrod, cylinder
 Piston, bielle, cylindre
 Embolo, biela, cilindro
 Pistone, biella, cilindro

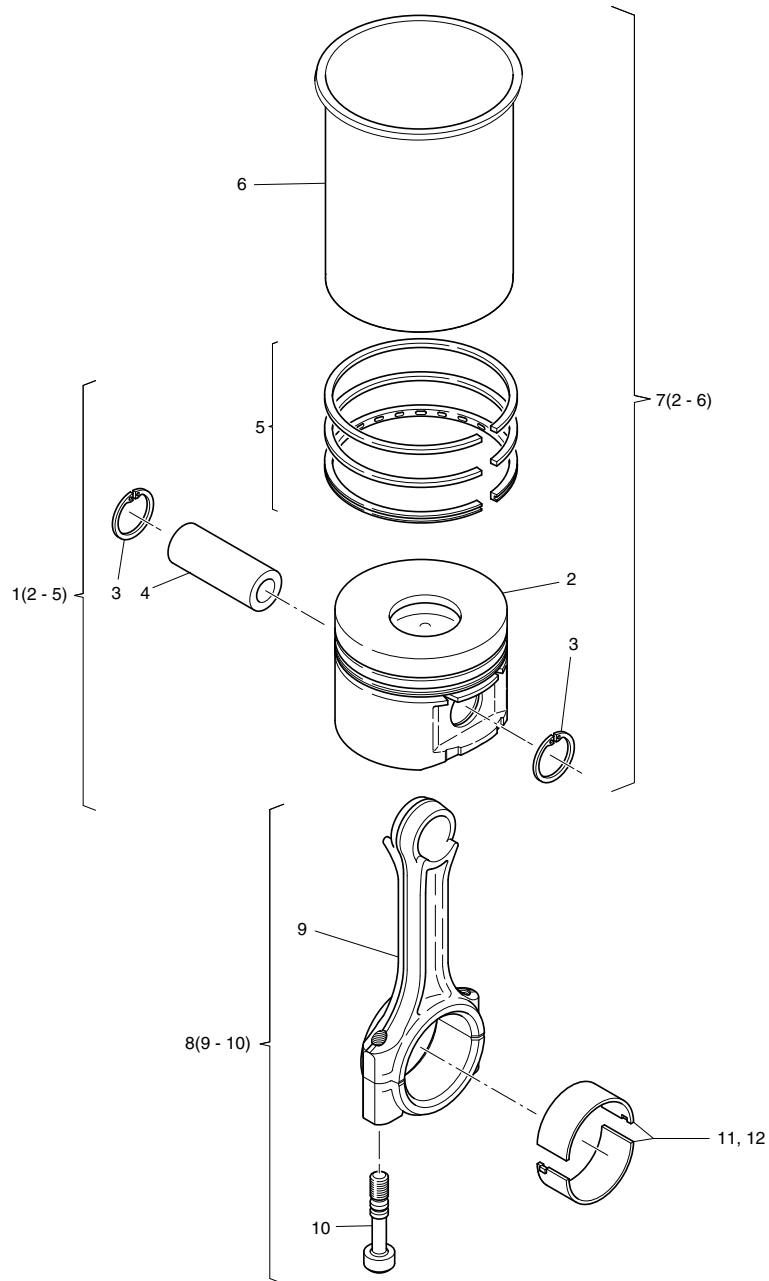

Fig.- No.	HATZ Ident-No.	Stück Qty.		W d / D	Bemerkungen Notes
		1B20V	1B30V EPA IV		
1	0000 013 481 30	1	-		69 mm Hub 65mm
1	0000 013 906 20	-	1		80 mm
2	-----	-	-		
3	0000 504 255 00	2	-		18 x 1 DIN 472
3	0000 504 640 00	-	2		
4	-----	-	-		
5	0000 013 480 00	1	-		1,5-1,5-3,0mm
5	0000 013 907 00	-	1		
6	-----	-	-		
7	0000 015 545 30	1	-		Hub 65mm
7	0000 015 826 20	-	1		
8	0000 015 001 00	1	-		
8	0000 013 292 01	-	1		
9	-----	-	-		
10	0000 050 469 00	2	-		
10	0000 041 131 00	-	2		
11	0000 015 757 00	1	-		
11	0000 015 821 00	-	1		
12	0000 015 819 00	1	-		-0,5 mm
12	0000 015 820 00	-	1		-0,5 mm

M07a

Zylinderkopf - 1B20V
 Cylinder head - 1B20V
 Culasse - 1B20V
 Culata - 1B20V
 Testa - 1B20V

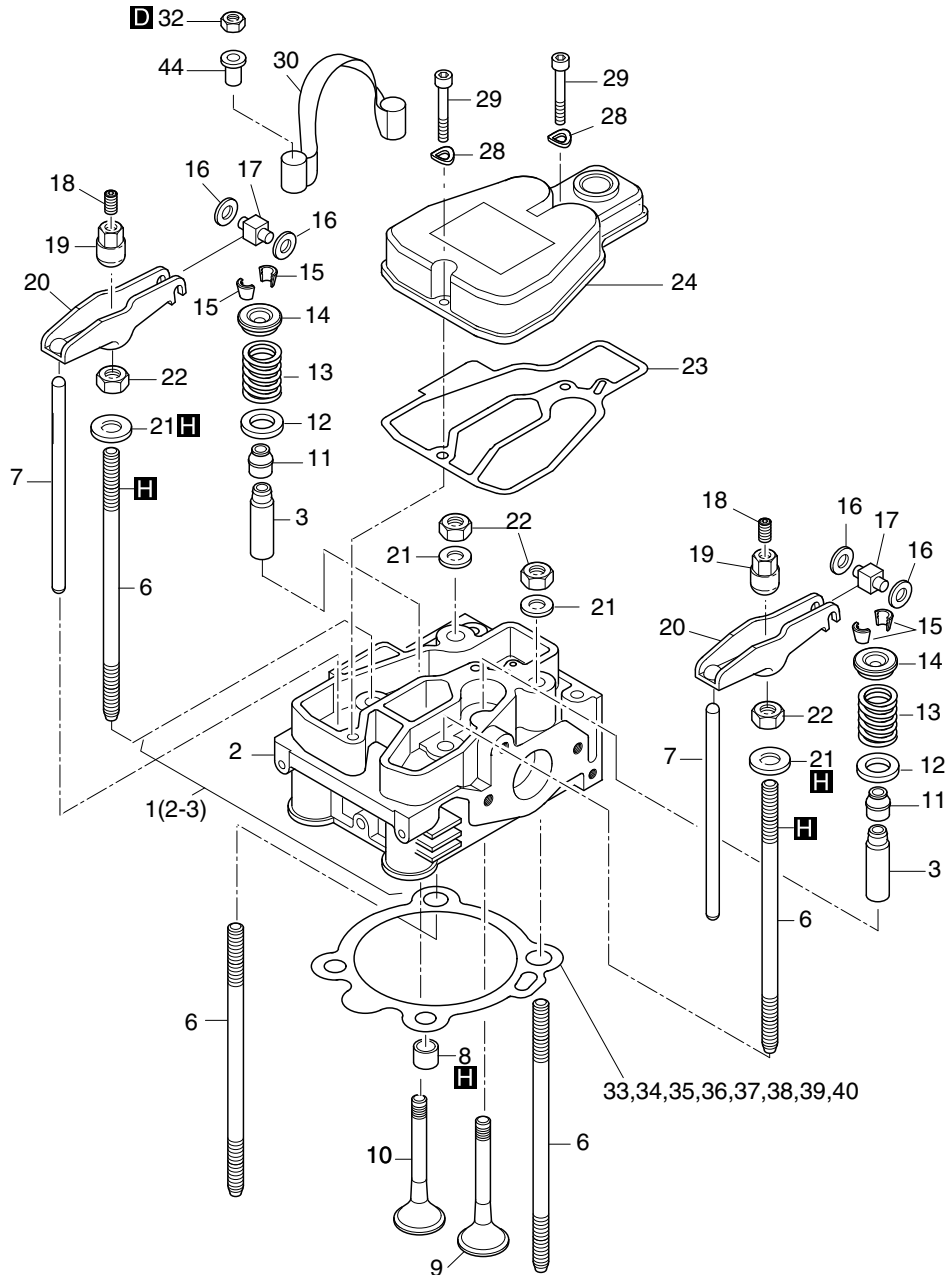

Fig.- No.	HATZ Ident-No.	Stück Qty.	W d / D	Bemerkungen Notes
		1B20V		
1	0000 013 935 00	1		
2	-----	-		
3	0000 051 194 00	2		
6	0000 050 625 00	4		128 mm
7	0000 050 540 00	2		
8	0000 041 075 00	2	d2	
9	0000 050 532 00	1		
10	0000 050 533 00	1		
11	0000 504 258 00	2	d2	
12	0000 040 937 00	2		
13	0000 040 936 00	2		
14	0000 040 938 00	2		
15	0000 022 525 00	2		
16	0000 052 407 00	0... 4		6 x 12 x 1,35
16	0000 504 451 00	0... 4		6 x 12 x 1,2 DIN 988
17	0000 050 911 01	2		
18	0000 505 131 00	2	W2	M 8 x 10 DIN 916 - 45 H
19	0000 050 547 00	2		
20	0000 050 509 02	2		
21	0000 050 612 01	4		8,1 x 20 x 3
22	0000 503 643 00	4		M 8 DIN 934 - 10.9 A3C
23	0000 050 557 00	1	d1, W4	
24	0000 050 473 21	1		
28	0000 500 812 00	2		A 6 DIN 137 - A3C
29	0000 503 749 00	2		M 6 x 35 DIN 912-8.8 A3C
30	0000 041 176 10	1		
32	0000 501 295 00	2		M 8 DIN 985-8 A3C
33	0000 050 594 00	0... 1		0,3 mm
33	0000 042 520 00	0... 1		0,35 mm
34	0000 050 595 00	0... 1		0,4 mm
34	0000 042 521 00	0... 1		0,45 mm
35	0000 050 596 00	0... 1	d1	0,5 mm
35	0000 042 522 00	0... 1		0,55 mm
36	0000 050 597 00	0... 1	d1	0,6 mm
36	0000 042 523 00	0... 1		0,65 mm
37	0000 050 598 00	0... 1	d1	0,7 mm
37	0000 042 524 00	0... 1		0,75 mm
38	0000 050 599 00	0... 1		0,8 mm
38	0000 042 525 00	0... 1		0,85 mm
39	0000 050 600 00	0... 1		0,9 mm
39	0000 042 526 00	0... 1		0,95 mm
40	0000 050 601 00	0... 1		1,0 mm
44	0000 505 259 00	2		A 10 x 0,75 x 10 DIN 7340

M07b

Zylinderkopf - 1B30V
 Cylinder head - 1B30V
 Culasse - 1B30V
 Culata - 1B30V
 Testa - 1B30V

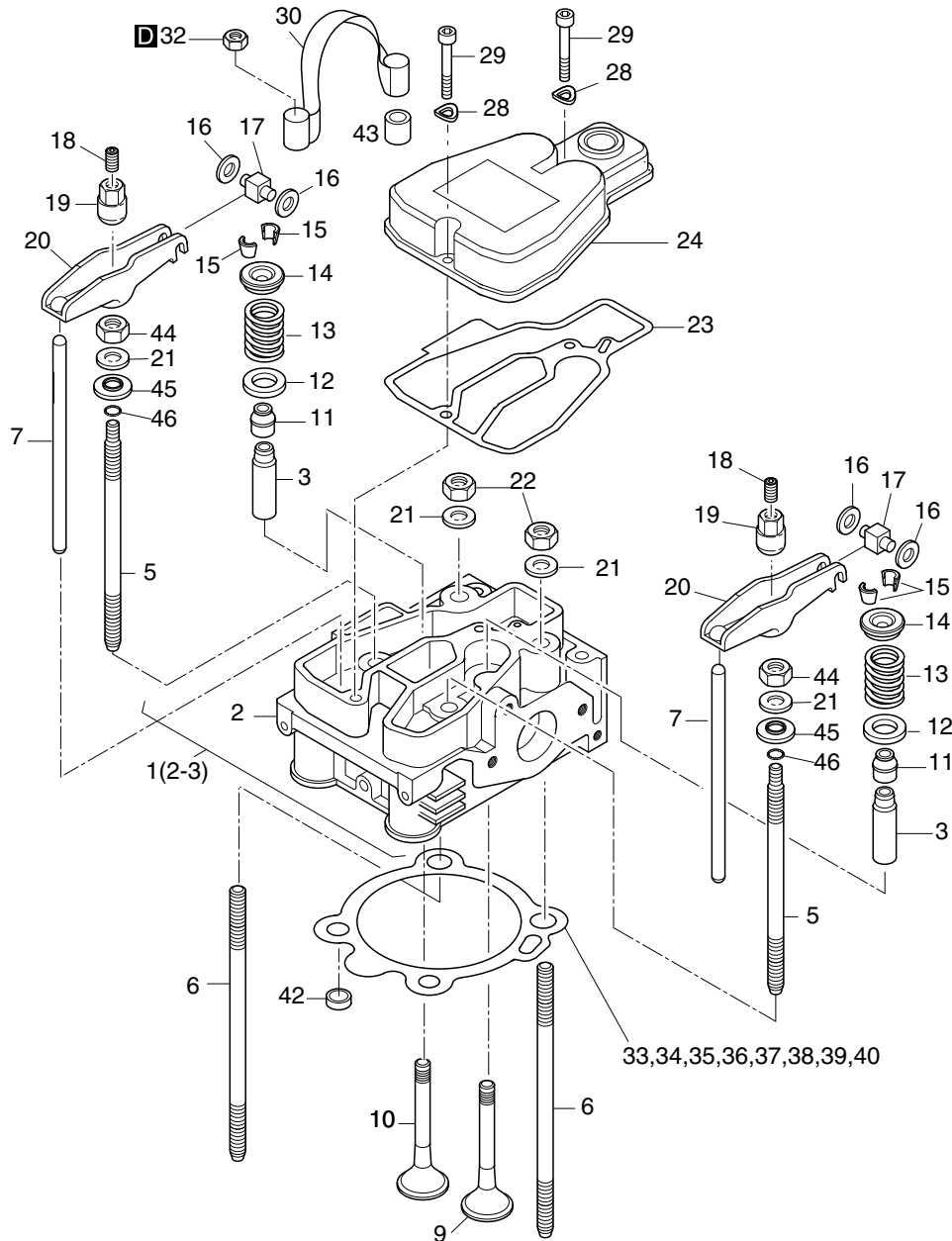

Fig.- No.	HATZ Ident-No.	Stück Qty.	W d / D	Bemerkungen Notes
		1B30V EPA IV		
1	0000 013 936 10	1		
2	-----	-		
3	0000 051 295 00	2		
5	0000 050 975 00	2		141 mm (M 10 - M 8)
6	0000 050 974 00	2		148 mm (M 10)
7	0000 050 989 00	2		174,8 mm
9	0000 050 930 00	1		
10	0000 050 931 00	1		
11	0000 504 258 00	2	d2	
12	0000 040 937 00	2		
13	0000 041 135 00	2		
14	0000 040 938 00	2		
15	0000 022 525 00	2		
16	0000 052 407 00	0... 4		6 x 12 x 1,35
16	0000 504 451 00	0... 4		6 x 12 x 1,2 DIN 988
17	0000 050 911 01	2		
18	0000 505 131 00	2		W2 M 8 x 10 DIN 916 - 45 H
19	0000 050 547 00	2		
20	0000 050 982 02	2		
21	0000 050 993 00	4		10,1 x 24 x 3
22	0000 503 966 00	2		M 10 DIN 934-10 A3C
23	0000 050 933 10	1	d1, W4	
24	0000 050 927 20	1		
28	0000 500 812 00	2		A 6 DIN 137 - A3C
29	0000 503 749 00	2		M 6 x 35 DIN 912-8.8 A3C
30	0000 041 177 01	1		
32	0000 500 238 00	2		BM 10 DIN 439 - A3C
33	0000 050 963 01	0... 1		0,3 mm
34	0000 050 964 01	0... 1		0,4 mm
35	0000 050 965 01	0... 1	d1	0,5 mm
35	0000 042 488 00	0... 1		0,55 mm
36	0000 050 966 01	0... 1	d1	0,6 mm
36	0000 042 489 00	0... 1		0,65 mm
37	0000 050 967 01	0... 1	d1	0,7 mm
37	0000 042 490 00	0... 1		0,75 mm
38	0000 050 968 01	0... 1		0,8 mm
39	0000 050 969 01	0... 1		0,9 mm
40	0000 050 970 01	0... 1		1,0 mm
42	0000 042 290 00	2		10 x 11,5 x 4,5
43	0000 041 261 00	2		(10 x 12 x 9)
44	0000 503 966 00	2		M 10 DIN 934-10 A3C
45	0000 042 437 00	2		
46	0000 505 639 00	2	d2	10x 2,5

M10, M32

Ölpumpe, Regler, Drehzahlverstellung
 Oil pump, governor, speed control
 Pompe à huile, regulateur regime, réglage régime
 Bomba de aceite, regulador, ajuste de revoluciones
 Pompa olio, regolatore di giri, Comando acceleratore

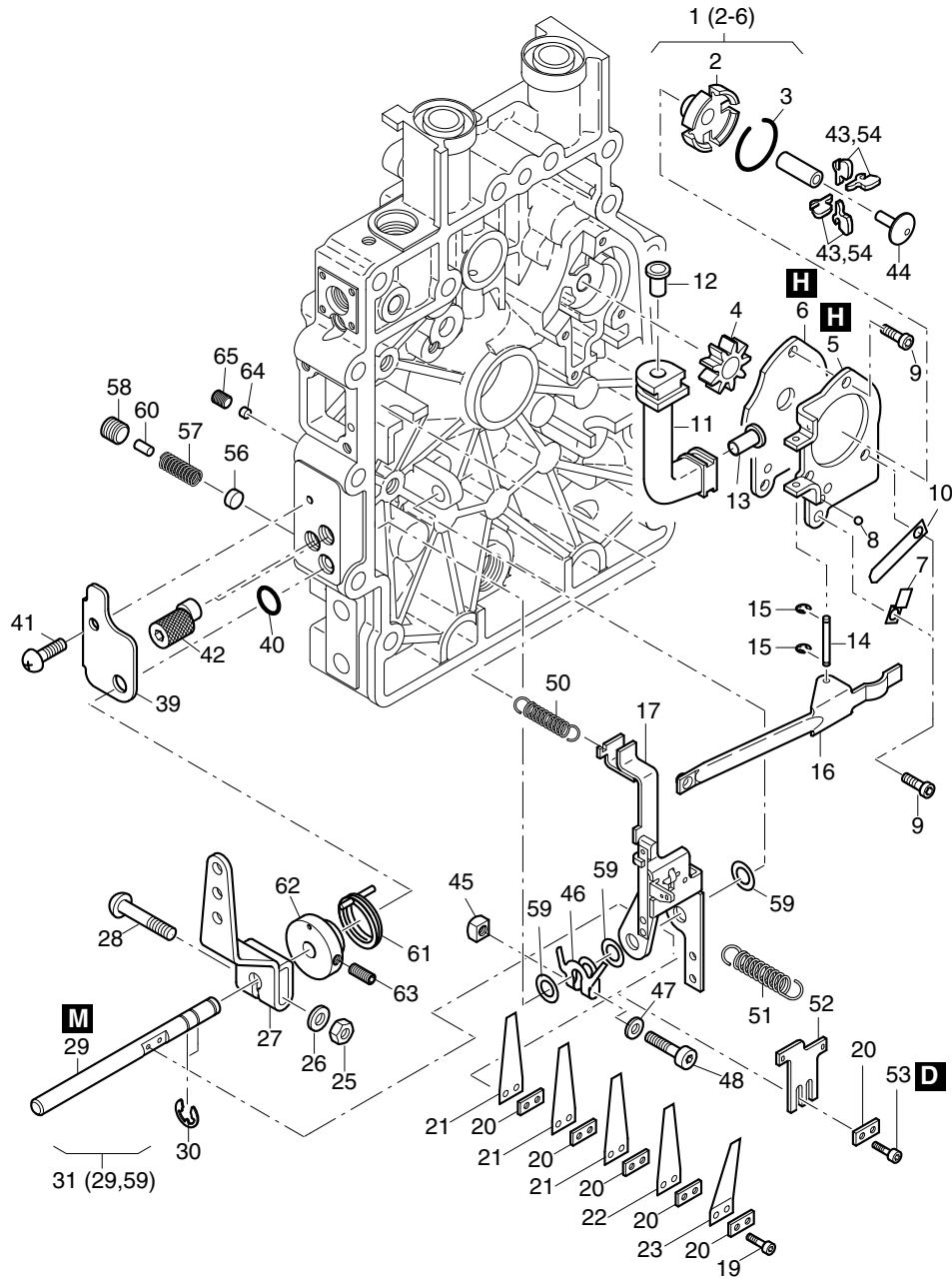

Fig.- No.	HATZ Ident-No.	Stück Qty.		W d / D	Bemerkungen Notes
		1B20V	1B30V EPA IV		
1	0000 015 302 20	1	1		
2	-----	-	-		
3	0000 042 109 10	1	1		
4	-----	-	-		
5	-----	-	-		
6	-----	-	-		
7	0000 050 971 00	1	1		
8	0000 504 479 00	1	1		3,5mm KL. III
9	0000 504 294 00	4	4		M5 x 12 DIN 6912 - 8.8
10	0000 050 973 00	1	1		0,4 mm
11	0000 041 029 00	1	1		
12	0000 504 474 00	1	1		A8 x 0,5 x 12 DIN 7340 - St
13	0000 504 475 00	1	1		A10 x 0,75 x 12 DIN 7340 - St
14	0000 050 786 00	1	1		
15	0000 504 348 00	2	2		1,9 DIN 6799
16	0000 050 794 01	1	1		
17	0000 015 304 04	1	1		
19	0000 504 350 00	2	2		M 3 x 12 DIN 912-8.8
20	0000 050 798 00	1...5	1...5		
21	0000 051 316 00	1...2	1...3		0,2 mm Gen-PV 78
22	0000 050 789 00	1...2	1		0,3 mm Gen-PV 78
23	0000 051 486 00	1	1		0,4 mm 19°Gen-PV 78
25	0000 503 465 00	1	1		M 6 DIN 934 - 10 A2F
26	0000 501 445 00	1	1		6,4 DIN 125-St A3C
27	0000 040 956 00	1	1		
28	0000 039 273 01	1	1		M 6 x 32
29	-----	-	-		
30	0000 500 927 00	2	2		7 DIN 6799 A3C
31	0000 019 810 00	1	1		
39	0000 051 784 00	1	1		
40	0000 400 224 01	1	1		D1 8 x 2 FPM 75 MOLYKOT.
41	0000 504 923 00	1	1		M 5 x 12 ISO 7380-10.9 Zn
42	0000 051 788 10	2	2		
43	0000 050 796 11	0... 4	0... 4		Gen PV 78 (0)
44	0000 050 785 02	1	1		
45	0000 504 227 00	1	1		M 5 DIN 557-5 A3C
46	0000 051 785 00	1	1		
47	0000 502 163 00	1	1		5,3 DIN 125-St A3C
48	0000 504 922 00	1	1		M 5 x 25 DIN 6912-8.8
50	0000 505 634 00	1	1		
51	0000 051 309 10	0... 1	0... 1		
52	0000 051 308 00	1	1		
53	0000 504 653 00	2	2		M 3 x 8 DIN 912-8.8
54	0000 051 602 11	0... 4	0... 4		Gen PV 78 (4)
56	0000 051 517 00	0... 1	0... 1		

M10, M32

Ölpumpe, Regler, Drehzahlverstellung
 Oil pump, governor, speed control
 Pompe à huile, régulateur regime, réglage régime
 Bomba de aceite, regulador, ajuste de revoluciones
 Pompa olio, regolatore di giri, Comando acceleratore

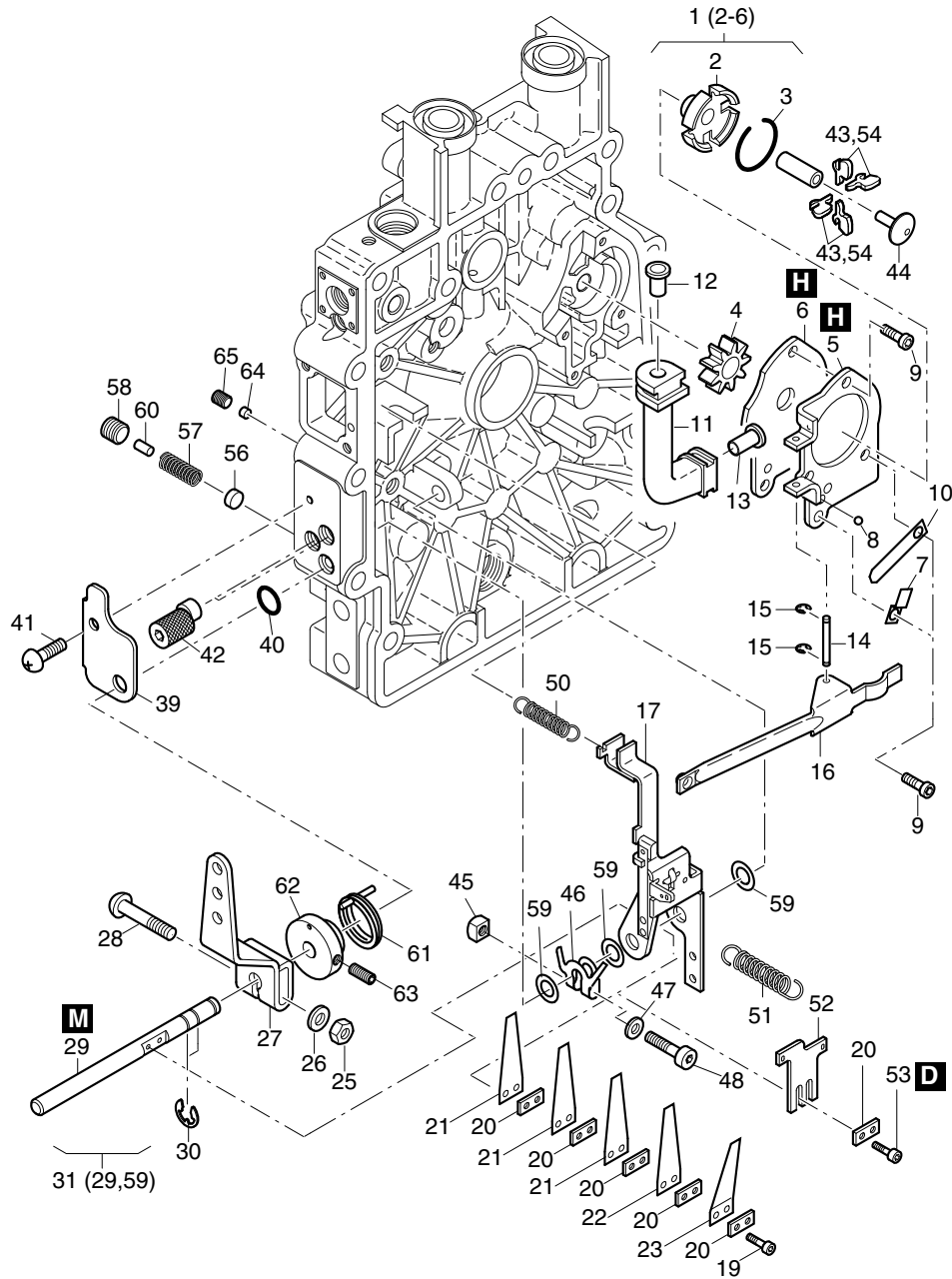

Fig.- No.	HATZ Ident-No.	Stück Qty.		W d / D	Bemerkungen Notes
		1B20V	1B30V EPA IV		
57	0000 504 887 00	0... 1	0... 1		
58	0000 504 757 00	1	1		M 10 x 10 DIN 913-A3C Tuf.
59	0000 504 224 00	3	3		8 x 14 x 1,0 DIN 988
60	0000 505 996 00	0... 1	0... 1		4 x 10 ISO 8734-A-ST
61	0000 051 791 00	0... 1	0... 1		
62	0000 051 790 00	0... 1	0... 1		
63	0000 504 006 00	0... 1	0... 1		M 5 x 10 DIN 916-45H A3C
64	0000 053 073 00	1	1		4,5 x 3
65	0000 505 746 00	1	1		M 6 x 10 DIN 913-45H-A3C

M11

Steuerdeckel
Timing cover
Couvercle distribution
Tapa de mando
Coperchio distribuzione

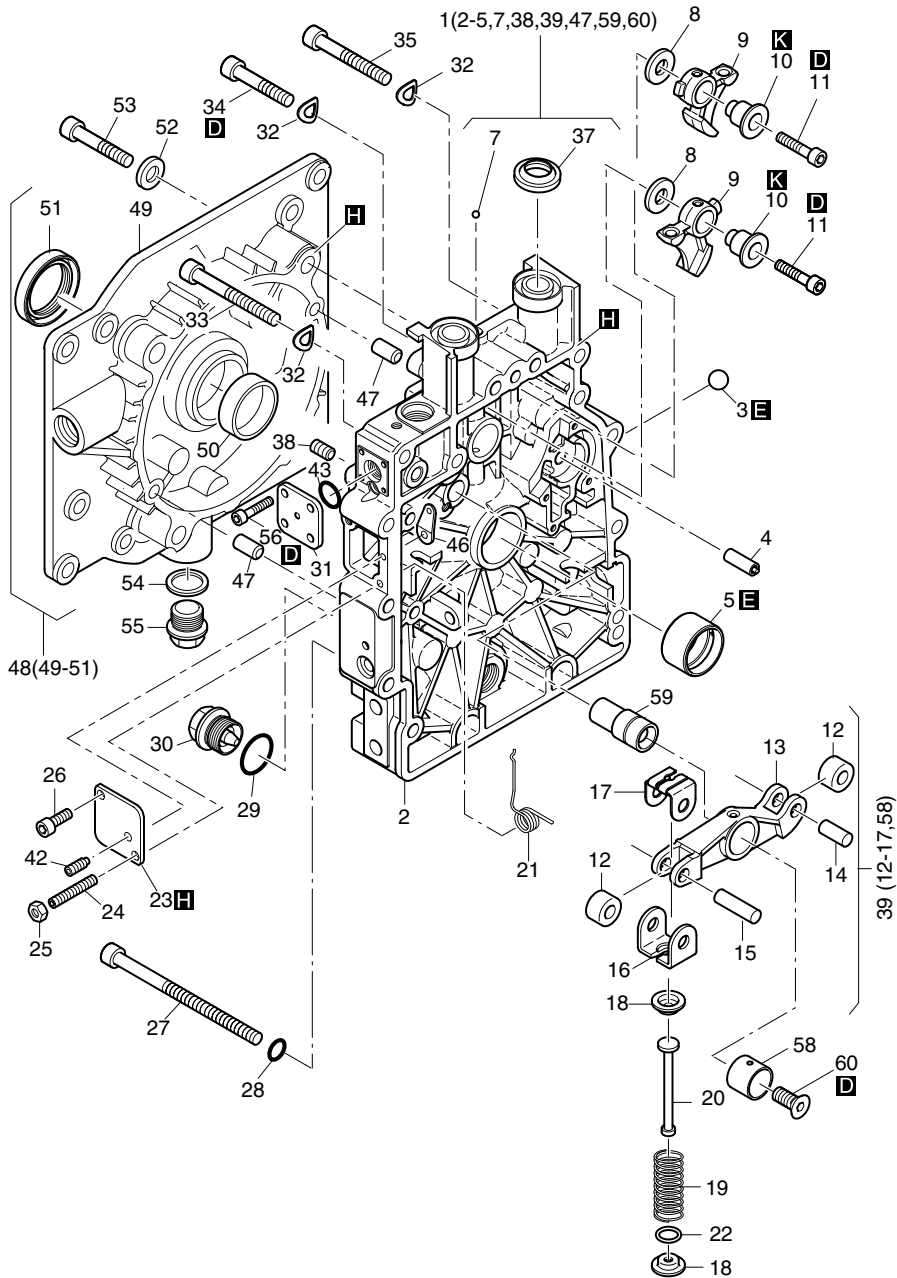

Fig.- No.	HATZ Ident-No.	Stück Qty.		W d / D	Bemerkungen Notes
		1B20V	1B30V EPA IV		
1	0000 013 401 20	1	1		
2	-----	-	-		
3	-----	-	-		
4	0000 015 339 00	1	1		
5	0000 050 531 00	1	1		
5	0000 041 248 00	1	1		-0,5 mm
7	-----	-	-		
8	0000 037 941 00	2	2		10,1 x 22 x 3
9	0000 050 534 00	2	2		
10	0000 037 942 01	2	2		
11	0000 504 579 00	2	2		M 6 x 25 DIN 912 - 10.9
12	-----	-	-		
13	-----	-	-		
14	-----	-	-		
15	-----	-	-		
16	-----	-	-		
17	-----	-	-		
18	0000 040 948 02	2	2		
19	0000 040 957 00	1	1		
20	0000 040 947 00	1	1		
21	0000 050 952 10	1	1		
22	0000 041 339 00	1	1		10,7 x 16 x 0,5
23	0000 040 952 10	1	1		
24	0000 504 489 01	1	1		M 6 x 30 DIN 913 22 H A3C Tuf.
25	0000 501 444 00	1	1		M 6 DIN 934 - 8 A3C
26	0000 503 842 00	1	1		M 6x12 DIN 912-8.8 A3C Tuf.
27	0000 504 261 00	2	-		M 8 x 120 DIN 912 - 8.8 A3C
27	0000 504 630 00	-	2		M 8 x 130 DIN 912 - 8.8 A3C
28	0000 501 629 00	2	2		D2 A 8 x 14 DIN 7603 - Cu
29	0000 504 698 00	1	1		W4, D1 A 22 x 27 DIN 7603 - Vf
30	0000 503 731 00	1	1		W1 AM22x1,5DIN7604A3C MAGN.
31	0000 013 517 00	1	1		
32	0000 500 951 00	13	13		A 8 DIN 137 A3C
33	0000 502 488 00	1	1		M 8 x 60 DIN 912 - 8.8 A3C
34	0000 504 534 01	2	2		M 8 x 45 DIN 912 - 8.8 A3C Tuf.
35	0000 503 929 00	10	10		M 8 x 50 DIN 912 - 8.8 A3C
37	0000 041 065 01	2	2		d2
38	0000 505 306 00	5	5		M 8 x 10 DIN 913 - 45H-A3C-KL
39	0000 013 196 20	1	1		
42	0000 502 749 01	1	1		M 4 x 20 DIN 915-Tuf. 360 G
43	0000 503 290 00	1	1		D1 9,5 x 2,5
46	0000 051 271 00	1	1		
47	0000 502 491 02	2	2		8 M 6 x 20 2-Fasen
48	0000 016 267 01	1	1		
49	-----	-	-		

M11

Steuerdeckel
Timing cover
Couvercle distribution
Tapa de mando
Coperchio distribuzione

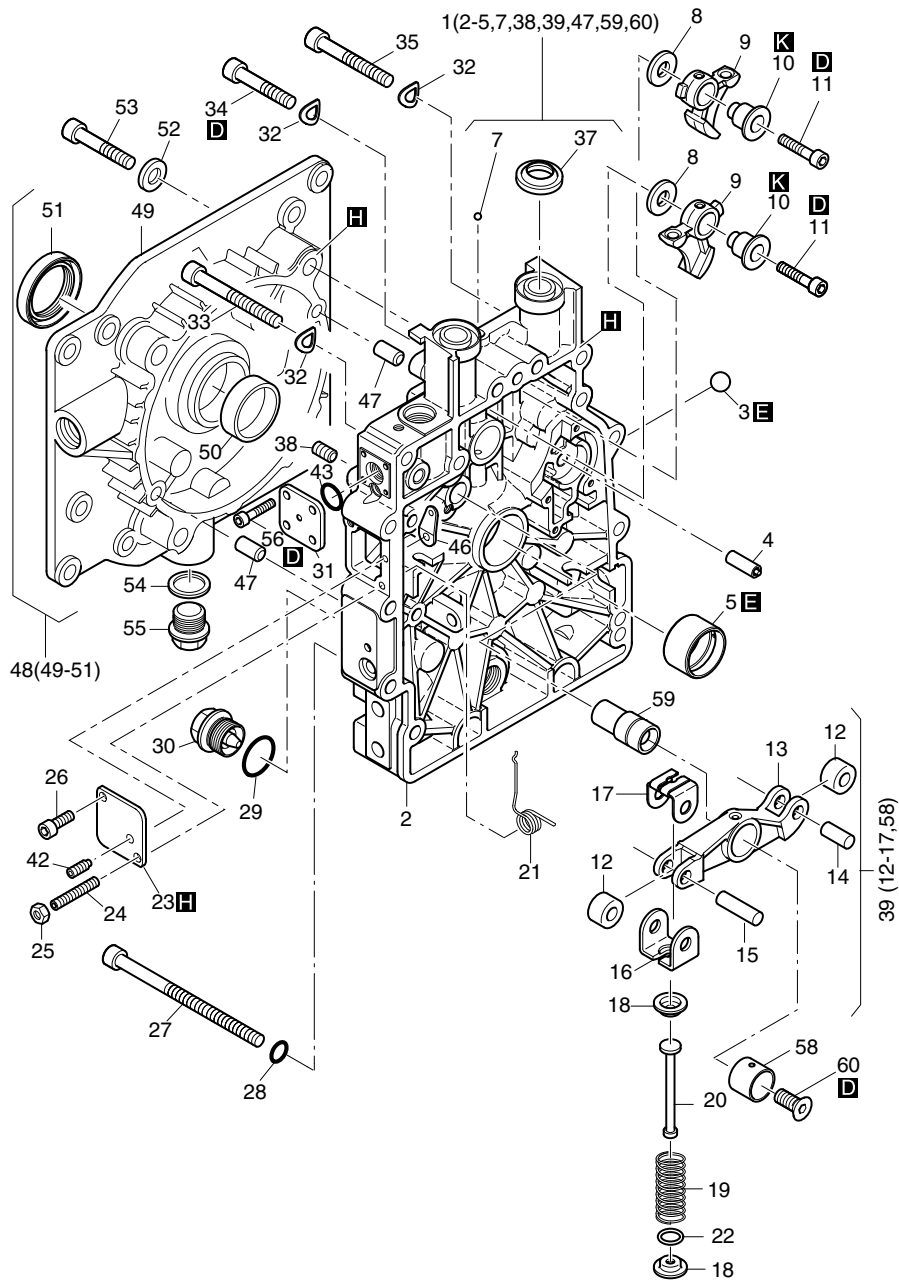

Fig.- No.	HATZ Ident-No.	Stück Qty.		W d / D	Bemerkungen Notes
		1B20V	1B30V EPA IV		
50	0000 501 934 00	1	1		
51	0000 400 337 01	1	1		
52	0000 500 170 00	4	4		D1 30 x 47 x 7
53	0000 504 755 00	4	4		10,5 DIN 433 - St A3C
54	0000 500 014 00	2	2		M 10 x 45 DIN 6912 - 8.8 A3C
55	0000 500 442 00	2	2		D2, W4 A 18 x 22 DIN 7603 - Cu
56	0000 503 971 00	4	4		W1 M 18 x 1,5 DIN 910
58	-----	-	-		M 4 x 10 DIN 912-8.8 A3C Tuf.
59	0000 040 968 30	1	1		
60	0000 504 450 00	1	1		M 6 x 35 DIN 7991 - 8.8 A3C

M13, M17

Gebälse, Schwungrad
 Blower, flywheel
 Soufflerie, volant
 Ventilador, volante
 Ventilatore, volano

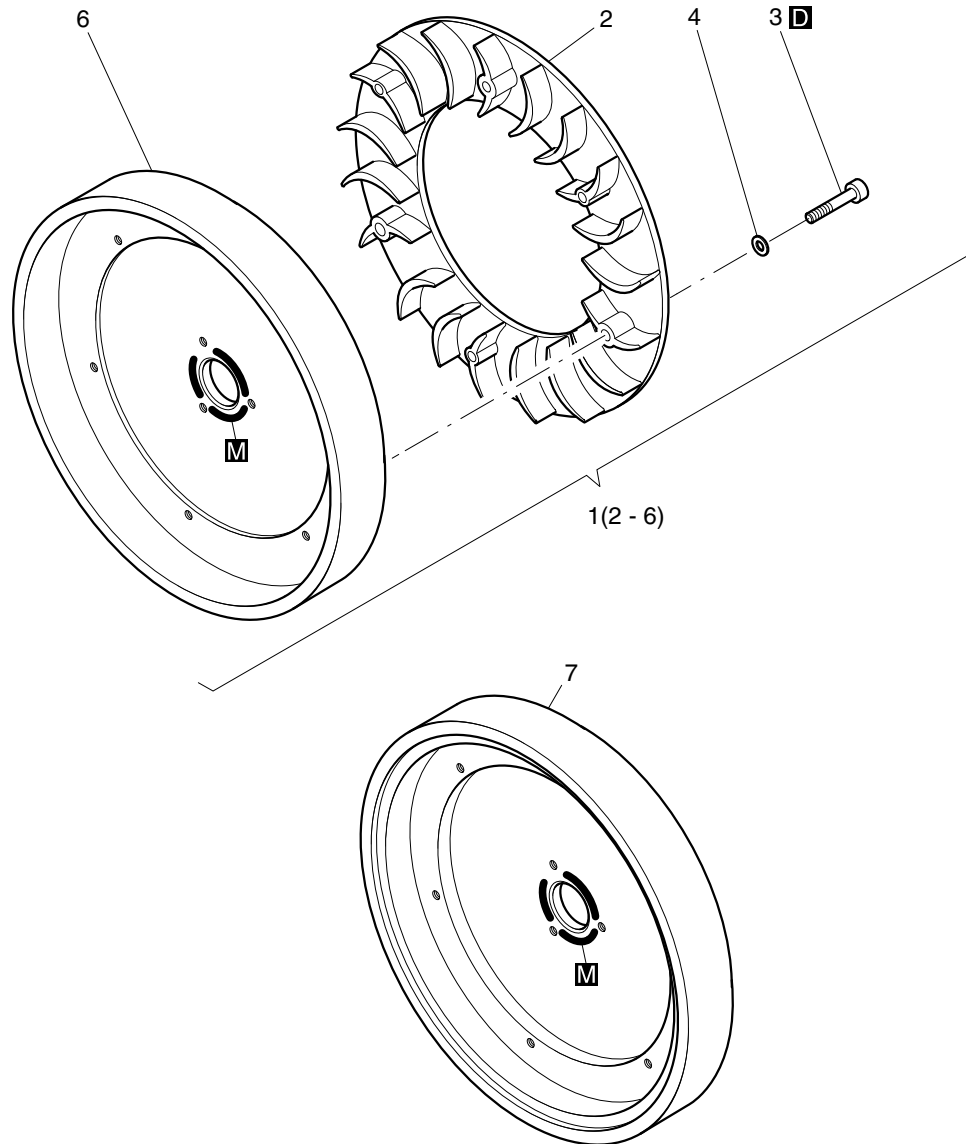

Fig.- No.	HATZ Ident-No.	Stück Qty.		W d / D	Bemerkungen Notes
		1B20V	1B30V EPA IV		
1	0000 015 797 10	1	-		
2	0000 041 937 00	1	-		
2	0000 041 936 00	-	1		
3	0000 503 273 00	6	6		M 4 x 20 DIN 912 - 8.8 A3C
4	0000 500 034 00	6	6		A 4 DIN 137 - ST
6	0000 050 522 20	1	-		
6	0000 041 103 02	-	0... 1		leicht, light, léger
7	0000 013 977 00	-	0... 1		schwer, heavy, lourde

M14a

Einspritzausrstung - 1B20V
 Injection equipment - 1B20V
 Equipment d'injection - 1B20V
 Equipo de inyeccin - 1B20V
 Equipaggiamento di iniezione - 1B20V

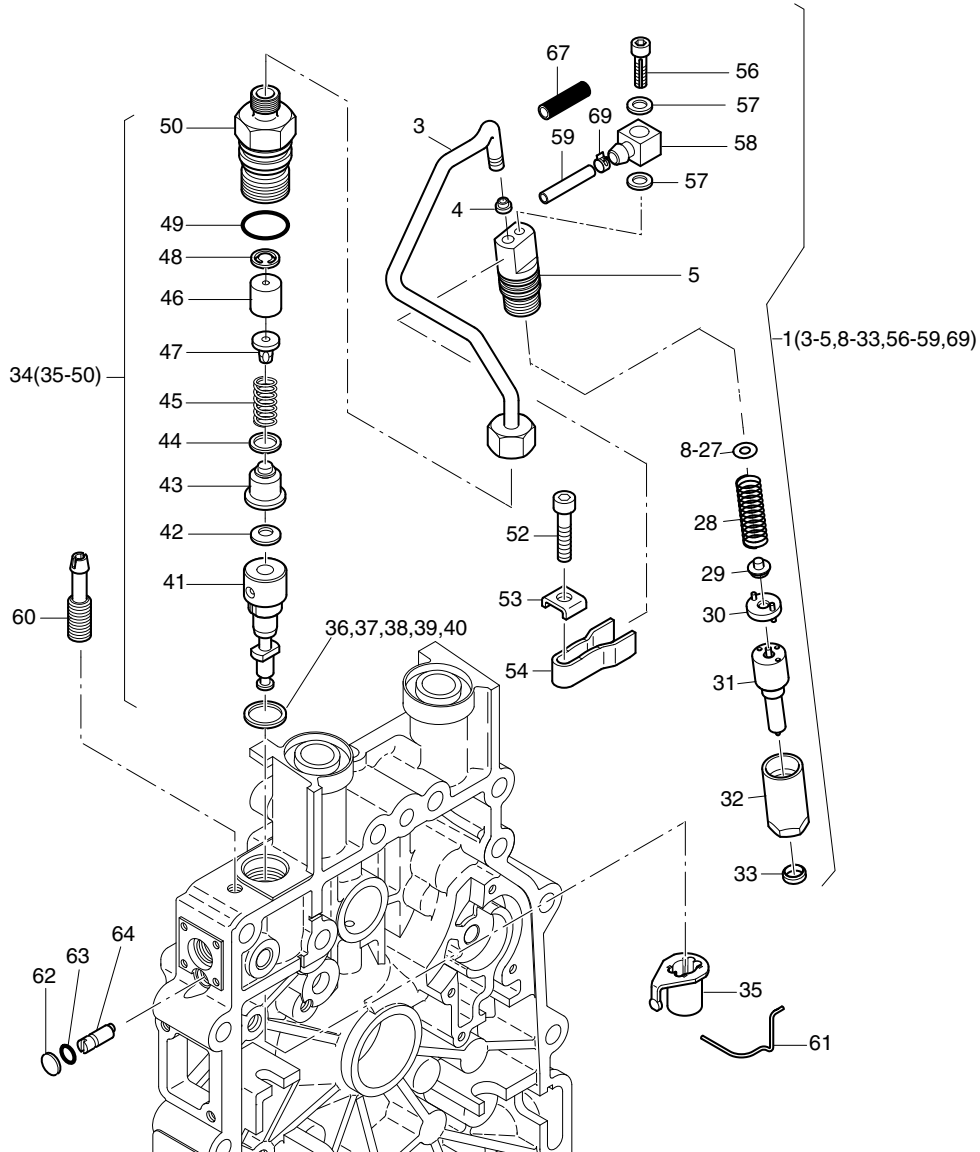

Fig.- No.	HATZ Ident-No.	Stck Qty.	W d / D	Bemerkungen Notes
		1B20V		
1	0000 013 940 10	1		
3	-----	-		
4	0000 050 706 01	1		5,3 mm s. 95125802
5	-----	-		
8	0000 504 364 00	0... 1		1,00 mm
9	0000 504 365 00	0... 1		1,04 mm
10	0000 504 366 00	0... 1		1,10 mm
11	0000 504 367 00	0... 1		1,14 mm
12	0000 504 368 00	0... 1		1,20 mm
13	0000 504 369 00	0... 1		1,24 mm
14	0000 504 370 00	0... 1		1,30 mm
15	0000 504 371 00	0... 1		1,34 mm
16	0000 504 372 00	0... 1		1,40 mm
17	0000 504 373 00	0... 1		1,44 mm
18	0000 504 374 00	0... 1		1,50 mm
19	0000 504 375 00	0... 1		1,54 mm
20	0000 504 376 00	0... 1		1,60 mm
21	0000 504 377 00	0... 1		1,64 mm
22	0000 504 378 00	0... 1		1,70 mm
23	0000 504 379 00	0... 1		1,74 mm
24	0000 504 380 00	0... 1		1,80 mm
25	0000 504 381 00	0... 1		1,84 mm
26	0000 504 382 00	0... 1		1,90 mm
27	0000 504 383 00	0... 1		1,94 mm
28	-----	-		
29	-----	-		
30	-----	-		
31	0000 505 765 10	1		
32	-----	-		
33	0000 050 705 00	1		
34	0000 013 222 40	1		
35	0000 013 308 01	1		
36	0000 040 963 00	0... 1		0,2 mm
37	0000 040 964 00	0... 1		0,3 mm
38	0000 040 965 00	0... 1		0,4 mm
39	0000 040 966 00	0... 1		0,5 mm
40	0000 040 967 00	0... 1		0,6 mm
41	-----	-		
42	0000 041 652 00	1		8
43	-----	-		
44	0000 504 769 00	1		9,5 x 13 x 0,5
45	-----	-		
46	-----	-		
47	-----	-		
48	0000 051 808 00	1		

M14a

Einspritzausrstung - 1B20V
 Injection equipment - 1B20V
 Equipment d'injection - 1B20V
 Equipo de inyeccin - 1B20V
 Equipaggiamento di iniezione - 1B20V

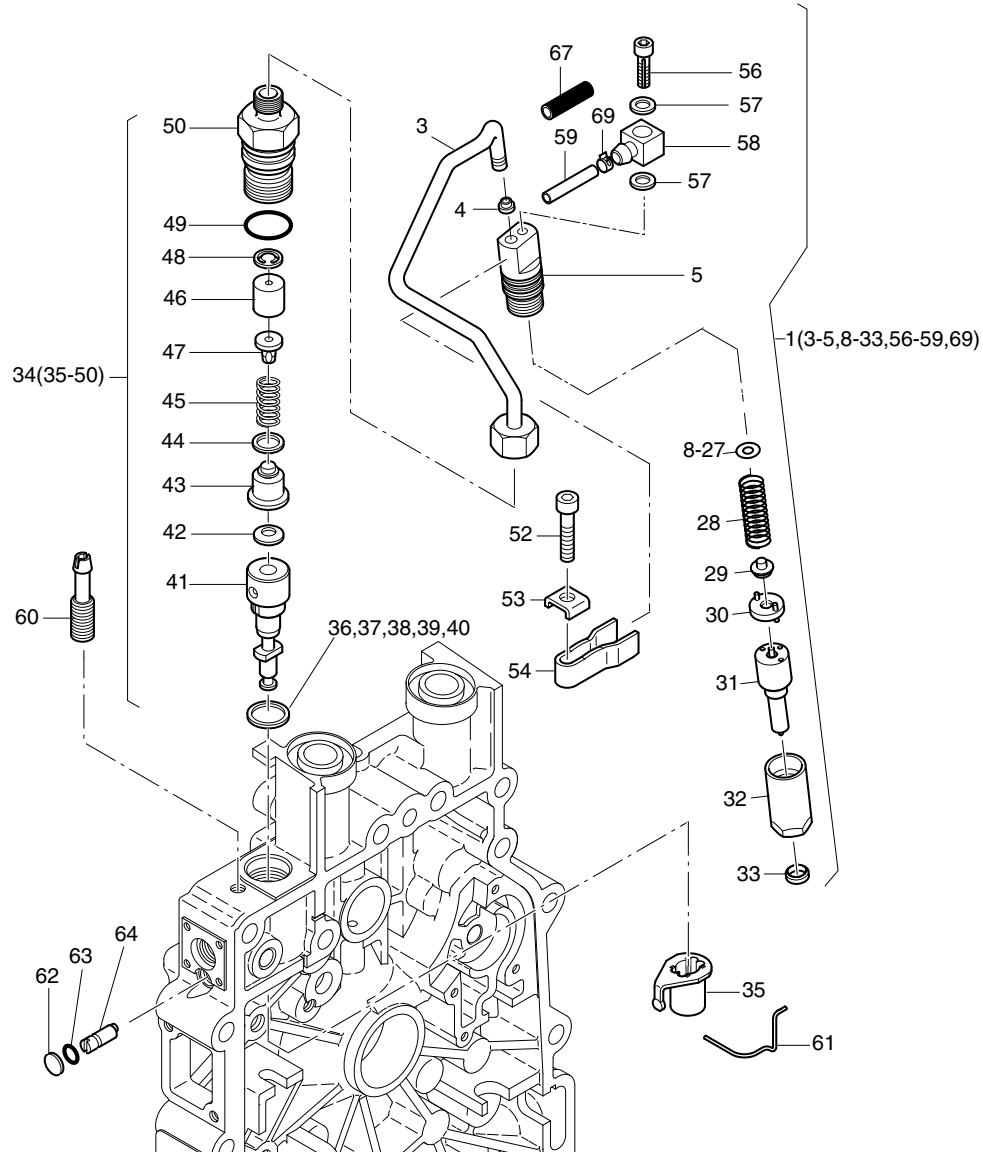

Fig.- No.	HATZ Ident-No.	Stck Qty.	W d / D	Bemerkungen Notes
		1B20V		
49	0000 504 892 00	1	D1 17 x 2	
50	0000 051 811 00	1		
52	0000 503 239 00	1		M 6 x 30 DIN 912-8.8 A3C
53	0000 050 893 00	1		6,4
54	0000 050 567 00	1		
56	0000 052 990 01	1		M 4 x 16
57	0000 501 108 00	2		A4 x 8 DIN 7603-Cu
58	0000 051 290 00	1		
59	0000 051 334 00	1		
60	0000 050 842 01	1		
61	0000 041 618 00	1		
62	0000 504 760 00	1		8 DIN 470 Al
63	0000 503 301 00	1		4 x 1,2
64	0000 040 977 10	1		
67	0000 052 522 00	1		245mm \varnothing 7 mm
69	0000 505 779 00	1		6

M14b

Einspritzausrstung - 1B30V
 Injection equipment - 1B30V
 Equipment d'injection - 1B30V
 Equipo de inyeccin - 1B30V
 Equipaggiamento di iniezione - 1B30V

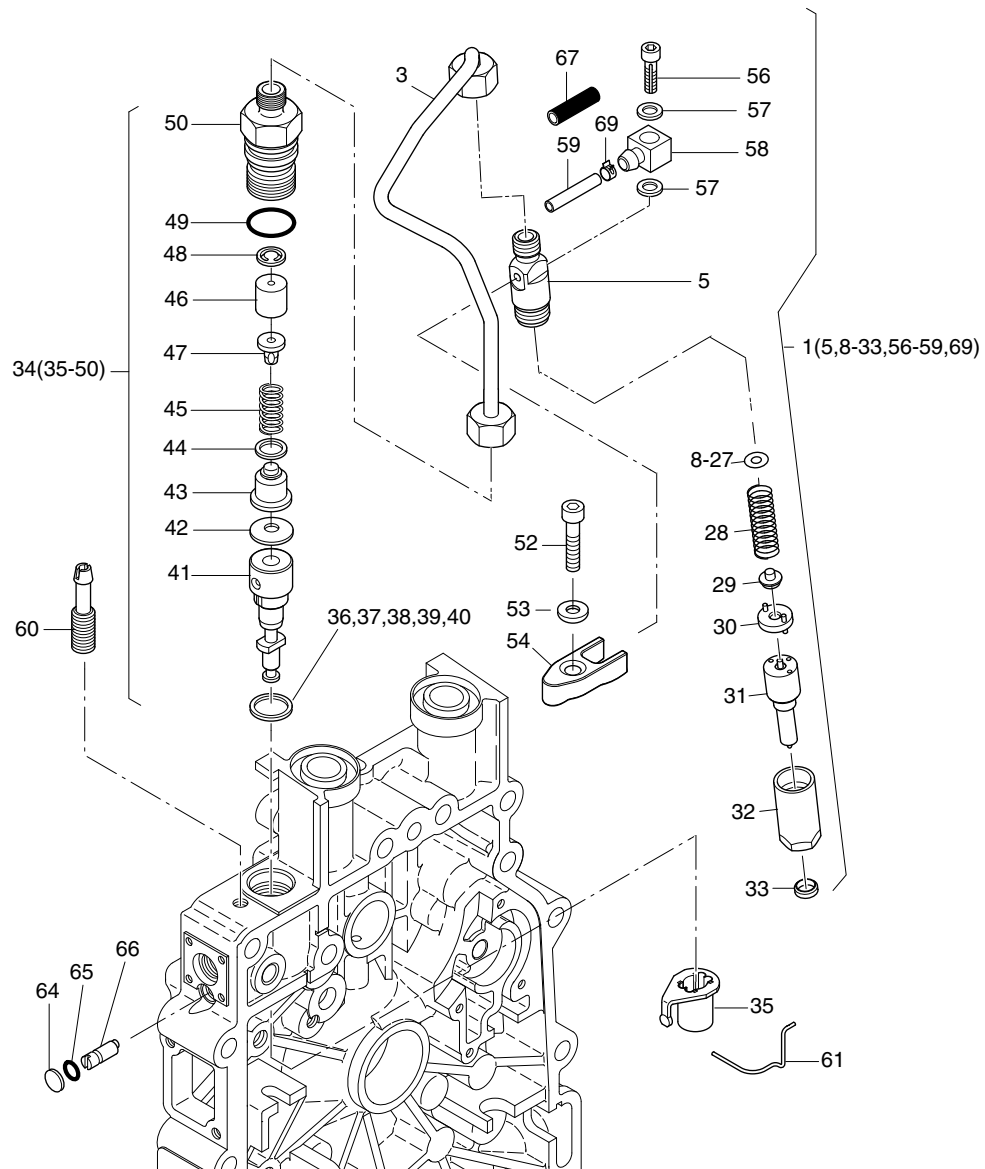

Fig.- No.	HATZ Ident-No.	Stck Qty.	W d / D	Bemerkungen Notes
		1B30V EPA IV		
1	0000 018 568 10	1		
3	0000 020 244 00	1		
5	-----	-		
8	0000 504 364 00	0 ...1		1,00 mm
9	0000 504 365 00	0 ...1		1,04 mm
10	0000 504 366 00	0 ...1		1,10 mm
11	0000 504 367 00	0 ...1		1,14 mm
12	0000 504 368 00	0 ...1		1,20 mm
13	0000 504 369 00	0 ...1		1,24 mm
14	0000 504 370 00	0 ...1		1,30 mm
15	0000 504 371 00	0 ...1		1,34 mm
16	0000 504 372 00	0 ...1		1,40 mm
17	0000 504 373 00	0 ...1		1,44 mm
18	0000 504 374 00	0 ...1		1,50 mm
19	0000 504 375 00	0 ...1		1,54 mm
20	0000 504 376 00	0 ...1		1,60 mm
21	0000 504 377 00	0 ...1		1,64 mm
22	0000 504 378 00	0 ...1		1,70 mm
23	0000 504 379 00	0 ...1		1,74 mm
24	0000 504 380 00	0 ...1		1,80 mm
25	0000 504 381 00	0 ...1		1,84 mm
26	0000 504 382 00	0 ...1		1,90 mm
27	0000 504 383 00	0 ...1		1,94 mm
28	-----	-		
29	-----	-		
30	-----	-		
31	0000 505 667 10	1		P1
32	-----	-		
33	0000 050 705 00	1		d1
34	0000 015 829 20	1		
35	0000 013 308 01	1		
36	0000 040 963 00	0 ...1		0,2 mm
37	0000 040 964 00	0 ...1		0,3 mm
38	0000 040 965 00	0 ...1		0,4 mm
39	0000 040 966 00	0 ...1		0,5 mm
40	0000 040 967 00	0 ...1		0,6 mm
41	-----	-		
42	0000 041 652 00	1		8
43	-----	-		
44	0000 504 769 00	1		9,5 x 13 x 0,5
45	-----	-		
46	-----	-		
47	-----	-		
48	0000 051 808 00	1		
49	0000 504 892 00	1		D1 17 x 2

M14b

Einspritzausrstung - 1B30V
 Injection equipment - 1B30V
 Equipment d'injection - 1B30V
 Equipo de inyeccin - 1B30V
 Equipaggiamento di iniezione - 1B30V

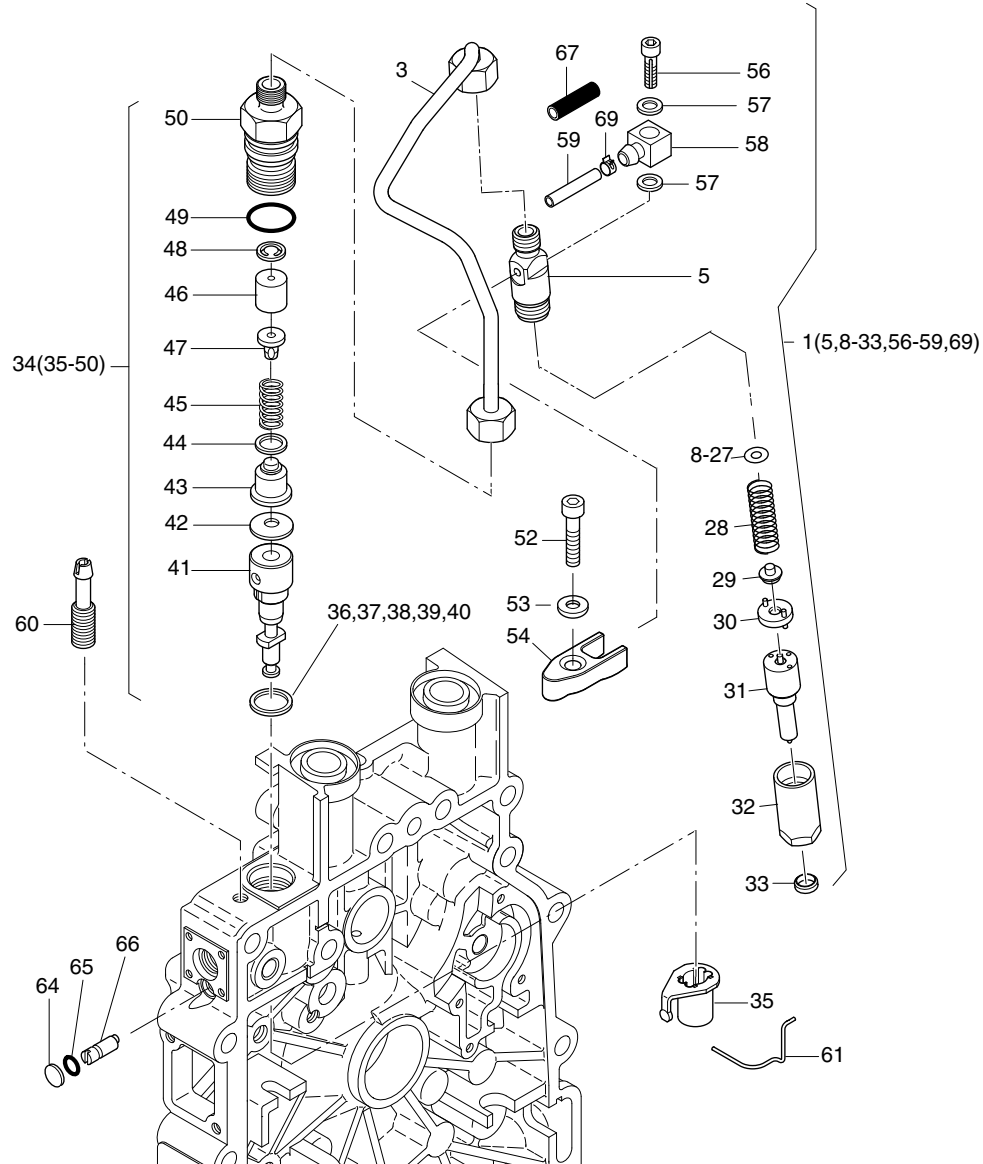

Fig.- No.	HATZ Ident-No.	Stck Qty.	W d / D	Bemerkungen Notes
		1B30V EPA IV		
50	0000 051 811 00	1		
52	0000 503 239 00	1		M 6 x 30 DIN 912-8.8 A3C
53	0000 505 965 00	1		6,4
54	0000 042 818 01	1		
56	0000 042 819 00	1		M 4 x 14
57	0000 501 108 00	2		A4 x 8 DIN 7603-Cu
58	0000 051 290 00	1		
59	0000 052 202 01	1		2,5 x 330
60	0000 050 842 01	1		
61	0000 041 618 00	1		
64	0000 504 760 00	1		8 DIN 470 Al
65	0000 503 301 00	1		4 x 1,2
66	0000 040 977 10	1		
67	0000 052 522 00	1		245mm \varnothing 7 mm
69	0000 505 779 00	1		6

M15

Reversierstarter
 Recoil starter
 Demarreur reversible
 Arrancador reversible
 Avviamento a strappo

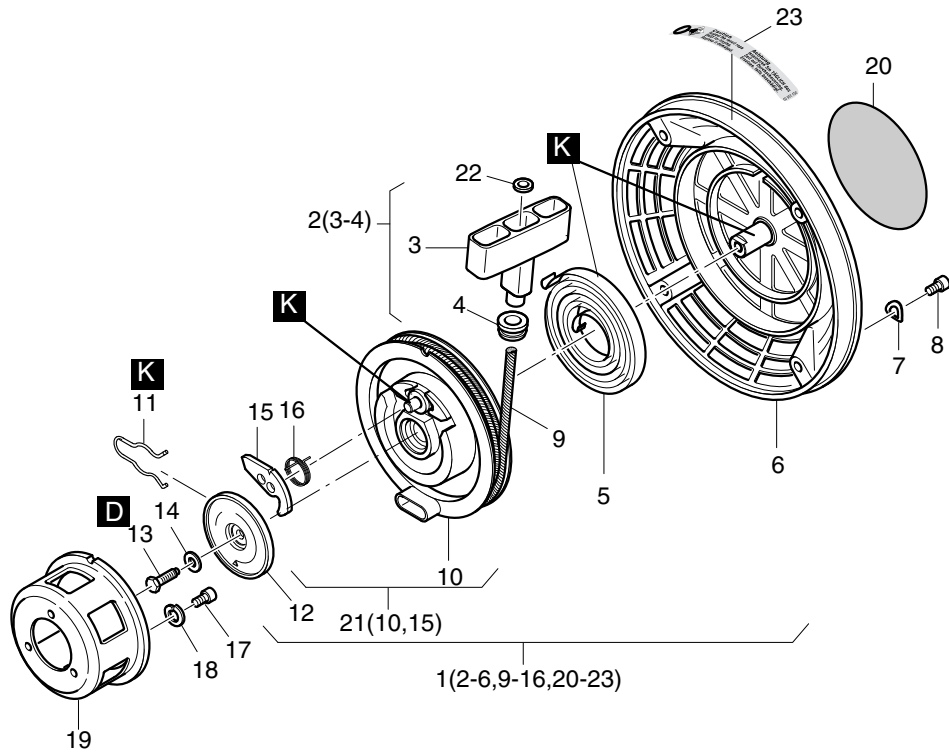

Fig.- No.	HATZ Ident-No.	Stück Qty.		W d / D	Bemerkungen Notes
		1B20V	1B30V EPA IV		
1	0000 018 652 00	1	1		
2	0000 014 978 00	1	1		
3	-----	-	-		
4	0000 036 652 00	1	1		
5	0000 050 452 02	1	1		
6	0000 015 693 00	1	1		
7	0000 500 812 00	4	4		A 6 DIN 137 - A3C
8	0000 500 627 00	4	4		M 6 x 10 DIN 912 - 8.8 A3C
9	0000 019 290 00	1	1		2040 mm
10	-----	-	-		
11	0000 050 449 01	1	1		
12	0000 050 450 01	1	1		
13	0000 501 463 00	1	1		M 6 x 18 DIN 933-8.8 A3C
14	0000 503 907 01	1	1		6 DIN 6796 - 6 - FST ZN
15	0000 050 448 00	1	1		
16	0000 050 613 00	1	1		
17	0000 500 627 00	3	3		M 6 x 10 DIN 912 - 8.8 A3C
18	0000 501 709 00	3	3		6 DIN 128 - A3C
19	0000 041 550 00	1	1		
20	0000 051 091 03	1	1		
21	0000 015 488 00	1	1		
22	0000 505 146 00	1	1		5,3 DIN 9021 PA 6.6
23	0000 053 338 00	1	1		

M26a

Luftführung - 1B20V
 Air ducting - 1B20V
 Carter ventilation - 1B20V
 Conducción de aire - 1B20V
 Carter ventilatore - 1B20V

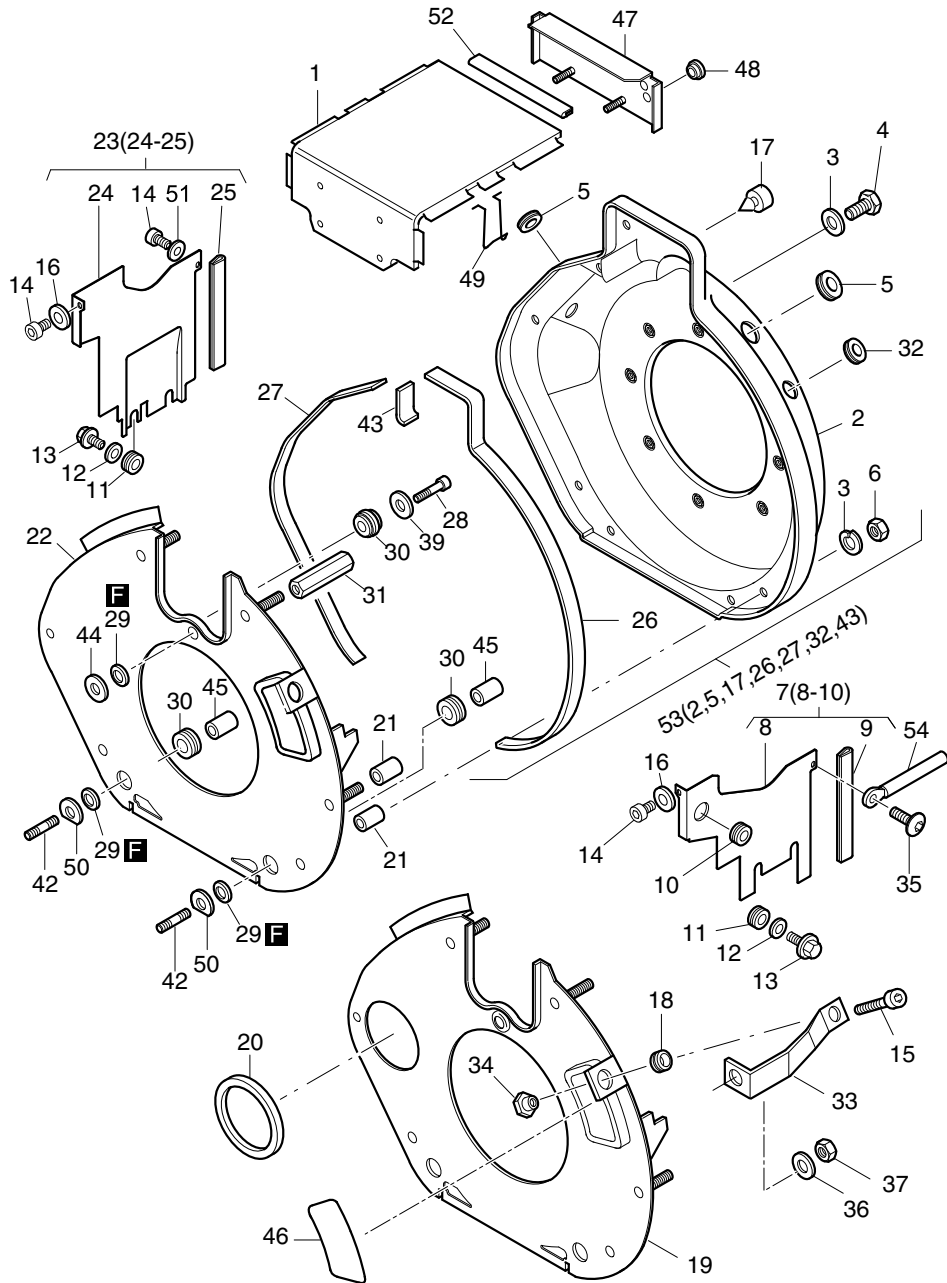

Fig.- No.	HATZ Ident-No.	Stück Qty.	W d / D	Bemerkungen Notes
		1B20V		
1	0000 015 335 04	1		
2	-----	-		
3	0000 501 709 00	7		6 DIN 128 - A3C
4	0000 501 463 00	1		M 6 x 18 DIN 933-8.8 A3C
5	0000 504 617 00	2		
6	0000 501 444 00	6		M 6 DIN 934 - 8 A3C
7	0000 013 166 00	1		
8	-----	-		
9	0000 040 976 00	1		107 mm
10	0000 503 348 00	1		
11	0000 501 638 01	4		
12	0000 504 416 00	3		4,3 DIN 9021 - A3C 140HV
13	0000 504 454 01	3		M 4 x 10 ST A3C
14	0000 505 281 00	3		M6x16DIN6912-8.8A3C KL360G
15	0000 501 707 00	1		M 6 x 16 DIN 912-8.8 A3C
16	0000 501 445 00	2		6,4 DIN 125-St A3C
17	0000 503 926 10	0... 2		
18	0000 503 928 00	1		
19	0000 016 070 11	1		E-Start
20	0000 040 995 00	1		
21	0000 041 390 00	5		6,5 x 12 x 18
22	0000 016 071 11	1		
23	0000 013 165 00	1		
24	-----	-		
25	0000 040 976 00	1		107 mm
26	0000 051 893 00	1		520 mm
27	0000 053 715 00	1		440 mm
28	0000 501 708 00	1		M 6 x 25 DIN 912 - 8.8 A3C
29	0000 035 755 00	3		
30	0000 013 783 00	3		
31	0000 041 244 00	1		57 mm
32	0000 504 533 00	1		
33	0000 015 995 00	1		
34	0000 041 232 00	1		M 6
35	0000 504 950 00	1		M 6 x 12 DIN 7380-10.9 A3C
36	0000 500 951 00	1		A 8 DIN 137 A3C
37	0000 503 447 00	1		M 8 DIN 936 - 5 A3C
39	0000 501 709 00	1		6 DIN 128 - A3C
42	0000 504 581 00	2		M 6 x 45 DIN 835 - 8.8 A3C
43	0000 050 073 00	1		48 mm
44	0000 040 420 00	1		6,5 x 22,5 x 1
45	0000 041 390 00	2		6,5 x 12 x 18
46	0000 042 151 00	0... 1		
47	0000 015 793 00	1		
48	0000 503 348 00	2		

M26a

Luftführung - 1B20V
 Air ducting - 1B20V
 Carter ventilation - 1B20V
 Conducción de aire - 1B20V
 Carter ventilatore - 1B20V

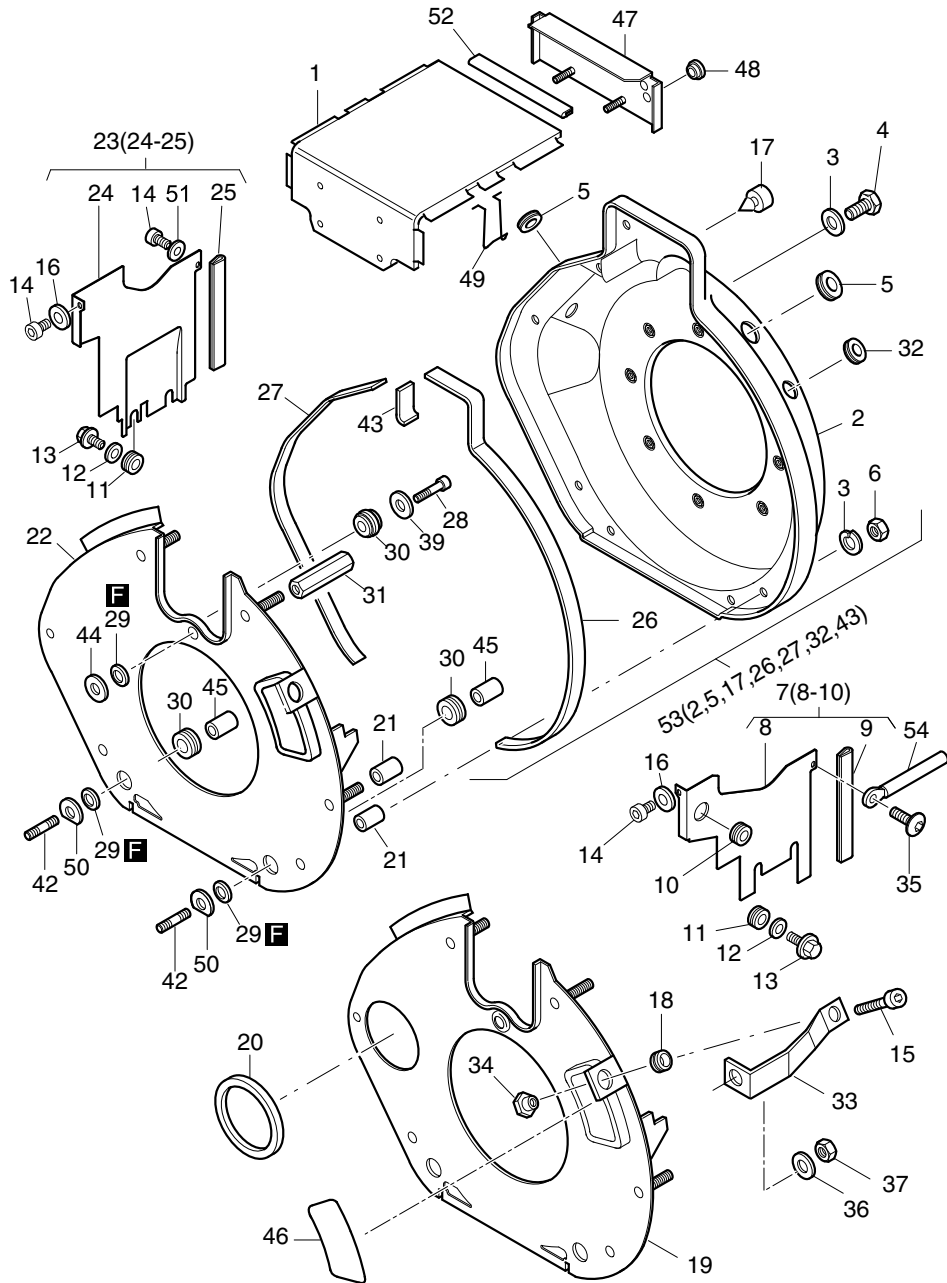

Fig.- No.	HATZ Ident-No.	Stück Qty.	W d / D	Bemerkungen Notes
		1B20V		
49	0000 051 441 00	1		
50	0000 041 453 00	2		
51	0000 040 606 00	1		6,4 x 16 x 1,5 A3C
52	0000 051 434 00	1		106mm
53	0000 018 311 00	1		
54	0000 050 012 00	1		

M26b

Luftführung - 1B30V
 Air ducting - 1B30V
 Carter ventilation - 1B30V
 Conducción de aire - 1B30V
 Carter ventilatore - 1B30V

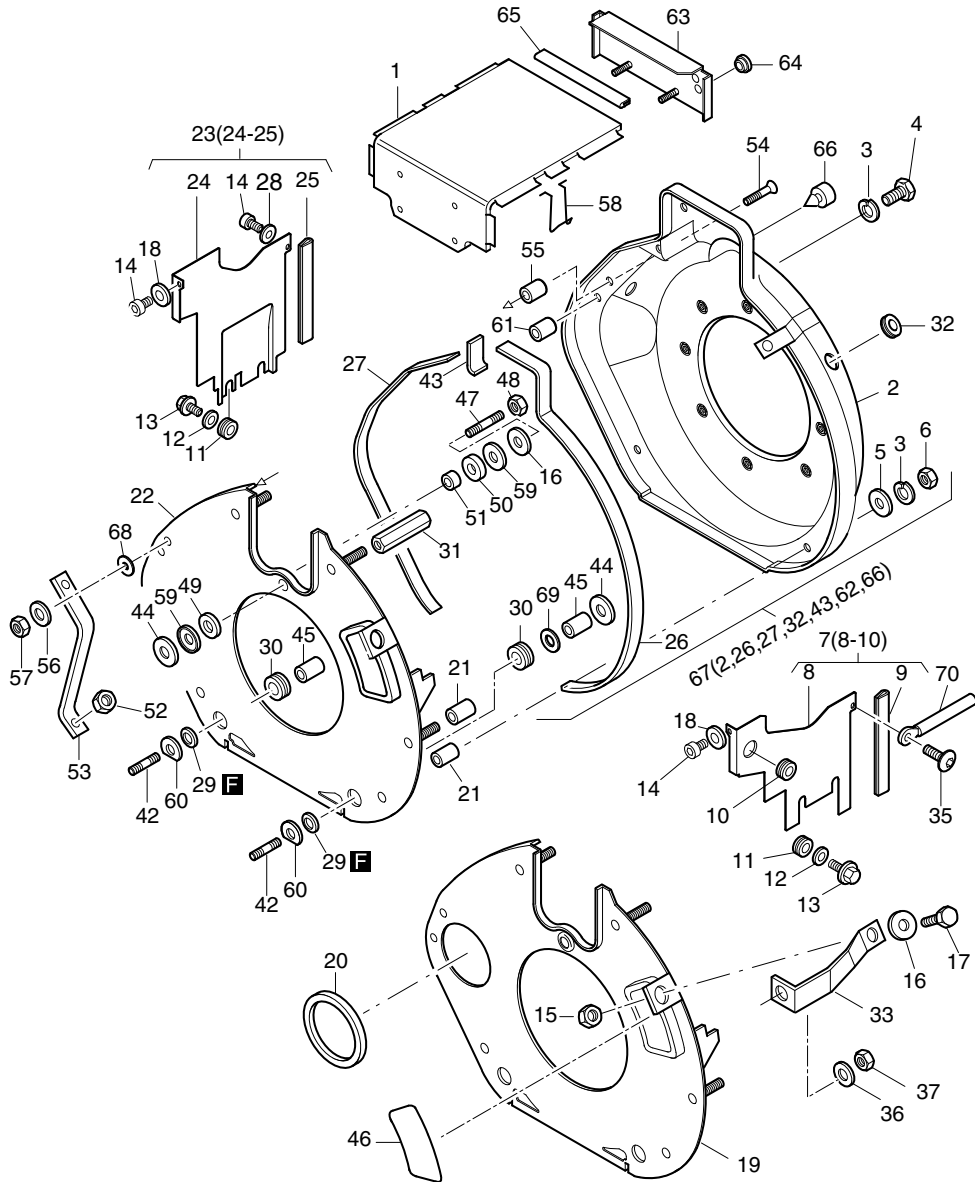

Fig.- No.	HATZ Ident-No.	Stück Qty.	W d / D	Bemerkungen Notes
		1B30V EPA IV		
1	0000 015 514 01	1		
2	-----	-		
3	0000 501 709 00	7		6 DIN 128 - A3C
4	0000 501 463 00	1		M 6 x 18 DIN 933-8.8 A3C
5	0000 501 200 00	2		A 6,4 DIN 9021-St A3C
6	0000 501 444 00	6		M 6 DIN 934 - 8 A3C
7	0000 013 263 00	1		
8	-----	-		
9	0000 051 289 00	1		80 mm
10	0000 503 348 00	1		
11	0000 501 638 01	3		
12	0000 504 416 00	3		4,3 DIN 9021 - A3C 140HV
13	0000 504 454 01	3		M 4 x 10 ST A3C
14	0000 505 281 00	3		M6x16DIN6912-8.8A3C KL360G
15	0000 501 444 00	1		M 6 DIN 934 - 8 A3C
16	0000 501 143 00	2		6,4 x 17 x 3 DIN 7349 A3C
17	0000 501 771 00	1		M 6 x 16 DIN 933-8.8 A3C
18	0000 501 445 00	2		6,4 DIN 125-St A3C
19	0000 013 268 10	1		E-Start
20	0000 040 995 00	1		
21	0000 051 975 00	4		6,5 x 12 x 20
22	0000 013 267 10	1		
23	0000 013 262 00	1		
24	-----	-		
25	0000 041 115 00	1		119 mm
26	0000 041 519 00	1		510mm
27	0000 041 519 00	1		510mm
28	0000 040 606 00	1		6,4 x 16 x 1,5 A3C
29	0000 035 755 00	2		
30	0000 013 783 00	2		
31	0000 051 981 00	1		59 mm
32	0000 504 533 00	1		
33	0000 015 996 10	1		
35	0000 504 950 00	1		M 6 x 12 DIN 7380-10.9 A3C
36	0000 500 951 00	1		A 8 DIN 137 A3C
37	0000 503 447 00	1		M 8 DIN 936 - 5 A3C
42	0000 504 581 00	2		M 6 x 45 DIN 835 - 8.8 A3C
43	0000 051 982 00	1		48 mm
44	0000 040 420 00	3		6,5 x 22,5 x 1
45	0000 040 984 00	2		7 x 12 x 16,3
46	0000 042 150 00	0... 1		
47	0000 504 644 01	1		M 6 x 35 DIN 939- 8.8 A3C Tuf.
48	0000 503 283 00	1		VM 6 DIN 980-8 A3C
49	0000 051 338 00	1		16 x 25 x 4
50	0000 051 339 00	1		16 x 25 x 8

M26b

Luftführung - 1B30V
 Air ducting - 1B30V
 Carter ventilation - 1B30V
 Conducción de aire - 1B30V
 Carter ventilatore - 1B30V

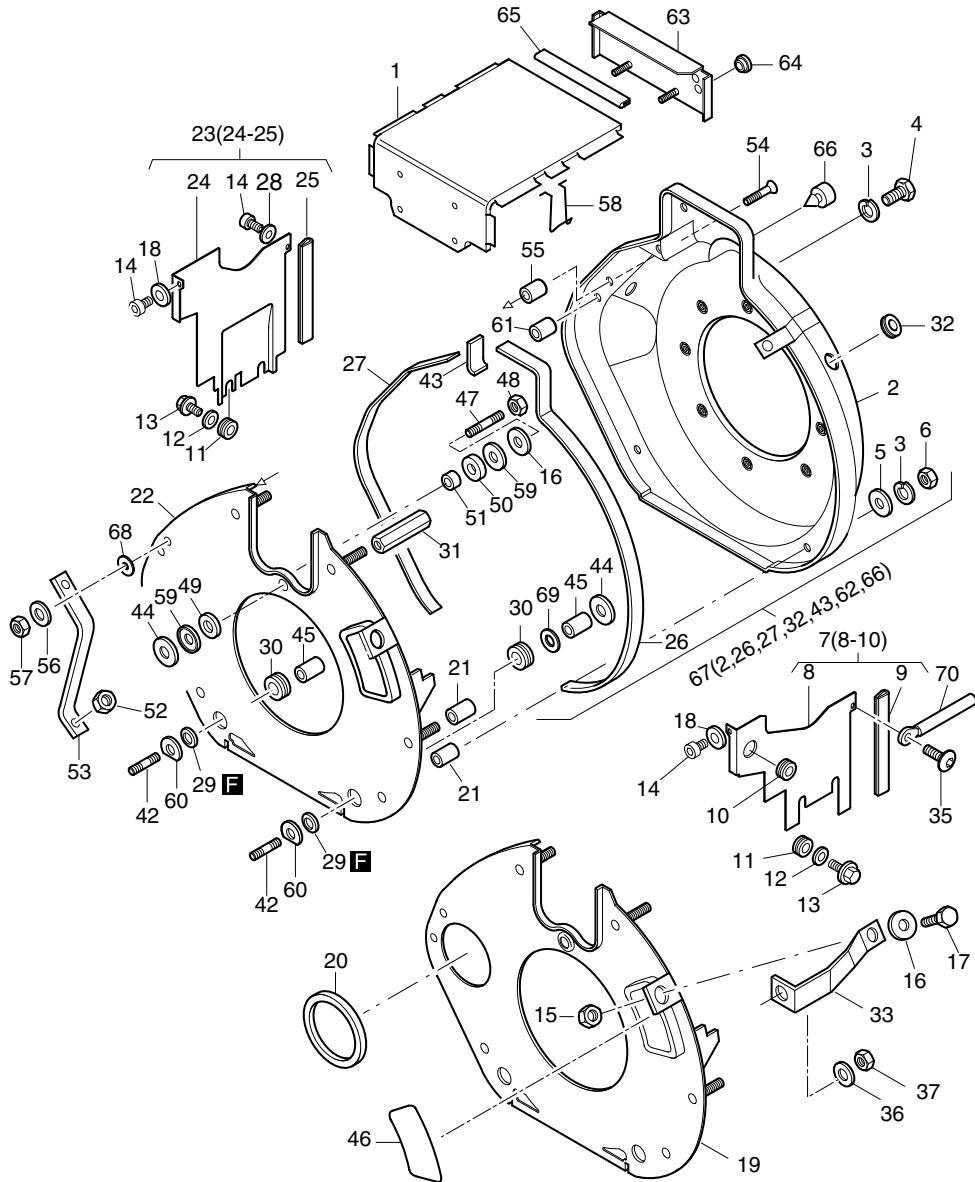

Fig.- No.	HATZ Ident-No.	Stück Qty.	W d / D	Bemerkungen Notes
		1B30V EPA IV		
51	0000 051 327 00	1		6,5 x 17 x 11,5
52	0000 501 480 00	1		M 8 DIN 934-8 A3C
53	0000 051 330 01	1		
54	0000 504 450 00	1		M 6 x 35 DIN 7991 - 8.8 A3C
55	0000 051 328 10	1		7 x 12 x 18,3
56	0000 501 709 00	1		6 DIN 128 - A3C
57	0000 501 444 00	1		M 6 DIN 934 - 8 A3C
58	0000 051 458 00	1		
59	0000 050 976 00	2		8,5 - 27
60	0000 041 453 00	2		
61	0000 041 390 00	1		6,5 x 12 x 18
63	0000 016 035 00	1		
64	0000 503 348 00	2		
65	0000 052 190 00	1		118mm
66	0000 503 926 10	0... 4		
67	0000 018 314 00	1		
68	0000 501 200 00	0... 1		A 6,4 DIN 9021-St A3C
69	0000 501 445 00	0... 2		6,4 DIN 125-St A3C
70	0000 050 012 00	1		

M31a

Kurbelgehäuseentlüftung - 1B20V
 Crankcase breathing system - 1B20V
 Reniflard - 1B20V
 Purgador - 1B20V
 Sfiato basamento - 1B20V

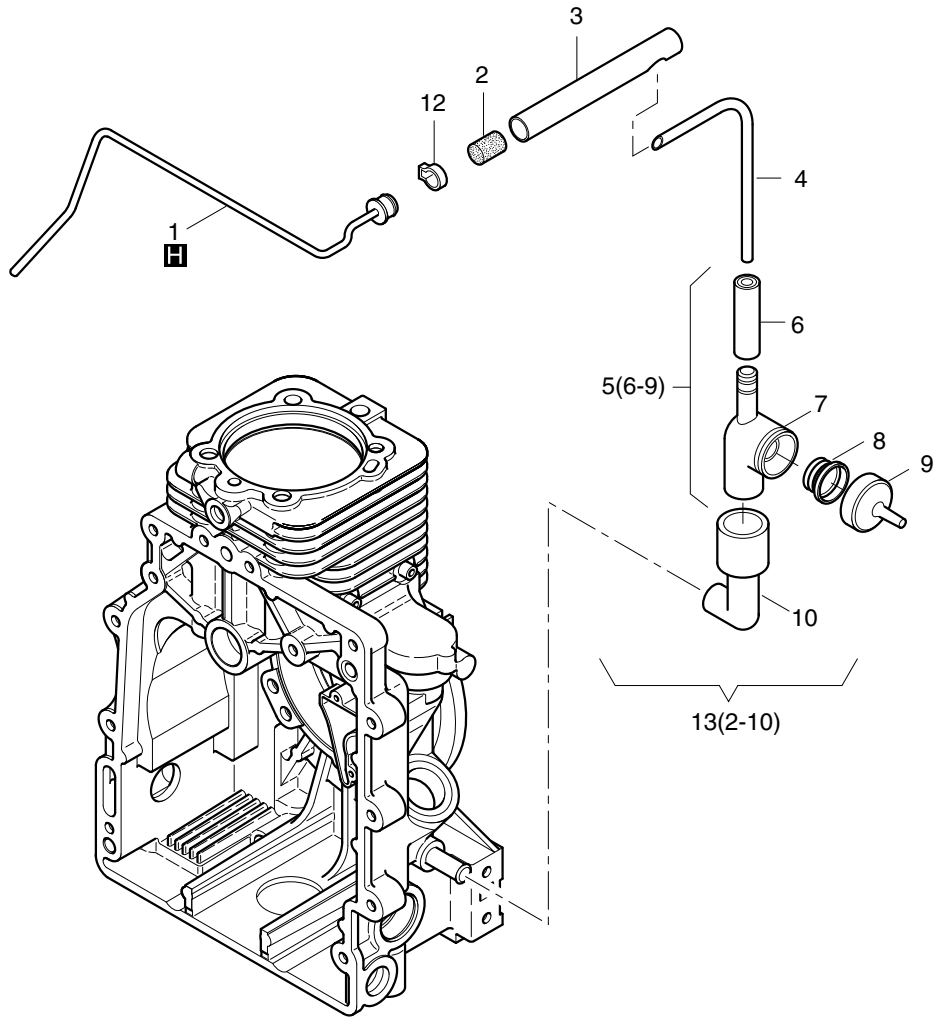

Fig.- No.	HATZ Ident-No.	Stück Qty.	W d / D	Bemerkungen Notes
		1B20V		
1	0000 013 391 00	1		
2	0000 051 029 00	1		Filter, Filtre, Filtro
3	0000 041 396 00	1		
4	0000 041 789 00	1		
5	0000 013 396 00	1		
6	0000 013 390 00	1		
7	-----	-		
8	0000 035 687 01	1		
9	0000 035 686 00	1		
10	0000 041 361 00	1		
12	0000 504 568 00	1		
13	0000 013 397 00	1		

M31b

Kurbelgehäuseentlüftung - 1B30V
 Crankcase breathing system - 1B30V
 Reniflard - 1B30V
 Purgador - 1B30V
 Sfiato basamento - 1B30V

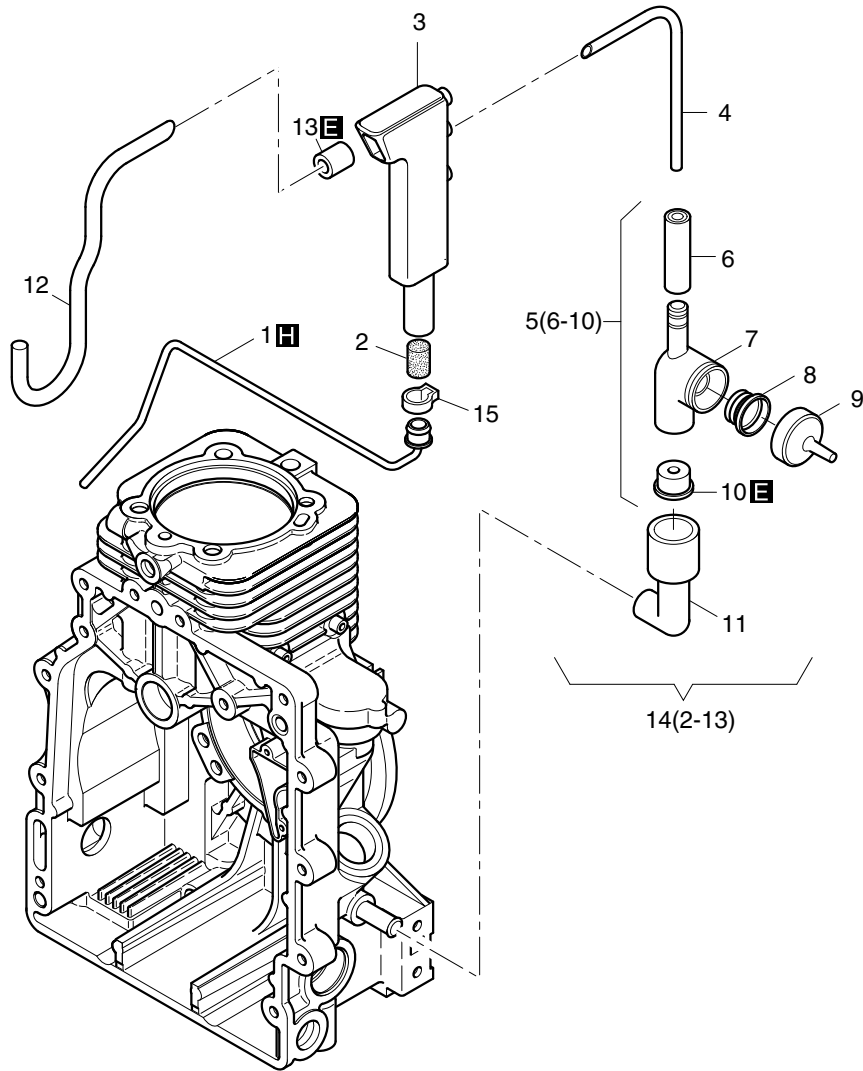

Fig.- No.	HATZ Ident-No.	Stück Qty.	W d / D	Bemerkungen Notes
		1B30V EPA IV		
1	0000 013 391 00	1		
2	0000 051 029 00	1		Filter, Filtre, Filtro
3	0000 041 708 00	1		
4	0000 041 789 00	1		
5	0000 013 541 00	1		
6	0000 013 390 00	1		
7	-----	-		
8	0000 035 687 01	1		
9	0000 035 686 00	1		
10	0000 041 788 00	1		
11	0000 041 361 00	1		
12	0000 042 610 00	1		
13	0000 042 595 00	1		
14	0000 013 540 01	1		
15	0000 504 568 00	1		

M31c

Kurbelgehäuseentlüftung - 1B30V
 Crankcase breathing system - 1B30V
 Reniflard - 1B30V
 Purgador - 1B30V
 Sfiato basamento - 1B30V

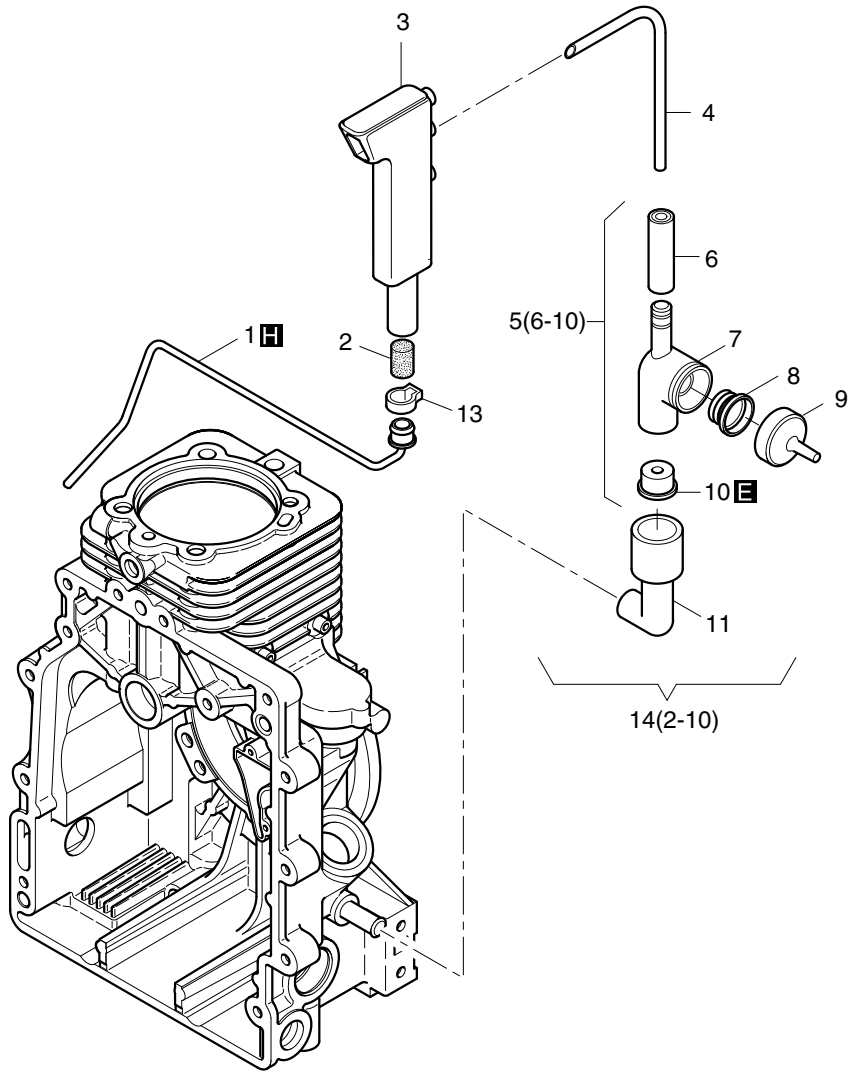

Fig.- No.	HATZ Ident-No.	Stück Qty.	W d / D	Bemerkungen Notes
		1B30V NON EPA		
1	0000 013 391 00	1		
2	0000 051 029 00	1		Filter, Filtre, Filtro
3	0000 041 708 00	1		
4	0000 041 789 00	1		
5	0000 013 541 00	1		
6	0000 013 390 00	1		
7	-----	-		
8	0000 035 687 01	1		
9	0000 035 686 00	1		
10	0000 041 788 00	1		
11	0000 041 361 00	1		
13	0000 504 568 00	1		
14	0000 019 310 00	1		

Z01

Kraftstoff
Fuel
Carburant
Combustible
Serbatoio

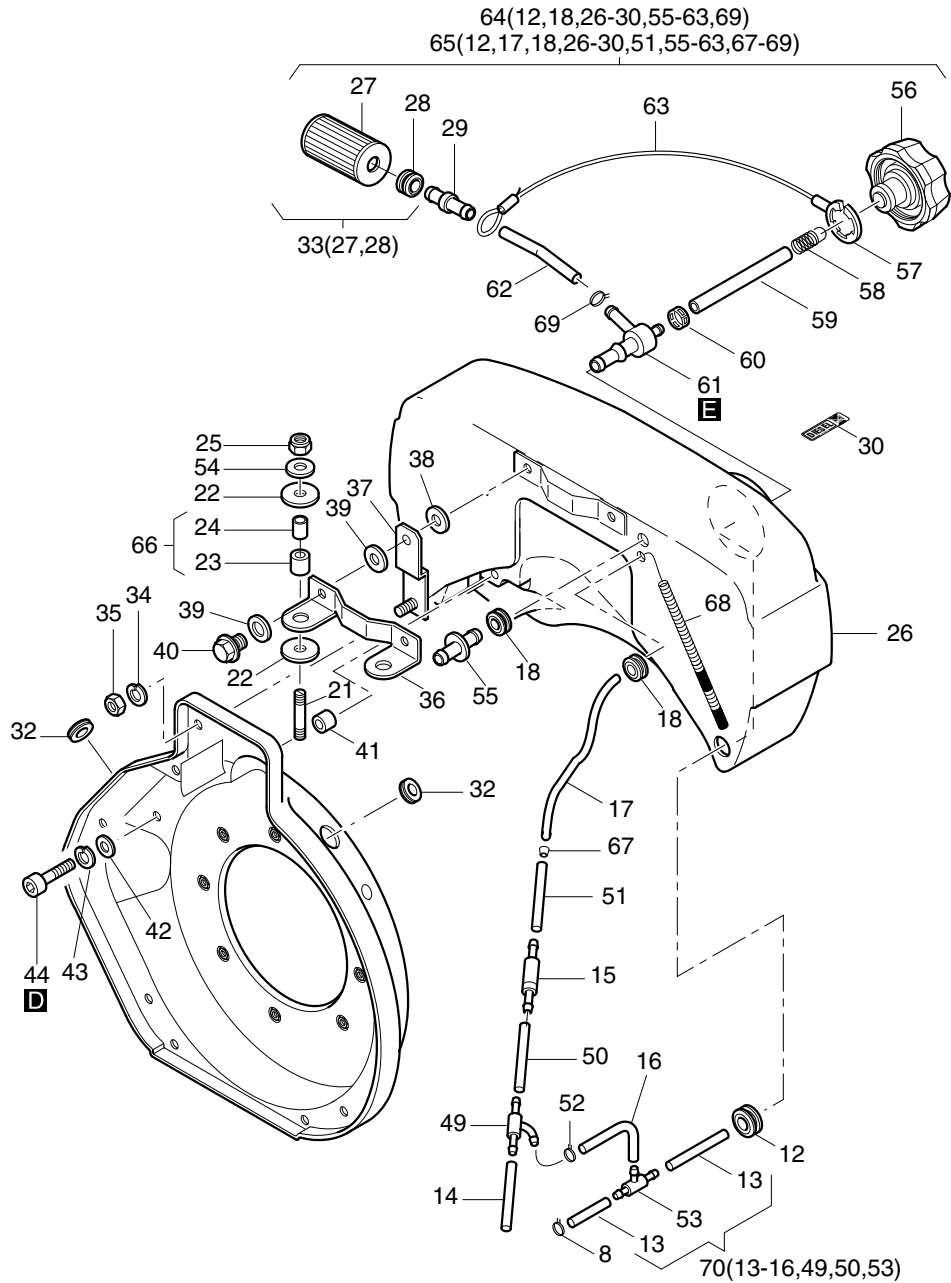

Fig.- No.	HATZ Ident-No.	Stück Qty.		W d / D	Bemerkungen Notes
		1B20V	1B30V EPA IV		
8	0000 504 411 00	1	1		11,8-505R
12	0000 504 408 00	1	1		
13	0000 051 231 00	2	2		7 x 70
14	0000 050 853 00	1	1		3,5 x 45
15	0000 015 346 01	1	1		
16	0000 053 277 00	1	1		5,0 x 170
17	0000 051 576 00	1	-		
17	0000 052 051 00	-	1		
18	0000 051 304 00	2	2		
21	0000 502 319 00	2	2		M 8 x 25 DIN 835-8.8 A3C
22	0000 051 098 10	4	4		8,2 x 22 x 2
23	-----	-	-		
24	0000 051 228 00	2	2		
25	0000 400 284 00	2	2		VM 8 DIN 980-8 C3A
26	-----	-	-		
27	-----	-	-		
28	0000 504 409 01	1	1		
29	0000 050 844 01	1	1		
30	0000 052 356 02	1	1		"DIESEL"
32	0000 051 077 00	2	-		
32	0000 504 533 00	-	1		
33	0000 016 352 00	1	1		W2
34	0000 501 709 00	2	2		6 DIN 128 - A3C
35	0000 501 444 00	2	2		M 6 DIN 934 - 8 A3C
36	0000 051 085 11	1	-		
36	0000 051 223 00	-	1		
37	0000 013 313 00	2	2		
38	0000 501 200 00	2	2		A 6,4 DIN 9021-St A3C
39	0000 051 100 10	4	4		7,1 x 17,9 x 2
40	0000 015 570 00	2	-		M 6 x 18
40	0000 016 771 00	-	2		M 6 x 20
41	0000 041 188 00	2	4		6,5 x 13 x 4,8
42	0000 501 445 00	2	4		6,4 DIN 125-St A3C
43	0000 501 709 00	2	4		6 DIN 128 - A3C
44	0000 501 707 00	2	4		M 6 x 16 DIN 912-8.8 A3C
49	0000 051 227 01	1	1		
50	0000 051 232 00	1	1		3,5 x 40
51	0000 053 291 00	1	-		5,0 x 75
51	0000 040 604 10	-	1		5 x 100
52	0000 503 998 01	1	1		11,3
53	0000 504 596 00	1	1		
54	0000 501 481 00	2	2		8,4 DIN 125-St A3C
55	0000 051 296 10	1	1		
56	0000 016 203 03	1	1		
57	0000 504 800 00	1	1		20 x 1 DIN 984

Kraftstoff
 Fuel
 Carburant
 Combustible
 Serbatoio

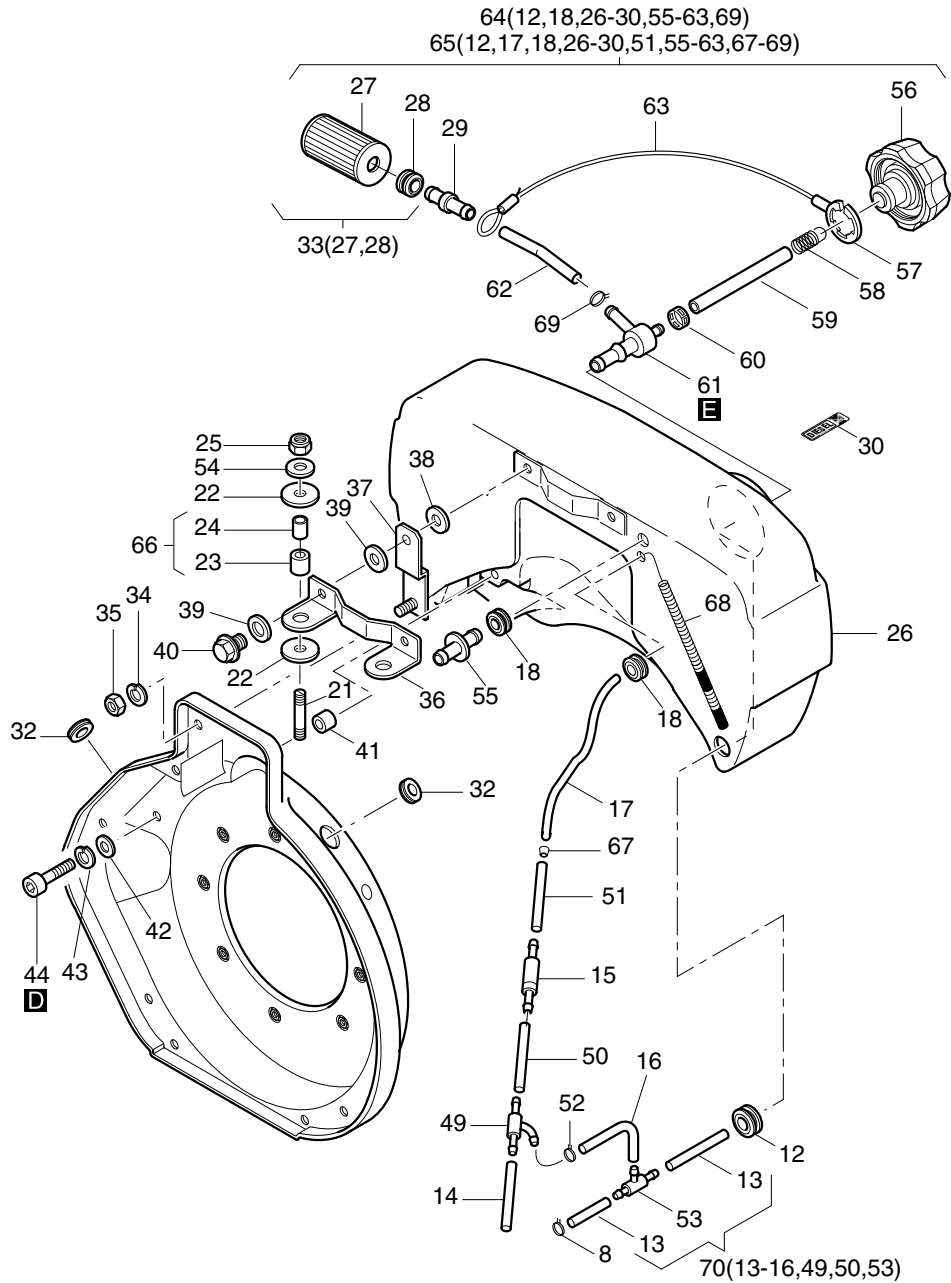

Fig.- No.	HATZ Ident-No.	Stück Qty.		W d / D	Bemerkungen Notes
		1B20V	1B30V EPA IV		
58	0000 504 792 00	1	1		
59	0000 053 366 00	1	-		
59	0000 051 903 00	-	1		
60	0000 504 801 00	1	1		
61	0000 016 239 10	1	1		
62	0000 053 402 00	1	-		
62	0000 053 421 00	-	1		7 x 280 mm
63	0000 016 289 00	1	1		~440mm
64	0000 016 242 00	1	-		3l
65	0000 017 018 00	-	1		5l
66	0000 016 558 00	2	2		
67	0000 051 265 00	-	1		
68	0000 016 485 00	-	1		160mm
69	0000 505 112 01	1	1		14,5
70	0000 015 791 00	1	1		

Luftfilter
Air filter
Filtre à air
Filtro de aire
Filtro aria

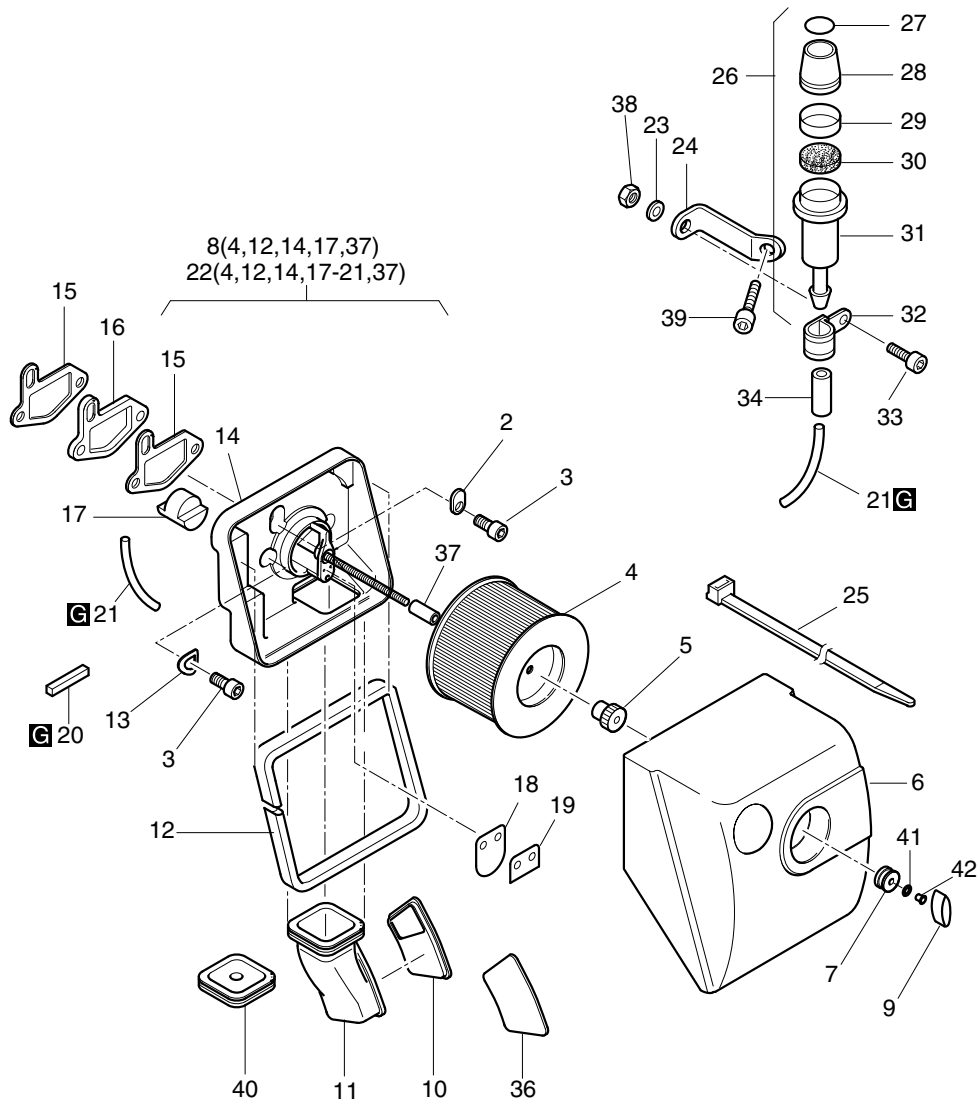

Fig.- No.	HATZ Ident-No.	Stück Qty.		W d / D	Bemerkungen Notes
		1B20V	1B30V EPA IV		
2	0000 050 564 00	1	1		
3	0000 501 715 00	3	3		M 8 x 25 DIN 912-8.8 A3C
4	0000 504 260 00	1	1		W2
5	0000 504 543 00	1	1		M 6
6	0000 016 991 01	1	-		
6	0000 016 993 01	-	1		
7	0000 504 358 00	1	1		
8	0000 016 079 01	1	-		
8	0000 016 079 10	-	1		
9	0000 504 522 00	1	1		M 6
10	0000 041 042 00	0...1	-		
10	0000 041 166 00	-	0...1		
11	0000 041 030 00	0...1	-		
11	0000 041 165 01	-	0...1		
12	0000 052 161 00	1	1		545 mm
13	0000 500 951 00	2	2		A 8 DIN 137 A3C
14	-----	-	-		
15	0000 050 563 00	2	2		d2
16	0000 016 003 00	1	1		
17	0000 050 981 00	1	1		
18	0000 051 471 00	1	-		(schwarz, black, noir)
19	0000 051 472 00	1	-		(rot, red, rouge)
20	0000 051 750 00	1	-		14 x 9 x 30
21	0000 050 446 10	1	-		2 x 4 x 135
22	0000 016 302 01	1	-		f. Pos 26
22	0000 016 302 10	-	1		f. Pos 26
23	0000 501 709 00	1	-		6 DIN 128 - A3C
24	0000 051 646 00	1	-		
25	0000 503 584 00	1	-		200 x 4,8 mm
26	0000 014 998 01	1	-		(Pos 27-31)
27	0000 050 445 01	1	-		
28	0000 050 436 01	1	-		
29	0000 050 456 00	1	-		(grün, green, vert, verde)
30	0000 051 372 00	1	-		Filter, Filtre, Filtro ø 20 mm
31	0000 050 437 00	1	-		
32	0000 501 735 00	1	-		10 / 15
33	0000 501 707 00	1	-		M 6 x 16 DIN 912-8.8 A3C
34	0000 039 177 00	1	-		3,5 x 140
36	0000 042 151 00	0...1	-		
36	0000 042 150 00	-	0...1		
37	0000 051 662 00	1	1		32 mm
38	0000 501 444 00	1	-		M 6 DIN 934 - 8 A3C
39	0000 501 706 00	1	-		M 6 x 20 DIN 912-8.8 A3C
40	0000 050 565 00	0...1	0...1		
41	0000 505 915 00	1	1		9 x 15 x 1,0 DIN 988
42	0000 505 916 00	1	1		8 x 0,5 x 12 DIN 7340

Z03a

Abgasdämpfer - 1B20V
 Exhaust silencer - 1B20V
 Silencieux - 1B20V
 Silenciador - 1B20V
 Marmitta - 1B20V

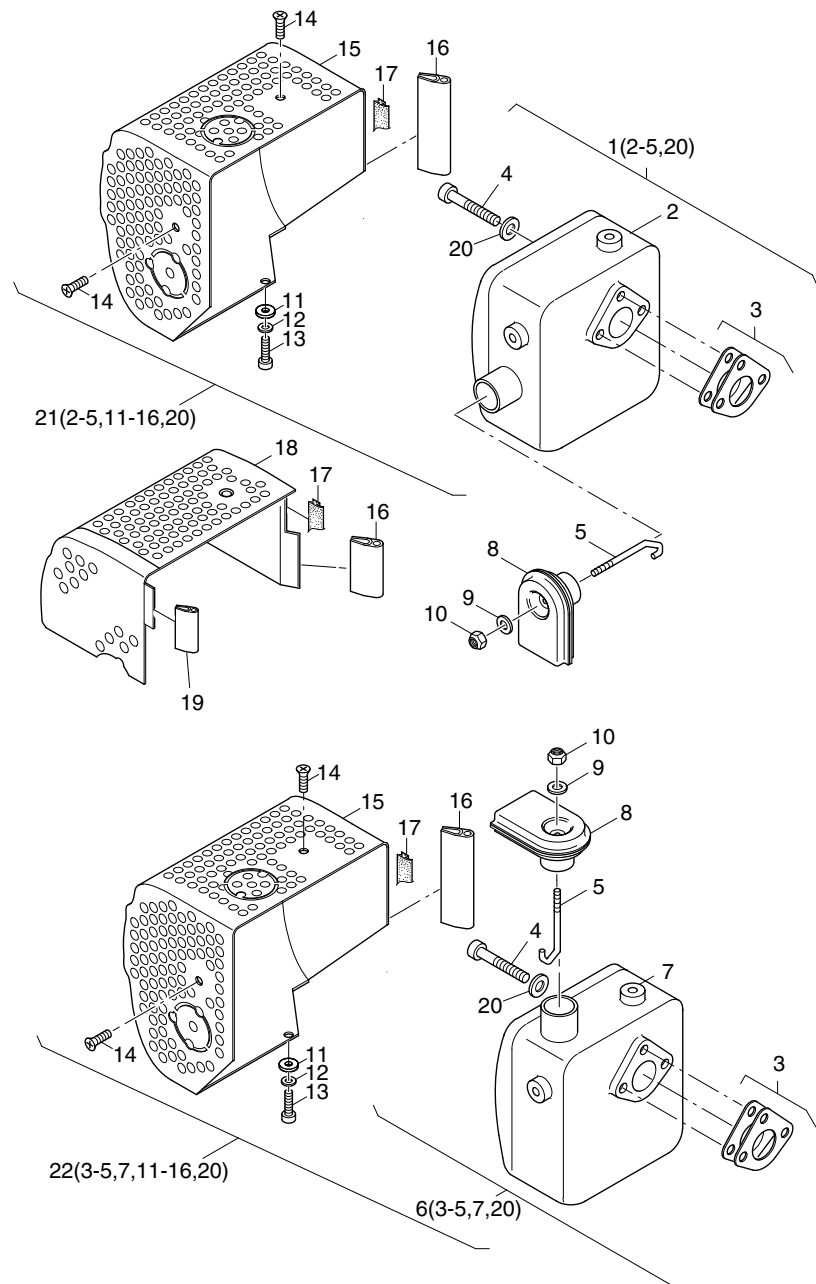

Fig.- No.	HATZ Ident-No.	Stück Qty.	W d / D	Bemerkungen Notes
1B20V				
1	0000 019 538 00	1		
2	-----	-		
3	0000 017 325 01	1		d1
4	0000 504 039 00	3		M 8 x 25 DIN 912-8.8 C4P
5	0000 051 779 00	1		M 6
6	0000 019 539 00	1		
7	-----	-		
8	0000 015 313 14	1		
9	0000 501 445 00	1		6,4 DIN 125-St A3C
10	0000 400 283 00	1		VM 6 DIN 980 C3P
11	0000 501 143 00	1		6,4 x 17 x 3 DIN 7349 A3C
12	0000 501 709 00	1		6 DIN 128 - A3C
13	0000 501 771 00	1		M 6 x 16 DIN 933-8.8 A3C
14	0000 504 225 01	2		M 6 x 12 DIN 7991 - 8.8 A3C
15	0000 018 702 03	1		
16	0000 051 003 00	1		65 mm
17	0000 051 350 00	1		33 mm
18	0000 015 906 01	1		STAMPFER - RAMMER
19	0000 041 234 00	1		38 mm
20	0000 502 085 00	3		8 DIN 128 A3C
21	0000 019 645 00	1		
22	0000 019 646 00	1		

Z03b

Abgasdämpfer - 1B30V
 Exhaust silencer - 1B30V
 Silencieux - 1B30V
 Silenciador - 1B30V
 Marmitta - 1B30V

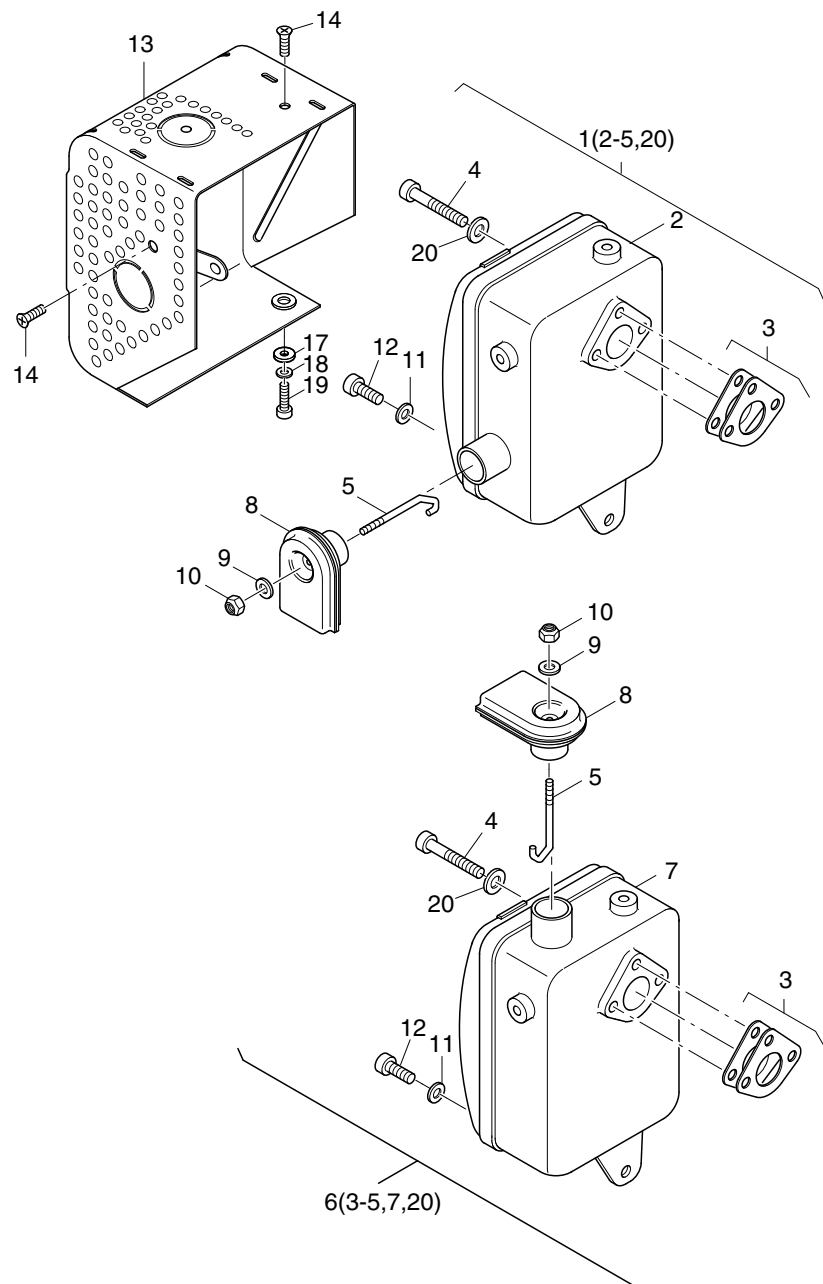

Fig.- No.	HATZ Ident-No.	Stück Qty.	W d / D	Bemerkungen Notes
		1B30V EPA IV		
1	0000 016 858 10	1		
2	-----	-		
3	0000 017 326 01	1		d1
4	0000 504 039 00	3		M 8 x 25 DIN 912-8.8 C4P
5	0000 051 779 00	1		M 6
6	0000 017 126 10	1		
7	-----	-		
8	0000 015 313 14	1		
9	0000 501 445 00	1		6,4 DIN 125-St A3C
10	0000 400 283 00	1		VM 6 DIN 980 C3P
11	0000 501 143 00	1		6,4 x 17 x 3 DIN 7349 A3C
12	0000 504 742 00	1		M6x16 DIN912-8.8 A3C Tuf.360
13	0000 016 457 03	1		
14	0000 504 225 01	2		M 6 x 12 DIN 7991 - 8.8 A3C
17	0000 501 143 00	1		6,4 x 17 x 3 DIN 7349 A3C
18	0000 501 709 00	1		6 DIN 128 - A3C
19	0000 501 771 00	1		M 6 x 16 DIN 933-8.8 A3C
20	0000 502 085 00	3		8 DIN 128 A3C

Z05a

Starter, Generator
 Starter, alternator
 Démarreur, alternateur
 Arrancador, alternador
 Motorino avviamento, alternatore

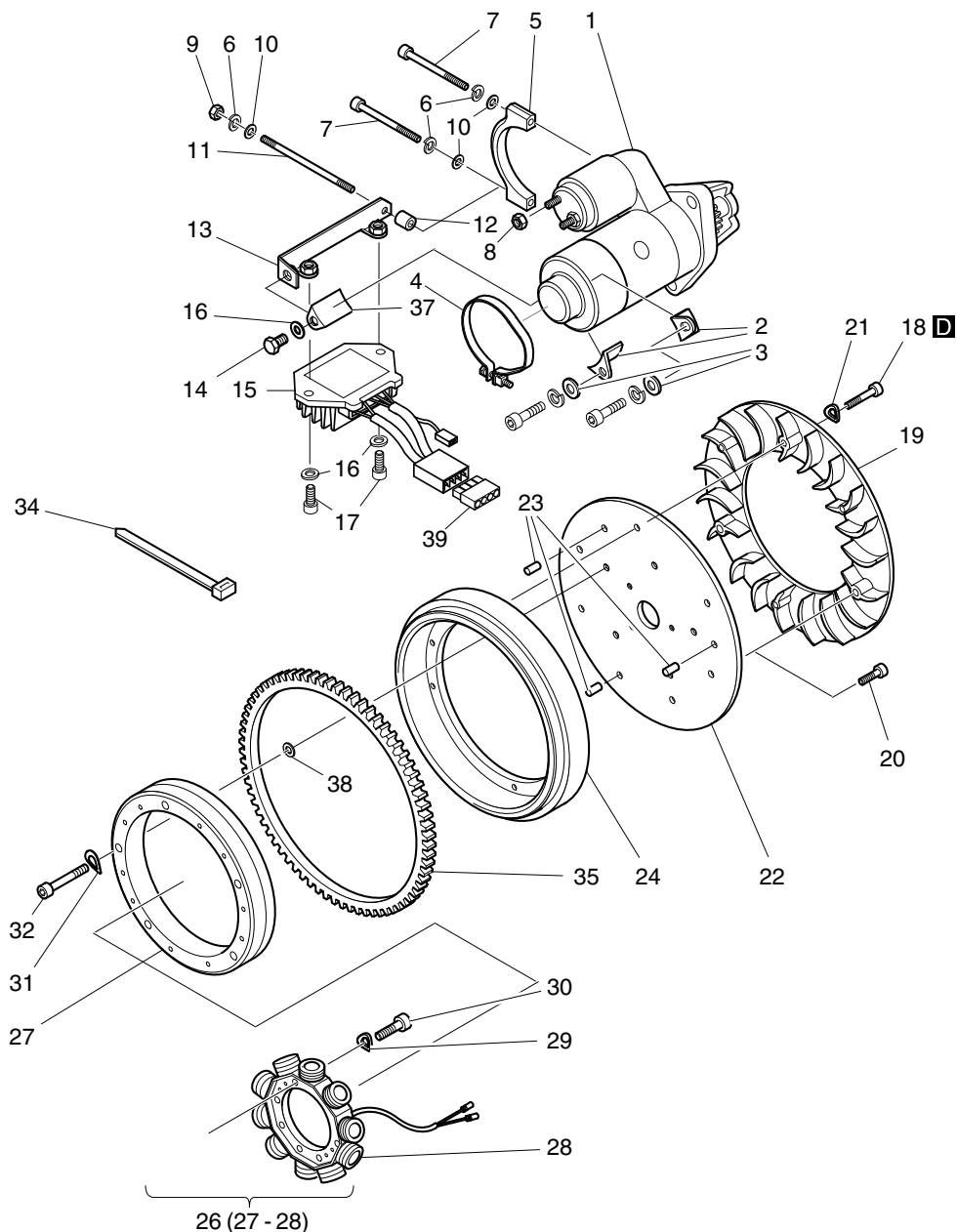

Fig.- No.	HATZ Ident-No.	Stück Qty.		W d / D	Bemerkungen Notes
		1B20V	1B30V EPA IV		
1	0000 017 234 00	1	1		12 V - 1,0 kW
1	0000 504 833 00	1	1		24 V - 1,6 kW
2	0000 041 384 00	2	2		
3	0000 501 481 00	2	2		8,4 DIN 125-St A3C
4	0000 505 298 00	1	1		
5	0000 040 991 00	1	1		
6	0000 501 709 00	2	2		6 DIN 128 - A3C
7	0000 504 443 00	2	2		M 6 x 80 DIN 912 - 8.8 A3C
8	0000 503 447 00	1	1		M 8 DIN 936 - 5 A3C
9	0000 501 444 00	1	1		M 6 DIN 934 - 8 A3C
10	0000 501 445 00	2	2		6,4 DIN 125-St A3C
11	0000 504 559 00	1	1		MFS 6x90 DIN 949 - 1 8.8 A3C
12	0000 036 714 00	1	1		7 x 12 x 15
13	0000 015 609 00	1	1		
14	0000 500 962 00	1	1		M 8 x 12 DIN 933 - 8.8 A3C
15	0000 019 838 00	1	1		12 V
15	0000 019 839 00	1	1		24 V
16	0000 501 481 00	3	3		8,4 DIN 125-St A3C
17	0000 501 830 00	2	2		M 8 x 35 DIN 912-8.8 A3C
18	0000 503 273 00	6	6		M 4 x 20 DIN 912 - 8.8 A3C
19	0000 041 937 00	1	-		
19	0000 041 936 00	-	1		
20	0000 504 168 00	3	3		M 6 x 16 DIN 912 - 8.8 A3C Tuf.
21	0000 500 034 00	6	6		A 4 DIN 137 - ST
22	0000 040 987 20	1	1		
23	0000 500 352 00	3	3		6 x 12 ISO 8752-ST
24	0000 040 982 30	1	-		
24	0000 041 101 20	-	1		
26	0000 019 259 00	1	1		12 V
26	0000 019 260 00	1	1		24 V / 12V o. BATT.
27	-----	-	-		
28	-----	-	-		
29	0000 500 819 00	4	4		A 5 DIN 137 A3C
30	0000 505 470 00	4	4		M 5 x 25 DIN 912 - 8.8 A3C Tuf.
31	0000 500 812 00	5	5		A 6 DIN 137 - A3C
32	0000 504 487 00	5	5		M 6 x 30 DIN 6912-8.8 A3C
34	0000 503 584 00	3	3		200 x 4,8 mm
35	0000 040 986 00	1	-		
35	0000 041 080 00	-	1		
37	0000 041 384 00	1	1		
38	0000 501 143 00	5	5		6,4 x 17 x 3 DIN 7349 A3C
39	0000 504 021 00	1	1		4-P.

Z05b, Z10, Z11 Armaturenkasten, Leitungen
 Electric equipment, wirings
 Equipement électrique, cable
 Cuadro de mando, cables
 Cruscotto, cablaggio

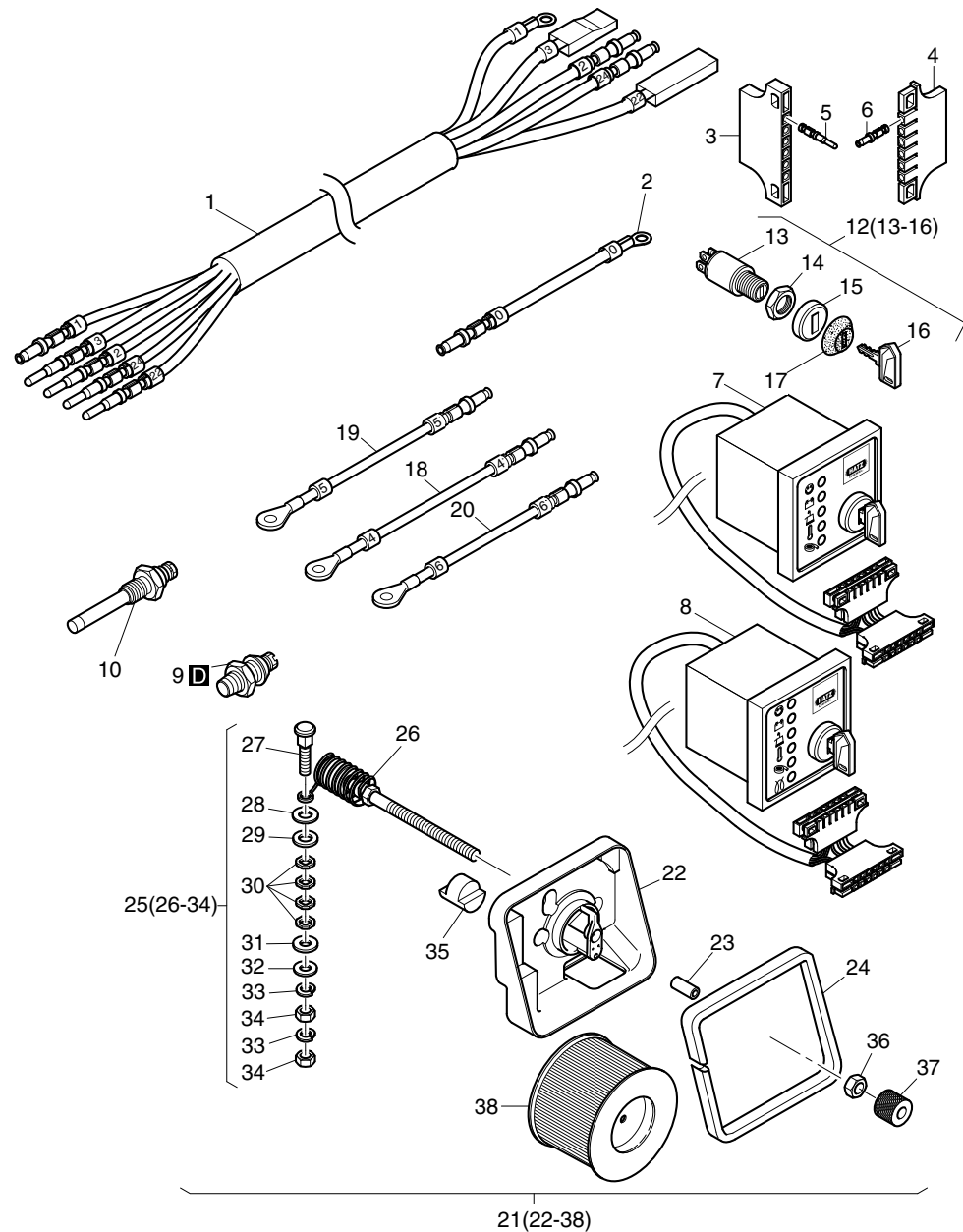

Fig.- No.	HATZ Ident-No.	Stück Qty.		W d / D	Bemerkungen Notes
		1B20V	1B30V EPA IV		
1	0000 015 422 00	1	1		
2	0000 015 483 00	1	1		(0)
3	0000 503 736 00	1	1		
4	0000 503 737 00	1	1		
5	0000 503 741 00	5	5		0,5 - 1,0
6	0000 503 739 00	6	6		1,5 - 2,5
7	0000 015 518 02	1	1		12 V, A 1
8	0000 015 589 01	1	1		12 V / 24 V, Aut.
9	0000 400 213 00	0... 1	-		12 - 24V Oil 0,5 - 0,8 bar
9	0000 504 691 00	-	0... 1		OIL 0,3 - 0,6 bar
9	0000 506 044 00	0... 1	0... 1		1,20 - 1,80 bar (Gen)
10	0000 502 686 00	1	1		TEMP. 12-24V
12	0000 503 844 01	1	1		
13	-----	-	-		
14	-----	-	-		
15	-----	-	-		
16	0000 504 049 00	1	1		Nr. 14644
17	0000 051 264 02	1	1		
18	0000 015 480 00	1	1		(4) 500 mm
19	0000 015 481 00	1	1		(5) 470 mm
20	0000 017 153 00	1	1		(6) 430 mm
21	0000 016 078 10	1	-		12V
21	0000 017 454 00	1	-		24V
21	0000 016 078 20	-	1		12V
21	0000 017 454 10	-	1		24V
22	-----	-	-		
23	0000 041 192 00	1	1		6,5 x 13 x 15
24	0000 052 161 00	1	1		545 mm
25	0000 017 550 00	1	1		12V
25	0000 017 551 00	1	1		24V
26	-----	-	-		
27	0000 050 401 00	1	1		
28	0000 501 445 00	1	1		6,4 DIN 125-St A3C
29	0000 504 128 01	1	1		6,5
30	0000 504 126 00	4	4		
31	0000 504 127 00	1	1		
32	0000 502 163 00	1	1		5,3 DIN 125-St A3C
33	0000 500 026 00	2	2		5 DIN 128 - A3C
34	0000 500 943 00	2	2		M 5 DIN 934-8 A3C
35	0000 050 981 00	1	1		
36	0000 501 444 00	1	1		M 6 DIN 934 - 8 A3C
37	0000 051 496 00	1	1		12 mm
38	0000 504 260 00	1	1		

Z09a

Drehzahlverstellung Bowdenzug
 Speed control - bowdencable
 Reglage regime - bowden
 Ajuste de revoluciones - bowden
 Comando acceleratore - bowden

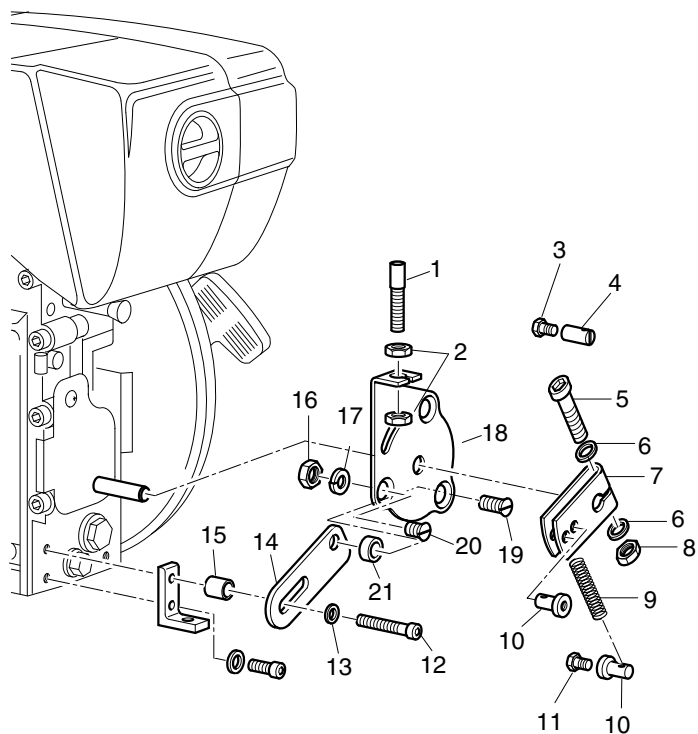
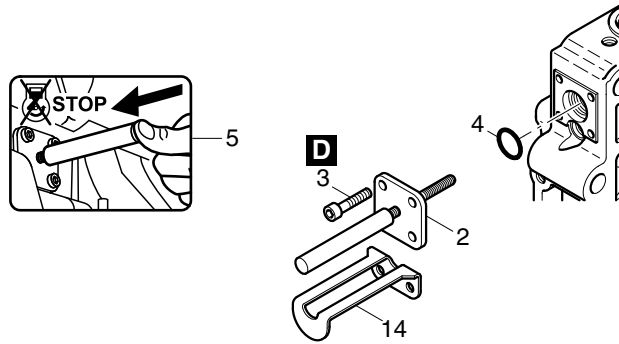

Fig.- No.	HATZ Ident-No.	Stück Qty.		W d / D	Bemerkungen Notes
		1B20V	1B30V EPA IV		
1	0000 051 412 00	1	1		M 6
2	0000 501 444 00	2	2		M 6 DIN 934 - 8 A3C
3	0000 500 250 00	1	1		M 4 x 10 DIN 933-8.8 A3C
4	0000 504 830 00	1	1		2,2 NR. 1120
5	0000 505 119 00	1	1		M 5 x 30 DIN 912 - 8.8 A3C
6	0000 502 163 00	2	2		5,3 DIN 125-St A3C
7	0000 051 177 00	1	1		
8	0000 500 943 00	1	1		M 5 DIN 934-8 A3C
9	0000 504 846 00	1	1		VD-179 E
10	0000 504 831 00	2	2		2,2 NR. 1450
11	0000 500 250 00	1	1		M 4 x 10 DIN 933-8.8 A3C
12	0000 502 488 00	1	1		M 8 x 60 DIN 912 - 8.8 A3C
13	0000 501 481 00	1	1		8,4 DIN 125-St A3C
14	0000 051 175 00	1	1		
15	0000 041 785 00	1	1		9 x 14 x 27
16	0000 503 283 00	1	1		VM 6 DIN 980-8 A3C
17	0000 502 085 00	1	1		8 DIN 128 A3C
18	0000 051 176 10	1	1		
19	0000 504 239 00	1	1		M 6 x 20 DIN 7991-10.9 A3C
20	0000 503 808 00	1	1		M 6 x 10 DIN 7991 -8.8 A3C
21	0000 032 929 00	1	1		8,2 x 11 x 12

Z09b

Motorabstellvorrichtung
 Engine stop device
 Dispositif d'arret
 Dispositivo de parado
 Dispositivo di arresta



1(2-5)

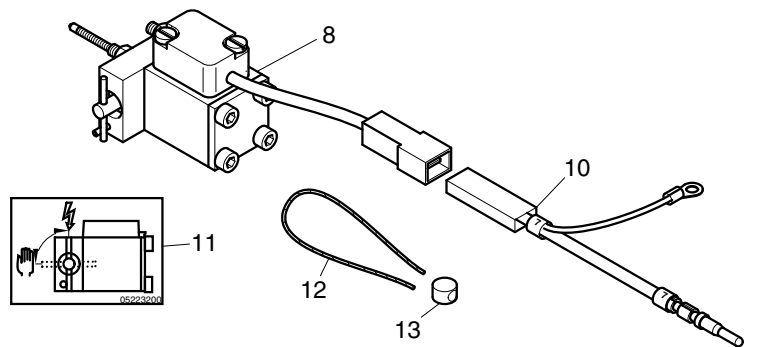

7(8,10-13)

Fig.- No.	HATZ Ident-No.	Stück Qty.		W d / D	Bemerkungen Notes
		1B20V	1B30V EPA IV		
1	0000 017 864 01	1	1		
2	-----	-	-		
3	0000 504 469 00	4	4		M 4 x 16 DIN 912-8.8 A3C Tuf.
4	0000 503 290 00	1	1		9,5 x 2,5
5	0000 052 213 01	1	1		Hinweisschild
7	0000 017 861 01	1	1		12V
7	0000 017 863 01	1	1		24V
8	-----	-	-		
10	0000 015 482 01	1	1		
11	0000 052 232 00	1	1		
12	0000 400 215 00	1	1		0,5 / 0,3 x 200
13	0000 400 214 00	1	1		8 mm ø
14	0000 053 072 00	1	1		

Z18

Anbauteile Hydraulikpumpe
 Mount. parts hydr. pump
 Pièces mont. -pompe hydr.
 Piezas mont. bomba hidr.
 Particolari per montaggio pompa idraulica

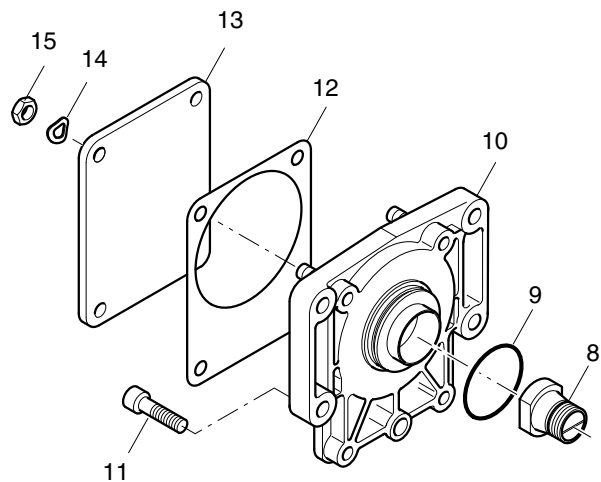
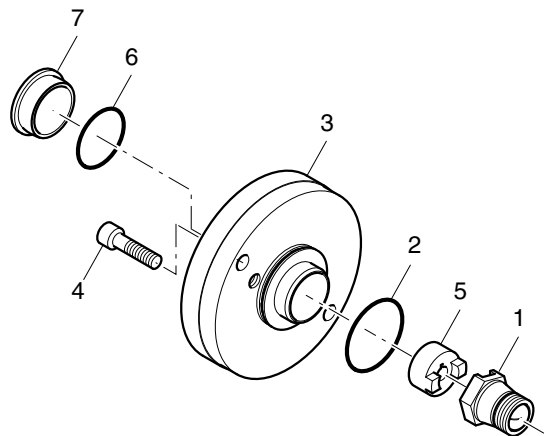

Fig.- No.	HATZ Ident-No.	Stück Qty.		W d / D	Bemerkungen Notes
		1B20V	1B30V EPA IV		
1	0000 015 581 00	1	1		
2	0000 504 545 00	1	1		44 x 1,5
3	0000 051 150 00	1	1		
4	0000 501 759 00	2	2		M 8 x 30 DIN 912-8.8 A3C
5	0000 051 147 00	1	1		
6	0000 502 882 00	1	1		32 x 2,5
7	0000 501 631 01	1	1		F 25 ø 31,8
8	0000 015 580 00	1	1		
9	0000 504 545 00	1	1		44 x 1,5
10	0000 016 648 00	1	1		
11	0000 504 943 00	4	4		M 8 x 20 DIN 912-8.8 Tuf.
12	0000 035 680 00	1	1		
13	0000 037 616 00	1	1		
14	0000 500 951 00	4	4		A 8 DIN 137 A3C
15	0000 501 480 00	4	4		M 8 DIN 934-8 A3C

Z25

Autom. Ventilspielnachsteller
 Autom. valve adjuster
 Correcteur automatique du jeu de soupape
 Ajuste automatico luz de valvulas
 Regolazione automatica valvole

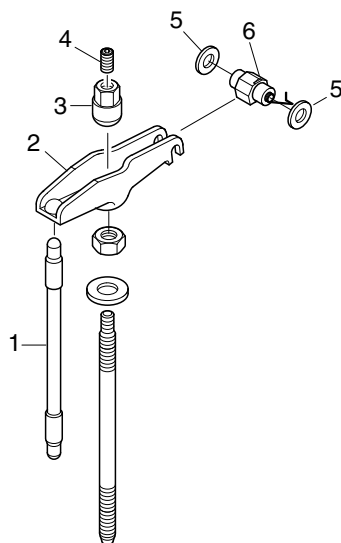

Fig.- No.	HATZ Ident-No.	Stück Qty.		W d / D	Bemerkungen Notes
		1B20V	1B30V EPA IV		
1	0000 013 742 01	2	-		
1	0000 013 741 01	-	2		
2	0000 050 509 02	2	-		
2	0000 052 835 00	-	2		
3	0000 050 547 00	2	2		
4	0000 505 131 00	2	2		
5	0000 052 407 00	0... 4	0... 4		W2 M 8 x 10 DIN 916 - 45 H
5	0000 504 451 00	0... 4	0... 4		6 x 12 x 1,35
6	0000 017 760 00	2	2		6 x 12 x 1,2 DIN 988

Motorausrüstung EPA
 Spec. equipment EPA
 Equipm. spec. EPA
 Equipo espec. EPA
 Kit trasformazione EPA

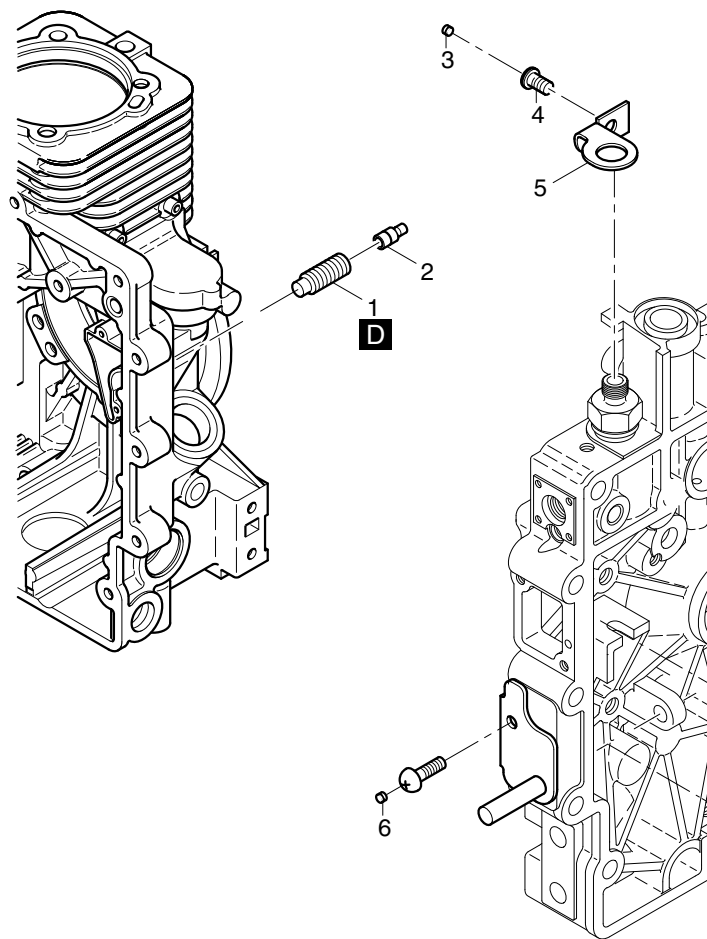

Fig.- No.	HATZ Ident-No.	Stück Qty.	W d / D	Bemerkungen Notes
		1B30V EPA IV		
1	0000 041 987 00	1		
2	0000 041 505 00	1		6
3	0000 041 706 00	2		4,15
4	0000 504 950 00	1		M 6 x 12 DIN 7380-10.9 A3C
5	0000 041 853 01	1		
6	0000 052 015 00	1		3



HATZ service network

A	Austria	2320 Schwechat - Rannersdorf	Josef Hofmann GmbH.	+43 - 1 - 7 07 06 08
A	Austria	4600 Wels	Motor Center Austria GmbH	+43 - 7242 - 4 71 61-0
A	Austria	5020 Salzburg	Ing. R. Schneider	+43 - 662 - 87 23 54
A	Austria	6065 Thaur	Romed Müssigang	+43 - 5223 - 49 28 34
A	Austria	6830 Rankweil	Ländletechnik Schäfer GmbH	+43 - 5522 - 4 50 60
A	Austria	8020 Graz	Langbauer - Motoren GmbH.	+43 - 316 - 71 15 95
A	Austria	9170 Ferlach	Johann Koslitsch	+43 - 4227 - 59 33
AN	Angola	Luanda	Organizacoes JLM Lda.	+244 - 2 - 31 04 40
AUS	Australia	2164 Smithfield NSW	HATZ Australia Pty. Ltd.	+61 - 2 - 8788 7999
B	Belgium	4300 Wareme	Moes Diesel S.A	+32 - 19 - 33 92 92
BF	Burkina Faso	Ouagadougou 01	Impex Afrique	+226 - 50 43 37 37
BG	Bulgaria	1715 Sofia	ENERGIA-MARVAKOV	+359 - 29 62 14 95
BHT	Bhutan	Gongkhar Bumthang	Jigme Norbu Enterprise	+975 - 3 - 63 11 81 or 63 11 70
BR	Brazil	06413-690 Barueri - S.P.	Recomafe	+55 - 11 - 21 99 36 66
BRN	Bahrain	646 Nuwaidrat	Gulf Equipment & Technology (G.E.T.)	+973 - 170 00 08
BY	Belarus	223021 Minsk region	Fomar Ltd.	+375 - 17 - 507 68 20
CAM	Cameroon	DOUALA	EMEI DIESEL Sarl	+342 - 87 51
CDN	Canada	WI 53187-0258 Waukesha	HATZ Diesel of America, Inc.	+1 - 262 - 5 44 02 54
CH	Switzerland	8852 Altendorf	Motorenfabrik HATZ AG	+41 - 55 - 4 51 75 30
CI	Côte d' Ivoire	Abidjan 15	SEMAT	+225 - 21 21 84 84
CN	China	Xiamen	Motorenfabrik Hatz GmbH. & Co. KG.	+86 - 592 - 520 45 -28/-38/-78
CO	Columbia	Medellin	Eduardoño S.A.	+57 - 4 - 2 66 95 79
CR	Costa Rica	San Jose	Esco Costa Rica S.A.	+506 - 2 42 29 29
CY	Cyprus	3724 Limassol	L.NEMITSAS LTD	+357 - 25 - 56 92 25
CZ	Czech Republic	37001 Ceske Budejovice	David Servis spol. s.r.o.	+420 - 38 - 7 31 22 69
D	Germany	12057 Berlin	Fritz Bugel GmbH	+49 - (0)30 - 6 84 25 45
D	Germany	14774 Brandenburg / Plaue	Stolze Moto-Tech GmbH	+49 - (0)3381 - 4 04 70
D	Germany	15345 Altlandsberg	Alfons Hase	+49 - (0)33438 - 6 04 16
D	Germany	15831 Groß-Kienitz	Wilhelm Schmidt GmbH	+49 - (0)3 37 08 - 54 10
D	Germany	17235 Neustrelitz	Autek-Truck - Technik & Service GmbH	+49 - (0)3981 - 4 49 90
D	Germany	18055 Rostock	Mechanische Werkstatt	+49 - (0)381 - 69 08 20
D	Germany	19348 Düprow	Bernd Jüchert	+49 - (0)3876 - 78 89 31
D	Germany	21107 Hamburg (Wilhelmsburg)	SERVICEZENTRALE	+49 - (0)40 - 7 56 05 70
D	Germany	23556 Lübeck	Kindt-Motoren	+49 - (0)451 - 8 13 06 80
D	Germany	24145 Kiel - Wellsee	Wulf Johannsen KG GmbH & Co.	+49 - (0)431 - 71 20 25
D	Germany	26121 Oldenburg i.O.	Motoreninstandsetzung Oldenburg GmbH	+49 - (0)441 - 7 20 21/22
D	Germany	26789 Leer/Ostfriesland	Wilhelm Elbrecht	+49 - (0)491 - 9 71 11 57 / 9 71 11 58
D	Germany	2730 Ebersbach	Peter Hirche	+49 - (0)3586 - 36 23 79
D	Germany	28199 Bremen	Reinhold Linnenbrügger GmbH	+49 - (0)421 - 50 40 48 / 50 40 49
D	Germany	31275 Lehrte	GM-Motoreninstandsetzung	+49 - (0)5132 - 27 22
D	Germany	3130 Spremberg	Lischke Motortechnik	+49 - (0)3563 - 60 50 40
D	Germany	32756 Detmold	Wilhelm Plass	+49 - (0)5231 - 2 32 09
D	Germany	33611 Bielefeld	Faust & Noel e.K.	+49 - (0)521 - 6 18 83
D	Germany	36433 Moorgrund / OT Gumpelstadt	Autohaus Kallenbach	+49 - (0)3695 - 8 42 38
D	Germany	37081 Göttingen-Grone	Gerhard Wienstroth GmbH & Co. KG	+49 - (0)551 - 69 31 10
D	Germany	39124 Magdeburg	Motoreninstandsetzung GmbH	+49 - (0)391 - 28 92 11 0

HATZ service network



D	Germany	44143 Dortmund-Wambel	Dressendörfer GmbH & Co. KG	+49 - (0)231 - 59 30 89
D	Germany	4509 Wiedemar	SERVICEZENTRALE	+49 - (0)34207 - 7 44 0
D	Germany	47198 Duisburg	Wilhelm Nolden & Söhne	+49 - (0)2066 - 83 08 / 83 19
D	Germany	4749 Ostrau	Teichert GmbH	+49 - (0)34324 - 2 22 43 / 2 46 79
D	Germany	48282 Ermsdetten	Herbert Schwarte GmbH	+49 - (0)2572 - 50 02
D	Germany	48653 Coesfeld	Loick Motoren Technik GmbH. & Co. KG.	+49 - (0)2541 - 7 00 44
D	Germany	49716 Meppen/Ems	M. + E. Motoren- und Energietechnik	+49 - (0)5931 - 98 44-0
D	Germany	50859 Köln	Peter Müller GmbH	+49 - (0)2234 - 7 91 69
D	Germany	52477 Alsdorf - Mariadorf	B. Hamacher GmbH	+49 - (0)2404 - 9 85 60
D	Germany	52525 Heinsberg	Winkens GmbH	+49 - (0)2452 - 9 03 13-0
D	Germany	54292 Trier	motormobile	+49 - (0)651 - 43 68 60
D	Germany	56323 Waldesch	Seibert & Münch	+49 - (0)2628 - 29 01
D	Germany	57368 Lennestadt	Motoreninstandsetzung	+49 - (0)2725 - 2 47
D	Germany	59069 Hamm-Rhynern	Friedel Dicke GmbH	+49 - (0)2385 - 7 08 06-0
D	Germany	59609 Anröchte	Friedrich Dicke GmbH & Co.KG	+49 - (0)2947 - 979863
D	Germany	64293 Darmstadt	SERVICEZENTRALE	+49 (0)6151 - 39 7 49 0
D	Germany	67061 Ludwigshafen	ME Motoren- und Energietechnik	+49 - (0)621 - 58 71 17-0
D	Germany	67661 Kaiserslautern (Siegelbach)	Emrich GmbH	+49 - (0)6301 - 80 82, 80 83
D	Germany	69214 Eppelheim	Eberle Hald Handel u. Dienstleistungen	06221/7558 39 - 0
D	Germany	70188 Stuttgart	Eberle Hald Handel u. Dienstleistungen	0711/480 24 - 0
D	Germany	72555 Metzingen	Eberle Hald Handel u. Dienstleistungen	+49 - (0)7123 - 92 31 0
D	Germany	73492 Rainau-Goldshoefe	Eberle Hald Handel u. Dienstleistungen	07361/9718 02
D	Germany	76139 Karlsruhe	Ehlgötz	+49 - (0)721 - 6 23 54-0
D	Germany	76571 Gaggenau	SKS-Motoren GmbH	+49 - (0)7225 - 96 08 23
D	Germany	7806 Neustadt / Orla	Hoffmann & Sohn GmbH	+49 - (0)36481 - 29 60
D	Germany	78652 Deisslingen	Eberle Hald Handel u. Dienstleistungen	07425/3386 - 0
D	Germany	79211 Denzlingen	Karl Hoch GmbH	+49 - (0)7666 - 88 24-0
D	Germany	79331 Teningen - Nimbürg	Eberle Hald Handel u. Dienstleistungen	07663/9309 - 0
D	Germany	7957 Langenwetendorf	LAREMO GmbH	+49 - (0)3 66 25 / 5 52 07
D	Germany	81477 München	Stefan Lutzenberger	+49 - (0)89 - 78 20 39
D	Germany	83471 Berchtesgaden-Engedej	Friedrich Dicke GmbH & Co. KG	+49 - (0)8652 - 6 43 06
D	Germany	88074 Meckenbeuren	Eberle Hald Handel u. Dienstleistungen	07542/9410 - 0
D	Germany	90449 Nürnberg	Guth & Eberler GmbH	+49 - (0)911 - 6 88 79 53
D	Germany	94099 Ruhstorf	Motorenfabrik Hatz GmbH & Co. KG	+49 - (0)8531 - 31 90
D	Germany	94501 Aldersbach	Christian Sauer	+49 - (0)8543 - 91 60 81
D	Germany	9669 Frankenberg	V. Kluge GmbH	+49 - (0)37206 - 22 17
D	Germany	97904 Dorfprozelten	MSG Mainschiffahrts-	+49 - (0)9392 - 93 41-0
DK	Denmark	2630 Taastrup	Erenfred Pedersen A/S	+45 - 43 71 01 66
DK	Denmark	6000 Kolding	Erenfred Pedersen A/S	+45 - 76 33 60 60
DK	Denmark	9000 Aalborg	Erenfred Pedersen A/S	+45 - 98 13 77 22
DOM	Dominican Rep.	Santo Domingo	La Antillana Comercial, S.A.	+1 - 809 - 5 65 31 51
DZ	Algeria	Alger	Dieselec S.A.R.L.	+213 - 21 - 49 50 54 / 55 / 56
E	Spain	1013 Vitoria	Talleres Solaf, S.A.	+34 - 945 - 260781
E	Spain	15008 A Coruña	Talleres Hércules	+34 - 981 - 261650 / 252935
E	Spain	17469 Fortia (Girona)	Mauricio Xatart Tell	+34 - 972 - 534088
E	Spain	18080 Granada	Comercial Peña Torres	+34 - 958 - 816600



HATZ service network

E	Spain	18200 Maracena	Talleres Soriano	+34 - 958 - 410689
E	Spain	23009 Jaén	Comercial Peña Torres, S.A.	+34 - 953 - 28 05 77
E	Spain	25230 Mollerusa (Lleida)	Talleres Comaposada	+34 - 973 - 60 12 27
E	Spain	28320 Pinto (Madrid)	Austral Reparaciones y Servicios	+34 - 91 - 691 80 29
E	Spain	29004 Málaga	Comercial Peña Torres	+34 - 952 - 17 70 72
E	Spain	30500 Molina de Segura	Campos López	+34 - 968 - 386248
E	Spain	31192 Mutilva Alta	Maquinaria y Servicios ECA	+34 - 948 - 24 10 17
E	Spain	33211 Gijón	Maprinsa, S.A.	+34 - 985 - 167772
E	Spain	35008 El Sebadal	Fuendor	+34 - 928 - 46 53 06
E	Spain	38320 Taco	Fuendor (Repuestos)	+34 - 922 - 65 54 50
E	Spain	38350 Tacoronte	Fuendor (Taller)	+34 - 922 - 56 05 25
E	Spain	41500 Alcalá de Guadaíra	Blanco e Hijos	+34 - 955 - 63 01 89
E	Spain	43206 Reus (Tarragona)	Tractomecanic Maquinaria S.L.	+34 - 977 - 314923
E	Spain	46469 Beniparell (Valencia)	Talleres Rimi	+34 - 96 - 1 21 70 91
E	Spain	47193 La Cisterniga	Zafara	+34 - 983 - 476851 / 225620
E	Spain	47610 Zaratán	Talleres Sermacons S.L.	+34 - 983 - 342040
E	Spain	48014 Bilbao	Loter S.L.	+34 - 944 - 755853
E	Spain	50016 Zaragoza	Loma e Hijos, S.L.	+34 - 976 - 575177 / 570809
E	Spain	50171 La Puebla de Alfindén Zaragoza	Motores HATZ Espana S.L.U.	+34 - 976 - 10 81 28
E	Spain	7007 Palma de Mallorca	Comagriusa	+34 - 971 - 420137
E	Spain	7714 Mahón	Parot, S.A.	+34 - 971 - 360623
E	Spain	8038 Barcelona	Comercial Aim, S.L.	+34 - 93 - 3393250
EAK	Kenya	100 Nairobi	First Machineries Ltd.	+254 - 20 - 55 77 86
EC	Ecuador	Guayaquil	Compañía Comercial	+593 - 4 -256 05 02
ES	El Salvador	San Salvador	TEMSA	+503 - 22 76 22 23
ET	Egypt	11331 Cairo	Market Leaders	+20 - 2 - 4 53 07 63, 4 53 09 17
ETH	Ethiopia	Addis Abeba	Inter Supply	+251 - 1 - 50 77 77
EW	Estonia	11612 Tallinn	Estmotor Oü	+372 - 6 52 65 95
F	France	10350 Marigny Le Chatel	Garage Mathieu	+33 - 3 - 25 39 24 01
F	France	10350 Marigny Le Châtel	Garage Mathieu	+33 - 3 - 25 39 24 01
F	France	10350 Marigny-Le-Châtel	Garage Mathieu	+33 - 3 - 25 39 24 01
F	France	13852 Aix-en-Provence	I.M.F.	+33 - 4 - 42 90 30 65
F	France	14123 IFS	BOUVET S.A.S	+33 - 2 - 31 52 01 47
F	France	19100 Brive	Saint-Germain Rectif & Pradeau Moteurs	+33 - 5 - 55 86 91 91
F	France	19100 Brive	Saint-Germain-Rectif & Pradeau Moteurs	+33 - 5 - 55 86 91 91
F	France	21560 Arc-sur-Tille	Garage Remillet	+33 - 3 - 80 37 24 52
F	France	25410 Saint-Vit	DEPANNTP	+33 - 3 - 81 87 61 10
F	France	27002 Evreux Cédex	Demolin	+33 - 2 - 32 39 07 22
F	France	31300 Toulouse	MIDI-DIESEL ELECTRO ACCESSOIRES	+33 - 5 - 61 42 80 11
F	France	33704 Mérignac	Laporte	+33 - 5 - 56 34 20 26
F	France	33704 Mérignac	Laporte	+33 - 5 - 56 34 20 26
F	France	34671 Baillargues Cedex 1	L.M.S. (Languedoc Matériel Service)	+33 - 4 - 67 91 29 39
F	France	34671 Baillargues Cédex 1	L.M.S. (Languedoc Matériel Service)	+33 - 4 - 67 91 29 39
F	France	34671 Baillargues Cédex 1	L.M.S. (Languedoc Matériel Service)	+33 - 4 - 67 91 29 39
F	France	37170 Chambray-Les-Tours	Perron & Gay	+33 - 2 - 47 28 94 94
F	France	54710 Fléville	M.T.E. Services	+33 - 3 - 83 25 75 00

HATZ service network



F	France	56402 Auray Cedex	PENOUEST	+33 - 2 - 97 24 16 59
F	France	56402 Auray Cédex	PENOUEST	+33 - 2 - 97 24 16 59
F	France	59167 LALLAING	COMOTEQ	+33 - 3 - 27 99 35 23
F	France	67300 Schilligheim	ALSIA	+33 - 3 - 88 33 05 95
F	France	69680 Chassieu	HATZ France	+33 - 4 - 78 90 73 25
F	France	69680 Chassieu	HATZ-France	+33 - 4 - 78 90 73 25
F	France	69684 Chassieu Cedex	HATZ-France	+33 - 4 - 78 90 73 25
F	France	76807 Saint-Etienne du Rouvray Cedex	Morisse-Nayrat	+33 - 2 - 32 95 91 65
F	France	78610 Le Perray en Yvelines	Sudmat	+33 - 1 - 34 57 85 00
F	France	78703 Conflans-Ste-Honorine	Diesel Marine	+33 - 1 - 39 72 68 83
F	France	94290 Villeneuve le Roi	S.F.2.A	+33 - 1 - 49 61 30 90
FIN	Finland	1390 Vantaa	Finmotor Oy	+358 - 9 - 8 70 09 70
FJI	Fiji	Suva, Fiji Is.	Solar & Alternative	+679 - 3 39 80 06
G	Gabon	Libreville	MIAG	+241 - 76 00 31, 72 17 27
GB	Great Britain	BH21 7PE Dorset	Lewis & Lewis	+44 - 1202 - 87 61 71
GB	Great Britain	BL4 0LS Bolton	Seddons Plant	+44 - 1204 - 85 46 00
GB	Great Britain	CF24 5EL Cardiff	Aktion Automotive	+44 - 29 - 20 46 46 68
GB	Great Britain	CM9 5FA Essex	Taylor Construction Plant Ltd	+44 - 1621 - 85 07 77
GB	Great Britain	CV21 1PB Warks	BrownPower Eng Ltd	+44 - 1788 - 57 75 75
GB	Great Britain	FK16 6AU Perthshire	Young Plant & Equipment	+44 - 1786 - 84 15 98
GB	Great Britain	GL17 0IA Gloucestershire	Titan Industrial Ltd	+44 - 1452 - 83 18 21
GB	Great Britain	KT19 8JD Surrey	Meetens Industrial Engines	+44 - 845 - 6 34 02 97
GB	Great Britain	LE10 3BP Hinckley, Leics.	HATZ Great Britain Ltd.	+44 - 1455 - 62 21 01
GB	Great Britain	LN1 2LR Lincoln	CG Plant Sales	+44 - 1522 - 70 40 14
GB	Great Britain	LS12 6EP Leeds	W.G. Search Ltd	+44 - 1132 - 79 79 90
GB	Great Britain	LS12 JAJ Leeds	Chippindale Plant Ltd	+44 - 113 - 2 63 23 44
GB	Great Britain	NE4 7AX Newcastle	John Nixon Ltd.	+44 - 191 - 2 26 06 66
GB	Great Britain	NN11 5QJ Northants	Bryco Group Ltd.	+44 - 1327 - 87 61 66
GB	Great Britain	NR31 ONL Great Yarmouth	Prior Diesel Ltd	+44 - 1493 - 44 13 83
GB	Great Britain	PL12 6LX Cornwall	AB Services Ltd.	+44 - 1752 - 84 88 20
GB	Great Britain	SN8 2RN Wiltshire	T.H. White	+44 - 1672 - 51 23 28
GB	Great Britain	SO53 3ZL Eastleigh	Selwood Ltd.	+44 - 23 - 80 26 63 11
GB	Great Britain	ST4 3NX Stoke-on-Trent	Seddons Plant	+44 - 1782 - 59 34 44
GB	Great Britain	TS18 2PF Stockton	John Nixon Ltd.	+44 - 1642 - 67 26 94
GCA	Guatemala	Guatemala, Ciudad	Técnico Mercantil S.A.	+502 - 3 31 41 93, 3 34 34 84,
GH	Ghana	Accra - North	Agria Machinery	+233 - 302 - 22 21 69
GN	Guinea	Conakry	Injelec s.a.r.l.	+224 - 11 22 83 84
GR	Greece	11855 Athens	DIM	+30 - 210 - 3 41 73 63
GUA	Guadeloupe	97176 Abymes Cedex	Assistance 97 Guadeloupe	+590 - 590 47 09 90
GUY	Guyana	97351 Matoury	Assistance 97	+594 - 594 252 - 913
H	Hungary	1165 Budapest	Benaco	+36 - 1 - 4 07 37 34
HK	Hong Kong	. Hong Kong	HD Engineering Ltd.	+852 - 26 75 47 89
HN	Honduras	Tegucigalpa, D.C.	Corporación Comercial, S.A. de C.V.	+504 - 237 - 67 90
HR	Croatia	10000 Zagreb Hrvatska	Diesel Motori d.o.o.	+385 - 1 - 3 46 35 18, 3 46 26 69
I	Italy	10138 Torino	Centro Ricambio	+39 - 011 - 4 55 11 81/ 4 55 12 11
I	Italy	12030 Faule (Cn)	Multidiesel di Barge Ilario	+39 - 338 - 7 19 94 09



HATZ service network

I	Italy	133 Roma	Eros Antonelli S.N.C.	+39 - 06 - 72 65 02 60
I	Italy	14056 Boglietto di Costigliole d'Asti AT	Barbero Andrea	+39 - 0141 - 96 82 93
I	Italy	16100 Genova	Bruzzone Enzo	+39 - 010 - 3 73 93 96
I	Italy	20068 Peschiera Borromeo (MI)	C.S.D. Centro Servizi Diesel S.R.L.	+39 - 02 - 55 303 000
I	Italy	21040 Origgio (VA)	C.M.R. s.n.c. di Bianchi Roberto & C.	+39 - 02 - 96 73 20 62
I	Italy	22046 Erba CO	Miotto Luciano	+39 - 031 - 64 16 73
I	Italy	24050 Orio al Serio BG	Marconi & Caldara	+39 - 035 - 31 25 76 / 077 04 35
I	Italy	25021 Bagnolo Mella (Bs)	Officina Meccanica	+39 - 030 - 68 21 441
I	Italy	29017 Fiorenzuola d'Arda PC	Arduini Luigi di Arduini Armando	+39 - 0523 - 98 26 39
I	Italy	31030 Carbonera (TV)	Centro Ricambi	+39 - 0422 - 69 55 11
I	Italy	33010 Feletto Umberto Tavagnacco Ud.	Ezio Fiorin Eredi di Alberto Fiorin & C.	+39 - 0432 - 57 30 76
I	Italy	33078 San Vito al Tagliamento (PN)	Officina Venaruzzo Antonio	+39 - 0434 - 87 63 77
I	Italy	34015 Muggia TS	Centro Ricambio	+39 - 040 - 23 17 15
I	Italy	35030 Vo	Giuseppe Marcolongo	+39 - 049 - 9 94 06 76
I	Italy	36060 Romano d'ezzelino (VI)	Parolin Enzo	+39 - 0424 - 3 09 75
I	Italy	38010 S. Michele all'Adige TN	Campese S.N.C.	+39 - 0461 - 65 01 69
I	Italy	39100 Bolzano	Officina D'Ambrosio	+39 - 0471 - 20 42 00
I	Italy	40060 Trebbo Di Reno (BO)	Venturoli Lauro	+39 - 051 - 70 02 41
I	Italy	4014 Borgo Vodice (LT)	Dorati Luciano	+39 - 0773 - 85 01 09
I	Italy	41100 Modena (MO)	Centro Ricambi	+39 - 059 - 33 41 10
I	Italy	41122 Modena	HATZ Italia S.R.L.	+39 - 059 - 25 41 29
I	Italy	43100 Parma	Arduini Franco e Figlio S.N.C.	+39 - 0521 - 48 75 66
I	Italy	44043 Marzabotto BO	Lolli F.C.	+39 - 051 - 93 24 41
I	Italy	47023 Cesena (FO)	Domeniconi Egisto Romano & C. S.N.C.	+39 - 0547 - 32 55 13
I	Italy	50053 Empoli (FI)	O.R.M.A. di Niccolai Dino e	+39 - 0571 - 8 03 04
I	Italy	50142 Firenze (FI)	Centro Ricambi	+39 - 055 - 7 32 74 43
I	Italy	5100 Terni	Lamperini Services	+39 - 0744 - 30 62 10
I	Italy	60035 Jesi AN	Cercaci Officina Meccanica	+39 - 0731 - 20 50 46
I	Italy	6061 Castiglione del Lago	Della Giovampaola Danilo	+39 - 075 - 96 52 433
I	Italy	66020 Sambuceto (CH)	CO. GAL. CO. S.R.L.	+39 - 085 - 44 600 55
I	Italy	70123 Bari	Morettauto S.R.L.	+39 - 080 - 50 585 60
I	Italy	70123 Bari	Rettifiche de Palma	+39 - 080 - 5 34 16 38
I	Italy	7026 Olbia SS	Usai Pietrino & C. S.N.C.	+39 - 0789 + 6 94 19
I	Italy	71016 San Severo FG	Ianzano F. LLI Raffaele e Luigi	+39 - 0882 - 33 14 18
I	Italy	73020 Martignano (LE)	Coriano Tomasso Officina Meccanica	+39 - 0832 - 80 10 08
I	Italy	74015 Martina Franca (TA)	Fratelli Cannella SNC	+39 - 080 - 48 552 59
I	Italy	80026 Casoria (NA)	CO. MAC. S.R.L.	+39 - 081 - 7 59 42 76, 7 59 08 00
I	Italy	8100 Nuoro	Lostia Sebastiano	+39 - 0784 - 20 15 26
I	Italy	84069 Roccadaspide (SA)	Sforza Marcello	+39 - 0828 - 94 18 34
I	Italy	85043 Latronico PZ	Falabella Egidio	+39 - 0973 - 85 81 41
I	Italy	87036 Rende CS	Viteritti Alfonso	+39 - 0984 - 40 39 36
I	Italy	88074 Crotona	R.A.I.M. S.A.S.	+39 - 0962 - 2 28 69
I	Italy	9034 Elmas CA	De Murtas Antonio & C. S.A.S.	+39 - 070 - 21 61 06
I	Italy	9170 Oristano OR	Pistis Giovanni	+39 - 0783 - 35 70 22
I	Italy	95131 Catania	Coco Gaetano di C. Mario e	+39 - 095 - 53 96 50
I	Italy	97100 Ragusa (RG)	Ricca S.R.L.	+39 - 0932 - 66 74 00

HATZ service network



I	Italy	98071 Capo d'Orlando ME	Motagrind S.D.F. di Mangano & Scarvaci	+39 - 0941 - 90 19 59
IL	Israel	81100 Yavne, Israel	Shatal Engineering Ltd.	+972 - 8 - 9 32 02 20
IND	India	110008 New Delhi	SKL (India) Pvt. Ltd.	+91 - 11 - 25896075
IND	India	400072 Mumbai	SKL (India) Pvt. Ltd.	+91 - 22 - 28 47 66 49
IR	Iran	Tehran	Mr. B. Amyari	+98 - 9123152982
IRL	Ireland	BT36 8BX Mullusk	T.B.F. Thompson	+44 - 2890 - 84 83 71
IRL	Ireland	BT51 5JZ Coleraine	T.B.F. Thompson	+44 - 28 - 29 55 83 53
IRL	Ireland	Dublin	TBF Thompson	+353 - 1 - 4 01 93 00
IS	Iceland	110 Reykjavik	Tækjasalan ehf.	+35 - 4 - 5 67 25 20
J	Japan	364-8511 Saitama	Fuji Heavy Industries Ltd.	+81 - 48 - 5 93 77 82
JOR	Jordan	11118 Amman	Al Ghanem	+962 - 6 - 4 39 51 55
KAZ	Kazakhstan	60009 Atyrau	InterKazService	+7 7122 20 23 05
KSA	Saudi Arabia	21462 Jeddah	Electrical Work & Maintenance	+966 - 2 - 6 91 66 55
KWT	Kuwait	Kuwait	Sabah International	+965 - 4 81 82 43
LT	Lithuania	52367 Kaunas	PLLC MASTERMANN	+370 - 37 - 45 31 55
LV	Latvia	1035 Riga	KONO Ltd.	+371 - 67 - 14 94 25
MA	Morocco	MA-Casablanca	SONACOM	+212 - 5 - 22 24 97 00
MAL	Malaysia	47100 Puchong	Autorex Engineering & Trading	+603 - 80 61 06 68
MAT	Martinique	97232 Le Lamentin	Assistance 97	+596 - 5 96 50 30 00
MAW	Malawi	3 Blantyre	Engineering and Foundry	+2651 - 671241/672028
MEX	Mexico	C.P. 66477 Mexico	MAQRO S.A. de C.V.	+52 - 81 - 81 31 20 00
MOC	Mozambique	Maputo	ABC Trading Lda.	+258 - 21 - 30 92 79
MV	Maldives	Male	MA Services Pvt. Ltd.	+960 - 3 31 09 35
N	Norway	192 Oslo	HydEl Consult A/S	+47 - 22 - 57 21 17
N	Norway	4870 Fevik	Industrimotor AS	+47 - 37 - 09 16 00
NAM	Namibia	Windhoek	ConServ Engineering Services C.C.	+264 - 61 - 23 63 36
NL	Netherlands	3311 JC Dordrecht	Machinefabriek Dolderman BV	+31 - 78 - 6 13 82 77
NL	Netherlands	4104 AE Culemborg	HATZ Nederland BV	+31 - 345 - 47 00 40
NL	Netherlands	8013 NE Zwolle	Janal Engineering BV	+31 - 38 - 4 60 22 00
NL	Netherlands	9301 ZV Roden	Ausma Motorenrevisie B.V.	+31 - 50 - 5 01 60 28
NZ	New Zealand	Auckland, New Zealand	Youngman, Richardson and Co. Ltd.	+64 - 9 - 4 43 24 36
OM	Oman	Al-Mawaleh South, Al-Seeb	INMA CO. OMAN LLC	00968 24552455
P	Portugal	2625 Lisboa	Pinto & Cruz, Limitada	+351 21 7 11 21 00
P	Portugal	4103-801 Porto Codex	Pinto & Cruz, Limitada	+351 - 22 - 6 15 05 58
PA	Panama	Panamá 5	Dimar, S.A.	+507 - 2 29 14 44
PE	Peru	Lima - ATE	OR MAQUINARIAS S.A.C.	0051 1 719 0359
PL	Poland	03-046 Warszawa	Full Sp. Z o.o.	+48 - 22 - 8 19 40 40
PL	Poland	30-732 Krakow	Wakbud Sp. Z o.o.	+48 - 12 - 6 53 25 37
PL	Poland	41-803 Zabrze	Wobis	+48 - 32 - 2 75 32 26
PL	Poland	55-010 Zerniki Wroclawskieawskie	Maszyny Budowlane "JAS"	+48 - 89 - 5 34 59 74
PL	Poland	84-122 Zelistrzewo	E.M.A. Hochschulz S.C.	+48 - 58 - 6 73 60 80
PL	Poland	85-758 Bydgoszcz	Technet S.C.J.	+48 - 52 - 3 70 70 90
PL	Poland	95-100 Zgierz	Broker - Serwis	+48 - 42 - 7 16 65 04
PNG	Papua New G.	2164 Smithfield NSW	please contact:	+61 - 2 - 8788 7999
Q	Qatar	Doha	INMA Company - Qatar L.L.C.	+974 - 4 - 43 00 88
RA	Argentina	S 2252 BMR Galvez (Santa Fé)	Bounous Hnos S.A.	+54 - 3404 - 48 16 10



HATZ service network

RB	Botswana	Gabarone	Orbit Pumps (Botswana) (Pty.) Ltd.	+267 - 397 49 26
RC	Taiwan	768441 Singapore	EquipSource Pte Ltd	+65 - 67 59 22 96
RCB	Congo	3689 Kinshasa-Gombe	Bureau Technique BIA sprl	+243 - 81 - 1 60 23 95
RCH	Chile	Santiago	Tecnica de Maquinarias Ltda.	+56 - 2 - 7 82 92 75
REU	Réunion	97461 St. Denis Cedex	Société FOUCQUE S.A.	+262 - 48 87 87
RH	Haiti	HT-8110 Haiti	Les Ateliers - Ecole de Camp-Perrin	+509 - 286 00 52 / 1280
RI	Indonesia	768441 Singapore	Please contact our agent in Singapore	+65 - 67 59 22 96
RIM	Mauritania	Nouakchott	SODEQ S.A.	+222 - 5 25 47 30
RL	Lebanon	1102-2070 Beirut	Najib Baki & Sons	+961 - 1 - 36 52 62
RM	Madagascar	Tananarive	Société Ameca	+261 - 20 - 2 22 30 16
RMM	Mali	Bamako	Dupé S.A.	+223 - 2 21 52 30
RO	Romania	12051 Bucharest	Fland Gruppe srl.	+40 - 21 - 3 36 11 30/ -50
ROK	Korea	150-972 Seoul-Youngdeungpo-Gu	U-YOUNG INDUSTRIAL CO.LTD.	+82-2-3439-1611
ROU	Uruguay	12900 Montevideo	Bromberg y Cia. S.A.	+598 - 2 - 3 55 77 70
RP	Philippines	Quezon City	M & W Distributing Co. Inc.	+63 - 2 - 3 71 19 36
RS	Serbia	11120 Beograd	IWE d.o.o.	+381 - 11 2 76 65 65
RT	Togo	- Lomé	Togomat S.A.	+228 - 27 23 95
RU	Burundi	Bujumbura	Metalubia	+257 - 22 - 23 30
RUS	Russia	129336 Moscow	<-Stend> ltd	+7 - 495 - 4 74 60 31
RUS	Russia	193315 Sankt-Petersburg	MKSМ-Servis Spb	+7 - 812 - 309 03 80
RUS	Russia	346405 Nowotscherkassk	AUTOENERGIESYSTEME	+7 - 8635 - 23 42 91
RUS	Russia	390028 Ryazan	PromDizel Limited Corp.	+7 - 4912 - 33 24 45
RUS	Russia	628404 Surgut	MKSМ - Servis Surgut	+7 - 3462 - 67 33 06
RUS	Russia	640007 Kurgan	Ural-Hatz-Diesel	+7 - 3522 - 54 54 50
S	Sweden	13650 Haninge	Swedmotor AB	+46 - 8 - 50 01 21 40
S	Sweden	17239 Sundbyberg	Dixner & Co AB	+46 - 8 - 29 12 03
S	Sweden	21376 Malmö	Elektro-Diesel Autoservice AB	+46 - 40 - 21 03 65
S	Sweden	23236 Arlöv	MT Service AB	+46 - 40 - 43 73 65
S	Sweden	34013 Hamneda	Sjödahls Repservice	+46 - 372 - 5 40 76
S	Sweden	37182 Karlskrona	S. Jeppson AB	+46 - 455 - 38 80 00
S	Sweden	58112 Linköping	Branzells elektro-diesel ab	+46 - 13 - 31 09 00
S	Sweden	59892 Vimmerby	Mek & Maskin	+46 - 496 - 4 02 40
S	Sweden	63346 Eskilstuna	Larssons Motor AB	+46 - 16 - 13 60 04
S	Sweden	65110 Karlstad	Branzells elektro-diesel ab	+46 - 54 - 85 29 00
S	Sweden	65111 Karlstad	Värm-dal Maskin AB	+46 - 54 - 13 77 00
S	Sweden	67141 Arvika	Arvika Bil El	+46 - 570 - 71 15 90
S	Sweden	67222 Årjäng	Myrvolds Maskin	+46 - 573 - 1 30 52
S	Sweden	70140 Örebro	Branzells elektro-diesel ab	+46 - 19 - 27 40 00
S	Sweden	72137 Västerås	Branzells elektro-diesel ab	+46 - 21 - 81 03 10
S	Sweden	83148 Östersund	Siljeströms Motorrenovering AB	+46 - 63 - 10 60 70
S	Sweden	85751 Sundsvall	LHS Maskiner	+46 - 60 - 57 72 20
S	Sweden	89495 Moliden	Flärke Kojsservice AB	+46 - 660 - 9 11 42
S	Sweden	90586 Umeå	Larsson Maskin AB	+46 - 90 - 14 73 30
S	Sweden	93621 Boliden	BPA Industriteknik AB	+46 - 910 - 77 42 15
S	Sweden	98138 Kiruna	Truck & Maskin AB Kiruna	+46 - 980 - 1 50 20
S	Sweden	98222 Gällivare	Holmgrens Truck & Motor	+46 - 970 - 1 45 40

HATZ service network



SGP	Singapore	768441 Singapore	EquipSource Pte Ltd	+65 - 67 59 22 96
SK	Slavakia	91501 Nové Mesto n/V.	OTS Bratislava, spol. s.r.o.	+421 - 032 - 77 15 49 7
SLO	Slovenia	2000 Maribor	VZDRZEVANJE NEJC, D.O.O.	+386 - 2 - 420 11 98
SME	Suriname	Paramaribo	Meindertsma Surinam N.V.	+597 - 40 46 94, 40 33 88
SN	Senegal	Dakar	MATFORCE	+221 - 33 - 839 95 00
SYR	Syria	- Damascus	Electromechanical Equipment	+963 - 11 - 2 21 39 55 / 2 21 56 78
TAH	Tahiti	98701 Arue	Ets. Dieumegard	+689 - 6 89 42 32 38
THA	Thailand	10120 Bangkok	General Diesel (Thailand) Co. Ltd.	+662 - 2 94 08 75 - 6, 2 84 08 28
TN	Tunesia	1001 Tunis	S.I.A Ben Djemaa & Cie	+216 - 71 24 25 66
TN	Tunesia	3000 Sfax	S.I.A Ben Djemaa & Cie	+216 - 74 40 84 09
TR	Turkey	34852 Maltepe Istanbul Turkey	Efes Makina Sanayi ve dis Ticaret Ltd. STI	+90 - 216 - 3 67 35 75
TT	Trinidad and Tob.	San Fernando	Electrodiesel & Co. Ltd.	+1 - 868 - 652 - 37 10
UA	Ukraine	1034 Kiev	ERA - Engineering Remake Aggregate	+380 - 44 - 5 99 16 44
UAE	United Arab. Em.	Dubai	INMA	+971 - 4 - 2 85 72 72
USA	United States	WI 53187-0258 Waukesha	HATZ Diesel of America, Inc.	+1 - 262-544-0254
UZB	Uzbekistan	Tashkent	Kartash Service	+998 - 7 11 33 57 59
VN	Vietnam	768441 Singapore	Please contact our agent in Singapore	+65 - 67 59 22 96
WAL	Sierra Leone	Freetown	Joe Tech	+232 - 77 - 23 21 72
WAN	Nigeria	- Lagos	A1 Multi Services Limited	+234 - 1 - 7 21 67 21
YAR	Rep. of Yemen	Sana'a	Al Mahtadi & Abo-Miskah Co. Ltd.	+967 - 1 - 22 47 66, 22 25 29
YV	Venezuela	Caracas	Maquinarias Larraq, C.A.	+58- 212 - 9 44 16 31 / 9 44 56 29
ZA	South Africa	3630 Westville	Hatz Diesel (S.A.) Pty. Ltd. Durban	+27 - 31 - 7 00 48 38
ZA	South Africa	Bloemfontein	CPR Maintenance CC	+27 - (0)51 - 4 47 96 18
ZA	South Africa	Capetown	Compaction & Industrial Equipment C.C.	+27 - (0)21 - 9 49 77 67
ZA	South Africa	Edenvale	Hatz Diesel (S.A.) Pty. Ltd.	+27 - 11 - 5 74 09 00
ZA	South Africa	Port Elizabeth	S & K Diesels cc	+27 - 41 - 5 83 37 80
ZW	Zimbabwe	Harare	R & S Diesel Pro Services (Pvt.) Ltd.	+26 - 34 33 15 59

Serien-Nr.-Änderungen
Serial-code modification list
Modification des Nos de serien
Modificación de los Nos de serie
Modifica dei codici

IMT-No.

1 B 20 V.10	1 B 20 V.11	98.580
1 B 20 V.11	1 B 20 V.12	00.590
1 B 20 V.12	1 B 20 V.13	00.595
1 B 20 V.13	1 B 20 V.14	00.598
1 B 20 V.14	1 B 20 V.15	01.613
1 B 20 V.15	1 B 20 V.16	02.617
1 B 20 V.16	1 B 20 V.17	02.619
1 B 20 V.17	1 B 20 V.18	03.629
1 B 20 V.18	1 B 20 V.19	05.649
1 B 20 V.19	1 B 20 V.20	06.662
1 B 20 V.20	1 B 20 V.21	09.679
1 B 20 V.21	1 B 20 V.22	10.698

1 B 30 V.10	1 B 30 V.11	00.598
1 B 30 V.11	1 B 30 V.12	00.607
1 B 30 V.12	1 B 30 V.13	01.613
1 B 30 V.13	1 B 30 V.14	02.617
1 B 30 V.14	1 B 30 V.15	05.649
1 B 30 V.15	1 B 30 V.16	06.660
1 B 30 V.16	1 B 30 V.17	09.683
1 B 30 V.17	1 B 30 V.18	10.699