

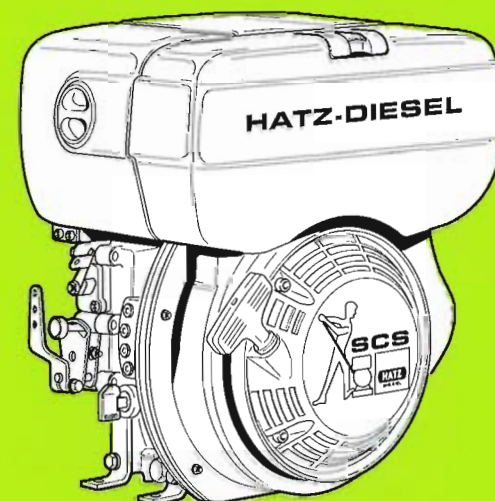

**MOTORENFABRIK HATZ • D-94099 RUHSTORF • Germany**  
Tel.: 0 85 31 / 319-0 • Telefax: 0 85 31 / 31 94 18  
eMail: marketing@hatz-diesel.de • <http://www.hatz-diesel.de>

# Original-Ersatzteile

Original-spare parts  
Pièces de rechange d'origine  
Repuestos originales  
Pezzi di ricambio originali



**1B20**  
**1B30**

434 800 09 - 11.01-5  
Printed in Germany

# Bestellung für HATZ-Original-Ersatzteile

Order for HATZ Original spare parts

Commande de pièces d'origine HATZ

Pedido de repuestos originales HATZ

Ordine parti di ricambio originali HATZ

Besteller / Customer / Client / Cliente / Cliente

TYP	KENNZ.
MOTOR/FABRIK NO.	
MIN <sup>-1</sup>	



Ersatzteilliste Nr./ Spare parts list no./ Liste des pièces de rechange no./ Lista de repuestos No./ Lista ricambi n.

1 B 20 . 26

1 B 30 . 22

Stück / Qty / Q.tà	HATZ Ident No.	Stück / Qty / Q.tà	HATZ Ident No.

Versandart / Mode of dispatch / Mode d'expédition / Despacho deseado / Modo di spedizione

Post / Surface / Poste / Correo / Posta  Luftfracht / airfreight / frêt aérien / flete aereo / Via aerea   
Express / express / exprès / expreso / Espresso  .....

Versandadresse / Consignee / Adresse destination / Dirección / Indirizzo di destinazione

Bestellung an: Order at: Commande à: Pedido a:

- die nächste HATZ-Servicestelle (siehe Servicestellenverzeichnis)

- your nearest HATZ service station (see service-list)

- votre station-service HATZ la plus proche (voir liste "Service")

- al servicio HATZ más cercano (ver cuaderno de Servicio)

- al più vicino centro di servizio HATZ (vedi lista centri autorizzati)

**MOTORENFABRIK HATZ**

**D-94099 RUHSTORF**

Tel: 0 85 31 / 319 - 0

Fax: 0 85 31 / 31 94 21



<b>Inhaltsverzeichnis</b>		<b>Index</b>	<b>Tafel-Nr. Table No.</b>
<b>M ..</b>	<b>Grundmotor</b>	<b>Basic engine</b>	
00	Ersatzteilsätze	Spare parts kits	01
34	Zubehör	accessories	02
01	Kurbelgehäuse	Crankcase	03
02	Kurbelwelle	Crankshaft	04
04	Nockenwelle	Camshaft	05
05, 06	Kolben, Pleuel, Zylinder	Piston, conrod, cylinder	06
07	Zylinderkopf	Cylinder head	07
10, 32	Ölpumpe, Regler, Drehzahlverstellung	Oil pump, governor, speed control	08
11	Steuerdeckel	Timing cover	09
13, 17	Gebälse, Schwungrad	Blower, flywheel	10
14	Einspritzausrüstung	Injection equipment	11
15	Reversierstarter	Recoil starter	12
26	Luftführung 1 B 20	Air ducting 1 B 20	13
26	Luftführung 1 B 30	Air ducting 1 B 30	14
31	Kurbelgehäuseentlüftung	Crankcase breathing system	15
<b>A ..</b>	<b>Zusatzausrüstung</b>	<b>Equipements</b>	
01	Kraftstoffbehälter	Fuel tank	16
01	Kraftstoffbehälter mit externem Filter und Wasserabscheider	Fuel tank with external filter and water separator	17
02	Luftfilter	Air filter	18
03	Abgasdämpfer 1 B 20	Exhaust silencer 1 B 20	19
03	Abgasdämpfer 1 B 30	Exhaust silencer 1 B 30	20
05	Starter, Generator	Starter, alternator	21
05, 10	Armaturen, Leitungen	Electric equipment, wirings	22
09	Drehzahlverstellung	Speed control	23
09	Drehzahlverstellung-Bowdenzug	Speed control-bowden cable	24
18	Anbauteile Hydraulikpumpe	Mount. parts hydr. pump	25
90	Motorausrüstung EPA	Spec. equipment EPA	26

**Sommaire**

**Indice**

<b>M ..</b>	<b>Moteur de base</b>	<b>Motor de base</b>	
00	Jeu de pièces de rechange	Juegos de recambios	01
34	Accessoires	Accesorios	02
01	Carter moteur	Caja cigueñal	03
02	Vilebrequin	Cigueñal	04
04	Arbre à cames	Arbol de levas	05
05, 06	Piston, bielle, cylindre	Embolo, biela, cilindro	06
07	Culasse	Culata	07
10, 32	Pompe a huile, regulateur regime, réglage regime	Bomba de aceite, regulador, ajuste de revoluciones	08
11	Couvercle distribution	Tapa de mando	09
13, 17	Soufflerie, volant	Ventilador, volante	10
14	Equipment d'injection	Equipo de inyección	11
15	Demarreur reversible	Arrancador reversible	12
26	Carter ventilation 1 B 20	Conducción de aire 1 B 20	13
26	Carter ventilation 1 B 30	Conducción de aire 1 B 30	14
31	Reniffard	Purgador	15
<b>A ..</b>	<b>Accessoires</b>	<b>Equipos</b>	
01	Reservoir à carburant	Depósito combustible	16
01	Reservoir avec filtre externe et décanteur d'eau	Deposito con filtro externo y separador de agua	17
02	Filtre à air	Filtro de aire	18
03	Silencieux 1 B 20	Silenciador 1 B 20	19
03	Silencieux 1 B 30	Silenciador 1 B 30	20
05	Demarreur, alternateur	Arrancador, alternator	21
05, 10	Equipement électrique, cable	Equipo eléctrico, cables	22
09	Reglage régime	Ajuste de velocidad	23
09	Reglage régime bowden	Ajuste de velocidad bowden	24
18	Pièces mont.-pompe hydr.	Piezas mont. bomba hidr.	25
90	Equip. spec. EPA	Equipo espec. EPA	26

Indice		Tavola N.
<b>M ..</b>	<b>Motore di base</b>	
00	Serie guarnizioni	01
34	Kit accessori	02
01	Basamento motore	03
02	Albero a gomito	04
04	Albero a camme	05
05, 06	Pistone, biella, cilindro	06
07	Testa	07
10, 32	Pompa olio, regolatore di giri, Comando acceleratore	08
11	Coperchio distribuzione	09
13, 17	Ventilatore, volano	10
14	Equipaggiamento di iniezione	11
15	Avviamento a strappo	12
26	Carter ventilatore 1 B 20	13
26	Carter ventilatore 1 B 30	14
31	Sfiato basamento	15
<b>A ..</b>	<b>Accessori</b>	
01	Serbatoio	16
01	Serbatoio con filtro esterno e separ. d'aqua	17
02	Filtro aria	18
03	Scarico 1 B 20	19
03	Scarico 1 B 30	20
05	Motorino avviamento, alternatore	21
05, 10	Equipaggiam. elettrico, cablaggio	22
09	Comando acceleratore	23
09	Comando acceleratore bowden	24
18	Particorari per montaggio pompa idraulica	25
90	Kit trasformazione EPA	26

**M 00** Ersatzteilsatz  
Spare part kits  
Jeux de pièces de rechange  
Juegos de piezas de recambios  
Serie guarnizioni

Tafel Nr.  
Tabl. No.  
Tavola N.

**01**

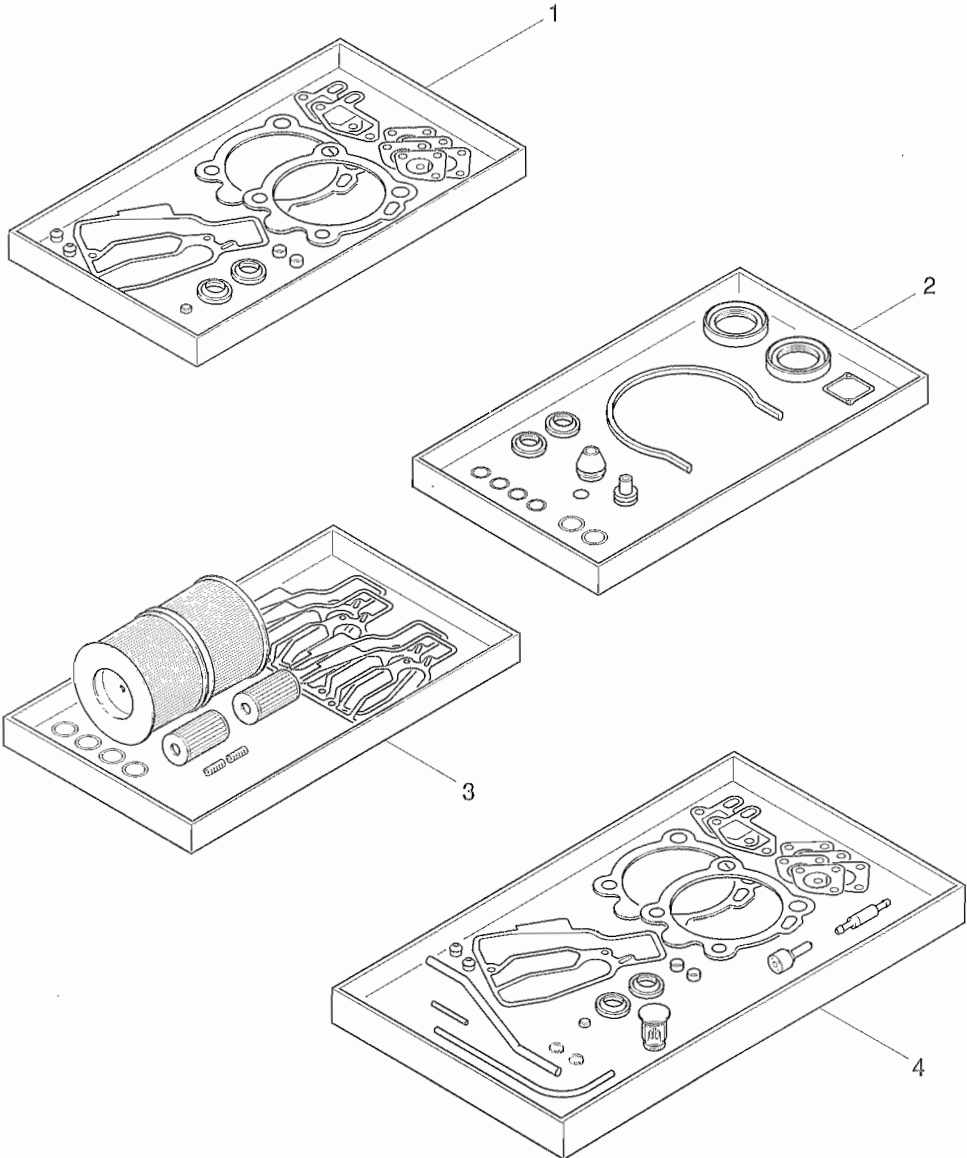

Fig.-No.	HATZ Ident-No.	Stück Qty.		P / W d / D	Bemerkungen Notes	
		1B20	1B30			
W:	Im Wartungssatz enthalten. Incl. in maintenance kit. Contenu dans le jeu d'entretien. Includido en el juego de mantenimiento. Contenuto nella serie manutenzione.				P:	Im Pannensatz enthalten. Incl. in emergency kit. Contenu dans le jeu secur. Includido en el juego para averias. Contenuto nella serie di prima necessità.
d:	Im Dichtungssatz für Zyl.-K. enth. Incl. in gasket set for cyl. head. Contenu dans le jeu de joint pour culasse. Includido en el juego de juntas p. culata. Contenuto nella serie guarnizioni per testa.				D:	Im Dichtungssatz Kurbelgeh. Incl. in gasket set crankcase. Contenu dans le jeu de joints carter moteur. Includido en el juego de juntas caja cigueñal. Contenuto nella serie guarnizioni basamento.
					1:	Anzahl pro Satz - Qty. per kit. Quantite par jeu. Cantidad por juego. Quantità per serie.
1	015 541 00	1	-	P1	Dichtungssatz für Zylinderkopf.	
1	015 822 00	-	1	P1	Gasket set for cyl. head. Jeu de joint pour culasse. Juego de juntas para culata. Serie guarnizioni per testa.	
2	015 542 01	1	-		Dichtungssatz für Kurbelgehäuse.	
2	015 823 02	-	1		Gasket set for crankcase. Jeu de joints p. carter moteur. Juego de juntas para caja cigueñal. Serie guarnizioni basamento.	
3	015 543 10	1	-		Wartungssatz für 1000 h.	
3	015 824 10	-	1		1000 hours maintenance kit. Kit d'entretien 1000 heures - Juego de piezas para servicio 1000 horas. Kit di manutenzione a 1000 ore.	
4	015 544 10	1	-		Pannensatz - Emergency kit.	
4	015 825 00	-	1		Kit de secours - Juego para averias Kit di prima necessità.	



M 34

Zubehör  
Accessoires  
Accessoires  
Accessoires  
Kit accessori

Tafel Nr.  
Tabl. No.  
Tavola N.

02

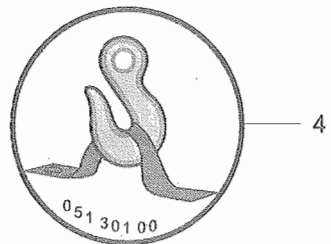
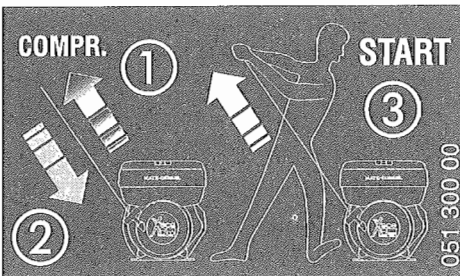
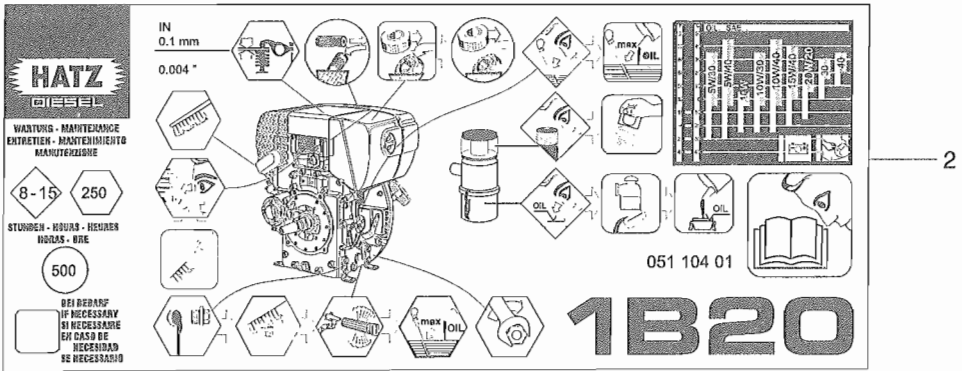
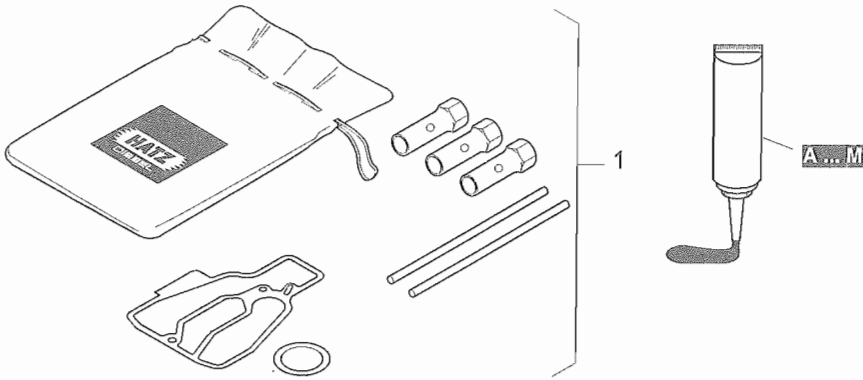

Fig.-No.	HATZ Ident-No.	Stück Qty.	P / W d / D	Bemerkungen Notes
		1B20	1B30	
1	013 310 01	1	-	Zubehörpaket - Accessoires kit
1	015 787 00	-	1	Sort. accessoires Juego de accesorios Serie accessori
2	051 104 01	1	-	160 x 67 mm
2	051 201 00	-	1	
3	051 300 00	1	1	
4	051 301 00	1	1	

Dicht- und Klebstoffe  
Sealing- and bonding adhesives  
Étanchéifiant et Colle

Materias para empaquetar y pegar  
Adesivi e collanti

A = 502 230 01	Loctite Activator N	500 ml	} siehe Hinweis auf den einzelnen Bildtafeln
B = 502 231 00	Loctite 573	50 ml	
C = 502 232 00	Loctite 601	50 ml	
D = 502 233 00	Loctite 221	50 ml	
E = 502 234 00	Loctite 648	10 ml	
F = 502 238 00	Technicoll 8058	0,75 kg	
+ 502 239 00	Technicoll 8367	0,75 kg	
G = 502 565 01	Loctite IS 407	20 g	
H = 502 825 01	Silicon	30 ml	
J = 502 830 03	Hochtemp. Paste	100 ml	
K = 503 426 00	Hochtemp. Fett	100 g	} segun las indicaciones de las tablas correspondientes
L = 502 566 00	Silicon sealer	100 g	
M = 504 851 00	Schleifpaste K 240	80 ml	

seguire le indicazioni sul quadro corrispondente

M 01

Kurbelgehäuse  
Crankcase  
Carter moteur  
Caja cigueñal  
Basamento motore

Tafel Nr.  
Tabl. No.  
Tavola N.

03

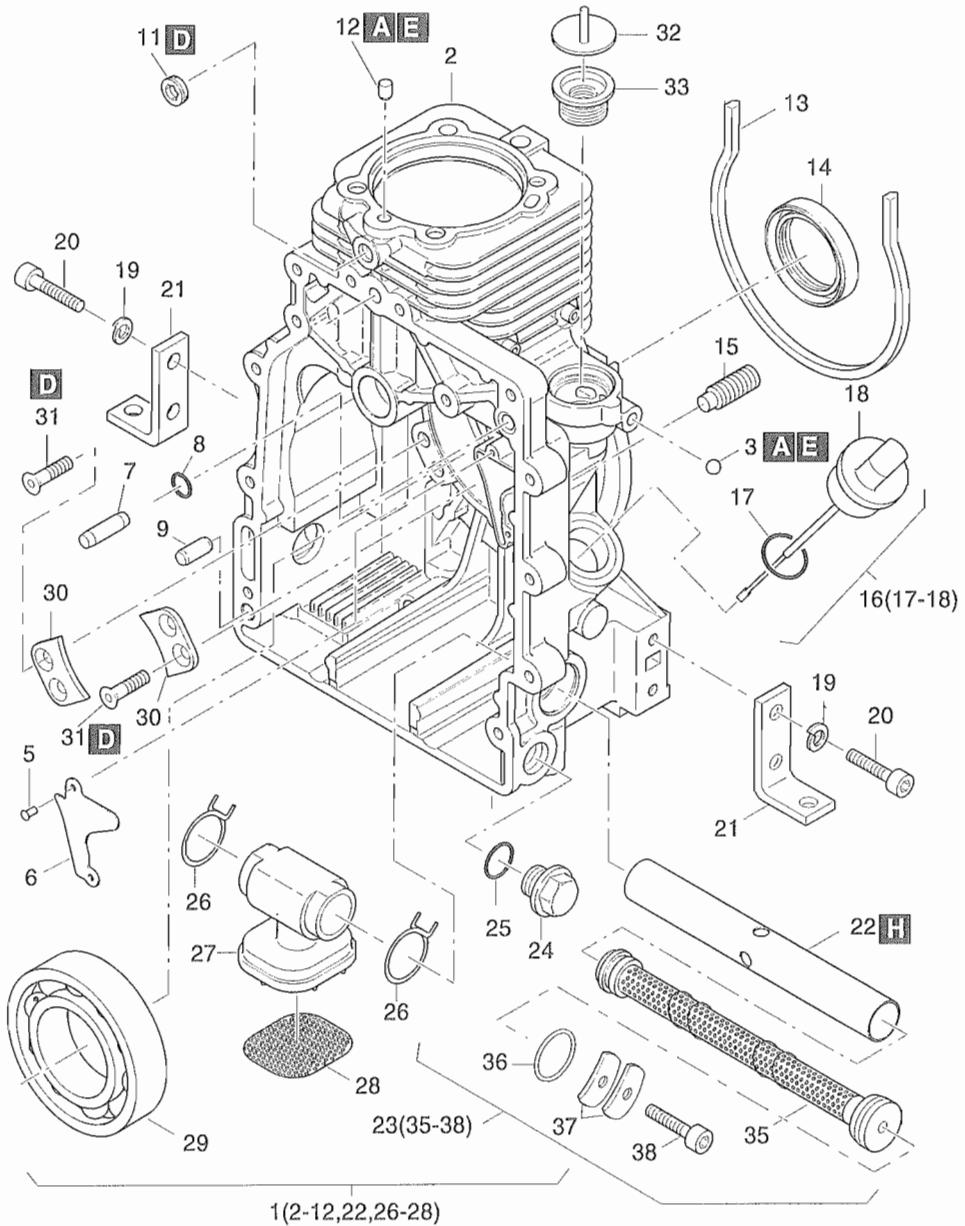

Fig.-No.	HATZ Ident-No.	Stück Qty.		P / W d / D	Bemerkungen Notes
		1B20	1B30		
1	015 522 11	1	-		
1	015 827 10	-	1		
2	-----	-	-		
3	-----	-	-		
4	-----	-	-		
5	400 026 00	2	2		3,2
6	041 054 00	1	-		
6	013 331 00	-	1		
7	505 028 01	1	1		8 m 6 x 24 DIN 6325
8	504 403 00	1	1	D1	8 x 1,5
9	502 491 01	1	1		8 m 6 x 20
10	-----	-	-		
11	500 623 00	1	1		M 10 x 1 DIN 908-5.8 A3C
12	-----	-	-		
13	040 980 00	1	-	D1	318 mm
14	504 232 00	1	-	D1	40 x 55 x 10 AS
14	504 498 00	-	1	D1	42 x 55 x 10 AS
15	041 506 00	1	1		
16	013 160 00	1	1		
17	041 250 00	1	1	D1	26 x 35 x 3
18	-----	-	-		
19	502 085 00	8	8		8 DIN128 A3C
20	041 219 00	8	8		M 8 x 35 A3C
21	040 993 02	4	4		
22	041 057 10	1	1		
23	015 427 02	1	1		
24	503 731 00	1	1	W1	AM 22 x1,5 MAGN.
25	504 698 00	1	1	D2, W4	A 22 x 27 DIN 7603 - Vf
26	050 369 00	2	2		
27	041 044 00	1	1		
28	041 045 00	1	1		
29	504 233 00	1	-		
29	504 497 00	-	1		
30	040 944 00	2	2		
31	503 280 00	4	4		AM 6 x 16 17065-8.8 Zn
32	015 558 00	1	1		

M 01

Kurbelgehäuse  
Crankcase  
Carter moteur  
Caja cigueñal  
Basamento motore

Tafel Nr.  
Tabl. No.  
Tavola N.

03

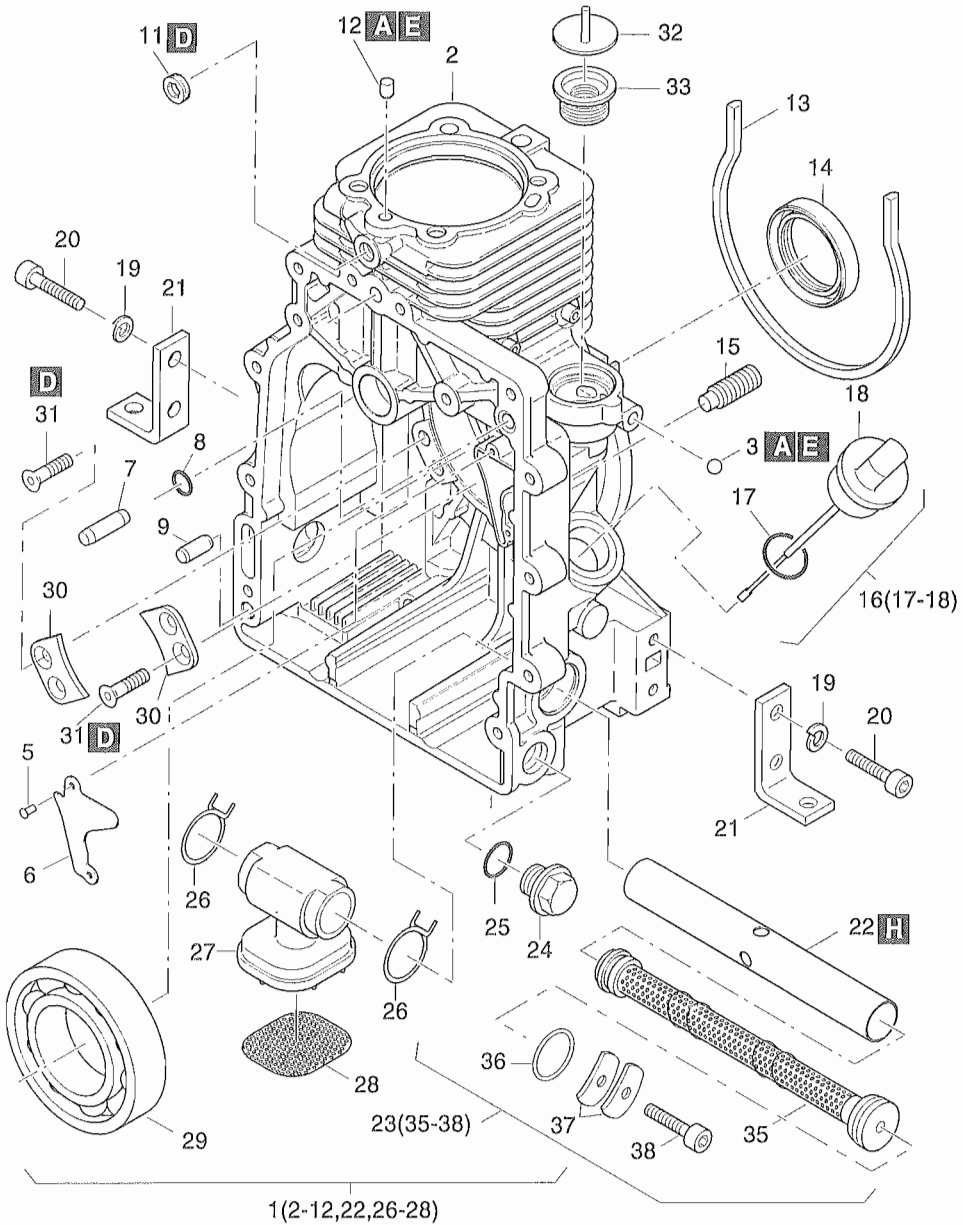

Fig.-No.	HATZ Ident-No.	Stück Qty.	P / W d / D	Bemerkungen Notes
		1B20	1B30	
33	035 687 00	1	1	
34	-----	-	-	
35	-----	-	-	
36	504 759 01	1	1	W1, D1 20 x 4
37	051 482 00	2	2	
38	501 707 00	1	1	M 6 x 16 DIN 912-8.8A3C

M 02

Kurbelwelle  
Crankshaft  
Vilebrequin  
Cigüeñal  
Albero a gomito

Tafel Nr.  
Tabl. No.  
Tavola N.

04

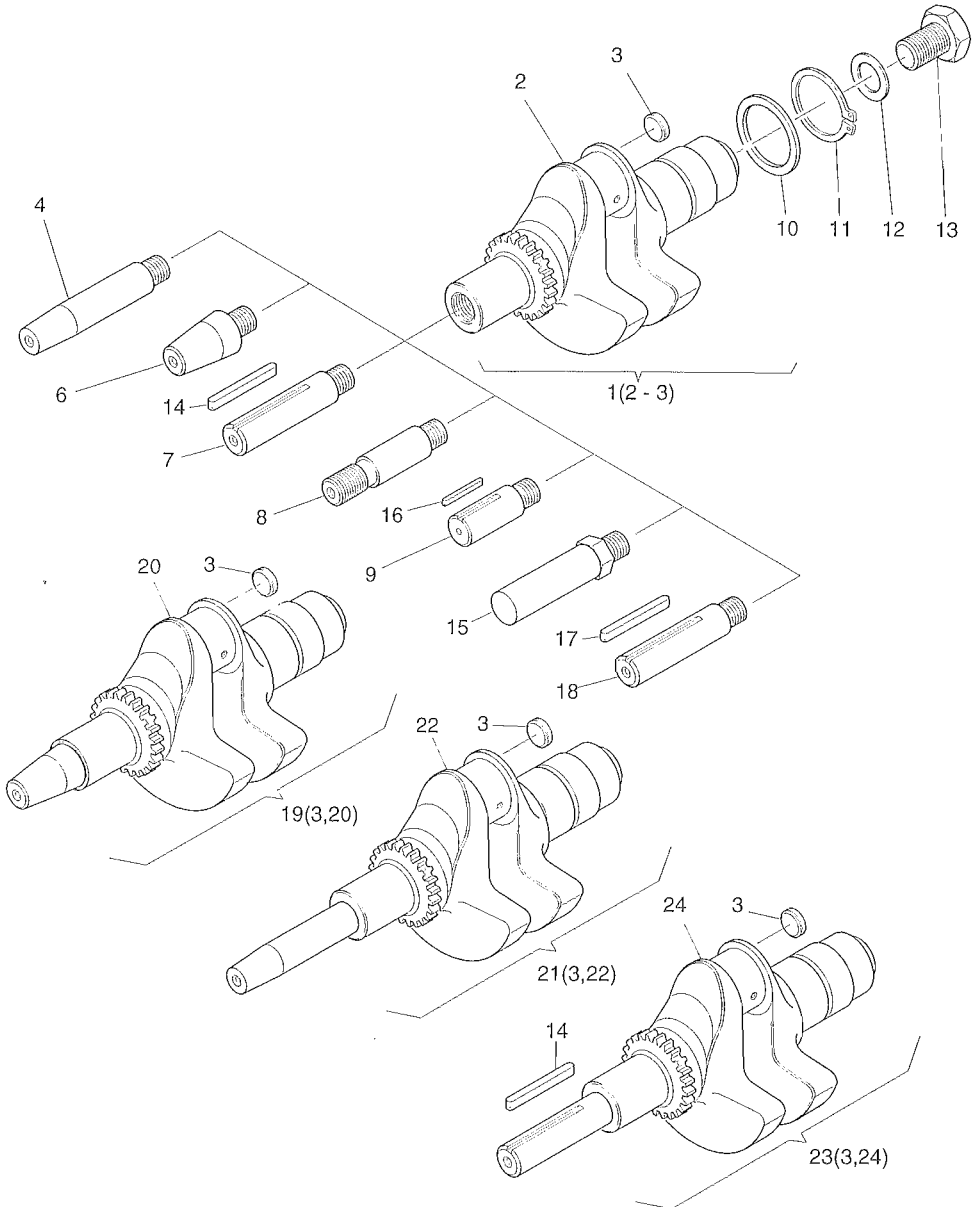

Fig.-No.	HATZ Ident-No.	Stück Qty.	P / W d / D	Bemerkungen Notes
		1B20	1B30	
1	015 527 00	1	-	
1	013 342 00	-	1	
2	-----	-	-	
3	041 253 00	1	1	
4	050 996 00	1	-	Nr. 4 SAE Generator Ø 19,8 mm
4	051 274 01	-	1	Nr. 4 SAE Generator Ø 7/8"
5	-----	-	-	
6	050 997 00	1	1	Nr. 6 ital. 23 keg., con.
6	051 427 00	-	1	keg., con. ø 25 f. Gen.
7	050 998 00	1	-	Nr. 7 - Ø 3/4" zyl., cil.
7	051 276 10	-	1	Nr. 2 - Ø 1" zyl., cil.
8	050 999 00	1	-	Nr. 8 SAE 3/4 - 16 UNF 2A
8	051 277 20	-	1	Nr. 1 - SAE Ø 1" - 14 UNS 2A
9	051 000 00	1	-	Ø 20 zyl., cil.
9	051 278 01	-	1	Ø 25 zyl., cil.
10	400 325 00	1	-	40 x 50 x 2,5 DIN 988
10	400 656 00	-	1	45 x 55 x 3,0
11	501 206 00	1	-	A 40 x 1,75 DIN 471
11	500 216 00	-	1	A 45 x 1,75 DIN 471
12	041 142 01	1	1	18,5 x 37 x 5
13	504 436 00	1	1	M 18 x 1,5 x 55 DIN 961 - 10.9
14	041 204 00	1	-	4,75 x 30
14	051 416 00	-	1	A 6,35 x 61
15	051 073 01	1	1	SW 27 mm, Ø 26,8 mm
16	504 634 00	1	-	A 5 x 5 x 36 DIN 6885
16	504 737 00	-	1	7 x 8 x 45 DIN 6885
17	504 634 00	1	1	A 5 x 5 x 36 DIN 6885
18	041 525 00	1	1	Ø 22,2 zyl., cil.
19	015 523 00	1	-	Nr. 6 ital. 23 keg., con.
19	013 339 00	-	1	Nr. 6 ital. 23 keg., con.
20	-----	-	-	
21	015 524 00	1	-	Nr. 4 SAE Generator Ø 19,8 mm
21	013 299 00	-	1	Nr. 4 SAE Generator Ø 7/8"
22	-----	-	-	
23	015 525 00	1	-	Nr. 7 Ø 3/4" zyl., cil.
23	013 341 00	-	1	Nr. 2 Ø 1" zyl., cil.
24	-----	-	-	



M 04

Nockenwelle  
Camshaft  
Arbre à cames  
Arbol de levas  
Albero a camme

Tafel Nr.  
Tabl. No.  
Tavola N.

05

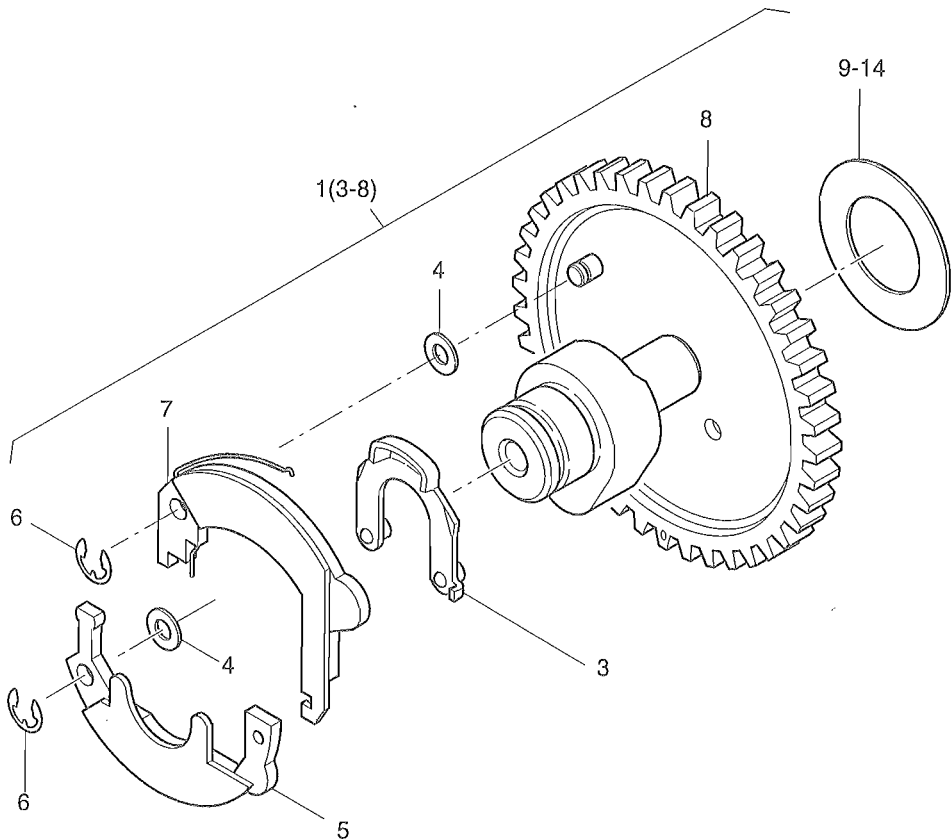

Fig.-No.	HATZ Ident-No.	Stück Qty.	P / W d / D	Bemerkungen Notes
		1B20	1B30	
1	015 035 21	0...1	0...1	
2	-----	-	-	
3	013 264 00	1	1	
4	501 232 00	2	2	5 x 10 x 0,5 DIN 988
5	013 266 00	1	1	
6	502 553 00	2	2	3,2            DIN 6799
7	013 265 01	0...1	0...1	
8	-----	-	-	
9	041 217 00	0...1	0...1	0,9 mm 23 x 38 x 0,9
10	041 121 00	0...1	0...1	1,0 mm 23 x 38 x 1,0
11	041 122 00	0...1	0...1	1,1 mm 23 x 38 x 1,1
12	041 123 00	0...1	0...1	1,2 mm 23 x 38 x 1,2
13	041 251 00	0...1	0...1	1,3 mm 23 x 38 x 1,3
14	041 252 00	0...1	0...1	1,4 mm 23 x 38 x 1,4

**M 05**

Kolben, Pleuel  
Piston, Conrod  
Piston, bielle  
Embolo, biela  
Pistone, biella

**M 06**

Zylinder  
Cylinder  
Cylindre  
Cilindro  
Cilindro

Tafel Nr.  
Tabl. No.  
Tavola N.

**06**

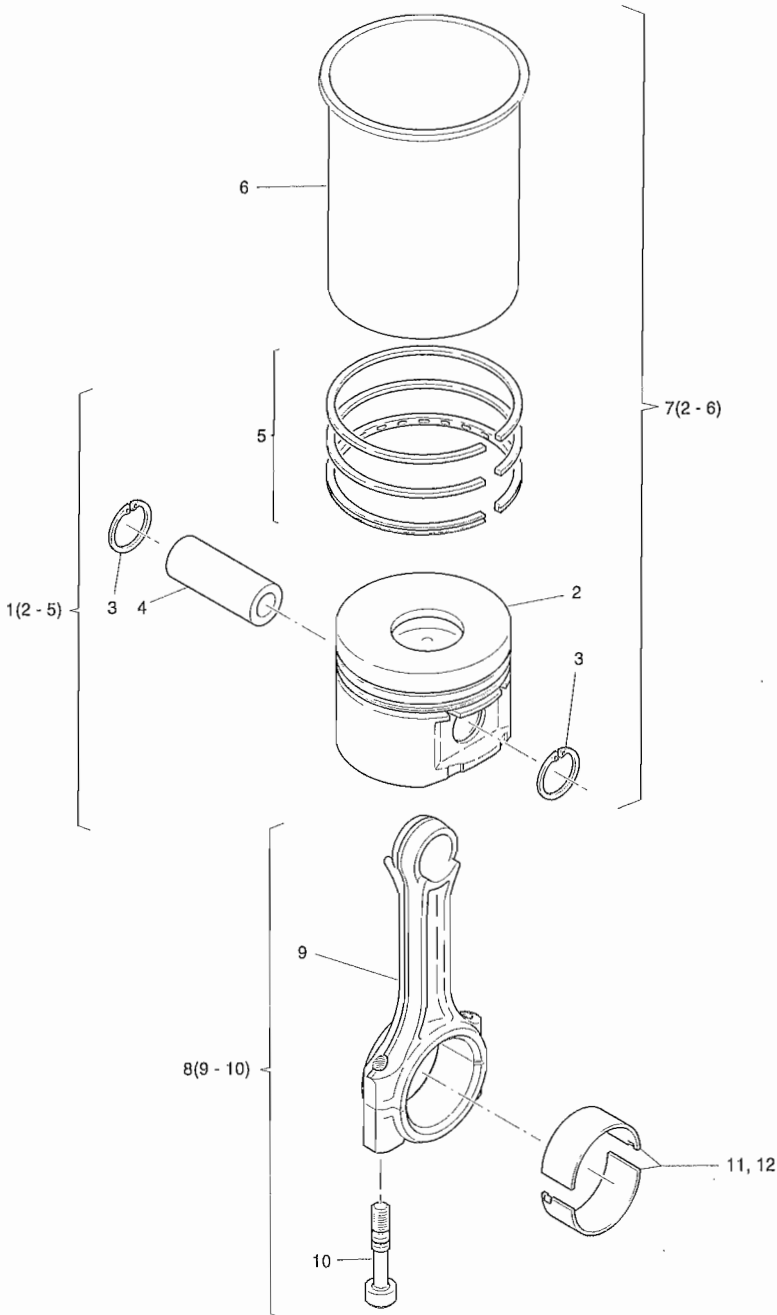

Fig.-No.	HATZ Ident-No.	Stück Qty.	P / W d / D	Bemerkungen Notes
		1B 20	1B 30	
1	013 498 00	1	-	69 mm
1	013 285 03	-	1	80 mm
2	-----	-	-	
3	504 255 00	2	-	
3	504 640 00	-	2	
4	-----	-	-	
5	013 172 00	1	-	
5	013 286 02	-	1	
6	-----	-	-	
7	015 545 10	1	-	
7	015 826 00	-	1	
8	015 001 00	1	-	
8	013 292 01	-	1	
9	-----	-	-	
10	050 469 00	2	-	
10	041 131 00	-	2	
11	015 757 00	1	-	
11	015 821 00	-	1	
12	015 819 00	1	-	-0,5 mm
12	015 820 00	-	1	-0,5 mm



Fig.-No.	HATZ Ident-No.	Stück Qty.		P / W d / D	Bemerkungen Notes
		1B20	1B30		
1	015 002 40	1	-		
1	015 298 10	-	1		
2	-----	-	-		
3	051 194 00	2	-		
3	051 295 00	-	2		
4	-----	-	-		
5	050 975 00	-	2		141 mm (M 10 - M 8)
6	050 625 00	4	-		128 mm (M 8)
6	050 974 00	-	2		148 mm (M 10)
7	050 540 00	2	-		
7	050 989 00	-	2		174,8 mm
8	041 075 00	2	-	d2	
9	050 532 00	1	-		
9	050 930 00	-	1		
10	050 533 00	1	-		
10	050 931 00	-	1		
11	504 258 00	2	2	d2	
12	040 937 00	2	2		
13	040 936 00	2	-		
13	041 135 00	-	2		
14	040 938 00	2	2		
15	504 257 00	2	2		
16	504 451 00	4	4		6 x 12 x 1,2 DIN 988
17	050 911 01	2	2		
18	505 131 00	2	2	W2	M 8 x 10 DIN 916 - 45 H
19	050 547 00	2	2		
20	050 509 00	2	-		
20	050 982 01	-	2		
21	050 612 01	4	-		8,1 x 20 x 3
21	050 993 00	-	4		10,1 x 24 x 3
22	503 643 00	4	-		M 8 DIN 934 - 10.9 A3C
22	503 966 00	-	4		M 10 DIN 934-10 A3C

M 07

Zylinderkopf  
Cylinder head  
Culasse  
Culata  
Testa

Tafel Nr.  
Tabl. No.  
Tavola N.

07

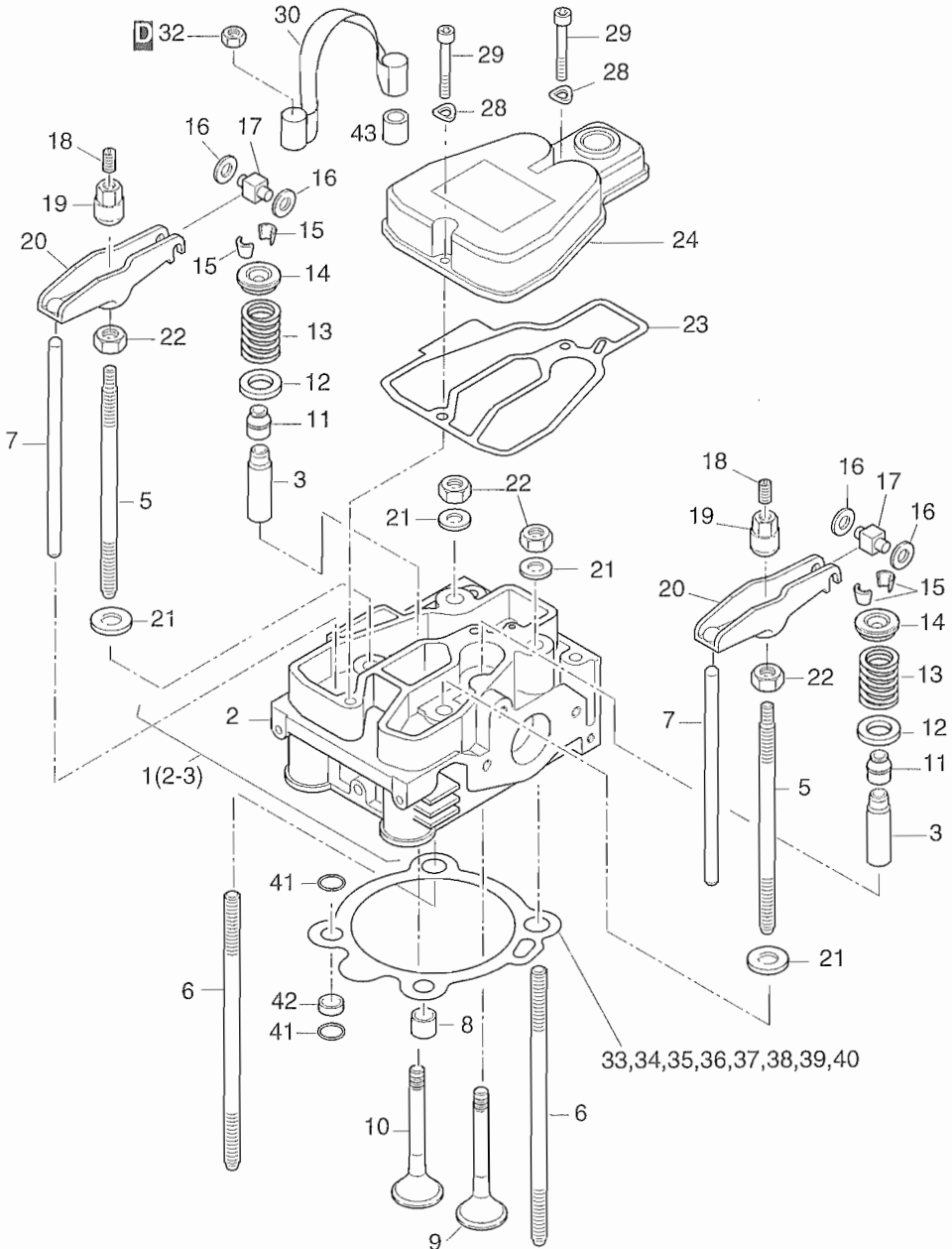

Fig.-No.	HATZ Ident-No.	Stück Qty.	P / W d / D	Bemerkungen Notes
		1B20	1B30	
23	050 557 00	1	-	d1,W4
23	050 933 01	-	1	d1,W4
24	050 473 20	1	-	
24	050 927 10	-	1	
28	500 812 00	2	2	A6
29	503 749 00	2	2	M 6 x 35
				DIN 137 - A3C
				DIN 912 - 8.8 A3C
30	041 176 00	1	-	
30	041 177 01	-	1	
31	-----	-	-	
32	501 295 00	2	-	M 8
32	500 238 00	-	2	BM 10
				DIN 985 - A3C
				DIN 439 A3C
33	050 594 00	0...1	-	0,3 mm
33	050 963 01	-	0...1	0,3 mm
34	050 595 00	0...1	-	0,4 mm
34	050 964 01	-	0...1	0,4 mm
35	050 596 00	0...1	-	d1
				0,5 mm
35	050 965 01	-	0...1	0,5 mm
36	050 597 00	0...1	-	d1
				0,6 mm
36	050 966 01	-	0...1	d1
				0,6 mm
37	050 598 00	0...1	-	0,7 mm
37	050 967 01	-	0...1	d1
				0,7 mm
38	050 599 00	0...1	-	0,8 mm
38	050 968 01	-	0...1	0,8 mm
39	050 600 00	0...1	-	0,9 mm
39	050 969 01	-	0...1	0,9 mm
40	050 601 00	0...1	-	1,0 mm
40	050 970 01	-	0...1	1,0 mm
41	504 403 00	-	4	d4
				8 x 1,5
42	041 335 00	-	2	
43	041 261 00	-	2	(10 x 12 x 9)



M 10

Ölpumpe, Regler  
Oil pump, governor  
Pompe à huile, regulateur  
Bomba de aceite, regulador  
Pompa olio, regolatore

M 32

Drehzahlverstellung  
Speed control  
Réglage régime  
Ajuste de revoluc.  
Regolatore di giri

Tafel Nr.  
Tabl. No.  
Tavola N.  
**08**

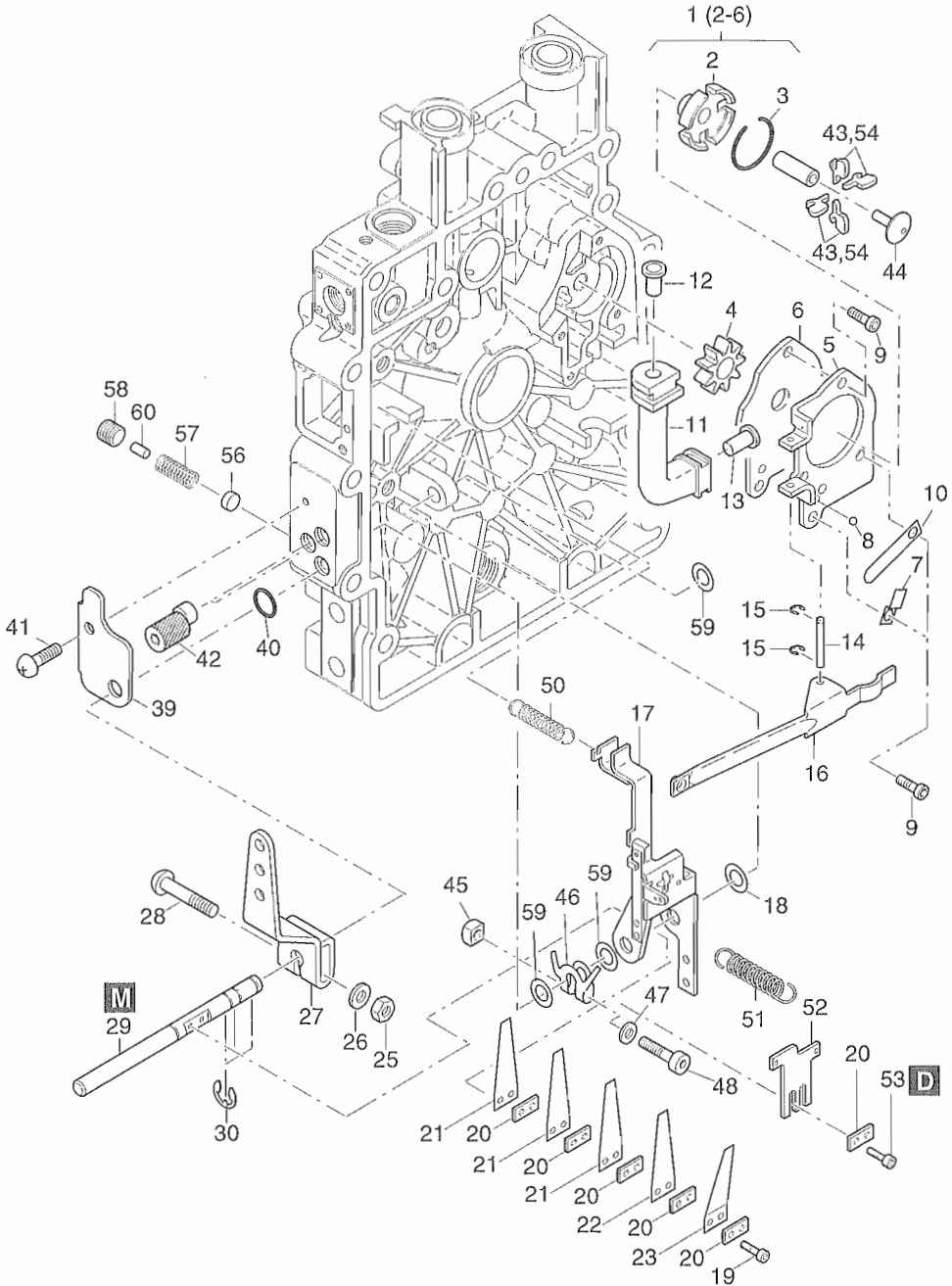

Fig.-No.	HATZ Ident-No.	Stück Qty.	P / W d / D	Bemerkungen Notes
		1B20	1B30	
1	015 302 10	1	1	
2	-----	-	-	
3	504 349 01	1	1	RB25      DIN 7993
4	-----	-	-	
5	-----	-	-	
6	-----	-	-	
7	050 971 00	1	1	
8	504 479 00	1	1	3,5 mm Kl. III
9	504 294 00	4	4	M5 x 12      DIN 6912 - 8.8
10	050 973 00	1	1	0,4 mm
11	041 029 00	1	1	
12	504 474 00	1	1	A8 x 0,5 x 12 DIN 7340 - St
13	504 475 00	1	1	A10 x 0,75 x 12 DIN 7340 - St
14	050 786 00	1	1	
15	504 348 00	2	2	1,9            DIN 6799
16	050 794 01	1	1	
17	015 304 03	1	1	
18	501 258 00	1	1	8 x 14 x 0,5 DIN 988
19	504 350 00	2	2	M 3 x 12      DIN 912-8.8
20	050 798 00	1...5	1...5	
21	051 316 00	1...2	1...3	0,2 mm
22	050 789 00	1...2	1	0,3 mm
23	051 486 00	1	1	0,4 mm      19° <
24	-----	-	-	
25	501 444 00	1	1	M 6            DIN 934 - 8 A3C
26	501 445 00	1	1	6,4            DIN 125 - St A3C
27	040 956 00	1	1	
28	039 273 00	1	1	M 6 x 32
29	050 793 01	1	1	
30	500 927 00	3	3	7              DIN 6799 A3C

Gen.-PV 78  
951 385 00

M 10

Ölpumpe, Regler  
Oil pump, governor  
Pompe à huile, regulateur  
Bomba de aceite, regulador  
Pompa olio, regolatore

M 32

Drehzahlverstellung  
Speed control  
Réglage régime  
Ajuste de revoluc.  
Regolatore di giri

Tafel Nr.  
Tabl. No.  
Tavola N.

08

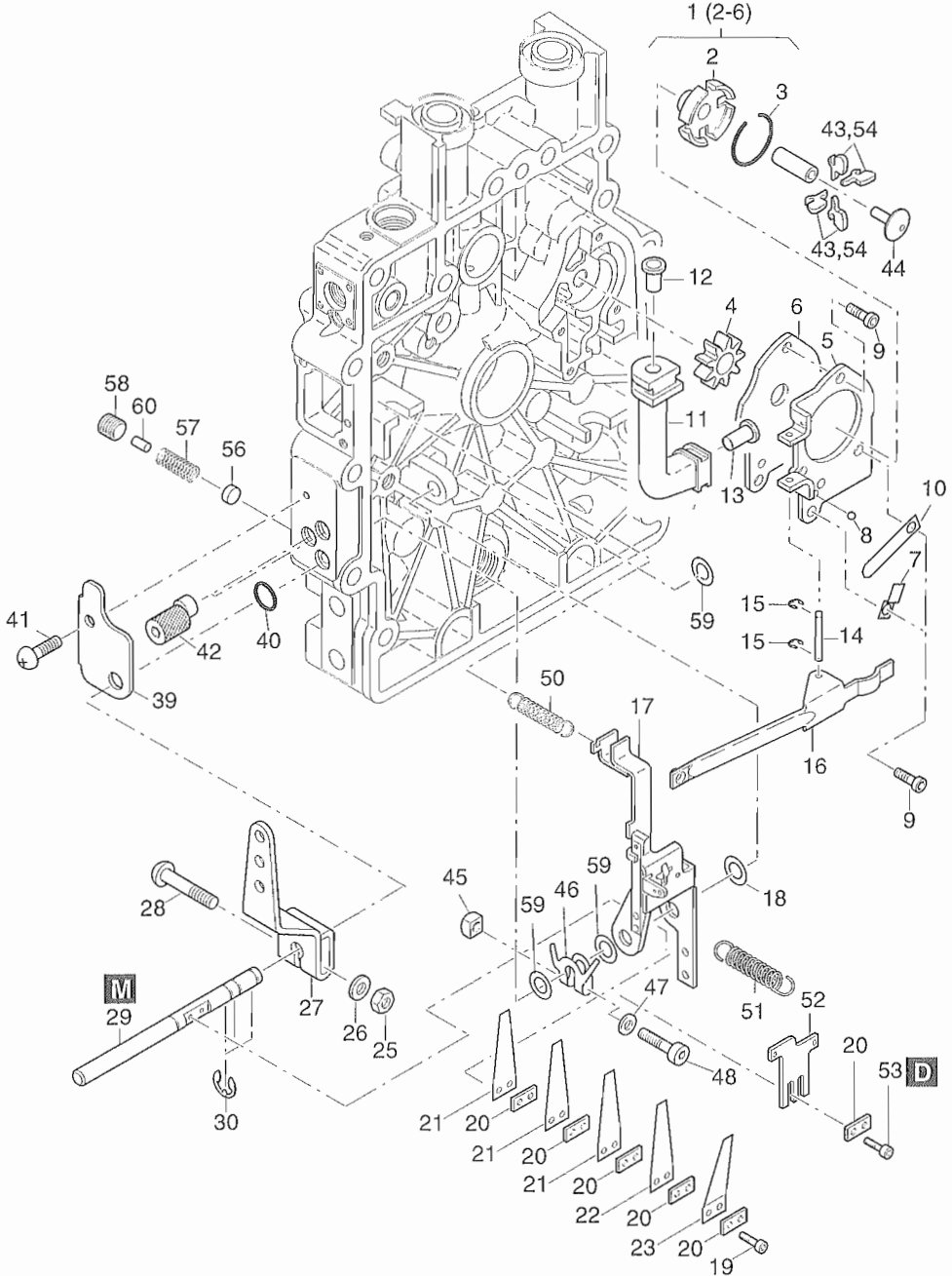

Fig.-No.	HATZ Ident-No.	Stück Qty.		P / W d / D	Bemerkungen Notes
		1B20	1B30		
39	051 784 00	1	1		
40	400 224 01	1	1	D1	8 x 2 FPM 75 MOLYKOT.
41	504 923 00	1	1		M 5 x 12 ISO 7380-10.9 Zn
42	051 788 10	2	2		
43	050 796 02	8	8		
44	050 785 02	1	1		
45	504 227 00	1	1		M 5 DIN 557-5 A3C
46	051 785 00	1	1		
47	502 163 00	1	1		5,3 DIN 125-St A3C
48	504 922 00	1	1		M 5 x 25 DIN 6912-8.8
50	040 002 00	1	1		
51	051 309 00	1	1		
52	051 308 00	1	1		
53	504 653 00	2	2		M 3 x 8 DIN 912-8.8
54	051 602 02	4	4		Gen.-PV 78
56	051 517 00	1	1		8 x 3,2 x 0,5
57	504 887 00	1	1		
58	504 757 00	1	1		M 10 x 10 DIN 913-A3C Tuf.
59	504 224 00	3	3		8 x14 x 1,0 DIN 988
60	500 579 00	1	1		4 M 6 x 8 DIN 7

M 11

Steuerdeckel  
Timing cover  
Couvercle distribution  
Tapa de mando  
Coperchio distribuzione

Tafel Nr.  
Tabl. No.  
Tavola N.

09

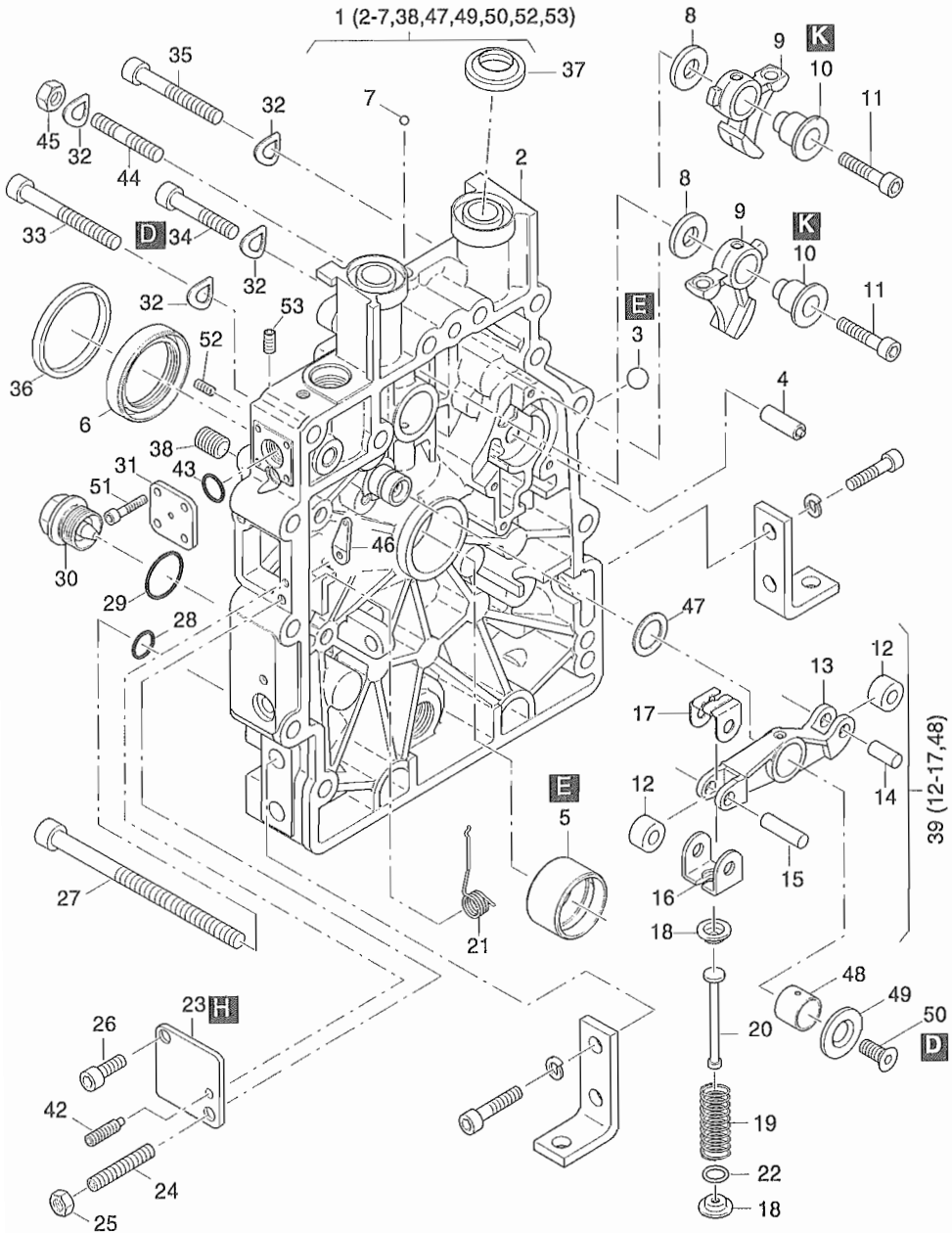

Fig.-No.	HATZ Ident-No.	Stück Qty.	P / W d / D	Bemerkungen Notes
		1B20	1B30	
1	013 195 31	1	1	
2	-----	-	-	
3	-----	-	-	
4	015 339 00	1	1	
5	050 531 00	1	1	
5	041 248 00	1	1	-0,5 mm
6	400 337 00	1	1	D1 30 x 47 x 8
7	-----	-	-	
8	037 941 00	2	2	
9	050 534 00	2	2	
10	037 942 01	2	2	
11	504 579 00	2	2	M 6 x 25 DIN 912 - 10.9
12	-----	-	-	
13	-----	-	-	
14	-----	-	-	Pos. 39 (12-17)
15	-----	-	-	
16	-----	-	-	
17	-----	-	-	
18	040 948 02	2	2	
19	040 957 00	1	1	
20	040 947 00	1	1	
21	050 952 10	1	1	
22	041 339 00	1	1	10,7 x 16 x 0,5
23	040 952 10	1	1	
24	504 489 01	1	1	M 6 x 30 DIN 913 22 H A3C Tuf.
25	501 444 00	1	1	M 6 DIN 934 - 8 A3C
26	503 842 00	1	1	M 6 x 12 DIN 912 - 8 A3C Tuf.
27	504 261 00	2	-	M 8 x 120 DIN 912 - 8.8 A3C
27	504 630 00	-	2	M 8 x 130 DIN 912 - 8.8 A3C
28	501 629 00	2	2	D2 A 8 x 14 DIN 7603 - Cu
29	504 698 00	1	1	W4, D2 A 22 x 27 DIN 7603 - Vf
30	503 731 00	1	1	W1 AM 22 x 1,5 MAGN.
31	013 517 00	1	1	

M 11

Steuerdeckel  
Timing cover  
Couvercle distribution  
Tapa de mando  
Coperchio distribuzione

Tafel Nr.  
Tabl. No.  
Tavola N.

09

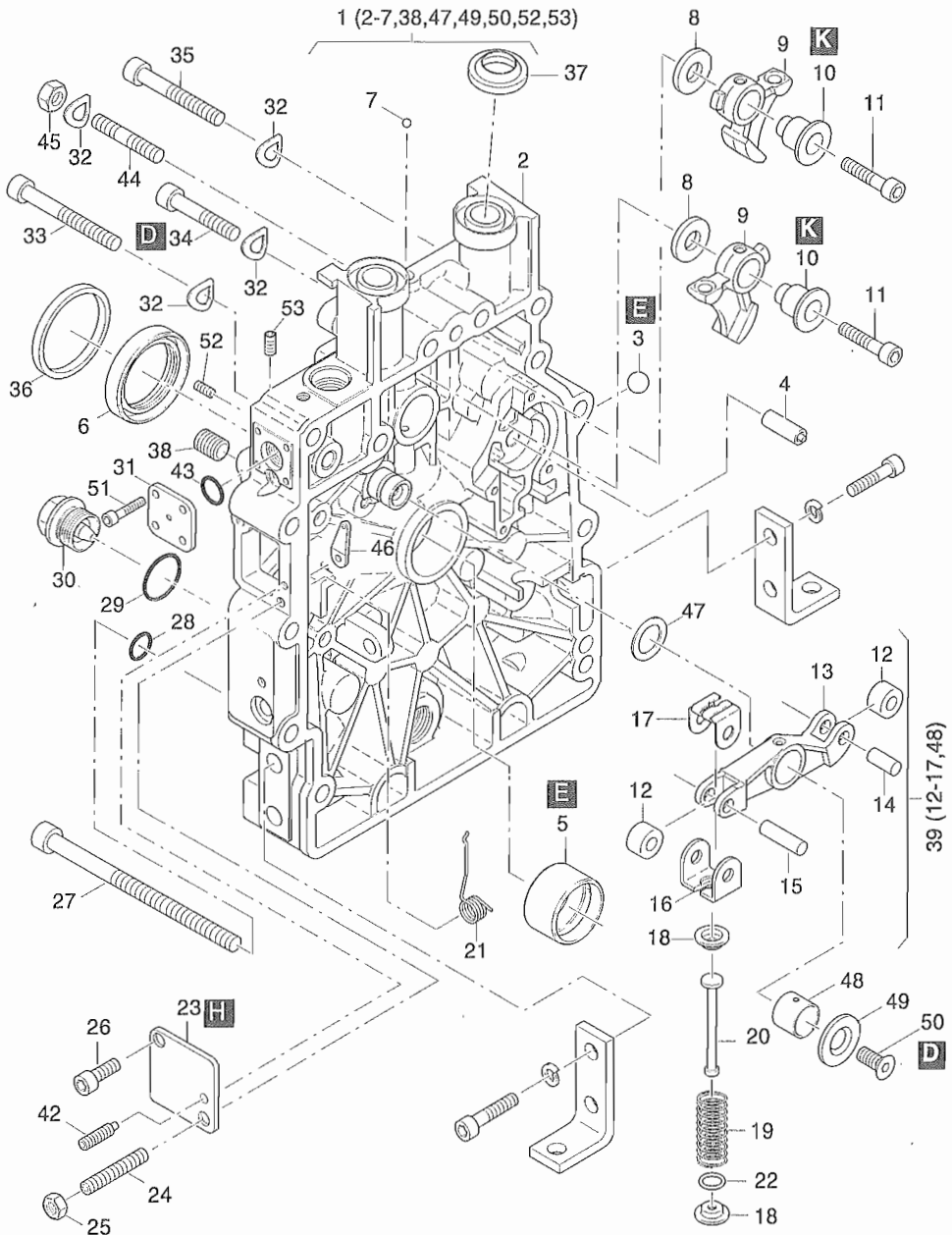

Fig.-No.	HATZ Ident-No.	Stück Qty.		P / W d / D	Bemerkungen Notes
		1B 20	1B 30		
32	500 951 00	13	13		A 8      DIN 137 A3C
33	502 488 00	1	1		M 8 x 60    DIN 912 - 8.8 A3C
34	504 534 00	2	2		M 8 x 45    DIN 912 - 8.8 A3C Tuf.
35	503 929 00	10	9		M 8 x 50    DIN 912 - 8.8 A3C
36	040 978 00	1	1		SAE A (Zentrierring)
37	041 065 00	2	2	d2	
38	503 580 00	5	5		M 8 x 10    DIN 913 - A3C Tuf.
39	013 196 10	1	1		
40	-----	-	-		
41	-----	-	-		
42	502 749 01	1	1		M 4 x 20    DIN 915-Tuf. 360 G
43	503 290 00	1	1	D1	9,5 x 2,5
44	500 387 00	-	1		M 8 x 50    DIN 835 - 8.8 A3C
45	501 480 00	-	1		M 8          DIN 934 - 8    A3C
46	051 271 00	1	1		
47	504 856 00	1	1		13 x 19 x 1
48	041 528 00	1	1		
49	041 527 01	1	1		
50	504 225 00	1	1		M 6 x 12    DIN 7991-8.8A3C
51	503 971 00	4	4		M 4 x 10    DIN 912-8.8A3C
52	504 006 00	2	2		M 5 x 10    DIN 916-45H
53	502 624 00	1	1		M 6 x 10    DIN 916-Tuf. 360 G



**M 13**

Gebälse  
Blower  
Soufflerie  
Ventilador  
Ventilatore

**M 17**

Schwungrad  
Flywheel  
Volant  
Volante  
Volano

Tafel Nr.  
Tabl. No.  
Tavola N.

**10**

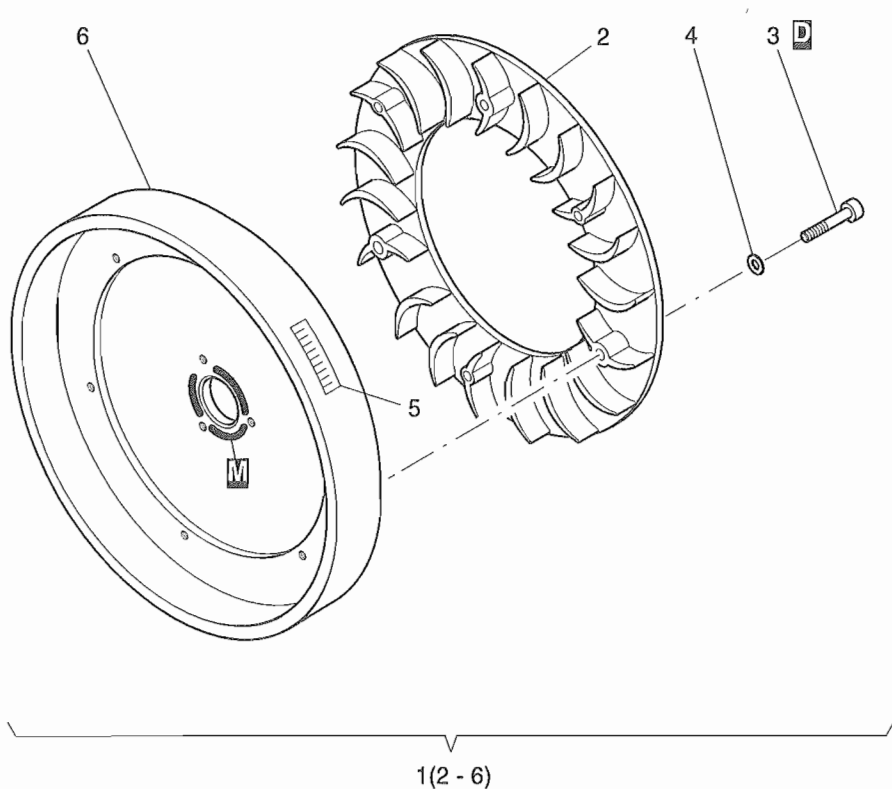

Fig.-No.	HATZ Ident-No.	Stück Qty.	P / W d / D	Bemerkungen Notes
		1B20	1B30	
1	015 797 10	1	-	
2	041 937 00	1	-	
2	041 936 00	-	1	
3	503 273 00	6	6	M 4 x 20 DIN 912 - 8.8 A3C
4	500 034 00	6	6	A 4 DIN 137
5	041 173 00	1	1	„Handstart“ OT
6	050 522 20	1	-	
6	041 103 02	-	1	

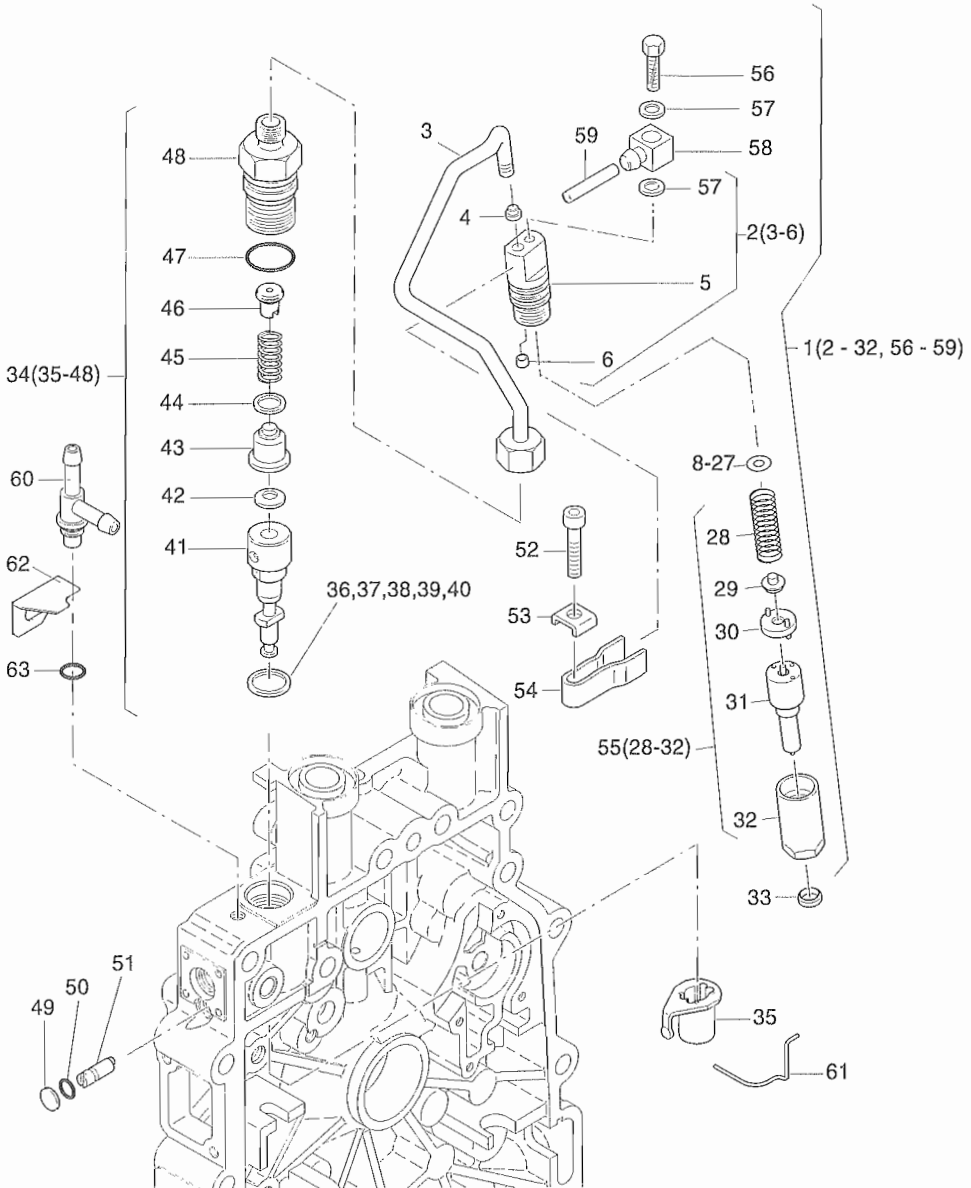

Fig.-No.	HATZ Ident-No.	Stück Qty.	P / W d / D	Bemerkungen Notes
		1B20	1B30	
1	016 216 10	1	-	
1	013 288 00	-	1	
2	015 771 10	1	-	
2	015 828 00	-	1	
3	-----	-	-	
4	050 961 01	0...1	0...1	4,9 mm
4	050 706 01	0...1	0...1	5,3 mm
5	-----	-	-	
6	050 815 00	0...1	0...1	BOSCH
7	-----	-	-	
8	504 364 00	0...1	0...1	1,00 mm
9	504 365 00	0...1	0...1	1,04 mm
10	504 366 00	0...1	0...1	1,10 mm
11	504 367 00	0...1	0...1	1,14 mm
12	504 368 00	0...1	0...1	1,20 mm
13	504 369 00	0...1	0...1	1,24 mm
14	504 370 00	0...1	0...1	1,30 mm
15	504 371 00	0...1	0...1	1,34 mm
16	504 372 00	0...1	0...1	1,40 mm
17	504 373 00	0...1	0...1	1,44 mm
18	504 374 00	0...1	0...1	1,50 mm
19	504 375 00	0...1	0...1	1,54 mm
20	504 376 00	0...1	0...1	1,60 mm
21	504 377 00	0...1	0...1	1,64 mm
22	504 378 00	0...1	0...1	1,70 mm
23	504 379 00	0...1	0...1	1,74 mm
24	504 380 00	0...1	0...1	1,80 mm
25	504 381 00	0...1	0...1	1,84 mm
26	504 382 00	0...1	0...1	1,90 mm
27	504 383 00	0...1	0...1	1,94 mm
28	-----	-	-	
29	-----	-	-	
30	-----	-	-	
31	504 893 00	1	-	P1
31	504 680 00	-	1	P1
32	-----	-	-	
33	050 705 00	1	1	d1

} s. 951 258 01

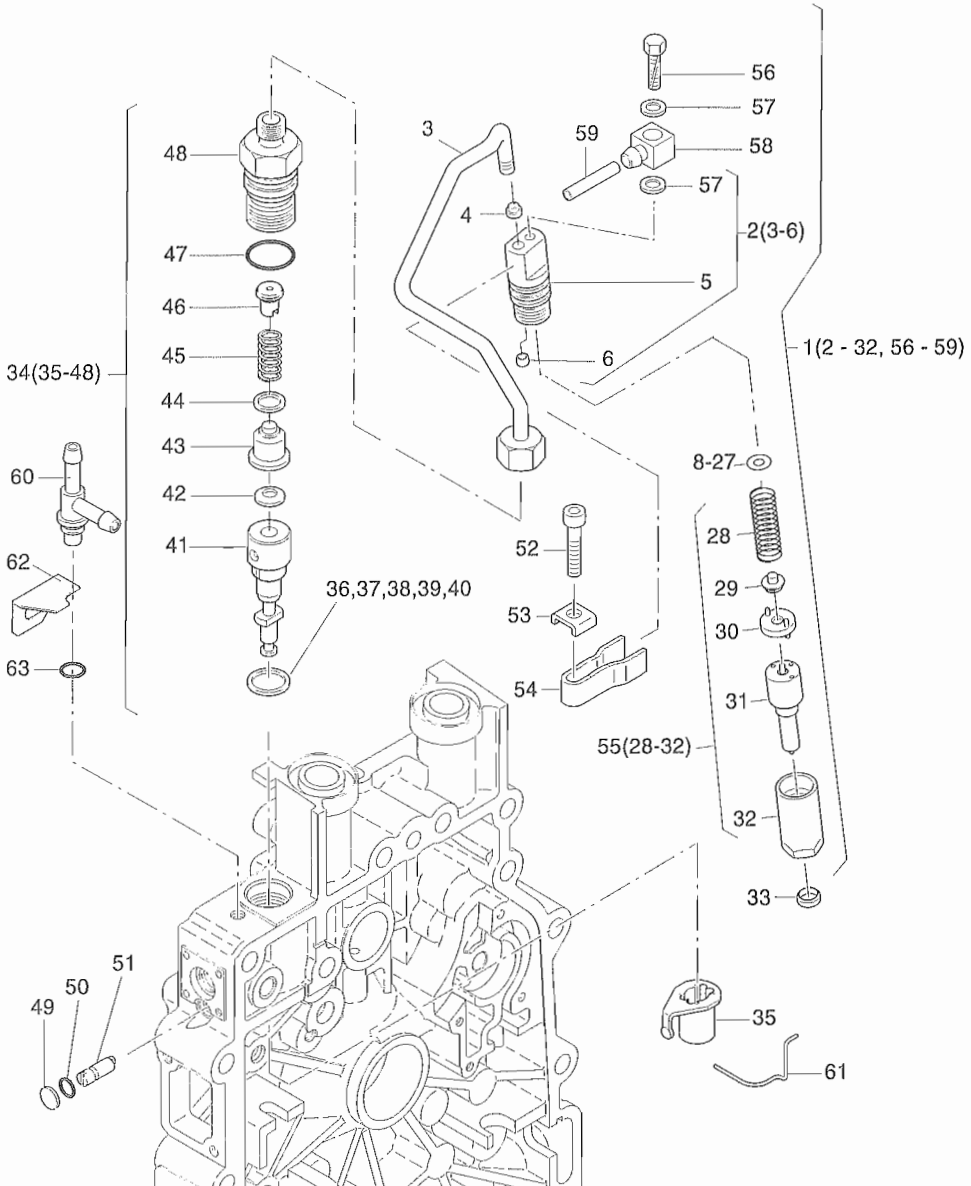

Fig.-No.	HATZ Ident-No.	Stück Qty.		P / W d / D	Bemerkungen Notes
		1B20	1B30		
34	013 222 10	1	-		
34	015 829 00	-	1		
35	013 308 01	1	1		
36	040 963 00	0...1	0...1		0,2 mm
37	040 964 00	0...1	0...1		0,3 mm
38	040 965 00	0...1	0...1		0,4 mm
39	040 966 00	0...1	0...1		0,5 mm
40	040 967 00	0...1	0...1		0,6 mm
41	-----	-	-		
42	041 652 00	-	1		8
43	-----	-	-		
44	504 769 00	1	1		9,5 x 13 x 0,5
45	-----	-	-		
46	-----	-	-		
47	504 892 00	1	1		17 x 2
48	504 459 00	1	1		
49	504 760 00	1	1		8            DIN 470 Al
50	503 301 00	1	1		4 x 1,2
51	040 977 10	1	1		
52	503 239 00	1	1		M 6 x 30    DIN 912 - 8.8 A3C
53	050 893 00	1	1		6,4
54	050 567 00	1	1		
55	016 554 00	1	-		
55	013 289 00	-	1		
56	504 645 00	1	1		AM 4 x 16    DIN 7513 St. Zn
57	501 108 00	2	2		A4 x 8        DIN 7603-Cu
58	051 290 00	1	1		
59	052 150 00	1	1		2,5 x 195
59	052 187 00	1	1		2,5 x 195 RME
60	051 830 00	1	1		
61	041 618 00	1	1		
62	051 831 00	1	1		
63	501 543 00	1	1	D1	7,5 x 1,5

M 15

Reversierstarter  
Recoil starter  
Demarreur reversible  
Arrancador reversible  
Avviamento a strappo

Tafel Nr.  
Tabl. No.  
Tavola N.

12

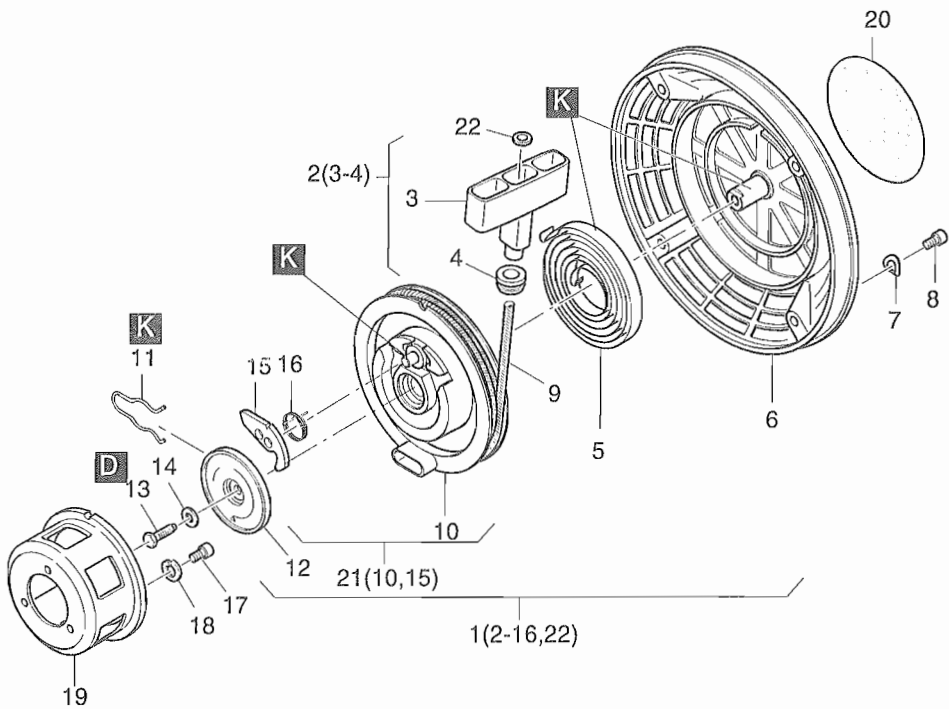

Fig.-No.	HATZ Ident-No.	Stück Qty.	P / W d / D	Bemerkungen Notes
		1B20	1B30	
1	015 150 02	1	1	
2	014 978 00	1	1	
3	-----	-	-	
4	036 652 00	1	1	
5	050 452 01	1	1	
6	015 693 00	1	1	
7	500 812 00	4	4	A6 DIN137
8	500 627 00	4	4	M 6 x 10 DIN 912 - 8.8
9	050 889 01	1	1	1750 mm
10	-----	-	-	
11	050 449 01	1	1	
12	050 450 01	1	1	
13	501 463 00	1	1	M 6 x 18 DIN 933 - 8.8 A3C
14	501 656 00	1	1	6,5 x 14 DIN 6904 - A3C
15	050 448 00	1	1	
16	050 613 00	1	1	
17	500 627 00	3	3	M 6 x 10 DIN 912 - 8.8
18	501 709 00	3	3	6 DIN 128 - A3C
19	504 458 00	1	1	
20	051 091 00	1	1	
21	015 488 00	1	1	
22	505 146 00	1	1	5,3 DIN 9021 PA 6.6



Luftführung - 1B20  
 Air ducting - 1B20  
 Carter ventilation - 1B20  
 Conducción de aire - 1B20  
 Carter ventilatore - 1B20

Tafel Nr.  
 Tabl. No.  
 Tavola N.

**M 26**

**13**

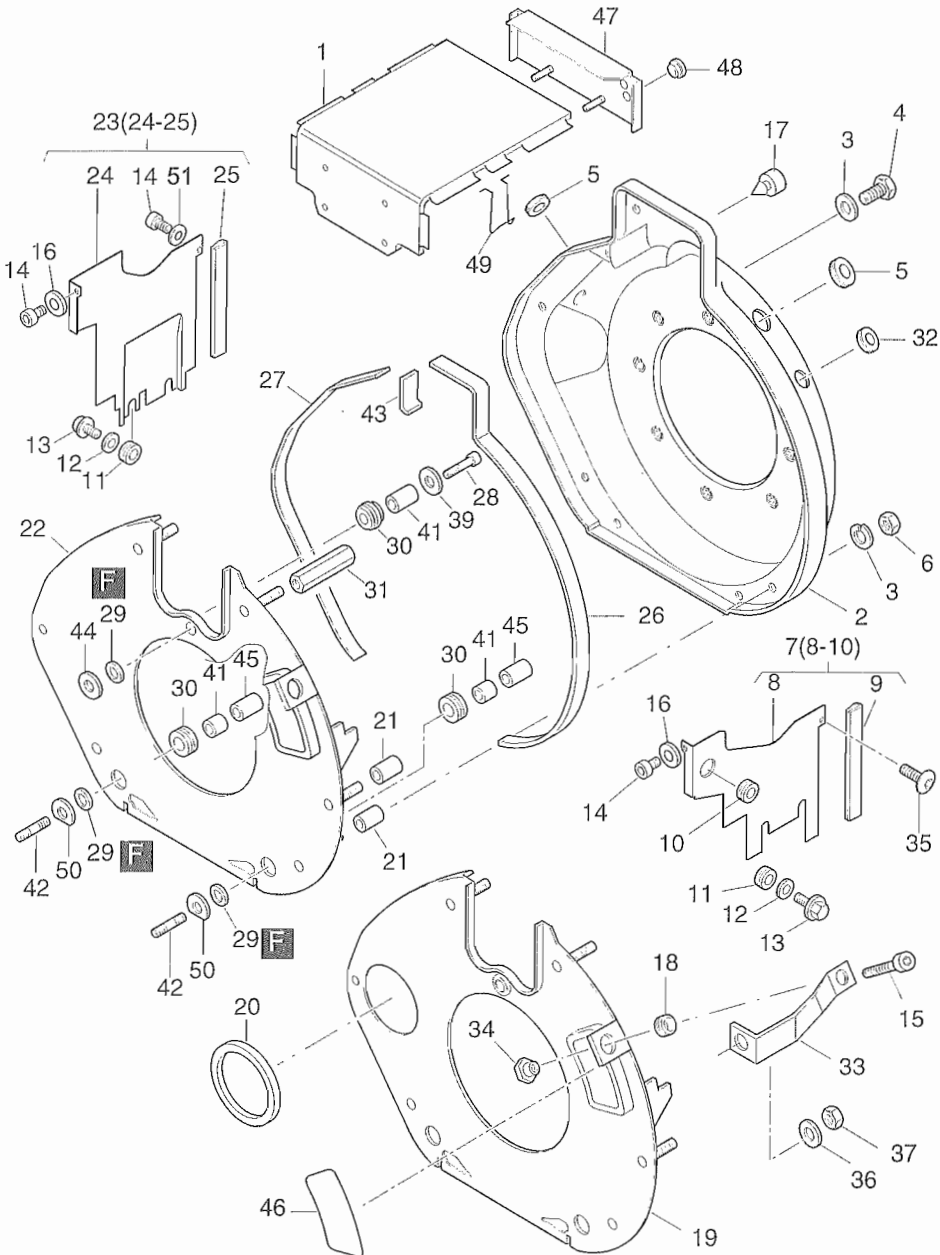

Fig.-No.	HATZ Ident-No.	Stück Qty.	P / W d / D	Bemerkungen Notes
1B20				
1	015 335 04	1		
2	013 168 00	1		
3	501 709 00	7		6          DIN 128 - A3C
4	501 463 00	1		M 6 x 18    DIN 933 - 8.8 A3C
5	504 617 00	2		
6	501 444 00	6		M 6          DIN 934 - 8 A3C
7	013 166 00	1		
8	-----	-		
9	040 976 00	1		107 mm
10	503 348 00	1		
11	501 638 01	4		
12	504 416 00	3		4,3          DIN 9021 - A3C 140HV
13	504 454 00	3		M 4 x 10 St 8.8 A3A DIN 7500
14	504 742 00	3		M 6 x 16    DIN 912-8.8 Tuf.360
15	501 707 00	1		M 6 x 16    DIN 912 - 8.8 A3C
16	501 445 00	2		6,4          DIN 125-StA3C
17	503 926 10	2		
18	503 928 00	1		
19	016 070 01	1		E-Start
20	040 995 00	1		
21	041 390 00	5		6,5 x 12 x 18
22	016 071 00	1		
23	013 165 00	1		
24	-----	-		
25	040 976 00	1		107 mm
26	041 245 00	1		470 mm
27	041 246 00	1		388 mm
28	501 708 00	1		M 6 x 25    DIN 912 - 8.8 A3C
29	035 755 00	3		
30	009 214 00	3		
31	041 244 00	1		57 mm
32	504 533 00	1		
33	015 995 00	1		
34	041 232 00	1		M 6
35	504 950 00	1		M 6 x 12    DIN 7380-10.9 A3C
36	500 951 00	1		A 8          DIN 137 A3C

# M 26

Luftführung - 1B20  
Air ducting - 1B20  
Carter ventilation - 1B20  
Conducción de aire - 1B20  
Carter ventilatore - 1B20

Tafel Nr.  
Tabl. No.  
Tavola N.

13

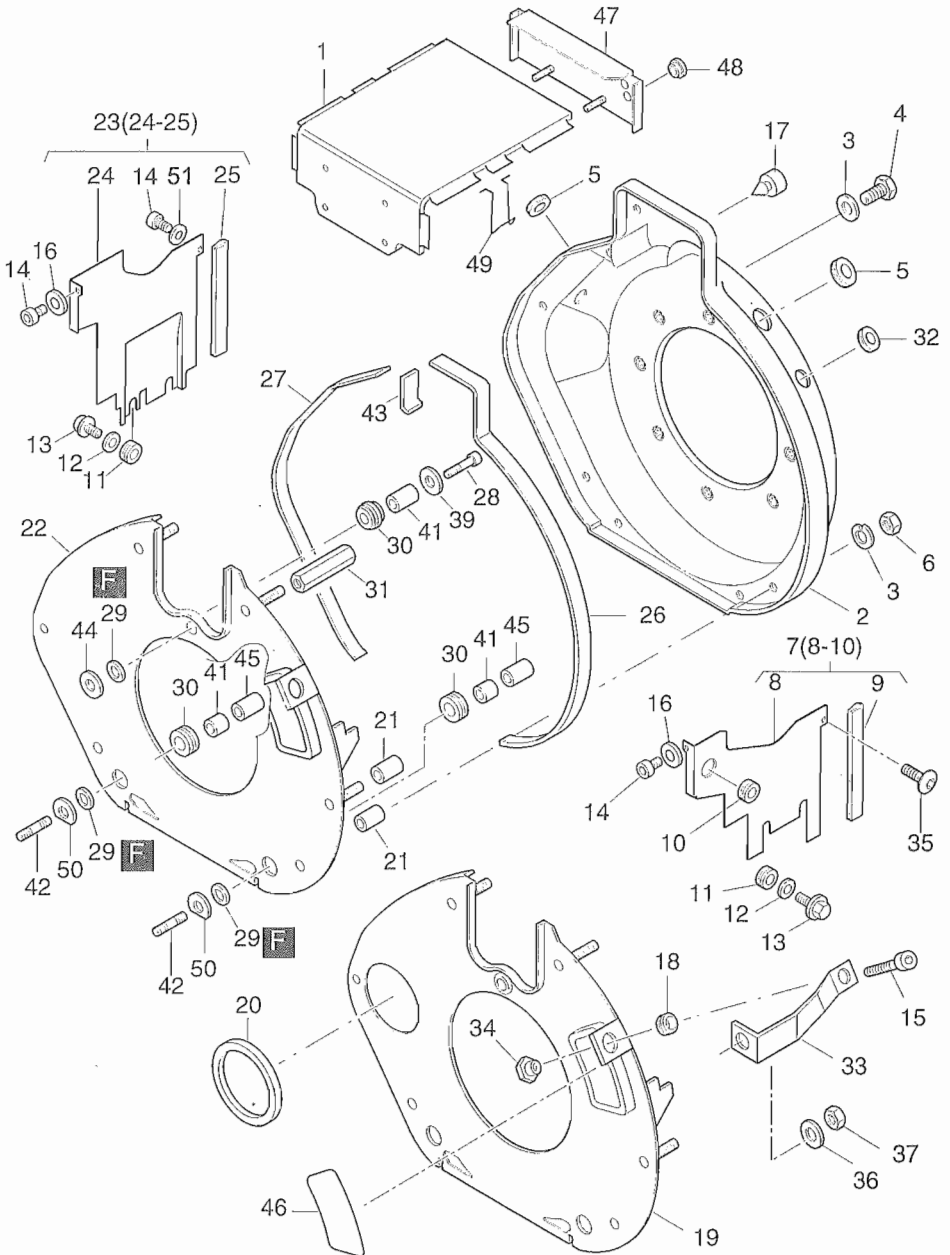

Fig.-No.	HATZ Ident-No.	Stück Qty.	P / W d / D	Bemerkungen Notes
1B20				
37	503 447 00	1		M 8      DIN 936 - 5 A3C
38	-----	-		
39	501 709 00	1		6          DIN128 A3C
40	-----	-		
41	041 191 00	3		6 x 8 x 14
42	504 581 00	2		M 6 x 45    DIN 835 - 8.8 A3C
43	050 073 00	1		48 mm
44	040 420 00	1		6,5 x 22,5 x 1
45	041 390 00	2		6,5 x 12 x 18
46	041 138 00	1		
47	015 793 00	1		
48	503 348 00	2		
49	051 441 00	1		
50	041 453 00	2		
51	040 606 00	1		6,4 x 16 x 1,5A3C

Luftführung - 1B30  
 Air ducting - 1B30  
 Carter ventilation - 1B30  
 Conducción de aire - 1B30  
 Carter ventilatore - 1B30

Tafel Nr.  
 Tabl. No.  
 Tavola N.

14

M 26

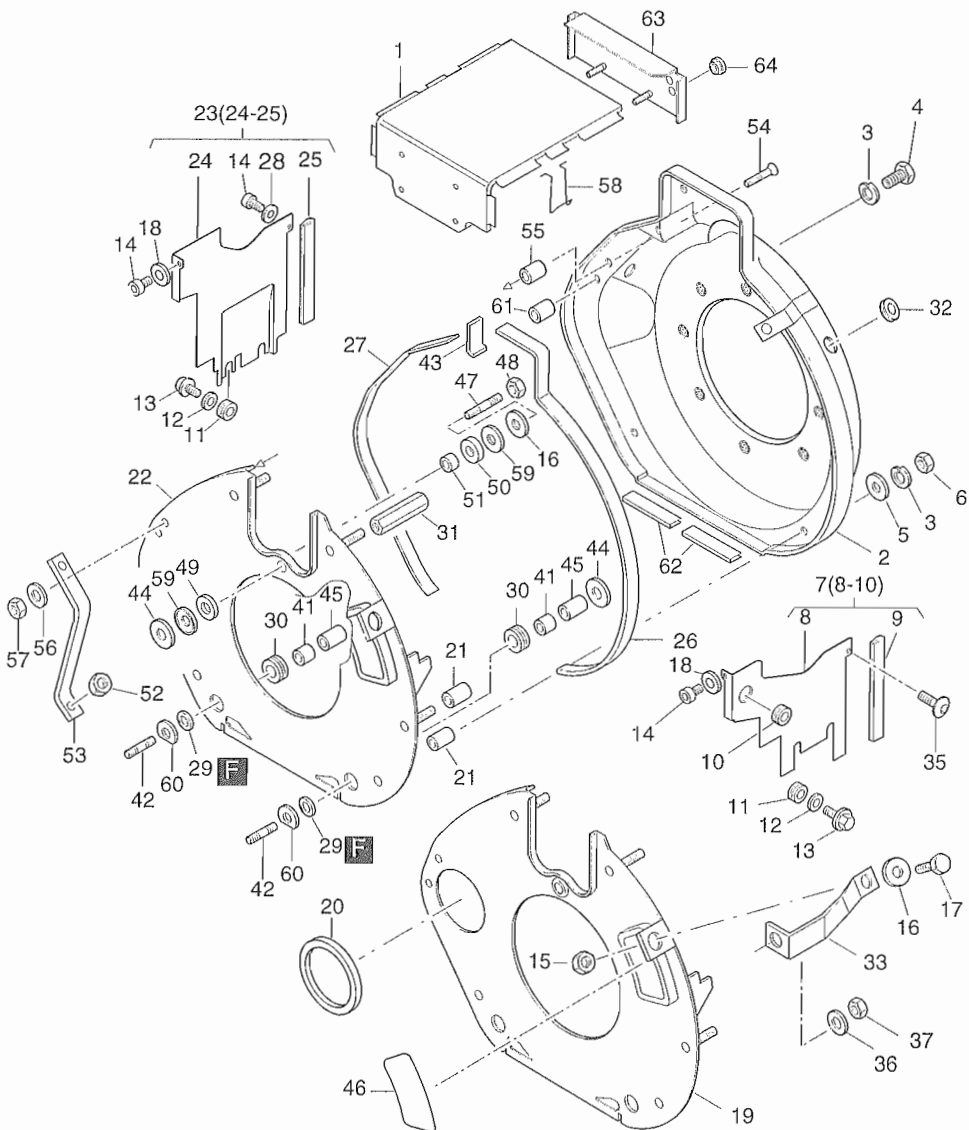

Fig.-No.	HATZ Ident-No.	Stück Qty.	P / W d / D	Bemerkungen Notes
1B30				
1	015 514 01	1		
2	015 513 20	1		
3	501 709 00	7		6 DIN 128 - A3C
4	501 463 00	1		M 6 x 18 DIN 933 - 8.8 A3C
5	501 200 00	2		A 6,4 DIN 9021 - A3C
6	501 444 00	6		M 6 DIN 934 - 8 A3C
7	013 263 00	1		
8	-----	-		
9	051 289 00	1		80 mm
10	503 348 00	1		
11	501 638 01	3		
12	504 416 00	3		4,3 DIN 9021 - A3C 140HV
13	504 454 00	3		M 4 x 10 St 8.8 A3ADIN 7500
14	504 742 00	3		M 6 x 16 DIN 912-8.8 Tuf. 360
15	501 444 00	1		M 6 DIN 934 - 8 A3C
16	501 143 00	2		6,4 DIN 7349 A3C
17	501 771 00	1		M 6 x 16 DIN 933 - 8.8 A3C
18	501 445 00	2		6,4 DIN 125-StA3C
19	013 268 10	1		E-Start
20	040 995 00	1		
21	051 975 00	4		6,5 x 12 x 20
22	013 267 10	1		
23	013 262 00	1		
24	-----	-		
25	041 115 00	1		119 mm
26	051 081 00	1		495 mm
27	041 246 00	1		388 mm
28	040 606 00	1		6,4 x 16 x 1,5A3C
29	035 755 00	2		
30	009 214 00	2		
31	051 981 00	1		59 mm
32	504 533 00	1		
33	015 996 10	1		
34	-----	-		
35	504 950 00	1		M 6 x 12 DIN 7380-10.9 A3C

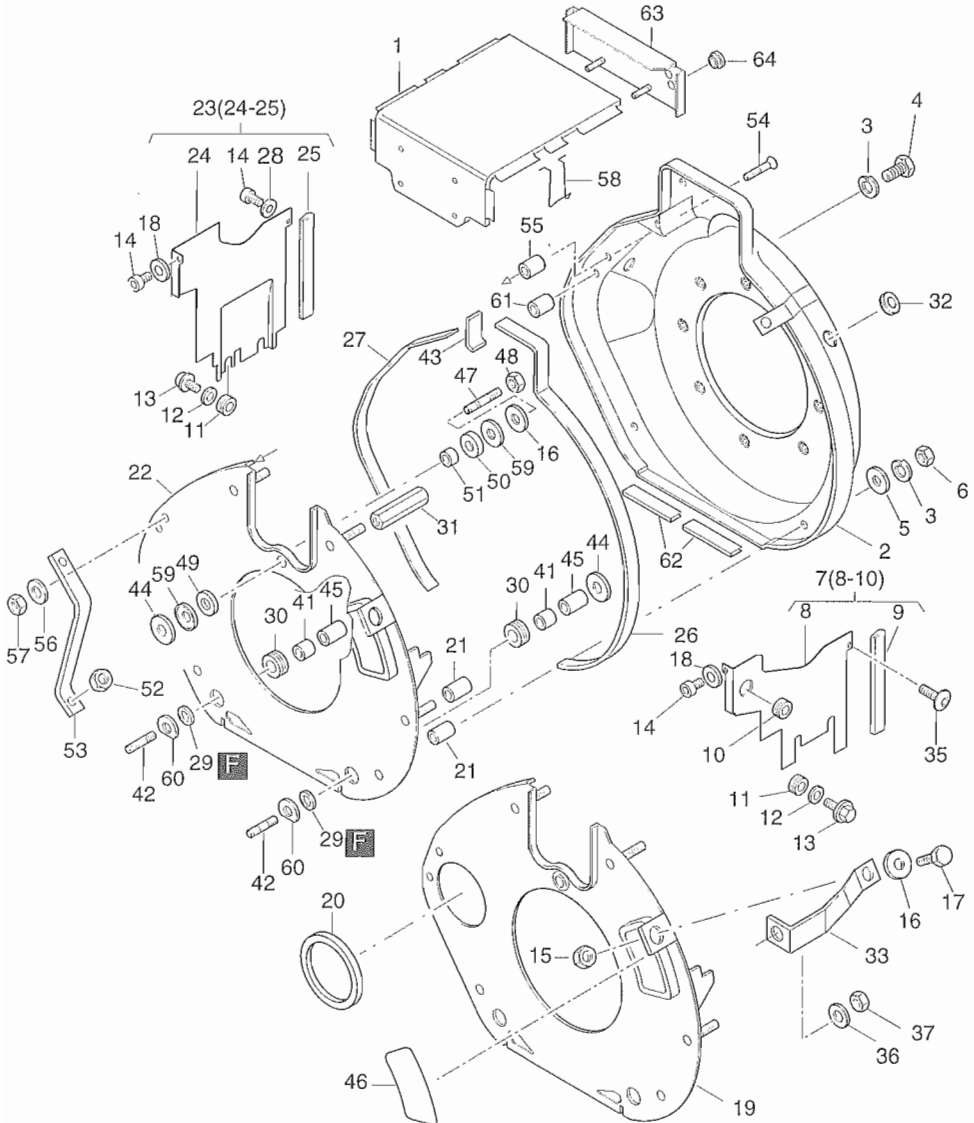

Fig.-No.	HATZ Ident-No.	Stück Qty.	P / W d / D	Bemerkungen Notes
1 B 30				
36	500 951 00	1	A 8	DIN 137 A3C
37	503 447 00	1	M 8	DIN 936 - 5 A3C
38	-----	-		
39	-----			
40	-----	-		
41	041 191 00	2		6 x 8 x 14
42	504 581 00	2	M 6 x 45	DIN 835 - 8.8 A3C
43	051 982 00	1		48 mm
44	040 420 00	3		6,5 x 22,5 x 1
45	040 984 00	2		7 x 12 x 16,3
46	041 167 00	1		
47	504 644 01	1	M 6 x 35	DIN 939- 8.8 A3C Tuf.
48	400 283 00	1	M 6	SSN 440-8
49	051 338 00	1		16 x 25 x 4
50	051 339 00	1		16 x 25 x 8
51	051 327 00	1		6,5 x 17 x 11,5
52	501 480 00	1	M 8	DIN 934-8 A3C
53	051 330 01	1		
54	504 450 00	1	M 6 x 35	DIN 7991 - 8.8 A3C
55	051 328 10	1		7 x 12 x 18,3
56	501 709 00	1	6	DIN 128A3C
57	501 444 00	1	M 6	DIN 934-8A3C
58	051 458 00	1		
59	050 976 00	2		
60	041 453 00	2		
61	041 390 00	1		6,5 x 12 x 18
62	041 621 00	2		75 mm
63	016 035 00	1		
64	503 348 00	2		



**M 31**

Kurbelgehäusentlüftung  
Crankcase breathing system  
Reniflard  
Purgador  
Sfiato basamento

Tafel Nr.  
Tabl. No.  
Tavola N.

**15**

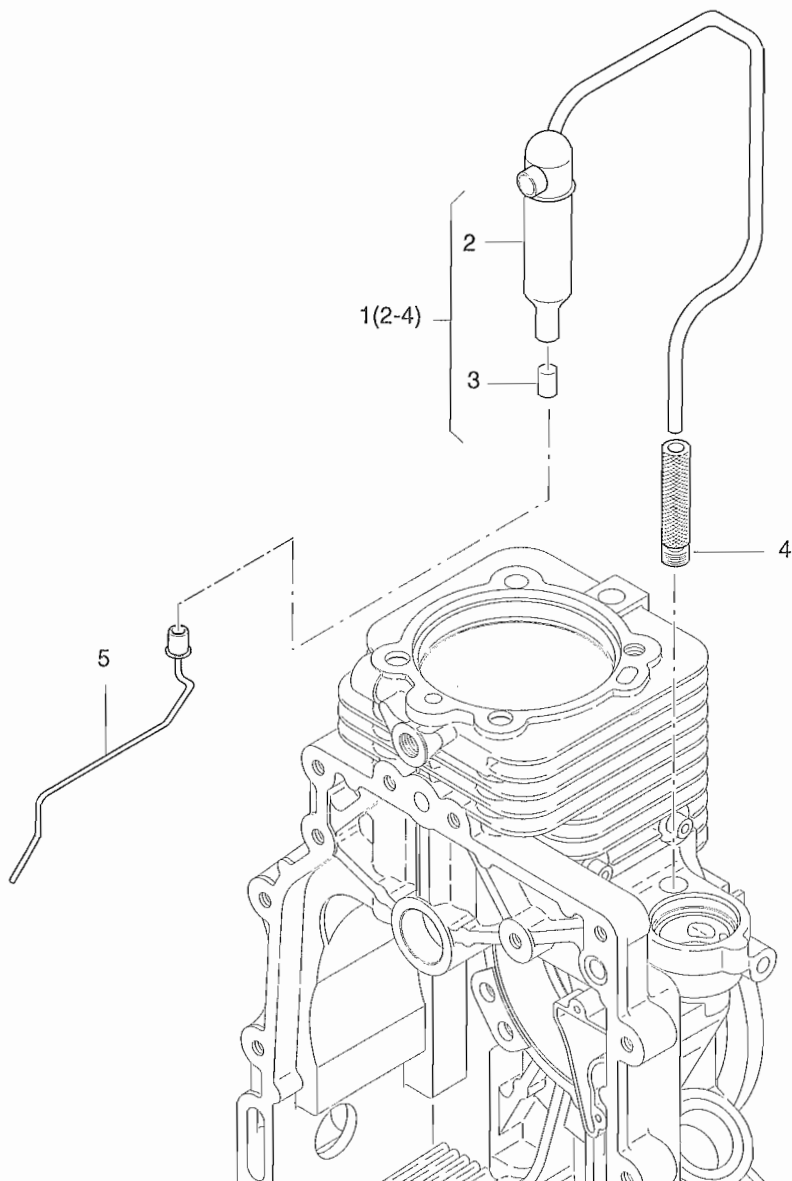

Fig.-No.	HATZ Ident-No.	Stück Qty.		P / W d / D	Bemerkungen Notes
		1B20	1B30		
1	015 564 02	1	-		
1	015 992 01	-	1		
2	-----	-	-		
3	051 029 00	1	1		Filter, Filtre, Filtro
4	016 179 00	1	1	D1	
5	015 516 00	1	1		



Fig.-No.	HATZ Ident-No.	Stück Qty.	P / W d / D	Bemerkungen Notes
		1B20	1B30	
1	015 788 30	1	-	3 l
1	015 886 20	-	1	5 l
2	015 353 02	1	1	kpl. cpl.
3	505 008 00	1	1	8            DIN 6799
4	016 289 00	1	1	
5	-----	-	-	
6	051 906 00	1	-	3,5 x 260
6	051 899 00	-	1	3,5 x 300
7	015 349 00	1	1	
8	503 998 01	3	3	11,3
9	050 840 10	1	1	
10	-----	-	-	
11	050 864 01	1	1	
12	504 408 00	2	2	
12	504 612 00	2	2	RME
13	039 621 00	1	-	3,5 x 160
13	051 883 00	-	1	3,5 x 170
13	051 901 00	1	1	3,5 x 160 RME
14	051 232 00	1	1	3,5 x 40
15	008 055 01	1	1	
18	051 304 00	1	1	
18	051 333 00	1	1	RME
19	504 409 00	2	2	
19	504 611 00	2	2	RME
20	050 856 00	1	1	1 x 3 x 85
21	502 319 00	2	2	M 8 x 25    DIN 835 - 8.8 A3C
22	051 098 10	4	4	8,2 x 22 x 2
23	-----	-	-	
24	051 228 00	2	2	
25	400 284 00	2	2	VM 8            DIN 980 - 8 C3A
26	-----	-	-	
27	-----	-	-	
29	051 890 00	1	1	
31	050 855 00	1	1	1,4 x 2 x 16
32	051 077 00	2	-	
33	016 352 10	1	1	W2

1(2-12,18-20,26,27,29,46-48,55)  
 62(2-12,18-20,26,27,29,55,63)

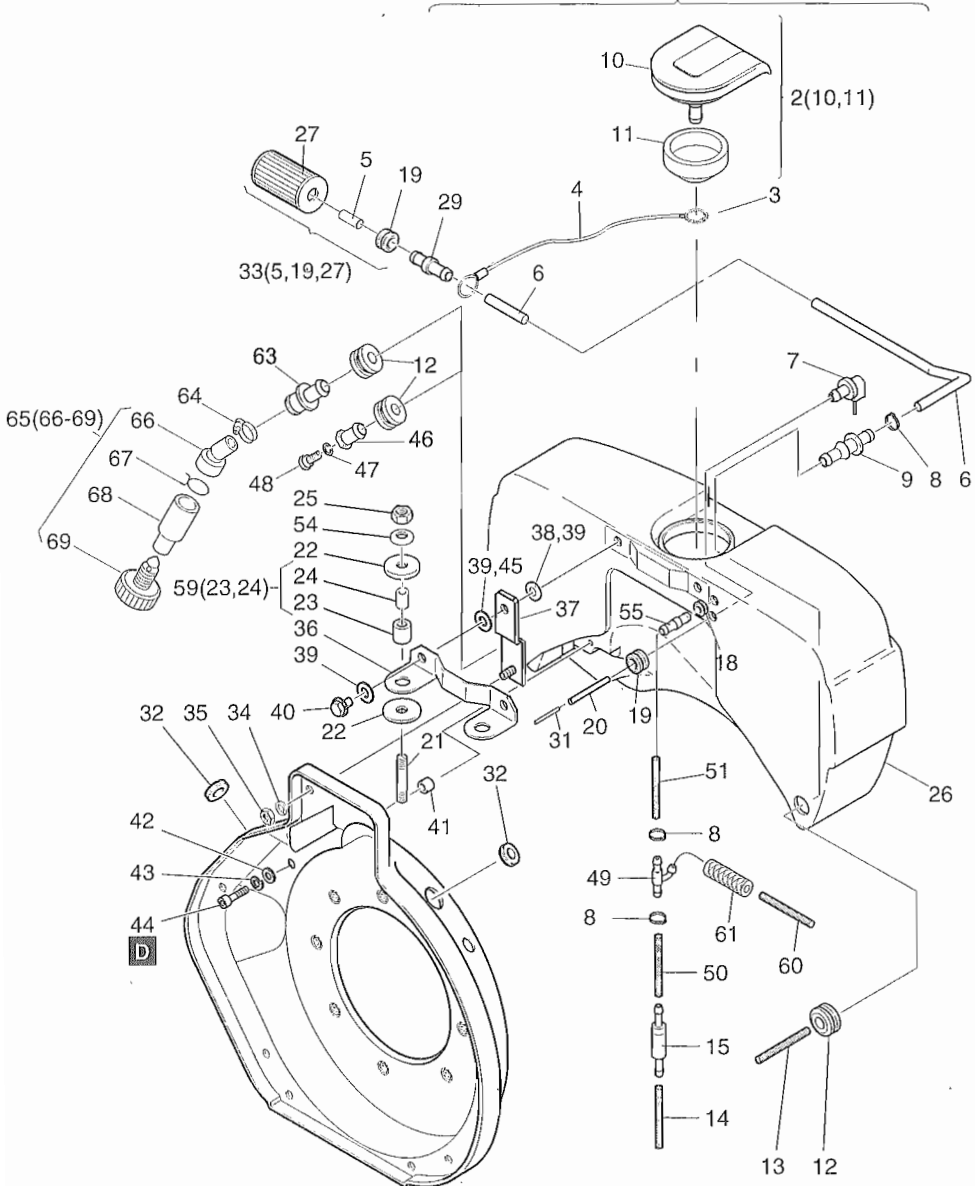

Fig.-No.	HATZ Ident-No.	Stück Qty.	P / W d / D	Bemerkungen Notes
		1B20	1B30	
33	016 353 10	1	1	RME
34	501 709 00	2	2	6 DIN 128 A3C
35	501 444 00	2	2	M 6 DIN 934 - 8 A3C
36	051 085 11	1	-	
36	051 223 00	-	1	
37	013 313 00	2	2	
38	501 200 00	2	-	A 6,4 DIN 9021 St A3C
39	051 100 10	4	4	7,1 x 17,9 x 2
40	015 570 00	2	-	6 x 18
40	016 771 00	-	2	M 6 x 20
41	041 188 00	2	4	6,5 x 13 x 4,8
42	501 445 00	2	4	6,4 DIN 125 St A3C
43	501 709 00	2	4	6 DIN 128 A3C
44	501 707 00	2	4	M 6 x 16 DIN 912 - 8.8 A3C
45	501 143 00	-	2	6,4 x 17 x 3DIN 7349 A3C
46	051 882 00	1	1	
47	503 131 00	1	1	A 6 x 10 DIN 7603-Cu.
48	036 136 00	1	1	M 6 A3C
49	051 756 01	1	1	
50	051 888 00	1	-	4,5 x 120
50	038 071 00	-	1	4,5 x 150
51	051 368 00	1	1	4,5 x 90
51	051 904 00	1	1	4,5 x 90 RME
54	501 481 00	2	2	8,4 DIN 125 St A3C
55	051 844 00	1	1	
59	016 558 00	2	2	
60	052 150 00	1	1	2,5 x 195
60	052 187 00	1	1	2,5 x 195 RME
61	052 130 00	1	1	7 x 25
62	016 502 10	1	-	3 l für Wasserabscheider
62	016 667 10	-	1	5 l für Wasserabscheider
63	051 723 00	1	1	
64	504 480 00	1	1	
65	015 194 01	1	1	
66	050 440 01	1	1	
67	050 369 00	1	1	
68	050 439 00	1	1	
69	504 148 00	1	1	

Kraftstoffbehälter m. externem Filter und Wasserabscheider  
 Fuel tank w. external filter and water separator  
 Reservoir à carburant avec filtre externe et décanteur d'eau  
 Depósito combustible con filtro externo y separador de agua  
 Serbatoio con filtro esterno e separ. d'acqua

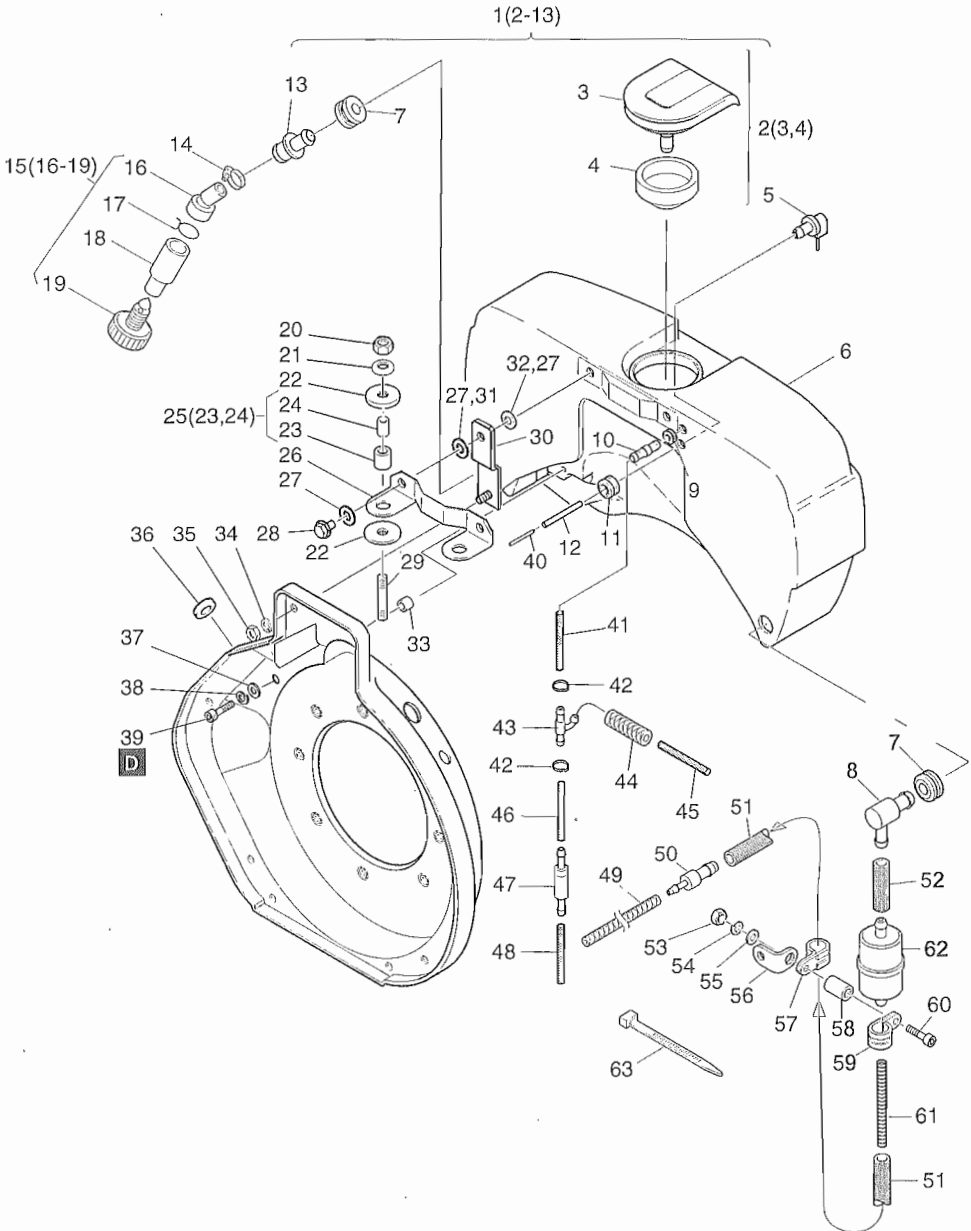

Fig.-No.	HATZ Ident-No.	Stück Qty.	P / W d / D	Bemerkungen Notes
		1B20	1B30	
1	017 031 00	1	-	3 l
1	017 032 00	-	1	5 l
2	015 353 02	1	1	
3	-----	-	-	
4	050 864 01	1	1	
5	015 349 00	1	1	
6	-----	-	-	
7	504 408 00	2	2	
8	016 840 10	1	1	
9	051 304 00	1	1	
10	051 844 00	1	1	
11	504 409 01	1	1	
12	050 856 00	1	1	
13	051 723 00	1	1	
14	504 480 00	1	1	
15	015 194 01	1	1	
16	050 440 01	1	1	
17	050 369 00	1	1	
18	050 439 00	1	1	
19	504 148 00	1	1	
20	400 284 00	2	2	VM8      DIN 980-8C3A
21	501 481 00	2	2	8,4      DIN 125 St A3C
22	051 098 10	4	4	8,2 x 22 x 2
23	-----	-	-	
24	051 228 00	2	2	
25	016 558 00	2	2	
26	051 085 11	1	-	
26	051 223 00	-	1	
27	051 100 10	4	4	7,1 x 17,9 x 2
28	015 570 00	2	-	M 6 x 18
28	016 771 00	-	2	M 6 x 20
29	502 319 00	2	2	M 8 x 25    DIN 835-8.8 A3C
30	013 313 00	2	2	
31	501 143 00	-	2	6,4 x 17 x 3DIN 7349 A3C
32	501 200 00	2	-	A 6,4      DIN 9021 St A3C
33	041 188 00	2	4	6,5 x 13 x 4,8
34	501 709 00	2	2	6          DIN 128 A3C
35	501 444 00	2	2	M 6          DIN 34-8A3C
36	051 077 00	2	-	





Fig.-No.	HATZ Ident-No.	Stück Qty.	P / W d / D	Bemerkungen Notes
		1B20	1B30	
37	501 445 00	2	4	6,4      DIN 125 StA3C
38	501 709 00	2	4	6          DIN 128A3C
39	501 707 00	2	4	M 6 x 16    DIN 912-8.8A3C
40	050 855 00	1	1	2 x 0,3 x 16
41	051 368 00	1	1	4,5 x 90
42	503 998 01	2	2	11,3
43	051 756 01	1	1	
44	052 130 00	1	1	7 x 25
45	052 150 00	1	1	2,5 x 195
46	051 888 00	1	-	4,5 x 120
46	038 071 00	-	1	4,5 x 150
47	008 055 01	1	1	
48	051 232 00	1	1	3,5 x 40
49	039 621 00	1	-	3,5 x 160
49	051 883 00	-	1	3,5 x 170
50	505 033 00	1	1	
51	038 051 00	1	-	7 x 250
51	034 932 00	-	1	7 x 280
52	052 067 00	1	1	7 x 40
53	501 444 00	1	1	M6          DIN 934-8 A3C
54	501 709 00	1	1	6          DIN 128A3C
55	501 445 00	1	1	6,4          DIN 125-St A3C
56	035 439 00	1	1	
57	501 735 00	1	1	10 / 15
58	041 390 00	1	1	6,5 x 12 x 18
59	501 584 00	1	1	14 / 15
60	501 82700	1	1	M 6 x 40    DIN 912-8.8 A3C
61	032 106 01	1	1	
62	504 788 00	1	1	Filter
63	503 584 00	2	2	

# A 02

Luftfilter  
Air filter  
Filtre à air  
Filtro de aire  
Filtro aria

Tafel Nr.  
Tabl. No.  
Tavola N.

18

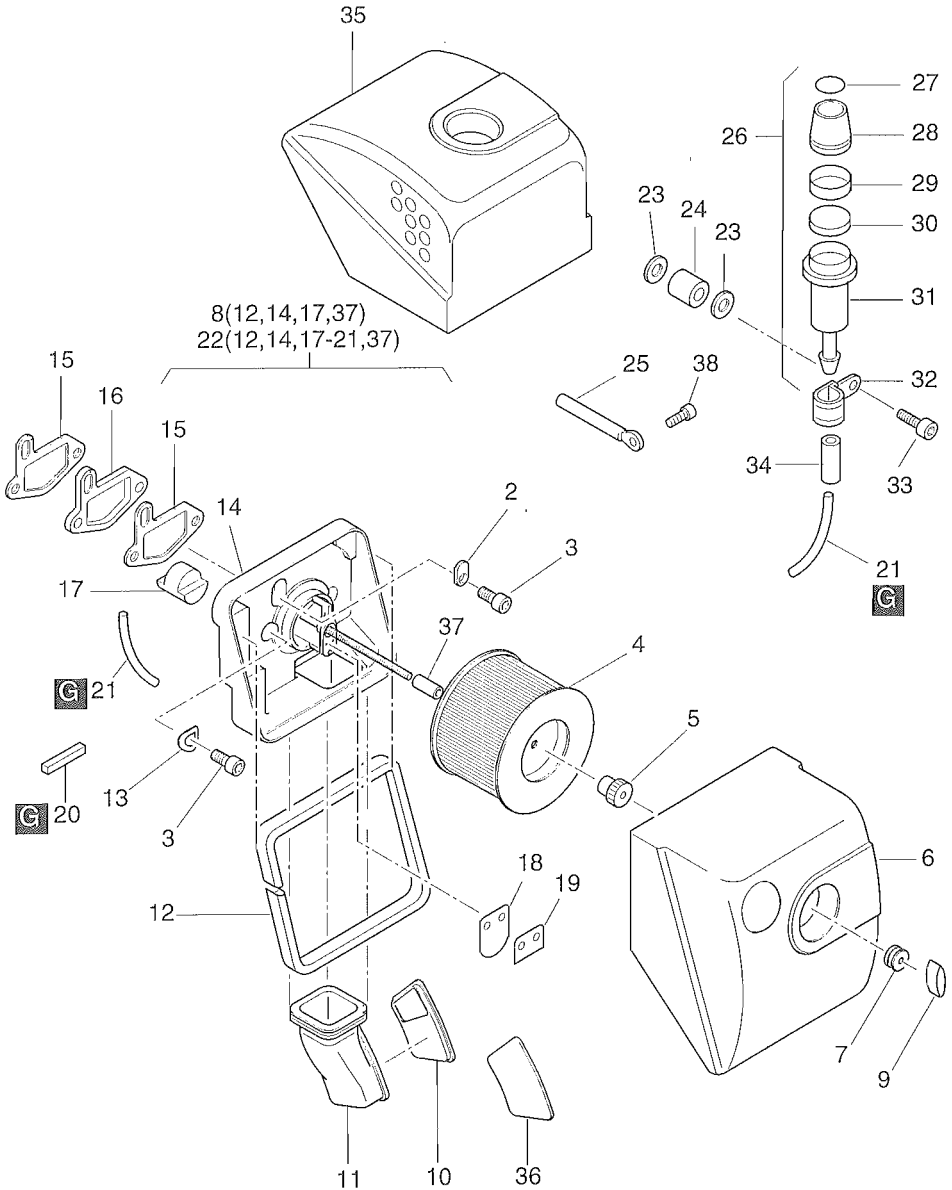

Fig.-No.	HATZ Ident-No.	Stück Qty.		P / W d / D	Bemerkungen Notes
		1B 20	1B 30		
2	050 564 00	1	1		
3	501 715 00	3	3		M8 x 25    DIN 912 - 8.8 A3C
4	504 260 00	1	1	W2	
5	504 543 00	1	1		
6	016 991 00	1	-		
6	016 993 00	-	1		
7	504 358 00	1	1		
8	016 079 01	1	1		
9	504 522 00	1	1		
10	041 042 00	1	-		
10	041 166 00	-	1		
11	041 030 00	1	-		
11	041 165 01	-	1		
12	052 161 00	1	1		545 mm
13	500 951 00	2	2		A 8            DIN 137-A3C
14	-----	-	-		
15	050 563 00	2	2	d2	
16	050 883 00	1	1		
17	050 981 00	1	1		
18	051 471 00	1	1		(schwarz, black, noir)
19	051 472 00	1	1		(rot, red, rouge)
20	051 750 00	1	1		14 x 9 x 30
21	050 446 10	1	1		2 x 4 x 135
22	016 036 00	1	-		
22	016 688 00	-	1		
23	503 805 00	2	2		J 6,4            DIN 6797-A3C
24	041 390 00	1	1		6,5 x 12 x 18
25	050 012 00	1	1		
26	014 998 01	1	1		(Pos. 27-31)
27	050 445 01	1	1		
28	050 436 01	1	1		
29	050 456 00	1	1		(grün, green, vert, verde)
30	051 372 00	1	1		Filter, Filtre, Filtro
31	050 437 00	1	1		

# A 02

Luftfilter  
Air filter  
Filtre à air  
Filtro de aire  
Filtro aria

Tafel Nr.  
Tabl. No.  
Tavola N.

## 18

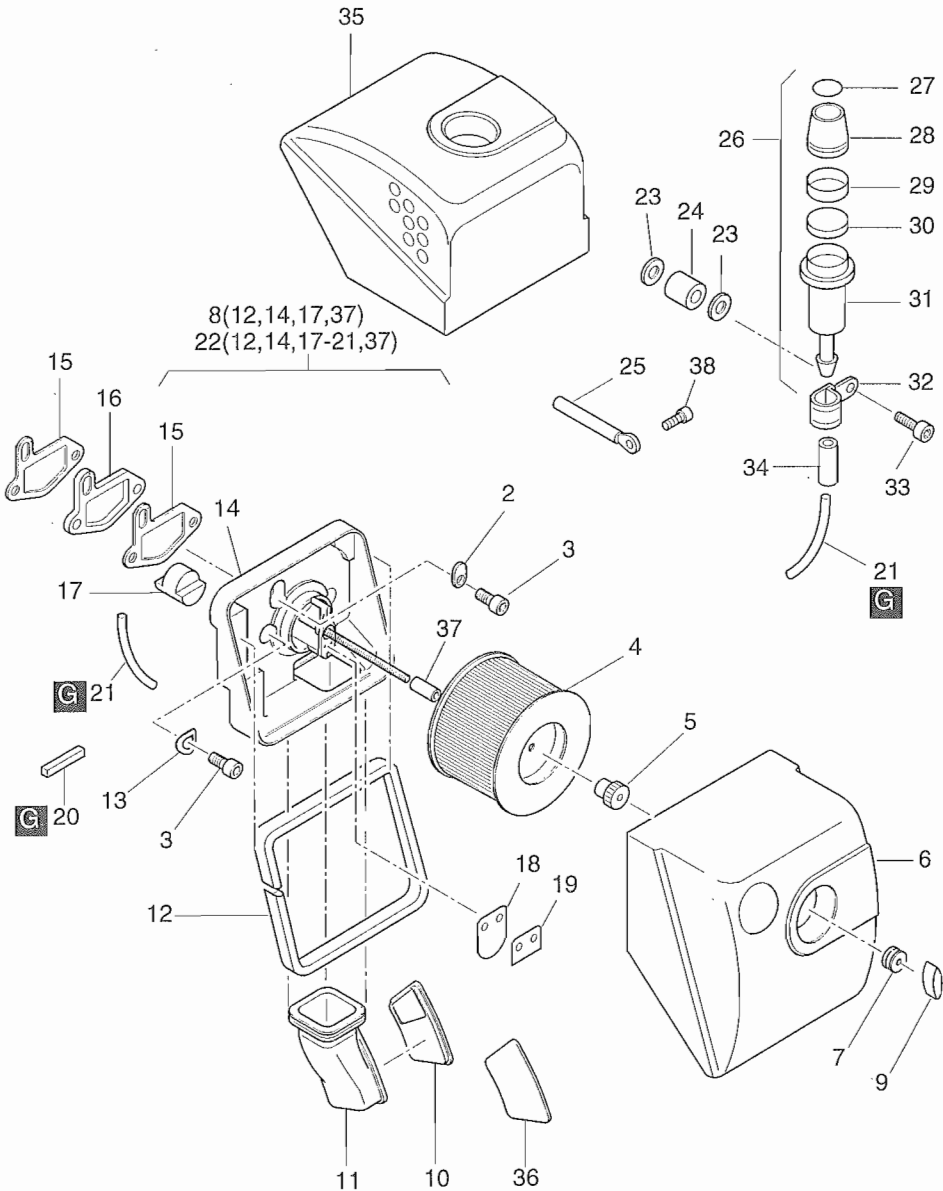

Fig.-No.	HATZ Ident-No.	Stück Qty.	P / W d / D	Bemerkungen Notes
		1B20	1B30	
32	501 735 00	1	1	10/15
33	503 749 00	1	1	M 6 x 35 DIN 912 - 8.8 A3C
34	039 177 00	1	-	3,5 x 140
34	051 883 00	-	1	3,5 x 170
35	016 992 00	1	-	
35	016 994 00	-	1	
36	041 138 00	1	-	
36	041 167 00	-	1	
37	051 662 00	1	1	32 mm
38	501 491 00	1	1	M 6 x 12 DIN 912-8.8A3C

A 03

Abgasdämpfer - 1B20  
Exhaust silencer - 1B20  
Silencieux - 1B20  
Silenciador - 1B20  
Marmitta - 1B20

Tafel Nr.  
Tabl. No.  
Tavola N.

19

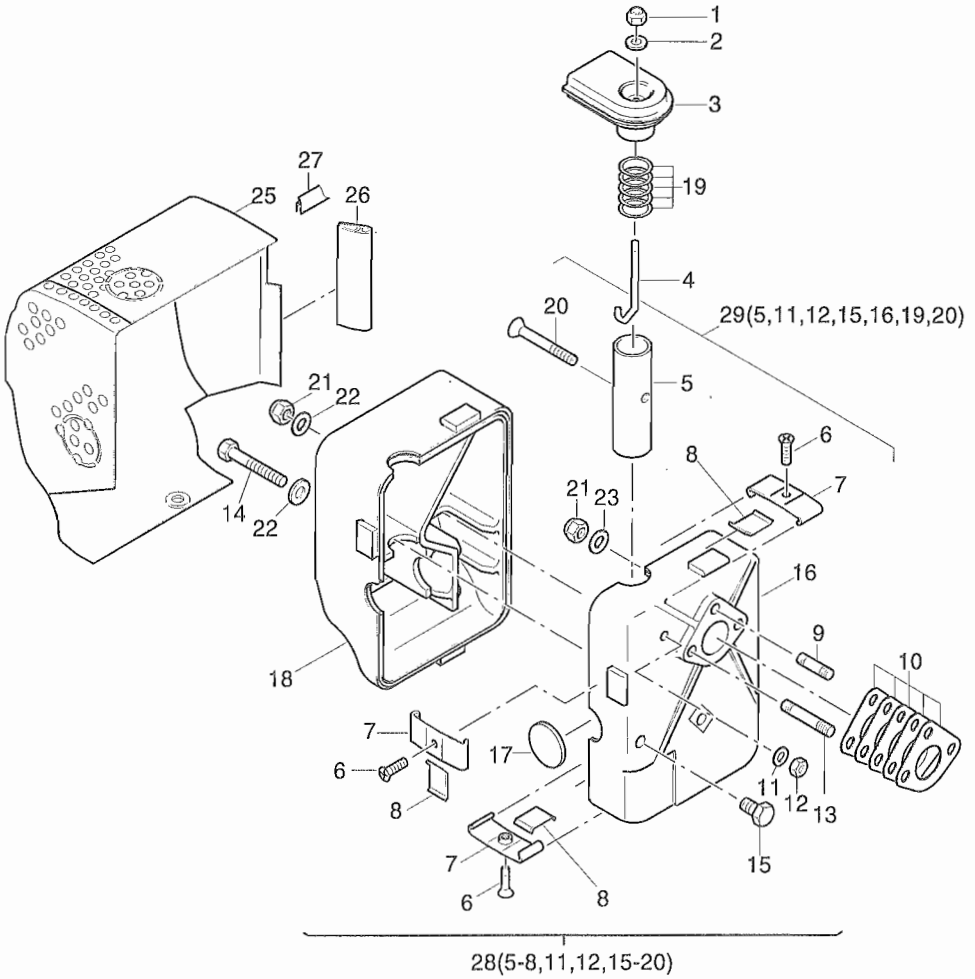

Fig.-No.	HATZ Ident-No.	Stück Qty.	P / W d / D	Bemerkungen Notes
1B20				
1	400 283 00	1		M6 SSN 440 - 8 - C3P
2	501 445 00	1		6,4          DIN 125 - St A3C
3	015 313 12	1		
4	050 811 01	1		M6
5	050 814 10	1		
6	504 225 00	3		M6 x 12    DIN 7991 - 8.8 A3C
7	015 312 01	3		
8	050 816 11	3		
9	501 281 00	2		M 8 x 30    DIN 835 - 10.9 A3C
10	050 801 00	5	d5	
11	501 445 00	1		6,4          DIN 125 - St A3C
12	400 283 00	1		M 6          SSN 440-8 C3P
13	500 395 00	1		M 8 x 110    DIN 835 - 8.8 A3C
14	500 288 00	1		M 8 x 90     DIN 931 - 8.8 A3C
15	504 505 00	1		M 8 x 12     DIN 7500 - D A3A
16	-----	-		
17	050 810 02	1		
18	-----	-		
19	051 270 00	5		28,1 x 34 x 0,5
20	504 450 00	1		M 6 x 35     DIN 7881 - 8.8 A3C
21	400 284 00	3		DIN 980-8 C3A
22	501 481 00	2		8,4          DIN 125-St. A3C
23	040 543 00	2		8,4 x 21 x 3
24	-----	-		
25	015 323 01	1		
26	051 003 00	1		65 mm
27	051 350 00	1		33 mm
28	015 311 05	1		
29	015 977 00	1		



A 03

Abgasdämpfer - 1B30  
Exhaust silencer - 1B30  
Silencieux - 1B30  
Silenciador - 1B30  
Marmitta - 1B30

Tafel Nr.  
Tabl. No.  
Tavola N.

20

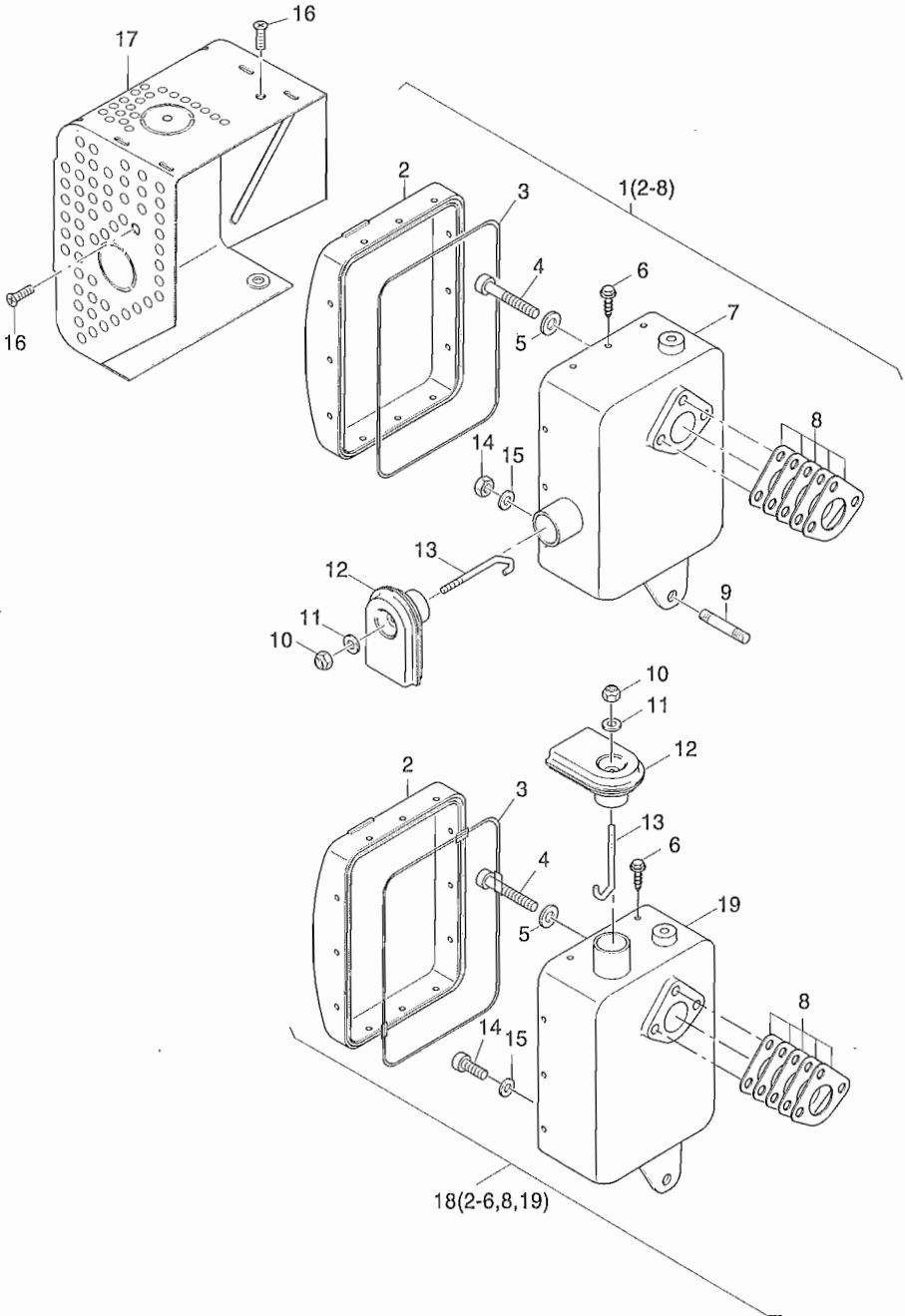

Fig.-No.	HATZ Ident-No.	Stück Qty.	P / W d / D	Bemerkungen Notes
		1B30		
1	016 858 00	1		
2	-----	-		
3	051 997 00	1		650 mm
4	504 040 00	3		M 8 x 30 DIN 912-8.8 C4P
5	040 543 00	3		8,4 x 21 x 3
6	504 872 00	12		4,8 x 13
7	-----	-		
8	051 036 00	5	d5	
9	505 041 00	1		M 6 x 16 DIN 835-8.8 A3C
10	400 283 00	1		M 6 SSN 440-8 C3P
11	501 445 00	1		6,4 DIN 125-St A3C
12	015 313 12	1		
13	050 811 01	1		M 6
14	400 283 00	1		M 6 SSN 440-8 C3P
15	501 143 00	1		6,4 DIN 7349 A3C
16	504 225 00	2		M 6 x 12 DIN 7991 A3C
17	016 457 01	1		
18	017 126 00	1		
19	-----	-		

# A 05

Starter, Generator  
Starter, alternator  
Démarreur, alternateur  
Arrancador, alternador  
Motorino avviamento, alternatore

Tafel Nr.  
Tabl. No.  
Tavola N.

21

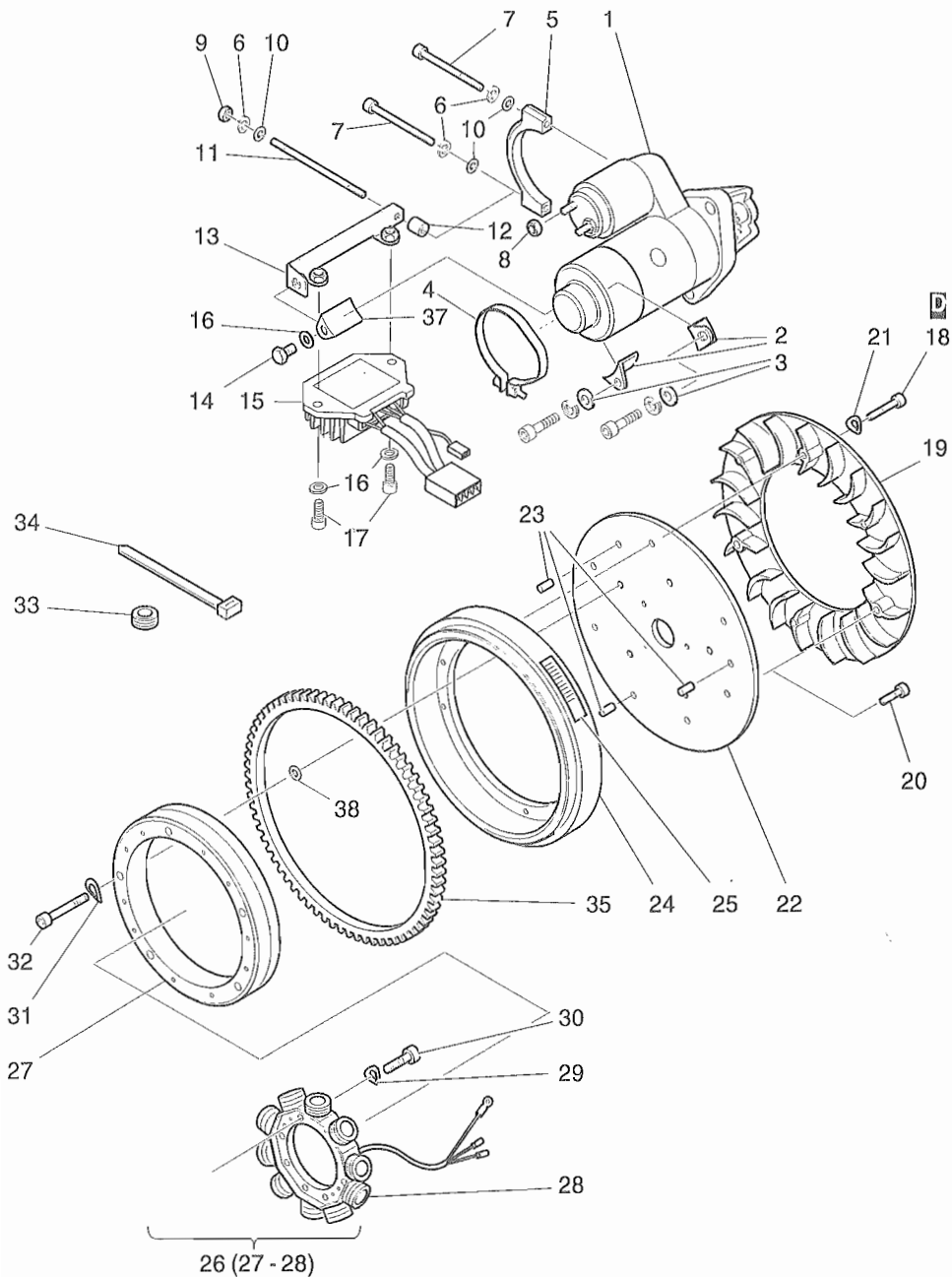

Fig.-No.	HATZ Ident-No.	Stück Qty.	P / W d / D	Bemerkungen Notes
		1B20	1B30	
1	017 234 00	1	1	12 V - 1,0 kW
1	504 833 00	1	1	24 V - 1,6 kW
2	041 384 00	2	2	
3	501 481 00	2	2	8,4          DIN 125 - St A3C
4	041 156 00	1	1	
5	040 991 00	1	1	
6	501 709 00	2	2	6          DIN 128 - A3C
7	504 443 00	2	2	M 6 x 80    DIN 912 - 8.8 A3C
8	500 232 00	1	1	BM8        DIN 439 - 5 A3C
9	501 444 00	1	1	M 6        DIN 934 - 8 A3C
10	501 445 00	2	2	6,4        DIN 125 - St A3C
11	504 559 00	1	1	MFS 6 x 90 DIN 949 - 1 8.8 A3C
12	036 714 00	1	1	7 x 12 x 15
13	015 609 00	1	1	
14	500 962 00	1	1	M 8 x 12    DIN 933 - 8.8 A3C
15	051 007 01	1	1	12 V
15	014 250 23	1	1	24 V
16	501 481 00	3	3	8,4          DIN 125 - St A3C
17	501 654 00	2	2	M 8 x 16    DIN 912 - 8.8 A3C
18	503 273 00	6	6	M 4 x 20    DIN 912 - 8.8 A3C
19	041 937 00	1	-	
19	041 936 00	-	1	
20	504 168 00	3	3	M 6 x 16    DIN 912 - 8.8 A3C Tuf.
21	500 034 00	6	6	A4          DIN137 - St
22	040 987 20	1	1	
23	500 352 00	3	3	6 x 12        DIN 1481 55 Si 7
24	040 982 30	1	-	
24	041 101 20	-	1	
25	041 172 00	1	-	„E-Start“ OT
25	041 174 00	-	1	„E-Start“ OT
26	504 359 01	1	1	12 V
26	015 800 00	1	1	24 V        o. BATT.
27	-----	-	-	
28	-----	-	-	
29	500 819 00	4	4	A 5        DIN 137 A3C
30	504 271 00	4	4	M 5 x 25    DIN 912 - 8.8 A3C
31	500 812 00	5	5	A 6        DIN 137 A3C
32	504 487 00	5	5	M 6 x 30    DIN 6912 - 8.8 A3C
33	035 654 00	1	-	
34	503 584 00	3	3	
35	040 986 00	1	-	
35	041 080 00	-	1	
37	041 384 00	1	1	
38	501 143 00	5	5	6,4          DIN 7349 - A3C

A 05  
A 10

Armaturen, Leitungen  
Electric equipment, wirings  
Équipement électrique, cable  
Equipo eléctrico, cables  
Equipaggiamento elettrico, cablaggio

Tafel Nr.  
Tabl. No.  
Tavola N.

22

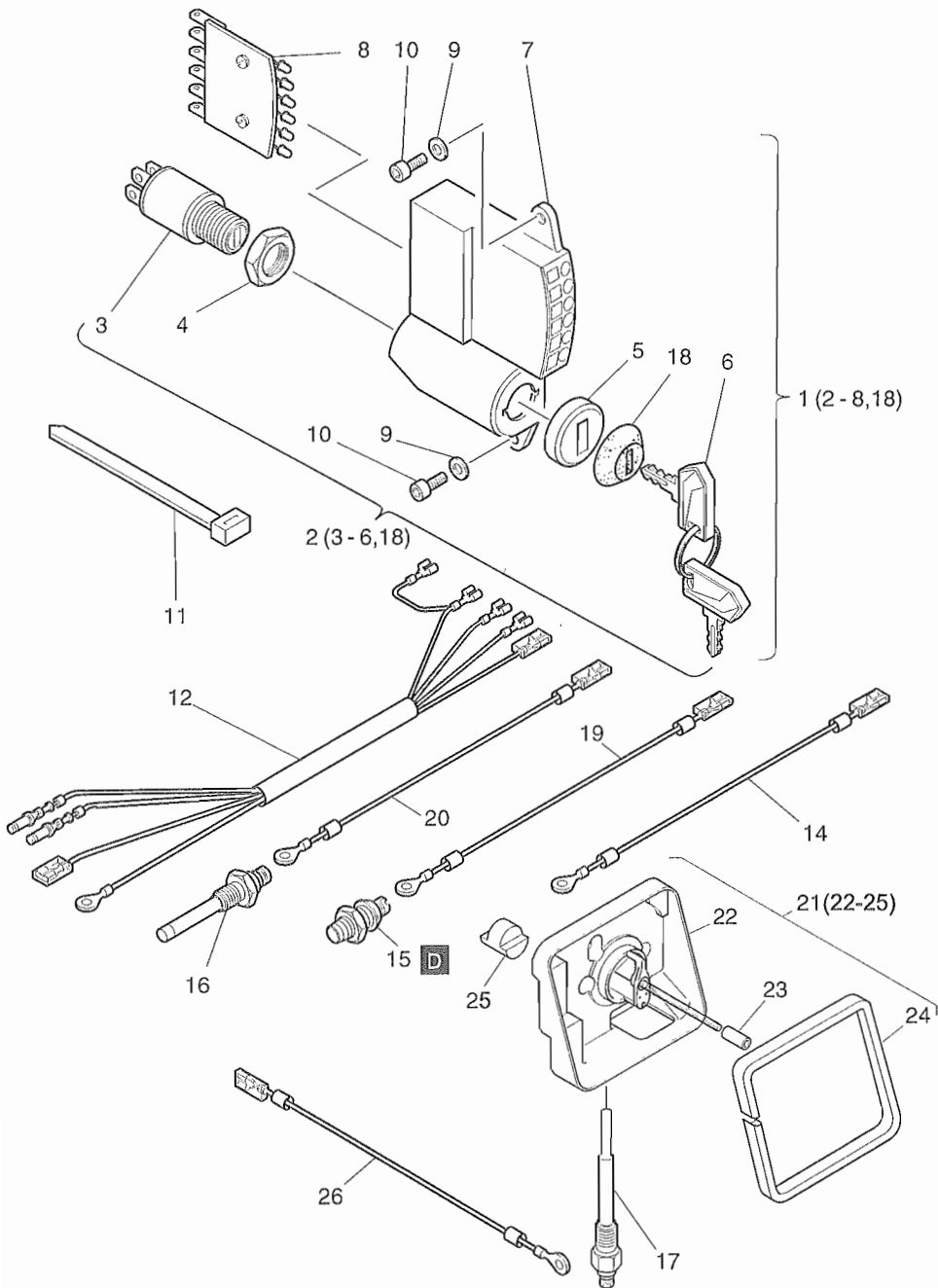

Fig.-No.	HATZ Ident.-No.	Stück Qty.	P / W d / D	Bemerkungen Notes
		1B20	1B30	
1	015 608 01	1	1	
2	503 844 01	1	1	
3	-----	-	-	
4	-----	-	-	
5	-----	-	-	
6	504 049 00	1	1	
7	-----	-	-	
8	-----	-	-	
9	501 445 00	2	2	6,4      DIN 125 St A3C
10	501 491 00	2	2	M 6 x 12    DIN 912 - 8.8 A3C
11	503 584 00	2	2	
12	015 421 01	1	1	
14	015 468 00	1	1	(0)
15	400 213 00	1	-	Oil
15	504 691 00	-	1	Oil
16	502 686 00	1	1	Temp.
17	504 492 00	1	1	12 V
18	051 264 02	1	1	
19	015 465 00	1	1	(4)
20	015 469 00	1	1	(5)
21	016 078 01	1	1	
22	-----	-	-	
23	051 662 00	1	1	32 mm
24	052 161 00	1	1	545 mm
25	050 981 00	1	1	
26	015 439 01	1	1	(6)

# A 09

Drehzahlverstellung  
Speed control  
Reglage régime  
Ajuste de revoluciones  
Comando acceleratore

Tafel Nr.  
Tabl. No.  
Tavola N.

23

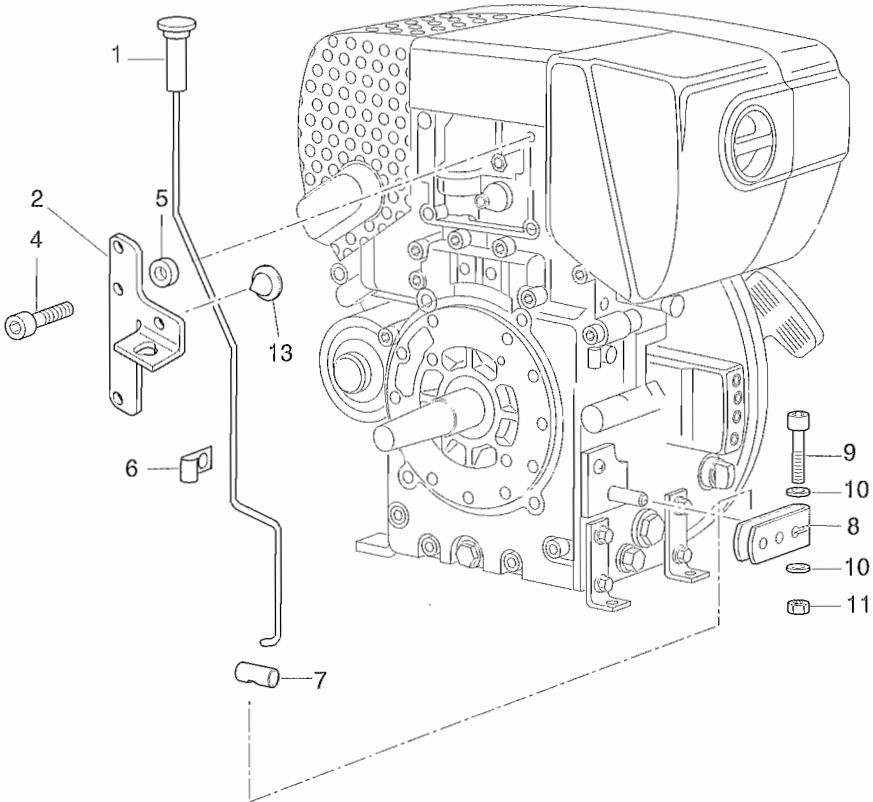
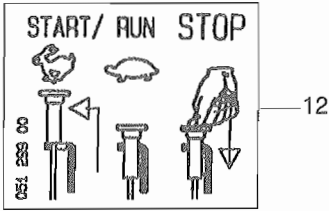

Fig.-No.	HATZ Ident-No.	Stück Qty.	P / W d / D	Bemerkungen Notes
		1B20	1B30	
1	015 751 21	1	1	
2	051 411 02	1	1	
3	-----	-	-	
4	504 629 00	2	2	M 6 x 20 DIN 6912 - 8.8 A3C
5	033 546 00	2	2	7 x 12 x 8
6	051 246 00	1	1	
7	051 185 00	1	1	
8	051 177 00	1	1	
9	504 271 00	1	1	M 5 x 25DIN 912 - 8.8 A3C
10	502 163 00	2	2	5,3 DIN 125-StA3C
11	500 943 00	1	1	M5 DIN 934-8 A3C
12	051 299 00	1	1	
13	504 829 00	1	1	



**A 09**

Drehzahlverstellung für Bowdenzug  
Speed control for Bowden-cable  
Réglage régime pour câble bowden  
Ajuste de revolutiones para cable bowden  
Comando acceleratore per bowden

Tafel Nr.  
Tabl. No.  
Tavola N.

**24**

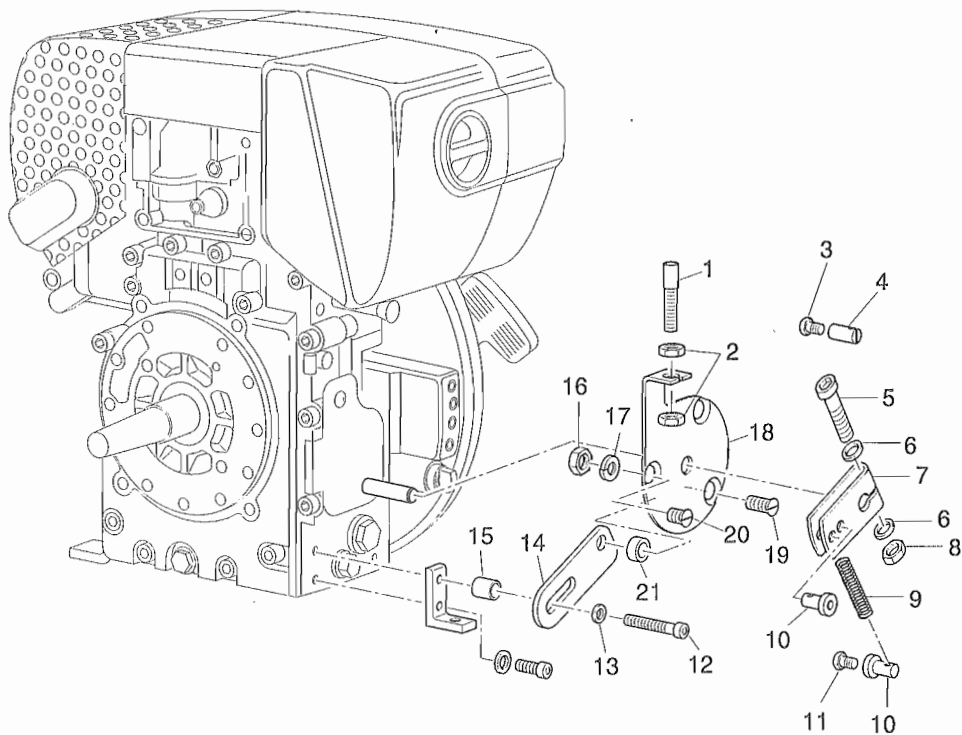

Fig.-No.	HATZ Ident-No.	Stück Qty.	P / W d / D	Bemerkungen Notes
		1B20	1B30	
1	051 412 00	1	1	M 6
2	501 444 00	2	2	M 6        DIN 934-8    A3C
3	500 250 00	1	1	M 4 x 10    DIN 933-8.8    A3C
4	504 830 00	1	1	2,2        NR. 1120
5	504 271 00	1	1	M 5 x 25    DIN 912-8.8    A3C
6	502 163 00	2	2	5,3        DIN 125-St    A3C
7	051 177 00	1	1	
8	500 943 00	1	1	M 5        DIN 934-8    A3C
9	504 846 00	1	1	VD-179 E
10	504 831 00	2	2	2,2        NR. 1450
11	500 250 00	1	1	M 4 x 10    DIN 933-8.8    A3C
12	502 488 00	1	1	M 8 x 60    DIN 6912-8.8    A3C
13	501 481 00	1	1	8,4        DIN 125-St    A3C
14	051 175 00	1	1	
15	035 206 00	1	1	9 x 14 x 20
16	503 283 00	1	1	VM 6        DIN 980-8    A3C
17	502 085 00	1	1	8            DIN 128        A3C
18	051 176 00	1	1	
19	504 239 00	1	1	M 6 x 20    DIN 7991-10.9    A3C
20	503 808 00	1	1	M 6 x 16    DIN 7991-8.8
21	032 929 00	1	1	8,2 x 11 x 12

Anbauteile Hydraulikpumpe  
Mount. parts hydr. pump  
Pièces mont.-pompe hydr.  
Piezas mont. bomba hidr.  
Particorari per montaggio pompa idraulica

Tafel Nr.  
Tabl. No.  
Tavola N.

25

A 18

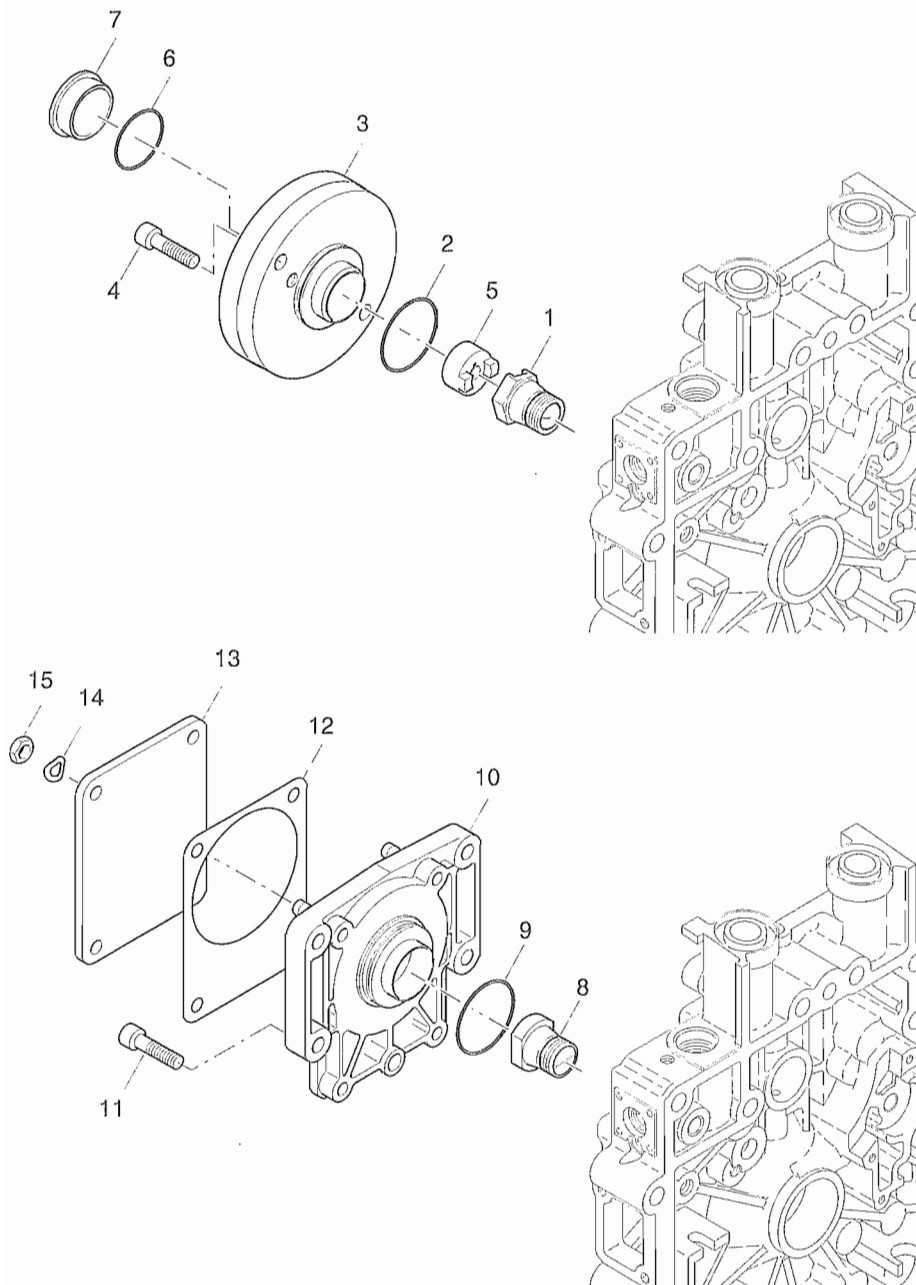

Fig.-No.	HATZ Ident-No.	Stück Qty.	P / W d / D	Bemerkungen Notes
		1B20-X	1B30-X	
1	015 581 00	1	1	
2	504 545 00	1	1	44 x 1,5
3	051 150 00	1	1	
4	501 759 00	2	2	M 8 x 30 DIN 912-8.8 A3C
5	051 147 00	1	1	
6	502 882 00	1	1	32 x 2,5
7	501 631 01	1	1	F 25 Ø 38,8
8	015 580 00	1	1	
9	504 545 00	1	1	44 x 1,5
10	016 648 00	1	1	
11	504 943 00	4	4	M 8 x 20 DIN 912-8.8 Tuf.
12	035 680 00	1	1	
13	037 616 00	1	1	
14	500 951 00	4	4	A 8 DIN 137 A3C
15	501 480 00	4	4	

**A 90**

Motorausrüstung EPA  
Spec. equipment EPA  
Equipm. spec. EPA  
Equipo espec. EPA  
Kit trasformazione EPA

Tafel Nr.  
Tabl. No.  
Tavola N.

**26**

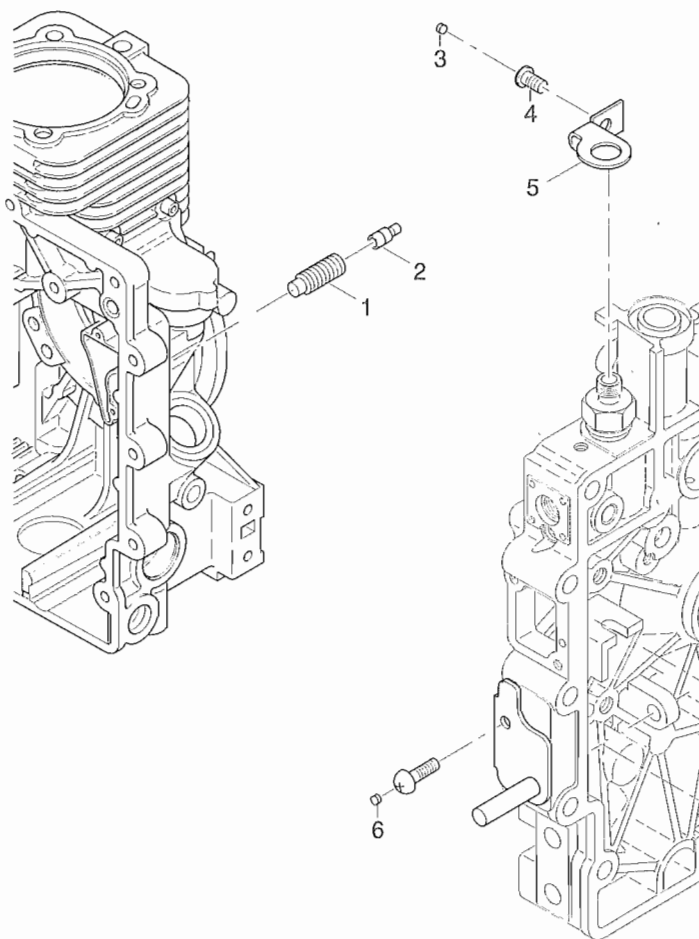

Fig.-No.	HATZ Ident-No.	Stück Qty.	P / W d / D	Bemerkungen Notes
		1B20	1B30	
1	041 987 00	1	1	
2	041 505 00	1	1	
3	041 706 00	1	1	4,15
4	504 950 00	1	1	M 6 x 12 DIN 7380-10.9 A3C
5	041 853 00	1	1	
6	052 015 00	1	1	3

**Serien-Nr.-Änderungen**  
**Serial-code modification list**  
**Modification des Nos de serien**  
**Modificación de los Nos de serie**  
**Modifica dei codici**

**IMT.-No.**

---

1B20.10	1B20.11	97.566
1B20.11	1B20.12	97.567
1B20.12	1B20.13	97.568
1B20.13	1B20.14	97.569
1B20.14	1B20.15	98.573
1B20.15	1B20.16	98.574
1B20.16	1B20.17	98.575
1B20.17	1B20.18	98.576
1B20.18	1B20.19	98.577
1B20.19	1B20.20	98.580
1B20.20	1B20.21	99.588
1B20.21	1B20.22	00.590
1B20.22	1B20.23	00.594
1B20.23	1B20.24	00.598
1B20.24	1B20.25	00.601
1B20.25	1B20.26	01.613
1B30.10	1B30.11	98.573
1B30.11	1B30.12	98.575
1B30.12	1B30.13	98.576
1B30.13	1B30.14	98.577
1B30.14	1B30.15	98.580
1B30.15	1B30.16	99.585
1B30.16	1B30.17	99.586
1B30.17	1B30.18	99.589
1B30.18	1B30.19	00.598
1B30.19	1B30.20	00.606
1B30.20	1B30.21	00.607
1B30.21	1B30.22	01.613





