

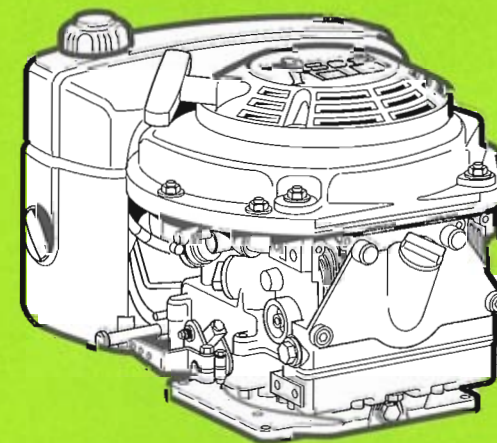

MOTORENFABRIK HATZ • D-94099 RUHSTORF • Germany
Tel.: 0 85 31 / 319-0 • Telefax: 0 85 31 / 31 94 18
eMail: marketing@hatz-diesel.de • <http://www.hatz-diesel.de>

Original-Ersatzteile
Original-spare parts
Pièces de rechange d'origine
Repuestos originales
Pezzi di ricambio originali

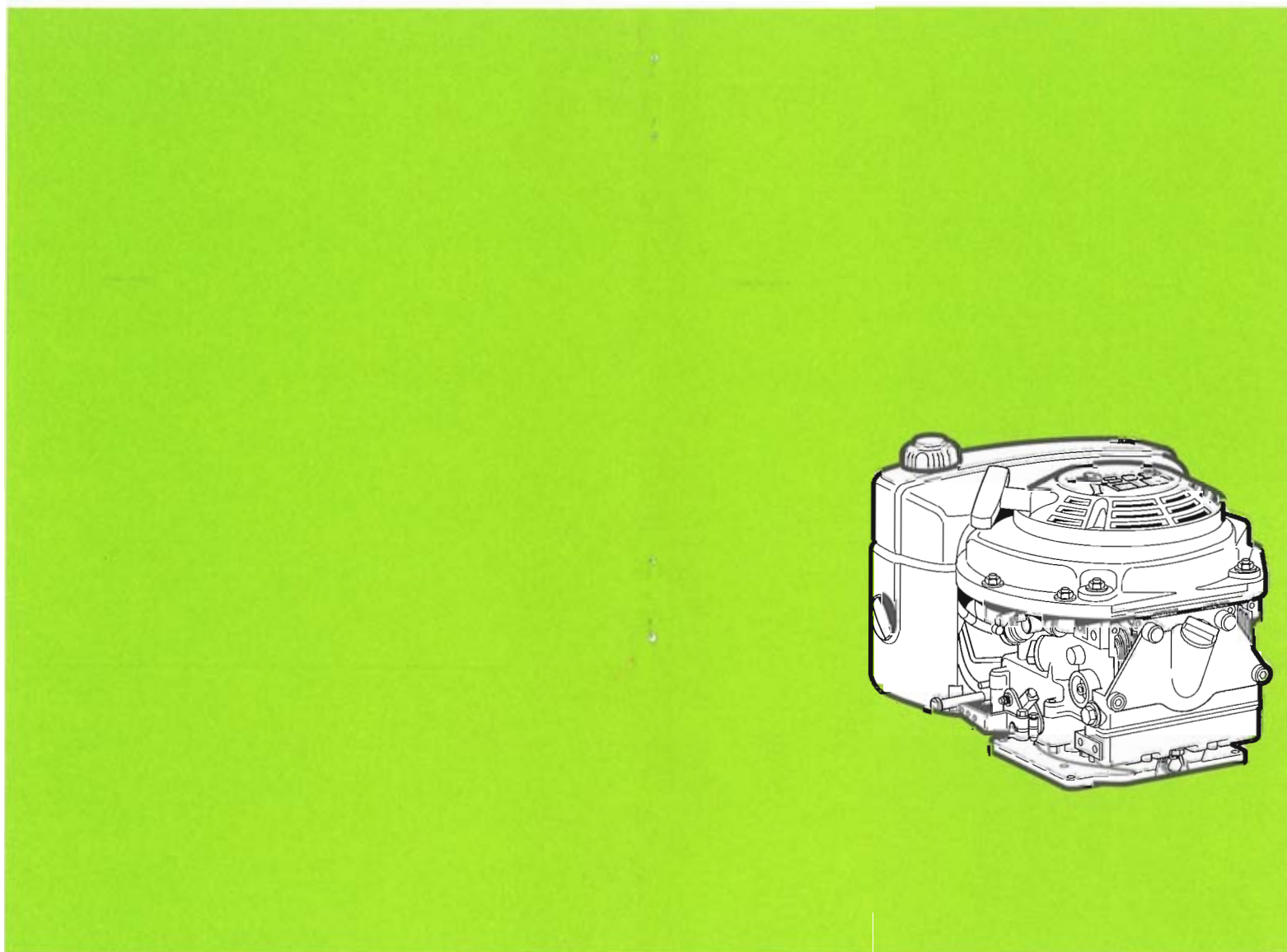

1B40V

434 840 71-10.01-0.1
Printed in Germany

Bestellung für HATZ-Original-Ersatzteile

Order for HATZ Original spare parts

Commande de pièces d'origine HATZ

Pedido de repuestos originales HATZ

Ordine parti di ricambio originali HATZ

1

Besteller / Customer / Client / Cliente / Cliente

2

TYP	KENNZ.	
MOTOR/FABRIK NO.		
MIN ⁻¹		

3

Ersatzteilliste Nr./ Spare parts list no./ Liste des pièces de rechange no./ Lista de repuestos No./ Lista ricambi n.

1 B 40V / W.11

4

Stück / Qty / Q.tà	HATZ Ident No.	Stück / Qty / Q.tà	HATZ Ident No.

5

Versandart / Mode of dispatch / Mode d'expédition / Despacho deseado / Modo di spedizione

Post / Surface / Poste / Correo / Posta Luffracht / airfreight / frêt aérien / flete aereo / Via aerea

Express / express / exprès / expreso / Espresso

6

Versandadresse / Consignee / Adresse destination / Dirección / Indirizzo di destinazione

Bestellung an: Order at: Commande à: Pedido a:

- die nächste HATZ-Servicestelle (siehe Servicestellenverzeichnis)
- your nearest HATZ service station (see service-list)
- votre station-service HATZ la plus proche (voir liste "Service")
- al servicio HATZ más cercano (ver cuaderno de Servicio)
- al più vicino centro di servizio HATZ (vedi lista centri autorizzati)

MOTORENFABRIK HATZ
D-94099 RUHSTORF

Tel: 0 85 31 / 319 - 0

Fax: 0 85 31 / 31 94 21

Inhaltsverzeichnis

Index

M ..	Grundmotor	Basic engine	
00	Ersatzteilsätze	Spare part kits	01
34	Zubehör	Accessories	02
01	Kurbelgehäuse	Crankcase	03
01	Massenausgleich	Compensation of masses	04
02	Kurbelwelle	Crankshaft	05
04	Nockenwelle	Camshaft	06
05, 06	Kolben, Pleuel, Zylinder	Piston, conrod, cylinder	07
07	Zylinderkopf	Cylinder head	08
10, 32	Ölpumpe, Regler	Oil pump, governor	
	Drehzahlverstellung	speed control	09
11	Steuerdeckel	Timing cover	10
13,17	Gebälse, Schwungrad	Blower, flywheel	11
14	Einspritzausrüstung	Injection equipment	12
15	Reversierstarter	Recoil starter	13
26	Luftführung	Air ducting	14,15
31	Kurbelgehäuseentlüftung	Crankcase breathing system	16
A ..	Zusatzausrüstung	Equipments	
01	Kraftstoffbehälter	Fuel tank	17
02	Luftfilter	Air filter	18
03	Abgasdämpfer	Exhaust silencer	19
05	Starter,Generator,	Starter, alternator,	20
05, 10	Armaturen, Leitungen	Electric equipment, wirings	21
09	Drehzahlverstellung-Bowdenzug	Speed control for Bowden-cable	22
18	Anbauteile-Hydraulikpumpe	Mount. parts hydr. pump	23
90	Motorausrüstung EPA	Spec. equipment EPA	24

	Sommaire:	Indice	
M ..	Moteur de base	Motor de base	
00	Jeu de pièces de rechange	Juegos de piezas de recambios	01
34	Accessoires	Accesorios	02
01	Carter moteur	Caja cigueñal	03
01	Equilibrage des masses	Compensación de las masas	04
02	Vilebrequin	Cigueñal	05
04	Arbre à cames	Arbol de levas	06
05, 06	Piston, bielle, cylindre	Embolo, biela, cilindro	07
07	Culasse	Culata	08
10, 32	Pompe à huile, regulateur regime, réglage regime	Bomba de aceite, regulador, ajuste de revoluciones	09
11	Couvercle distribution	Tapa de mando	10
13,17	Soufflerie, volant	Ventilador, volante	11
14	Equipment d'injection	Equipo de inyección	12
15	Demarreur reversible	Arrancador reversible	13
26	Carter ventilation	Conducción de aire	14,15
31	Reniflard	Purgador	16
A ..	Accessoires	Equipos	
01	Reservoir à carburant	Depósito combustible	17
02	Filtre à air	Filtro de aire	18
03	Silencieux	Silenciador	19
05	Demarreur, alternateur	Arrancador, alternador	20
05, 10	Equipement électrique, cable	Equipo eléctrico, cables	21
09	Reglage régime p. câble bowden	Ajuste de velocidad p. cable bowden	22
18	Pièces mont.-pompe hydr.	Piezas mont. bomba hidr.	23
90	Equip. spec. EPA	Equipo espec. EPA	24

Indice

Tavola N.

M ..**Motore de base**

00	Serie guarnizioni	01
34	Kit accessori	02
01	Basamento motore	03
01	Masse controrotanti	04
02	Albero a gomito	05
04	Albero a camme	06
05, 06	Pistone, biella, cilindro	07
07	Testa	08
10, 32	Pompa olio, regolatore di giri, Comando acceleratore	09
11	Coperchio distribuzione	10
13, 17	Ventilatore, volano	11
14	Equipaggiamento di iniezione	12
15	Avviamento a strappo	13
26	Carter ventilatore	14,15
31	Sfiato basamento	16

A ..**Accessori**

01	Serbatoio	17
02	Filtro aria	18
03	Scarico	19
05	Motorino avviamento, alternatore,	20
05, 10	Equipaggiam. elettrico, cablaggio	21
09	Comando acceleratore per bowden	22
18	Particorari per montaggio pompa idraulica	23
90	Kit trasformazione EPA	24

M 00 Ersatzteilsätze
Spare part kits
Jeux de pièces de rechange
Juegos de piezas de recambios
Serie guarnizioni

Tafel Nr.
Tabl. No.
Tavola N.

01

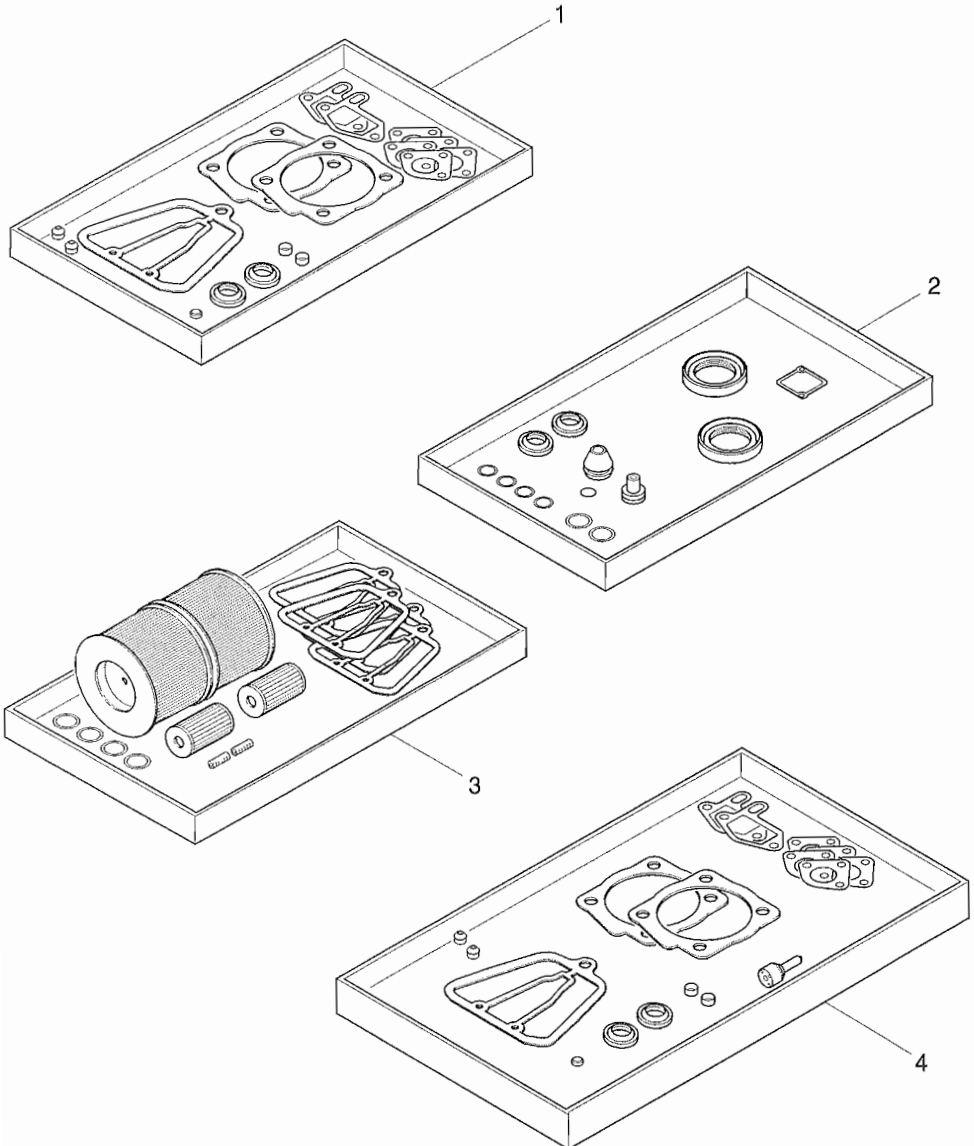

Fig.-No.	HATZ Ident-No.	Stück Qty.	P / W d / D	Bemerkungen Notes
1B40 V/W				
				<p>W: Im Wartungssatz enthalten. Incl. in maintenance kit. Contenu dans le jeu d'entretien. Incluido en el juego de mantenimiento. Contenuto nella serie manutenzione.</p> <p>d: Im Dichtungssatz f. 1 Zyl.-Kopf enthalten. Incl. in gasket set f. 1 cyl. head. Contenu dans le jeu de joint p. 1 culasse. Incluido en el juego de juntas p. 1 culata. Contenuto nella serie guarnizioni p. 1 testa.</p> <p>P: Im Pannensatz enthalten. Incl. in emergency kit. Contenu dans le jeu secour. Incluido en el juego para averias. Contenuto nella serie di prima necessità.</p> <p>D: Im Dichtungssatz Kurbelgeh. Incl. in gasket set crankcase. Contenu dans le jeu de joints carter moteur. Incluido en el juego de juntas caja cigueñal. Contenuto nella serie guarnizioni basamento.</p> <p>1: Anzahl pro Satz - Qty. per kit Quantite p. jeu - Cantidad p. juego. Quantità per serie</p>
1	016 792 00	1	P 1	Dichtungssatz für 1 Zylinderkopf Gasket set for 1 cyl. head Jeu de joint p. 1 culasse Juego de juntas para 1 culata Serie guarniziono per 1 testa
2	017 103 00	1		Dichtungssatz für Kurbelgehäuse Gasket set for crankcase Jeu de joints p. carter moteur Juego de juntas para caja cigueñal Serie guarnizioni basamento
3	017 104 00	1		Wartungssatz für 1000 h 1000 hours maintenance kit Kit d'entretien 1000 heures - Juego de piezas para servicio 1000 horas Kit di manutenzione a 1000 ore
4	016 795 00	1		Pannensatz - Emergency kit Kit de secours - Juego para averias Kit di prima necessità

Fig.-No.	HATZ Ident-No.	Stück Qty.	P / W d / D	Bemerkungen Notes
1B40 V/W				
1	013 297 00	1		Zubehörsatz - Accessoires kit Sort. accessoires Juego de accesorios Serie accessorie
2	051 632 01	1		160 x 67 mm
3	051 300 00	1		
4	051 301 00	1		

Dicht- und Klebstoffe
Sealing- and bonding adhesives
Etanchéifiant et Colle

Materias para empaquetar y pegar
Adesivi e collanti

A = 502 230 01	Loctite Activator N	500 ml	} siehe Hinweis auf den einzelnen Bildtafeln } as specified in the individual tables } suivant les remarques sur les tableau correspondant } según las indicaciones de las tablas correspondientes } seguire le indicazioni sul quadro corrispondente
B = 502 231 00	Loctite 573	50 ml	
C = 502 232 00	Loctite 601	50 ml	
D = 502 233 00	Loctite 221	50 ml	
E = 502 234 00	Loctite 648	10 ml	
F = 502 238 00	Technicoll 8058	0,75 kg	
+ 502 239 00	Technicoll 8367	0,75 kg	
G = 502 565 01	Loctite IS 407	20 g	
H = 502 825 01	Silicon	30 ml	
J = 502 830 03	Hochtemp. Paste	100 ml	
K = 503 426 00	Hochtemp. Fett	100 g	
L = 502 566 00	Silicon sealer	100 g	
M = 504 851 00	Schleifpaste	80 g	

M 01

Kurbelgehäuse
Crankcase
Carter moteur
Caja cigueñal
Basamento motore

Tafel Nr.
Tabl. No.
Tavola N.

03

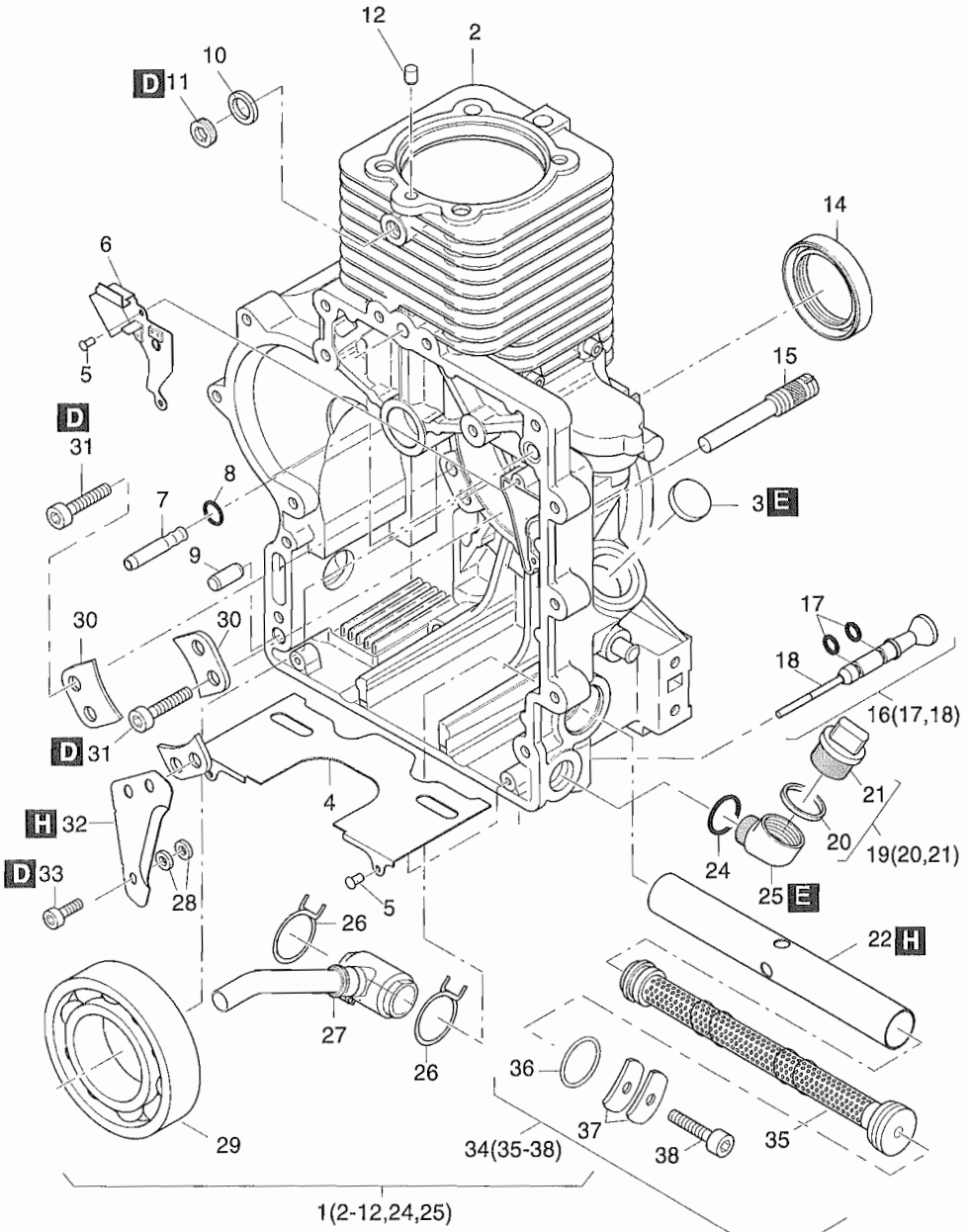

Fig.-No.	HATZ Ident-No.	Stück Qty.	P / W d / D	Bemerkungen Notes
1B40 V/W				
1	01704200	1		
2	-----	-		
3	-----	-		
4	04141600	1		
5	40002600	4		3,2
6	01336400	1		
7	05084300	1		
8	50440300	1	D1	8 x 1,5
9	50249101	1		8 M 6 x 20 DIN 6325 2-Fasen
10	50062400	1		A 10 x 13,5 DIN 7603 - Cu
11	50062300	1		M 10 x 1 DIN 908 - 5.8 A3C
12	-----	-		
14	50479000	1	D1	45 x 60 x 8
15	04144401	1		
16	01350500	1		
17	40022000	2	D2	5 x 2
18	-----	-		
19	01613100	1		
20	04125000	1	D1	26 x 35 x 3
21	-----	-		
22	04141500	1		
24	50475901	1	D1	20 x 4
25	-----	-		
26	05036900	2		
27	01364100	1		
28	50216300	2		5,3 DIN 125-St A3C
29	50478900	1		6310 C4 DIN 625
30	04133800	3		
31	50143200	6		M 6 x 18 DIN 6912 - 10.9
32	04199400	1		
33	50274500	1		M 5 x 12 DIN 912-8.8 A3C
34	01542702	1		
35	-----	-		
36	50475901	1	D1,W1	20 x 4
37	05148200	2		
38	50170700	1		M 6 x 16 DIN 912 - 8.8 A3C

M 01

Massenausgleich
Compensation of masses
Equilibrage des masses
Compensación de las masas
Masse controrotanti

Tafel Nr.
Tabl. No.
Tavola N.

04

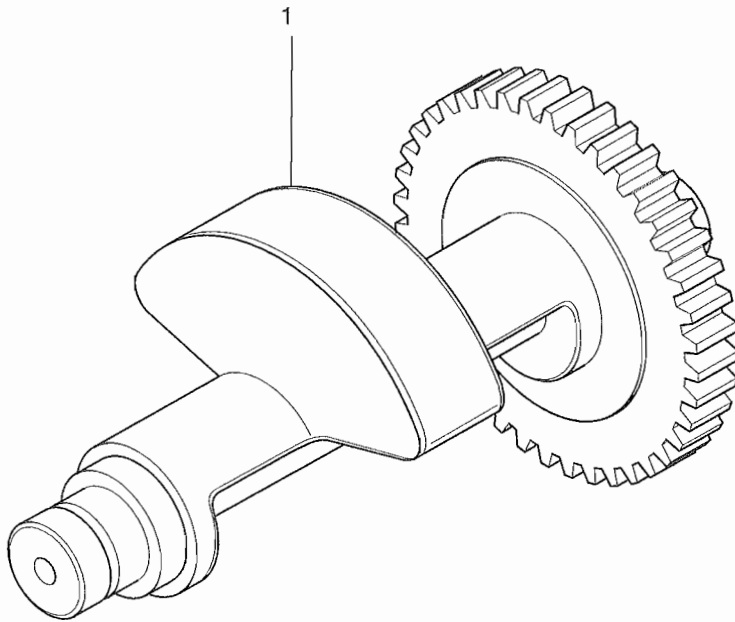

Fig.-No.	HATZ Ident-No.	Stück Qty.	P / W d / D	Bemerkungen Notes
		1B40 W		
1	01349201	1		

M 02

Kurbelwelle
Crankshaft
Vilebrequin
Cigueñal
Albero a gomito

Tafel Nr.
Tabl. No.
Tavola N.

05

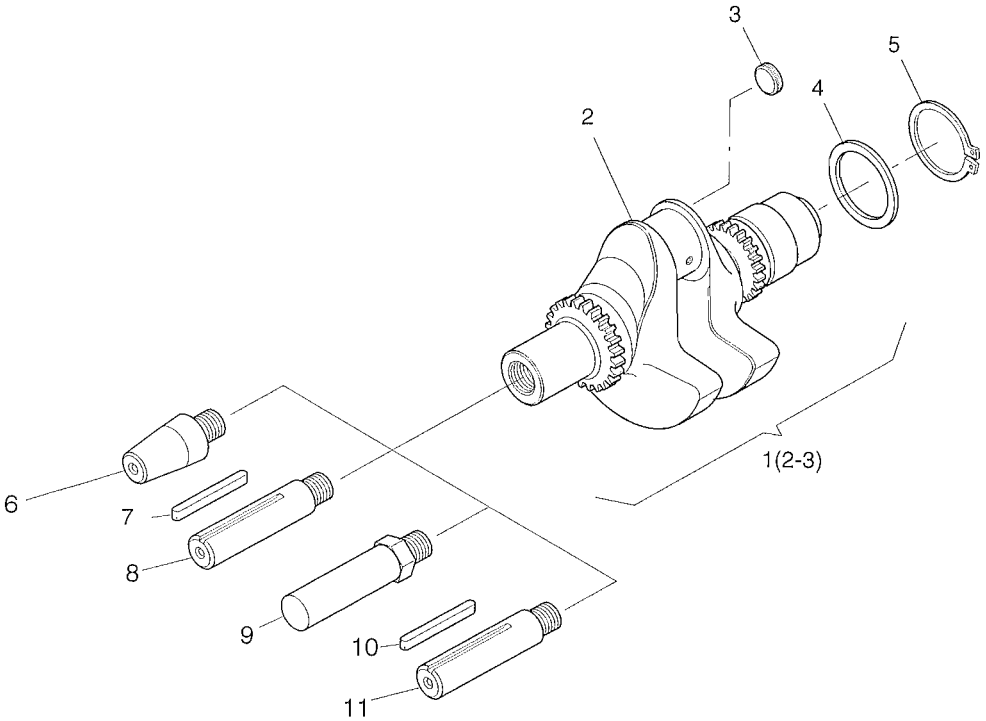

Fig.-No.	HATZ Ident-No.	Stück Qty.	P / W d / D	Bemerkungen Notes
1B40 V/W				
1	01370200	1		
2	-----	-		
3	04147300	1		Ø 14mm
4	50481400	1		50 x 62 x 3,0
5	50021800	1		A 50 x 2 DIN 471
6	05099700	1		Nr. 6 ital. 23 keg., con.
7	05141600	1		A 6,35 x 61
8	05127610	1		Nr. 2 - Ø 1" zyl., cil.
9	05107301	1		SW 27 mm Ø 26,8
10	50463400	1		A 5 x 5 x 36 DIN 6885
11	04152500	1		Ø 22,2 zyl., cil.

M 04

Nockenwelle
Camshaft
Arbre à cames
Arbol de levas
Albero a camme

Tafel Nr.
Tabl. No.
Tavola N.

06

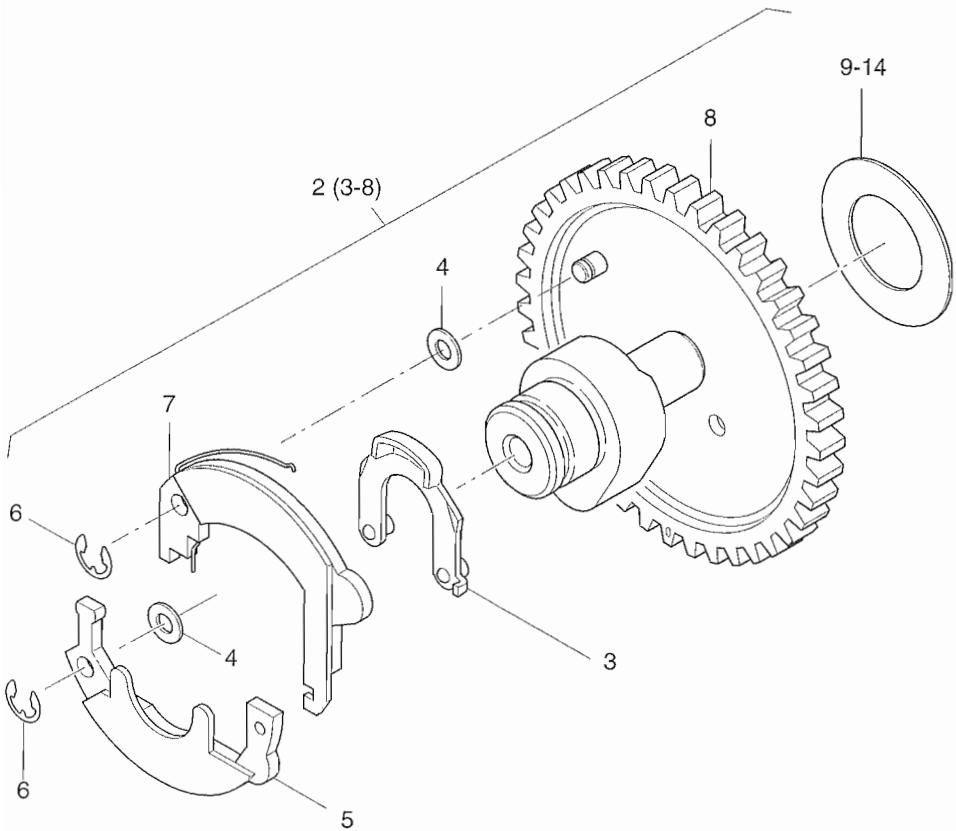

Fig.-No.	HATZ Ident-No.	Stück Qty.	P / W d / D	Bemerkungen Notes
		1B40 V/W		
2	01365100	0..1		
3	01326400	1		
4	50123200	2		5 x 10 x 0,5DIN 988
5	01326600	1		
6	50255300	2		3,2 DIN 6799
7	01364900	0..1		
8	01722500	1		E-Start
9	04121700	0..1		0,9 mm 23 x 38 x 0,9
10	04112100	0..1		1,0 mm 23 x 38 x 1,0
11	04112200	0..1		1,1 mm 23 x 38 x 1,1
12	04112300	0..1		1,2 mm 23 x 38 x 1,2
13	04125100	0..1		1,3 mm 23 x 38 x 1,3
14	04125200	0.. 1		1,4 mm 23 x 38 x 1,4

M 05

Kolben, Pleuel
Piston, Conrod
Piston, bielle
Embolo, biela
Pistone, biella

M 06

Zylinder
Cylinder
Cylindre
Cilindro
Cilindro

Tafel Nr.
Tabl. No.
Tavola N.

07

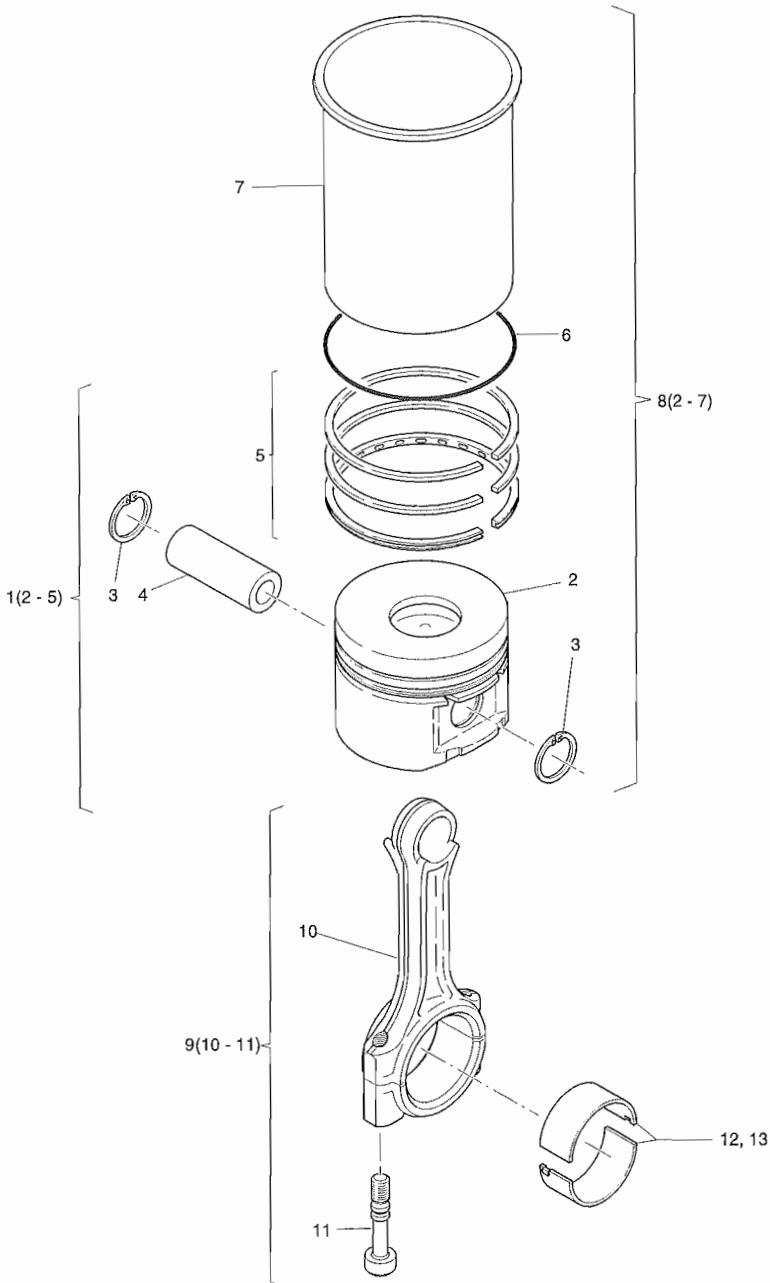

Fig.-No.	HATZ Ident-No.	Stück Qty.	P / W d / D	Bemerkungen Notes
1B40 V/W				
1	01346101	1		88 mm
2	-----	-		
3	50482300	2		
4	-----	-		
5	01346201	1		
6	50479301	1		93 x 1,5
7	-----	-		
8	01679600	1		
9	01343500	1		
10	-----	-		
11	04100500	2		
12	01679800	1		
13	01692700	1		- 0,5 mm

Fig.-No.	HATZ Ident-No.	Stück Qty.	P / W d / D	Bemerkungen Notes
1B40 V/W				
1	01596102	1		
2	-----	-		
3	05209700	2		
5	05159600	2		149 (M 10 - M 8)
6	05159700	2		155 (M 10)
7	01359900	2		
9	05145100	1		
10	05145200	1		
11	50425800	2	d2	
12	04147100	2		
13	04146900	2		
14	04147000	2		
15	50425700	2		
16	50445100	4		
17	05091101	2		
18	50513100	2	W2	M 8 x 10 DIN 916 - 45 H
19	05054700	2		
20	05146700	2		
21	05099300	4		10,1 x 24 x 3
22	50396600	4		M 10 DIN 934 - 10 A3C
23	05156401	1	d1,W4	
24	05146501	1		
28	50081200	3		A 6 DIN 137 A3C
29	50374900	3		M 6 x 35 DIN 912 - 8.8 A3C
30	04117701	1		
31	04126100	2		10 x 12 x 9
32	40028600	2		VM 10 DIN 980 - 8 C3A
33	05158802	0...1		0,3 mm
34	05158902	0...1		0,4 mm
35	05159002	0...1		0,5 mm
36	05159102	0...1		0,6 mm
37	05159202	0...1	d1	0,7 mm
38	05159302	0...1	d1	0,8 mm
39	05159402	0...1		0,9 mm
40	05159502	0...1		1,0 mm
41	50503100	2	d2	8 x 15
42	04174500	2		
43	04106500	2	d2	

M 10

Ölpumpe, Regler
 Oil pump, governor
 Pompe à huile, regulateur
 Bomba de aceite, regulador
 Pompa olio, regolatore

M 32

Drehzahlverstellung
 Speed control
 Réglage régime
 Ajuste de revoluc.
 Regolatore di giri

Tafel Nr.
 Tabl. No.
 Tavola N.

09

Fig.-No.	HATZ Ident-No.	Stück Qty.	P / W d / D	Bemerkungen Notes
1B40 V/W				
1	01344502	1		
2	-----	-		
3	50434901	1		RB 25 DIN 7993
4	-----	-		
5	-----	-		
6	04148400	1		
7	05097100	1		
8	50447900	1		3,5 mm Kl. III
9	50429400	4		M 5 x 12 DIN 6912 - 8.8
10	05097300	1		0,4 mm
11	01346000	1		
12	04153400	1		
13	40002600	2		3,2
14	05078600	1		
15	50434800	2		1,9 DIN 6799
16	01345901	1		
17	50422400	2		8 x 14 x 1,0 DIN 988
18	01365200	1		
19	50125800	1		8 x 14 x 0,5 DIN 988
20	05130900	1		
21	05130800	1		
22	05079800	1...5		
23	50465300	2		M 3 x 8 DIN 912 - 8.8
24	50435000	2		M 3 x 12 DIN 912 - 8.8
25	05148600	1		0,4 mm 19° ∠ } Gen. - PV 78 0,3 mm } 95138500 0,2 mm }
26	05078900	1		
27	05131600	1...3		
28	50144400	1		M 6 DIN 934 - 8 A3C
29	50144500	1		6,4 DIN 125 - St A3C
30	04095600	1		
31	50092700	4		7 DIN 6799 A3C
32	05079301	1		
33	03927300	1		M 6 x 32 8 x 2 FPM MOLYKOT.
34	04000200	1		
35	40022401	1	D1	8 x 2
36	05151700	1		

M 10

Ölpumpe, Regler
Oil pump, governor
Pompe à huile, régulateur
Bomba de aceite, regulador
Pompa olio, regolatore

M 32

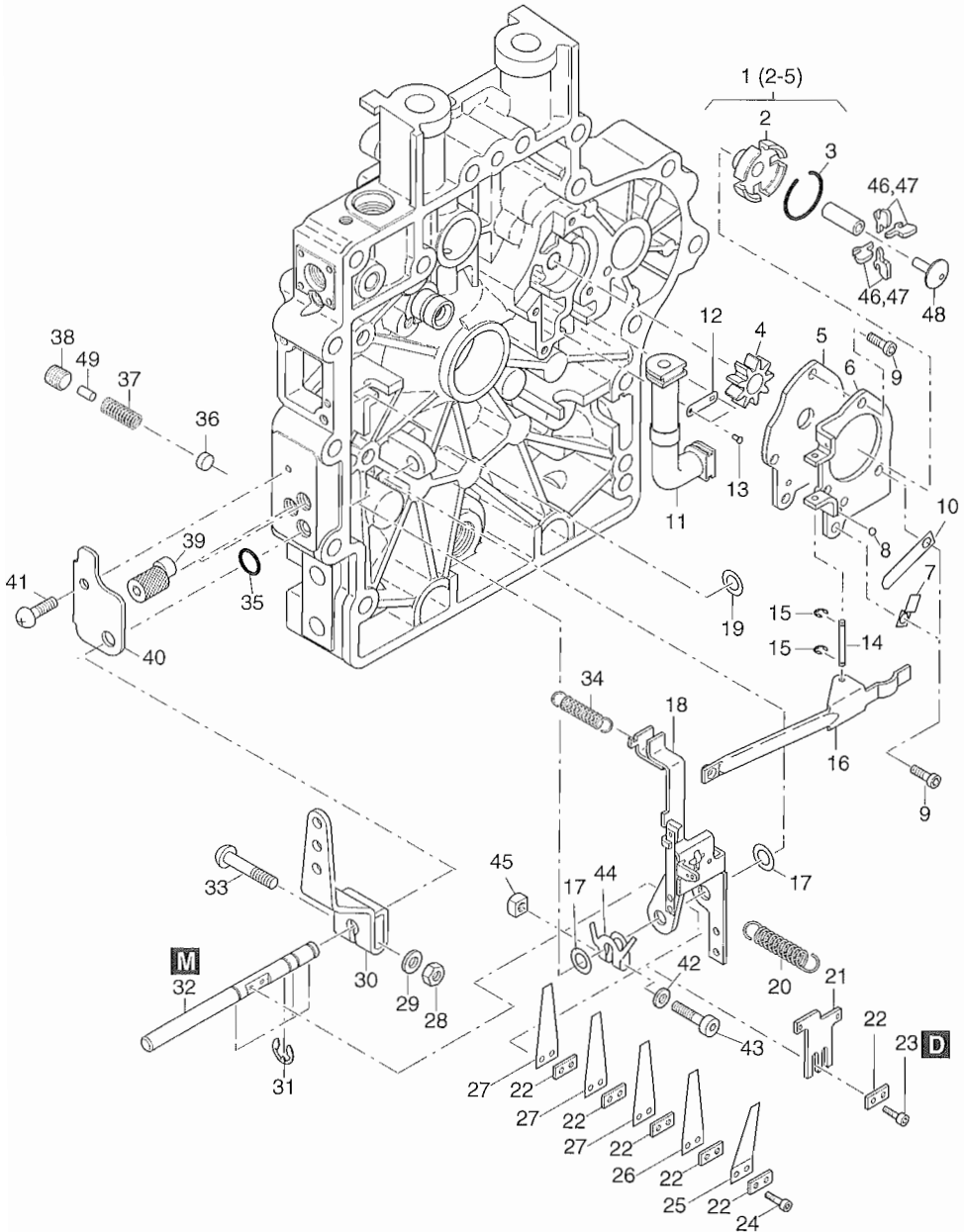
Drehzahlverstellung
Speed control
Réglage régime
Ajuste de revoluc.
Regolatore di giri

Tafel Nr.
Tabl. No.
Tavola N.

09

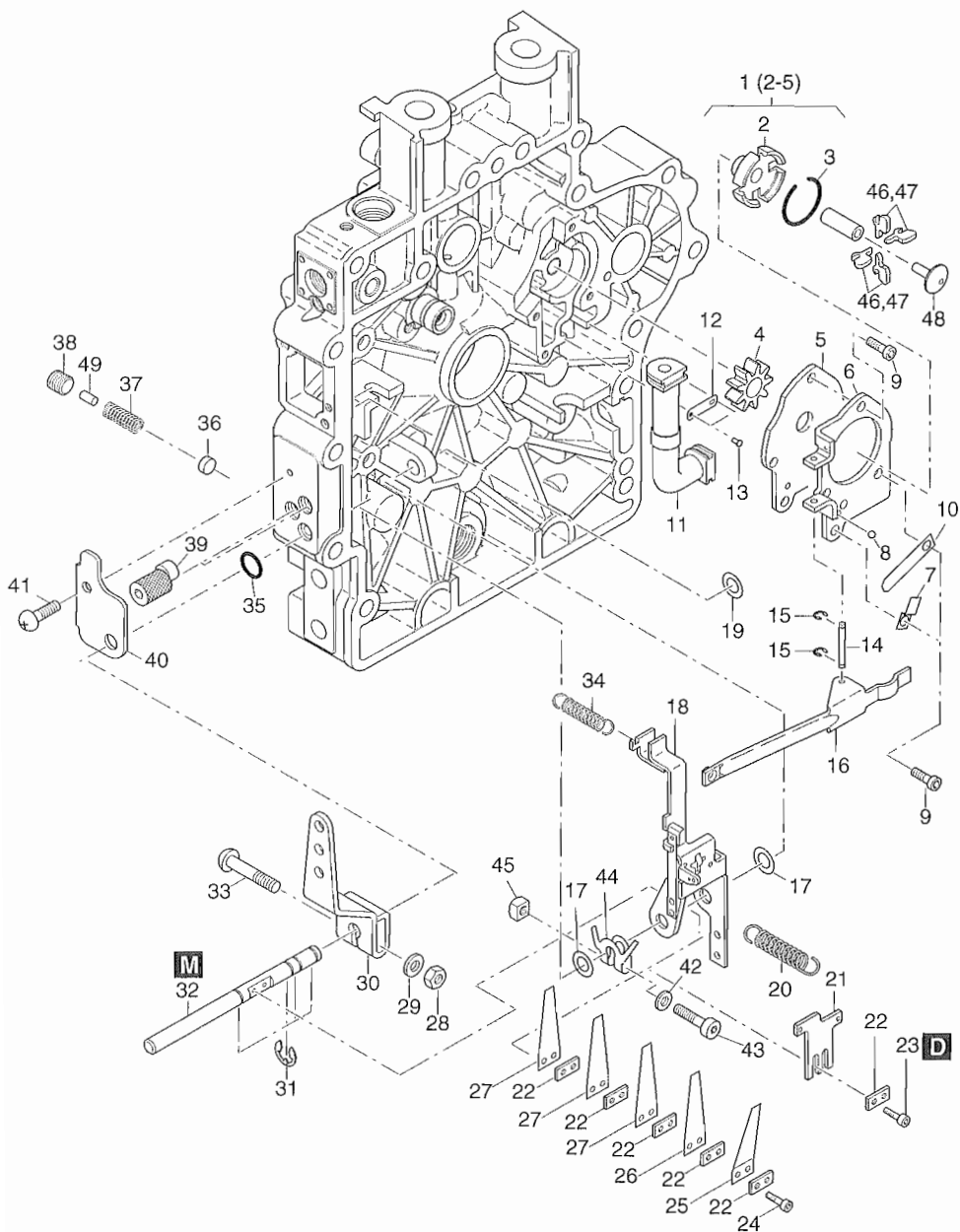

Fig.-No.	HATZ Ident-No.	Stück Qty.	P / W d / D	Bemerkungen Notes
1B40 V/W				
37	50488700	1		
38	50475700	1		M 10 x 10 DIN 913 - A3C TUF.
39	05178810	2		
40	05178400	1		
41	50492300	1		M 5 x 12 ISO 7380 - 10.9 Zn
42	50216300	1		5,3 DIN 125 - St A3C
43	50492200	1		M 5 x 25 DIN 6912 - 8.8
44	05178500	1		
45	50422700	1		M 5 DIN 557-5 A3C
46	05079602	8		
47	05160202	4		Gen. - PV 78 = 4
48	05078502	1		
49	50057900	1		

Fig.-No.	HATZ Ident-No.	Stück Qty.	P / W d / D	Bemerkungen Notes
1B40 V/W				
1	01704301	1		
2	-----	-		
3	04185800	1		4 x 9 "V"
4	50464100	1	D1	2 x 1 "V"
5	04185700	1		4 x 15 "V"
6	04168600	1		4,3 "W"
7	01344600	1		
8	04148800	2		
12	03794201	2		
13	50469900	2		M 6 x 30 DIN 912 - 10.9
14	50485600	1		13 x 19 x 10
15	01346700	1		
16	-----	-		
17	-----	-		
18	-----	-		
19	-----	-		
20	-----	-		
21	-----	-		
22	04152800	1		
23	04152701	1		
24	50422500	1		M 6 x 12 DIN 7991 - 8.8 A3C
25	04094700	1		
26	04095700	1		
27	04133900	1		10,7 x 16 x 0,5
28	04094802	1		
29	05095210	1		
30	50499300	1		M 6 x 35 DIN 913 - 22H A3C
31	50144400	1		M 6 DIN 934 - 8 A3C
32	50499400	1		M 4 x 25 DIN 915 - 45H
33	50384200	1		M 6 x 12 DIN 912 - 8 A3C TUF.
34	04095210	1		
35	50463000	2		M 8 x 130 DIN 912 - 8.8 A3C

M 11

Steuerdeckel
Timing cover
Couvercle distribution
Tapa de mando
Coperchio distribuzione

Tafel Nr.
Tabl. No.
Tavola N.

10

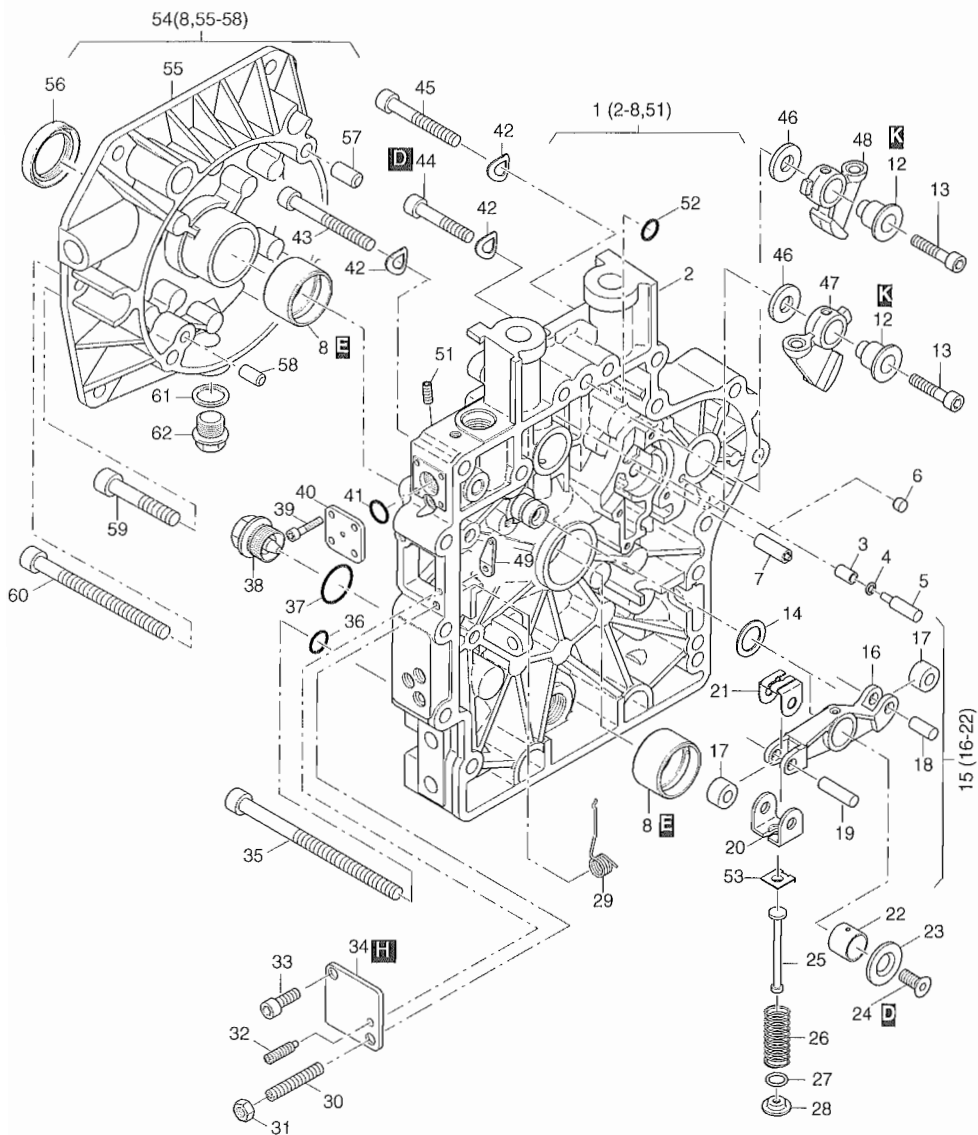

Fig.-No.	HATZ Ident-No.	Stück Qty.	P / W d / D	Bemerkungen Notes
1B40 V/W				
36	50162900	2		A 8 x 14 DIN 7603 - Cu
37	50459100	1	D1	A 22 x 27 DIN 7603 - Al
38	50373100	1	W1	AM 22 x 1,5 DIN 7604 A3C magn.
39	50397100	4		M 4 x 10 DIN 912 - 8.8 A3C TUF.
40	01351700	1		
41	50329000	1	D1	9,5 x 2,5
42	50095100	11		A 8 DIN 137 A3C
43	50288800	8		M 8 x 55 DIN 912 - 8.8 A3C
44	50177500	2		M 8 x 40 DIN 912 - 8.8 A3C
45	50392900	1		M 8 x 50 DIN 912 - 8.8 A3C
46	03794100	2		10,1 x 22 x 3
47	04146600	1		
48	04146000	1		
49	05127100	1		
51	50262400	1		M 6 x 10 DIN 916 - TUF. 360
52	40022300	1	D1	8 x 2
53	04189500	1		
54	01713800	1		
55	-----	-		
56	50479500	1	D1	35 x 47 x 7
57	50058800	1		10 m 6 x 24 DIN 7-9S20K
58	50502801	1		8 m 6 x 24 DIN 6325 2 Fasen
59	50361800	2		M 10 x 50 DIN 912-8.8 A3C
60	50059701	4		M 8 x 100 DIN 912-8.8 A3C
61	50001400	2		A 18 x 22 DIN 7603-Cu
62	50044200	2		M 18 x 1,5 DIN 910

M 13

Gebälse
Blower
Soufflerie
Ventilador
Ventilatore

M 17

Schwungrad
Flywheel
Volant
Volante
Volano

Tafel Nr.
Tabl. No.
Tavola N.

11

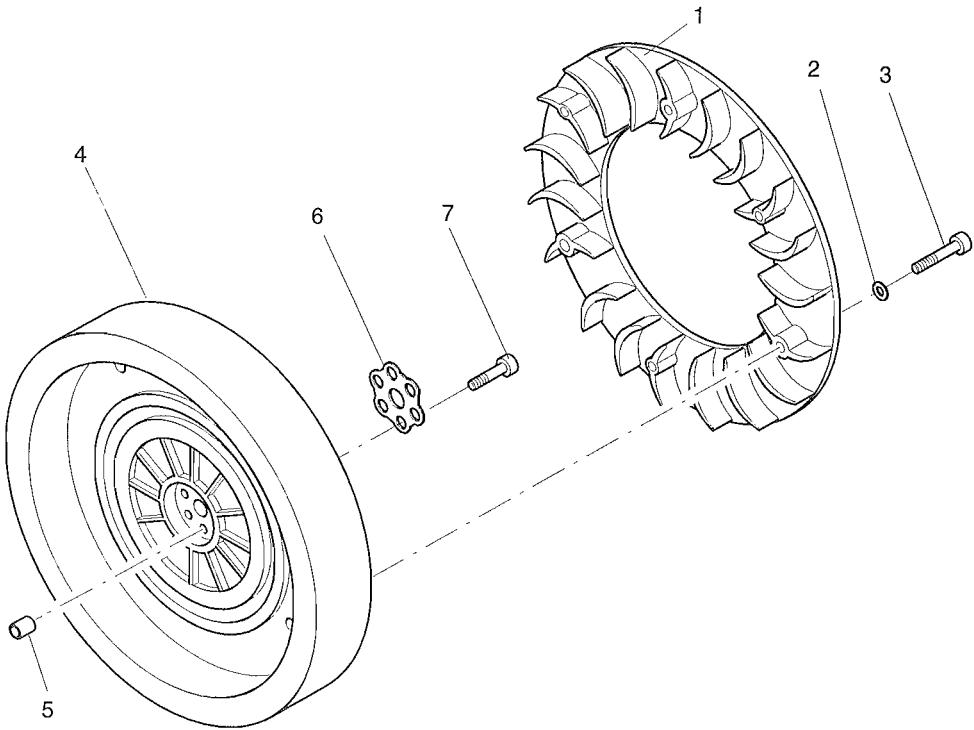

Fig.-No.	HATZ Ident-No.	Stück Qty.	P / W d / D	Bemerkungen Notes
1B40 V/W				
1	01347501	1		
2	50003400	6		A 4 DIN 137
3	50327300	6		M 4 x 20 DIN 912 - 8.8 A3C
4	04153901	1		Handstart
5	50205600	1		10 x 12 DIN 7346 55 SI 7
6	04155101	1		
7	50502500	6		M 8 x 35 DIN 912 - 12.9 A3C

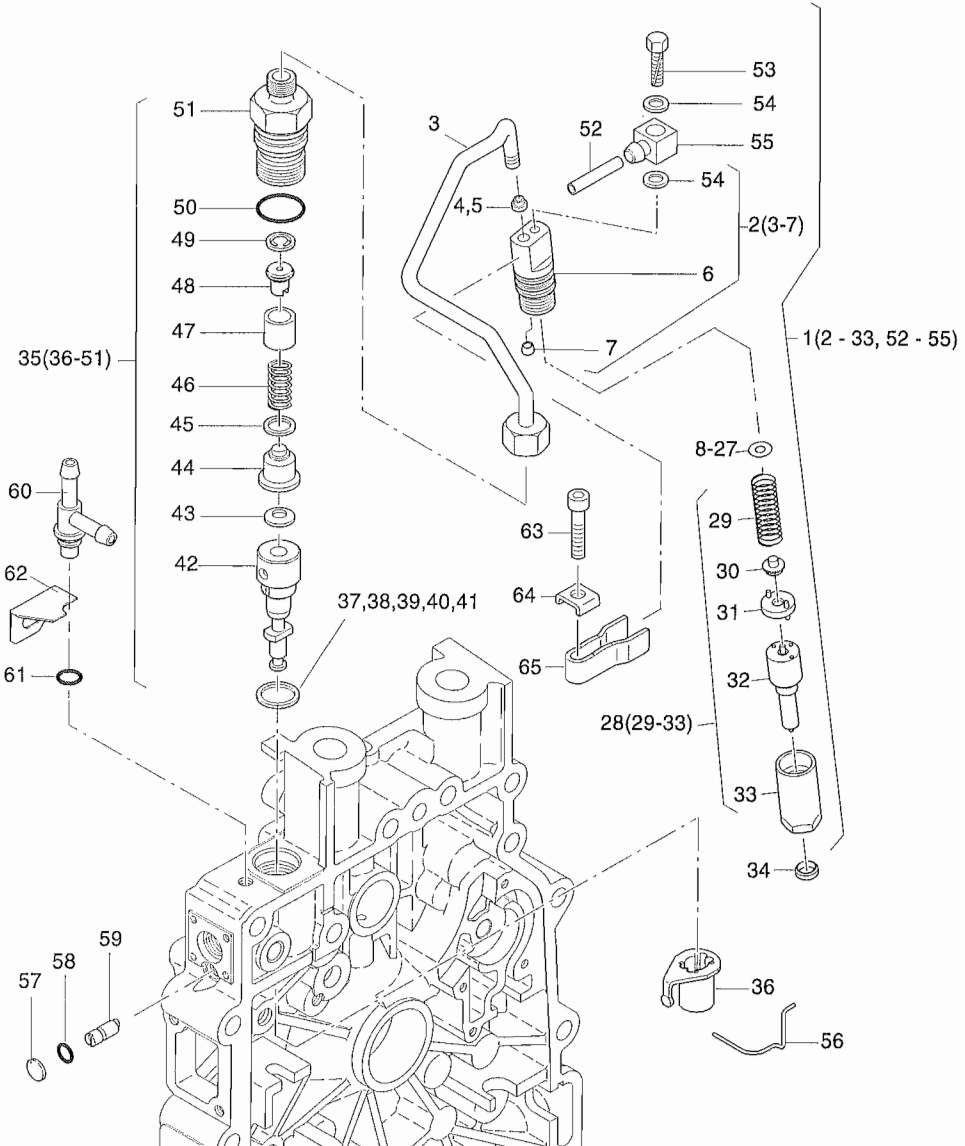

Fig.-No.	HATZ Ident-No.	Stück Qty.	P / W d / D	Bemerkungen Notes
1B40 V/W				
1	01372000	1		
2	01680600	1		
3	-----	-		
4	05096101	0...1		4,9 mm
5	05070601	0...1		5,3 mm
6	-----	-		
7	05081500	0...1		BOSCH
8	50436400	0...1		1,00 mm
9	50436500	0...1		1,04 mm
10	50436600	0...1		1,10 mm
11	50436700	0...1		1,14 mm
12	50436800	0...1		1,20 mm
13	50436900	0...1		1,24 mm
14	50437000	0...1		1,30 mm
15	50437100	0...1		1,34 mm
16	50437200	0...1		1,40 mm
17	50437300	0...1		1,44 mm
18	50437400	0...1		1,50 mm
19	50437500	0...1		1,54 mm
20	50437600	0...1		1,60 mm
21	50437700	0...1		1,64 mm
22	50437800	0...1		1,70 mm
23	50437900	0...1		1,74 mm
24	50438000	0...1		1,80 mm
25	50438100	0...1		1,84 mm
26	50438200	0...1		1,90 mm
27	50438300	0...1		1,94 mm
28	01347400	1		
29	-----	-		
30	-----	-		
31	-----	-		
32	50501200	1	P1	
33	-----	-		
34	05070500	1	d1	
35	01680800	1		
36	01330801	1		

s. 95125801

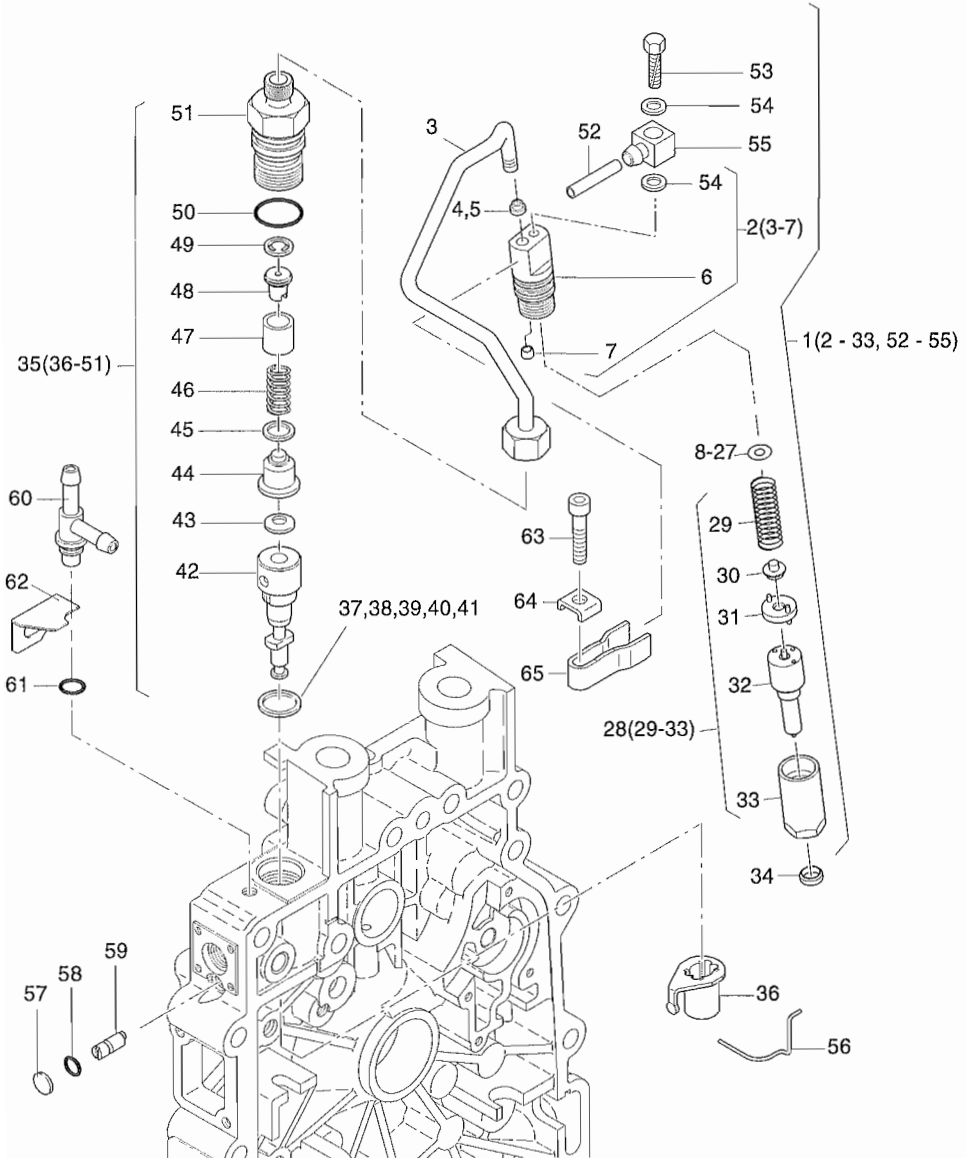

Fig.-No.	HATZ Ident-No.	Stück Qty.	P / W d / D	Bemerkungen Notes
1B40 V/W				
37	04096300	0...1		0,2 mm
38	04096400	0...1		0,3 mm
39	04096500	0...1		0,4 mm
40	04096600	0...1		0,5 mm
41	04096700	0...1		0,6 mm
42	-----	-		
43	04165200	1		8
44	-----	-		
45	50476900	1		9,5 x 13 x 0,5
46	-----	-		
47	05181000	1		9,2 x 12,8
48	05180900	1		
49	05180800	1		
50	50489200	1		17 x 2
51	05181100	1		
52	05220200	1		2,5 x 330
53	50464500	1		AM 4 x 16 DIN 7315
54	50110800	2		A 4 x 8 DIN 7603 - Cu
55	05129000	1		
56	04161800	1		
57	50476000	1		8 DIN 470 AI
58	50330100	1		4 x 1,2
59	04097710	1		
60	05183000	1		
61	50154300	1	D1	7,5 x 1,5
62	05183100	1		
63	50323900	1		M 6 x 30 DIN 912 - 8.8 A3C
64	05089300	1		6,4
65	05056700	1		

M 15

Reversierstarter
Recoil starter
Demarreur reversible
Arrancador reversible
Avviamento a strappo

Tafel Nr.
Tabl. No.
Tavola N.

13

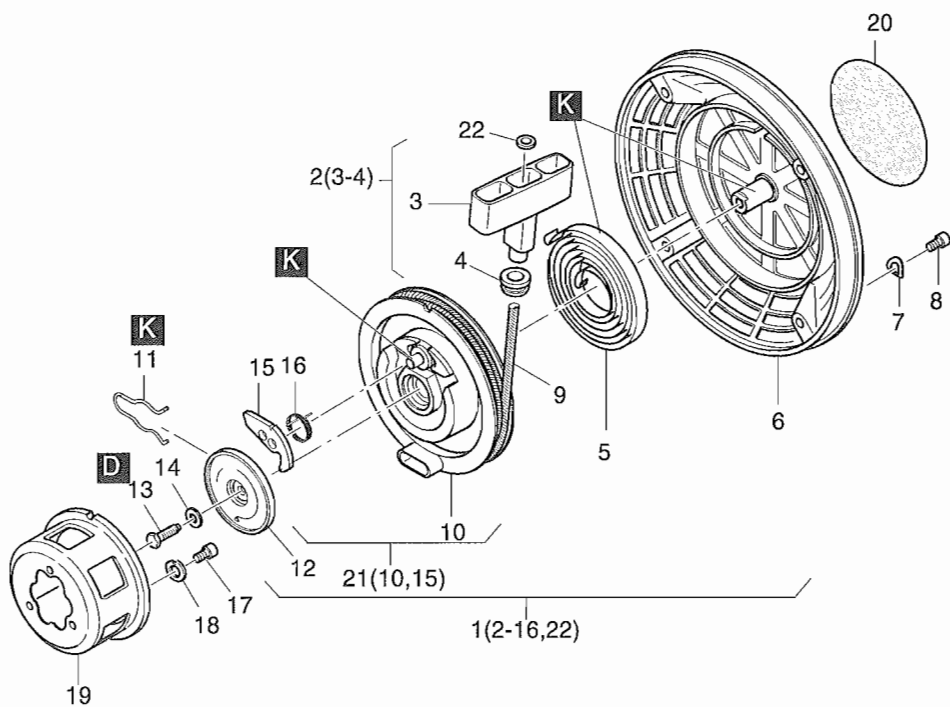

Fig.-No.	HATZ Ident-No.	Stück Qty.	P / W d / D	Bemerkungen Notes
1B40 V/W				
1	01515002	1		
2	01497800	1		
3	-----	-		
4	03665200	1		
5	05045201	1		
6	01569300	1		
7	50081200	4		A 6 DIN 137 A3C
8	50062700	4		M 6 x 10 DIN 912 - 8.8 A3C
9	05088901	1		1750 mm
10	-----	-		
11	05044901	1		
12	05045001	1		
13	50146300	1		M 6 x 18 DIN 933 - 8.8 A3C
14	50165600	1		6,5 x 14 DIN 6904 - A3C
15	05044800	1		
16	05061300	1		
17	50062700	3		M 6 x 10 DIN 912 - 8.8 A3C
18	50170900	3		6 DIN 128 A3C
19	04155000	1		
20	05109100	1		
21	01548800	1		
22	50514600	1		5,3 DIN 9021 PA 6.6

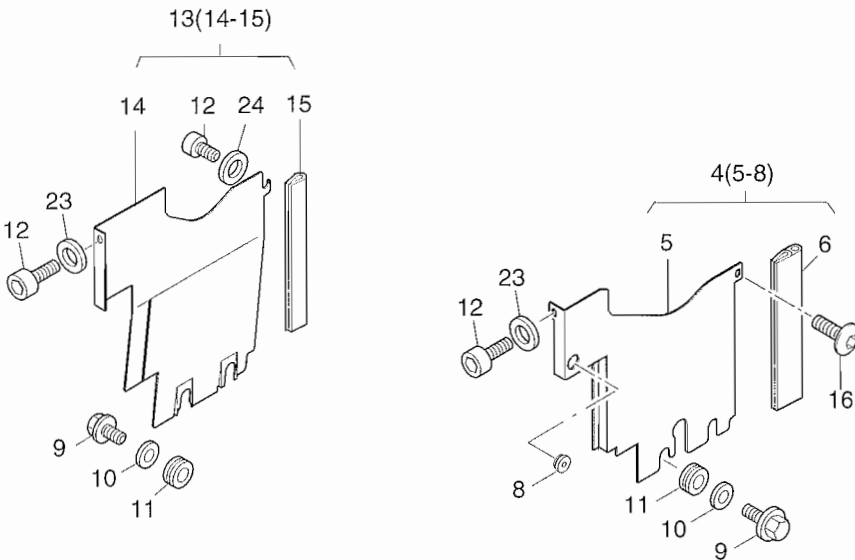
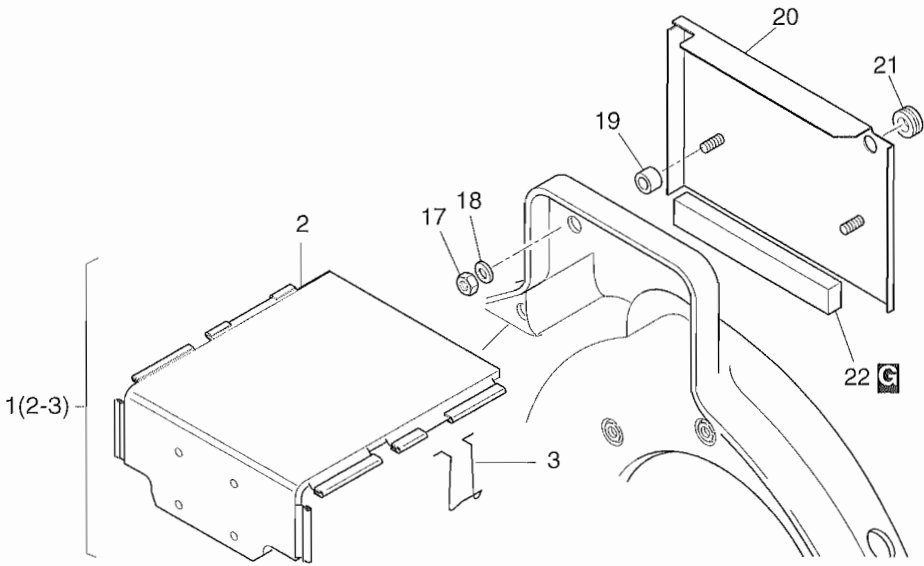

Fig.-No.	HATZ Ident-No.	Stück Qty.	P / W d / D	Bemerkungen Notes
1B40 V/W				
1	01610400	1		
2	-----	-		
3	05152100	1		
4	01345400	1		
5	-----	-		
6	04144200	1		93 mm
8	50334800	1		
9	50445400	4		M 4 x 10
10	50441600	4		4,3 DIN 9021 - A3C 140VH
11	50163801	4		
12	50474200	3		M 6 x 16 DIN 912-8.8 Tuf.360
13	01345300	1		
14	-----	-		
15	04144200	1		93 mm
16	50495000	1		M 6 x 12 DIN 7380 - 10.9 A3C
17	50144400	2		M 6 DIN 934 - 8 A3C
18	50170900	2		6 DIN 128 - A3C
19	03354600	2		7 x 12 x 8
20	01698200	1		
21	50334800	1		
22	03577200	1		14 x 9 x 125
23	50144500	2		6,4 DIN 125 St-A3C
24	04060600	1		6,4 x 16 x 1,5 A3C

M 26

Luftführung
Air ducting
Carter ventilation
Conducción de aire
Carter ventilatore

Tafel Nr.
Tabl. No.
Tavola N.

15

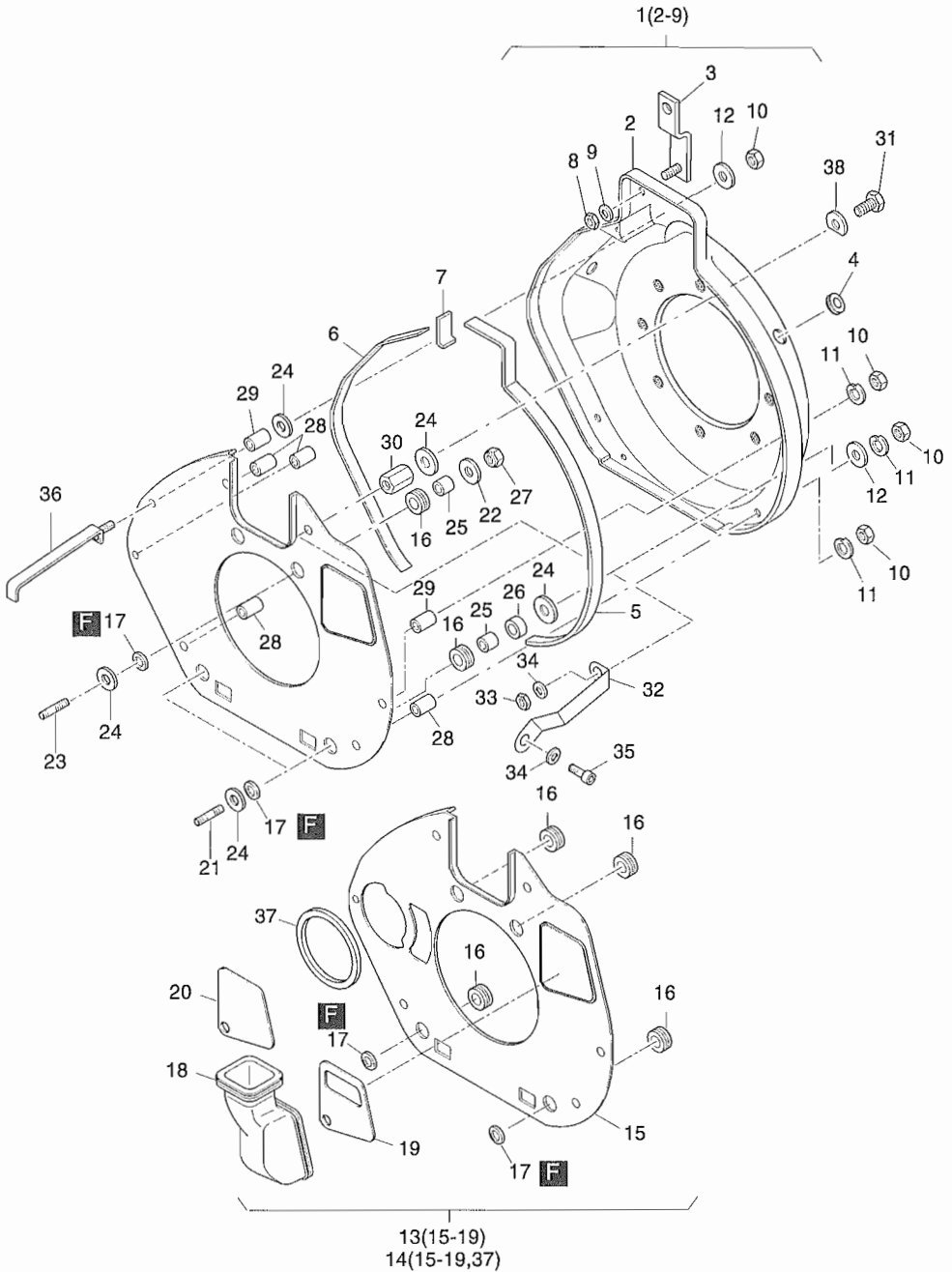

Fig.-No.	HATZ Ident-No.	Stück Qty.	P / W d / D	Bemerkungen Notes
1B40 V/W				
1	01668910	1		
2	-----	-		
3	01331300	2		
4	50453300	1		
5	05189400	1		655 mm
6	05189300	1		520 mm
7	05007300	1		48 mm
8	50144400	2	M 6	DIN 934 - 8 A3C
9	50170900	2	6	DIN 128 A3C
10	50144400	7	M 6	DIN 934 - 8 A3C
11	50170900	8	6	DIN 128 A3C
12	50120000	3	A 6,4	DIN 9021 St A3C
13	01661900	1		Handstart
14	01347600	1		E-Start
15	-----	-		
16	00921400	4		
17	03575500	4		
18	04146800	1		
19	04150700	0...1		
20	04150800	0...1		
21	50458100	2	M 6 x 45	DIN 835 - 8.8 A3C
22	50114300	2	6,4	DIN 7349 A3C
23	50464401	2	M 6 Fo x 35	DIN 939.8.8 A3C TUF
24	04042000	7		6,5 x 22 x 1
25	04119100	4		6 x 8 x 14
26	05188600	2		7 x 12 x 7
27	50328300	2	VM 6	DIN 980 - 8 A3C
28	04139000	4		6,5 x 12 x 18
29	04098400	2		7 x 12 x 16,3
30	05184000	1		M 6 x 17
31	50026400	1	M 6 x 35	DIN 933 - 8.8 A3C
32	01669400	1		
33	50144400	1	M 6	DIN 934 - 8 A3C
34	50170900	2	6	DIN 128 A3C
35	50170700	1	M 6 x 16	DIN 912 - 8.8 A3C
36	01683300	1		
37	04099500	1		
38	05140900	1		

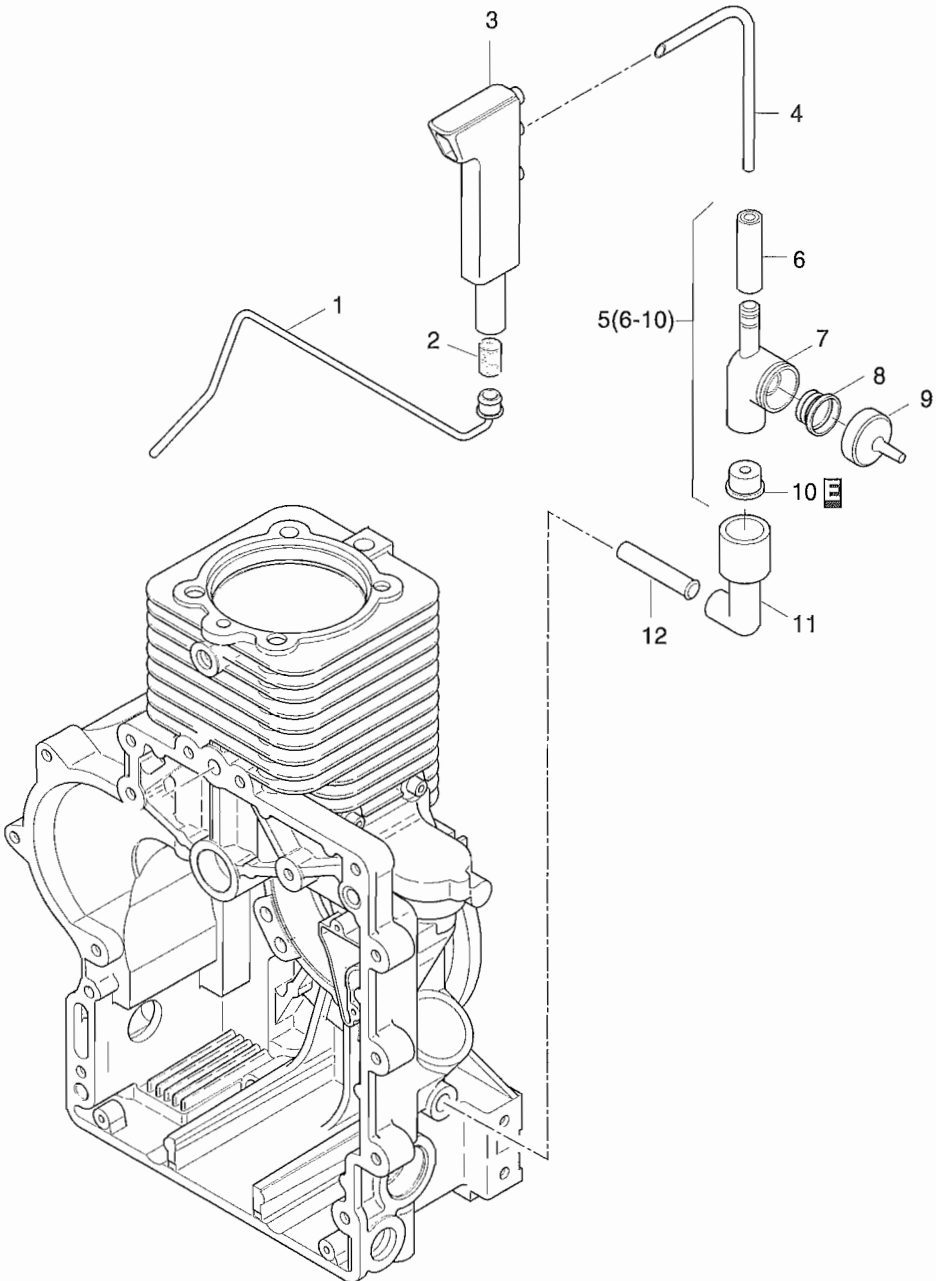

Fig.-No.	HATZ Ident-No.	Stück Qty.	P / W d / D	Bemerkungen Notes
		1B40 V/W		
1	01372600	1		
2	05102900	1		Filter, Filtre, Filtro
3	04202100	1		
4	04202000	1		
5	01373500	1		
6	01373200	1		
7	-----	-		
8	03568700	1		
9	03568600	1		
10	-----	-		
11	04136100	1		
12	-----	-		

A 01

Kraftstoffbehälter
Fuel tank
Reservoir à carburant
Depósito combustible
Serbatoio

Tafel Nr.
Tabl. No.
Tavola N.

17

1(2-22)

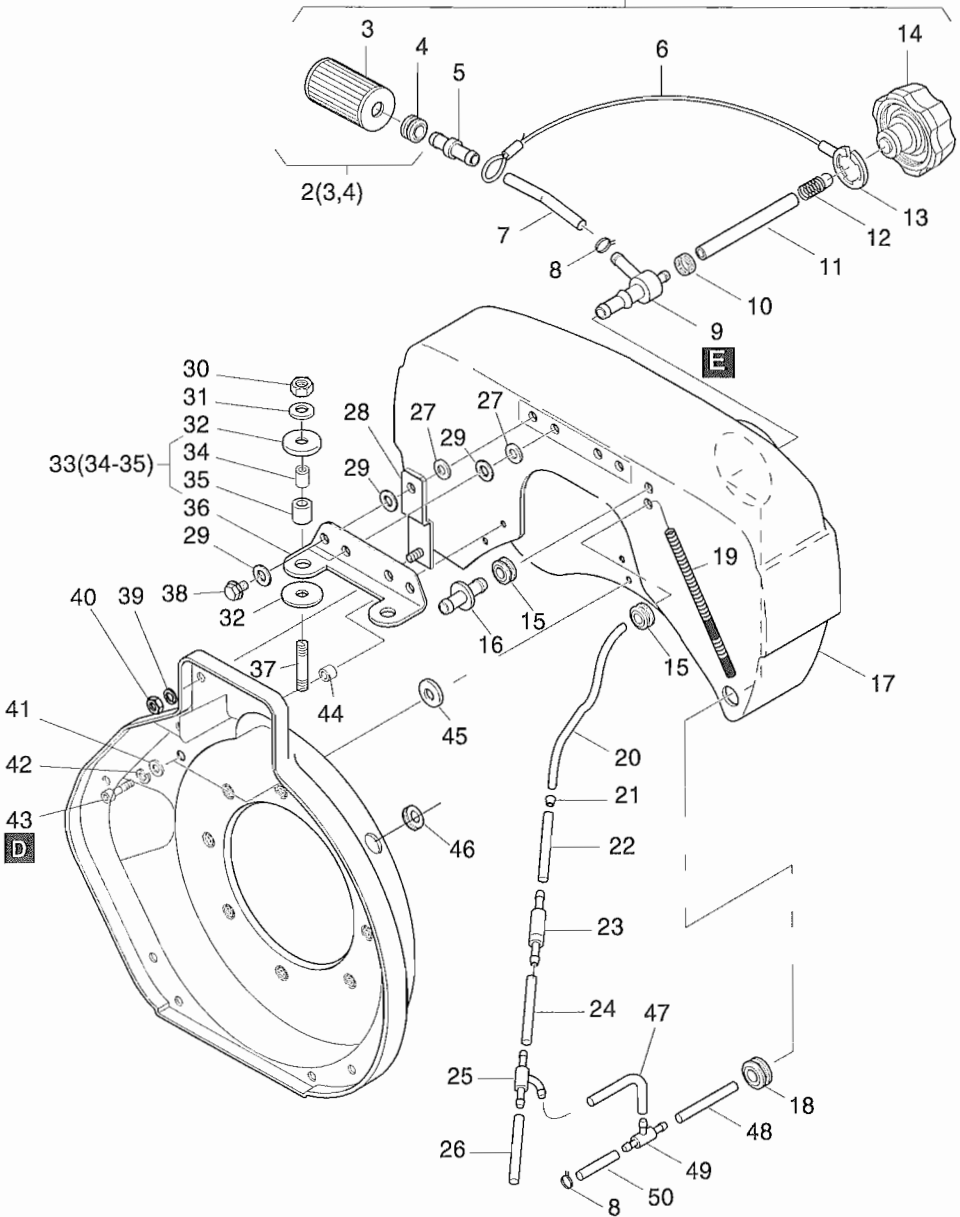

Fig.-No.	HATZ Ident-No.	Stück Qty.	P / W d / D	Bemerkungen Notes
1B40 V/W				
1	01702500	1		
2	01635200	1		
3	-----	-		
4	50440901	1		
5	05084401	1		
6	01702300	1		≈ 440 mm
7	03493600	1		7 x 330
8	50441100	2		11,8 - 505 R
9	01623900	1		
10	50480100	1		7,0 - 505 R
11	05130300	1		2,5 x 295
12	50479200	1		
13	50480000	1		20 x 1 DIN 984
14	01620301	1		
15	05130400	2		
16	05129610	1		
17	-----	-		
18	50440800	1		
19	01648500	1		160 mm
20	05205100	1		
21	05126500	1		
22	05188800	1		4,5 x 120
23	01534600	1		
24	05123200	1		3,5 x 40
25	05122701	1		
26	05085300	1		3,5 x 45
27	50120000	4		A 6,4 DIN 9021 St A3C
28	01331300	2		
29	05110010	10		7,1 x 17,9 x 2
30	40028400	2		VM 8 DIN 980-8 C3A
31	50148100	2		8,4 DIN 125-St A3C
32	05109810	4		8,2 x 22 x 2
33	01655800	2		
34	-----	-		
35	-----	-		
36	05170110	1		

A 01

Kraftstoffbehälter
Fuel tank
Reservoir à carburant
Depósito combustible
Serbatoio

Tafel Nr.
Tabl. No.
Tavola N.

17

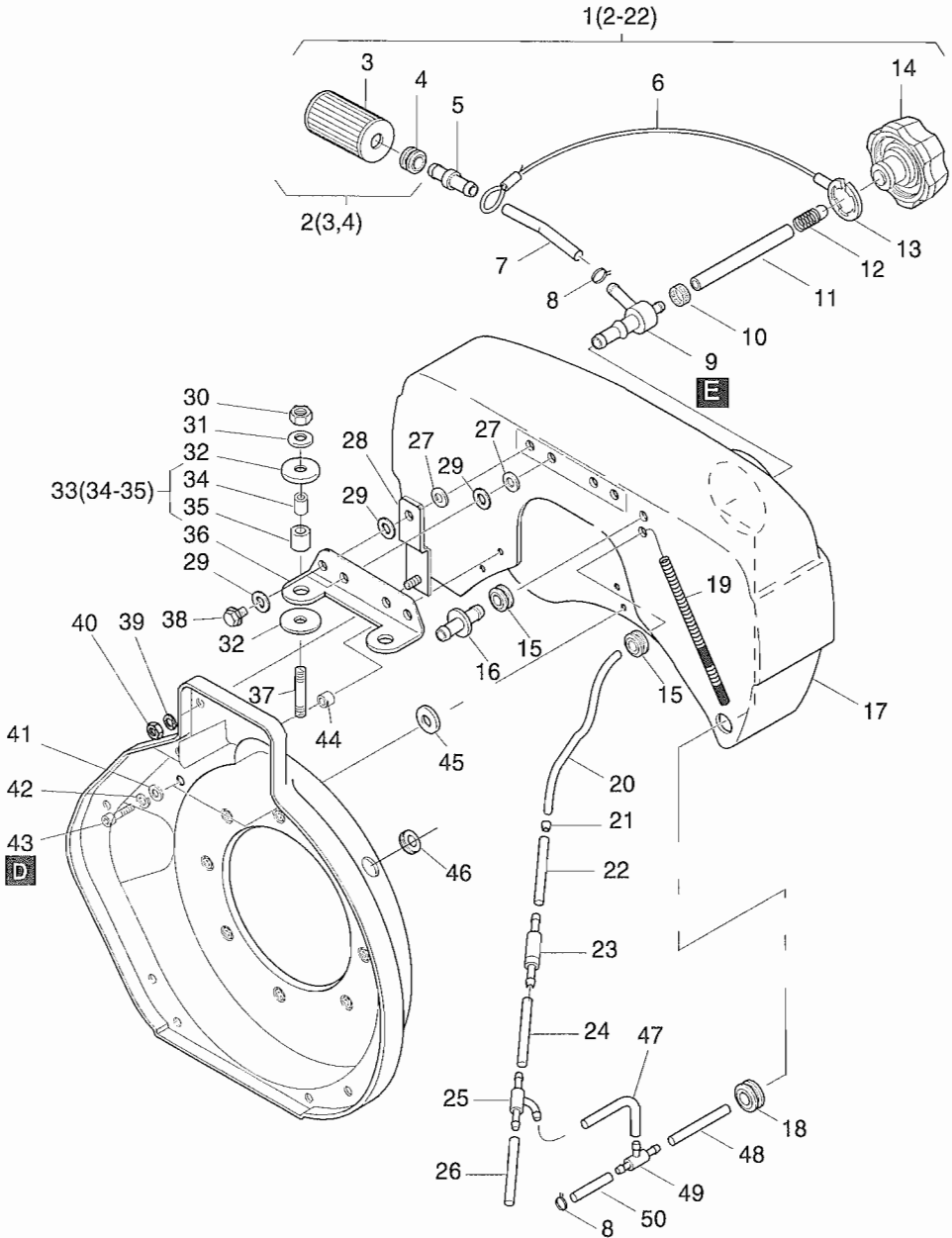

Fig.-No.	HATZ Ident-No.	Stück Qty.	P / W d / D	Bemerkungen Notes
1B40 V/W				
37	50231900	2	M 8 x 25	DIN 835 - 8.8 A3C
38	01557000	4	M 6 x 18	
39	50170900	2	6	DIN 128 A3C
40	50144400	2	M 6	DIN 934 - 8 A3C
41	50120000	4	A 6,4	DIN 9021 St A3C
42	50170900	4	6	DIN 128 A3C
43	50170700	4	M 6 x 16	DIN 912 - 8.8 A3C
44	04118800	2	6,5 x 13 x 4,8	
45	04042000	2	6,5 x 22 x 1	
46	50453300	1		
47	03673300	1	4,5 x 170	
48	05090000	1	7 x 120	
49	50459600	1		
50	03493100	1	7 x 60	

A 02

Luftfilter
Air filter
Filtre à air
Filtro de aire
Filtro aria

Tafel Nr.
Tabl. No.
Tavola N.

18

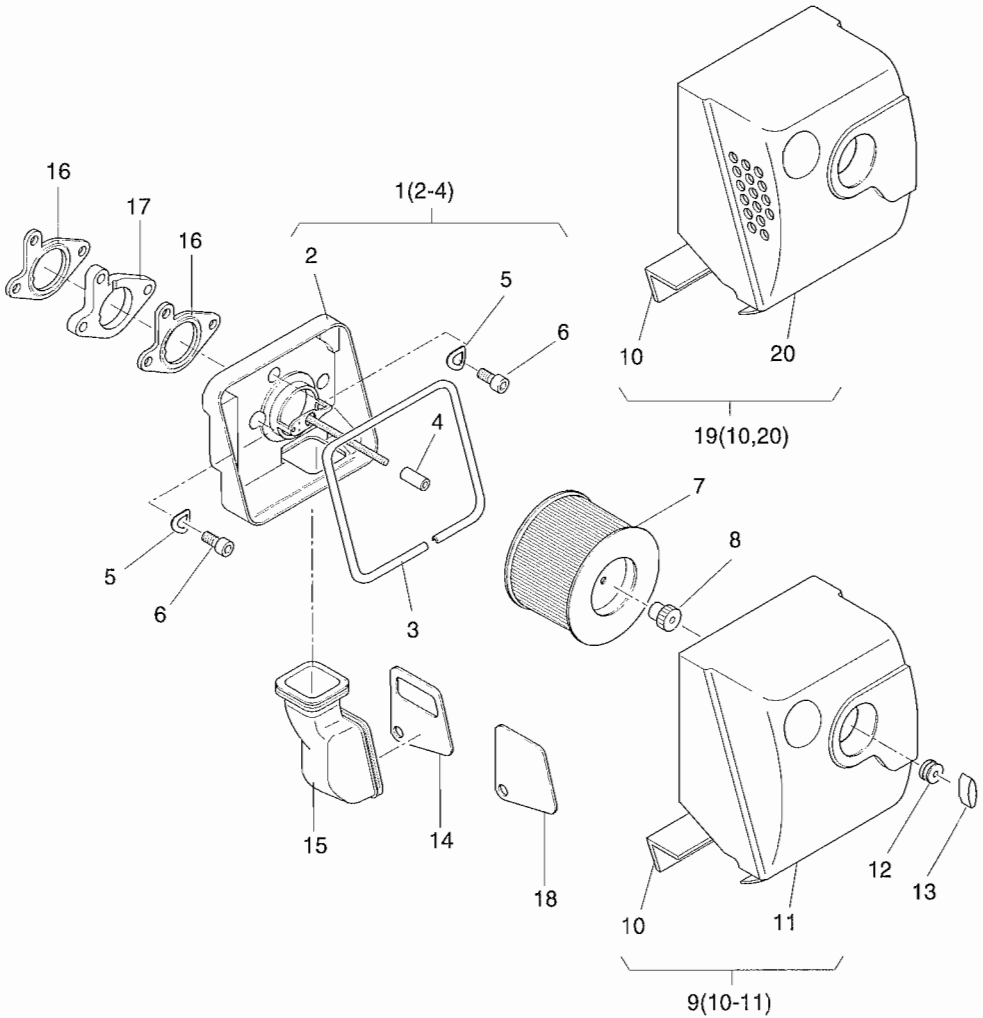

Fig.-No.	HATZ Ident-No.	Stück Qty.	P / W d / D	Bemerkungen Notes
1B40 V/W				
1	01637400	1		
2	-----	-		
3	05167700	1		675 mm
4	05166200	1		32 mm
5	50095100	3		A 8 DIN 137 A3C
6	50171500	3		M 8 x 25 DIN 912 - 8.8 A3C
7	50484100	1	W2	
8	50454300	1		M 6
9	01637300	1		
10	05158000	1		180 mm
11	-----	-		
12	50435800	1		
13	50452200	1		M 6
14	04150800	0...1		
15	04146800	1		
16	05149900	2	d2	
17	01695800	1		
18	04150700	0...1		
19	01691100	1		
20	-----	-		

Fig.-No.	HATZ Ident-No.	Stück Qty.	P / W d / D	Bemerkungen Notes
1B40 V/W				
1	01682500	1		
2	-----	-		
3	05199700	1		650 mm
4	50429600	3		M 8 x 35 DIN 912-8.8 C4P
5	04054300	3		8,4 x 21 x 3
6	50487200	12		4,8 x 13
7	-----	-		
8	05157400	5	d5	
10	40028300	1		M 6 SSN 440 - 8 - C3P
11	50144500	1		6,4 DIN 125 - St A3C
12	01655601	1		
13	05177900	1		M 6
14	50170700	1		M 6 x 16 DIN 912 - 8.8 A3C
15	50114300	1		6,4 DIN 7349 - A3C
16	50165500	1		M 6 x 12 DIN 933 - 8.8 A3C
17	50114300	1		6,4 DIN 7349 - A3C
18	50422500	2		M 6 x 12 DIN 7991 - 8.8 A3C
19	01629000	1		
20	50170900	1		6 DIN 128 A3C
21	01701600	1		
22	-----	-		

A 05

Starter, Generator
Starter, alternator
Démarrreur, alternateur
Arrancador, alternador
Motorino avviamento, alternatore

Tafel Nr.
Tabl. No.
Tavola N.

20

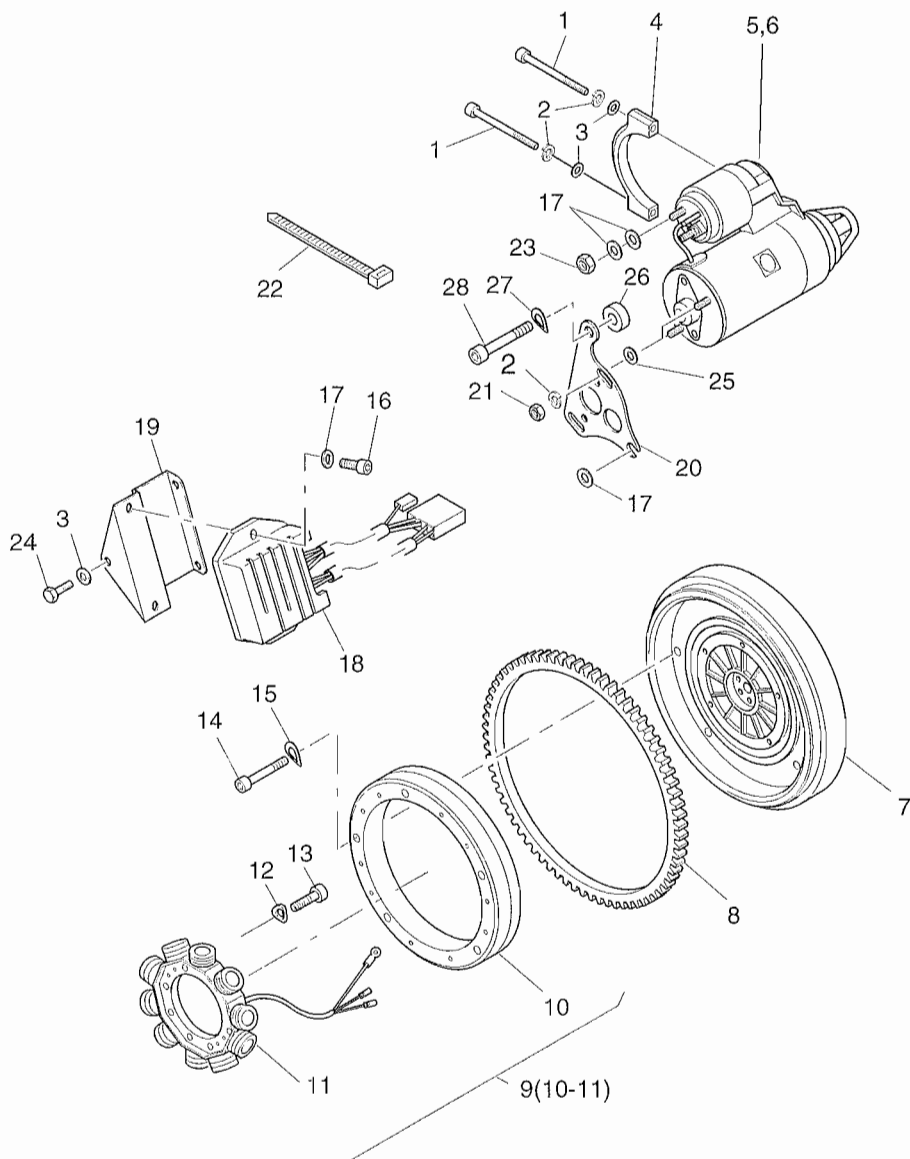

Fig.-No.	HATZ Ident.-No.	Stück Qty.	P / W d / D	Bemerkungen Notes
1B40 V/W				
1	50402300	2		M 6 x 70 DIN 912 - 8.8 A3C
2	50170900	4		6 DIN 128 A3C
3	50144500	3		6,4 DIN 125 - St A3C
4	04099100	1		
5	50524600	1		12 V 1,2 kW
6	50483400	1		24 V 1,6 kW
7	04161502	1		
8	04151100	1		
9	50495100	1		12 V - 200 W
10	-----	-		
11	-----	-		
12	50081900	4		A 5 DIN 137 A3C
13	50427100	4		M 5 x 25 DIN 912 - 8.8 A3C
14	50236600	5		M 6 x 25 DIN 6912 - 8.8 A3C
15	50081200	5		A 6 DIN 137 A3C
16	50165400	2		M 8 x 16 DIN 912 - 8.8 A3C
17	50148100	6		8,4 DIN 125 - St A3C
18	05100701	1		12 V
19	01663000	1		
20	05182912	1		
21	50144400	2		M 6 DIN 934 - 8 A3C
22	50439500	3		2,6 x 200
23	50023200	1		BM 8 DIN 439 - 5 A3C
24	50025400	1		M 6 x 10 DIN 933 - 8.8 A3C
25	50120000	2		A 6,4 DIN 9021 - St A3C
26	03714100	1		8 x 18 x 7
27	50095100	1		A 8 DIN 137 A3C
28	50392900	1		M 8 x 50 DIN 912-8.8 A3C

A 05
A 10

Armaturen, Leitungen
Electric equipment, wirings
Équipement électrique, cable
Equipo eléctrico, cables
Equipaggiamento elettrico, cablaggio

Tafel Nr.
Tabl. No.
Tavola N.

21

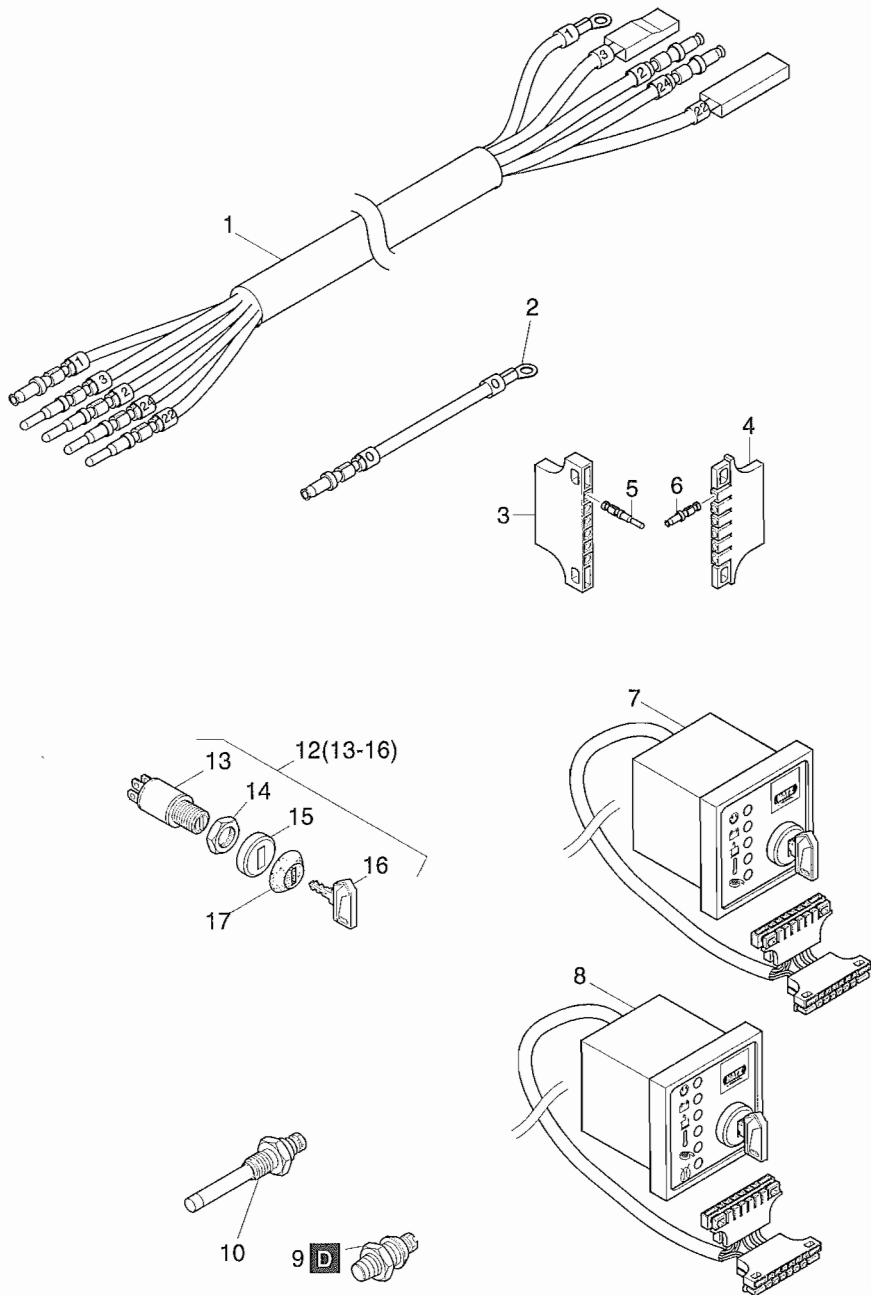

Fig.-No.	HATZ Ident-No.	Stück Qty.	P / W d / D	Bemerkungen Notes
1B40 V/W				
1	01667000	1		
2	01548300	1		
3	50373600	1		
4	50373700	1		
5	50374100	5		0,5 - 1,0
6	50373900	6		1,5 - 2,5
7	01551802	1		12 V
8	01558901	1		12 - 24 V Aut.
9	50469100	1		Oil
10	50268600	1		Temp.
12	50384401	1		
13	-----	-		
14	-----	-		
15	-----	-		
16	50404900	1		Nr. 14644
17	05126402	1		

A 09

Drehzahlverstellung für Bowdenzug
Speed control for Bowden-cable
Reglage régime pour câble bowden
Ajuste de revolutiones para cable bowden
Comando acceleratore per bowden

Tafel Nr.
Tabl. No.
Tavola N.

22

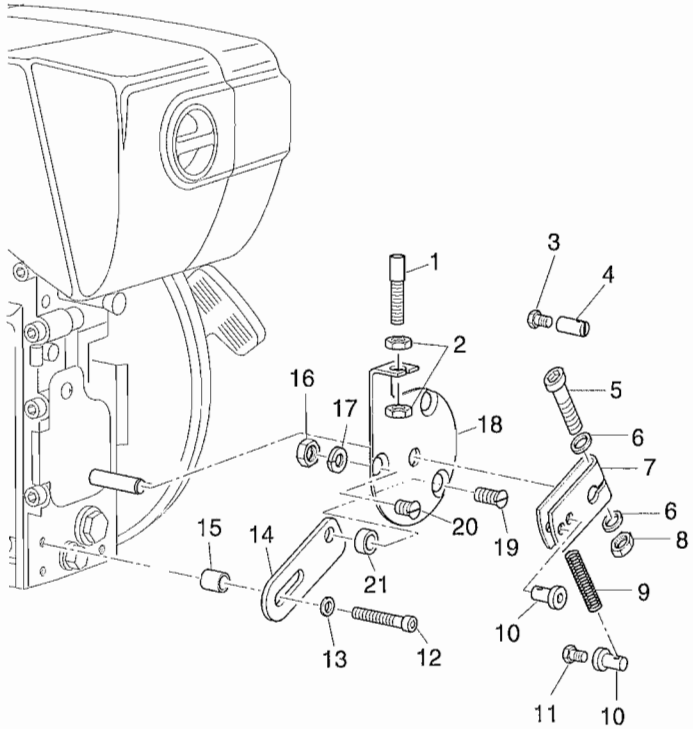

Fig.-No.	HATZ Ident-No.	Stück Qty.	P / W d / D	Bemerkungen Notes
1B40 V/W				
1	05141200	1		M 6
2	50144400	2		M 6 DIN 934 - 8 A3C
3	50025000	1		M 4 x 10 DIN 933-8.8A3C
4	50483000	1		2,2 NR.1120
5	50427100	1		M 5 x 25 DIN 912 - 8.8 A3C
6	50216300	2		5,3 DIN 125 - St A3C
7	05117700	1		
8	50094300	1		M 5 DIN 934 - 8 A3C
9	50484600	1		VD-179E
10	50483100	2		2,2 NR.1450
11	50025000	1		M 4 x 10 DIN 933-8.8A3C
12	50342400	1		M 8 x 50 DIN 6912 - 8.8 A3C
13	50148100	1		8,4 DIN 125 - St A3C
14	05189600	1		
15	03599700	1		8,5 x 13 x 14,5
16	50328300	1		VM 6 DIN 980 - 8 A3C
17	50208500	1		8 DIN 128 A3C
18	05117600	1		
19	50423900	1		M 6 x 20 DIN 7991 - 10.9 A3C
20	50380800	1		M 6 x 10 DIN 7991 - 8.8 A3C
21	03292900	1		8,2 x 11 x 12

A 18

Anbauteile Hydraulikpumpe
Mount. parts hydr. pump
Pièces mont.-pompe hydr.
Piezas mont. bomba hydr.
Particorari per montaggio pompa idraulica

Tafel Nr.
Tabl. No.
Tavola N.

23

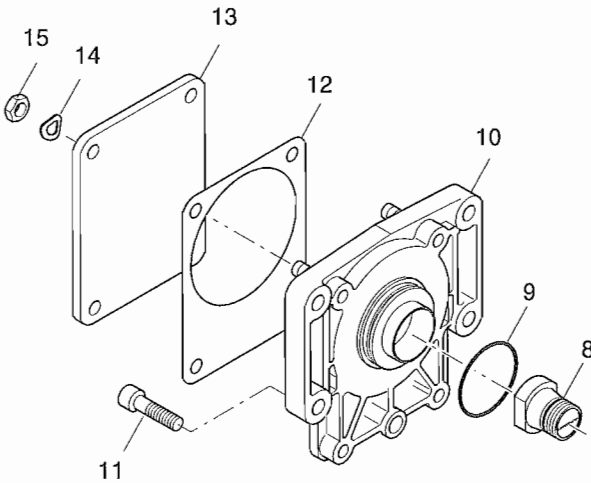
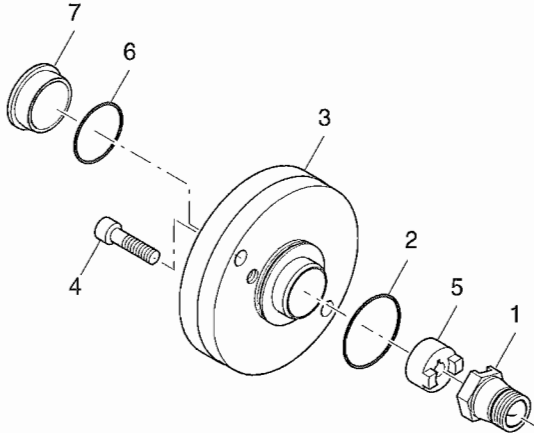

Fig.-No.	HATZ Ident-No.	Stück Qty.	P / W d / D	Bemerkungen Notes
1B40 V/W				
1	01558100	1		
2	50454500	1		44 x 1,5
3	05212200	1		(BOSCH)
4	50175900	2		M 8 x 30 DIN 912 - 8.8 A3C
5	05114700	1		
6	50288200	1		32 x 2,5
7	50163101	1		F 25 Ø 38,8
8	01558000	1		
9	50454500	1		44 x 1,5
10	01690901	1		(BOSCH)
11	50494300	4		M 8 x 20 DIN 912 - 8.8 Tuf.
12	03568000	1		
13	03761600	1		
14	50095100	4		A 8 DIN 137 A3C
15	50148000	4		M 8 DIN 934 - 8 A3C

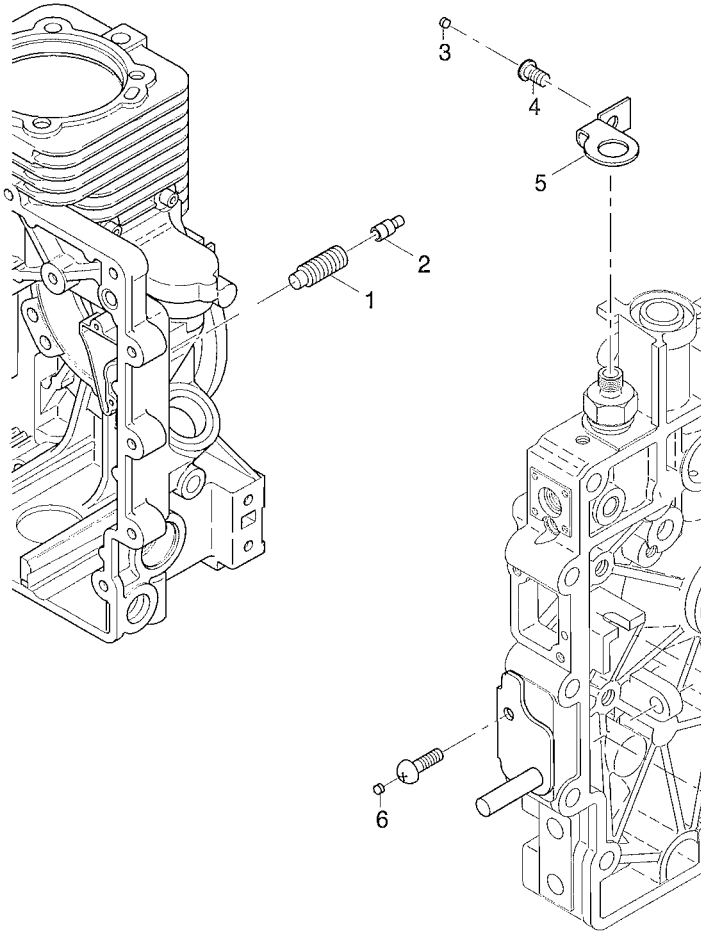

Fig.-No.	HATZ Ident-No.	Stück Qty.	P / W d / D	Bemerkungen Notes
1B40 V/W				
1	04198800	1		
2	04150500	1		
3	04170600	1		4,15
4	50495000	1		M 6 x 12 DIN 7380-10.9 A3C
5	04195700	1		
6	05201500	1		3

Serien-Nr.-Änderungen
Serial-code modification list
Modification des Nos de serien
Modificación de los Nos de serie
Modifica dei codici

IMT-No.

1 B 40 V / W.10

1 B 40 V / W.11

01.613

