

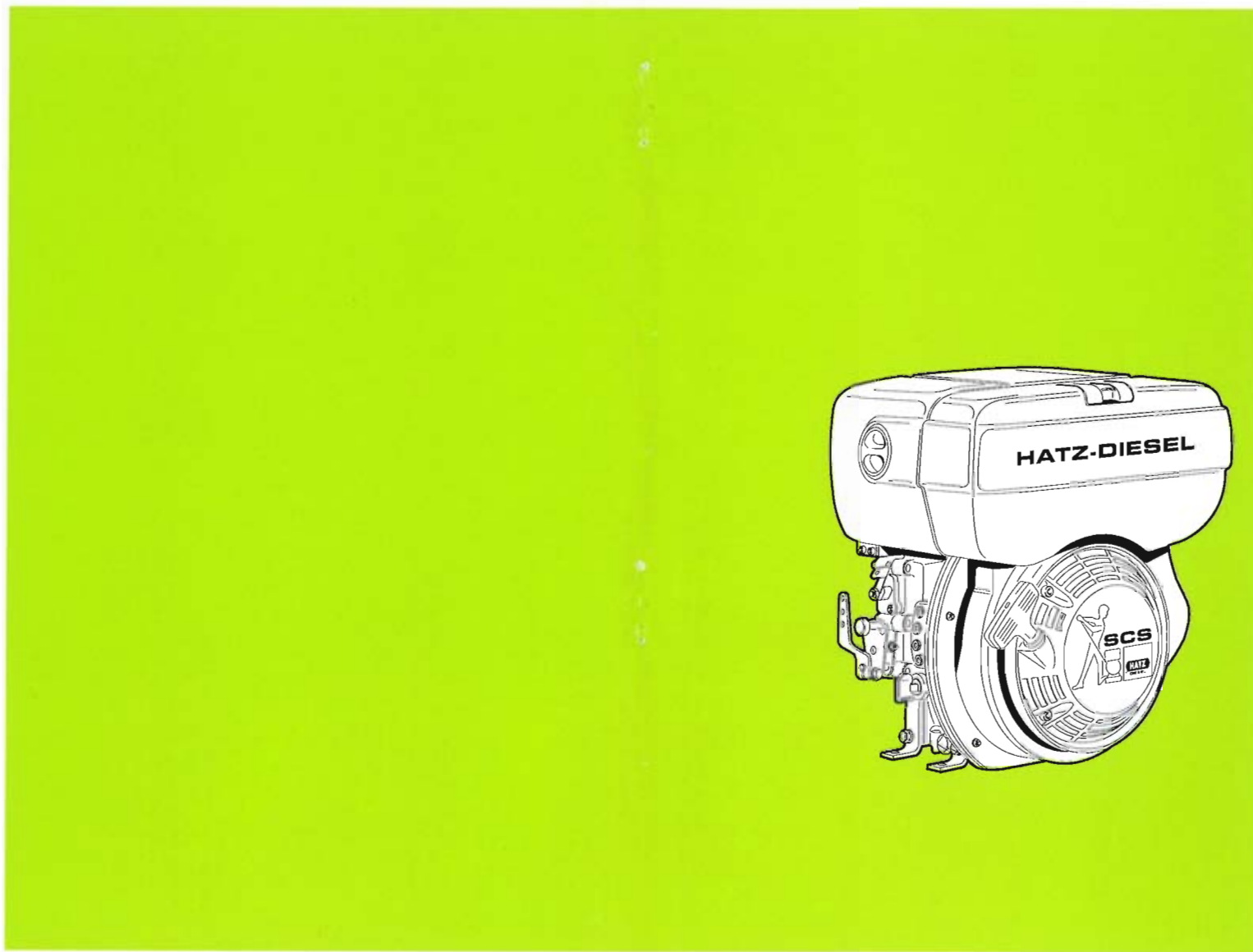

MOTORENFABRIK HATZ • D-94099 Ruhstorf • Germany  
Tel.: 0 85 31 / 319-0 • Telefax: 0 85 31 / 31 94 18  
eMail: marketing@hatz-diesel.de • <http://www.hatz-diesel.com>

# Original-Ersatzteile

Original-spare parts  
Pièces de rechange d'origine  
Repuestos originales  
Pezzi di ricambio originali



434 840 02-02.01-0.2  
Printed in Germany

# 1B40

# Bestellung für HATZ-Original-Ersatzteile

Order for HATZ Original spare parts

Commande de pièces d'origine HATZ

Pedido de repuestos originales HATZ

Ordine parti di ricambio originali HATZ

1

Besteller / Customer / Client / Cliente / Cliente

2

TYP

MOTOR/FABRIK NO.

MIN-1



3

Ersatzteilliste Nr./ Spare parts list no./ Liste des pièces de rechange no./ Lista de repuestos No./ Lista ricambi n.

1 B 40.11

4

Stück / Qty / Q.tà	HATZ Ident No.	Stück / Qty / Q.tà	HATZ Ident No.

5

Versandart / Mode of dispatch / Mode d'expédition / Despacho deseado / Modo di spedizione

Post / Surface / Poste / Correo / Posta

Luftfracht / airfreight / frêt aérien / flete aereo / Via aerea

Express / express / exprès / expreso / Espresso

.....

6

Versandadresse / Consignee / Adresse destination / Dirección / Indirizzo di destinazione

Bestellung an: Order at: Commande à: Pedido a:

- die nächste HATZ-Servicestelle (siehe Servicestellenverzeichnis)

- your nearest HATZ service station (see service-list)

- votre station-service HATZ la plus proche (voir liste "Service")

- al servizio HATZ más cercano (ver cuaderno de Servicio)

- al più vicino centro di servizio HATZ (vedi lista centri autorizzati)

**MOTORENFABRIK HATZ**

**D-94099 RUHSTORF**

Tel: 0 85 31 / 319 - 0

Fax: 0 85 31 / 31 94 21



	<b>Inhaltsverzeichnis</b>	<b>Index</b>	
<b>M ..</b>	<b>Grundmotor</b>	<b>Basic engine</b>	
00	Ersatzteilsätze	Spare part kits	01
34	Zubehör	Accessories	02
01	Kurbelgehäuse	Crankcase	03
01	Massenausgleich	Compensation of masses	04
02	Kurbelwelle	Crankshaft	05
04	Nockenwelle	Camshaft	06
05, 06	Kolben, Pleuel, Zylinder	Piston, conrod, cylinder	07
07	Zylinderkopf	Cylinder head	08
10, 32	Ölpumpe, Regler Drehzahlverstellung	Oil pump, governor speed control	09
11	Steuerdeckel	Timing cover	10
13,17	Gebälse, Schwungrad	Blower, flywheel	11
14	Einspritzausrüstung	Injection equipment	12
15	Reversierstarter	Recoil starter	13
26	Luftführung	Air ducting	14,15
31	Kurbelgehäuseentlüftung	Crankcase breathing system	16
<b>A ..</b>	<b>Zusatzausrüstung</b>	<b>Equipments</b>	
01	Kraftstoffbehälter	Fuel tank	17
02	Luftfilter	Air filter	18
03	Abgasdämpfer	Exhaust silencer	19
05	Starter, Generator,	Starter, alternator,	20
05, 10	Armaturen, Leitungen	Electric equipment, wirings	21
09	Drehzahlverstellung	Speed control	22
09	Drehzahlverstellung-Bowdenzug	Speed control for Bowden-cable	23
18	Anbauteile-Hydraulikpumpe	Mount. parts hydr. pump	24
90	Motorausrüstung EPA	Spec. equipment EPA	25

**Sommaire:**

**Indice**

M ..

**Moteur de base**

**Motor de base**

00	Jeu de pièces de rechange	Juegos de piezas de recambios	01
34	Accessoires	Accesorios	02
01	Carter moteur	Caja cigueñal	03
01	Equilibrage des masses	Compensación de las masas	04
02	Vilebrequin	Cigüeñal	05
04	Arbre à cames	Arbol de levas	06
05, 06	Piston, bielle, cylindre	Emboio, biela, cilindro	07
07	Culasse	Culata	08
10, 32	Pompe à huile, regulateur regime, réglage regime	Bomba de aceite, regulador, ajuste de revoluciones	09
11	Couvercle distribution	Tapa de mando	10
13,17	Soufflerie, volant	Ventilador, volante	11
14	Equipment d'injection	Equipo de inyección	12
15	Demarreur reversible	Arrancador reversible	13
26	Carter ventilation	Conducción de aire	14,15
31	Reniflard	Purgador	16

A ..

**Accessoires**

**Equipos**

01	Reservoir à carburant	Depósito combustible	17
02	Filtre à air	Filtro de aire	18
03	Silencieux	Silenciador	19
05	Demarreur, alternateur	Arrancador, alternador	20
05, 10	Equipement électrique, cable	Equipo eléctrico, cables	21
09	Reglage régime	Ajuste de velocidad	22
09	Reglage régime p. câble bowden	Ajuste de velocidad p. cable bowden	23
8	Pièces mont.-pompe hydr.	Piezas mont. bomba hidr.	24
00	Equip. spec. EPA	Equipo espec. EPA	25

**M .. Motore de base**

00	Serie guarnizioni	01
34	Kit accessori	02
01	Basamento motore	03
01	Masse controrotanti	04
02	Albero a gomito	05
04	Albero a camme	06
05, 06	Pistone, biella, cilindro	07
07	Testa	08
10, 32	Pompa olio, regolatore di giri, Comando acceleratore	09
11	Coperchio distribuzione	10
13, 17	Ventilatore, volano	11
14	Equipaggiamento di iniezione	12
15	Avviamento a strappo	13
26	Carter ventilatore	14,15
31	Sfiato basamento	16

**A .. Accessori**

01	Serbatoio	17
02	Filtro aria	18
03	Scarico	19
05	Motorino avviamento, alternatore,	20
05, 10	Equipaggiam. elettrico, cablaggio	21
09	Comando acceleratore	22
09	Comando acceleratore per bowden	23
18	Particorari per montaggio pompa idraulica	24
90	Kit trasformazione EPA	25

Ersatzteilsätze  
Spare part kits  
Jeux de pièces de rechange  
Juegos de piezas de recambios  
Serie guarnizioni

Tafel Nr.  
Tabl. No.  
Tavola N.

01

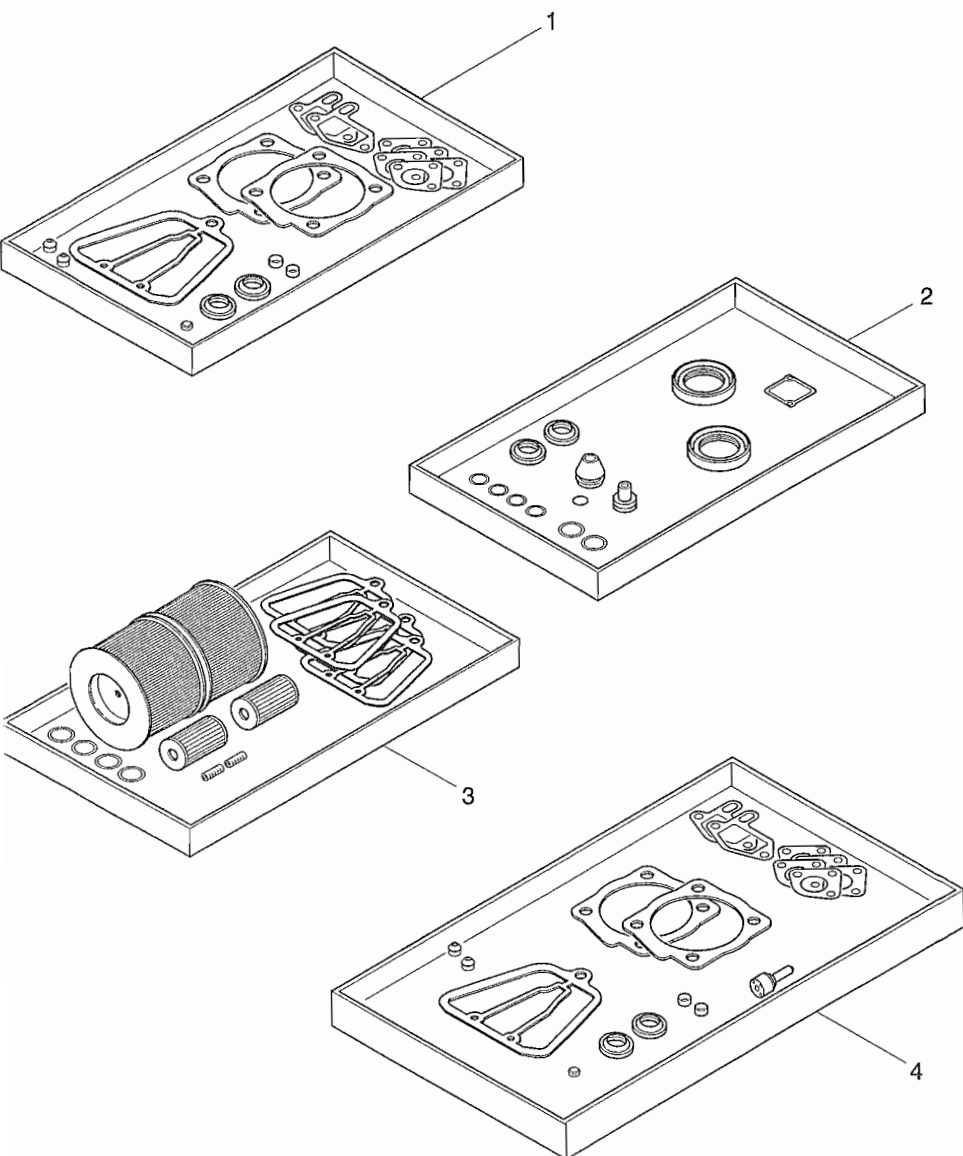

Fig.-No.	HATZ Ident-No.	Stück Qty.	P / W d / D	Bemerkungen Notes
		1B40		
				<p>W: Im Wartungssatz enthalten. Incl. in maintenance kit. Contenu dans le jeu d'entretien. Incluido en el juego de mantenimiento. Contenuto nella serie manutenzione.</p> <p>d: Im Dichtungssatz f. 1 Zyl.-Kopf enthalten. Incl. in gasket set f. 1 cyl. head. Contenu dans le jeu de joint p. 1 culasse. Incluido en el juego de juntas p. 1 culata. Contenuto nella serie guarnizioni p. 1 testa.</p>
				<p>P: Im Pannensatz enthalten. Incl. in emergency kit. Contenu dans le jeu secour. Incluido en el juego para averias. Contenuto nella serie di prima necessità.</p> <p>D: Im Dichtungssatz Kurbelgeh. Incl. in gasket set crankcase. Contenu dans le jeu de joints carter moteur. Incluido en el juego de juntas caja cigueñal. Contenuto nella serie guarnizioni basamento.</p> <p>1: Anzahl pro Satz - Qty. per kit Quantite p. jeu - Cantidad p. juego. Quantità per serie</p>
1	016 792 00	1	P 1	Dichtungssatz für 1 Zylinderkopf Gasket set for 1 cyl. head Jeu de joint p. 1 culasse Juego de juntas para 1 culata Serie guarniziono per 1 testa
2	016 793 00	1		Dichtungssatz für Kurbelgehäuse Gasket set for crankcase Jeu de joints p. carter moteur Juego de juntas para caja cigueñal Serie guarnizioni basamento
3	016 794 00	1		Wartungssatz für 1000 h 1000 hours maintenance kit Kit d'entretien 1000 heures - Juego de piezas para servicio 1000 horas Kit di manutenzione a 1000 ore
4	016 795 00	1		Pannensatz - Emergency kit Kit de secours - Juego para averias Kit di prima necessità



M 34

Zubehör  
Accessoires  
Accessoires  
Accessorios  
Kit accessori

Tafel Nr.  
Tabl. No.  
Tavola N.

02

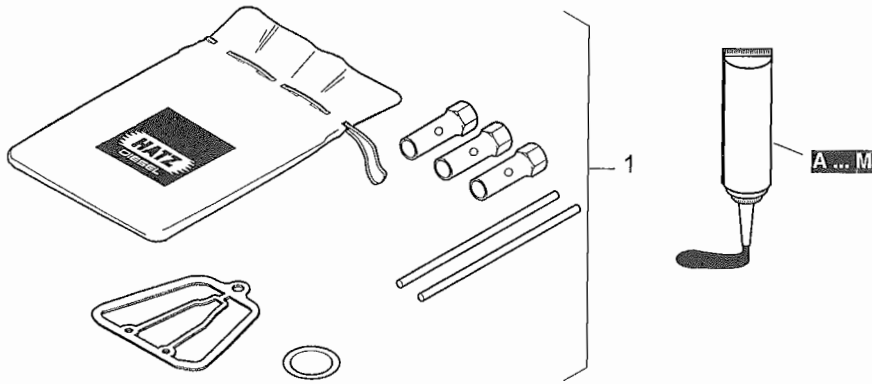

IN  
0,1 mm  
0.004 "

**HATZ DIESEL**

WARTUNG - MAINTENANCE  
ENTRETEN - MANTENIMIENTO  
MANUTENZIONE

8-15 250  
STUNDEN - HEURES - HEURES  
HORAS - ORE

500

BEI BEDARF  
IF NECESSARY  
EN CAS DE  
NECESSIDAD  
SE NECESSARIA

**1B40**

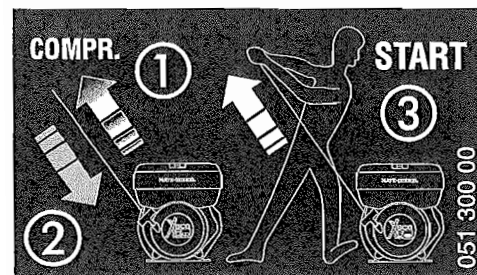

Fig.-No.	HATZ Ident-No.	Stück Qty.	P / W d / D	Bemerkungen Notes
		1B40		
1	013 297 00	1		Zubehörsatz - Accessoires kit Sort. accessoires Juego de accesorios Serie accessorie
2	051 632 01	1		160 x 67 mm
3	051 300 00	1		
4	051 301 00	1		

Dicht- und Klebstoffe  
Sealing- and bonding adhesives  
Etanchéifiant et Colle

Materias para empaquetar y pegar  
Adesivi e collanti

A = 502 230 01	Loctite Activator N	500 ml	} siehe Hinweis auf den einzelnen Bildtafeln  } as specified in the individual tables  } suivant les remarques sur les tableau correspondant  } según las indicaciones de las tablas correspondientes  } seguire le indicazioni sul quadro corrispondente
B = 502 231 00	Loctite 573	50 ml	
C = 502 232 00	Loctite 601	50 ml	
D = 502 233 00	Loctite 221	50 ml	
E = 502 234 00	Loctite 648	10 ml	
F = 502 238 00	Technicoll 8058	0,75 kg	
+ 502 239 00	Technicoll 8367	0,75 kg	
G = 502 565 01	Loctite IS 407	20 g	
H = 502 825 01	Silicon	30 ml	
J = 502 830 03	Hochtemp. Paste	100 ml	
K = 503 426 00	Hochtemp. Fett	100 g	
L = 502 566 00	Silicon sealer	100 g	
M = 504 851 00	Schleifpaste	80 g	

M 01

Kurbelgehäuse  
Crankcase  
Carter moteur  
Caja cigueñal  
Basamento motore

Tafel Nr.  
Tabl. No.  
Tavola N.

03

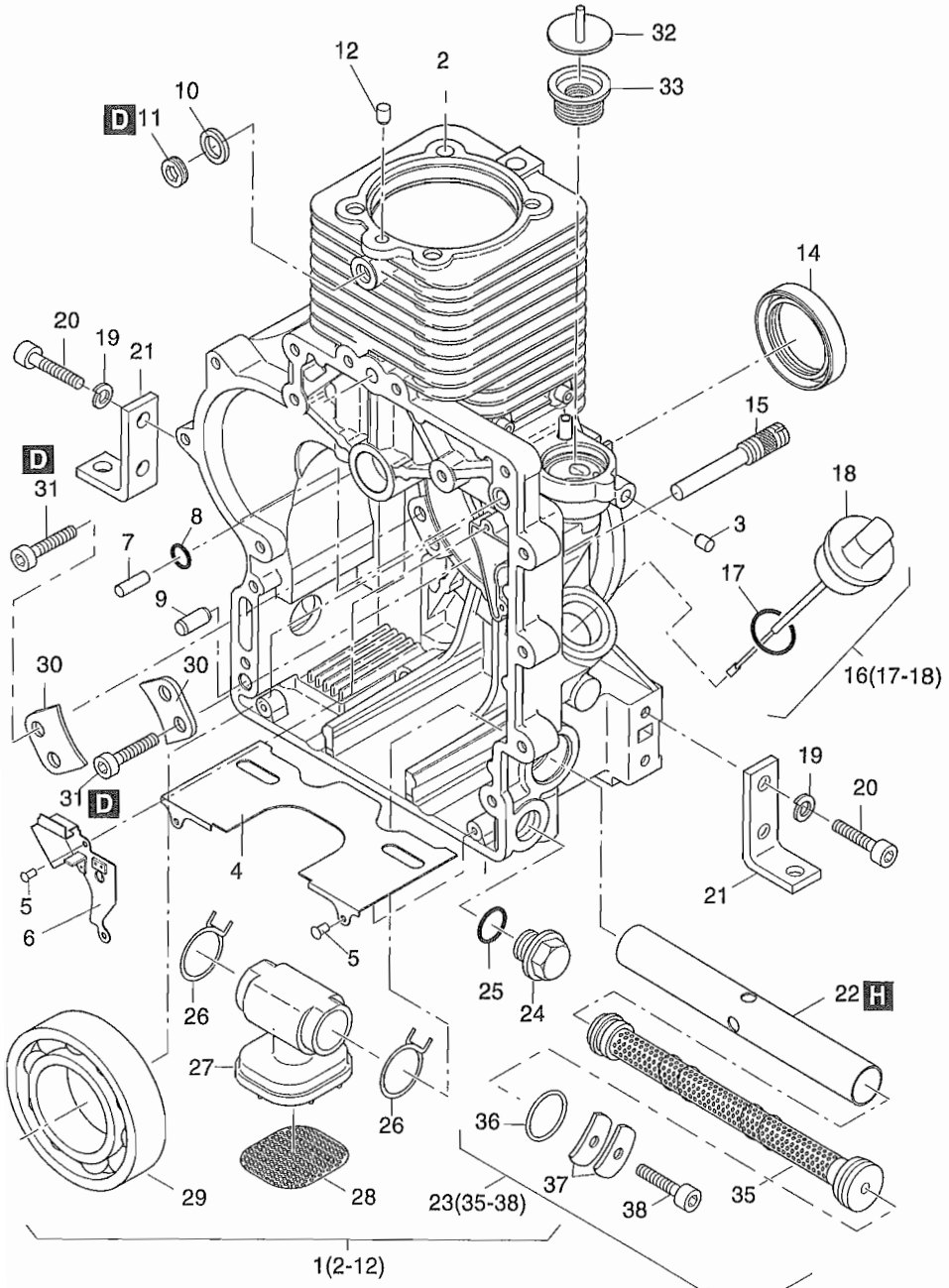

Fig.-No.	HATZ Ident-No.	Stück Qty.	P / W d / D	Bemerkungen Notes
		1B40		
1	01679100	1		
2	-----	-		
3	-----	-		
4	04141600	1		
5	40002600	4		3,2
6	01336400	1		
7	50502800	1		8 M 6 x 24 DIN 6325
8	50440300	1	D1	8 x 1,5
9	50249101	1		8 M 6 x 20 DIN 6325 2-Fasen
10	50062400	1		A 10 x 13,5 DIN 7603 - Cu
11	50062300	1		M 10 x 1 DIN 908 - 5.8 A3C
12	-----	-		
14	50479000	1	D1	45 x 60 x 8
15	04144401	1		
16	01342800	1		
17	04125000	1	D1	26 x 35 x 3
18	-----	-		
19	50208500	8		8 DIN 128 A3C
20	50177500	8		M 8 x 40 DIN 912 - 8.8 A3C
21	04144701	4		
22	04141500	1		
23	01542702	1		
24	50373100	1		AM 22 x 1,5 DIN 7604 A3C magn.
25	50459100	1	D1	A 22 x 27 DIN 7603 - Al
26	05036900	2		
27	04104400	1		
28	04104500	1		
29	50478900	1		6310 C4 DIN 625
30	04133800	3		
31	50143200	6		M 6 x 18 DIN 6912 - 10.9
32	01555800	1		
33	03568700	1		
35	-----	-		
36	50475901	1	D1,W1	20 x 4
37	05148200	2		
38	50170700	1		M 6 x 16 DIN 912 - 8.8 A3C

**M 01**

Massenausgleich  
Compensation of masses  
Equilibrage des masses  
Compensación de las masas  
Masse controrotanti

Tafel Nr.  
Tabl. No.  
Tavola N.

**04**

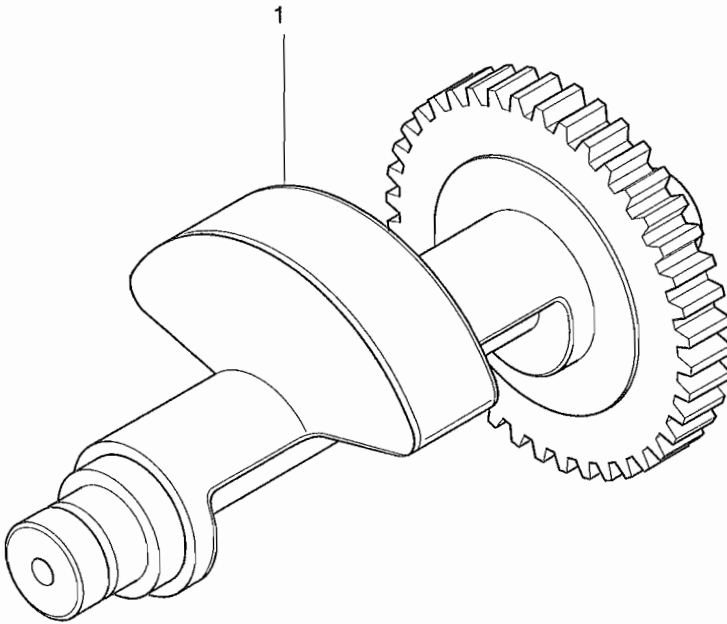

Fig.-No.	HATZ Ident-No.	Stück Qty.	P / W d / D	Bemerkungen Notes
		1B40 . . U		
1	01349201	1		

M 02

Kurbelwelle  
Crankshaft  
Vilebrequin  
Cigüeñal  
Albero a gomito

Tafel Nr.  
Tabl. No.  
Tavola N.

05

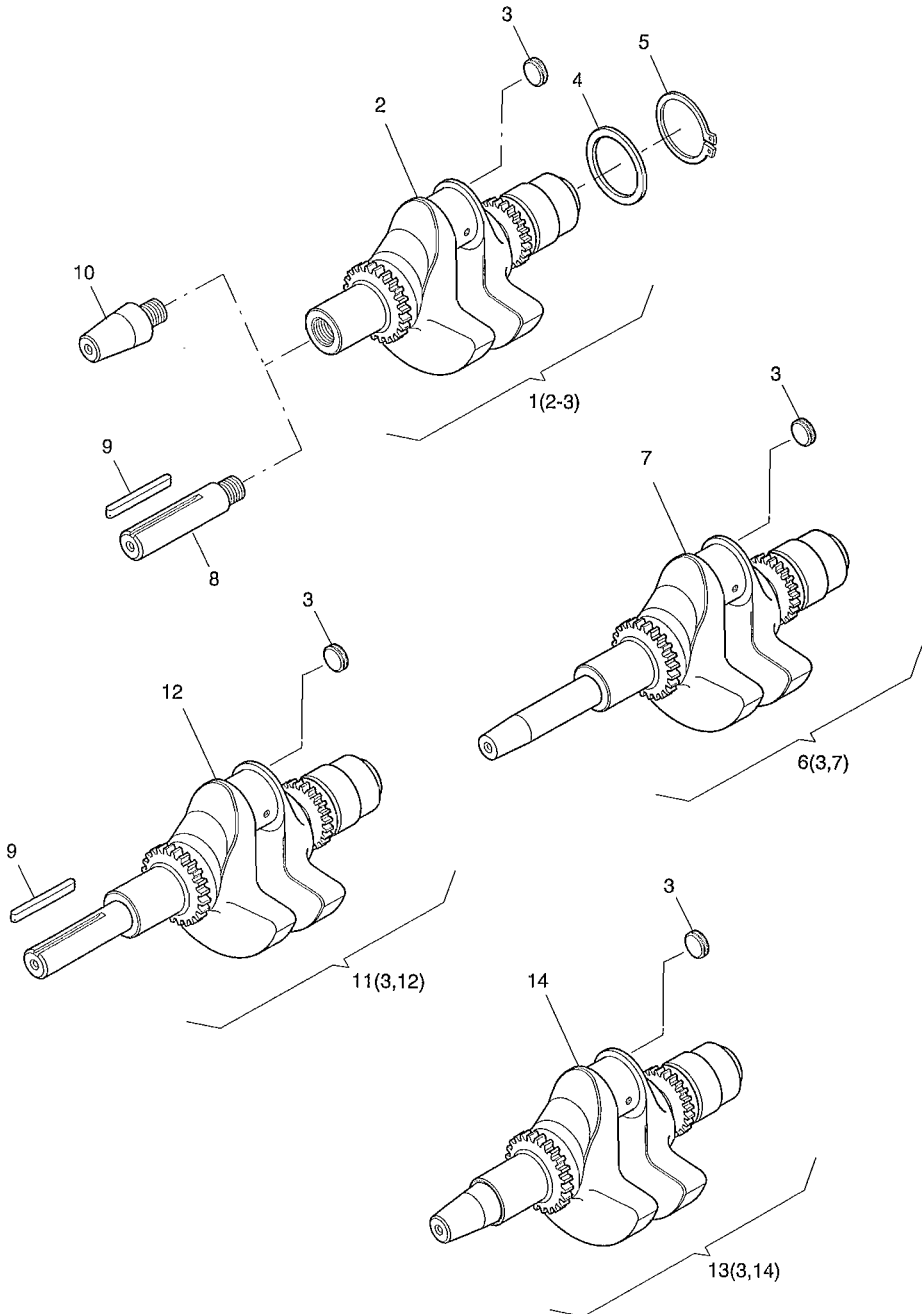

Fig.-No.	HATZ Ident-No.	Stück Qty.	P / W d / D	Bemerkungen Notes
		1B40		
1	01359400	1		"U" Nr.X
2	-----	-		
3	04147300	1		Ø 14mm
4	50481400	1		50 x 62 x 3,0
5	50021800	1		A 50 x 2 DIN 471
6	01349300	1		"U" Nr.4 SAE Ø 7/8"
7	-----	-		
8	05127600	1		Nr. 2 Ø 1" zyl.,cil.
9	05141600	1		A 6,35 x 61
10	05099700	1		Nr. 6 ital. 23keg., con.
11	01359200	1		„U“ Nr.2 Ø 1“ zyl., cyl.
12	-----	-		
13	01359600	1		„U“ Nr.6 ital. 23, keg., con.
14	-----	-		



# M 04

Nockenwelle  
Camshaft  
Arbre à cames  
Arbol de levas  
Albero a camme

Tafel Nr.  
Tabl. No.  
Tavola N.

06

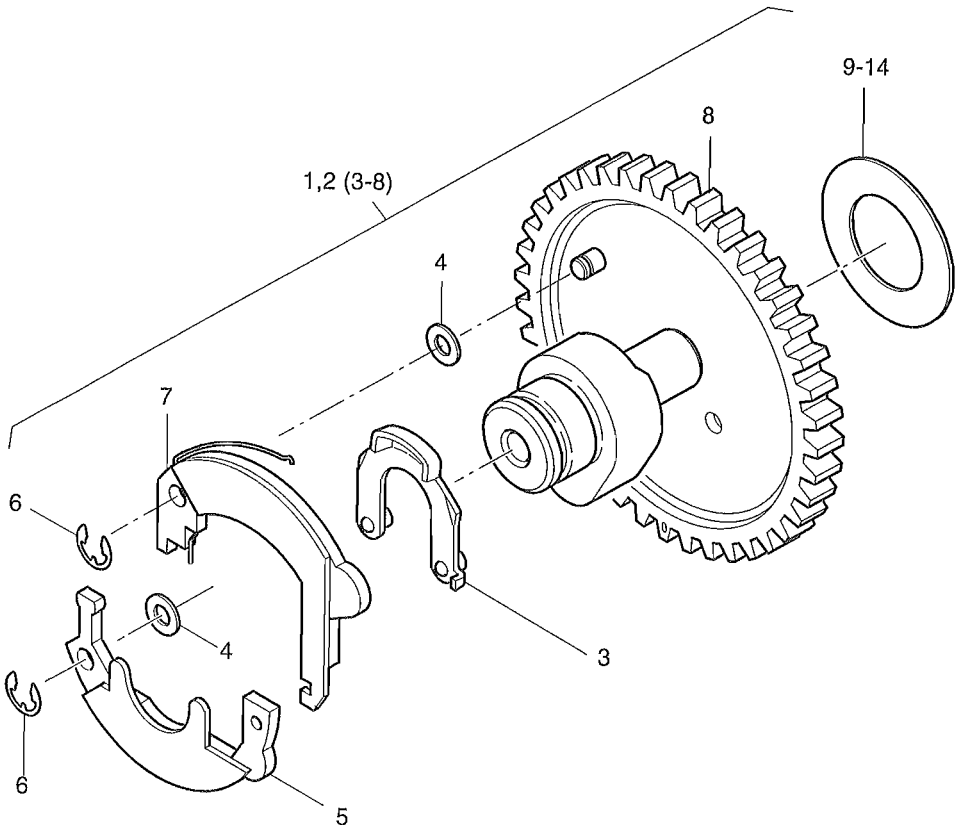

Fig.-No.	HATZ Ident-No.	Stück Qty.	P / W d / D	Bemerkungen Notes
		1B40		
1	01345001	0...1		Handstart
2	01365100	0...1		E-Start
3	01326400	1		
4	50123200	2		5 x 10 x 0,5DIN 988
5	01326600	1		
6	50255300	2		3,2          DIN 6799
7	01326501	0...1		Handstart
7	01364900	0...1		E-Start
8	-----	-		
9	04121700	0...1		0,9 mm 23 x 38 x 0,9
10	04112100	0...1		1,0 mm 23 x 38 x 1,0
11	04112200	0...1		1,1 mm 23 x 38 x 1,1
12	04112300	0...1		1,2 mm 23 x 38 x 1,2
13	04125100	0...1		1,3 mm 23 x 38 x 1,3
14	04125200	0.. 1		1,4 mm 23 x 38 x 1,4

**M 05**

Kolben, Pleuel  
Piston, Conrod  
Piston, bielle  
Embolo, biela  
Pistone, biella

**M 06**

Zylinder  
Cylinder  
Cylindre  
Cilindro  
Cilindro

Tafel Nr.  
Tabl. No.  
Tavola N.

**07**

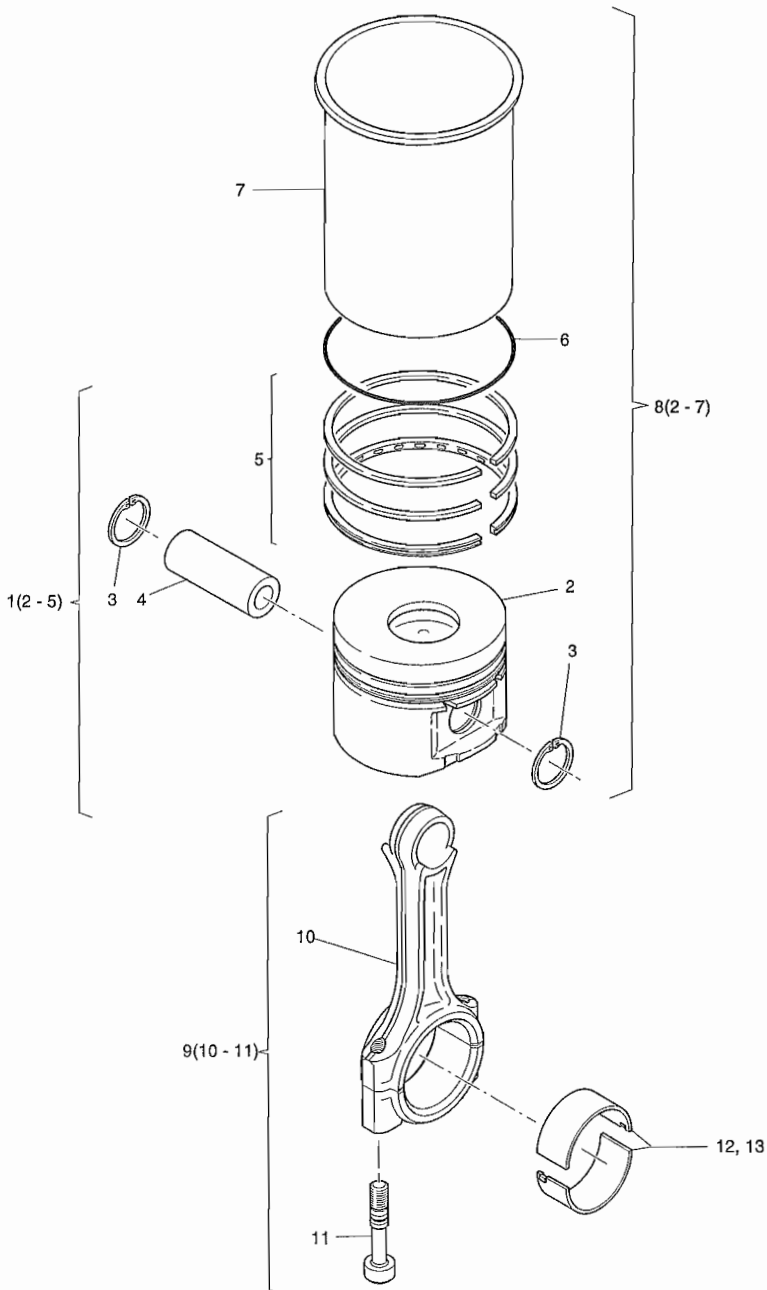

Fig.-No.	HATZ Ident-No.	Stück Qty.	P / W d / D	Bemerkungen Notes
		1B40		
1	01346101	1		88 mm
2	-----	-		
3	50482300	2		
4	-----	-		
5	01346201	1		
6	50479301	1		93 x 1,5
7	-----	-		
8	01679600	1		
9	01343500	1		
10	-----	-		
11	04100500	2		
12	01679800	1		
13	01692700	1		- 0,5 mm

M 07

Zylinderkopf  
Cylinder head  
Culasse  
Culata  
Testa

Tafel Nr.  
Tabl. No.  
Tavola N.

08

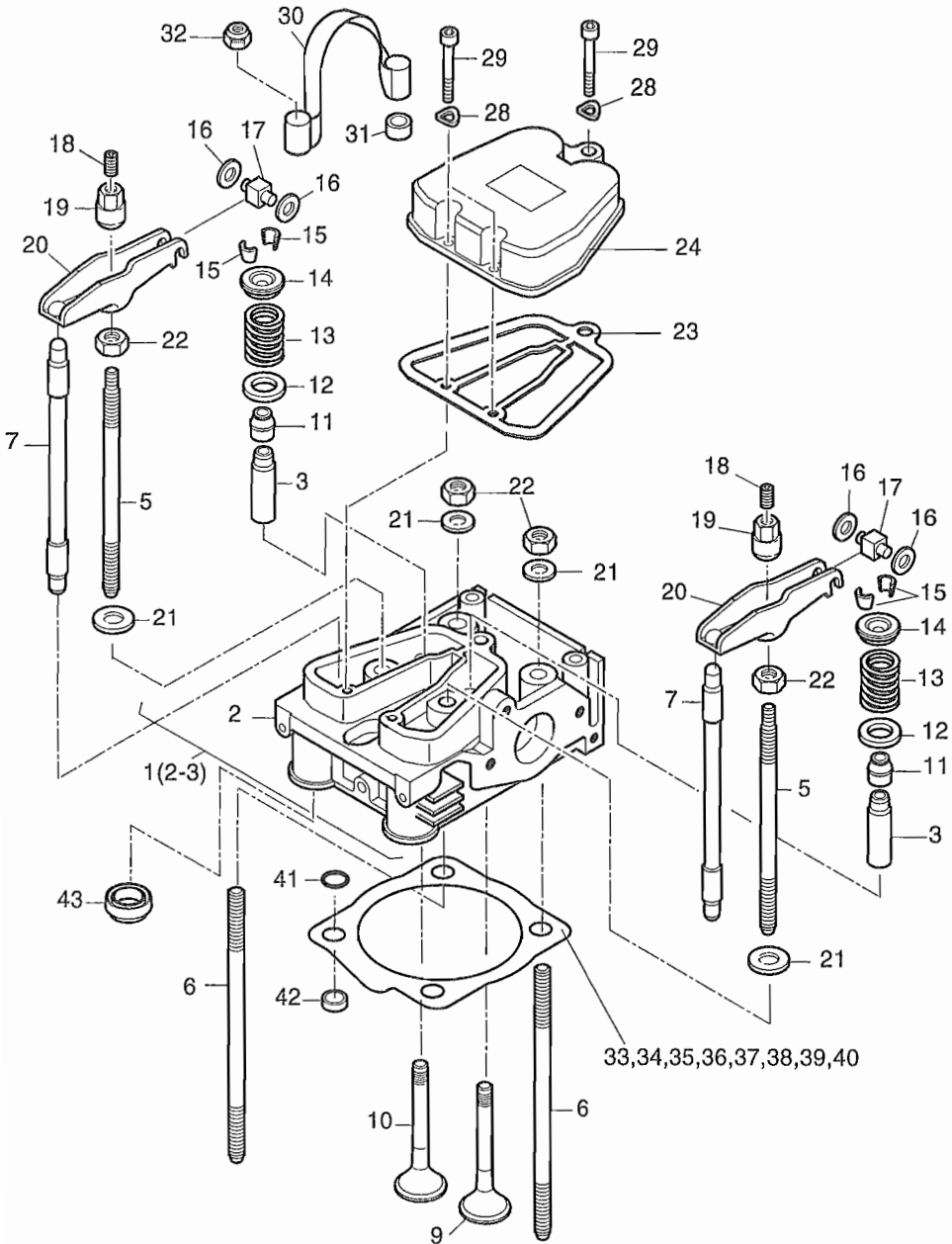

Fig.-No.	HATZ Ident-No.	Stück Qty.	P / W d / D	Bemerkungen Notes
		1B40		
1	01596102	1		
2	-----	-		
3	05209700	2		
5	05159600	2		149 (M 10 - M 8)
6	05159700	2		155 (M 10)
7	01359900	2		
9	05145100	1		
10	05145200	1		
11	50425800	2	d2	
12	04147100	2		
13	04146900	2		
14	04147000	2		
15	50425700	2		
16	50445100	4		
17	05091101	2		
18	50513100	2	W2	M 8 x 10 DIN 916 - 45 H
19	05054700	2		
20	05146700	2		
21	05099300	4		10,1 x 24 x 3
22	50396600	4		M 10 DIN 934 - 10 A3C
23	05156401	1	d1,W4	
24	05146501	1		
28	50081200	3		A 6 DIN 137 A3C
29	50374900	3		M 6 x 35 DIN 912 - 8.8 A3C
30	04117701	1		
31	04126100	2		10 x 12 x 9
32	40028600	2		VM 10 DIN 980 - 8 C3A
33	05158802	0...1		0,3 mm
34	05158902	0...1		0,4 mm
35	05159002	0...1	d1	0,5 mm
36	05159102	0...1	d1	0,6 mm
37	05159202	0...1		0,7 mm
38	05159302	0...1		0,8 mm
39	05159402	0...1		0,9 mm
40	05159502	0...1		1,0 mm
41	50503100	2	d2	8 x 15
42	04174500	2		
43	04106500	2	d2	

M 10

Ölpumpe, Regler  
Oil pump, governor  
Pompe à huile, régulateur  
Bomba de aceite, regulador  
Pompa olio, regolatore

M 32

Drehzahlverstellung  
Speed control  
Réglage régime  
Ajuste de revoluc.  
Regolatore di giri

Tafel Nr.  
Tabl. No.  
Tavola N.

09

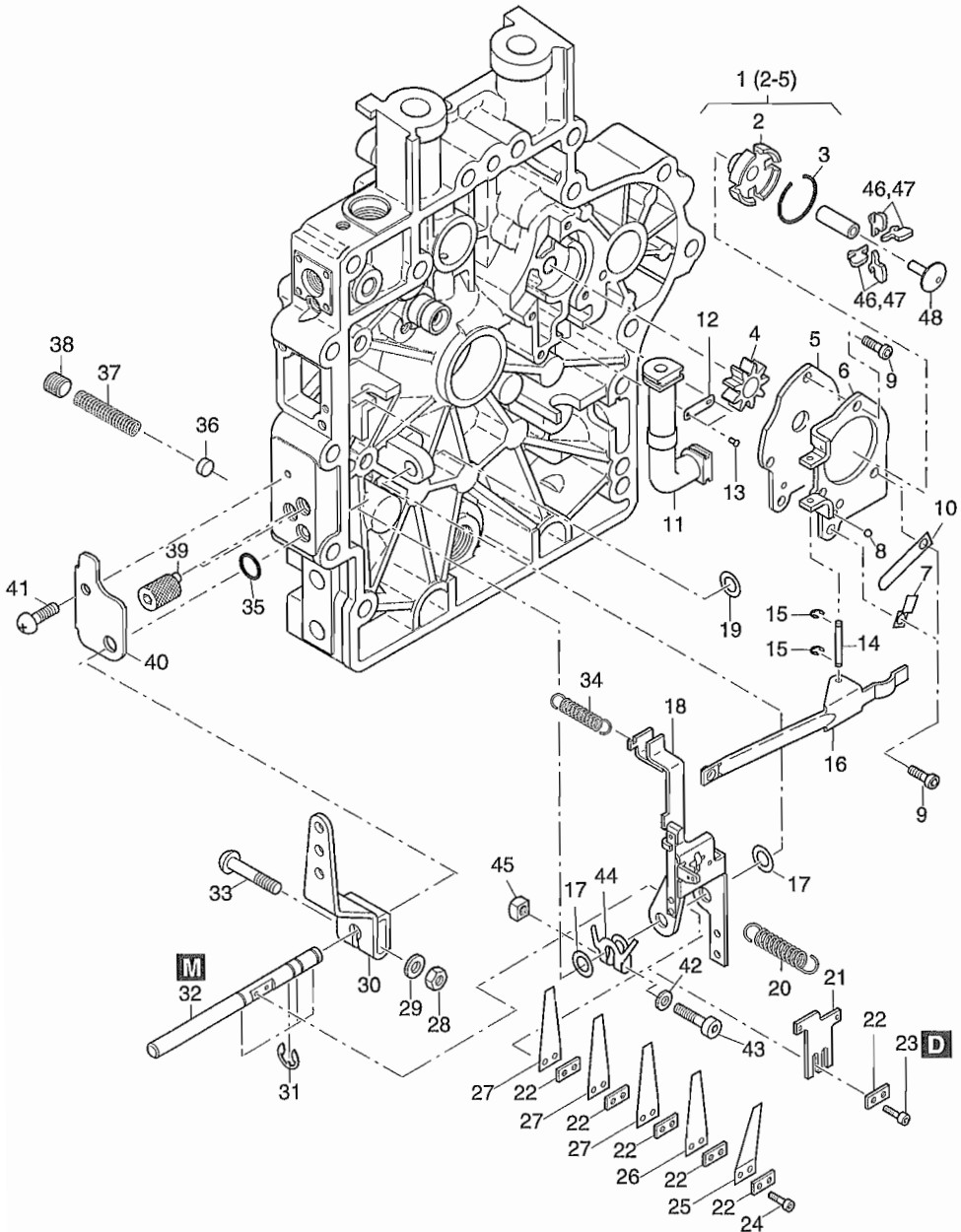

Fig.-No.	HATZ Ident-No.	Stück Qty.	P / W d / D	Bemerkungen Notes
		1B40		
1	01344501	1		
2	-----	-		
3	50434901	1		RB 25      DIN 7993
4	-----	-		
5	-----	-		
6	04148400	1		
7	05097100	1		
8	50447900	1		3,5 mm Kl. III
9	50429400	4		M 5 x 12    DIN 6912 - 8.8
10	05097300	1		0,4 mm
11	01346000	1		
12	04153400	1		
13	40002600	2		3,2
14	05078600	1		
15	50434800	2		1,9            DIN 6799
16	01345901	1		
17	50422400	2		8 x 14 x 1,0 DIN 988
18	01365200	1		
19	50125800	1		8 x 14 x 0,5 DIN 988
20	05130900	1		
21	05130800	1		
22	05079800	1...5		
23	50465300	2		M 3 x 8      DIN 912 - 8.8
24	50435000	2		M 3 x 12    DIN 912 - 8.8
25	05148600	1		0,4 mm 19° ∠ } Gen. - PV 78 0,3 mm            } 95138500 0,2 mm            }
26	05078900	1		
27	05131600	1...3		
28	50144400	1		M 6            DIN 934 - 8 A3C
29	50144500	1		6,4            DIN 125 - St A3C
30	04095600	1		
31	50092700	4		7              DIN 6799 A3C
32	05079301	1		
33	03927300	1		M 6 x 32    8 x 2 FPM MOLYKOT.
34	04000200	1		
35	40022401	1	D1	8 x 2
36	05151700	1		



**M 10**

Ölpumpe, Regler  
Oil pump, governor  
Pompe à huile, régulateur  
Bomba de aceite, regulador  
Pompa olio, regolatore

**M 32**

Drehzahlverstellung  
Speed control  
Réglage régime  
Ajuste de revoluc.  
Regolatore di giri

Tafel Nr.  
Tabl. No.  
Tavola N.

**09**

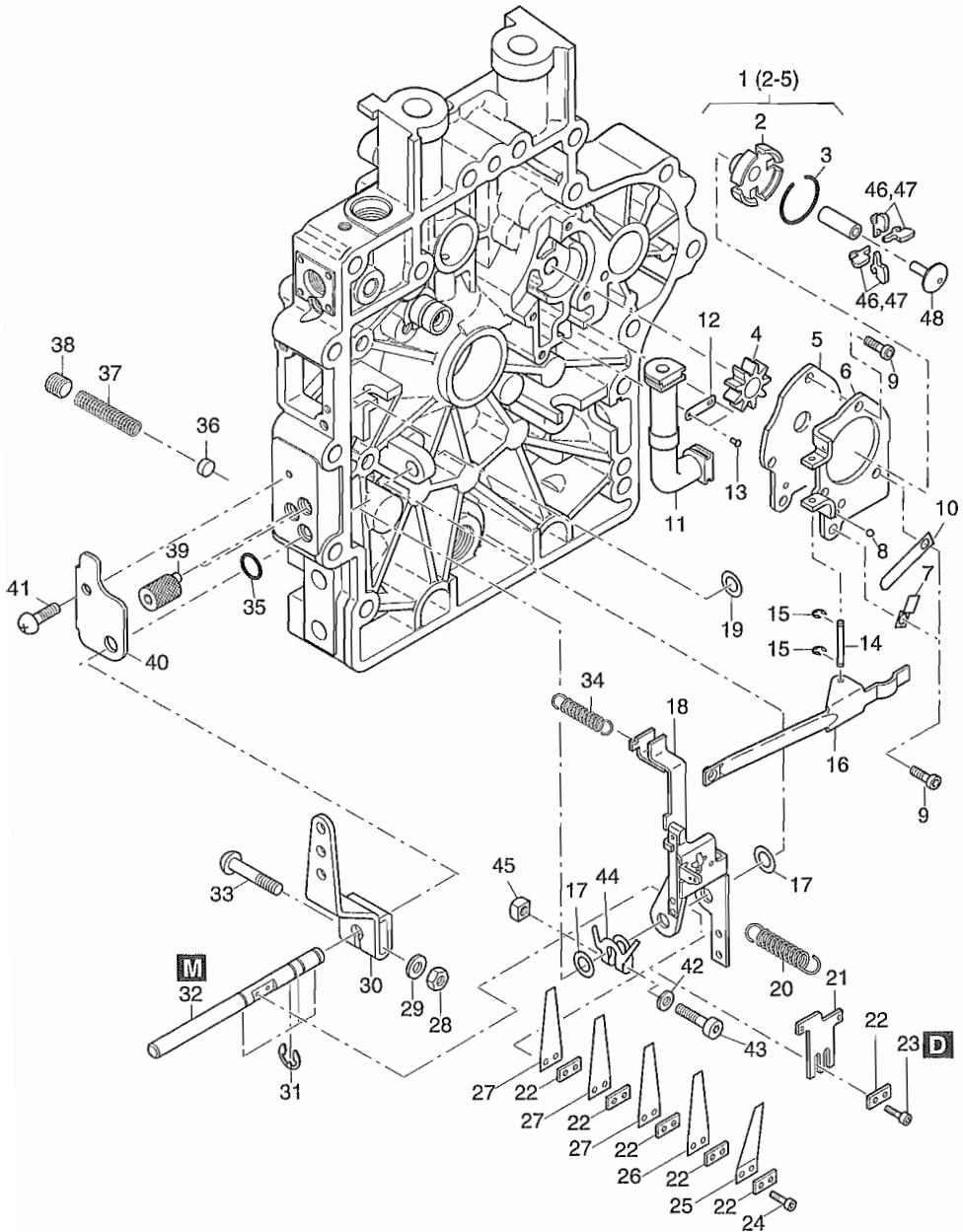

Fig.-No.	HATZ Ident-No.	Stück Qty.	P / W d / D	Bemerkungen Notes
		1B40		
37	50488700	1		
38	50475700	1		M 10 x 10 DIN 913 - A3C TUF.
39	05178800	2		
40	05178400	1		
41	50492300	1		M 5 x 12 ISO 7380 - 10.9 Zn
42	50216300	1		5,3 DIN 125 - St A3C
43	50492200	1		M 5 x 25 DIN 6912 - 8.8
44	05178500	1		
45	50422700	1		M 5 DIN 557-5 A3C
46	05079602	4...8		Gen. - PV 78 = 4
47	05160202	0...4		Gen. - PV 78 = 4
48	05078502	1		

M 11

Steuerdeckel  
Timing cover  
Couvercle distribution  
Tapa de mando  
Coperchio distribuzione

Tafel Nr.  
Tabl. No.  
Tavola N.

10

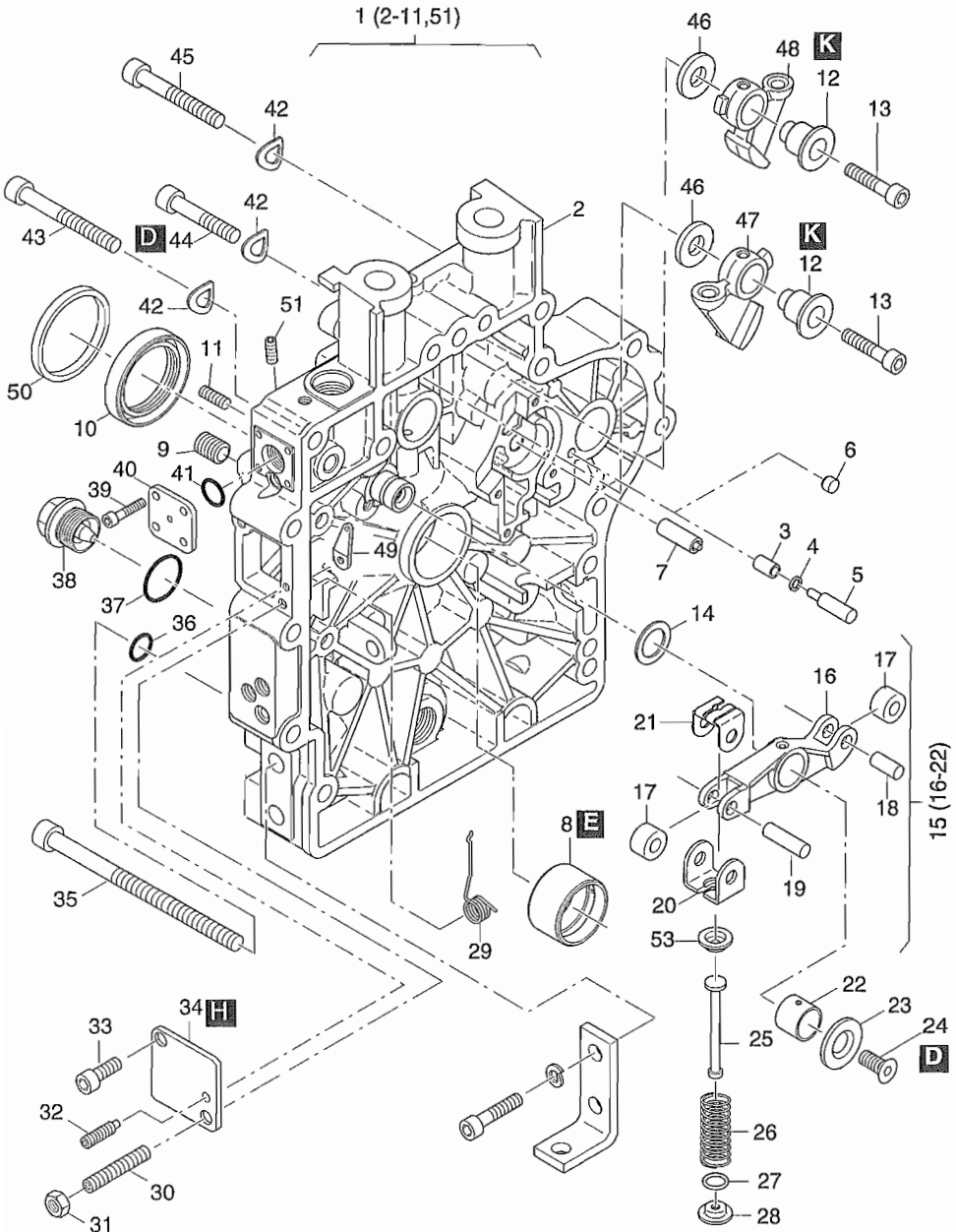

Fig.-No.	HATZ Ident-No.	Stück Qty.	P / W d / D	Bemerkungen Notes
		1B40		
1	01679700	1		
2	-----	-		
3	04185800	1		4 x 9 "T"
4	50464100	1	D1	2 x 1 "T"
5	04185700	1		4 x 15 "T"
6	04168600	1		4,3 "U"
7	01344600	1		
8	04148800	1		
9	50358000	4		M 8 x 10 DIN 913 - A3C Tuf.
10	50479500	1	D1	35 x 47 x 7
11	50400600	2		M 5 x 10 DIN 916 - 45H A3C
12	03794201	2		
13	50469900	2		M 6 x 30 DIN 912 - 10.9
14	50485600	1		13 x 19 x 10
15	01346700	1		
16	-----	-		
17	-----	-		
18	-----	-		
19	-----	-		
20	-----	-		
21	-----	-		
22	04152800	1		
23	04152701	1		
24	50422500	1		M 6 x 12 DIN 7991 - 8.8 A3C
25	04094700	1		
26	04095700	1		
27	04133900	1		10,7 x 16 x 0,5
28	04094802	1		
29	05095210	1		
30	50499300	1		M 6 x 35 DIN 913 - 22H A3C
31	50144400	1		M 6 DIN 934 - 8 A3C
32	50499400	1		M 4 x 25 DIN 915 - 45H
33	50384200	1		M 6 x 12 DIN 912 - 8 A3C TUF.
34	04095210	1		
35	50463000	2		M 8 x 130 DIN 912 - 8.8 A3C

M 11

Steuerdeckel  
Timing cover  
Couvercle distribution  
Tapa de mando  
Coperchio distribuzione

Tafel Nr.  
Tabl. No.  
Tavola N.

10

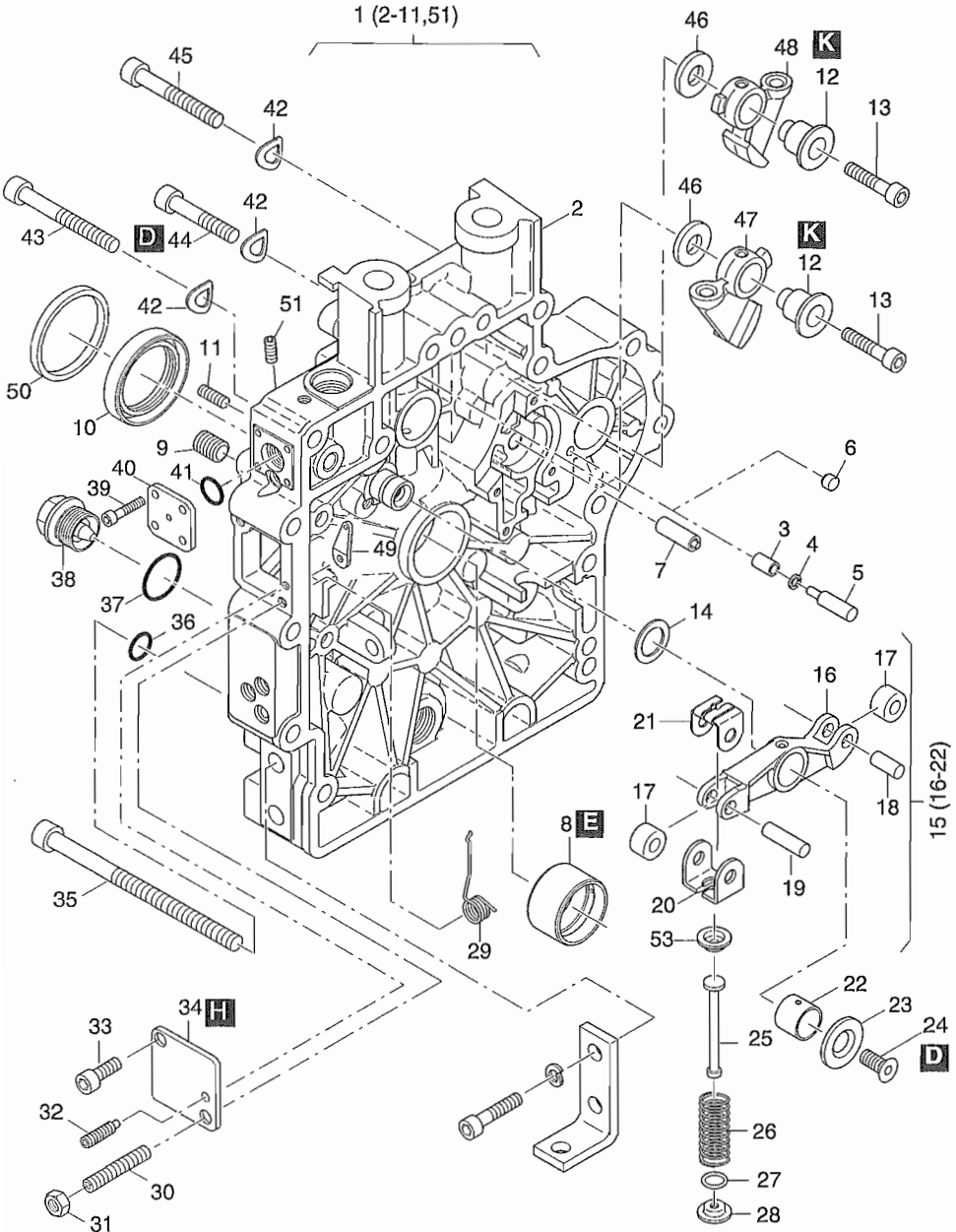

Fig.-No.	HATZ Ident-No.	Stück Qty.	P / W d / D	Bemerkungen Notes
		1B40		
36	50162900	2		A 8 x 14 DIN 7603 - Cu
37	50459100	1	W4, D2	A 22 x 27 DIN 7603 - Al
38	50373100	1	W1	AM 22 x 1,5 DIN 7604 A3C magn.
39	50397100	4		M 4 x 10 DIN 912 - 8.8 A3C TUF.
40	01351700	1		
41	50329000	1	D1	9,5 x 2,5
42	50095100	15		A 8 DIN 137 A3C
43	50288800	11		M 8 x 55 DIN 912 - 8.8 A3C
44	50177500	2		M 8 x 40 DIN 912 - 8.8 A3C
45	50392900	2		M 8 x 50 DIN 912 - 8.8 A3C
46	03794100	2		10,1 x 22 x 3
47	04146600	1		
48	04146000	1		
49	05127100	1		
50	04097800	1		SAE A (Zentrierring)
51	50262400	1		M 6 x 10 DIN 916 - TUF. 360
53	04189500	1		

**M 13**

Gebläse  
Blower  
Soufflerie  
Ventilador  
Ventilatore

**M 17**

Schwungrad  
Flywheel  
Volant  
Volante  
Volano

Tafel Nr.  
Tabl. No.  
Tavola N.

**11**

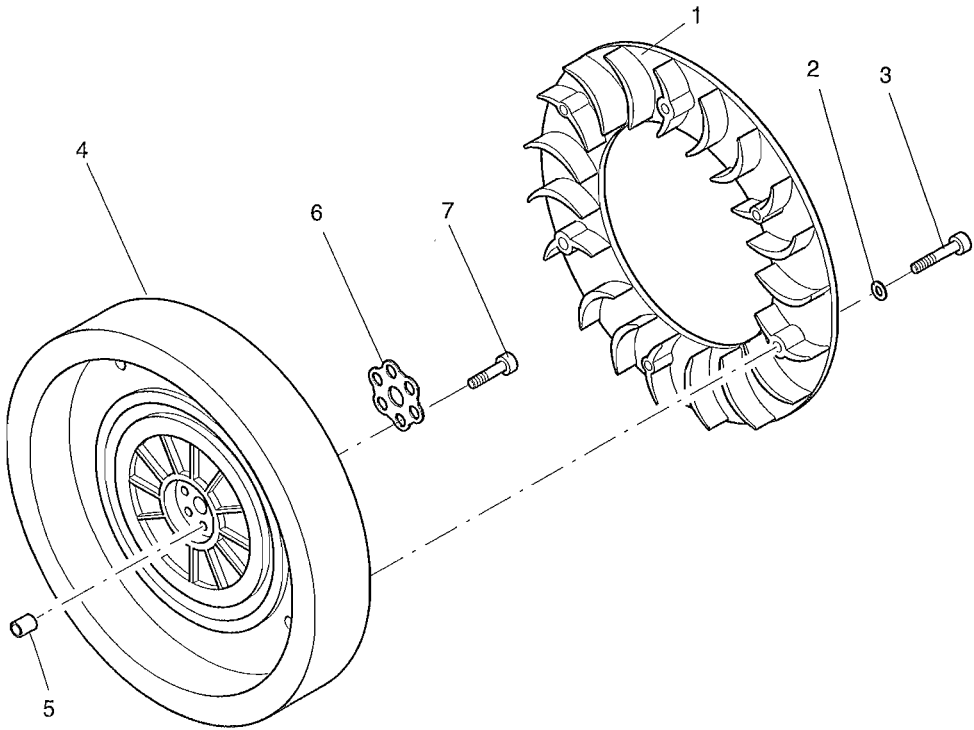

Fig.-No.	HATZ Ident-No.	Stück Qty.	P / W d / D	Bemerkungen Notes
		1B40		
1	01347501	1		
2	50003400	6		A 4      DIN 137
3	50327300	6		M 4 x 20    DIN 912 - 8.8 A3C
4	04153901	1		Handstart
5	50205600	1		10 x 12    DIN 7346 55 SI 7
6	04155101	1		
7	50502500	6		M 8 x 35    DIN 912 - 12.9 A3C



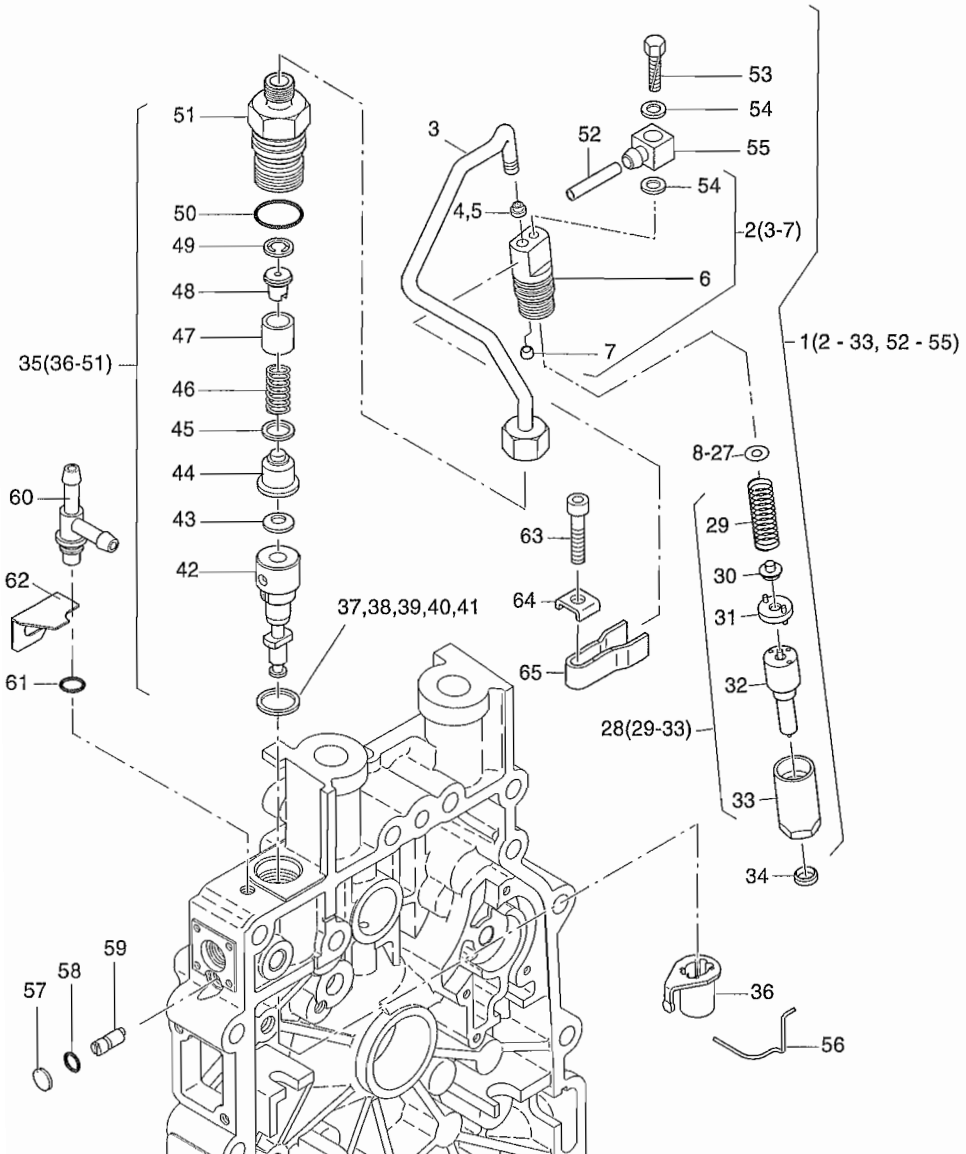

Fig.-No.	HATZ Ident-No.	Stück Qty.	P / W d / D	Bemerkungen Notes
		1B40		
1	01622800	1		
2	01680600	1		
3	-----	-		
4	05096101	0...1		4,9 mm
5	05070601	0...1		5,3 mm
6	-----	-		
7	05081500	0...1		BOSCH
8	50436400	0...1		1,00 mm
9	50436500	0...1		1,04 mm
10	50436600	0...1		1,10 mm
11	50436700	0...1		1,14 mm
12	50436800	0...1		1,20 mm
13	50436900	0...1		1,24 mm
14	50437000	0...1		1,30 mm
15	50437100	0...1		1,34 mm
16	50437200	0...1		1,40 mm
17	50437300	0...1		1,44 mm
18	50437400	0...1		1,50 mm
19	50437500	0...1		1,54 mm
20	50437600	0...1		1,60 mm
21	50437700	0...1		1,64 mm
22	50437800	0...1		1,70 mm
23	50437900	0...1		1,74 mm
24	50438000	0...1		1,80 mm
25	50438100	0...1		1,84 mm
26	50438200	0...1		1,90 mm
27	50438300	0...1		1,94 mm
28	01347400	1		
29	-----	-		
30	-----	-		
31	-----	-		
32	50501200	1	P1	
33	-----	-		
34	05070500	1	d1	
35	01680800	1		
36	01330801	1		

} s. 95125801

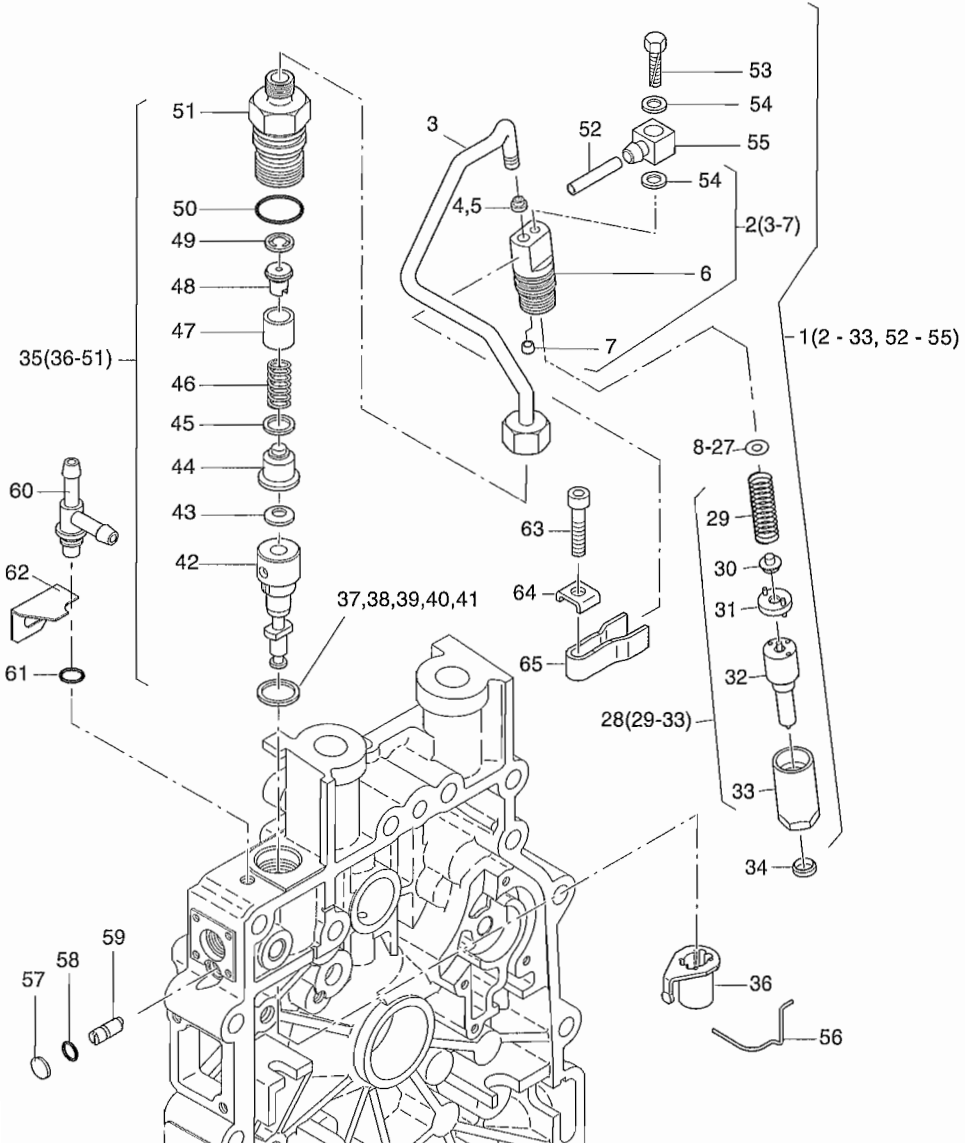

Fig.-No.	HATZ Ident-No.	Stück Qty.	P / W d / D	Bemerkungen Notes
		1B40		
37	04096300	0...1		0,2 mm
38	04096400	0...1		0,3 mm
39	04096500	0...1		0,4 mm
40	04096600	0...1		0,5 mm
41	04096700	0...1		0,6 mm
42	-----	-		
43	04165200	1		8
44	-----	-		
45	50476900	1		9,5 x 13 x 0,5
46	-----	-		
47	05181000	1		9,2 x 12,8
48	05180900	1		
49	05180800	1		
50	50489200	1		17 x 2
51	05181100	1		
52	05215000	1		2,5 x 195
53	50464500	1		AM 4 x 16 DIN 7315
54	50110800	2		A 4 x 8 DIN 7603 - Cu
55	05129000	1		
56	04161800	1		
57	50476000	1		8 DIN 470 Al
58	50330100	1		4 x 1,2
59	04097710	1		
60	05183000	1		
61	50154300	1	D1	7,5 x 1,5
62	05183100	1		
63	50323900	1		M 6 x 30 DIN 912 - 8.8 A3C
64	05089300	1		6,4
65	05056700	1		

Reversierstarter  
Recoil starter  
Demarreur reversible  
Arrancador reversible  
Avviamento a strappo

**M 15**

Tafel Nr.  
Tabl. No.  
Tavola N.

**13**

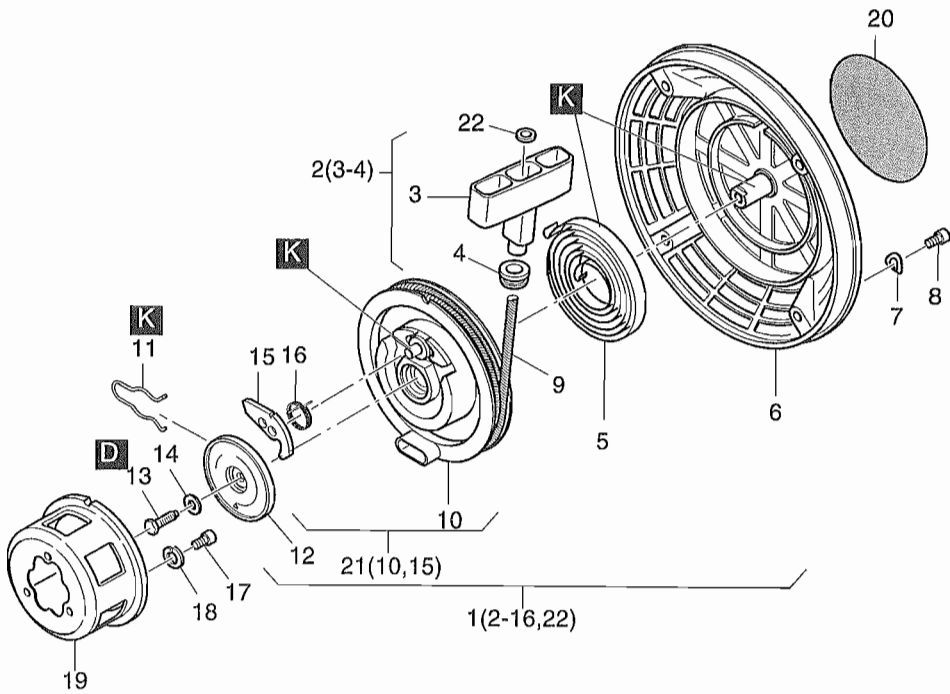

Fig.-No.	HATZ Ident-No.	Stück Qty.	P / W d / D	Bemerkungen Notes
		1B40		
1	01515002	1		
2	01497800	1		
3	-----	-		
4	03665200	1		
5	05045201	1		
6	01569300	1		
7	50081200	4		A 6      DIN 137 A3C
8	50062700	4		M 6 x 10   DIN 912 - 8.8 A3C
9	05088901	1		1750 mm
10	-----	-		
11	05044901	1		
12	05045001	1		
13	50146300	1		M 6 x 18   DIN 933 - 8.8 A3C
14	50165600	1		6,5 x 14   DIN 6904 - A3C
15	05044800	1		
16	05061300	1		
17	50062700	3		M 6 x 10   DIN 912 - 8.8 A3C
18	50170900	3		6           DIN 128 A3C
19	04155000	1		
20	05109100	1		
21	01548800	1		
22	50514600	1		5,3        DIN 9021   PA 6.6

M 26

Luftführung  
Air duction  
Carter ventilation  
Conducción de aire  
Carter ventilatore

Tafel Nr.  
Tabl. No.  
Tavola N.

14

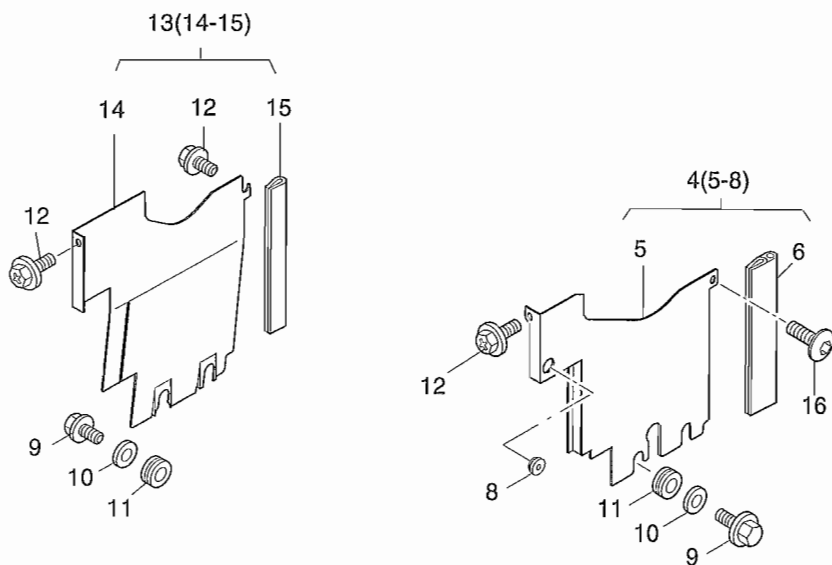
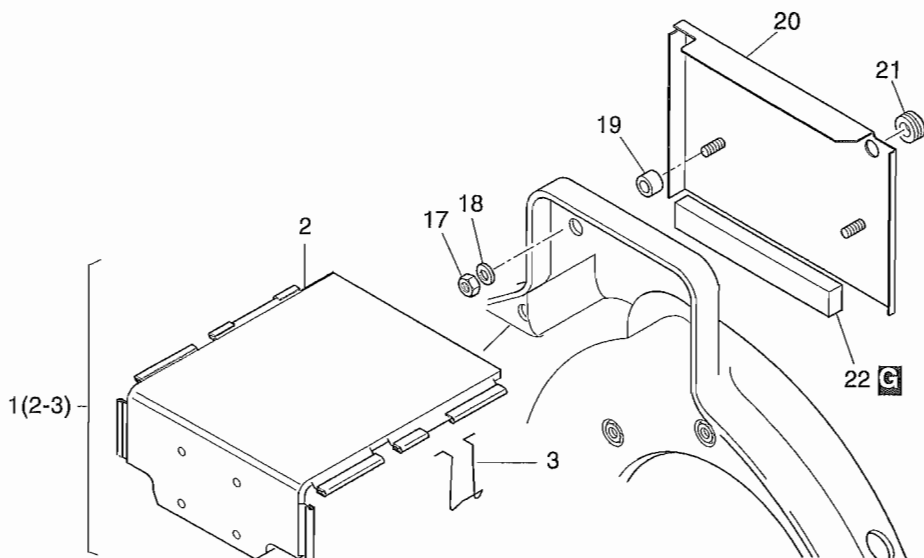

Fig.-No.	HATZ Ident-No.	Stück Qty.	P / W d / D	Bemerkungen Notes
		1B40		
1	01610400	1		
2	-----	-		
3	05152100	1		
4	01345400	1		
5	-----	-		
6	04144200	1		93 mm
8	50334800	1		
9	50445400	4		M 4 x 10
10	50441600	4		4,3      DIN 9021 - A3C 140VH
11	50163801	4		
12	50335600	3		M 6 x 16    KZ1 8.8 A3D
13	01345300	1		
14	-----	-		
15	04144200	1		93 mm
16	50495000	1		M 6 x 12    DIN 7380 - 10.9 A3C
17	50144400	2		M 6          DIN 934 - 8 A3C
18	50170900	2		6            DIN 128 - A3C
19	03354600	2		7 x 12 x 8
20	01698200	1		
21	50334800	1		
22	03577200	1		14 x 9 x 125



Luftführung  
 Air duction  
 Carter ventilation  
 Conducción de aire  
 Carter ventilatore

Tafel Nr.  
 Tabl. No.  
 Tavola N.

M 26

15

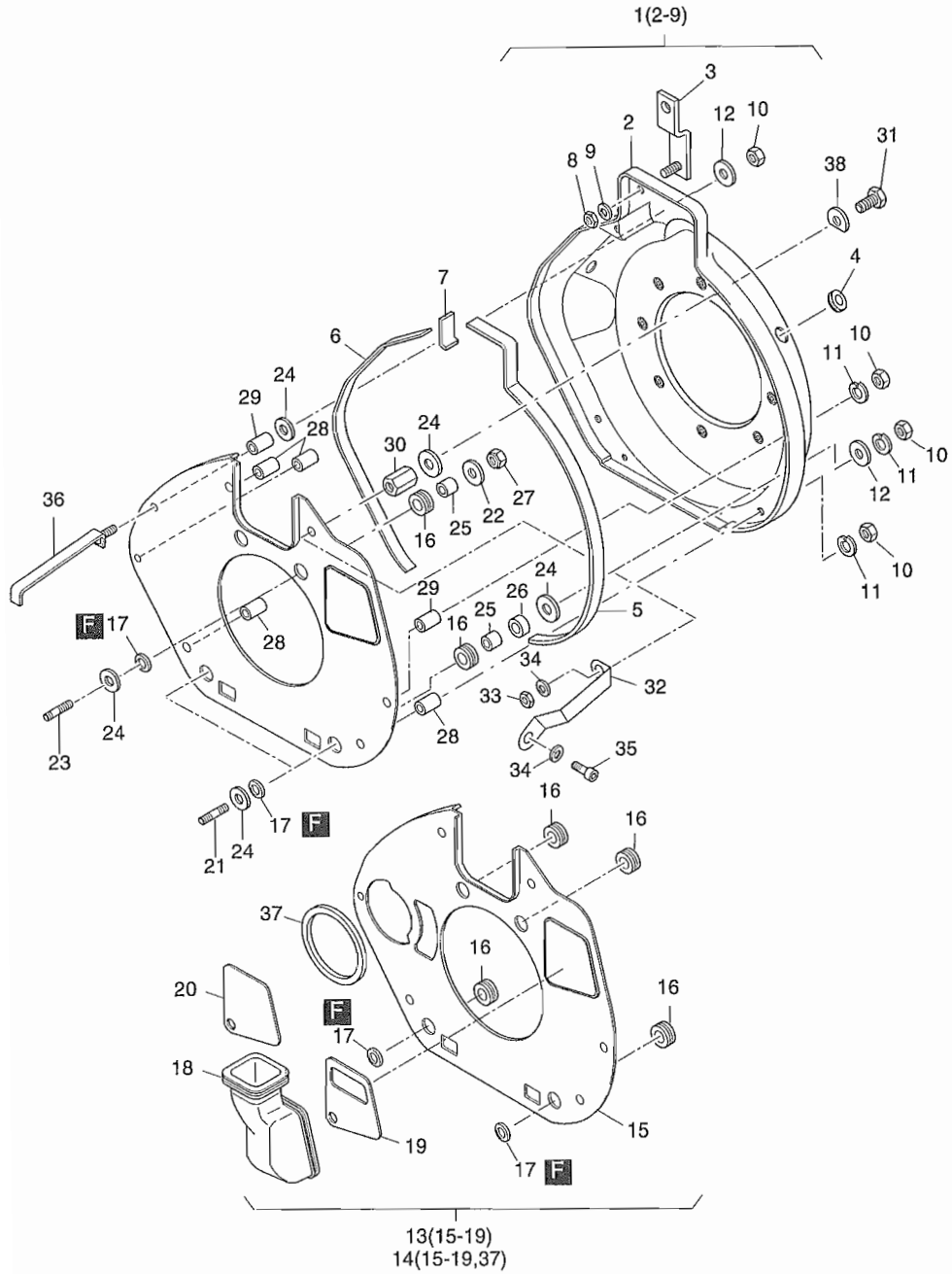

Fig.-No.	HATZ Ident-No.	Stück Qty.	P / W d / D	Bemerkungen Notes
		1B40		
1	01668910	1		
2	-----	-		
3	01331300	2		
4	50453300	1		
5	05189400	1		655 mm
6	05189300	1		520 mm
7	05007300	1		48 mm
8	50144400	2	M 6	DIN 934 - 8 A3C
9	50170900	2	6	DIN 128 A3C
10	50144400	7	M 6	DIN 934 - 8 A3C
11	50170900	8	6	DIN 128 A3C
12	50120000	3	A 6,4	DIN 9021 St A3C
13	01661900	1		Handstart
14	01347600	1		E-Start
15	-----	-		
16	00921400	4		
17	03575500	4		
18	04146800	1		
19	04150700	0...1		
20	04150800	0...1		
21	50458100	2	M 6 x 45	DIN 835 - 8.8 A3C
22	50114300	2	6,4	DIN 7349 A3C
23	50464401	2	M 6 Fo x 35	DIN 939.8.8 A3C TUF
24	04042000	7		6,5 x 22 x 1
25	04119100	4		6 x 8 x 14
26	05188600	2		7 x 12 x 7
27	50328300	2	VM 6	DIN 980 - 8 A3C
28	04139000	4		6,5 x 12 x 18
29	04098400	2		7 x 12 x 16,3
30	05184000	1		M 6 x 17
31	50026400	1	M 6 x 35	DIN 933 - 8.8 A3C
32	01669400	1		
33	50144400	1	M 6	DIN 934 - 8 A3C
34	50170900	2	6	DIN 128 A3C
35	50170700	1	M 6 x 16	DIN 912 - 8.8 A3C
36	01683300	1		
37	04099500	1		
38	05140900	1		

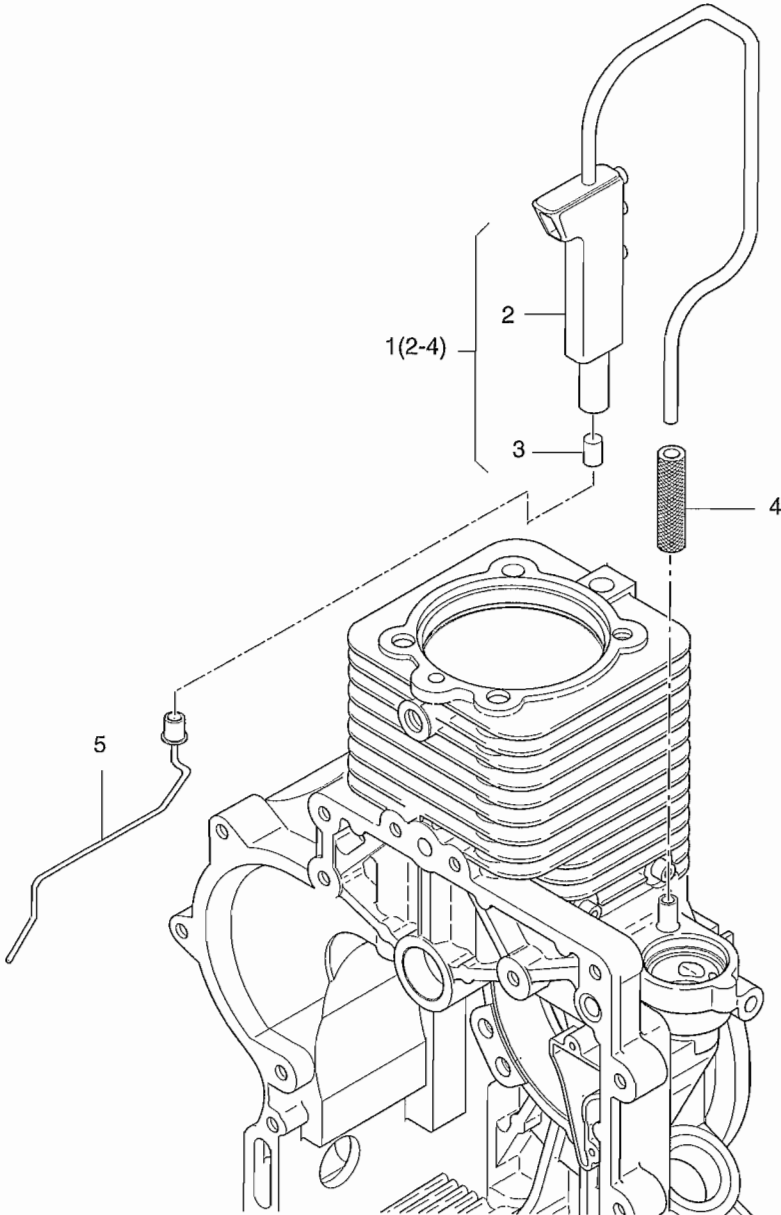

Fig.-No.	HATZ Ident-No.	Stück Qty.	P / W d / D	Bemerkungen Notes
		1B40		
1	01654700	1		
2	-----	-		
3	05102900	1		Filter, Filtre, Filtro
4	05197200	1		7 x 35
5	01626900	1		

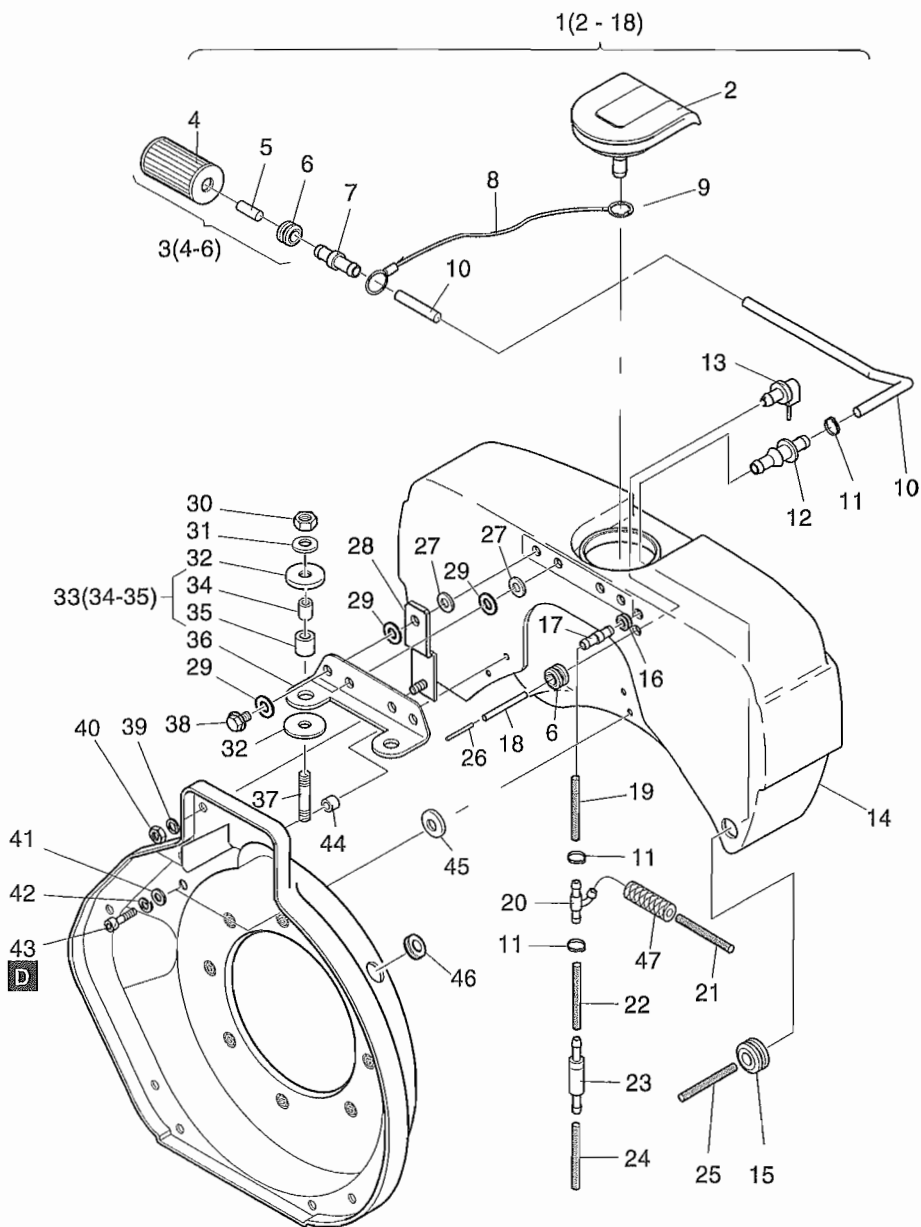

Fig.-No.	HATZ Ident-No.	Stück Qty.	P / W d / D	Bemerkungen Notes
		1B40		
1	01669010	1		
2	01535302	1		
3	01635210	1	W2	
4	-----	-		
5	-----	-		
6	50440901	2		
7	05189000	1		
8	01628900	1		
9	50500800	1		8           DIN 6799
10	05160700	1		3,5 x 340
11	50399801	3	P1	11,3
12	05084010	1		
13	01534900	1		
14	-----	--		
15	50440800	1		
16	05130400	1		
17	05184400	1		
18	05189700	1		1 x 3 x 115
19	05188800	1		4,5 x 120
20	05175601	1		
21	05215000	1		2,5 x 190
22	03664200	1		4,5 x 130
23	01534600	1		
24	05214800	1		4,5 x 40
25	05188700	1		3,5 x 200
26	05190900	1		2 x 0,3 x 24
27	50120000	4		A 6,4       DIN 9021 St A3C
28	01331300	2		
29	05110010	10		7,1 x 17,9 x 2
30	40028400	2		VM 8       DIN 980 - 8 C3A
31	50148100	2		8,4       DIN 125 - St A3C
32	05109810	4		8,2 x 22 x 2
33	01655800	2		
34	-----	-		
35	-----	-		
36	05170110	1		



Fig.-No.	HATZ Ident-No.	Stück Qty.	P / W d / D	Bemerkungen Notes
		1B40		
37	50231900	2		M 8 x 25 DIN 835 - 8.8 A3C
38	01557000	4		M 6 x 18
39	50170900	2		6 DIN 128 A3C
40	50144400	2		M 6 DIN 934 - 8 A3C
41	50120000	4		A 6,4 DIN 9021 St A3C
42	50170900	4		6 DIN 128 A3C
43	50170700	4		M 6 x 16 DIN 912 - 8.8 A3C
44	04118800	2		6,5 x 13 x 4,8
45	04042000	2		6,5 x 22 x 1
46	50453300	1		
47	05213000	1		7 x 25



Luftfilter  
Air filter  
Filtre à air  
Filtro de aire  
Filtro aria

**A 02**

Tafel Nr.  
Tabl. No.  
Tavola N.

**18**

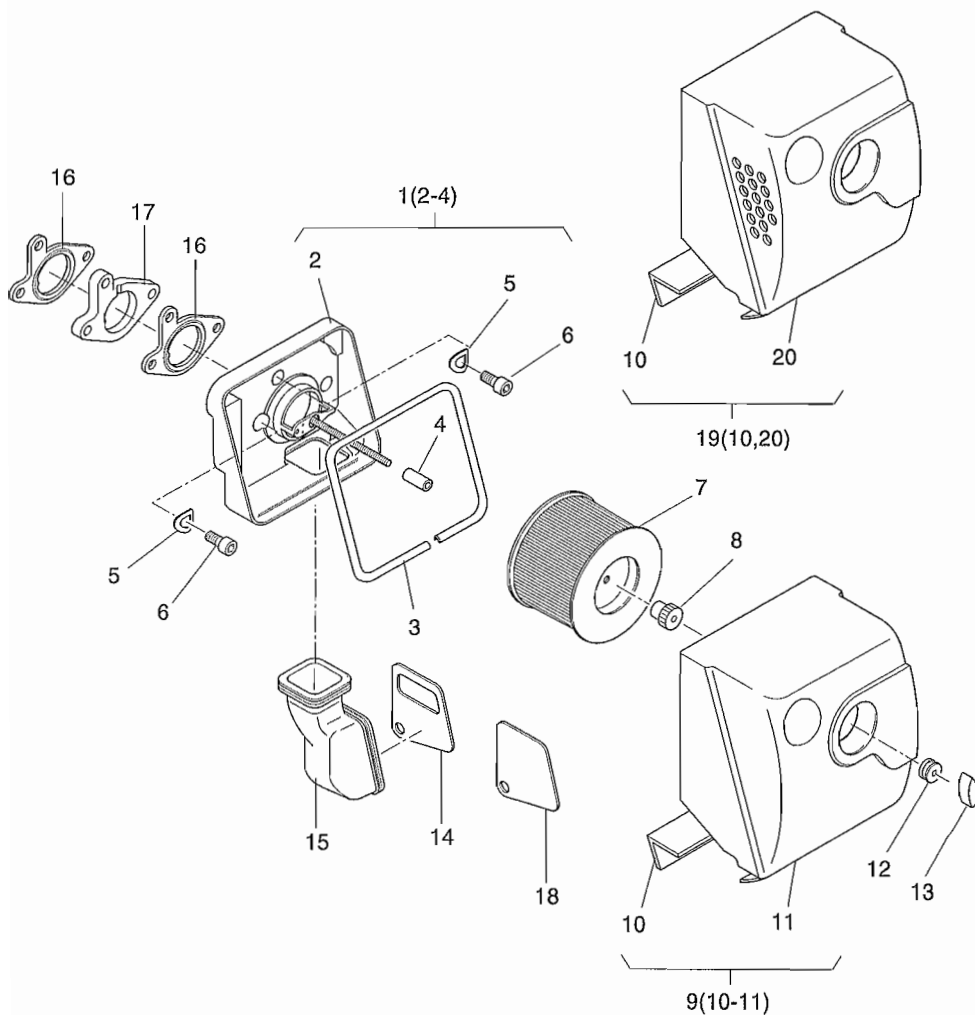

Fig.-No.	HATZ Ident-No.	Stück Qty.	P / W d / D	Bemerkungen Notes
		1B40		
1	01637400	1		
2	-----	-		
3	05167700	1		675 mm
4	05166200	1		32 mm
5	50095100	3		A 8      DIN 137 A3C
6	50171500	3		M 8 x 25    DIN 912 - 8.8 A3C
7	50484100	1	W2	
8	50454300	1		M 6
9	01637300	1		
10	05158000	1		180 mm
11	-----	-		
12	50435800	1		
13	50452200	1		M 6
14	04150800	0...1		
15	04146800	1		
16	05149900	2	d2	
17	05149800	1		
18	04150700	0...1		
19	01691100	1		
20	-----	-		

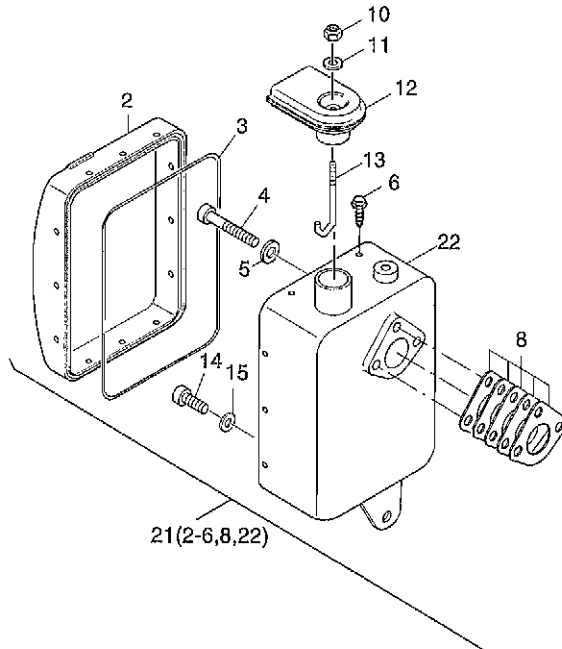
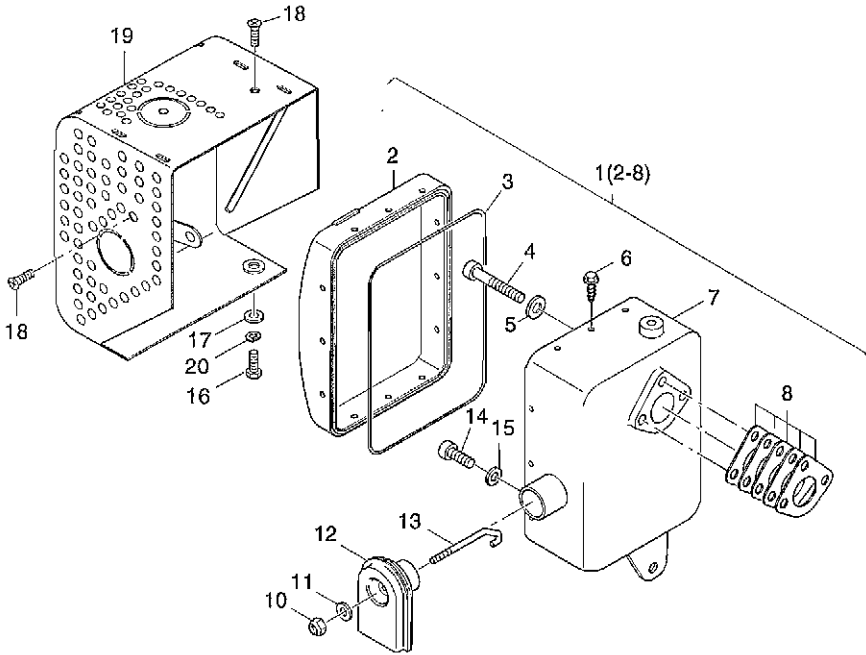

Fig.-No.	HATZ Ident-No.	Stück Qty.	P / W d / D	Bemerkungen Notes
		1B40		
1	01682500	1		
2	-----	-		
3	05199700	1		650 mm
4	50429600	3		M 8 x 35 DIN 912-8.8 C4P
5	04054300	3		8,4 x 21 x 3
6	50487200	12		4,8 x 13
7	-----	-		
8	05157400	5	d5	
10	40028300	1		M 6 SSN 440 - 8 - C3P
11	50144500	1		6,4 DIN 125 - St A3C
12	01655601	1		
13	05177900	1		M 6
14	50170700	1		M 6 x 16 DIN 912 - 8.8 A3C
15	50114300	1		6,4 DIN 7349 - A3C
16	50165500	1		M 6 x 12 DIN 933 - 8.8 A3C
17	50114300	1		6,4 DIN 7349 - A3C
18	50422500	2		M 6 x 12 DIN 7991 - 8.8 A3C
19	01629000	1		
20	50170900	1		6 DIN 128 A3C
21	01701600	1		
22	-----	-		

# A 05

Starter, Generator  
Starter, alternator  
Démarreur, alternateur  
Arrancador, alternador  
Motorino avviamento, alternatore

Tafel Nr.  
Tabl. No.  
Tavola N.

20

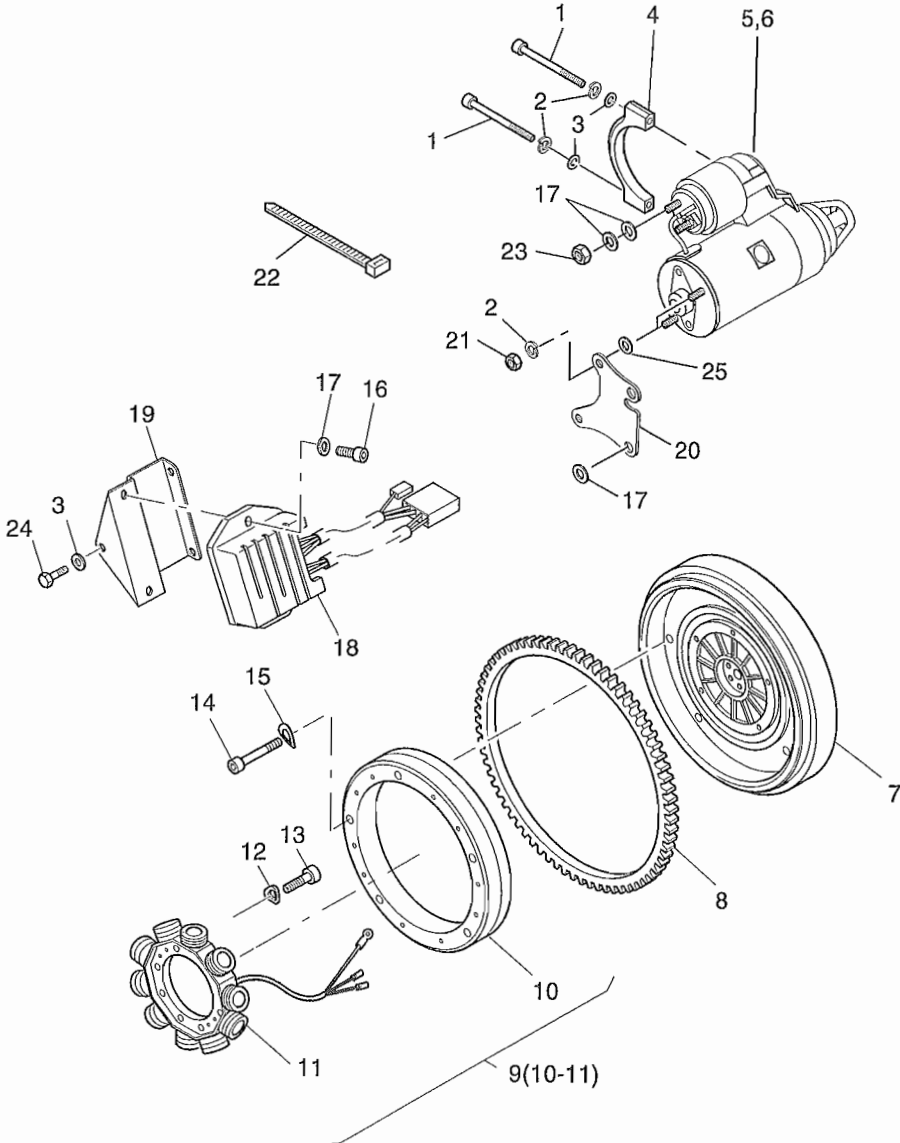

Fig.-No.	HATZ Ident-No.	Stück Qty.	P / W d / D	Bemerkungen Notes
		1B40		
1	50402300	2		M 6 x 70 DIN 912 - 8.8 A3C
2	50170900	4		6 DIN 128 A3C
3	50144500	3		6,4 DIN 125 - St A3C
4	04099100	1		
5	50483500	1		12 V 1,2 kW
6	50483400	1		24 V 1,6 kW
7	04161502	1		
8	04151100	1		
9	50495100	1		12 V - 200 W
10	-----	-		
11	-----	-		
12	50081900	4		A 5 DIN 137 A3C
13	50427100	4		M 5 x 25 DIN 912 - 8.8 A3C
14	50462900	5		M 6 x 25 DIN 6912 - 8.8 A3C
15	50081200	5		A 6 DIN 137 A3C
16	50165400	2		M 8 x 16 DIN 912 - 8.8 A3C
17	50148100	6		8,4 DIN 125 - St A3C
18	05100701	1		12 V
19	01663000	1		
20	05182910	1		
21	50144400	2		M 6 DIN 934 - 8 A3C
22	50439500	3		2,6 x 200
23	50344700	1		M 8 DIN 936 - 5 A3C
24	50025400	1		M 6 x 10 DIN 933 - 8.8 A3C
25	50120000	2		A 6,4 DIN 9021 - St A3C



Fig.-No.	HATZ Ident-No.	Stück Qty.	P / W d / D	Bemerkungen Notes
		1B40		
1	01560801	1		
2	50384401	1		
3	-----	-		
4	-----	-		
5	-----	-		
6	05126402	1		
7	50404900	1		
8	-----	-		
9	-----	-		
10	50149100	2		M 6 x 12 DIN 912 - 8.8 A3C
11	50144500	2		6,4 DIN 125 - St A3C
12	01663400	1		
13	50167400	1		4 / 360
14	50439500	4		2,6 x 200
15	01546800	1		(0) Masse
16	50268600	1		TEMP.
17	50469100	1		OIL



# A 09

Drehzahlverstellung  
Speed control  
Reglage régime  
Ajuste de revolutions  
Comando acceleratore

Tafel Nr.  
Tabl. No.  
Tavola N.

22

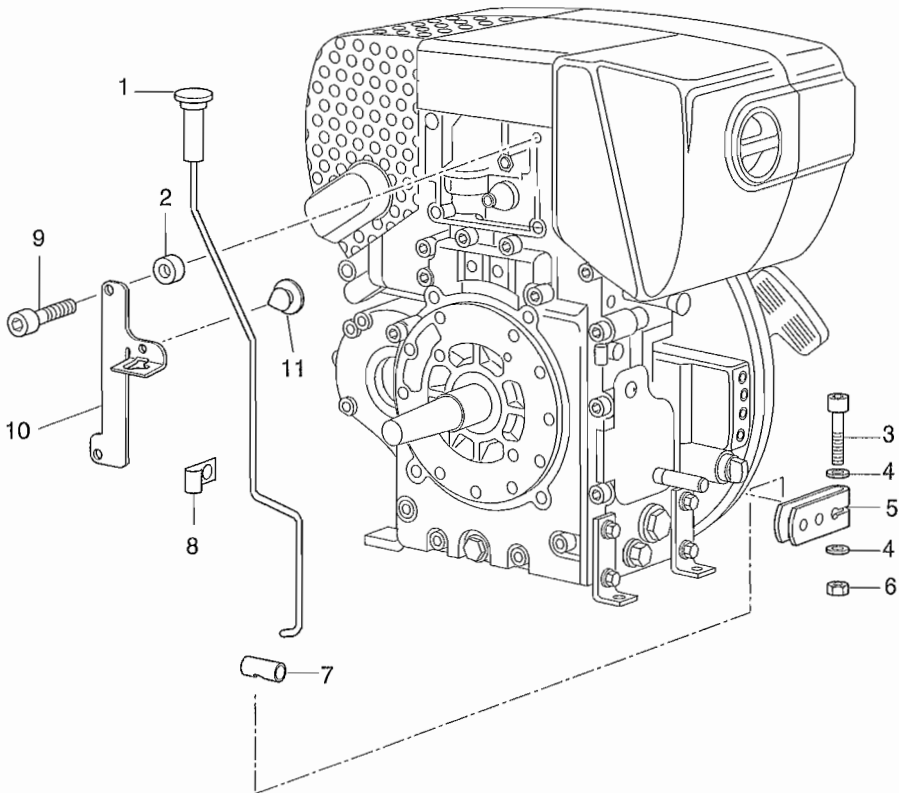
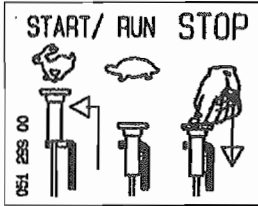

Fig.-No.	HATZ Ident-No.	Stück Qty.	P / W d / D	Bemerkungen Notes
		1B40		
1	01671400	1		
2	03354600	2		7 x 12 x 8
3	50427100	1		M 5 x 25    DIN 912 - 8.8 A3C
4	50216300	2		5,3        DIN 125 - St A3C
5	05117700	1		
6	50094300	1		M 5        DIN 934 - 8 A3C
7	05118500	1		
8	05124600	1		
9	50462900	2		M 6 x 20    DIN 6912-8.8 A3C
10	05191100	1		
11	50482900	1		
12	05129900	1		

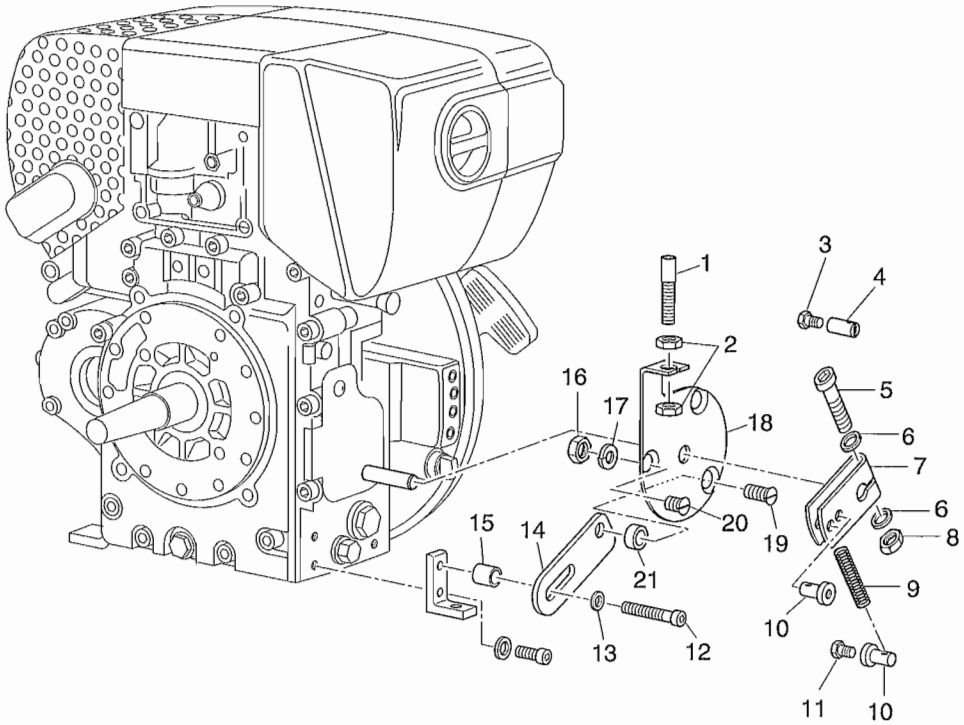

Fig.-No.	HATZ Ident-No.	Stück Qty.	P / W d / D	Bemerkungen Notes
		1B40		
1	05141200	1		M 6
2	50144400	2		M 6      DIN 934 - 8 A3C
3	50025000	1		M 4 x 10    DIN 933-8.8A3C
4	50483000	1		2,2      NR.1120
5	50427100	1		M 5 x 25    DIN 912 - 8.8 A3C
6	50216300	2		5,3      DIN 125 - St A3C
7	05117700	1		
8	50094300	1		M 5      DIN 934 - 8 A3C
9	50484600	1		VD-179E
10	50483100	2		2,2      NR.1450
11	50025000	1		M 4 x 10    DIN 933-8.8A3C
12	50342400	1		M 8 x 50    DIN 6912 - 8.8 A3C
13	50148100	1		8,4      DIN 125 - St A3C
14	05189600	1		
15	03599600	1		8,5 x 13 x 6
16	50328300	1		VM 6      DIN 980 - 8 A3C
17	50208500	1		8      DIN 128 A3C
18	05117600	1		
19	50423900	1		M 6 x 20    DIN 7991 - 10.9 A3C
20	50380800	1		M 6 x 10    DIN 7991 - 8.8 A3C
21	03292900	1		8,2 x 11 x 12

**A 18**

Anbauteile Hydraulikpumpe  
Mount. parts hydr. pump  
Pièces mont.-pompe hydr.  
Piezas mont. bomba hidr.  
Particorari per montaggio pompa idraulica

Tafel Nr.  
Tabl. No.  
Tavola N.

**24**

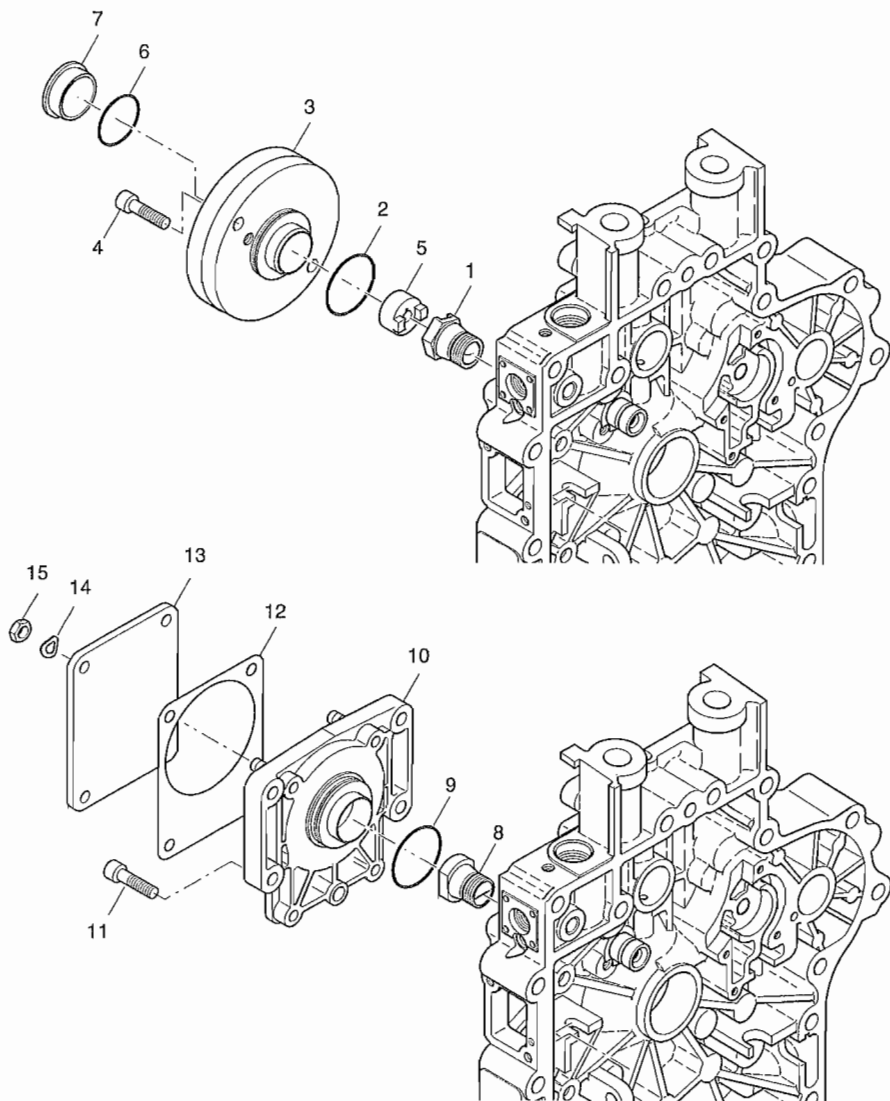

g.-No.	HATZ Ident-No.	Stück Qty.	P / W d / D	Bemerkungen Notes
1B40 - X				
1	01558100	1		
2	50454500	1		44 x 1,5
3	05212200	1		(BOSCH)
4	50175900	2		M 8 x 30    DIN 912 - 8.8 A3C
5	05114700	1		
6	50288200	1		32 x 2,5
7	50163101	1		F 25        Ø 38,8
8	01558000	1		
9	50454500	1		44 x 1,5
10	01690901	1		(BOSCH)
11	50494300	4		M 8 x 20    DIN 912 - 8.8 Tuf.
12	03568000	1		
13	03761600	1		
14	50095100	4		A 8        DIN 137 A3C
15	50148000	4		M 8        DIN 934 - 8 A3C

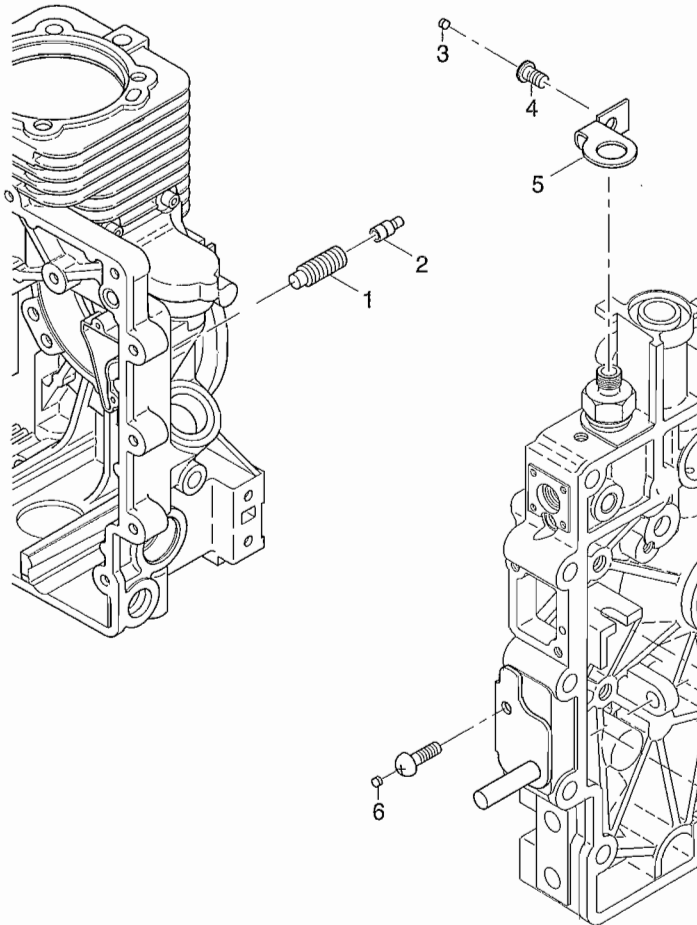

g.-No.	HATZ Ident-No.	Stück Qty.	P / W d / D	Bemerkungen Notes
		1B40		
1	04144401	1		
2	04150500	1		
3	04170600	1		4,15
4	50495000	1		M 6 x 12    DIN 7380-10.9 A3C
5	04195700	1		
6	05201500	1		3



**Serien-Nr.-Änderungen**  
**Serial-code modification list**  
**Modification des Nos de serien**  
**Modificación de los Nos de serie**  
**Modifica dei codici**

**IMT-No.**

---

1 B 40.10

1 B 40.11

01.610