

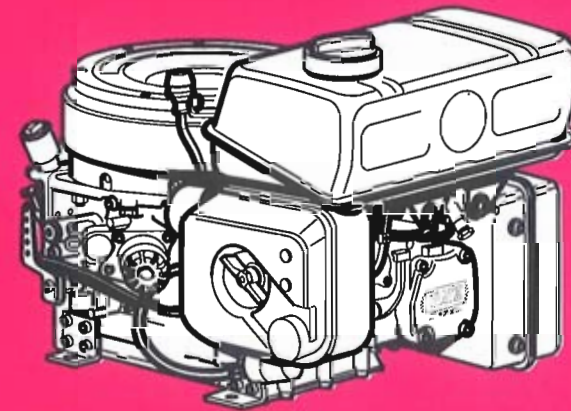

MOTORENFABRIK HATZ • D-94099 Ruhstorf • Germany
Tel.: 0 85 31 / 319-0 • Telefax: 0 85 31 / 31 94 18
eMail: marketing@hatz-diesel.de • <http://www.hatz-diesel.com>

Original-Ersatzteile

Original-spare parts
Pièces de rechange d'origine
Repuestos originales
Pezzi di ricambio originali

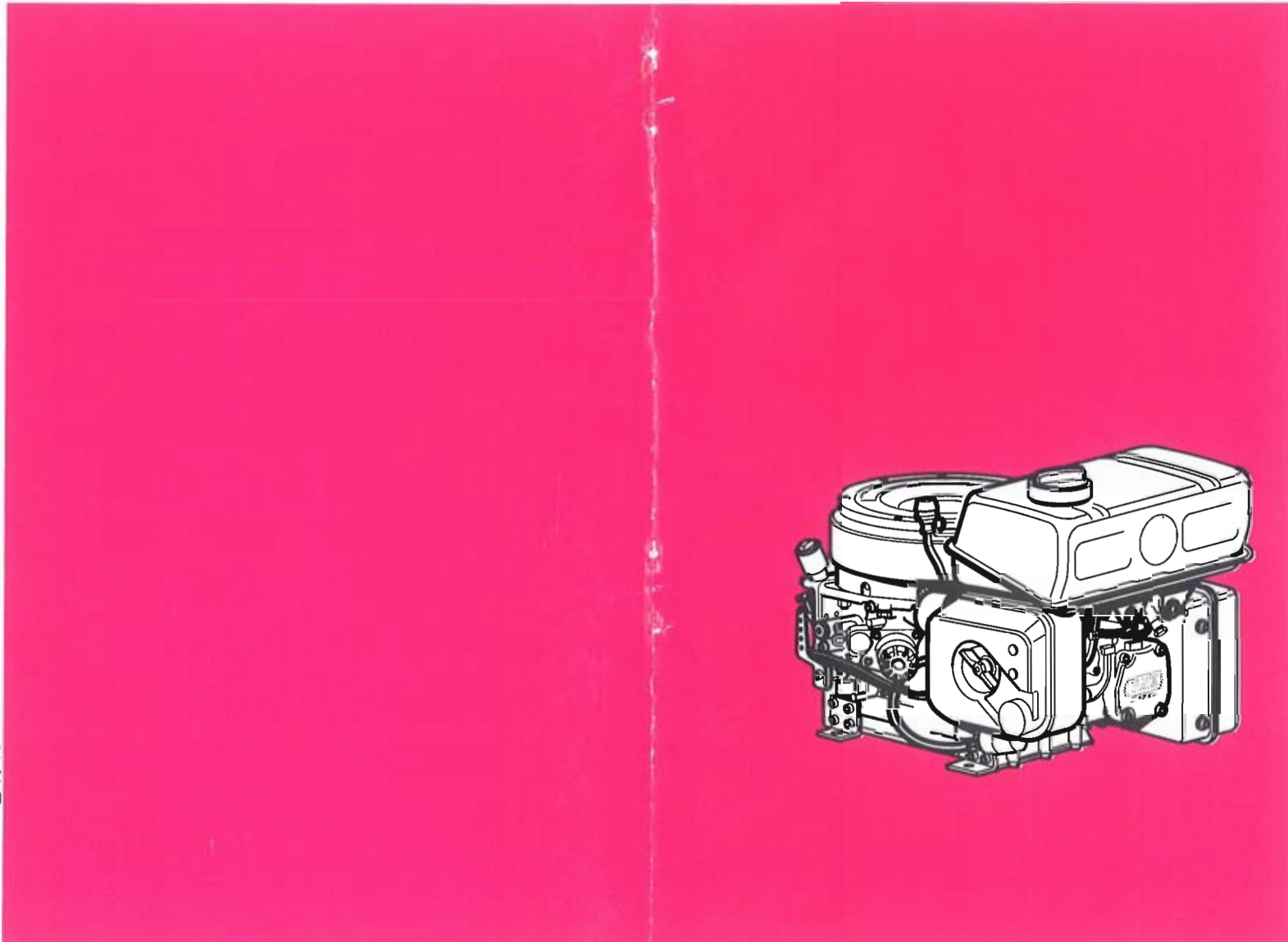

1 D 90 V
1 D 90 W

434 200 71-02.00-0.2
Printed in Germany
DM 3.50

Bestellung für HATZ-Original-Ersatzteile

Order for HATZ Original spare parts

Commande de pièces d'origine HATZ

Pedido de repuestos originales HATZ

Ordine parti di ricambio originali HATZ

1

Besteller / Customer / Client / Cliente / Cliente

2

TYP

MOTOR/FABRIK NO.

MIN-1



3

Ersatzteilliste Nr./ Spare parts list no./ Liste des pièces de rechange no./ Lista de repuestos No./ Lista ricambi n.

1 D 90 V/W . 10

4

Stück / Qty / Q.tà	HATZ Ident No.	Stück / Qty / Q.tà	HATZ Ident No.

5

Versandart / Mode of dispatch / Mode d'expédition / Despacho deseado / Modo di spedizione

Post / Surface / Poste / Correo / Posta Luftfracht / airfreight / frêt aérien / flete aereo / Via aerea

Express / express / exprès / expreso / Espresso

6

Versandadresse / Consignee / Adresse destination / Dirección / Indirizzo di destinazione

- Bestellung an: Order at: Commande à: Pedido a:
- die nächste HATZ-Servicestelle (siehe Servicestellenverzeichnis)
 - your nearest HATZ service station (see service-list)
 - votre station-service HATZ la plus proche (voir liste "Service")
 - al servicio HATZ más cercano (ver cuaderno de Servicio)
 - al più vicino centro di servizio HATZ (vedi lista centri autorizzati)

MOTORENFABRIK HATZ
D-94099 RUHSTORF
 Tel: 0 85 31 / 319 - 0
 Fax: 0 85 31 / 31 94 21
 eMail: Hatz.Werbung@t-online.de
 http://www.hatz.com

	Inhaltsverzeichnis	Index	
M ..	Grundmotor	Basic engine	
00	Ersatzteilsätze	Spare part kits	01
34	Zubehör	Accessories	02
01	Kurbelgehäuse	Crankcase	03+04
02, 03	Kurbelwelle, Lagerflansch	Crankshaft, bearing flange	05
04	Nockenw., Massenausgleich	Camshaft, Compensation of masses	06
05, 06	Kolben, Pleuelstange, Zylinder	Piston, conrod, cylinder	07
07	Zylinderkopf	Cylinder head	08
09, 17	Stoßstange, Schwungrad	Pushrod, flywheel	09
10,	Ölpumpe, Regler	Oil pump, governor	10
11	Steuerdeckel	Timing cover	11
12, 14	Startfüllung, Einspritzausrüstung	Extra fuel device, Injection equipment	12
26	Luftführung	Air ducting	13
31 – 32	Drehzahlverstellung, Entlüftung,	Speed control, breather,	14
A ..	Zusatzrüstung	Equipments	
01	Kraftstoffbehälter	Fuel tank	15
01	Förderpumpe	Fuel feed pump	16
02	Luftfilter	Air filter	17
03	Abgasdämpfer	Exhaust silencer	18
05	Starter,Generator, Armaturenkasten	Starter, alternator, Instrument box	19
09, 11	Abstellvorr., Hubmagnet	Stop device, lifting magnet	21
18	Anbauteile Hydraulikpumpe	Mount. parts hydr. pump	22

Sommaire:	indice		
M ..	Moteur de base	Motor de base	
00	Jeux de pièces de rechange	Juegos de piezas de recambios	01
34	Accessoires	Accesorios	02
01	Carter moteur	Caja cigueñal	03+04
02, 03	Vilebrequin, palier	Cigüeñal, brida de cojinete	05
04	Arbre à cames	Arbol de levas	
	Equilibrage des masses	Compensación de las masas	06
05, 06	Piston, bielle, cylindre	Émbolo, biela, cilindro	07
07	Culasse	Culata	08
09, 17	Tige de culbuteur, volant	Varilla de balancín, volante	09
10	Pompe à huile, regulateur	Bomba de aceite, regulador	10
11	Couvercle distribution	Tapa de mando	11
12, 14	Surcharge	Sobre aliment.-arranque,	
	Equipment d'injection	Equipo de inyección	12
26	Carter ventilation	Conducción de aire	13
31 – 32	Réglage régime, purge d'air	Ajuste de revoluciones, purgo de aire,	14
A ..	Accessoires	Equipos	
01	Reservoir à carburant	Depósito combustible	15
01	Pompe d'alimentation	Bomba de alimentación	16
02	Filtre à air	Filtro de aire	17
03	Silencieux	Silenciador	18
05	Demarreur, alternateur	Arrancador, alternador	19
	Boitier de bord	Cuadro de mando	20
09,11	Dis. d'arrêt, el. aimant	Disp. desconect., elevador magnet.	21
18	Pièces mont.-pompe hydr.	Piezas mont. bomba hydr.	22

Indice

Tavola N.

M .. Motore de base

00	Serie guarnizioni	01
34	Kit accessori	02
01	Basamento motore	03+04
02, 03	Albero a gomito, supporto	05
04	Albero a camme, Contrappesi di equilibratura	06
05, 06	Pistone, biella, cilindro	07
07	Testa	08
09, 17	Asta bilancieri, volano	09
10	Pompa olio, regolatore	10
11	Coperchio distribuzione	11
12, 14	Supplemento, Equipaggiamento iniezione	12
26	Carter ventilatore	13
31 – 32	Regolatore di giri, sfiatatóio	14

A .. Accessori

01	Serbatoio combustibile	15
01	Pompa A. C.	16
02	Filtro aria	17
03	Marmita	18
05	Motorino avviamento, alternatore, Cruscotto	19 20
09,11	Leva stop, magnete stop	21
18	Particolari per montaggio pompa idraulica	22

M 00

Ersatzteilsätze
Spare part kits
Jeux de pièces de rechange
Juegos de piezas de recambios
Serie guarnizioni

Tafel Nr.
Tabl. No.
Tavola N.

01

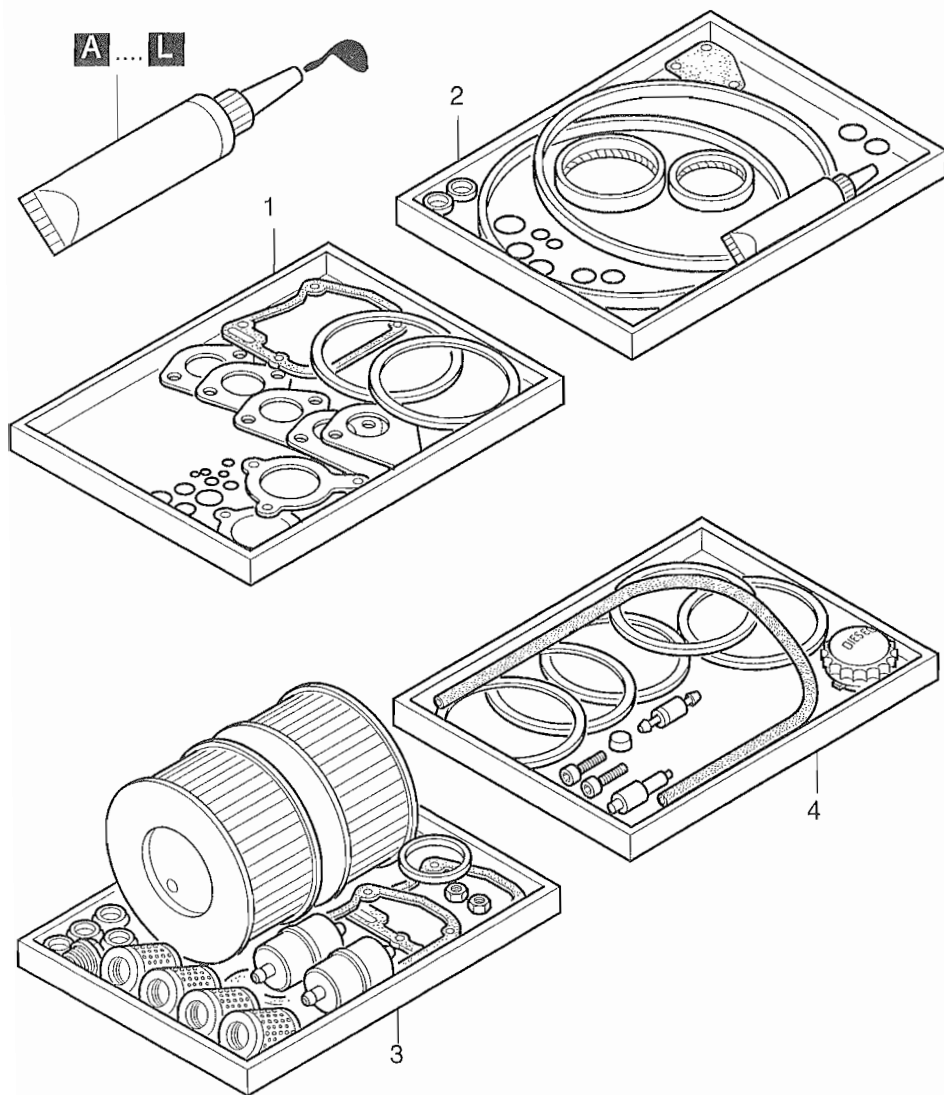

Fig.-No.	HATZ Ident-No.	Stück Qty.	P / W d / D	Bemerkungen Notes
1D90V/W				
<p>W: Im Wartungssatz enthalten. Incl. in maintenance kit. Contenu dans le jeu d'entretien. Incluido en el juego de mantenimiento. Contenuto nella serie manutenzione.</p> <p>d: Im Dichtungssatz f. 1 Zyl.-Kopf enthalten. Incl. in gasket set f. 1 cyl. head. Contenu dans le jeu de joint p. 1 culasse. Incluido en el juego de juntas p. 1 culata. Contenuto nella serie guarnizioni p. 1 testa.</p> <p>P: Im Pannensatz enthalten. Incl. in emergency kit. Contenu dans le jeu secur. Incluido en el juego para averias. Contenuto nella serie di prima necessità.</p> <p>D: Im Dichtungssatz Kurbelgeh. Incl. in gasket set crankcase. Contenu dans le jeu de joints carter moteur. Incluido en el juego de juntas caja cigueñal. Contenuto nella serie guarnizioni basamento.</p> <p>1: Anzahl pro Satz - Qty. per kit Quantite p. jeu - Cantidad p. juego. Quantità per serie</p>				
1	015 928 00	1	P 1	Dichtungssatz für 1 Zylinderkopf Gasket set for 1 cyl. head Jeu de joint p. 1 culasse Juego de juntas para 1 culata Serie guarniziono per 1 testa
2	016 464 00	1		Dichtungssatz für Kurbelgehäuse Gasket set for crankcase Jeu de joints p. carter moteur Juego de juntas para caja cigueñal Serie guarnizioni basamento
3	012 494 10	1		Wartungssatz für 1000 h
3	012 924 11	1	*	1000 hours maintenance kit Kit d'entretien 1000 heures - Juego de piezas para servicio 1000 horas Kit di manutenzione a 1000 ore
4	015 997 00	1		Pannensatz - Emergency kit Kit de secours - Juego para averias Kit di prima necessità

* ohne Ölfilter, without oil filter, sans filtre à huile, sin filtro de aceite, senza cartuccia oolio

M 34

Zubehör
Accessoires
Accessoires
Accessoires
Kit accessori

Tafel Nr.
Tabl. No.
Tavola N.

02

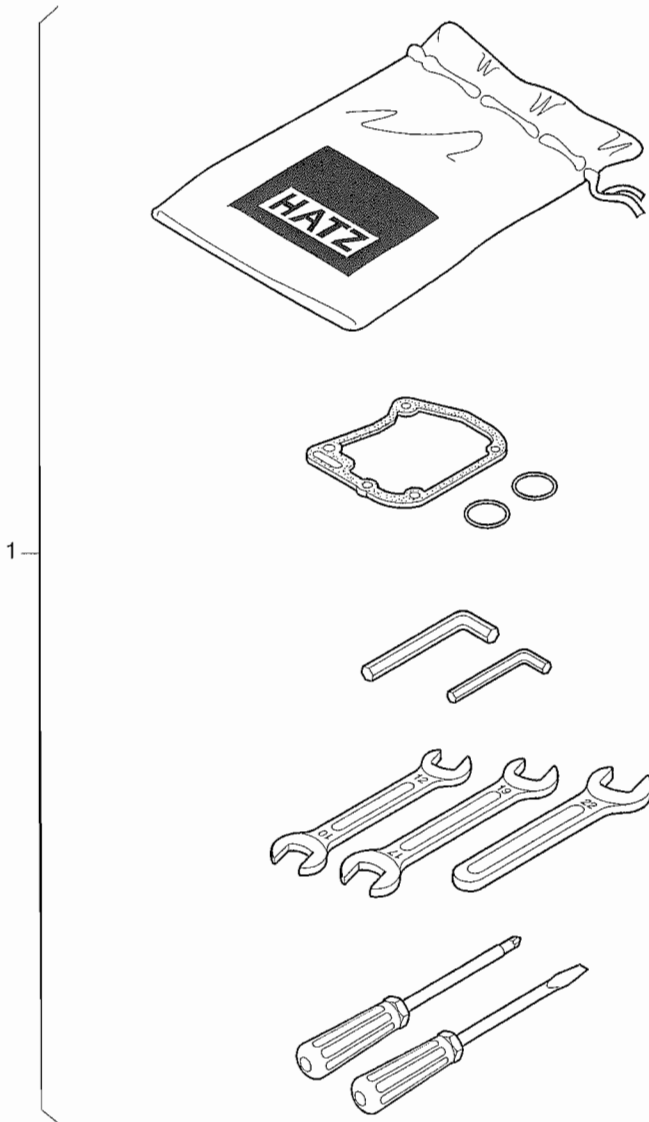

Fig.-No.	HATZ Ident-No.	Stück Qty.	P / W d / D	Bemerkungen Notes
1D90V/W				
1	012 475 11	1		Zubehörsatz - Accessoires kit Sort. accessoires Juego de accesorios Serie accessorie

Dicht- und Klebstoffe
Sealing- and bonding adhesives
Etanchéifiant et Colle

Materias para empaquetar y pegar
Adesivi e collanti

A = 502 230 01	Loctite Activator N	500 ml	}	siehe Hinweis auf den einzelnen Bildtafeln as specified in the individual tables suivant les remarques sur les tableau correspondant según las indicaciones de las tablas correspondientes seguire le indicazioni sul quadro corrispondente
B = 502 231 00	Loctite 573	50 ml		
C = 502 232 00	Loctite 601	50 ml		
D = 502 233 00	Loctite 221	50 ml		
E = 502 234 00	Loctite 648	10 ml		
F = 502 238 00	Technicoll 8058	0,75 kg		
+ 502 239 00	Technicoll 8367	0,75 kg		
G = 502 565 01	Loctite IS 407	20 g		
H = 502 825 01	Silicon	30 ml		
J = 502 830 03	Hochtemp. Paste	100 ml		
K = 503 426 00	Hochtemp. Fett	100 g		
L = 502 566 00	Silicon sealer	100 g		

M 01

Kurbelgehäuse
Crankcase
Carter moteur
Caja cigueñal
Basamento motore

Tafel Nr.
Tabl. No.
Tavola N.

03

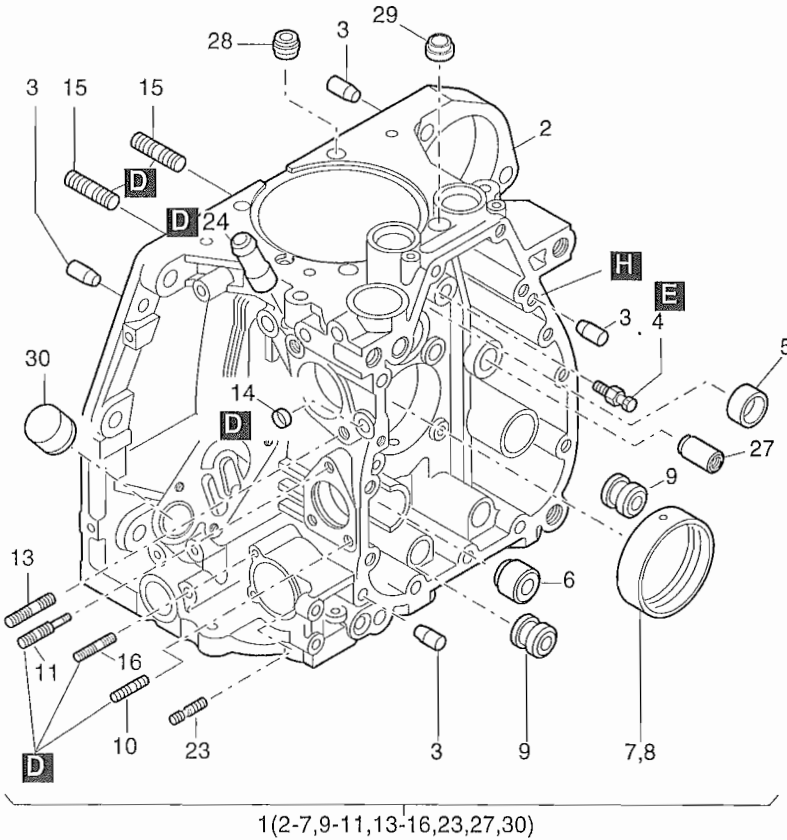

Fig.-No.	HATZ Ident-No.	Stück Qty.	P / W d / D	Bemerkungen Notes
1D90V/W				
1	016 247 00	1		
2	-----	-		
3	502 491 01	4		8 M 6 x 20 DIN 6325
4	037 939 00	1		
5	037 938 00	1		
6	037 940 00	0...1		Ø 22 mm „V“
7	037 937 00	1		
8	040 337 00	1		- 0,5 mm
9	040 008 00	1...2		Ø 22 mm, s. Tafel., Tabl. 16, Pos. 4
10	501 443 00	2		M 6 x 16 DIN 835-A3C
11	037 945 10	1		
13	500 983 00	2		M 8 x 20 DIN 835-8.8 A3C
14	503 255 00	1		10 DIN 443-St A3C
15	500 378 00	8		M 8 x 22 DIN 835-10.9
16	503 282 00	2		M 6 x 22 DIN 835-8.8 A3C
23	040 874 00	1		M 6 x 22
24	-----	-		
27	041 050 00	1		Ø 15 mm „V“
28	504 598 00	2		
29	040 845 00	2	d2	
30	-----	-		

M 01

Kurbelgehäuse
Crankcase
Carter moteur
Caja cigueñal
Basamento motore

Tafel Nr.
Tabl. No.
Tavola N.

04

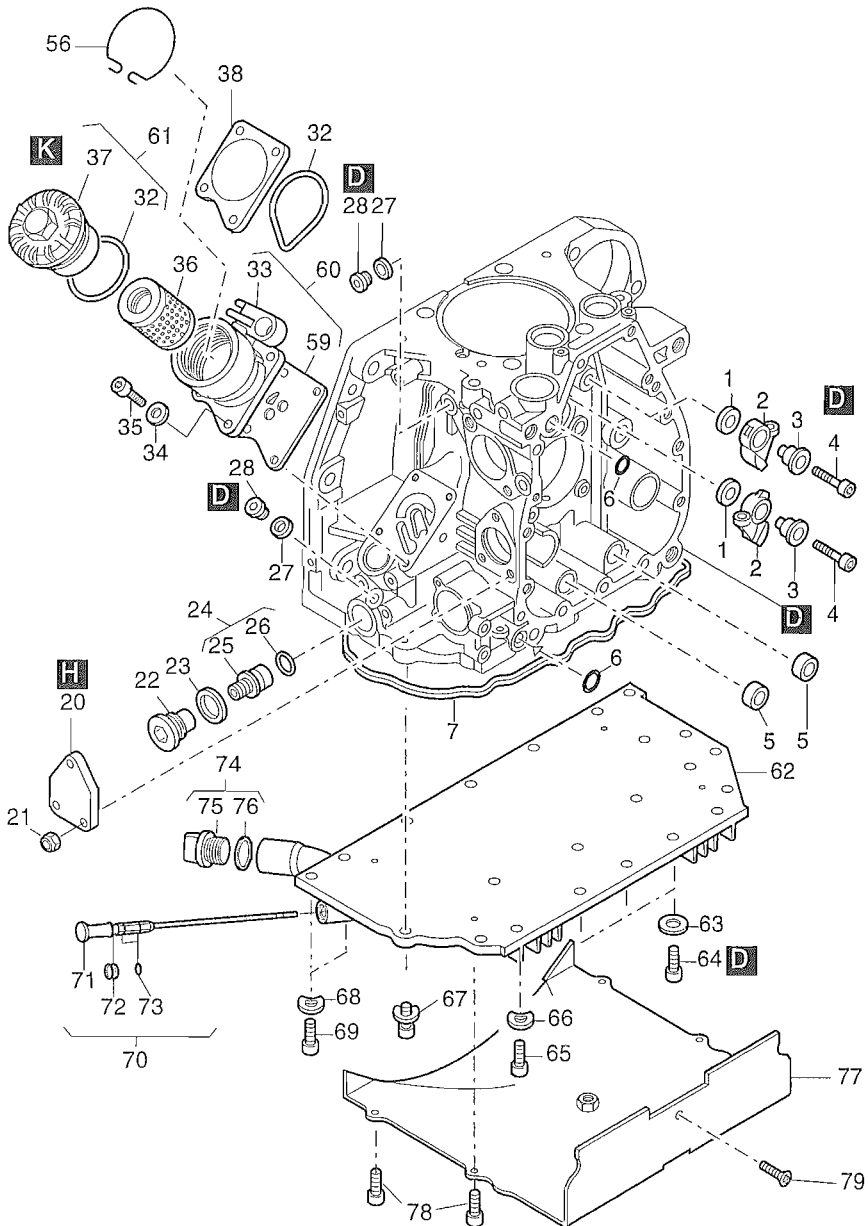

Fig.-No.	HATZ Ident-No.	Stück Qty.	P / W d / D	Bemerkungen Notes
1D90V/W				
1	037 941 00	2		
2	037 943 00	2		
3	037 942 01	2		
4	500 510 00	2		M 6 x 30 DIN 912-8.8
5	037 958 00	2	D2	12 x 18,3 x 7,3
6	503 290 00	2	D3	9,5 x 2,5
7	037 951 00	1	D1	265 x 269,4 x 3,6
20	037 947 00	1		
21	503 283 00	3		VM 6 DIN 980-8 A3C
22	013 212 00	1		M 24 x 1,5
23	502 864 00	1	D1	A 24 x 29 DIN 7604-Cu
24	013 211 00	1		
25	-----	-		
26	504 604 00	1	D1	18 x 2
27	500 624 00	2	D2	A 10 x 13,5 DIN 7603-Cu
28	500 623 00	2		M 10 x 1 DIN 908-5.8 A3C
32	503 292 00	2	D2, W1	50 x 55 x 3
33	-----	-		
34	500 812 00	4		A 6 DIN 137 A3C
35	501 706 00	4		M 6 x 20 DIN 912-8.8 A3C
36	014 800 00	1	W4	
37	-----	-		
38	040 334 01	1		
56	040 840 00	1		
59	050 689 00	1	D1	
60	013 183 00	1		
61	012 489 01	1		
62	041 373 00	1		
63	501 629 00	6		A 14 x 18 DIN 7603-Cu
64	501 715 00	6		M 8 x 25 DIN 912-8.8 A3C
65	501 775 00	1		M 8 x 40 DIN 912-8.8 A3C
66	500 951 00	1		A 8 DIN 137 A3C
67	504 176 00	11		M 8 x 25 Z4 DIN 912-8.8 A3C/6900
68	500 951 00	2		A 8 DIN 137 A3C
69	501 710 00	2		M 8 x 45 DIN 912-8.8 A3C
70	013 406 00	1		
71	-----	-		
72	503 244 00	1	D1	V-8S
73	400 220 00	2	D2	5 x 2

M 01

Kurbelgehäuse
Crankcase
Carter moteur
Caja cigueñal
Basamento motore

Tafel Nr.
Tabl. No.
Tavola N.

04

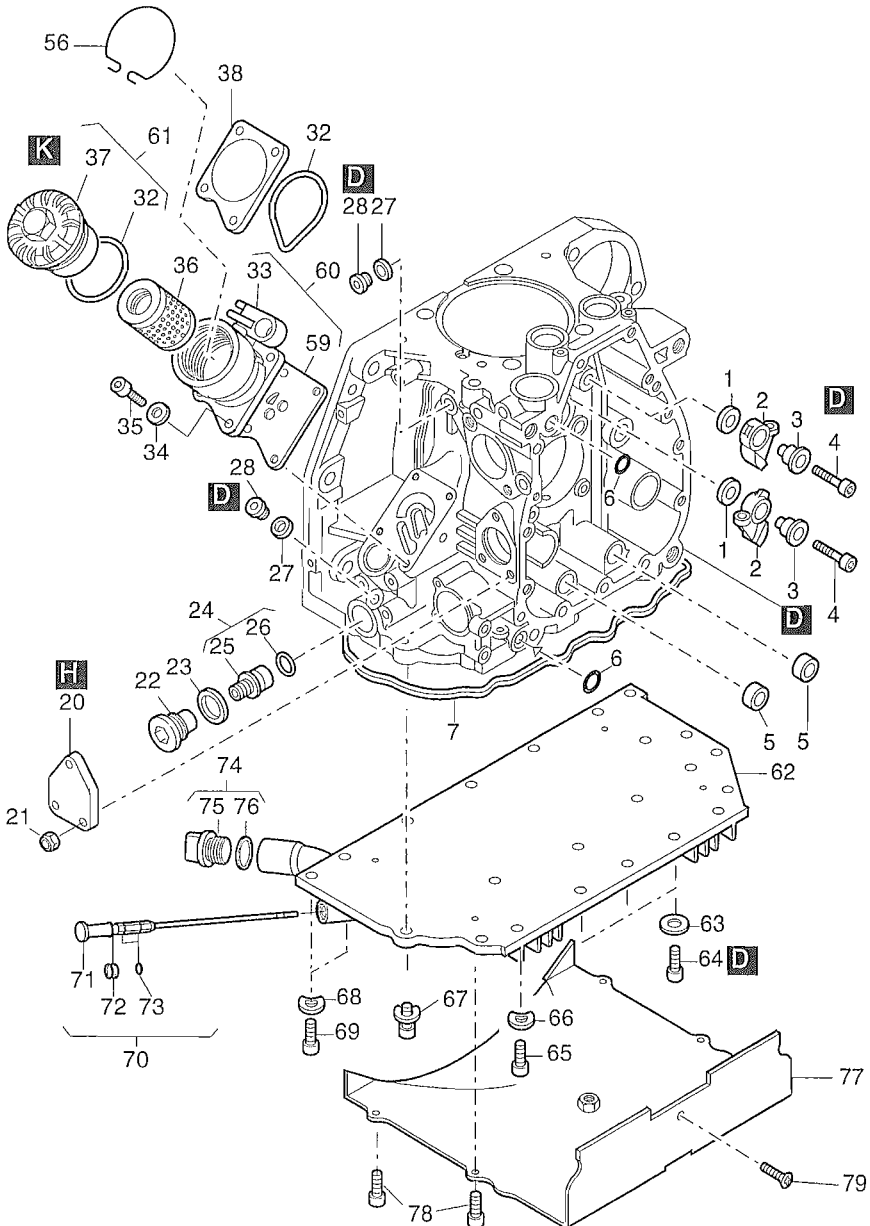

Fig.-No.	HATZ Ident-No.	Stück Qty.	P / W d / D	Bemerkungen Notes
		1D90V/W		
74	016 131 00	1		
75	-----	-		
76	041 250 00	1	D1	26 x 35 x 3
77	013 408 00	1		
78	501 126 00	4		M 5 x 10 DIN 6912-8.8 A3C
79	504 355 00	1		M 5 x 12 DIN 7991-8.8 A3C

M 02

Kurbelwelle
Crankshaft
Vilebrequin
Cigüeñal
Albero a gomito

M 03

Lagerflansch
Bearing flange
Palier
Brida de cojinete
Supporto

Tafel Nr.
Tabl. No.
Tavola N.

05

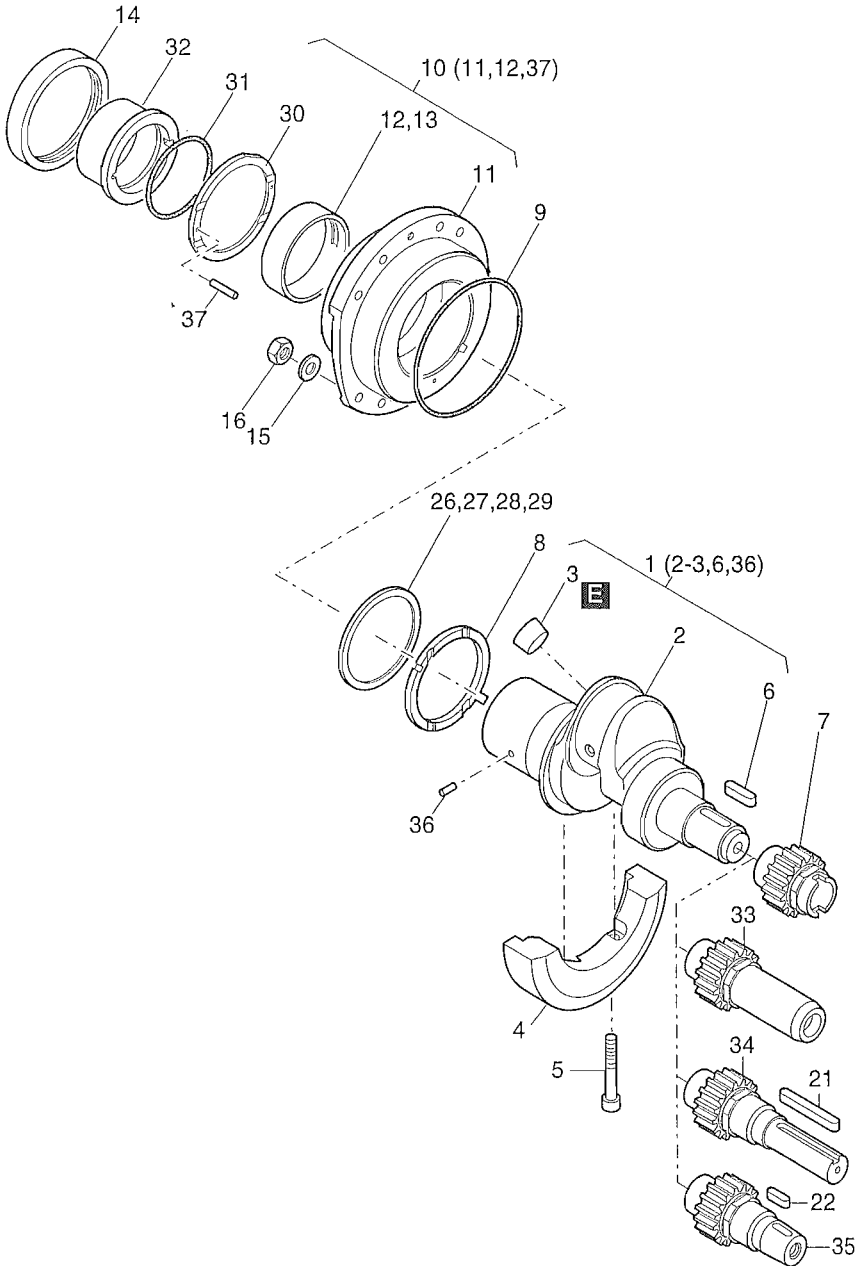

Fig.-No.	HATZ Ident-No.	Stück Qty.	P / W d / D	Bemerkungen Notes
1D90V/W				
1	013 419 00	1		
2	-----	-		
3	500 872 00	1		28 DIN 443
4	037 960 00	1		
5	500 550 00	2		M 10 x 50 DIN 912-10.9
6	503 626 00	1		A 6 x 4 x 32 DIN 6885 St. 60
7	037 961 20	1		
8	040 006 00	1		
9	502 249 00	1	D1	123 x 2,5
10	013 423 00	1		
11	-----	-		
12	040 068 00	1		
13	040 361 00	1		- 0,5 mm
14	504 781 00	1	D1	68 x 90 x 10
15	504 136 00	8		8,4 300 HV DIN 125A-A3C
16	503 643 00	8		M 8 DIN 934-10 A3C
21	039 627 00	1		A 6,35 x 63
22	500 178 00	1		4 x 6,5 DIN 6888
26	041 431 00	0...		70 x 84 x 0,10
27	041 434 00	0...		70 x 84 x 0,15
28	041 432 00	0...		70 x 84 x 0,20
29	041 433 00	0...		70 x 84 x 0,30
30	041 430 00	1		
31	504 786 00	1	D1	62 x 2
32	041 429 00	1		
33	041 418 00	1		HP s. Taf., Tabl. 22 - Pos. 11
34	041 455 00	1		SAE...2 Ø 1" Zyl., Cyl.
35	041 456 00	1		ital. ...3
36	041 435 00	2		5 x 8
37	504 342 00	2		2,5 x 8 DIN 7344

M 04

Nockenwelle, Massenausgleich
Camshaft, compensation of masses
Arbro à cames, équilibrage
Arbol de levas, compensación de las masas
Albero a camme, masse equilibratura

Tafel Nr.
Tabl. No.
Tavola N.

06

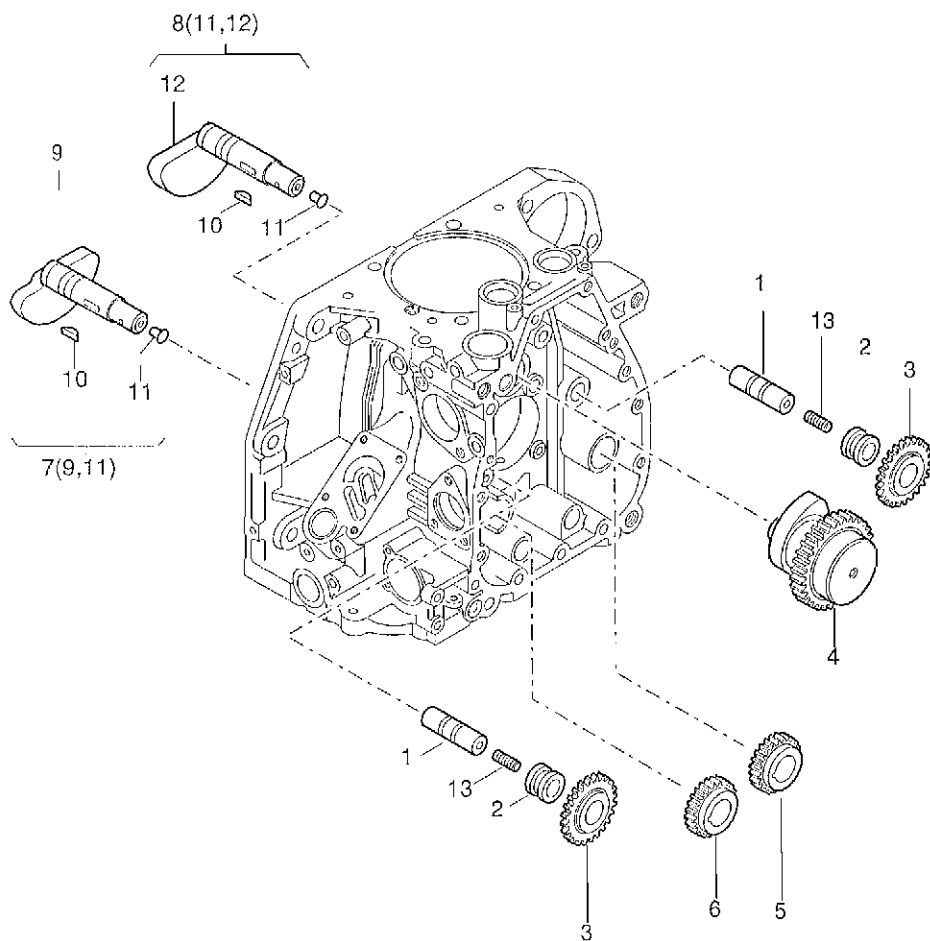

Fig.-No.	HATZ Ident-No.	Stück Qty.	P / W d / D	Bemerkungen Notes
		1D90V/W		
1	037 964 01	2		W
2	037 965 01	2		W
3	012 420 00	2		W
4	041 423 00	1		V/W
5	037 968 00	1		W
6	037 969 00	1		W
7	012 673 00	1		W
8	012 672 00	1		W
9	-----	-		
10	503 249 00	2		W 3 x 3,7 DIN 6888 St. 60
11	-----	-		
12	-----	-		
13	503 580 00	2		M 8 x 10 DIN 913 Tuf.

M 05

Kolben, Pleuel
Piston, Conrod
Piston, bielle
Embolo, biela
Pistone, biella

M 06

Zylinder
Cylinder
Cylindre
Cilindro
Cilindro

Tafel Nr.
Tabl. No.
Tavola N.

07

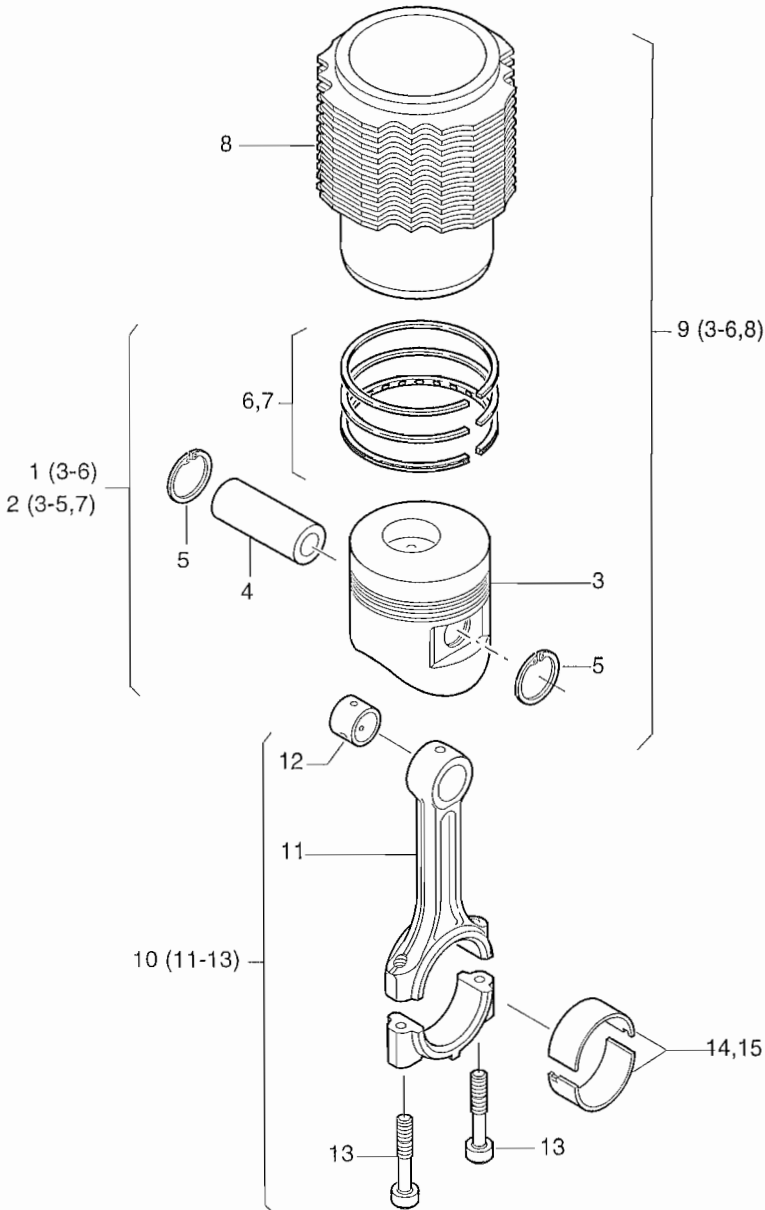

Fig.-No.	HATZ Ident-No.	Stück Qty.	P / W d / D	Bemerkungen Notes
		1D90V/W		
1	013 317 00	1		
2	013 327 00	1		+ 0,5 mm
3	-----	-		
4	504 619 00	1		30 x 15 x 75
5	504 620 00	2		30 x 1,2
6	013 318 00	1		
7	013 333 00	1		+ 0,5 mm
8	-----	-		
9	015 926 00	1		
10	012 440 10	1		
11	-----	-		
12	040 322 00	1		
13	040 018 10	2		
14	040 019 00	1		
15	040 331 00	1		-0,5 mm

M 07

Zylinderkopf
Cylinder head
Culasse
Culata
Testa

Tafel Nr.
Tabl. No.
Tavola N.

08

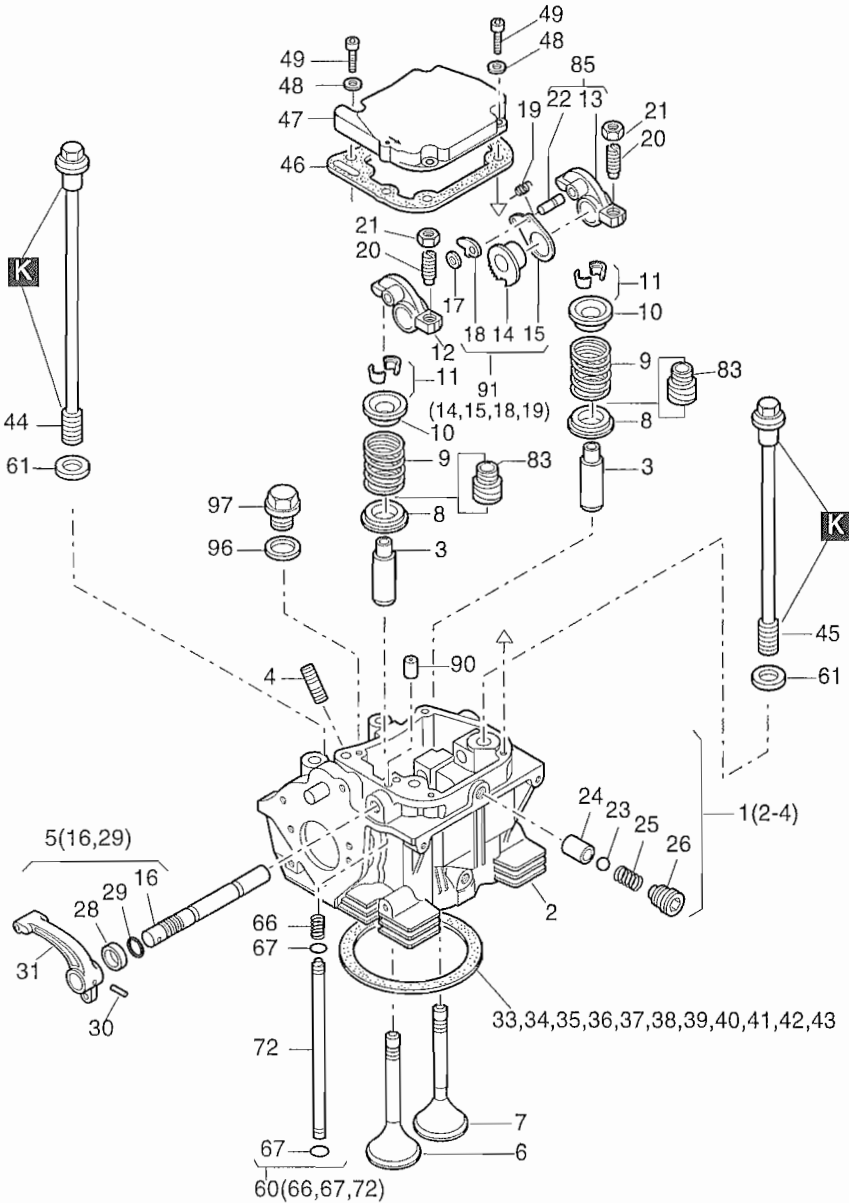

Fig.-No.	HATZ Ident-No.	Stück Qty.	P / W d / D	Bemerkungen Notes
1D90V/W				
1	015 927 00	1		
2	-----	-		
3	040 087 11	2		
4	500 384 00	1	M 8 x 35	DIN 835-8.8 A3C
5	014 689 20	1		
6	040 910 01	1		
7	040 911 00	1		
8	040 052 01	2		
9	041 520 00	2		
10	040 054 01	2		
11	037 863 00	2		
12	040 037 10	1		
13	-----	-		
14	-----	-		
15	037 784 01	1		
16	-----	-		
17	501 172 00	1		
18	033 657 10	1		
19	033 660 01	1		
20	037 830 00	2		
21	031 731 00	2	W2	
22	-----	-		
23	501 238 00	1		7 mm III DIN 5401
24	040 047 00	1		
25	040 048 00	1		
26	012 452 00	1		
28	040 489 00	1	d1	12 x 18 x 5
29	400 224 01	1	d2	8 x 2
30	500 347 00	1		4 x 22 DIN 1481
31	040 098 10	1		
33	041 193 00	0...1		0,3 mm
34	041 194 00	0...1		0,4 mm
35	041 195 00	0...1		0,5 mm
36	041 196 00	0...1		0,6 mm
37	041 197 00	0...1	d1	0,7 mm
38	041 198 00	0...1	d1	0,8 mm
39	041 199 00	0...1	d1	0,9 mm
40	041 200 00	0...1		1,0 mm
41	041 201 00	0...1		1,1 mm

M 07

Zylinderkopf
Cylinder head
Culasse
Culata
Testa

Tafel Nr.
Tabl. No.
Tavola N.

08

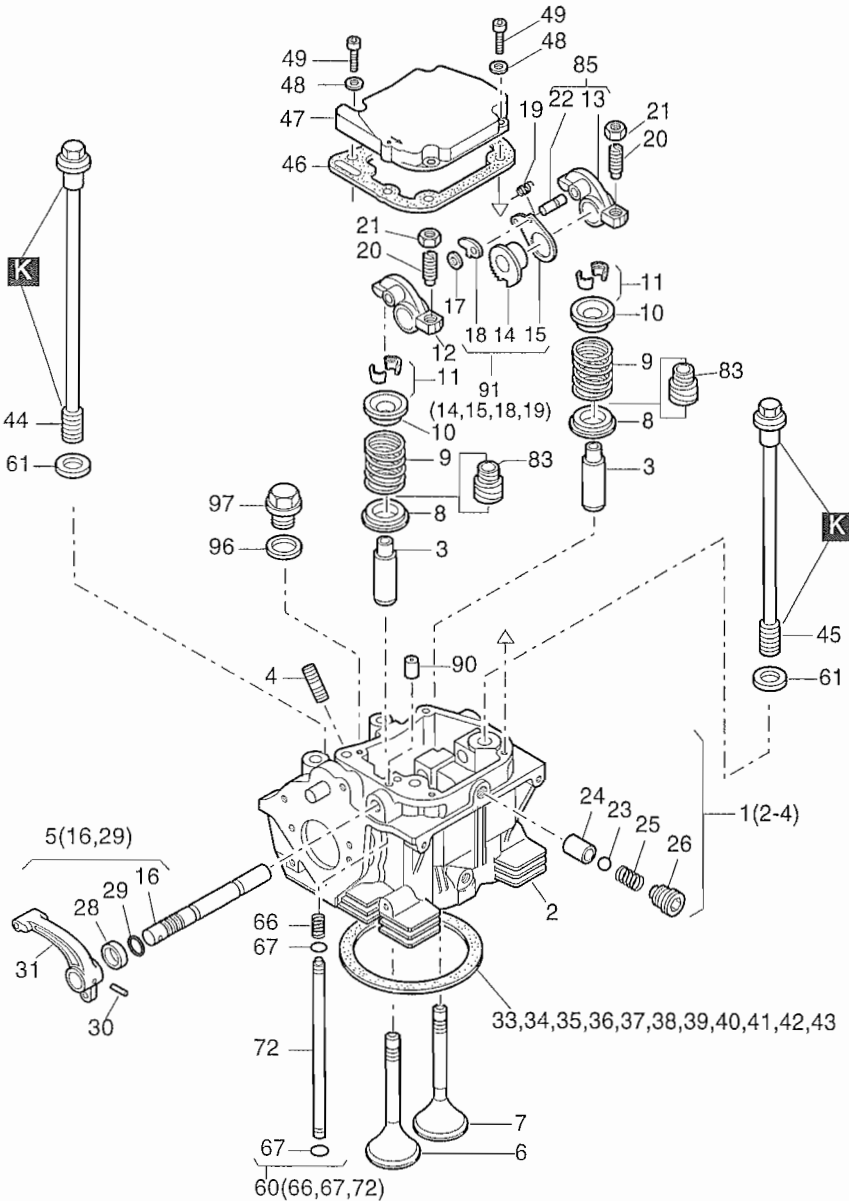

Fig.-No.	HATZ Ident-No.	Stück Qty.	P / W d / D	Bemerkungen Notes
1D90V/W				
42	041 202 00	0...1		1,2 mm
43	041 203 00	0...1		1,3 mm
44	040 032 00	2		305 mm
45	040 033 00	2		258 mm
46	040 061 11	1	d1, W3	
47	012 454 12	1		
48	500 812 00	4	P4	A6 DIN 137 A3C
49	501 708 00	4	P2	M 6 x 25 DIN 912-8.8
60	012 697 00	1		
61	034 575 00	4		12,5 x 24 x 2,5
66	040 042 00	1		
67	503 301 00	2	d2	4 x 1,2
72	-----	-		
83	504 052 00	2	d2	
85	012 850 10	1		
90	041 043 00	1		
91	015 576 00	1		
96	500 011 00	1	d1	A 12 x 15,5 DIN 7603-Cu
97	502 214 00	1		M 12 x 1,5 DIN 910-St. A3C

M 09

Stoßstangen
Pushrod
Tige de culbuteur
Varilla de balancin
Asta bilanciare

M 17

Schwungrad
Flywheel
Volant
Volante
Volano

Tafel Nr.
Tabl. No.
Tavola N.

09

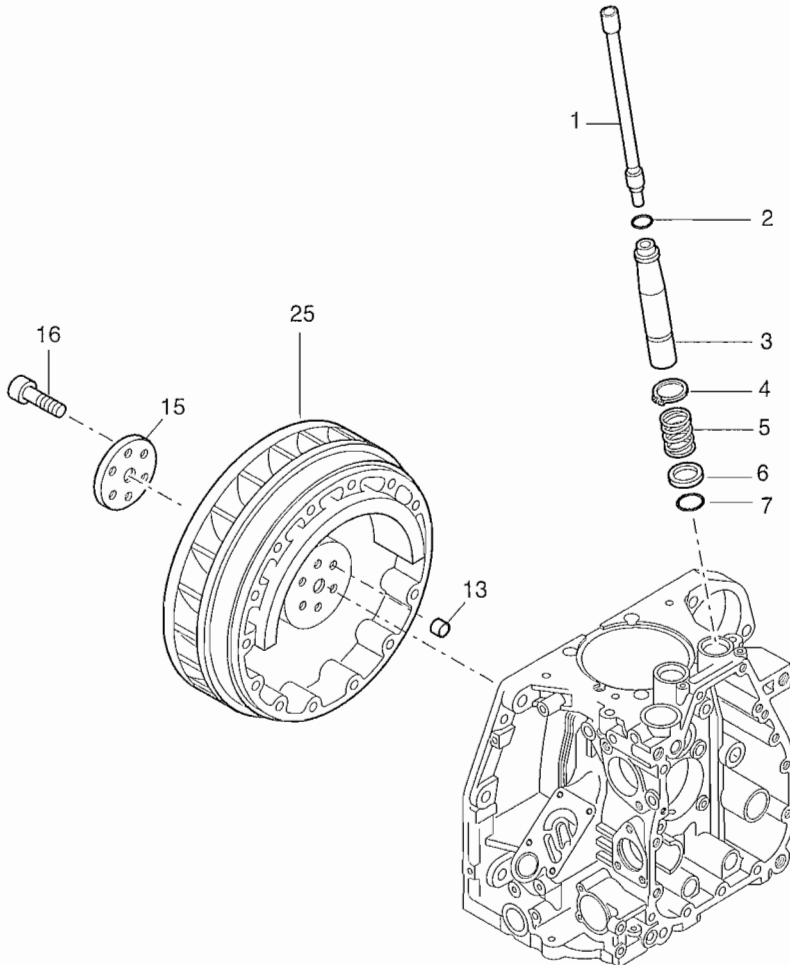

Fig.-No.	HATZ Ident-No.	Stück Qty.	P / W d / D	Bemerkungen Notes
1D90V/W				
1	012 443 10	2		
2	503 302 00	2	d2	19 x 3
3	040 025 00	2		
4	503 470 00	2	P2	AS 24 x 1,75 DIN 471
5	040 026 00	2		
6	040 020 00	2		
7	503 303 00	2		23 x 3
13	031 237 00	1		
15	040 074 10	1		
16	503 631 00	6		M 12 x 1,5 x 40 DIN 912-10.9
25	041 401 00	1		

M 10

Ölpumpe, Regler
Oil pump, governor
Pompe à huile, régulateur
Bomba de aceite, regulador
Pompa olio, regolatore

Tafel Nr.
Tabl. No.
Tavola N.

10

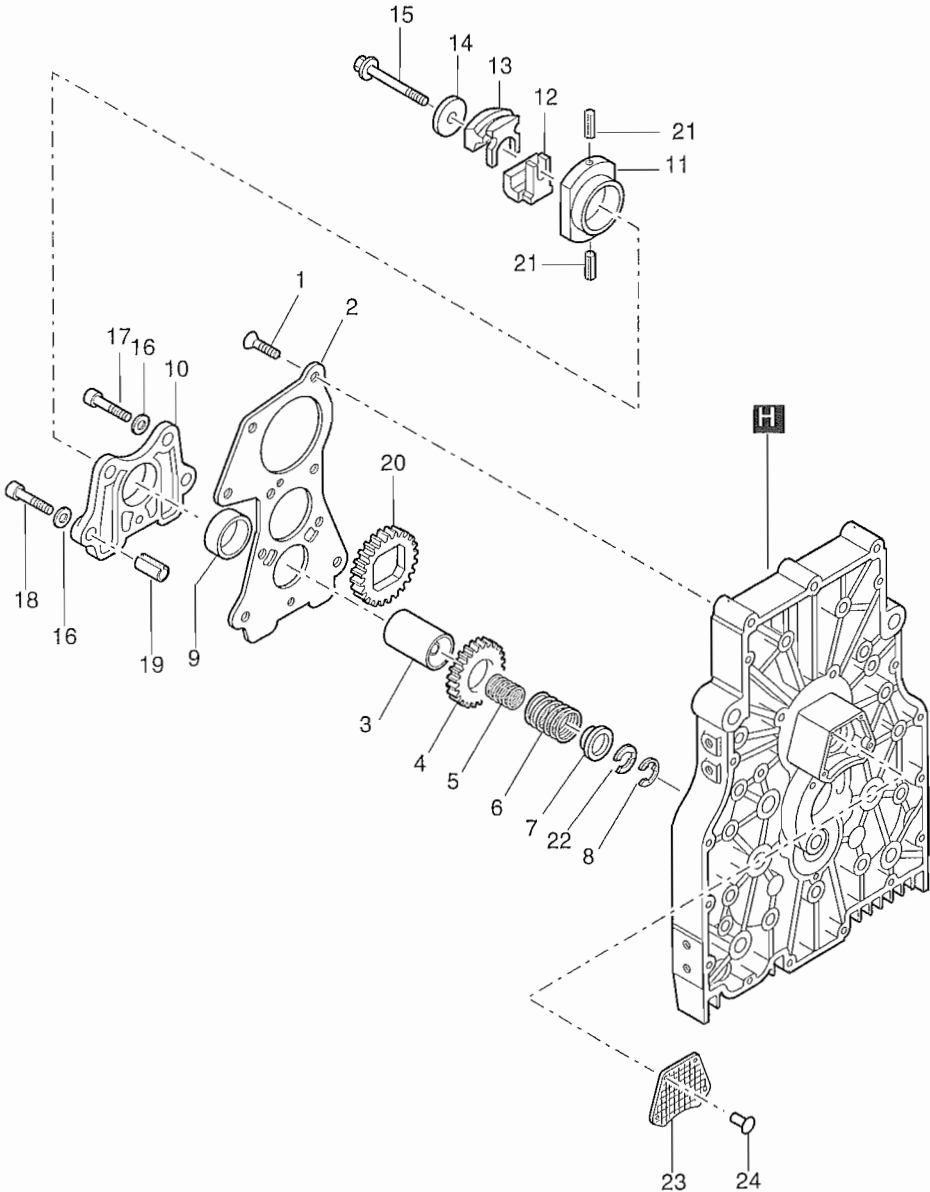

Fig.-No.	HATZ Ident-No.	Stück Qty.	P / W d / D	Bemerkungen Notes
1D90V/W				
1	503 280 00	5		AM 6 x 16 WN 17065
2	037 974 12	1		
3	012 424 01	1		
4	037 973 10	1		
5	040 528 00	1		Ø 1,6 mm ... 1500 min ⁻¹
5	040 529 00	1		Ø 1,7 mm 1501 ... 1800 min ⁻¹
5	040 088 01	1		Ø 1,9 mm 1801 ... 2300 min ⁻¹
6	040 708 00	1		Ø 2,6 mm 2301 ... 2500 min ⁻¹
6	040 634 00	1		Ø 2,9 mm 2301 ... 3000 min ⁻¹
6	040 896 00	1		Ø 2,9 mm 3000 min ⁻¹ Gen.
5	040 088 01	1		Ø 1,9 mm 3001 ... 3600 min ⁻¹ }
6	040 634 00	1		Ø 2,9 mm 3001 ... 3600 min ⁻¹ }
7	037 986 00	1		
8	503 347 00	1	5	DIN 6799
9	037 976 00	1		
10	037 975 10	1		
11	037 977 01	1		
12	037 980 02	1		
13	037 981 02	1		
14	037 979 00	1		
15	037 978 01	1		
16	500 812 00	5	A 6	DIN 137-A3C
17	501 708 00	3	M 6 x 25	DIN 912-8.8
18	500 510 00	2	M 6 x 30	DIN 912-8.8
19	500 849 01	2	8 x 12	DIN 7346
20	037 987 20	1		
21	502 605 01	2	2 x 10	DIN 1481
22	040 460 00	0...3	0,5 mm	
23	041 377 00	1		
24	504 776 00	4	3,2 x 10	

M 11

Steuerdeckel
Timing cover
Couvercle distribution
Tapa de mando
Coperchio distribuzione

Tafel Nr.
Tabl. No.
Tavola N.

11

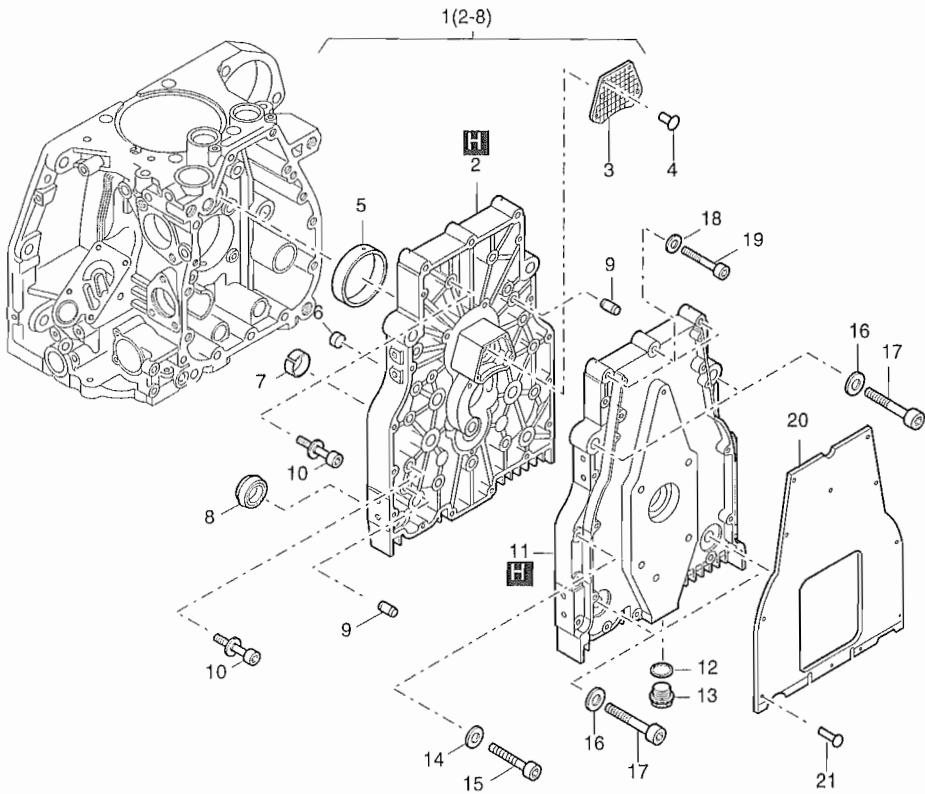

Fig.-No.	HATZ Ident-No.	Stück Qty.	P / W d / D	Bemerkungen Notes
1D90V/W				
1	016 249 00	1		
2	-----	-		
3	041 377 00	1		
4	504 776 00	4		3,2 x 10
5	040 003 10	1		
6	-----	-		
7	037 976 00	1		
8	041 065 00	1		
9	502 491 01	2		8 M 6 x 20 DIN 6325 (2 Fasen)
10	504 174 00	13		M 8 x 30 Z3 DIN 912-8.8
11	041 378 00	1		s. Taf., Tabl. 22 - Pos. 1-4
12	504 591 00	1	D1	22 x 27 DIN 7603-Alu
13	503 731 00	1		AM 22 x 1,5 DIN 7604-A3C magnet.
13	501 404 00	1	W1	AM 22 x 1,5 DIN 7604-A3C f. Ölfilter, Oilfilter
14	500 812 00	14		A 6 DIN 137 A3C
15	503 749 00	14		M 6 x 35 DIN 912-8.8 A3C
16	500 036 00	4		B 12 posph.
17	500 569 00	4		M 12 x 70 DIN 912-10.9
18	500 951 00	3		A 8 DIN 137 A3C
19	501 775 00	3		M 8 x 40 DIN 912-8.8 A3C
20	041 405 00	1		
21	504 776 00	10		2,4 x 6

M 12

Startfüllung
Extra fuel device
Sucharge
Sobre aliment.-arranque
Supplemento

M 14

Einspritzausrüstung
Injection equipment
Equipement d'injection
Equipo de inyección
Equipaggiamento d'iniezione

Tafel Nr.
Tabl. No.
Tavola N.

12

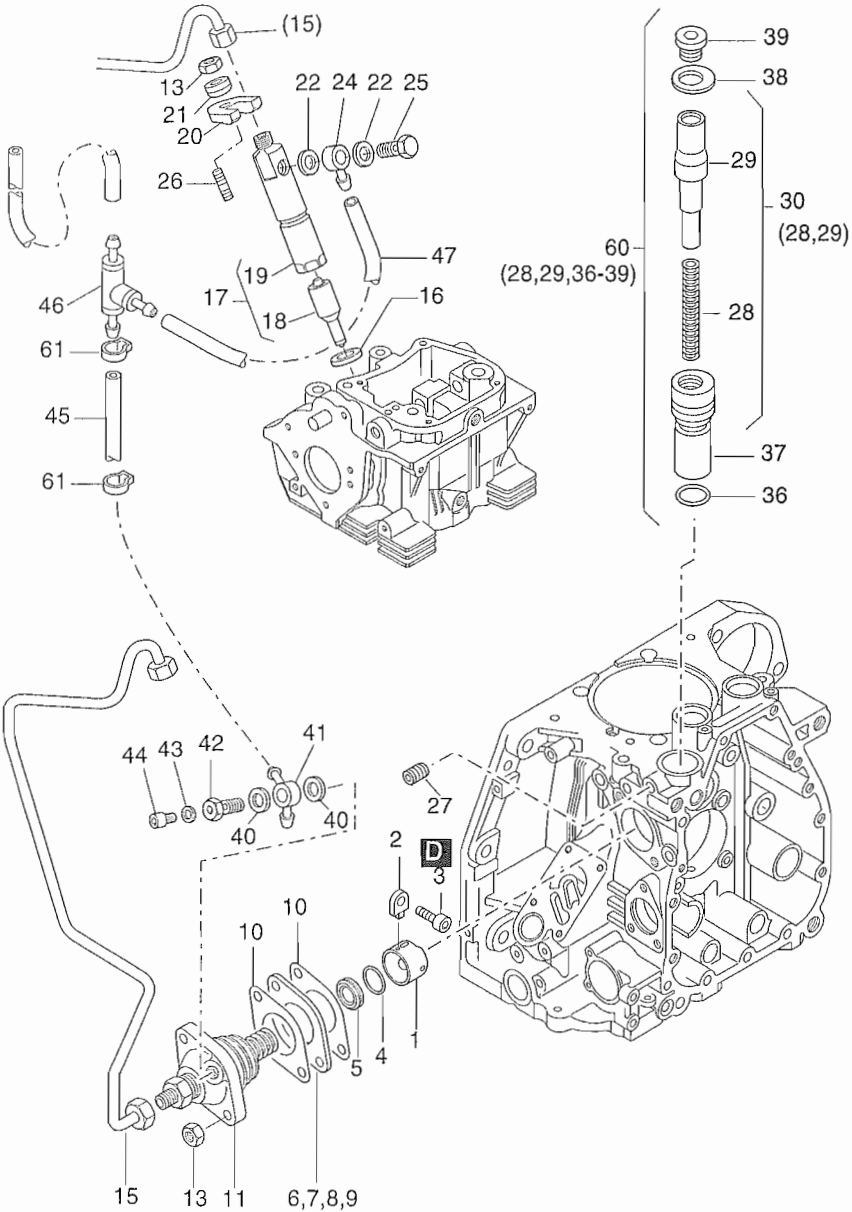

Fig.-No.	HATZ Ident-No.	Stück Qty.	P / W d / D	Bemerkungen Notes
1D90V/W				
1	503 315 01	1		
2	040 009 01	1		
3	500 507 00	1		M 6 x 16 DIN 912-8.8
4	503 902 00	0...1		17 x 1,1
4	503 634 00	0...1	D1	17 x 1,2
5	040 117 00	1		
6	032 097 00	0...1		0,30 mm
7	041 024 00	0...1		0,60 mm
8	041 025 00	0...1		0,90 mm
9	041 026 00	0...1		1,20 mm
10	040 713 00	0...2	D2	0,10 mm
10	041 022 00	0...2		0,20 mm
10	041 023 00	0...2		0,30 mm
11	504 162 00	1		
12	-----	-		
13	501 480 00	3		M 8 DIN 934-8 A3C
14	-----	-		
15	013 136 00	1		
16	040 258 00	1	d1	
17	504 151 01	1		
18	504 152 01	1	P1	
20	037 924 00	1		
21	040 357 00	1		
22	500 008 00	2	d2	A 6,5 x 9,5 DIN 7603-Cu
23	-----	-		
24	503 334 00	1		
25	503 130 00	1		M 6
26	500 384 00	1		M 8 x 35 DIN 835-8.8 A3C
27	500 046 00	1		AM 8 x 16 DIN 916-45H
28	050 352 00	1		
29	-----	-		
30	015 195 00	1		
31	-----	-		
32	-----	-		
33	-----	-		
34	-----	-		
35	-----	-		
36	503 289 00	1	D2	22 x 1,6
37	040 014 10	1		

M 12

Startfüllung
Extra fuel device
Sucharge
Sobre aliment.-arranque
Supplemento

M 14

Einspritzausrüstung
Injection equipment
Equipement d'injection
Equipo de inyección
Equipaggiamento d'iniezione

Tafel Nr.
Tabl. No.
Tavola N.

12

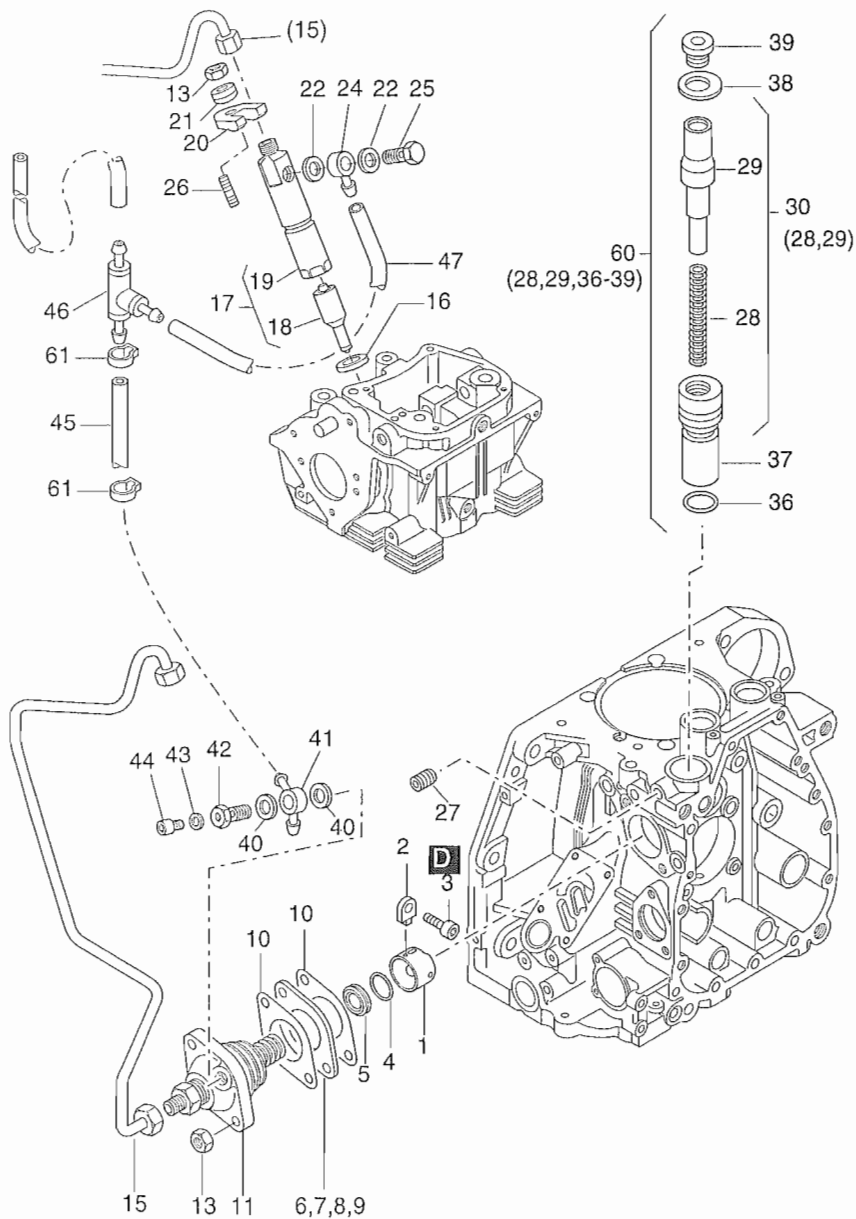

Fig.-No.	HATZ Ident-No.	Stück Qty.	P / W d / D	Bemerkungen Notes
1D90V/W				
38	040 016 00	1		
39	503 308 00	1		M 16 x 1,5 DIN 908-5.8 A3C Tuf.
40	500 011 00	2	D2	A 12 x 15,5 DIN 7603-Cu
41	051 821 00	1		
42	012 232 00	1		
43	500 009 00	1		A 8 x 11,5 DIN 7603-Cu
44	501 379 00	1		M 8 x 1 DIN 7604
45	051 820 00	1		4,5 x 2,5 - 300 mm
46	039 896 00	1		
47	039 621 00	1		3,5 x 2,5 - 160 mm
60	014 989 02	1		
61	503 998 01	2		11,3

M 26

Luftführung
Air duction
Carter ventilation
Conducción de aire
Carter ventilatore

Tafel Nr.
Tabl. No.
Tavola N.

13

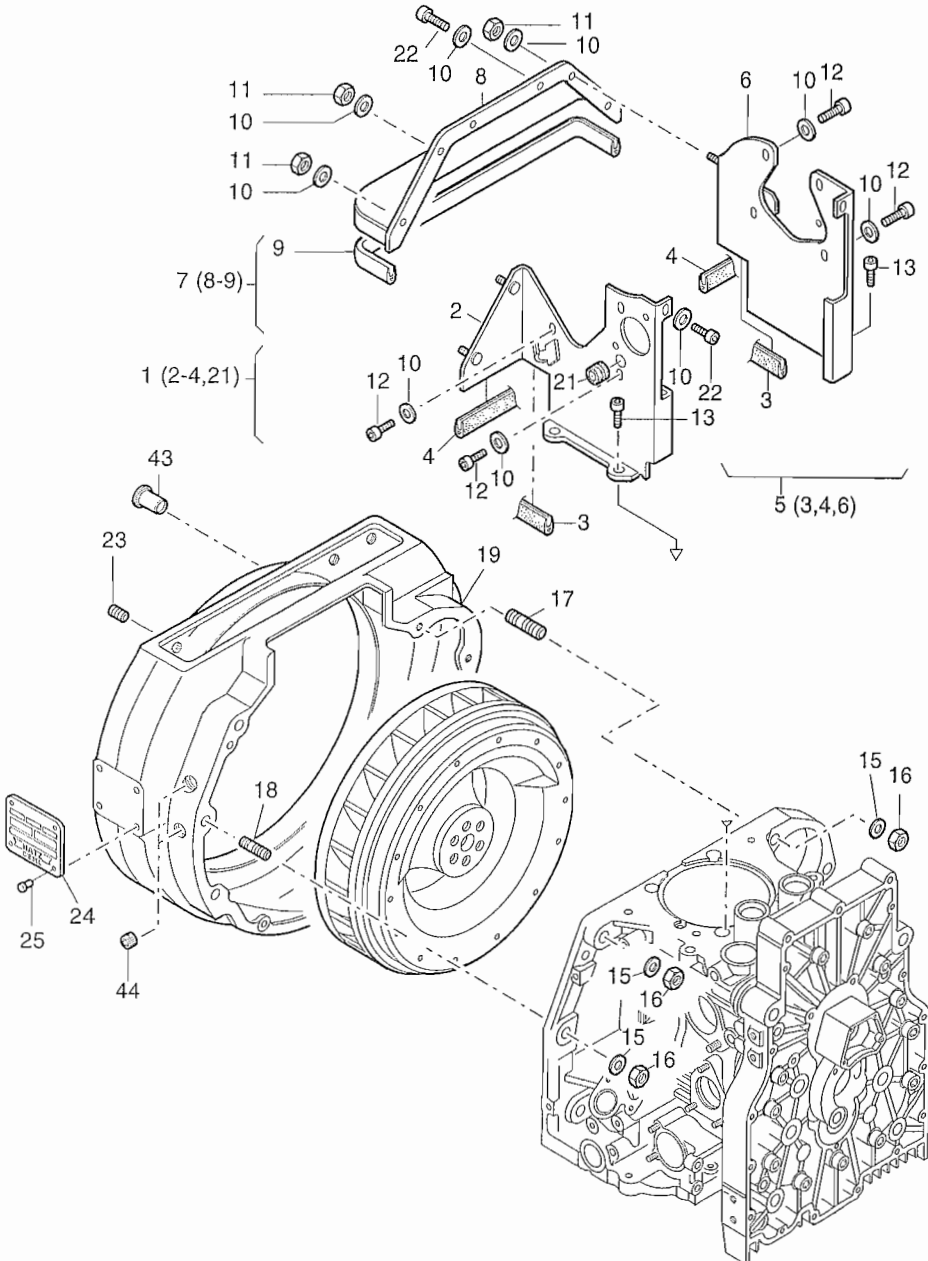

Fig.-No.	HATZ Ident-No.	Stück Qty.	P / W d / D	Bemerkungen Notes
1D90V/W				
1	012 462 20	1		
2	-----	-		
3	040 076 01	2		35 mm
4	040 077 20	2		76 mm
5	012 464 11	1		
6	-----	-		
7	012 466 00	1		
8	-----	-		
9	040 079 01	1		406 mm
10	501 445 00	15		6,4 DIN 125-St A3C
11	501 444 00	4		M 6 DIN 934-8 A3C
12	503 842 00	7		M 6 x 12 DIN 912-8.8 A3C Tuf.
13	502 063 00	4		M 8 x 18 DIN 912-8.8 A3C
15	500 937 00	6		13 DIN 125 -St A3C
16	500 936 00	6		M 12 DIN 934-8 A3C
17	504 750 00	2		M 12 F0 x 40 DIN 835-8.8 A3C
18	504 749 00	4		M 12 F0 x 35 DIN 835-8.8 A3C
19	041 411 00	1		
21	503 348 00	1		
22	501 707 00	4		M 6 x 16 DIN 912-8.8 A3C
23	502 260 00	4		M 8 x 6 DIN 913-45H
24	032 255 04	1		
25	400 025 00	4		2,4 x 6
43	504 216 00	8		12
44	503 956 00	2		M 12 x 1,5 DIN 906 A3C

M 31

Entlüftung
Breather
Purge d'air
Purga de aire
Sfiatatoio

M 32

Drehzahlverstellung
Speed control
Réglage régime
Ajuste de revoluc.
Regolatore di giri

Tafel Nr.
Tabl. No.
Tavola N.

14

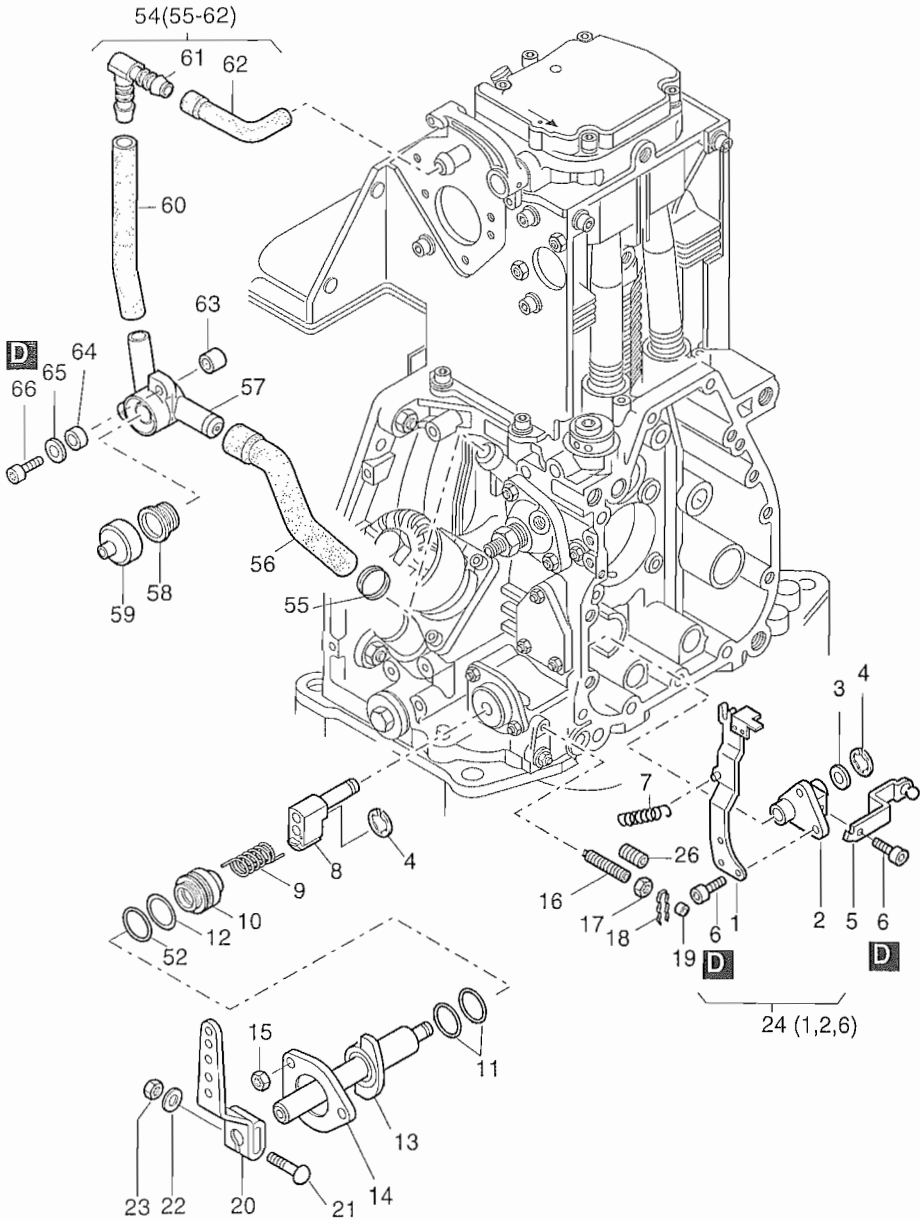

Fig.-No.	HATZ Ident-No.	Stück Qty.	P / W d / D	Bemerkungen Notes
1D90V/W				
1	-----	-		
2	-----	-		
3	040 001 00	1		
4	502 661 00	2		6 DIN 6799
5	040 375 00	1		
6	503 287 01	4		M 5 x 8 DIN 912-8.8 Tuf.
7	040 002 00	1		
8	012 428 10	1		
9	037 990 10	1		
10	040 527 10	1		
11	504 129 00	2	D2	18 x 2
12	501 299 00	1	D1	32 x 2,5
13	012 792 21	1		
14	037 992 10	1		
15	503 283 00	3		VM 6 DIN 980-8 A3C
16	037 994 00	2		
17	501 444 00	2		M 6 DIN 934-8 A3C
18	400 215 00	2		
19	400 214 00	2		
20	038 883 00	1		
21	039 273 00	1		M 6 x 32
22	501 445 00	1		6,4 DIN 125-St A3C
23	501 444 00	1		M 6 DIN 934-8 A3C
24	012 468 01	1		
25	-----	-		
26	504 035 00	1		M 8 x 20 DIN 914-45 H
52	504 536 00	1		32 x 45 x 2,5 DIN 988 A3C
53	-----	-		
54	013 404 00	1		
55	040 905 00	1		
56	041 409 00	1		
57	-----	-		
58	035 687 00	1		
59	041 407 00	1		
60	041 694 00	1		11 x 16 x 160
61	504 772 00	1		WS 10-90°
62	041 408 00	1		
63	041 410 00	1		6,1 x 15 x 20
64	040 805 00	1		7 x 8 x 8
65	501 445 00	1		6,4 DIN 125-St A3C
66	503 749 00	1		M 6 x 35 DIN 912-8.8 A3C

A 01

Kraftstoffbehälter, Filter, Leitungen
Fuel tank, filter, pipes
Reservoir à carburant, filtre, conduites
Depósito combustible, filtro, tubería
Serbatoio combustibile

Tafel Nr.
Tabl. No.
Tavola N.

15

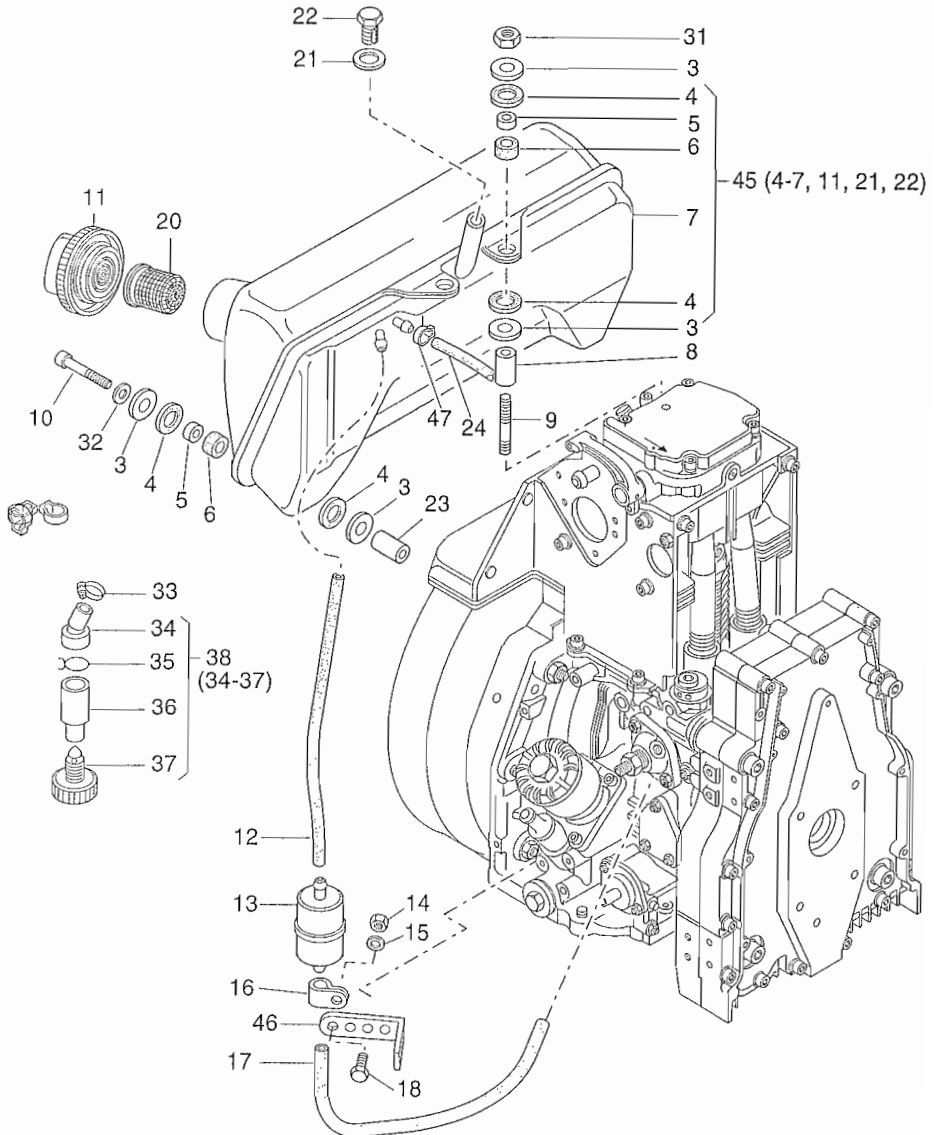

Fig.-No.	HATZ Ident-No.	Stück Qty.	P / W d / D	Bemerkungen Notes
1D90V/W				
3	050 976 00	12		
4	039 818 02	12		15 - 25
5	039 817 01	6		8,4 x 13 x 7,5
6	039 819 00	6		
7	-----	-		
8	039 898 00	2		8,5 x 20 x 49
9	503 770 01	2		M 8 x 75 DIN 835-10.9 A3C
10	501 775 00	4		M 8 x 40 DIN 912-8.8 A3C
11	503 858 01	1	P1	
12	038 051 00	1		7 x 250
13	504 788 00	1	W2	
14	501 444 00	1		M 6 DIN 934-8
15	501 445 00	1		6,4 DIN 125-St A3C
16	501 584 00	1		
17	036 743 00	1		7 x 305 mm
18	501 655 00	1		M 6 x 12 DIN 933-8.8 A3C
20	503 873 00	1		
21	500 010 00	1		A 10 x 16 DIN 7603-Cu
22	051 260 00	1		M 10 x 12
23	050 292 00	4		9 x 18 x 8
24	051 819 00	1		4,5 x 40 mm
31	501 480 00	2		M 8 DIN 934-8 A3C
32	502 085 00	4		8 DIN 128-St A3C
33	504 480 00	1		
34	050 440 01	1		
35	050 369 00	1		28 mm
36	050 439 00	1		
37	504 148 00	1		M 10
38	015 194 01	1		
45	016 265 00	1		7 l
45	016 266 00	1		10 l
46	051 183 00	1		
47	503 998 01	1		11,3

A 01

Förderpumpe
Fuel feed pump
Pompe alimentation
Bomba alimentacion
Pompa A.C.

Tafel Nr.
Tabl. No.
Tavola N.

16

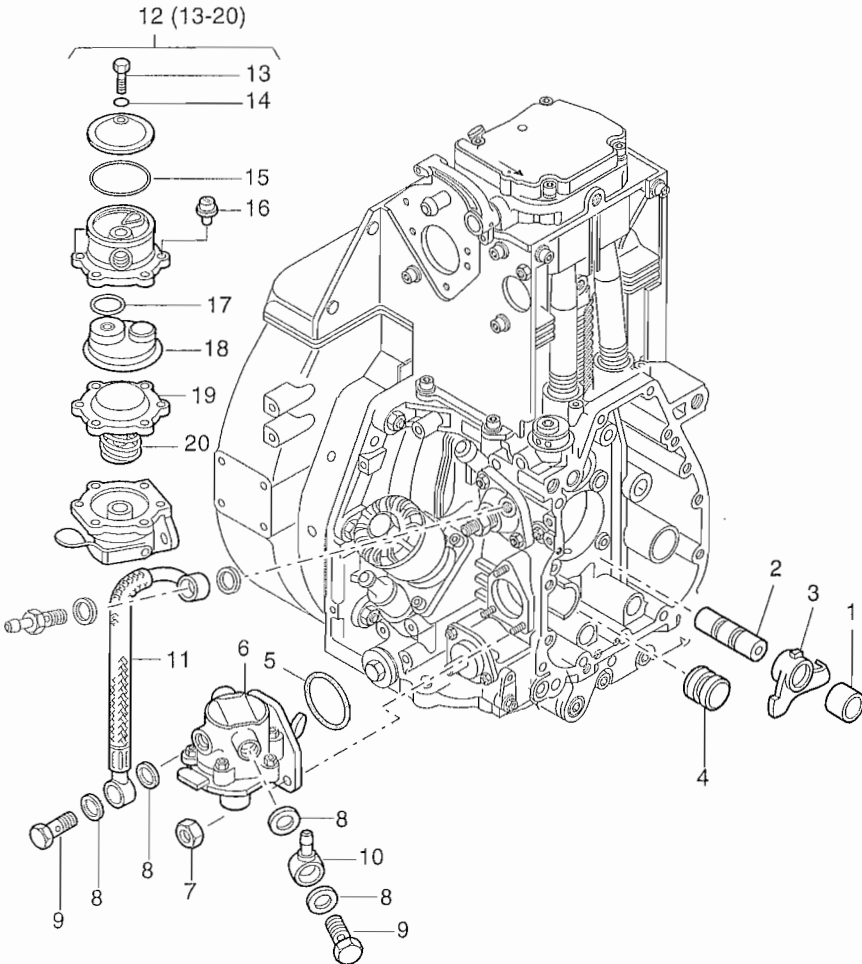

Fig.-No.	HATZ Ident-No.	Stück Qty.	P / W d / D	Bemerkungen Notes
1D90V/W				
1	040 119 00	1		„V“ 15 x 24 x 17
2	037 964 01	1		„V“
3	040 118 10	1		
4	040 008 00	1		
5	503 318 00	1	D1	35 x 2,8
6	503 323 02	1		
7	503 283 00	3		VM6 980-8 A3C
8	500 012 00	4		A 14 x 18 DIN 7603-Cu
9	500 064 00	2		10-3 DIN 7643
10	500 159 00	1		NW 8/6
11	014 688 01	1		
12	490 625 01	1		Reparatursatz, repair kit
13	-----	-		
14	-----	-		
15	503 995 00	1		37 x 2,5
16	-----	-		
17	-----	-		
18	-----	-		
19	-----	-		
20	-----	-		

A 02

Luftfilter
 Air filter
 Filtre à air
 Filtro de aire
 Filtro aria

Tafel Nr.
 Tabl. No.
 Tavola N.

17

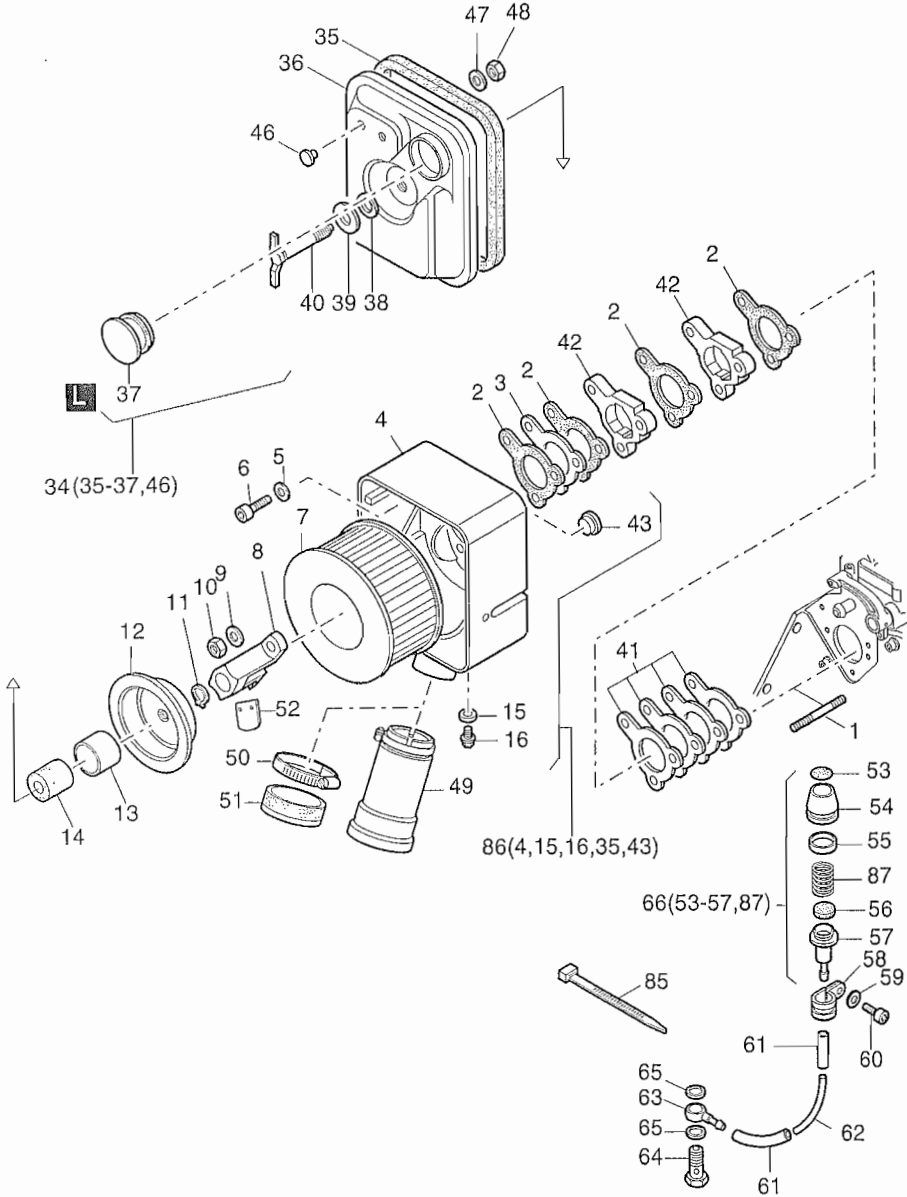

Fig.-No.	HATZ Ident-No.	Stück Qty.	P / W d / D	Bemerkungen Notes
1D90V/W				
1	500 391 00	2		M 8 x 70 DIN 835-8.8
2	040 063 00	4	d4	
3	040 062 00	1		
4	-----	-		s. Pos. 86
5	500 951 00	1		A 8 DIN 137 A3C
6	504 785 00	1		M 8 x 55 DIN 6912-8.8 A3C
7	014 930 00	1	W2	
8	014 834 00	1		
9	501 481 00	2		8,4 DIN 125-St A3C
10	501 295 00	2		M 8 DIN 985-8 A3C
11	504 120 00	1		A 10 x 1 DIN 471
12	050 364 00	1		
13	050 393 00	1		33 x 35 x 23,5
14	035 794 00	1		
15	500 624 00	1		A 10 x 13,5 DIN 7603-Cu
16	500 623 00	1		M 10 x 1 DIN 908-5.8 A3C
34	014 968 00	1		
35	040 477 01	1		705 mm
36	-----	-		
37	050 394 02	1		
38	038 141 00	1		
39	050 387 00	1		11 x 36 x 3
40	014 908 00	1		
41	012 879 00	1		
42	040 473 00	2		
43	503 957 00	1		15 PHT
46	504 119 00	2		F2
47	501 200 00	2		A 6,4 DIN 9021-St A3C
48	400 283 00	2		M 6 C 3 P SSN 440-8
49	014 110 00	1		
50	504 066 00	1		40/60
51	005 759 00	1		
52	050 335 00	1		
53	050 445 01	1		
54	050 436 01	1		
55	050 456 00	1		grün, green,vert, verde
56	051 372 00	1		Filter

A 02

Luftfilter
Air filter
Filtre à air
Filtro de aire
Filtro aria

Tafel Nr.
Tabl. No.
Tavola N.

17

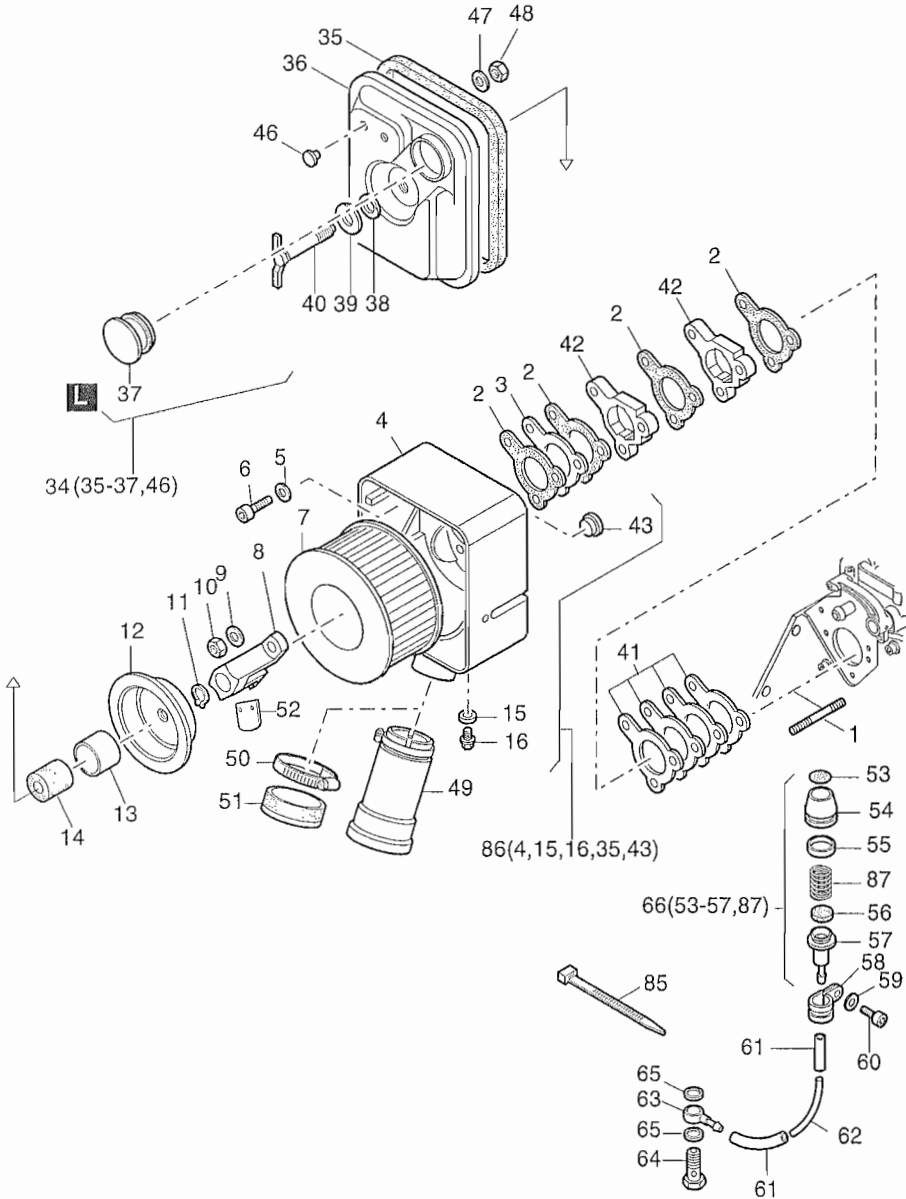

Fig.-No.	HATZ Ident-No.	Stück Qty.	P / W d / D	Bemerkungen Notes
1D90V/W				
57	050 437 00	1		
58	501 735 00	1		10/15
59	501 709 00	1		6 DIN 128 A3C
60	501 706 00	1		M 6 x 20 DIN 912-8.8 A3C
61	039 614 00	2		3,5 x 50
62	050 446 10	1		2 x 4 x 135
63	501 595 00	1		NW 4/3
64	500 062 00	1		6-3 DIN7643
65	500 624 00	2		A 10 x 13,5 DIN 7603-Cu
66	016 385 00	1		(Pos. 53, 54, 55, 56, 57, 87)
85	503 584 00	1		
86	014 866 00	1		(Pos. 4, 15, 16, 35, 43)
87	051 611 00	1		

A 03

Abgasdämpfer
Exhaust silencer
Silencieux
Silenciador
Marmitta

Tafel Nr.
Tabl. No.
Tavola N.

18

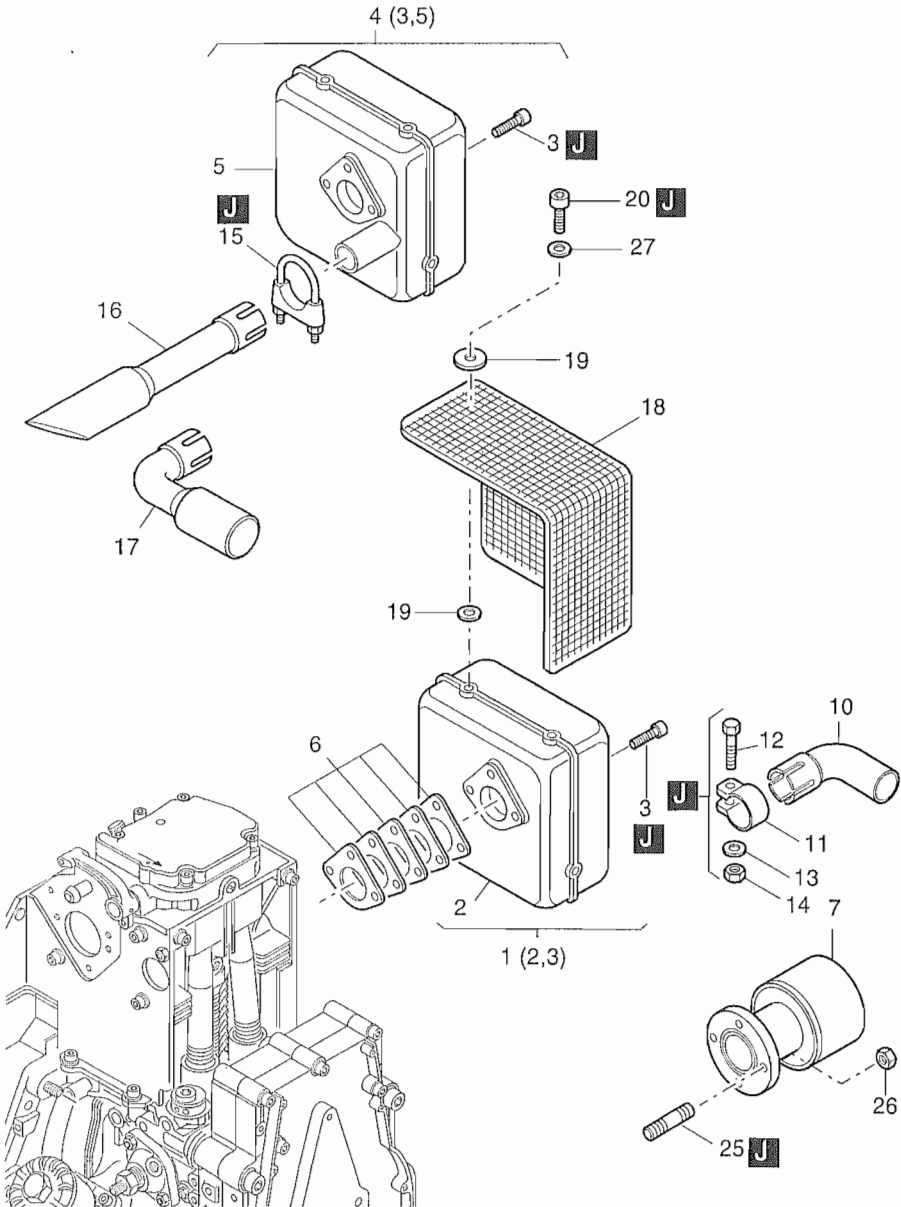

Fig.-No.	HATZ Ident-No.	Stück Qty.	P / W d / D	Bemerkungen Notes
1D90V/W				
1	014 988 00	1		
2	-----	-		
3	504 040 00	3		M 8 x 30 DIN 912-8.8 C4P
4	015 075 00	1		
5	-----	-		
6	014 291 00	1	d1	
7	015 009 00	1		
10	038 773 00	1		
11	038 777 00	1		52,5 mm
12	502 495 00	1		M 10 x 50 DIN 931-8.8 A3C
13	501 459 00	1		10,5 DIN 125-St A3C
14	400 286 00	1		VM 10 DIN 980-8 C3A
15	503 881 00	1		3/8-36
16	039 971 01	1		
17	039 970 00	1		
18	011 919 02	1		
19	050 342 00	10		6,5 x 38
20	502 557 00	5		M 6 x 12 DIN 912-8.8 C4P
25	500 373 00	2		M 8 x 18 DIN 835-10.9
26	400 284 00	2		VM 8 DIN 980-8 C3A
27	501 200 00	5		A 6,4 DIN 9021-St A3C

A 05

Starter, Generator
Starter, alternator
Démarreur, alternateur
Arrancador, alternador
Motorino avviamento, alternatore

Tafel Nr.
Tabl. No.
Tavola N.

19

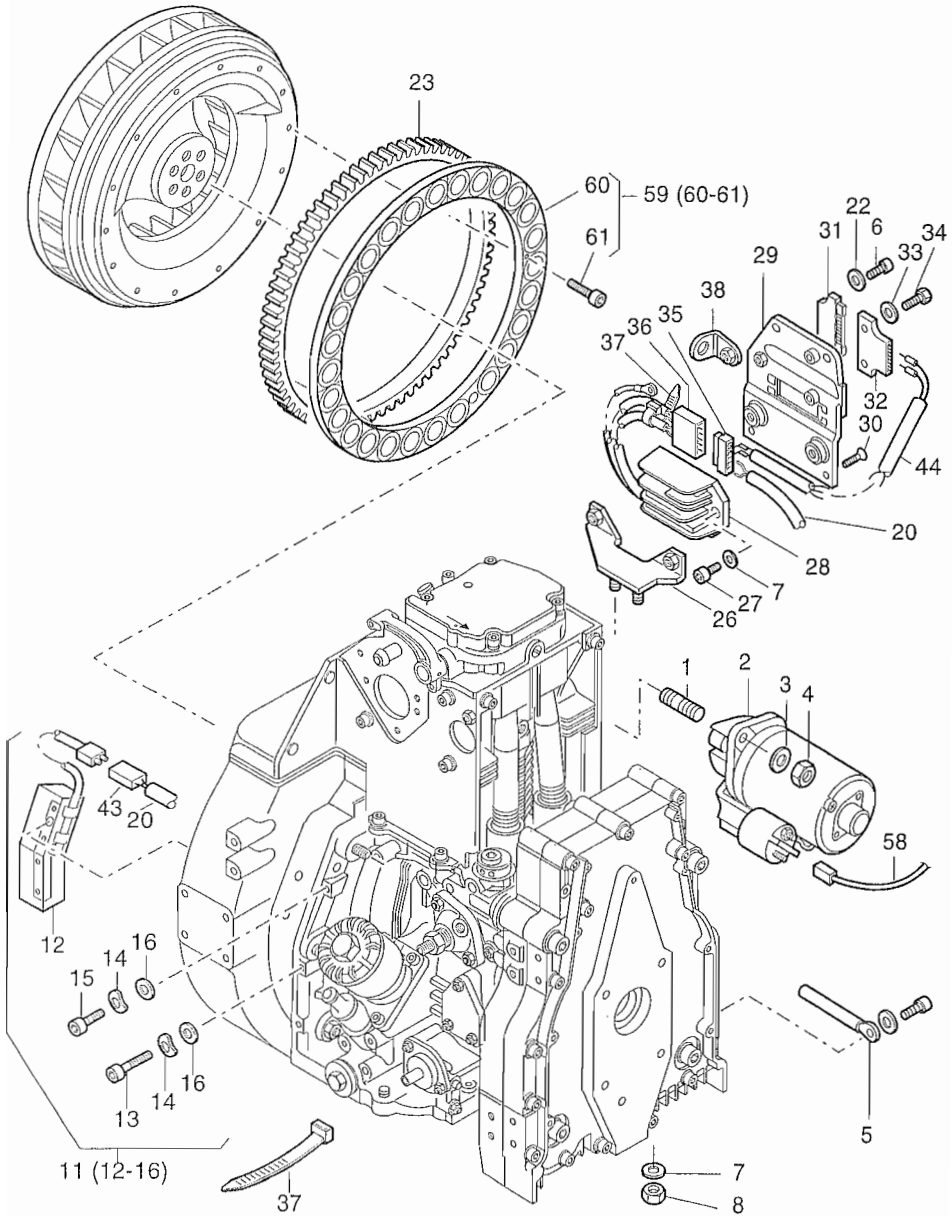

Fig.-No.	HATZ Ident-No.	Stück Qty.	P / W d / D	Bemerkungen Notes
1D90V/W				
1	502 012 00	2		M 12 x 50 DIN 835-8.8 A3C
2	016 684 00	1		12 V - 1,5 kW
3	500 937 00	2		13 DIN 125-St A3C
4	503 806 00	2		M 12 DIN 970 A3C
5	014 597 00	4		
6	501 491 00	1		M 6 x 12 DIN 912-8.8 A3C
7	502 085 00	4		8 DIN 128 A3C
8	501 480 00	2		M 8 DIN 934-8 A3C
11	015 924 00	1		12 V
12	-----	-		
13	504 488 00	1		M 6 x 40 DIN 6912-8.8 A3C
14	501 656 00	2		6,5 x 14 DIN 6904 A3C
15	504 487 00	1		M 6 x 30 DIN 6912-8.8 A3C
16	501 445 00	2		6,4 DIN 125-St A3C
20	014 628 00	1		
22	501 709 00	6		6 DIN 129 A3C
23	040 212 10	1		
26	014 403 01	1		
27	501 654 00	2		M 8 x 16 DIN 912-8.8 A3C
28	012 481 22	1		12 V
29	014 401 00	1		
30	503 808 00	2		M 6 x 10 DIN 7991-8.8 A3C
31	503 737 00	1		
32	503 736 00	1		
33	502 163 00	2		5,3 DIN 125-St A3C
34	503 357 00	2		M 5 x 25 DIN 933-8.8 A3C
35	504 021 00	1		
36	504 020 00	1		
37	503 584 00	4		
38	014 402 00	1		
43	503 797 00	1		
44	014 394 00	1		Pos. 35 incl.
58	011 934 01	1		Starter 50
59	015 873 00	1		Magnetring kpl.
60	-----	-		
61	504 469 00	14		M 4 x 16 DIN 912-8.8 A3C Tuf.

A 05

Armaturenkasten 12V - 1D90V/W
 Instrument box 12V - 1D90V/W
 Boitiere de bord 12V - 1D90V/W
 Cuadro de mando 12V - 1D90V/W
 Cruscotto 12V - 1D90V/W

Tafel Nr.
 Tabl. No.
 Tavola N.

20

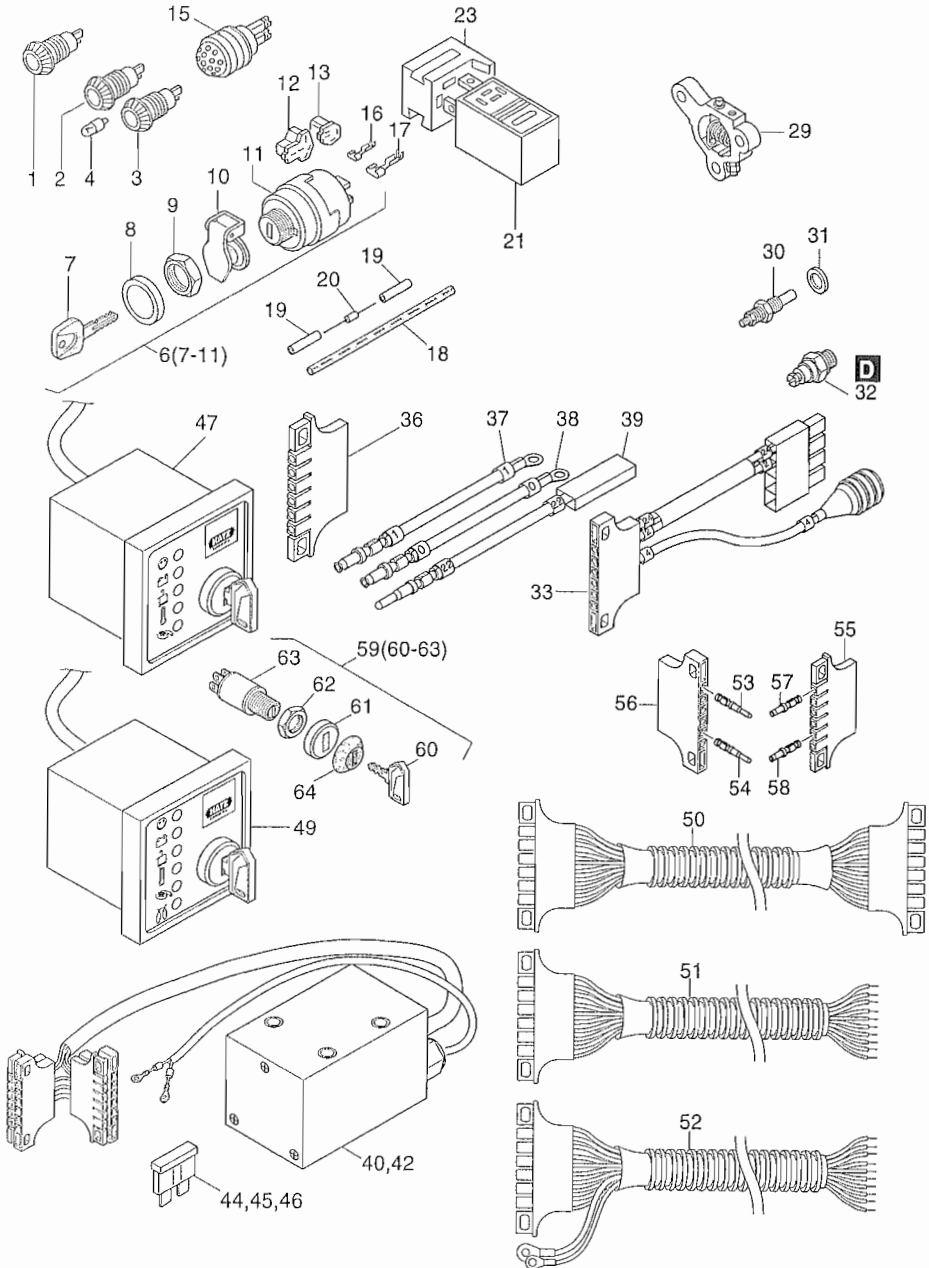

Fig.-No.	HATZ Ident-No.	Stück Qty.	P / W d / D	Bemerkungen Notes
1D90V/W				
1	50176500	1		BATT.
2	50176400	1		TEMP.
3	50176600	1		OIL
4	40009700	0...3		12 V - 2 W
6	50276502	1		
7	50345300	1		14603
8	-----	-		
9	-----	-		
10	49050900	1		
11	-----	-		
12	50276700	1		6 - P
13	50276600	1		4 - P
15	50397200	1		12 - 24 V
16	40074700	5		B 6,3 - 2,5 BZ
17	50276800	4		9,5 - 6A
18	03670000	2		4 x 120 mm
19	50189200	4		
20	50344400	2		DIODE
21	50275802	0...1		12 V HATZ MSR
23	50276000	1		
29	01275500	1		12 - 24 V
30	50268600	1		TEMP.
31	05162400	1		10,4 x 14 x 4
32	50272200	1		OIL
33	01403620	1		

A 05

Armaturenkasten 12V - 1D90V/W
Instrument box 12V - 1D90V/W
Boîtier de bord 12V - 1D90V/W
Cuadro de mando 12V - 1D90V/W
Cruscotto 12V - 1D90V/W

Tafel Nr.
Tabl. No.
Tavola N.

20

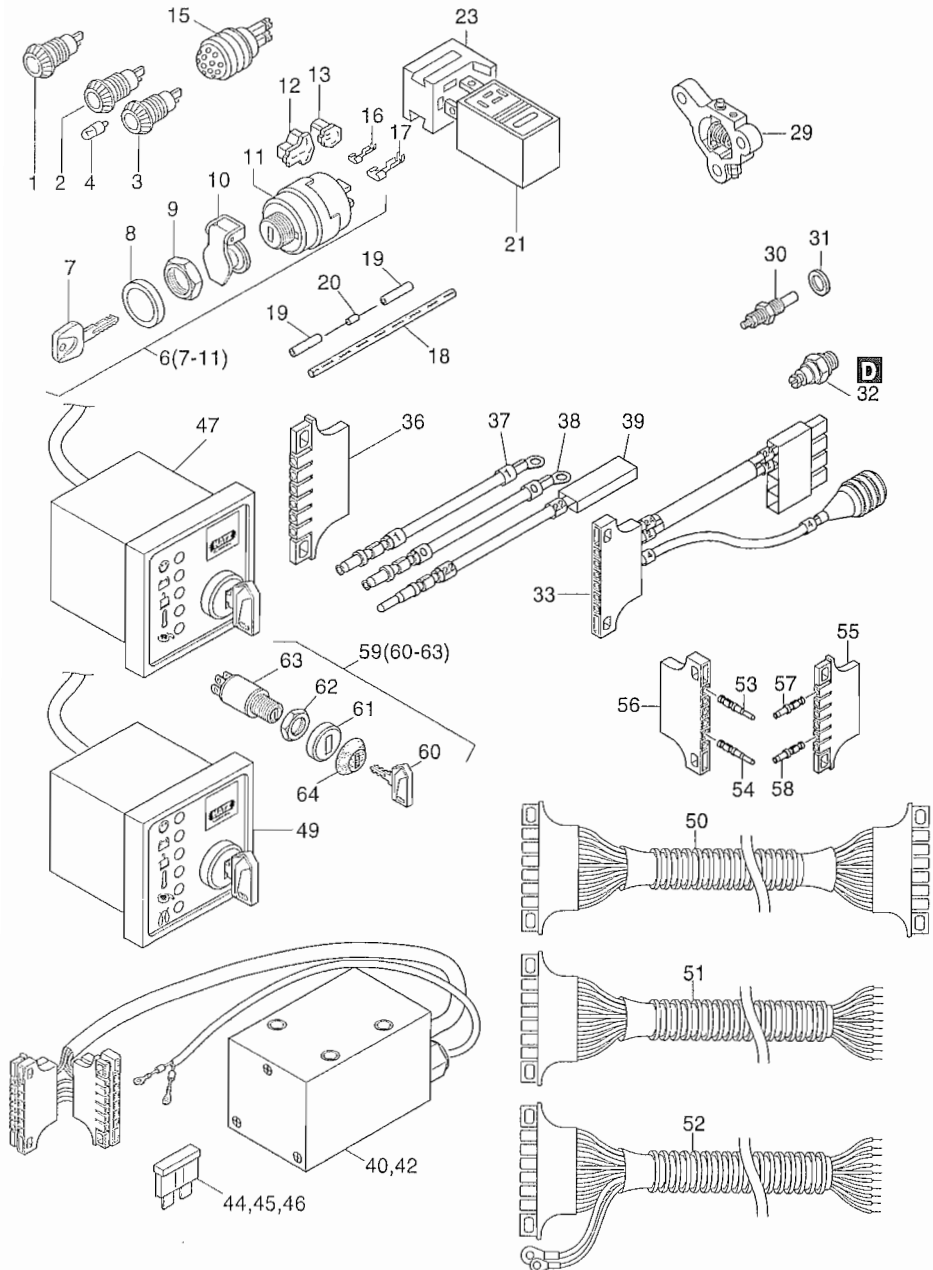

Fig.-No.	HATZ Ident-No.	Stück Qty.	P / W d / D	Bemerkungen Notes
1D90V/W				
36	50373700	1		
37	01574300	1		(1)
38	01574401	1		(0)
39	01526800	1		(22)
40	01589300	1		12 V Powerbox II
42	01591000	1		12 V Powerbox III
44	50459300	1		10 A
45	50430700	1		30 A
46	50433000	2		40 A
47	01551802	1		12 V, A 1
49	01558901	1		12 V / 24 V, A 2
50	01611200	1		K 1 - 2 m
51	01549801	1		K 2 - 2 m
52	01192710	1		K 3 - 2 m
53	50374300	1		2,5 - 4,0
54	50374100	5		0,5 - 1,0
55	50373700	1		
56	50373600	1		
57	50373800	5		0,5 - 1,0
58	50373900	1		1,5 - 2,5
59	50384401	1		
60	50404900	1		14644
61	-----	-		
62	-----	-		
63	-----	-		
64	05126402	1		

A 09

Abstellvorrichtung
Stop device
Dispositiv d'arret
Dispos. desconectad
Leva stopi

A 11

Hubmagnet
Lifting magnet
Electro aimont
Elevador megn.
Magnete stop

Tafel Nr.
Tabl. No.
Tavola N.

21

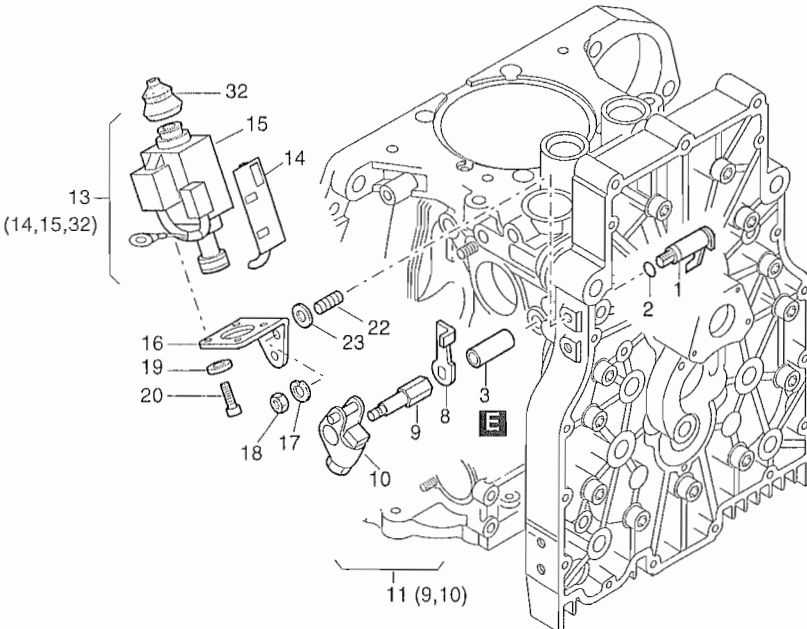
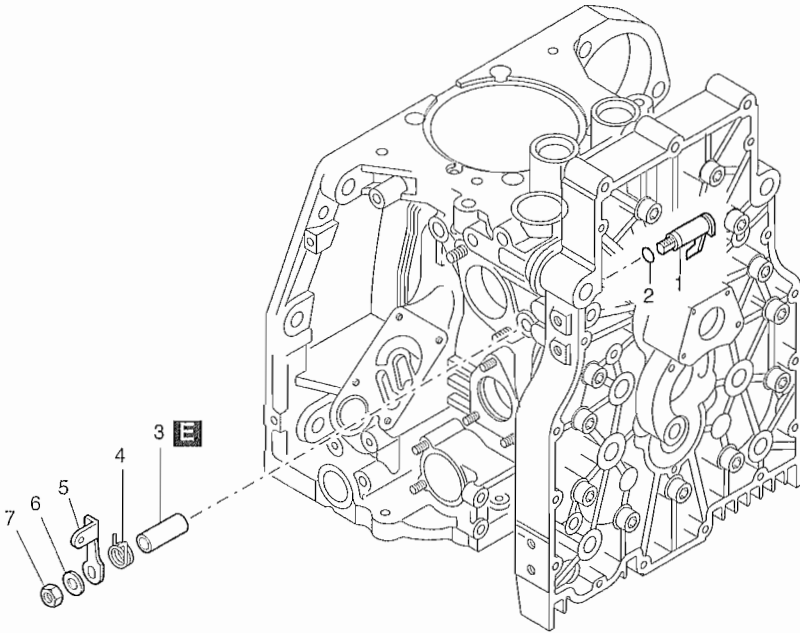

Fig.-No.	HATZ Ident-No.	Stück Qty.	P / W d / D	Bemerkungen Notes
1D90V/W				
1	012 546 02	1		
2	503 433 00	1		4,6 x 1,85
3	040 214 00	1		
4	040 218 00	1		
5	040 217 00	1		
6	501 445 00	1		6,4 DIN 125-St A3C
7	503 283 00	1		VM 6 DIN 980-8 A3C
8	050 151 01	1		
9	-----	-		
10	014 931 10	1		
11	015 153 00	1		
12	-----	-		
13	015 155 00	1		12 V
14	050 584 00	1		
15	-----	-		
16	050 235 01	1		
17	501 709 00	2		6 DIN 128 A3C
18	501 444 00	2		M 6 DIN 934-8 A3C
19	502 163 00	3		5,3 DIN 125-St A3C
20	501 126 00	4		M 5 x 10 DIN 6912-8.8 A3C
21	-----	-		
22	503 668 00	2		M 6 x 12 DIN 835-8.8 A3C
23	501 143 00	2		6,4 DIN 7349 A3C
32	502 489 00	1		

A 18

Anbauteile Hydraulikpumpe
Mount. parts hydr. pump
Pièces mont.-pompe hydr.
Piezas mont. bomba hidr.
Particorari per montaggio pompa idraulica

Tafel Nr.
Tabl. No.
Tavola N.

22

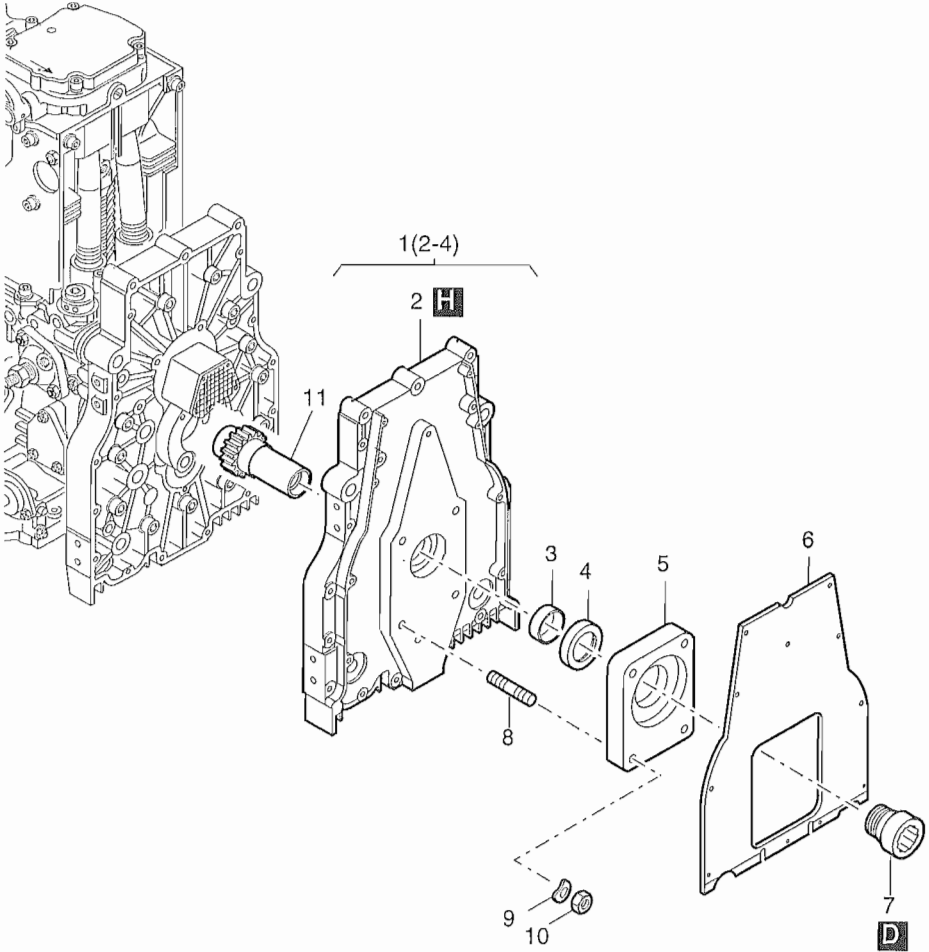

Fig.-No.	HATZ Ident-No.	Stück Qty.	P / W d / D	Bemerkungen Notes
1D90V/W				
1	016 248 00	1		
2	-----	-		
3	040 232 10	1		
4	503 647 00	1	D1	32 x 52 x 7
5	041 421 00	1		
6	041 405 00	1		
7	051 009 00	1		
8	502 792 00	4		M 8 x 40 DIN 835-8.8 A3C
9	500 951 00	4		A 8 DIN 137 A3C
10	501 480 00	4		M 8 DIN 934-8 A3C
11	041 418 00	1		

