



MOTORENFABRIK HATZ • D-94099 Ruhstorf • Germany
 Tel.: 0 85 31 / 319-0 • Telex: 57260 • Telefax: 0 85 31 / 31 94 18

Ersatzteil-Liste
Spare parts list
Liste des pièces de rechange
Lista de recambios
Catalogo ricambi



1D20.

1D30.

1D40.

A1D35.

A1D40.

1D60.

1D80.

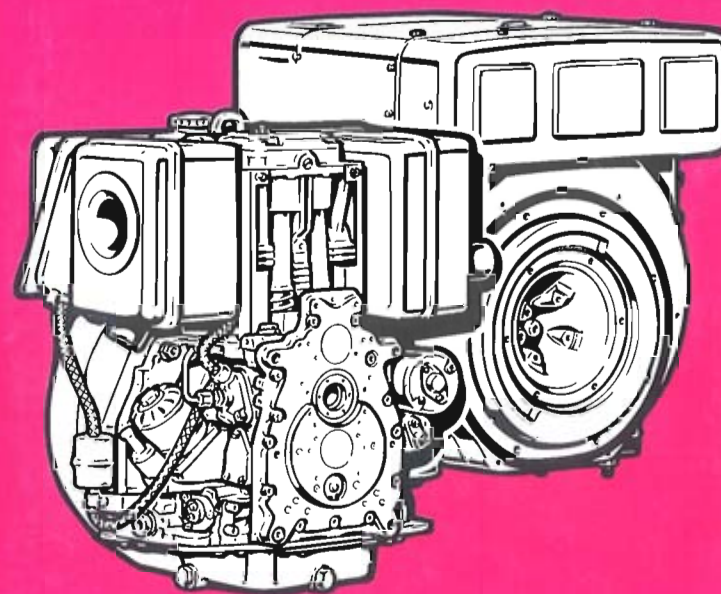

34/556 -1.94 - 5
 Printed in Germany

Schutzgebühr DM 3.-
 Protection tax
 Taxe de protection
 Derecho de protección
 Tassa di protezione

- No. 1D20.10
- No. 1D30.13
- No. 1D40.14
- No. A1D35.12
- No. A1D40.11
- No. 1D60.17
- No. 1D80.17

WICHTIG - Bitte Daten eintragen
IMPORTANT - Compléter les données
IMPORTANTE - Completare i dati

IMPORTANT - Please enter data
IMPORTANTE - Favor completar datos

Bitte hier Typ, Motornummer und Drehzahl (siehe Motor-Typenschild) eintragen.

Enter here type engine no. and rpm. (see engine type-plate).

Indiquer ici le type, N° de moteur et régime (voir plaque signalétique).

Insertar aquí tipo- N° motor y r.p.m. (vea placa del motor).

Indicare qui il tipo del motore, la matricola e il regime (vedi targhetta)

⊕ MOTORENFABRIK HATZ <small>GMH</small> KG ⊕			
D-94099 RUHSTORF			
TYP	KENNZ.		
MOTOR/FABRIK NO.		ABE/AUSE.	
MIN ¹	NH	PV	CM ³
HATZ			
DIESEL			
MADE IN GERMANY			
⊕			

Ersatzteilliste Nr.

Spare parts list no.

Liste des pièces de rechange no.

Lista de recambios no.

Catalogo ricambi n.

- | | |
|--|--|
| <input type="checkbox"/> 1D20.10 | <input type="checkbox"/> 1D30.13 |
| <input type="checkbox"/> A1D35.12 | <input type="checkbox"/> A1D40.11 |
| <input type="checkbox"/> 1D40.14 | <input type="checkbox"/> 1D60.17 |
| <input type="checkbox"/> 1D80.17 | |

Bitte tragen Sie hier die Anschrift Ihrer nächsten HATZ-Servicestelle ein.

Insert here address of your next HATZ Service station.

Indiquer ici l'adresse de votre station service HATZ la plus proche.

Insertar aquí dirección de servicio HATZ más cercano.

Indicare qui l'indirizzo dell'officina HATZ a voi più vicina.

HATZ-Service

MOTORENFABRIK HATZ
D-94099 RUHSTORF • Germany

Angaben bei Ersatzteilbestellungen:

Zur richtigen und schnellen Belieferung mit Ersatzteilen sind folgende Angaben erforderlich:

1. **Type, Motornummer und Drehzahl** des Motors, für den das Ersatzteil benötigt wird: siehe Angaben auf Seite 1.
2. **Nummer der Ersatzteilliste**, aus der die Bestellnummer herausgelesen wurde: siehe Seite 1.
3. **Stückzahl und Bestell-Nr.** des gewünschten Ersatzteils
4. Gewünschte **Versandart**, z.B. Post, Luftfracht, Express.
5. Genaue **Versandadresse**, wenn erforderlich mit Post- und Bahnstation.

Bestellbeispiel:

Für Motortype: 1 D 60 - 151a
 Motornummer: 891793002597
 min⁻¹: 3000/60

aus Ersatzteilliste: 1 D 60.17
folgende Teile:

Stück	Bestell-Nr.
2	500 526 00
8	500 812 00

per Postexpress an....

Die Ersatzteilbestellung richten Sie bitte an:

– die nächste HATZ-Servicestelle, Anschrift siehe Seite 1, oder separates Servicestellenverzeichnis

– oder an die

Motorenfabrik HATZ GmbH & Co. KG
 D - 94099 Ruhstorf
 Germany
 Tel. 08531 / 319-0
 Telex 57260
 Telefax 08531 / 319 418

Particulars for spare parts orders:

The following information is needed to ensure correct and prompt supply of spare parts:

1. **Engine type, engine number and r.p.m.** of the engine for which you need the spare part.
See particulars on page 1.
2. **Number of spare parts list** from which you took the ordering no., see page 1.
3. **Quantity and ordering no.** of requested spare part.
4. Requested **mode of dispatch**, e.g. surface/airmail, airfreight, express.
5. Exact **shipping address**, if necessary indicate local post office and/or railway station.

Example for your order:

For engine type 1 D 60 - 151a
 Engine number 891793002597
 R.p.m. 3000/60

Spare parts list no. 1 D 60.17

The following parts:

Qty.	ordering-no.
2	500 526 00
8	500 812 00

to be mailed, express, to...

Please address your spare parts order to:

– your nearest HATZ service station, address see page 1, or separate HATZ-service-list

– or to

Motorenfabrik HATZ GmbH & Co. KG
 D - 94099 Ruhstorf
 Germany
 Tel. 08531 / 319-0
 Telex 57260
 Telefax 08531 / 319 418

Données à indiquer lors de vos commandes de pièces détachées:

Pour nous permettre de livrer vos pièces rapidement et correctement, nous avons besoin des données suivantes:

1. **Type, No. et régime du moteur** pour lequel vous avez besoin de pièces: voir données page 1.
2. **No de la liste de pièces de rechange** dans laquelle figure le No. de commande voir page 1.
3. **Quantité et No. de commande** de la pièce souhaitée.
4. **Mode d'expédition** souhaitée: par ex. par poste, frêt aérien, exprès.
5. **Adresse exacte de destination** et, lorsque ceci est nécessaire, le nom de la poste et de la gare, ou aéroport.

Exemple:

Pour type de moteur: 1 D 60 - 151a
No. moteur: 891793002597
Régime: 3000/60
Liste de pièces de rechange: 1 D 60.17
Les pièces suivantes:
Qté. No. commande
2 500 526 00
8 500 812 00
Par poste exprès à...

Les commandes de pièces détachées sont à adresser à:

- votre station-service HATZ la plus proche, voir adresse page 1, ou liste en service séparée.

- ou

Motorenfabrik HATZ GmbH & Co. KG
D - 94099 Ruhstorf
Allemagne
Tel. 08531 / 319-0
Telex 57260
Telefax 08531 / 319 418

Datos para pedidos de recambios:

Para recibir sus recambios en forma rápida y correcta necesitamos las siguientes informaciones:

1. **Tipo, número del motor y revoluciones:** ver detalles en página 1.
2. **Número de la lista de recambios** de la cual se ha obtenido el número de pedido: ver página 1.
3. **Cantidad y número de pedido** del recambio deseado.
4. Tipo de **despacho deseado:** por ej. correo, fiete aereo, expreso etc.
5. **Dirección** exacta, si necesario indicar la oficina de correo, la estación ferrocarril o aeropuerto.

Ejemplo de pedido:

Para motor tipo: 1 D 60 - 151a
Número de motor: 891793002597
R.P.M. 3000/60
De la lista de recambios: 1 D 60.17
Sigüientes recambios:
Cantidad Número de pedido
2 500 526 00
8 500 812 00
Por correo expreso a...

El pedido de récambios favor dirigirlo a:

- Al servicio HATZ más cercano, dirección verla en página 1, o en el indice separado de direcciones de servicio.

- Alternativa a:

Motorenfabrik HATZ GmbH & Co. KG
D - 94099 Ruhstorf
Alemania
Tel. 08531 / 319-0
Telex 57260
Telefax 08531 / 319 418

Dati da indicare al momento dell'ordine di ricambi:

Per permetterci di consegnare correttamente e con rapidità i vostri ricambi, abbiamo bisogno dei seguenti dati:

1. **Tipo motore, matricola e regime** di rotazione del motore del quale effettuate l'ordine: vedi dati pagina 1.
2. **Numero del catalogo ricambi** dal quale avete effettuato l'ordine: vedi pagina 1.
- 3 **Quantità e codice** del particolare desiderato.
4. **Modo di spedizione** desiderato:
es. per posta, via aerea, corriere.
5. **Indirizzo** esatto del **destinatario** e se necessario, il nome della stazione o aeroporto.

Esempio:

Per tipo di motore: 1 D 60 - 151a
Matricola: 891793002597
Regime: 3000/60
Catalogo ricambi: 1 D 60.17

I seguenti particolari:

Q.tà	Codice
2	500 526 00
8	500 812 00

con pacco postale espresso a...

Gli ordini di parti di ricambio devono essere inviati a:

– il vostro concessionario HATZ più vicino, vedi indirizzo pagina 1, oppure il libretto service HATZ.

– oppure

Motorenfabrik HATZ GmbH & Co. KG
D - 94099 Ruhstorf
Germania
Tel. 08531 / 319-0
Telex 57260
Telefax 08531 / 319 418

	Inhaltsverzeichnis	Index	
M ..	Grundmotor	Basic engine	
00	Ersatzteilsätze	Spare part kits	01
34	Zubehör	Accessories	02
01	Kurbelgehäuse	Crankcase	03+04
02, 03	Kurbelwelle,	Crankshaft	05
04	Nockenw., Massenausgleich	Camshaft, Compensation of masses	06
05, 06	Kolben, Pleuelstange, Zylinder	Piston, conrod, cylinder	07
07	Zylinderkopf	Cylinder head	08
09, 17	Stoßstange, Schwungrad	Pushrod, flywheel	09
10,	Ölpumpe, Regler	Oil pump, governor	10
11	Steuerdeckel	Timing cover	11
12, 14	Startfüllung, Einspritzausrüstung	Extra fuel device, Injection equipment	12
26	Luffführung S, Z, T, U	Air ducting S, Z, T, U	13
26	Luffführung A1D35 - 40	Air ducting A1D35 - 40	14
26	Luffführung C	Air ducting C	15
30 – 32	Drehzahlverstellung, Entlüftung Aufzugvorr.	Speed control, breather, lifting bracket	16
35	Kapsel C	Capsule C	17+18
A ..	Zusatzausrüstung	Equipments	
01	Kraftstoffbehälter	Fuel tank	19
01	Kraftstoffbehälter A1D35 - 40	Fuel tank A1D35 - 40	20
01	Förderpumpe	Fuel feed pump	21
02	Luftfilter	Air filter	22
02	Luftfilter A1D35 - 40	Air filter A1D35 - 40	23
03	Abgasdämpfer S, Z, T, U	Exhaust silencer S, Z, T, U	24
03	Abgasdämpfer C	Exhaust silencer C	25
04	Andrehkurbel,	Starting handle	26
04	Reversierstarter	Recoil starter	27
05	Starter, Generator, Armaturenkasten	Starter, alternator, Instrument box	28 29
06	Motorfüße	Engine brackets	30
09, 11	Abstellvorr., Hubmagnet	Stop device, lifting magnet	31
15	Anschlußgehäuse	Intermediate housing	32
16	Wellenstummel, elast. Kupplung	Stubshaft, Flexible coupling	33
17	Kupplung dauerausrückbar	Clutch perm. disconn.	34
18	Anbauteile Hydraulikpumpe	Mount. parts hydr. pump	35

	Sommaire:	Indice	
M ..	Moteur de base	Motor de base	
00	Jeux de pièces de rechange	Juegos de piezas de recambios	01
34	Accessoires	Accesorios	02
01	Carter moteur	Caja cigueñal	03+04
02, 03	Vilebrequin	Cigüeñal	05
04	Arbre à cames	Arbol de levas	
	Equilibrage des masses	Compensación de las masas	06
05, 06	Piston, bielle, cylindre	Émbolo, biela, cilindro	07
07	Culasse	Culata	08
09, 17	Tige de culbuteur, volant	Varilla de balancín, volante	09
10	Pompe à huile, regulateur	Bomba de aceite, regulador	10
11	Couvercle distribution	Tapa de mando	11
12, 14	Surcharge, Equipment d'injection	Sobre aliment.-arranque, Equipo de inyección	12
26	Carter ventilation S, Z, T, U	Conducción de aire S, Z, T, U	13
26	Carter ventilation A1D35 - 40	Conducción de aire A1D35 - 40	14
26	Carter ventilation C	Conducción de aire C	15
30 - 32	Réglage régime, purge d'air, etrier	Ajuste de revoluciones, purgo de aire, estribo	16
35	Capsule C	Càpsula C	17+18
A ..	Accessoires	Equipos	
01	Reservoir à carburant	Dépósito combustible	19
01	Reservoir à carburant A1D35-40	Dépósito combustible A1D35 - 40	20
01	Pompe d'alimentation	Bomba de alimentación	21
02	Filtre à air	Filtro de aire	22
02	Filtre à air A1D35 - 40	Filtro de aire A1D35 - 40	23
03	Silencieux S, Z, T, U	Silenciador S, Z, T, U	24
03	Silencieux C	Silenciador C	25
04	Manivelle	Manivela	26
04	Demarreur reversible	Arrancador reversible	27
05	Demarreur, alternateur	Arrancador, alternador	28
	Boitier de bord	Cuadro de mando	29
06	Pieds moteur	Soportes del motor	30
09,11	Dis. d'arrêt, el. aimant	Disp. desconect., elevador magnet.	31
15	Bride raccord	Caja de conexión	32
16	Bout de arbre, accouplement elastic	Eje, acoplamiento elastico	33
17	Embrayage debr. continu.	Embrague permanente	34
18	Pièces mont.-pompe hydr.	Piezas mont. bomba hydr.	35

M .. Motore di base

00	Serie guarnizioni	01
34	Kit accessori	02
01	Basamento motore	03+04
02, 03	Albero a gomito	05
04	Albero a camme,	
	Contrappesi di equilibratura	06
05, 06	Pistone, biella, cilindro	07
07	Testa	08
09, 17	Asta bilancieri, volano	09
10	Pompa olio, regolatore	10
11	Coperchio distribuzione	11
12, 14	Supplemento	
	Equipaggiamento iniezione	12
26	Carter ventilatore S, Z, T, U	13
26	Carter ventilatore A1D35 - 40	14
26	Carter ventilatore C	15
30 - 32	Regolatore di giri, sfiatatóio,	
	Anello di trasporto	16
35	Cofanatura silenziata C	17+18

A .. Accessori

01	Serbatoio combustibile	19
01	Serbatoio combustibile A1D35-40	20
01	Pompa A. C.	21
02	Filtro aria	22
02	Filtro aria A1D35 - 40	23
03	Marmitta S, Z, T, U	24
03	Marmitta C	25
04	Manovella	26
04	Avviamento a strappo	27
05	Motorino avviamento, alternatore	28
	Cruscotto	29
06	Staffe supporto motore	30
09, 11	Leva stop, magneti stop	31
15	Flange accoppiamento	32
16	Contralbero, giunto elastico	33
17	Frizione	34
18	Particolari per montaggio pompa idraulica	35

M 00

Ersatzteilsätze
Spare part kits
Jeux de pièces de rechange
Juegos de piezas de recambios
Serie guarnizioni

Tafel Nr.
Tabl. No.
Tavola N.

01

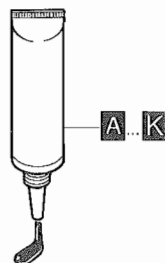
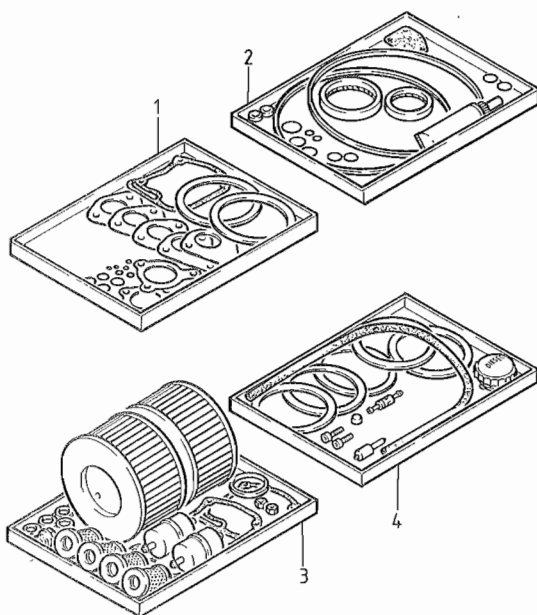

Fig.- No.	HATZ Ident-No.	Stück Qty.				P / W d / D	Bemerkungen Notes
		1D20	1D30	1D60	1D80		
			1D40				
			A1D35				
			A1D40				
<p>W: Im Wartungssatz enthalten. Incl. in maintenance kit. Contenu dans le jeu d'entretien. Incluido en el juego de mantenimiento. Contenuto nella serie manutenzione</p>							<p>P: Im Pannensatz enthalten. Incl. in emergency kit. Contenu dans le jeu secur. Incluido en el juego para averias. Contenuto nella serie di prima necessità.</p>
<p>d: Im Dichtungssatz f. 1 Zyl.-Kopf enthalten. Incl. in gasket set f. 1 cyl. head. Contenu dans le jeu de joint p. 1 culasse. Incluido en el juego de juntas p. 1 culata. Contenuto nella serie guarnizioni p. 1 testa.</p>							<p>D: Im Dichtungssatz Kurbelgeh. Incl. in gasket set crankcase. Contenu dans le jeu de joints carter moteur. Incluido en el juego de juntas caja cigueñal. Contenuto nella serie guarnizioni basamento.</p>
							<p>1: Anzahl pro Satz - Qty. per kit Quantite par jeu Cantidad por juego Quantità per serie</p>
1	01279610	1	-	-	-	P1	Dichtungssatz für 1 Zylinderkopf
1	01279710	-	1	-	-	P1	Gasket set for 1 cyl. head
1	01264210	-	-	1	-	P1	Jeu de joint p. 1 culasse
1	01249210	-	-	-	1	P1	Juego de juntas para 1 culata Serie guarnizioni per 1 testa
2	01279801	1	1	-	-		Dichtungssatz für Kurbelgehäuse
2	01249311	-	-	1	1		Gasket set for crankcase Jeu de joints p. carter moteur Juego de juntas para caja cigueñal Serie guarnizioni basamento
3	01279910	1	1	-	-		Wartungssatz für 1000 h
3	01249410	-	-	1	1		1000 hours maintenance kit
3	01292610	1	1	-	-	*	Kit d'entretien 1000 heures - Juego
3	01292410	-	-	1	1	*	de piezas para servicio 1000 horas Kit di manutenzione a 1000 ore
4	01280000	1	-	-	-		Pannensatz - Emergency kit
4	01280110	-	1	-	-		Kit de secours - Juego para averias
4	01264310	-	-	1	-		Kit di prima necessità
4	01293010	-	-	1	-		1 D 60 C
4	01249510	-	-	-	1		
4	01293110	-	-	-	1		1 D 80 C

* ohne Ölfilter, without oil filter, sans filtre à huile

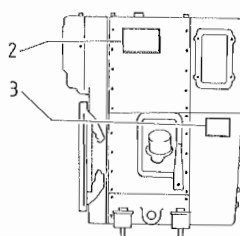
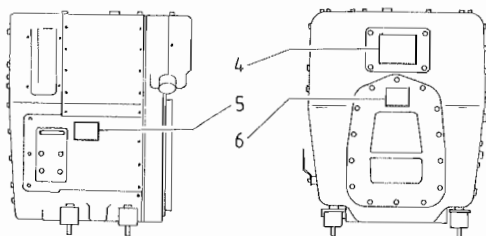
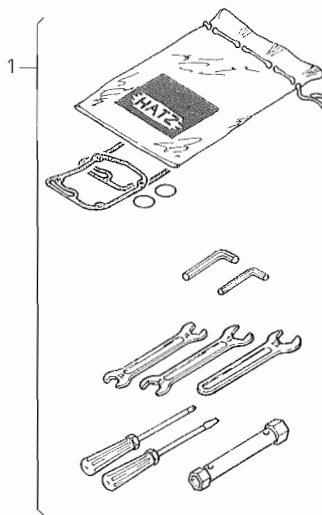
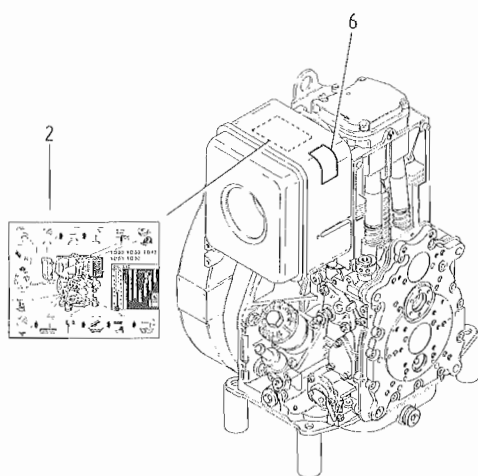

Fig.- No.	HATZ Ident-No.	Stück Qty.				P / W d / D	Bemerkungen Notes
		1D20	1D30	1D60	1D80		
			1D40				
			A1D35				
			A1D40				
1	01247510	1	1	1	1		Zubehörsatz - Accessoires kit Sort. accessoires Juego de accesorios Serie accessorie
2	04048300	1	1	1	1		
3	03614400	-	1	1	1		„C“
4	05034700	-	1	1	1		„C“
5	03614401	-	1	1	1		„C“
6	05025200	-	1	1	1		Handstart, demarr. man.

Dicht- und Klebstoffe

Sealing- and bonding adhesives

Etanchéifiant et Colle

Materias para empaquetar y pegar

Adesivi e collanti

A = 502 230 01	Loctite Activator N	500 ml	} siehe Hinweis auf den einzelnen Bildtafeln as specified in the individual tables suivant les remarques sur les tableau correspondant según las indicaciones de las tablas correspondientes seguire le indicazioni sul quadro corrispondente
B = 502 231 00	Loctite 573	50 ml	
C = 502 232 00	Loctite 601	50 ml	
D = 502 233 00	Loctite 221	50 ml	
E = 502 234 00	Loctite 648	10 ml	
F = 502 238 00	Technicoll 8058	0,75 kg	
+ 502 239 00	Technicoll 8366	0,75 kg	
G = 502 565 01	Loctite IS 407	20 ml	
H = 502 825 01	Silicon	30 ml	
J = 502 830 01	Hochtemp. Paste	500 g	
K = 503 426 00	Hochtemp. Fett	100 g	

M 01

Kurbelgehäuse
Crankcase
Carter moteur
Caja cigueñal
Basamento motore

Tafel Nr.
Tabl. No.
Tavola N.

03

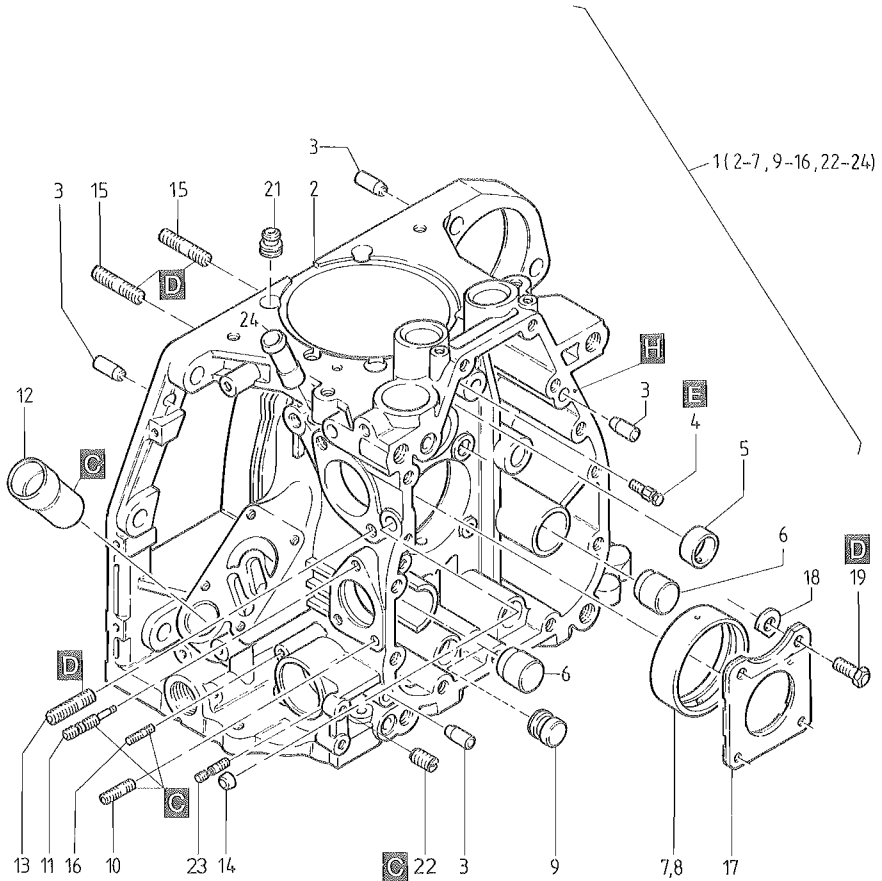

Fig.- No.	HATZ Ident-No.	Stück Qty.				P / W d / D	Bemerkungen Notes
		1D20	1D30	1D60	1D80		
			1D40				
			A1D35				
			A1D40				
1	01270230	1	1	-	-		
1	01249040	-	-	1	1		
2	-----	-	-	-	-		
3	50249101	4	4	4	4		8 M 6 x 20 DIN 6325
4	01269500	1	1	-	-		
4	03793900	-	-	1	1		
5	03793800	1	1	1	1		
6	04022700	1...2	1...2	-	-		Ø 25 mm S, T
6	03794000	-	-	1...2	1...2		Ø 22 mm S, T
7	04022500	1	1	-	-		
7	03793700	-	-	1	1		
8	04048800	1	1	-	-		- 0,5 mm
8	04033700	-	-	1	1		- 0,5 mm
9	04023600	1	1	-	-		} s. Taf., Tabl. 21- } Pos. 4
9	04000800	-	-	1	1		
10	50144300	2	2	2	2		M 6 x 16 DIN 835-A3C
11	03794500	1	1	1	1		
12	03794800	1	1	1	1		
13	50098300	2	2	2	2		M 8 x 20 DIN 835-8.8 A3C
14	50325500	1	1	1	1		10 DIN 443-St A3C
15	50037600	8	8	8	8		M 8 x 20 DIN 835-10.9
16	50328200	2	2	2	2		M 6 x 22 DIN 835-8.8 A3C
17	04011650	1	1	1	1		
18	04069500	0...4	0...4	0...4	0...4		} Axialspiel } End play } Jeux axial } Juego axial
18	04069600	0...4	0...4	0...4	0...4		
19	04062010	4	4	4	4		M 9 x 28
20	-----	-	-	-	-		
21	50384600	-	-	4	4		
22	50357700	1	1	1	1		M 8 x 10 DIN 551 Alu
23	04087400	1	1	1	1		M 6 x 22
24	-----	-	-	-	-		

M 01

Kurbelgehäuse
Crankcase
Carter moteur
Caja cigueñal
Basamento motore

Tafel Nr.
Tabl. No.
Tavola N.

04

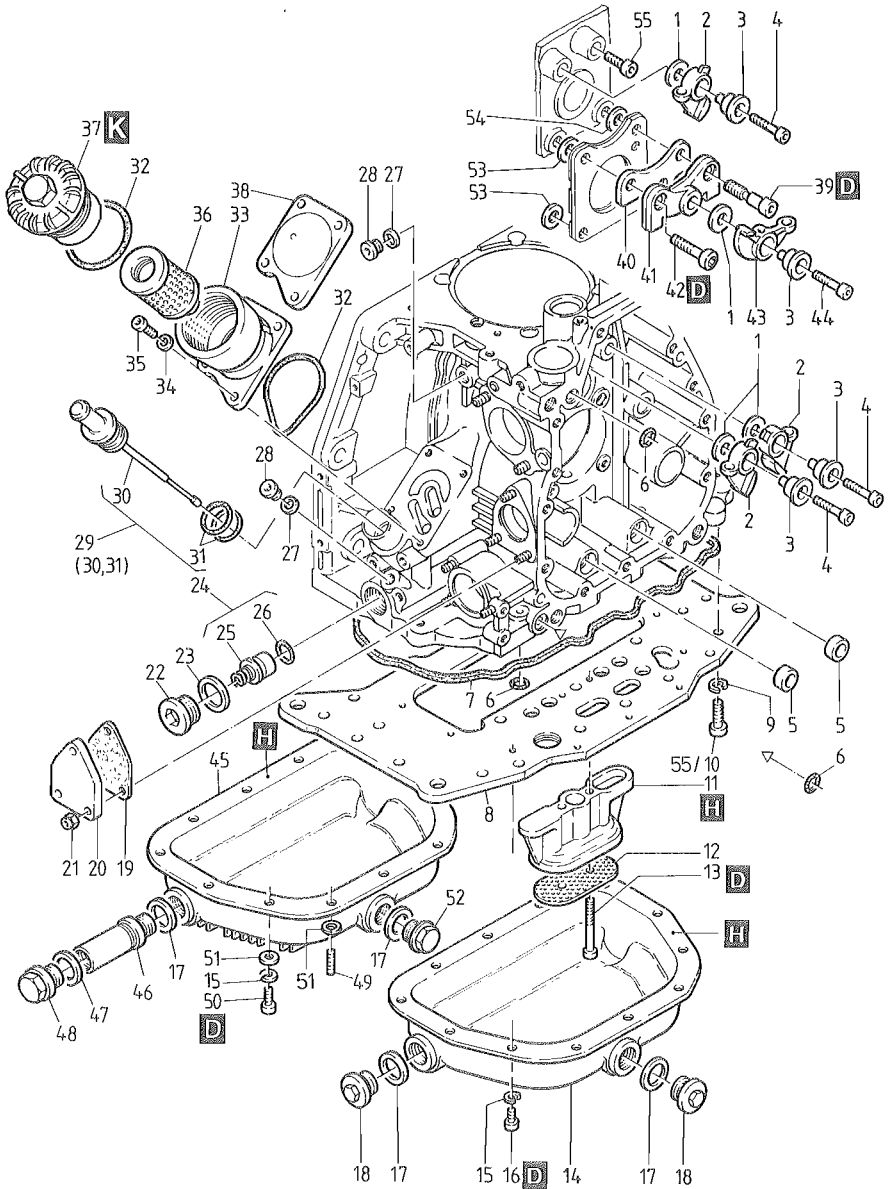

Fig.- No.	HATZ Ident-No.	Stück Qty.				P / W d / D	Bemerkungen Notes
		1D20	1D30	1D60	1D80		
			1D40				
			A1D35				
			A1D40				
1	03794100	2	2	2	2		
2	03794300	2	2	2	2		(T-U=1)
3	03794201	2	2	2	2		
4	50051000	2	2	2	2		M 6 x 30 DIN 912-8.8 (T-U=1)
5	03795800	2	2	2	2	D1	12 x 18,3 x 7,3
6	50329000	3	3	3	3	D3	9,5 x 2,5
7	03795100	1	1	1	1	D1	265 x 269,4 x 3,6
8	01270300	1	1	-	-		
8	01302200	-	1	-	-		1D35
8	01248800	-	-	1	1		
9	50347301	22	22	22	22		VHZ 8 A3C
10	50171500	22	22	22	22		M 8 x 25 DIN 912-8.8 A3C 1D60 - 80 C = 21
11	04023300	1	1	-	-		
11	03794900	-	-	1	1		
12	03795000	1	1	1	1		
13	50051100	2	2	-	-		M 6 x 30 DIN 6912-8.8
13	50327100	-	-	2	2		M 6 x 50 DIN 6912-8.8 A3C
14	01255410	1	1	-	-		
14	01241700	-	-	1	1		S, Z, T, U
15	50170900	12	12	12	12		6 DIN 128 A3C
16	50329100	12	12	12	12		M 6 x 10 DIN 912-8.8
17	50001600	2	2	2	2	D2,W4	A 22 x 27 DIN 7603-Cu
18	50373100	2	2	2	2	W1	AM 22 x 1,5 MAGN.
19	03794600	1	1	1	1	D1	
20	03794700	1	1	1	1		
21	50328300	3	3	3	3		VM6 DIN 980-8 A3C
22	04011100	1	1	1	1		M 24 x 1,5
23	50286400	1	1	1	1	D1	A 24 x 29 DIN 7603-Cu
24	00328802	1	1	1	1		
25	-----	-	-	-	-		
26	50224500	1	1	1	1	D1	13,3 x 2,4
27	50062400	2	2	2	2	D2	A 10 x 13,5 DIN 7603-Cu
28	50062300	2	2	2	2		M 10 x 1 DIN 908-5.8 A3C

M 01

Kurbelgehäuse
Crankcase
Carter moteur
Caja cigueñal
Basamento motore

Tafel Nr.
Tabl. No.
Tavola N.

04

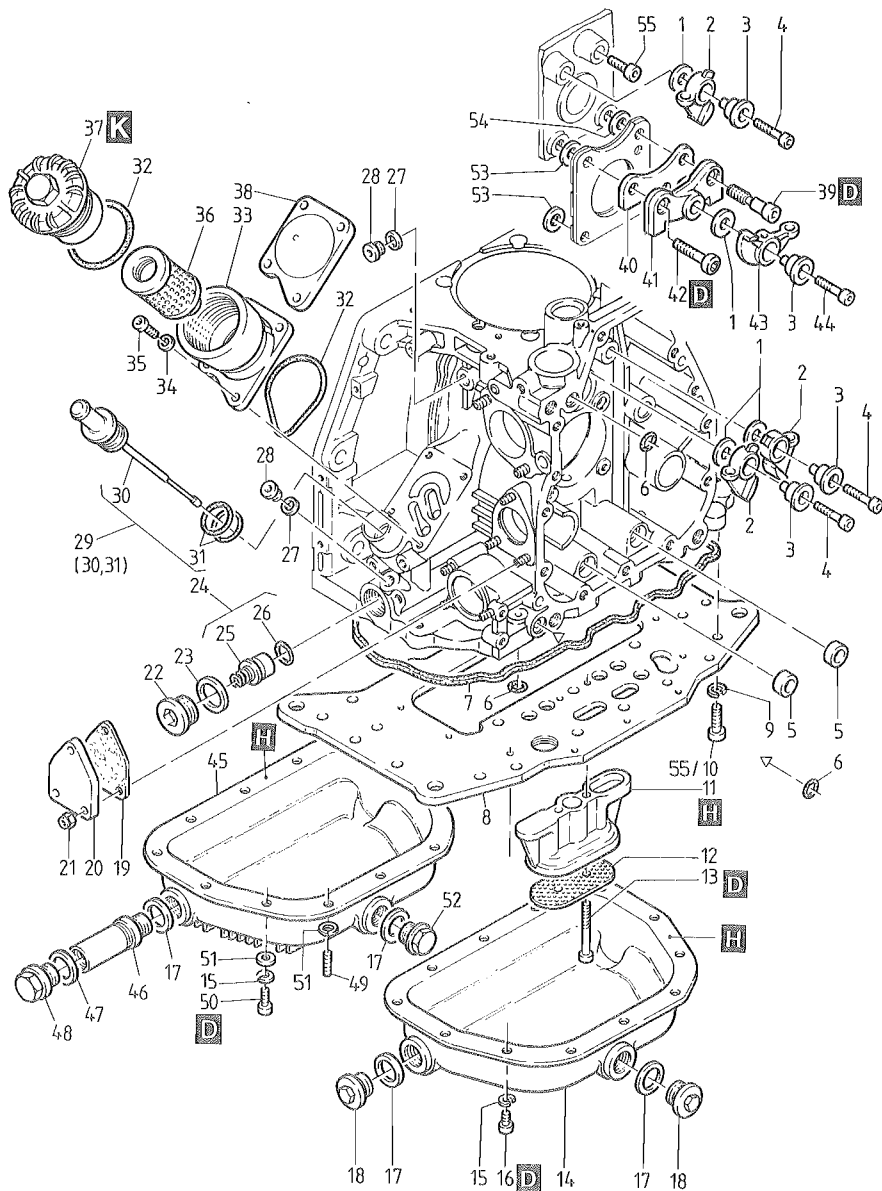

Fig.- No.	HATZ Ident-No.	Stück Qty.				P / W d / D	Bemerkungen Notes
		1D20	1D30	1D60	1D80		
			1D40				
			A1D35				
			A1D40				
29	01255200	1	1	-	-		
29	01241500	-	-	1	1		
30	-----	-	-	-	-		
31	50359700	2	2	2	2	D2	20,29 x 2,62
32	50329200	2	2	2	2	D2,W1	50 x 55 x 3
33	04079800	1	1	1	1		
34	50081200	4	4	4	4		A 6 DIN 137 A3C
35	50170600	4	4	4	4		M 6 x 20 DIN 912-8.8 A3C
36	01480000	1	1	1	1	W4	
37	01248900	1	1	1	1		
38	04033401	1	1	1	1		
39	04053210	1	1	1	1		„T-U“ M 9
40	04036920	1	1	-	-		„T-U“
41	04024220	1	1	1	1		„T-U“
42	04062110	1	1	1	1		M 8 x 36
43	04024301	1	1	1	1		„T-U“
44	50170800	1	1	1	1		„T-U“ M 6 x 25 DIN 912-8.8
45	04045800	-	-	1	1		„C“
46	03550500	-	1	-	-		„C“
46	04046300	-	-	1	1		„C“
47	50001400	1	1	1	1		A 18 x 22 DIN 7603 Cu
48	50044200	1	1	1	1		M 18 x 1,5 DIN 910 „C“
49	50139200	4	4	4	4		M 6 x 16 DIN 939-8.8
50	50050700	8	8	8	8		M 6 x 16 DIN 912-8.8
51	50144500	12	12	12	12		6,4 DIN 125-St A3C
52	50140400	1	1	1	1		AM 22 x 1,5 DIN 7604 A3C „C“
53	04069500	0...3	0...3	0...3	0...3		1,05 mm } Axialspiel 0,1-0,3 mm
53	04069600	0...3	0...3	0...3	0...3		1,20 mm } End play 0,1-0,3 mm
54	04069800	0...1	0...1	0...1	0...1		1,05 mm } Jeu axial 0,1-0,3 mm
54	04069900	0...1	0...1	0...1	0...1		1,20 mm } Juego axial 0,1-0,3 mm
55	04065400	1	1	1	1		„T-U“ M 6 X 12
55	50114400	-	-	1	1		M 8 x 25 DIN 6912-8.8 A3C 1D60 - 80 C

M 02

Kurbelwelle
Crankshaft
Vilebrequin
Cigueñal
Albero a gomito

M 03

Lagerflansch
Bearing flange
Palier
Brida de cojinete
Supporto

Tafel Nr.
Tabl. No.
Tavola N.

05

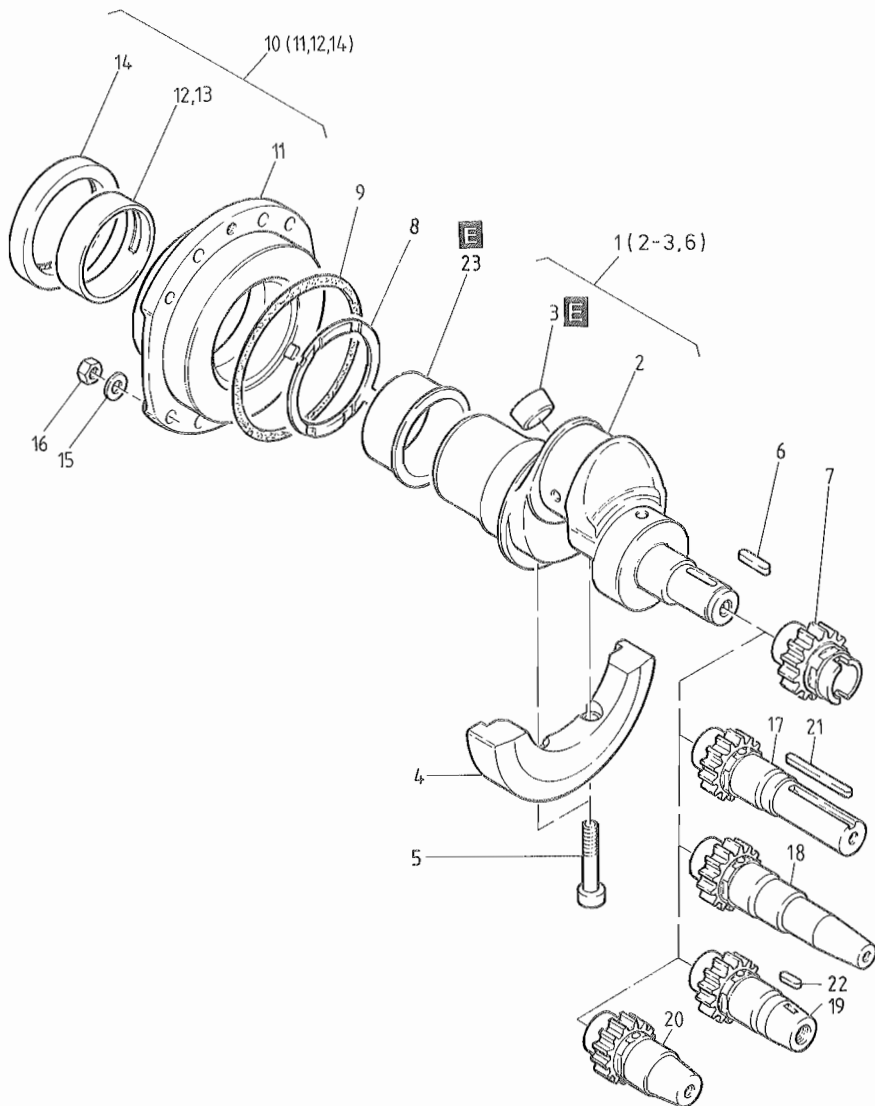

Fig.- No.	HATZ Ident-No.	Stück Qty.	1D20	1D30	1D60	1D80	P / W d / D	Bemerkungen Notes
			1D20	1D30	1D60	1D80		
				1D40				
				A1D35				
				A1D40				
1	01269900	1	1	-	-			
1	01269810	-	-	1	1			
2	-----	-	-	-	-			
3	50345800	1	1	-	-		22	DIN 443
3	50087200	-	-	1	1		28	DIN 443
4	04023501	1	1	-	-			
4	03796000	-	-	1	1			
5	50127900	2	2	-	-		M 8 x 40	DIN 912-10.9
5	50055000	-	-	2	2		M 10 x 50	DIN 912-10.9
6	50362600	1	1	1	1		A 6 x 4 x 32	DIN 6885 St 60
7	03796110	1	1	1	1			
8	04024600	1	1	-	-			
8	04000600	-	-	1	1			
9	50349700	1	1	-	-	D1	100 x 2,5	
9	50224900	-	-	1	1	D1	123 x 2,5	
10	01292000	1	1	-	-			
10	01292100	-	-	1	1			
11	-----	-	-	-	-			
12	04024500	1	1	-	-			
12	04006800	-	-	1	1			
13	04048700	1	1	-	-		- 0,5 mm	
13	04036100	-	-	1	1		- 0,5 mm	
14	50368101	1	1	-	-	D1	52 x 80 x 10	
14	50362700	-	-	1	1	D1	62 x 90 x 10	
15	50413600	8	8	8	8		8,4	DIN 125-St A3C
16	50364300	8	8	8	8		M 8	DIN 934-10 A3C
17	04023110	1	1	1	1		SAE ...2 Ø 1" zyl., cyl.	
18	01485500	1	1	1	1		SAE ...4 Ø 1"	} keg. } tap. } con.
19	04022910	1	1	1	1		ITAL. ...3 Ø 30 mm	
20	05033200	1	1	1	1		ITAL. ...6 Ø 23 mm	
21	03962700	1	1	1	1		A 6,35 x 63	
22	50017800	1	1	1	1		4 x 6,5	DIN 6888
23	50414400	-	-	0...1	0...1			

M 04 Nockenwelle, Massenausgleich
 Camshaft, compensation of masses
 Arbre à cames, équilibrage
 Arbol de levas, compensación de las masas
 Albero a camme, masse equilibratura

Tafel Nr.
 Tabl. No.
 Tavola N.

06

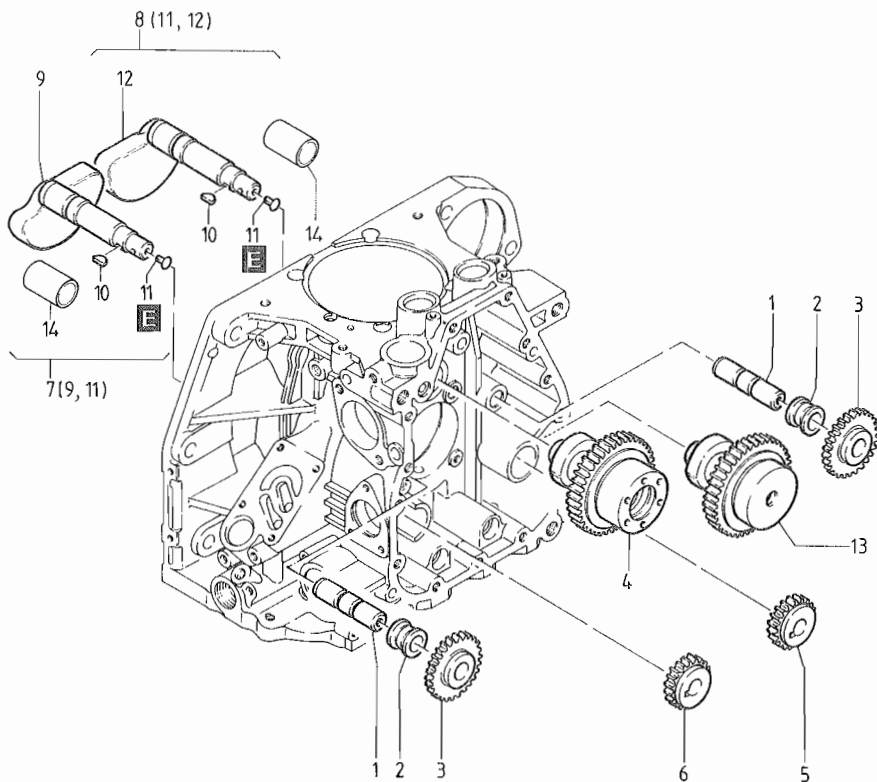

Fig.- No.	HATZ Ident-No.	Stück Qty.				P / W d / D	Bemerkungen Notes
		1D20	1D30	1D60	1D80		
			1D40				
			A1D35				
			A1D40				
1	03796400	2	2	2	2		Z,U,C
2	03796500	2	2	2	2		Z,U,C
3	01242000	2	2	2	2		Z,U,C
4	04024010	1	1	-	-		S,Z,C
4	03797020	-	-	1	1		S,Z,C
5	03796800	1	1	1	1		Z,U,C
6	03796900	1	1	1	1		Z,U,C
7	01270000	1	1	-	-		Z,U,C
7	01267300	-	-	1	1		Z,U,C
8	01270100	1	1	-	-		Z,U,C
8	01267200	-	-	1	1		Z,U,C
9	-----	-	-	-	-		Z,U,C
10	50324900	2	2	2	2		Z,U,C 3 x 3,7 DIN 6888 St 60
11	-----	-	-	-	-		Z,U,C
12	-----	-	-	-	-		Z,U,C
13	04037000	1	1	-	-		T,U
13	04022200	-	-	1	1		T,U
14	04023900	2	2	-	-		

M 05

Kolben, Pleuel
Piston, conrod
Piston, bielle
Embolo, biela
Pistone, biella

M 06

Zylinder
Cylinder
Cylindre
Cilindro
Cilindro

Tafel Nr.
Tabl. No.
Tavola N.

07

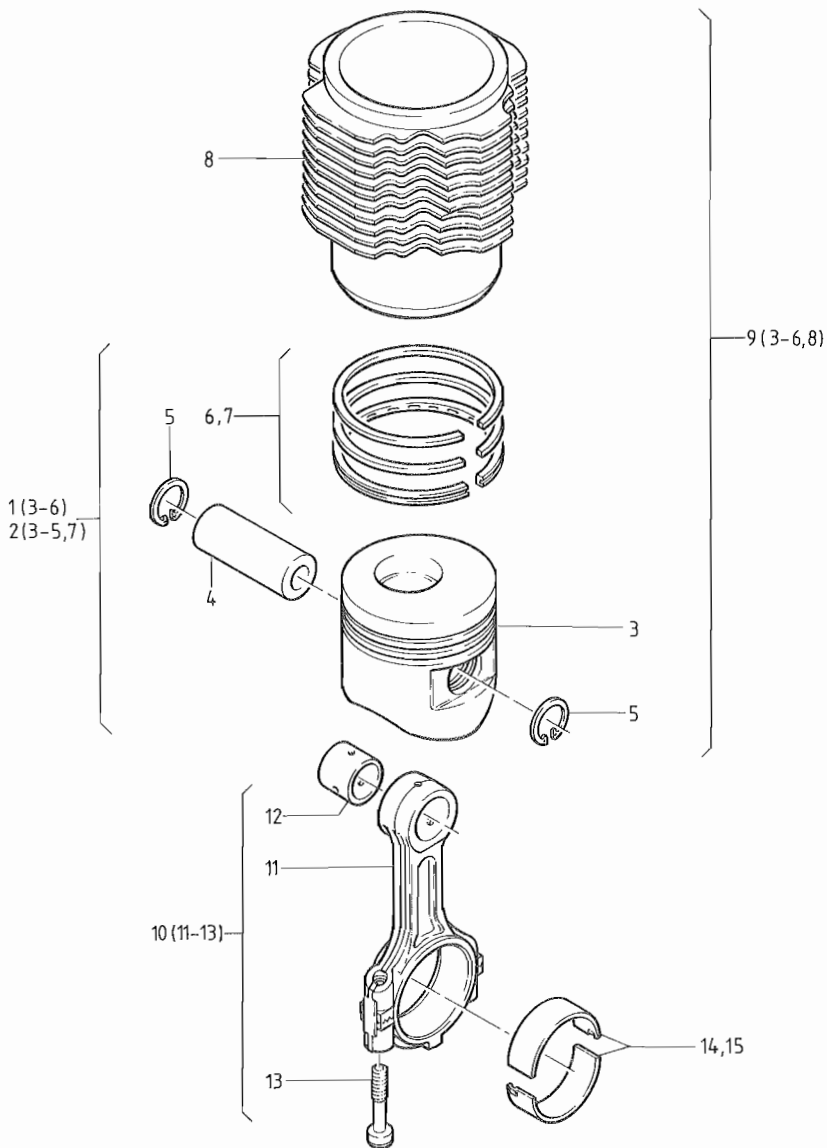

Fig.- No.	HATZ Ident-No.	Stück Qty.				P / W d / D	Bemerkungen Notes
		1D20	1D30	1D60	1D80		
			1D40				
			A1D35				
			A1D40				
1	-----	1	-	-	-		
1	01258503	-	1	-	-		
1	01308201	-	1	-	-		1D30, 1D40 ε = 22
1	01273701	-	-	1	-		
1	01243901	-	-	-	1		
2	-----	1	-	-	-		+ 0,5 mm
2	-----	1	-	-	-		+ 1,0 mm
2	01264903	-	1	-	-		+ 0,5 mm
2	01269403	-	1	-	-		+ 1,0 mm
2	01273901	-	-	1	-		+ 0,5 mm
2	01274101	-	-	1	-		+ 1,0 mm
2	01265101	-	-	-	1		+ 0,5 mm
2	01265201	-	-	-	1		+ 1,0 mm
3	-----	-	-	-	-		
4	-----	1	-	-	-		
4	50363200	-	1	-	-		25 x 13 x 62
4	50382400	-	-	1	-		30 x 17 x 62
4	50353600	-	-	-	1		30 x 17 x 75
5	-----	2	-	-	-		
5	50381200	-	2	-	-		A 25 DIN 73130
5	50020800	-	-	2	2		J 30 x 1,2 DIN 472
6	-----	1	-	-	-		
6	01258603	-	1	-	-		
6	01223700	-	-	1	-		
6	01247300	-	-	-	1		
7	-----	1	-	-	-		+ 0,5 mm
7	-----	1	-	-	-		+ 1,0 mm
7	01267803	-	1	-	-		+ 0,5 mm
7	01273603	-	1	-	-		+ 1,0 mm
7	01235600	-	-	1	-		+ 0,5 mm
7	01227200	-	-	1	-		+ 1,0 mm
7	01264500	-	-	-	1		+ 0,5 mm
7	01265000	-	-	-	1		+ 1,0 mm

M 05

Kolben, Pleuel
Piston, conrod
Piston, bielle
Embolo, biela
Pistone, biella

M 06

Zylinder
Cylinder
Cylindre
Cilindro
Cilindro

Tafel Nr.
Tabl. No.
Tavola N.

07

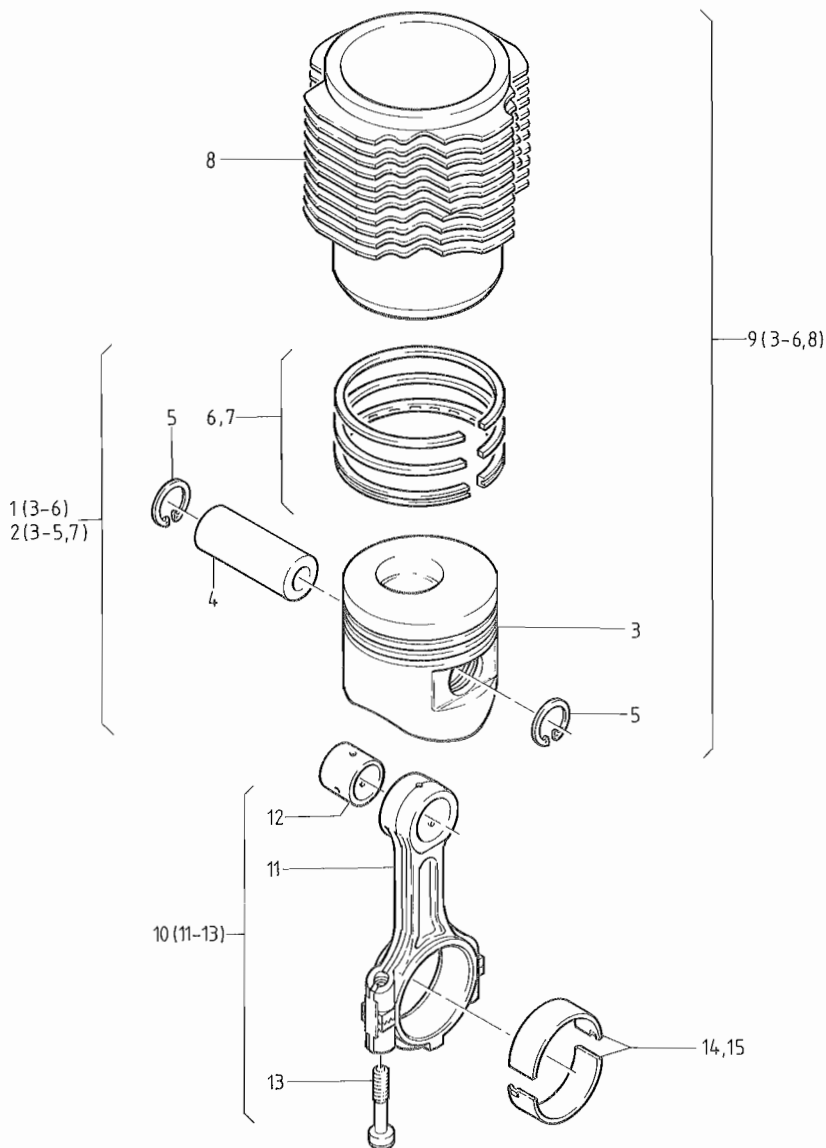

Fig.- No.	HATZ Ident-No.	Stück Qty.				P / W d / D	Bemerkungen Notes
--------------	-------------------	---------------	--	--	--	----------------	----------------------

1D20	1D30	1D60	1D80
	1D40		
	A1D35		
	A1D40		

8	-----	-	-	-	-	
9	01280300	1	-	-	-	
9	01280401	-	1	-	-	
9	01264600	-	-	1	-	
9	01249100	-	-	-	1	
10	01258300	1	1	-	-	
10	01244000	-	-	1	1	
11	-----	-	-	-	-	
12	04065600	1	1	-	-	
12	04032200	-	-	1	1	
13	03781100	2	2	-	-	
13	04001800	-	-	2	2	
14	04026500	1	1	-	-	
14	04001900	-	-	1	1	
15	04065700	1	1	-	-	- 0,5 mm
15	04033100	-	-	1	1	- 0,5 mm

Fig.- No.	HATZ Ident-No.	Stück Qty.				P / W d / D	Bemerkungen Notes
		1D20	1D30	1D60	1D80		
			1D40				
			A1D35				
			A1D40				
1	01272510	1	-	-	-		
1	01272410	-	1	-	-		
1	01264710	-	-	1	-		
1	01264810	-	-	-	1		
2	-----	-	-	-	-		
3	04028710	2	2	-	-		
3	04008710	-	-	2	2		
4	50279200	1	1	-	-	M 8 x 40	DIN 835-8.8 A3C
4	50038400	-	-	1	1	M 8 x 35	DIN 835-8.8 A3C
5	01290910	1	1	-	-		
5	01468910	-	-	1	1		
6	04034300	1	-	-	-		
6	04028900	-	1	-	-		
6	04024901	-	-	1	-		
6	04005001	-	-	-	1		
7	04034400	1	-	-	-		
7	04029000	-	1	-	-		
7	04025001	-	-	1	-		
7	04005101	-	-	-	1		
8	04029110	2	2	-	-		
8	04005200	-	-	2	2		
9	04029300	2	2	-	-		
9	04005300	-	-	2	2		
10	04029200	2	2	-	-		
10	04005400	-	-	2	2		
11	03171910	2	2	-	-		
11	03786300	-	-	2	2		
12	04003710	1	1	1	1		
13	-----	-	-	-	-		
14	04070700	1	1	1	1		
15	03778401	1	1	1	1		
16	-----	-	-	-	-		
17	50117200	1	1	1	1		
18	03365710	1	1	1	1		
19	03366001	1	1	1	1		

M 07

Zylinderkopf
Cylinder head
Culasse
Culata
Testa

Tafel Nr.
Tabl. No.
Tavola N.

08

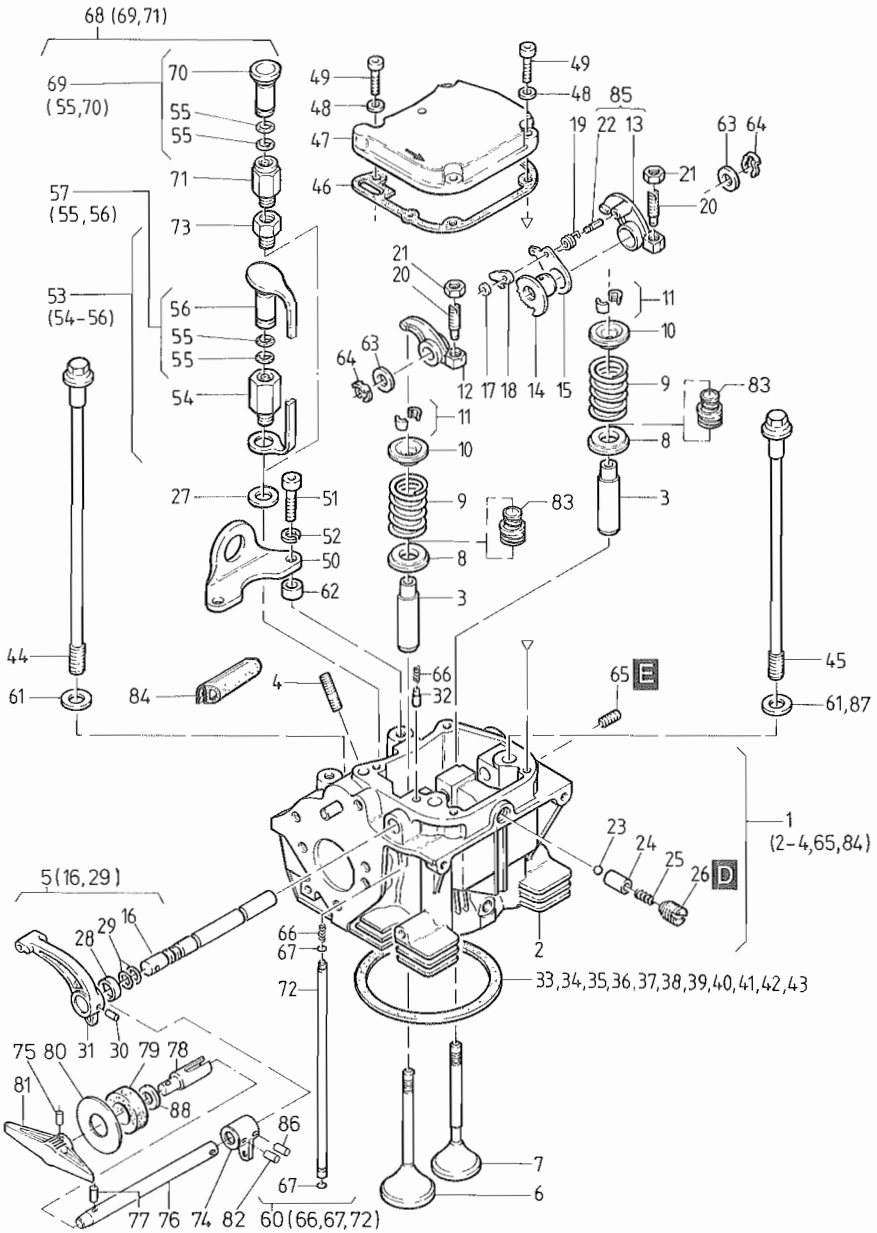

Fig.- No.	HATZ Ident-No.	Stück Qty.				P / W d / D	Bemerkungen Notes
		1D20	1D30	1D60	1D80		
			1D40				
			A1D35				
			A1D40				
20	03783000	2	2	2	2		
21	03173100	2	2	2	2	W2	
22	-----	-	-	-	-		
23	50123800	1	1	1	1		7 mm III DIN 5401
24	04004700	1	1	1	1		
25	04004800	1	1	1	1		
26	01245200	1	1	1	1		
27	50001100	1	1	1	1	d1	A 12 x 15,5 DIN 7603-Cu
28	04048900	-	-	1	1	d1	
29	40022300	2	2	2	2	d2	8 x 2
30	50248600	1	1	1	1		4 x 20 DIN 7343
31	04009810	1	1	1	1		
31	04059700	-	1	-	-		1D35
32	04004100	-	-	1	1		
33	04056700	-	0...1	-	-		0,3 mm
34	04056800	-	0...1	-	-		0,4 mm
35	04034800	0...1	-	-	-		0,5 mm
35	04027300	-	0...1	-	-		0,5 mm
35	04057600	-	-	0...1	-		0,5 mm
35	04068800	-	-	-	0...1		0,5 mm
36	04034900	0...1	-	-	-		0,6 mm
36	04027400	-	0...1	-	-		0,6 mm
36	04053400	-	-	0...1	-		0,6 mm
36	04036800	-	-	-	0...1		0,6 mm
37	04035000	0...1	-	-	-		0,7 mm
37	04027500	-	0...1	-	-		0,7 mm
37	04036300	-	-	0...1	-		0,7 mm
37	04036500	-	-	-	0...1	d1	0,7 mm
38	04035100	0...1	-	-	-		0,8 mm
38	04027600	-	0...1	-	-		0,8 mm
38	04036400	-	-	0...1	-		0,8 mm
38	04036600	-	-	-	0...1	d1	0,8 mm
39	04035200	0...1	-	-	-		0,9 mm
39	04027700	-	0...1	-	-		0,9 mm
39	04025100	-	-	0...1	-		0,9 mm
39	04002700	-	-	-	0...1	d1	0,9 mm

M 07

Zylinderkopf
Cylinder head
Culasse
Culata
Testa

Tafel Nr.
Tabl. No.
Tavola N.

08

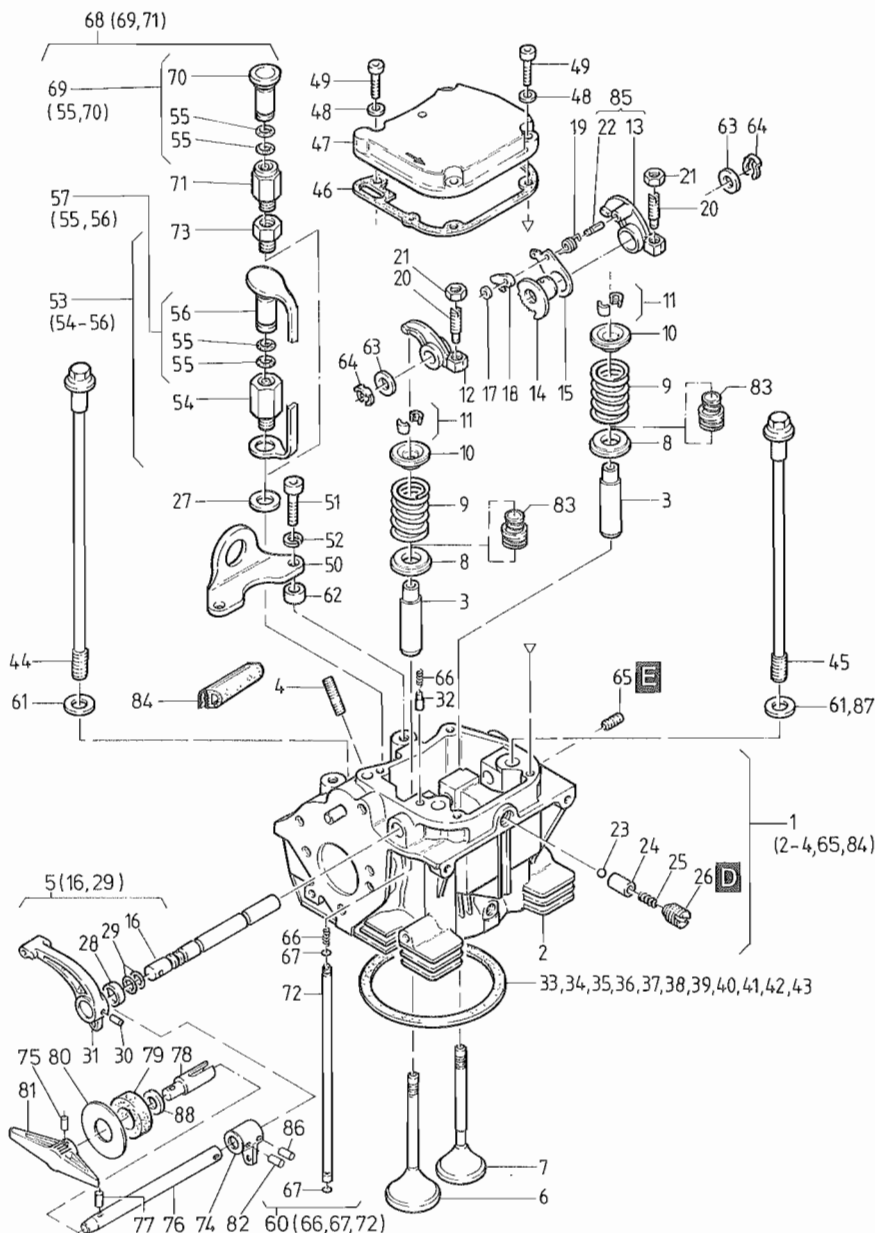

Fig.- No.	HATZ Ident-No.	Stück Qty.				P / W d / D	Bemerkungen Notes
		1D20	1D30	1D60	1D80		
			1D40				
			A1D35				
			A1D40				
40	04035300	0...1	-	-	-	d1	1,0 mm
40	04027800	-	0...1	-	-	d1	1,0 mm
40	04025200	-	-	0...1	-		1,0 mm
40	04002800	-	-	-	0...1		1,0 mm
41	04035400	0...1	-	-	-		1,1 mm
41	04027900	-	0...1	-	-		1,1 mm
41	04025300	-	-	0...1	-		1,1 mm
41	04002900	-	-	-	0...1		1,1 mm
42	04035500	0...1	-	-	-	d1	1,2 mm
42	04028000	-	0...1	-	-	d1	1,2 mm
42	04025400	-	-	0...1	-		1,2 mm
42	04003000	-	-	-	0...1		1,2 mm
43	04035600	0...1	-	-	-		1,3 mm
43	04028100	-	0...1	-	-		1,3 mm
43	04025500	-	-	0...1	-		1,3 mm
43	04003100	-	-	-	0...1		1,3 mm
44	04028600	2	2	-	-		251,5 mm
44	04003200	-	-	2	2		305 mm
45	04028500	2	2	-	-		174 mm
45	04003300	-	-	2	2		258 mm
46	04006111	1	1	1	1	d1,W3	
47	01245410	1	1	1	1		
48	50081200	4	4	4	4	P4	A 6 DIN 137 A3C
49	50170800	4	4	4	4	P2	M 6 x 25 DIN 912-8.8
50	04008100	1	1	1	1		
51	50175900	2	2	-	-		M 8 x 30 DIN 912-8.8 A3C
51	50366300	-	-	2	2		M 8 x 20 DIN 912-8.8 A3C
52	50208500	2	2	2	2		8 DIN 128 A3C
53	01493200	1	1	1	1		S, Z, T, U
54	-----	-	-	-	-		
55	40081700	2	2	2	2	d2	12 x 2
56	-----	-	-	-	-		
57	01308300	1	1	1	1	P1	S, Z, T, U

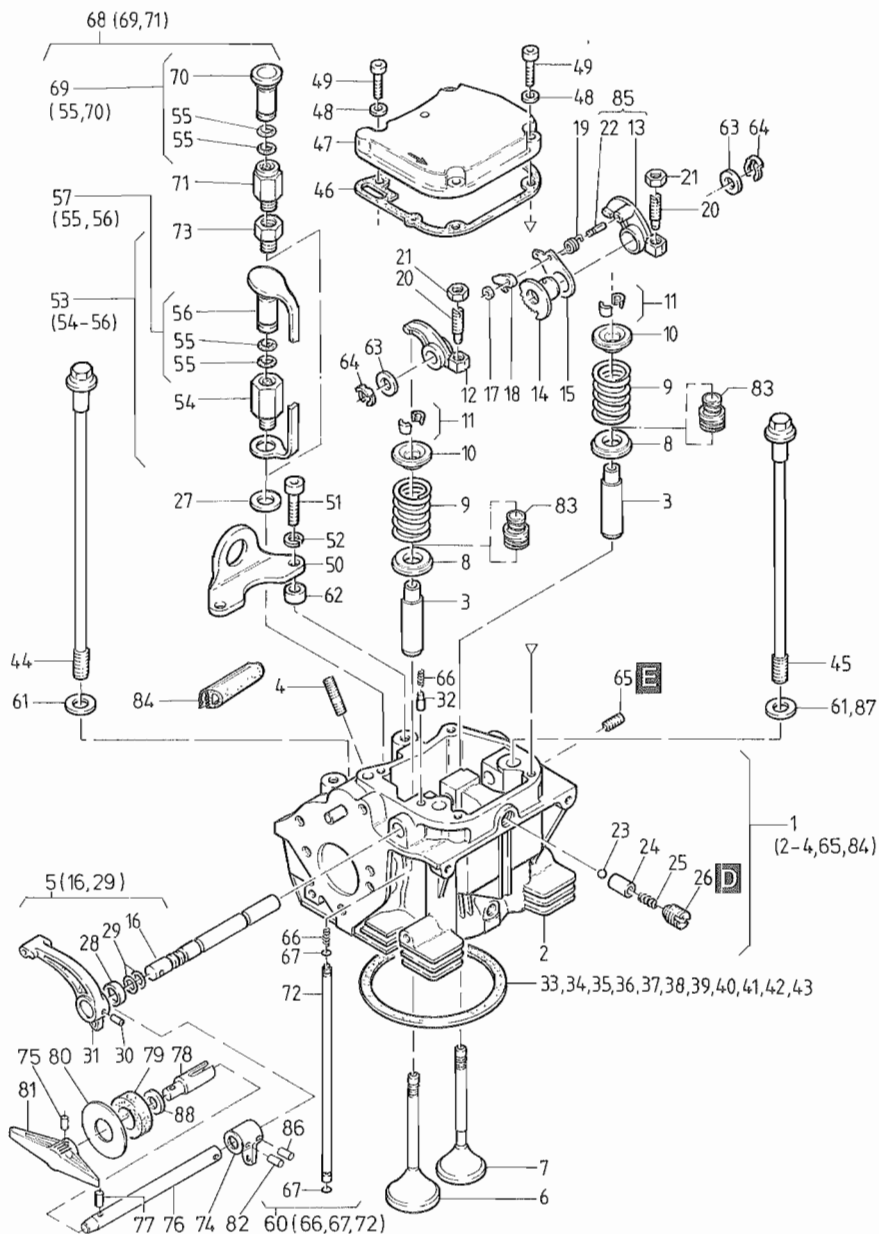

Fig.- No.	HATZ Ident-No.	Stück Qty.				P / W d / D	Bemerkungen Notes
		1D20	1D30	1D60	1D80		
			1D40				
			A1D35				
			A1D40				
58	-----	-	-	-	-		
59	-----	-	-	-	-		
60	01269601	1	1	-	-		
60	01269700	-	-	1	1		
61	03794100	4	4	-	-		10,1 x 22 x 3
61	03457500	-	-	2	2		12,5 x 24 x 2,5
62	04008000	1	1	-	-		
63	03457500	2	2	-	-		12,5 x 24 x 2,5
64	50353300	2	2	-	-		
65	50366800	1	1	-	-		M 6 x 12 DIN 835-8.8 A3C
66	04004200	1	1	2	2		
67	50330100	2	2	2	2	d2	4 x 1,2
68	01280600	1	1	1	1		„C“
69	01275610	1	1	1	1	P1	„C“, A1D35 - A1D40
70	-----	-	-	-	-		
71	-----	-	-	-	-		
72	-----	-	-	-	-		
73	04060500	-	1	-	-		1D35
74	04047910	1	1	1	1		„C“
75	50132000	1	1	1	1		4 x 16 DIN 1481
76	04083310	1	1	-	-		„C“
76	04048210	-	-	1	1		„C“
77	50034500	1	1	1	1		4 x 14 DIN 1481
78	04048110	1	1	1	1		„C“
79	03579800	2	2	1	1		„C“
80	04048000	1	1	1	1		„C“
81	03778200	1	1	1	1		„C“
82	50132000	1	1	1	1		4 x 16 DIN 1481
83	50405700	2	2	-	-		
83	50405200	-	-	2	2		
84	04070400	-	1	-	-		1D30, 1D40 60 mm
85	01285010	1	1	1	1		
86	50034600	1	1	1	1		4 x 18 DIN 1481
87	03915100	-	-	2	2		12,5 x 24 x 0,5
88	03787300	1	1	1	1		10,5 x 21 x 0,2

M 09 Stoßstangen
 Pushrod
 Tige de culbuteur
 Varilla de balancín
 Asta bilanciare

M 17 Schwungrad
 Flywheel
 Volant
 Volante
 Volano

Tafel Nr.
 Tabl. No.
 Tavola N.
09

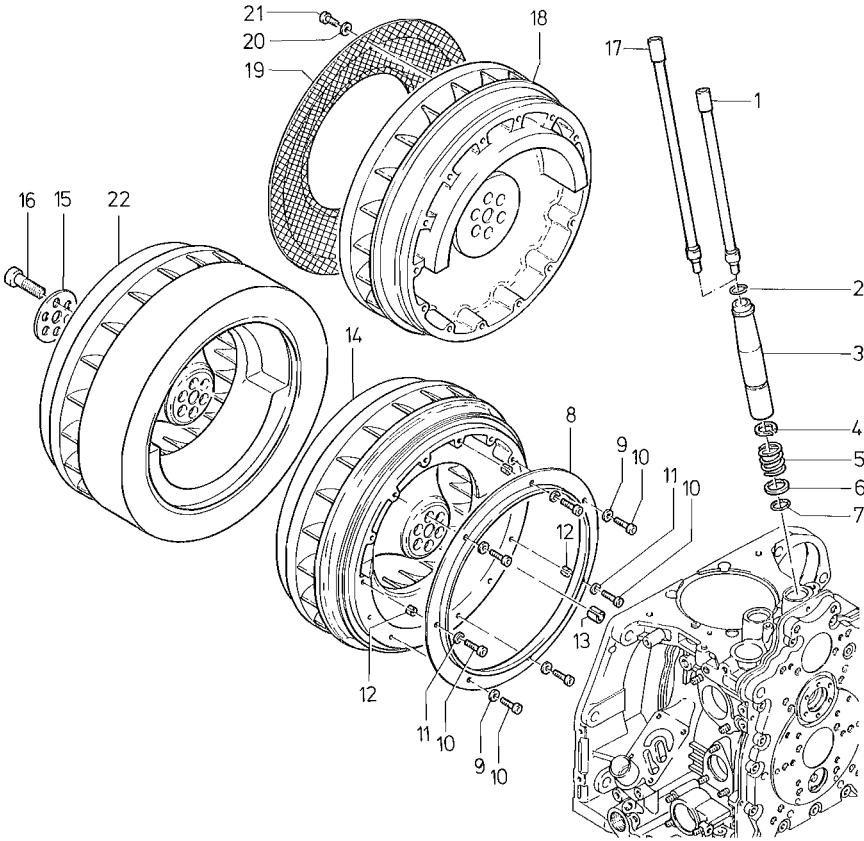

Fig.- No.	HATZ Ident-No.	Stück Qty.				P / W d / D	Bemerkungen Notes
		1D20	1D30	1D60	1D80		
			1D40				
			A1D35				
			A1D40				
1	01259310	2	2	-	-		„T-U“ = 1
1	01244310	-	-	2	2		„T-U“ = 1
2	50330200	2	2	2	2	d2	19 x 3
3	04027200	2	2	-	-		
3	04002500	-	-	2	2		
4	50347000	2	2	2	2		AS 24 x 1,75 DIN 471
5	04002600	2	2	2	2		
6	04002000	2	2	2	2		
7	50411300	2	2	-	-	d2	23 x 3 grün, green
7	50330300	-	-	2	2		23 x 3
8	04030600	1	1	-	-		
8	04007500	-	-	1	1		
9	50147200	3	3	-	-		4,3 DIN 125-St -A3C
10	50327300	6	6	-	-		M 4 x 20 DIN 912-8.8 A3C
10	50397100	-	-	7	7		M 4 x 10 DIN 912-8.8 A3C
11	50002600	3	3	-	-		5 DIN 128
12	50327400	3	3	-	-		5 x 10 DIN 7346
13	04033000	1	1	-	-		
13	03123700	-	-	1	1		
14	04034710	1	-	-	-		
14	04026110	-	1	-	-		
14	04025720	-	-	1	-		
14	04007130	-	-	-	1		
15	04026600	1	1	-	-		
15	04007410	-	-	1	1		
16	50132800	6	6	-	-		M 10 x 40 DIN 912-10.9
16	50363100	-	-	6	6		M 12 x 1,5 x 40 DIN 912-10.9
17	01263610	1	1	-	-		„T-U“
17	01257710	-	-	1	1		„T-U“
18	04038110	1	-	-	-		„T-U“
18	04037210	-	1	-	-		„T-U“
18	04038020	-	-	1	-		„T-U“
18	04024120	-	-	-	1		„T-U“
19	01301200	1	1	-	-		
19	01301300	-	-	1	1		
20	50144500	-	-	6	6		6,4 DIN 125-St A3C
21	50025400	-	-	6	6		M 6 x 10 DIN 933-8.8 A3C
22	04079900	-	1	-	-		} Schwungrad schwer Flywheel heavy, Volant lourd Volante pesado
22	04007130	-	-	1	-		
22	04074500	-	-	-	1		

M 10

Ölpumpe, Regler
Oil pump, governor
Pompe à huile, regulateur
Bomba de aceite, regulador
Pompa olio, regolatore

Tafel Nr.
Tabl. No.
Tavola N.

10

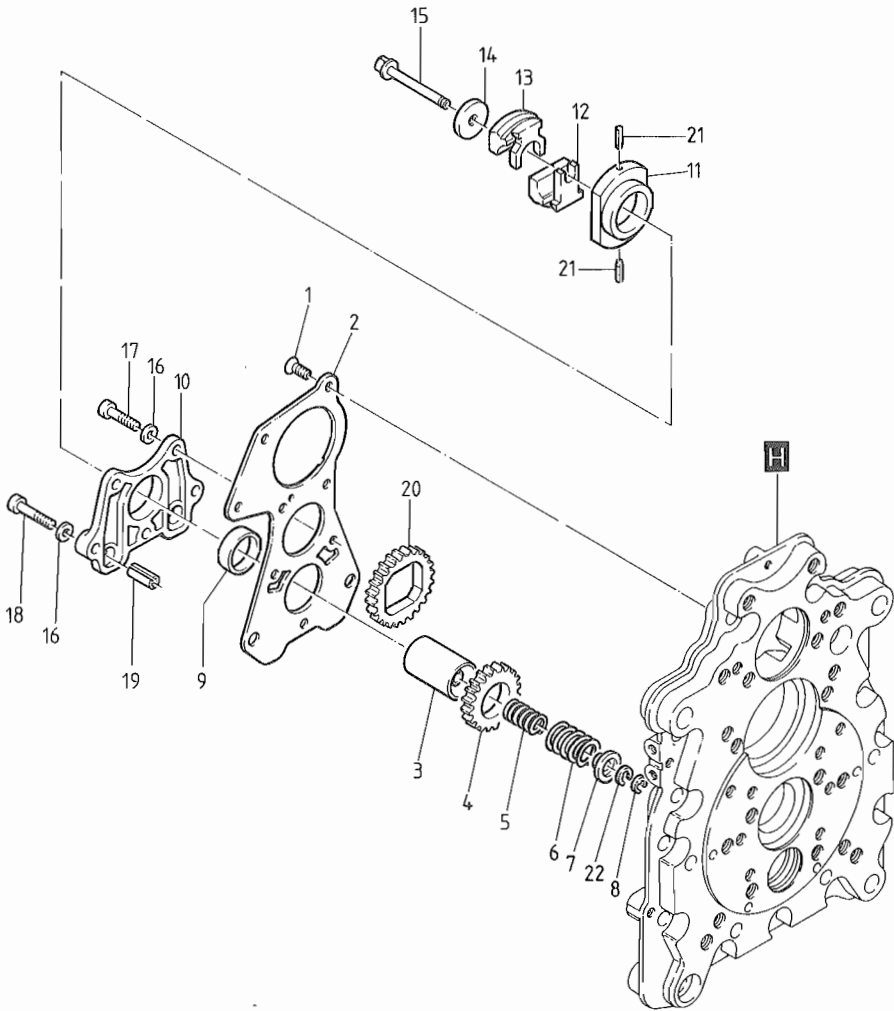
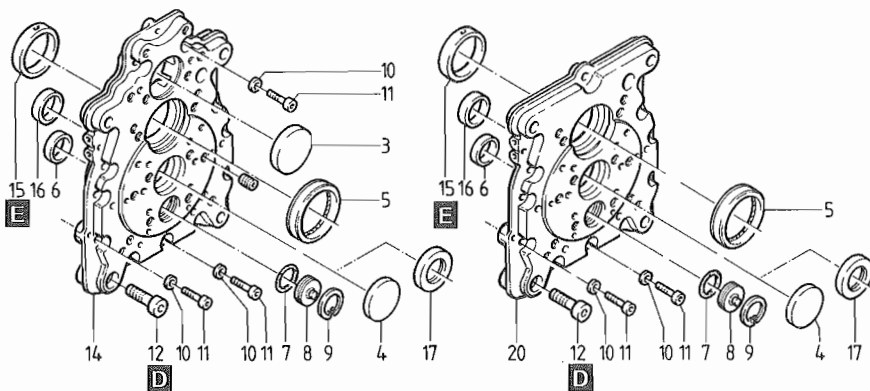

Fig.- No.	HATZ Ident-No.	Stück Qty.				P / W d / D	Bemerkungen Notes
		1D20	1D30	1D60	1D80		
			1D40				
			A1D35				
			A1D40				
1	50328000	5	5	5	5		AM 6 x 16 WN 17065
2	03797411	1	1	1	1		
3	01242401	1	1	1	1		
4	03797300	1	1	1	1		
5	04052800	1	1	1	1		Ø 1,6 mm ...1500 min ⁻¹
5	04052900	1	1	1	1		Ø 1,7 mm 1501...1800 min ⁻¹
5	04008801	1	1	1	1		Ø 1,9 mm 1801...2300 min ⁻¹
6	04070800	1	1	1	1		Ø 2,6 mm 2301...2500 min ⁻¹
6	04008902	1	1	-	-		Ø 3,0 mm 2501...3000 min ⁻¹
6	04063400	-	-	1	1		Ø 2,9 mm 2301...3000 min ⁻¹
5	04008801	1	1	1	1		Ø 1,9 mm 3001...3600 min ⁻¹
6	04008902	1	1	-	-		Ø 3,0 mm 3001...3600 min ⁻¹
6	04063400	-	-	1	1		Ø 2,9 mm 3001...3600 min ⁻¹
7	03798600	1	1	1	1		
8	50334700	1	1	1	1	5	DIN 6799
9	03797600	1	1	1	1		
10	03797510	1	1	1	1		
11	03797701	1	1	1	1		
12	03798002	1	1	1	1		
13	03798102	1	1	1	1		
14	03797900	1	1	1	1		
15	03797801	1	1	1	1		
16	50081200	5	5	5	5	A 6	DIN 137-A3C
17	50170800	3	3	3	3	M 6 x 25	DIN 912-8.8
18	50051000	2	2	2	2	M 6 x 30	DIN 912-8.8
19	50084900	2	2	2	2	8 x 12	DIN 7346
20	03798710	1	1	1	1		
21	50260501	2	2	2	2	2 x 10	DIN 1481
22	04046000	0...3	0...3	0...3	0...3	0,5 mm	

M 11 Steuerdeckel
Timing cover
Couvercle distribution
Tapa de mando
Coperchio distribuzione

Tafel Nr.
Tabl. No.
Tavola N.

11



2 (3,5-6,14-17)

19 (5-6,15-17,20)

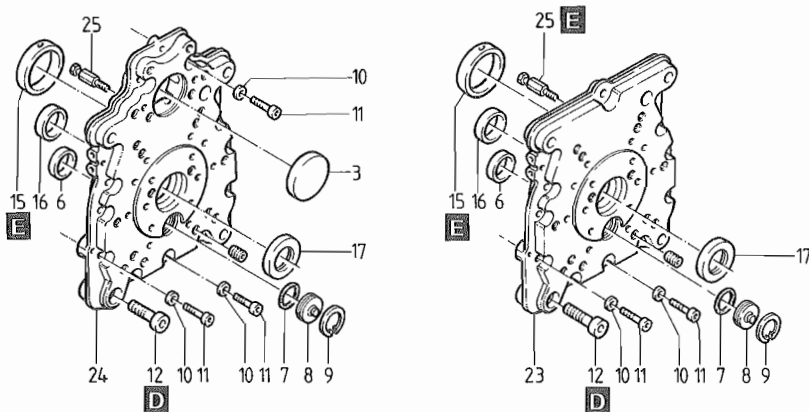

22 (3,6,15-17,24,25)

21 (6,15-17,23,25)

Fig.- No.	HATZ Ident-No.	Stück Qty.				P / W d / D	Bemerkungen Notes
		1D20	1D30	1D60	1D80		
			1D40				
			A1D35				
			A1D40				
1	-----	-	-	-	-		
2	01267710	-	-	1	1		SAE, HP, FP
3	50325600	-	-	1	1		50
4	50325700	1	1	1	1		52
5	50325810	1	1	1	1	D1	54 x 70 x 8
6	03797600	1	1	1	1		
7	50330400	1	1	1	1	D1	27 x 2
8	04000400	1	1	1	1		
9	50399000	1	1	1	1		JL 32 x 1,2 DIN 472
10	50095100	12	12	13	13		A 8 DIN 137-A3C
11	50175900	12	12	13	13		M 8 x 30 DIN 912-8.8 A3C
12	50329500	1	1	1	1		M 12 x 40 DIN 6912-8.8 A3C
14	-----	-	-	-	-		
15	04000310	1	1	1	1		
16	04023201	1	1	1	1		
17	50364700	1	1	1	1		32 x 52 x 7
18	-----	-	-	-	-		
19	01293400	1	1	-	-		SAE, HP, FP
20	-----	-	-	-	-		
21	01280900	1	1	-	-		„T-U“ ITALIA
22	01281000	-	-	1	1		„T-U“ ITALIA
23	-----	-	-	-	-		
24	-----	-	-	-	-		
25	04052400	1	1	1	1		„T-U“

Fig.- No.	HATZ Ident-No.	Stück Qty.				P / W d / D	Bemerkungen Notes
		1D20	1D30	1D60	1D80		
			1D40				
			A1D35				
			A1D40				
1	50331500	1	1	1	1		
2	04000900	1	1	1	1		
3	50050600	1	1	-	-		M 6 x 12 DIN 912-8.8
3	50050700	-	-	1	1		M 6 x 16 DIN 912-8.8
4	50390200	0...1	0...1	0...1	0...1		17 x 1,1
4	50363400	0...1	0...1	0...1	0...1		17 x 1,2
5	04011700	1	1	1	1		
6	03209400	0...1	0...1	0...1	0...1		0,10 mm
7	03209500	0...1	0...1	0...1	0...1		0,15 mm
8	03209600	0...1	0...1	0...1	0...1		0,20 mm
9	03209700	0...1	0...1	0...1	0...1		0,30 mm
10	03209800	0...1	0...1	0...1	0...1		0,50 mm
11	50383500	1	1	-	-		
11	50395800	-	1	-	-		1D35
11	50362410	-	-	1	1		
12	-----	-	-	-	-		
13	50148000	3	3	3	3		M 8 DIN 934-8 A3C
14	-----	-	-	-	-		
15	01268201	1	1	-	-		
15	01245720	-	-	1	1		
16	04025800	1	1	-	-	d1	
16	40085001	-	-	1	1	d1	
17	-----	1	-	-	-		
17	50365200	-	1	-	-		
17	50383300	-	-	1	-		
17	50357100	-	-	-	1		
18	-----	1	-	-	-	P1	
18	50383200	-	1	-	-	P1	
18	50383400	-	-	1	-	P1	
18	50362500	-	-	-	1	P1	
19	-----	-	-	-	-		
20	03792400	1	1	1	1		
21	04035700	1	1	1	1		
22	50000800	2	2	2	2	d2	A 6,5 x 9,5 DIN 7603-Cu
23	-----	-	-	-	-		
24	50333400	1	1	1	1		
25	50313000	1	1	1	1		M 6

Fig.- No.	HATZ Ident-No.	Stück Qty.				P / W d / D	Bemerkungen Notes
		1D20	1D30	1D60	1D80		
			1D40				
			A1D35				
			A1D40				
26	50279200	1	1	-	-		M 8 x 40 DIN 835-8.8 A3C
26	50038400	-	-	1	1		M 8 x 35 DIN 835-8.8 A3C
27	50004600	1	1	1	1		AM 8 x 16 DIN 916-45H
28	04001300	1	1	1	1		
29	01243700	1	1	1	1		
30	50117200	1	1	1	1		4 DIN 6799
31	50123200	1	1	1	1		5 x 10 x 0,5 DIN 988
32	50335400	1	1	1	1	D1	4,7 x 1,6
33	04001000	1	1	1	1		
34	04001200	1	1	1	1		
35	-----	-	-	-	-		
36	50328900	2	2	2	2	D2	22 x 1,6
37	04001401	1	1	1	1		
38	04001600	1	1	1	1		
39	50330800	1	1	1	1		M 16 x 1,5 DIN 908-5.8 A3C
40	50001100	2	2	2	2	D2	A 12 x 15,5 DIN 7603-Cu
41	50015800	1	1	1	1		NW 6
42	03662300	1	1	1	1		
43	03664200	1	1	-	-		4,5 x 2,5 - 130 mm
43	03807100	-	1	1	1		1 D 35, 4,5 x 2,5 - 150 mm
43	04060400	-	1	1	1		„C“, 4,5 x 2,5 - 100 mm
44	00805500	1	1	1	1	P1	
45	03807100	1	1	1	1		4,5 x 2,5 - 150 mm
45	04060200	-	1	1	1		„C“, 4,5 x 2,5 - 55 mm
46	03989600	1	1	1	1		„S-Z, T-U“
46	50157800	-	1	1	1		„C“, N 3
47	03961500	-	1	-	-		1D35, 3,5 x 2,5 - 320 mm
47	03962100	1	1	1	1		3,5 x 2,5 - 160 mm
47	03899200	-	1	-	-		„C“, 3,5 x 2,5 - 270 mm
47	03902000	-	-	1	1		„C“, 3,5 x 2,5 - 390 mm
48	04089700	-	1	-	-		„C“, 4,5 x 2,5 - 530 mm
48	05029600	-	-	1	1		„C“, 4,5 x 850
49	50279600	-	1	1	1		„C“

Startfüllung
 Extra fuel device
M 12 Sucharge
 Sobre aliment.-arranque
 Supplimento

Einspritzrüstung
 Injection equipment
M 14 Equipement d'injection
 Equipo de inyección
 Equipaggiamento d'iniezione

Tafel Nr.
 Tabl. No.
 Tavola N.
12

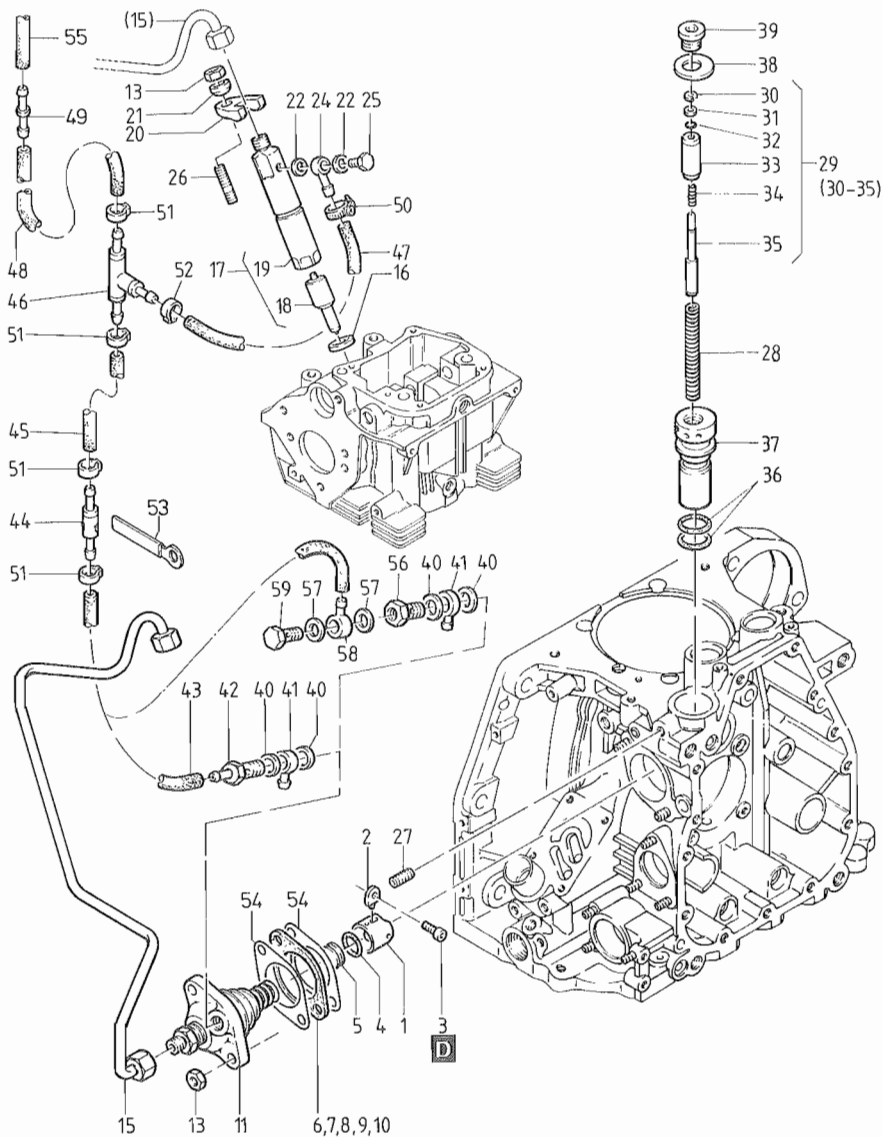

Fig.- No.	HATZ Ident-No.	Stück Qty.				P / W d / D	Bemerkungen Notes
		1D20	1D30	1D60	1D80		
			1D40				
			A1D35				
			A1D40				
50	50357200	-	1	1	1		1D35 „C“, 7 - 11
51	50399800	-	4	4	4		„C“
52	50399900	-	1	1	1		„C“
53	01459700	1	1	1	1		
54	04071300	2	2	2	2	D2	
55	-----	-	-	-	-		
56	03407700	-	1	-	-		„C“
57	50000900	-	2	-	-		„C“ A8 x 11,5 DIN 7603 - Cu
58	50015700	-	1	-	-		„C“ NW3
59	50006100	-	1	-	-		„C“ 4-5-3 DIN 7643

M 26

Luffführung – S, Z, T, U
Air ducting – S, Z, T, U
Carter ventilation – S, Z, T, U
Conducción de aire – S, Z, T, U
Carter ventilatore – S, Z, T, U

Tafel Nr.
Tabl. No.
Tavola N.

13

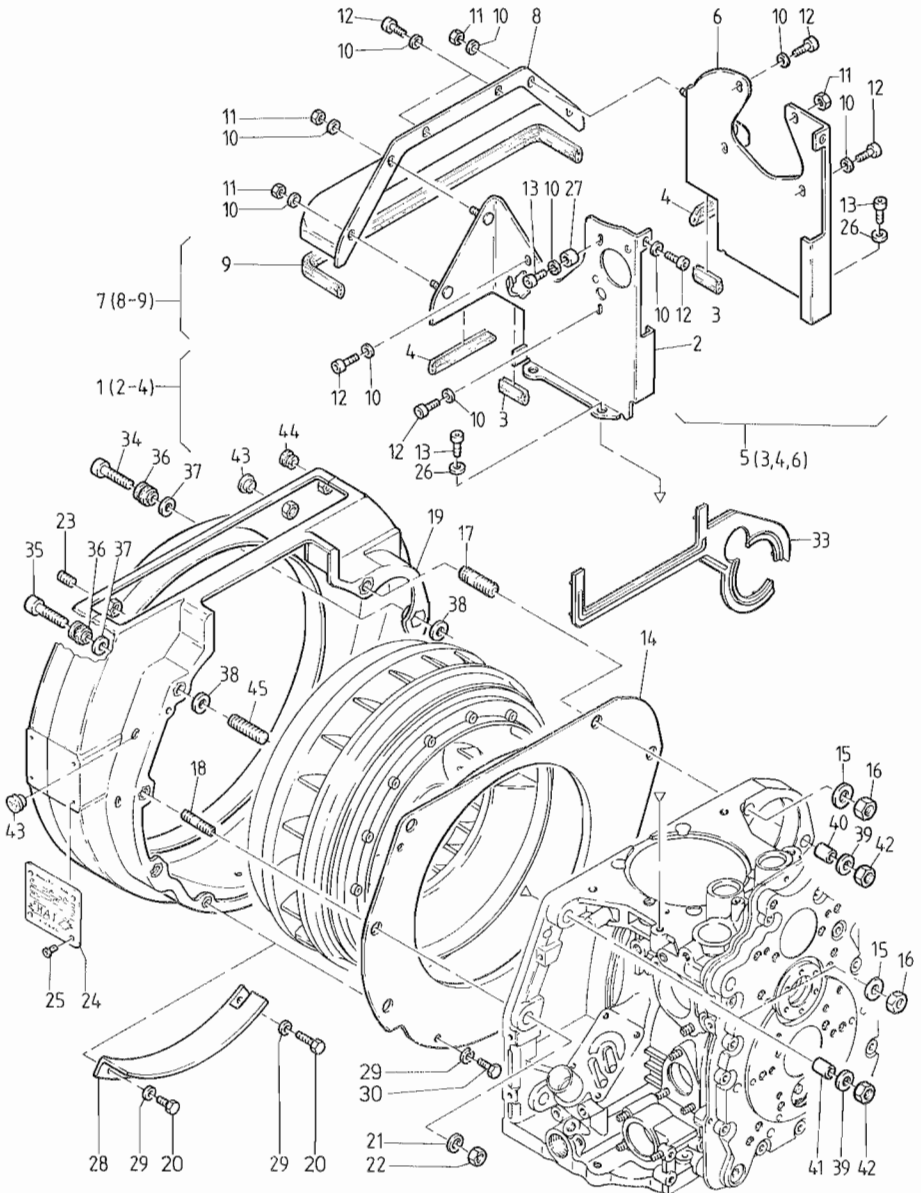

Fig.- No.	HAITZ Ident-No.	Stück Qty.				P / W d / D	Bemerkungen Notes
		1D20	1D30	1D60	1D80		
			1D40				
			A1D35				
			A1D40				
1	01260910	1	1	-	-		
1	01246220	-	-	1	1		
2	-----	-	-	-	-		
3	04030901	2	2	-	-		29 mm
3	04007601	-	-	2	2		35 mm
4	04030801	2	2	-	-		44 mm
4	04007720	-	-	2	2		76 mm
5	01261000	1	1	-	-		
5	01246411	-	-	1	1		
6	-----	-	-	-	-		
7	01261100	1	1	-	-		
7	01246600	-	-	1	1		
8	-----	-	-	-	-		
9	04031001	1	1	-	-		308 mm
9	04007901	-	-	1	1		406 mm
10	50081200	13	13	15	15		A 6 DIN 137 A3C
11	50144400	5	5	4	4		M 6 DIN 934-8 A3C
12	50149100	10	10	12	12		M 6 x 12 DIN 912-8.8 A3C
13	50170700	5	5	-	-		M 6 x 16 DIN 912-8.8 A3C
13	50206300	-	-	4	4		M 8 x 18 DIN 912-8.8 A3C
14	04008500	-	-	1	1		S-Z
15	50093700	-	-	3	3		13 DIN 125-St A3C
16	50093600	-	-	3	3		M 12 DIN 934-8-13-A3C
17	50364900	-	-	2	2		M 12 x 40 DIN 938-8.8 A3C
18	50130000	-	-	3	3		M 8 x 35 DIN 938-8.8
19	01282310	1	1	-	-		E-Start, el. starter, demarreur el., arancador el.
19	01282101	1	1	-	-		Handstart, demarr. man.
19	01255910	-	-	1	1		s. Taf., Tabl. 28 - Pos. 18
20	50333500	-	-	2	2	„T-U“	M 6 x 8 DIN 933-8.8 A3C
21	04065100	-	-	3	3		9,1 x 20 x 2,1
22	50148000	-	-	3	3		M 8 DIN 934-8 A3C
23	50226000	4	4	-	-		M 8 x 6 DIN 913-45H
24	03225504	1	1	1	1		
25	40002500	4	4	4	4		
26	50144500	4	4	-	-		6,4 DIN 125-St A3C
27	03936400	1	1	-	-		6,2 x 8 x 5,5

M 26

Luffführung – S, Z, T, U
Air ducting – S, Z, T, U
Carter ventilation – S, Z, T, U
Conducción de aire – S, Z, T, U
Carter ventilatore – S, Z, T, U

Tafel Nr.
Tabl. No.
Tavola N.

13

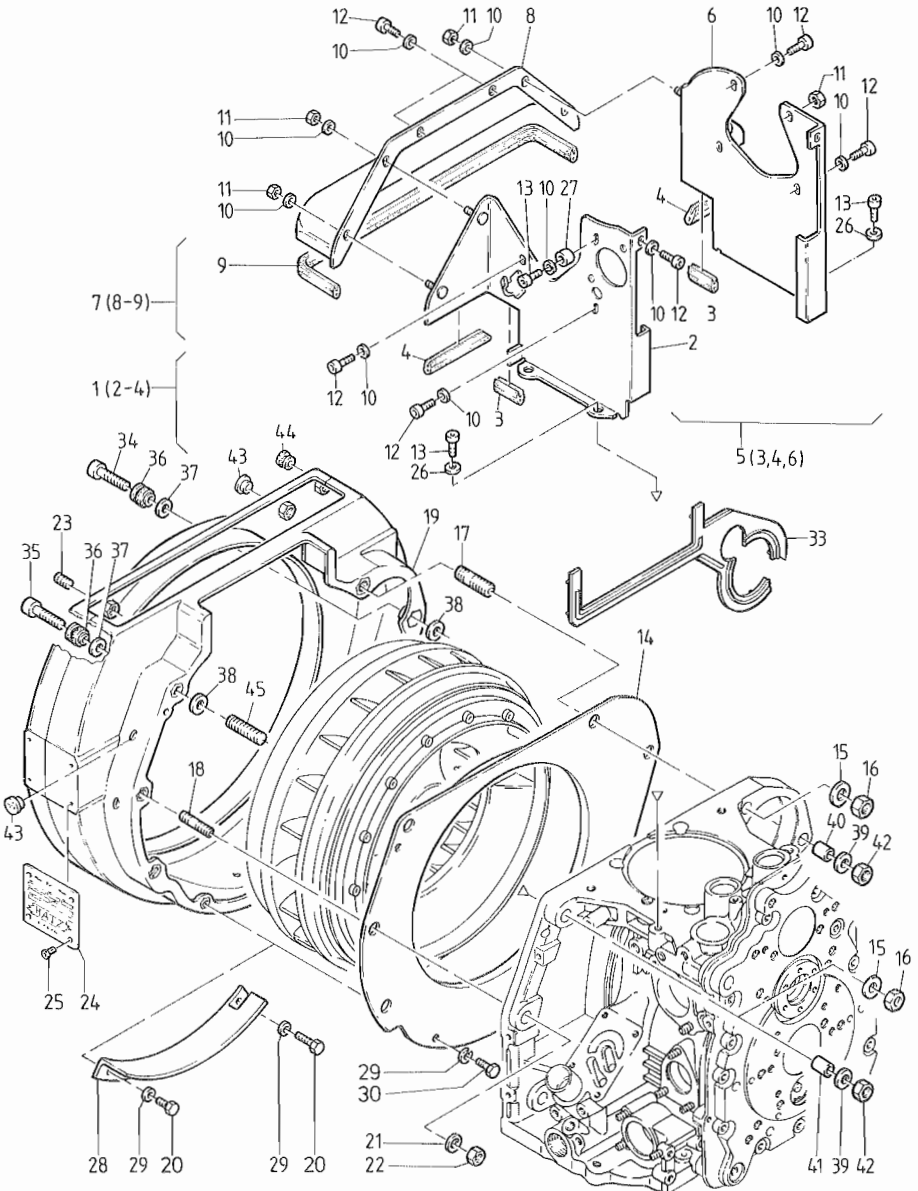

Fig.- No.	HATZ Ident-No.	Stück Qty.				P / W d / D	Bemerkungen Notes
		1D20	1D30	1D60	1D80		
			1D40				
			A1D35				
			A1D40				
28	04080400	-	-	1	1		„T-U“
29	50170900	-	-	2	2		„S-Z“, 6,4 DIN 128-St A3C
30	50165500	-	-	2	2		„S-Z“, M6x12 DIN 933-8.8 A3C
31	-----	-	-	-	-		
32	-----	-	-	-	-		
33	04058600	1	1	-	-		
34	50288800	3	3	-	-		M 8 x 55 DIN 912-8.8 A3C
35	50392900	2	2	-	-		M 8 x 50 DIN 912-8.8 A3C
36	01292200	5	5	-	-		
37	04064700	5	5	-	-		
38	04054300	5	5	-	-		8,4 x 21 x 3
39	04065100	8	8	-	-		9,1 x 20 x 2,1
40	04056500	2	2	-	-		8,4 x 12,8
41	04054400	3	3	-	-		8,4 x 10,8
42	50148000	5	5	-	-		M 8 DIN 934-8 A3C
43	50395700	-	-	4	4		15
44	50334800	-	-	4	4		
45	50197500	-	-	1	1		M 12 x 35 DIN 938-8.8 A3C

Luftführung – A1D35 - 40
 Air ducting – A1D35 - 40
M 26 Carter ventilation – A1D35 - 40
 Conducción de aire – A1D35 - 40
 Carter ventilatore – A1D35 - 40

Tafel Nr.
 Tabl. No.
 Tavola N.

14

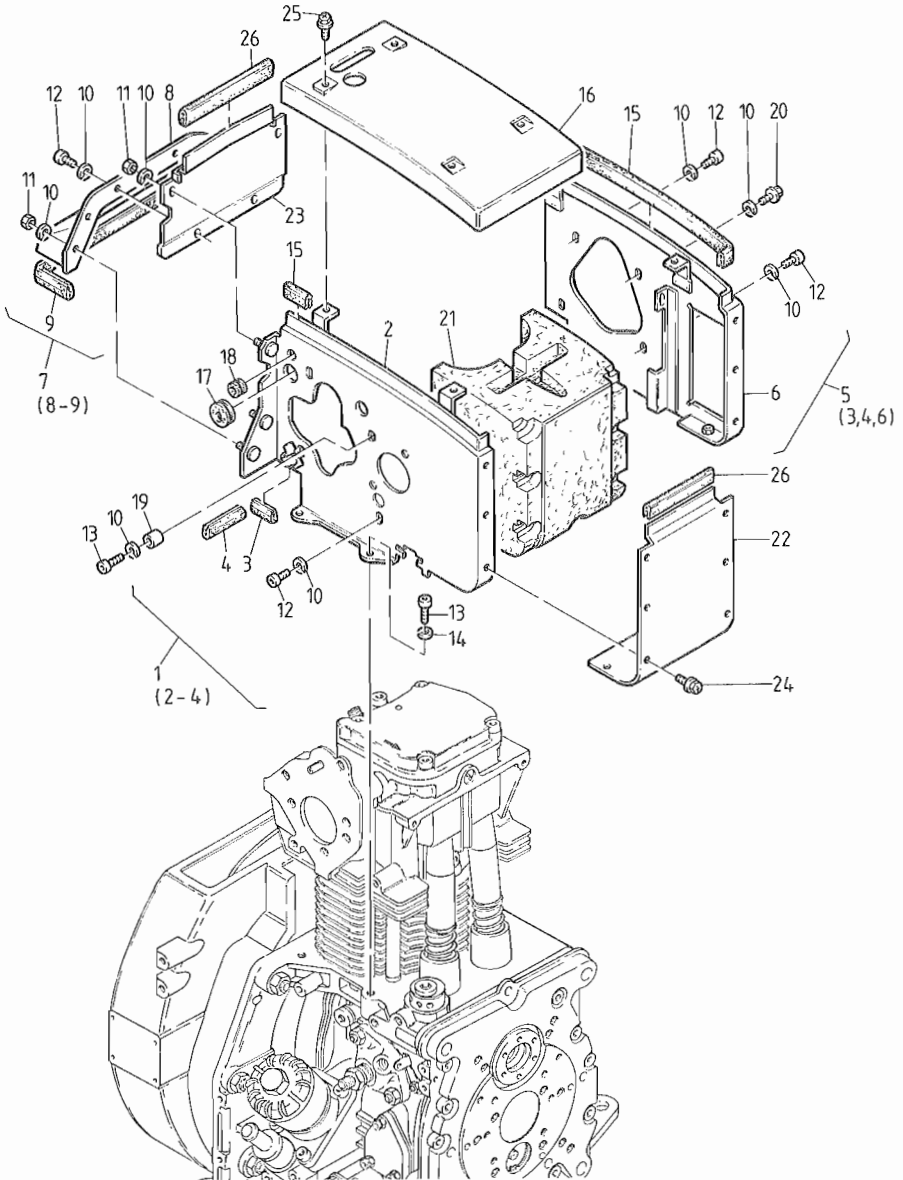

Fig.- No.	HATZ Ident-No.	Stück Qty.	P / W d / D	Bemerkungen Notes
		A1D35		
		A1D40		
1	01288510	1		
2	-----	-		
3	04030901	2		29 mm
4	04030801	2		44 mm
5	01288600	1		
6	-----	-		
7	01261100	1		
8	-----	-		
9	04031001	1		308 mm
10	50170900	15		6 DIN 934-8 A3C
11	50144400	7		M 6 DIN 934-8 A3C
12	50149100	7		M 6 x 12 DIN912-8.8 A3C
13	50170700	5		M 6 x 16 DIN 912-8.8 A3C
14	50144500	4		6,4 DIN 125-St A3C
15	04061701	2		260 mm
16	04056400	1		
17	04060700	1		20 / 25
18	50392800	1		11 / 14
19	03936400	1		6,2 x 8 x 5,5
20	50384200	1		M 6 x 12 Tuflok
21	04086600	1		
22	04058200	1		
23	04064400	1		
24	50289200	8		M 6 x 12 KZ1
25	50335600	4		M 6 x 16 KZ1
26	04061601	2		116 mm

M 26

Luftführung – C
Air ducting – C
Carter ventilation – C
Conducción de aire – C
Carter ventilatore – C

Tafel Nr.
Tabl. No.
Tavola N.

15

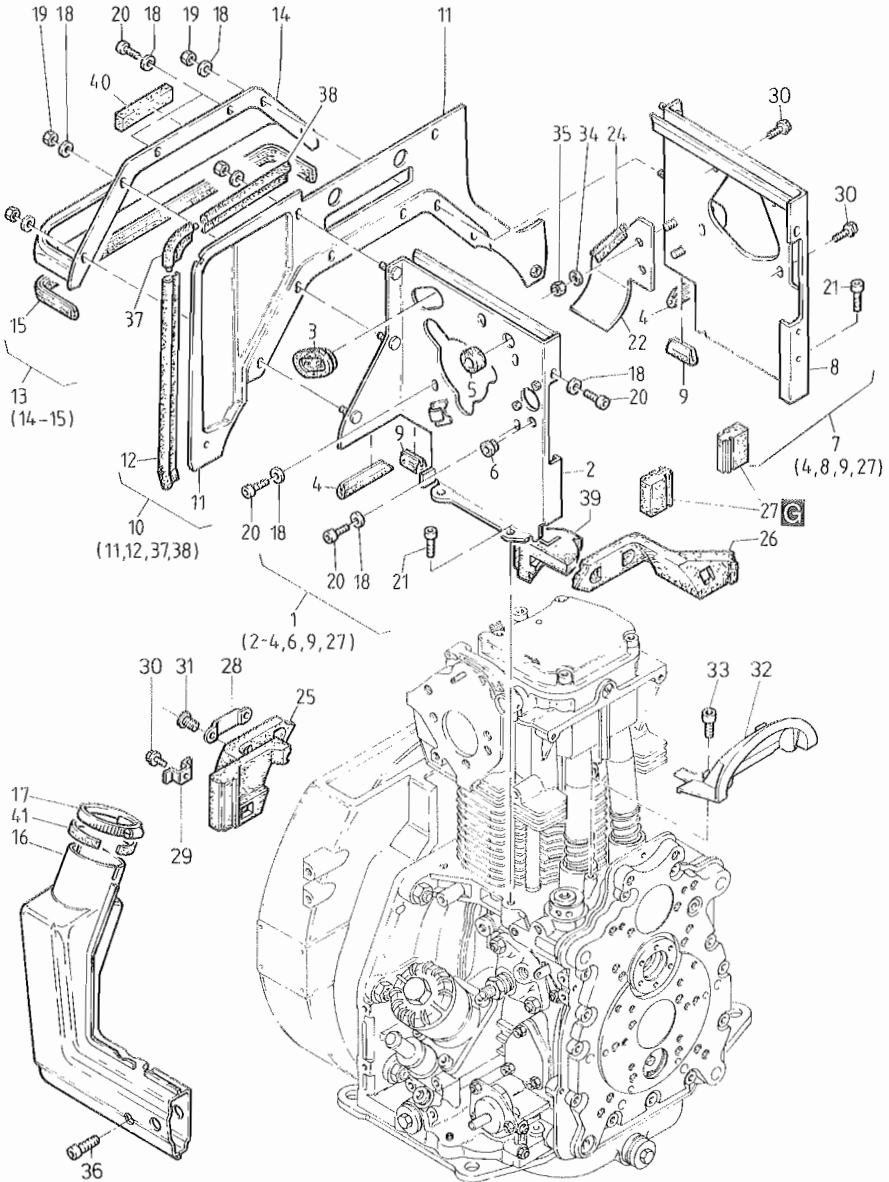

Fig.- No.	HATZ Ident-No.	Stück Qty.	P / W d / D	Bemerkungen Notes
		1D30 C	1D60 C	
		1D40 C	1D80 C	
1	01290800	1	-	
1	01279010	-	1	
2	-----	-	-	
3	04078600	1	-	
3	04055300	-	1	
4	04030801	2	-	
4	04007720	-	2	76 mm
5	04055401	-	1	
6	50334800	1	1	
7	01290700	1	-	
7	01278920	-	1	
8	-----	-	-	
9	04030901	2	-	29 mm
10	01290600	1	-	
10	01278710	-	1	
11	-----	-	-	
12	04066900	1	1	244 mm
13	01290400	1	-	
13	01277301	-	1	
14	-----	-	-	
15	04031000	1	-	308 mm
15	04056301	-	1	347 mm
16	01307600	1	-	
16	01274502	-	1	
17	40071500	1	1	32 - 50
18	50081200	13	13	A 6 DIN 137 A3C
19	50144400	4	4	M 6 DIN 934-8A3C
20	50149100	7	7	M 6 x 12 DIN 912-8.8 A3C
21	50206300	-	4	M 8 x 18 DIN 912-8.8 A3C
22	01309800	1	-	
22	01268010	-	1	
23	-----	-	-	
24	04085500	1	-	65 mm
24	04038800	-	1	94 mm
25	04075500	1	-	
25	04045010	-	1	
26	04075400	1	-	
26	04044610	-	1	
27	04045900	-	2	

M 26

Lufführung – C
Air ducting – C
Carter ventilation – C
Conducción de aire – C
Carter ventilatore – C

Tafel Nr.
Tabl. No.
Tavola N.

15

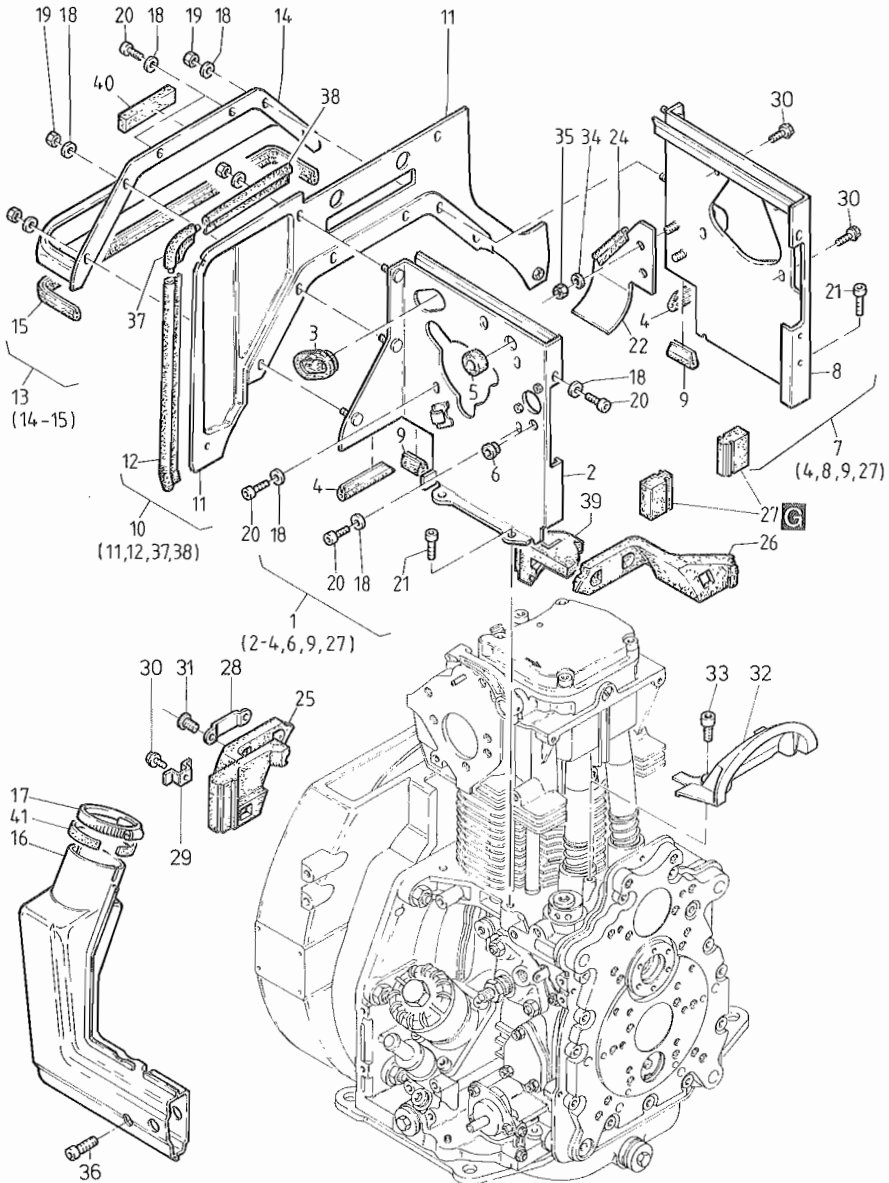

Fig.- No.	HATZ Ident-No.	Stück Qty.	P / W d / D	Bemerkungen Notes
		1D30 C	1D60 C	
		1D40 C	1D80 C	
28	04044900	-	2	
29	04075600	4	-	
29	04044800	-	2	
30	50335600	-	4	M 6 x 16
31	04044700	-	4	M 8 x 16
32	01272100	-	1	
33	50335600	-	2	M 6 x 16 KZ1
34	50120000	2	2	A 6,4 DIN 9021-St A3C
35	50328300	2	2	VM 6 DIN 980-8 A3C
36	50170600	1	1	M 6 x 20 DIN 912-8.8 A3C
37	04066400	1	1	
38	04074900	1	-	90 mm
38	04066700	-	1	104 mm
39	04079600	1	-	
40	04087700	1	-	12 x 6 x 58
41	04089100	1	-	13 x 1 x 148
41	04089200	-	1	13 x 1 x 167

M 30 Aufzugvorrichtung
Lifting bracket
Etrier 1D35
Estribo
Anello di trasporto

M 31 Entlüftung
Breather
Purge d'air
Purga de aire
Sfiatatoio

M 32 Drehzahlverst.
Speed control
Réglage régime
Ajuste de revoluc.
Regolatore di giri

Tafel Nr.
Tabl. No.
Tavola N.
16.

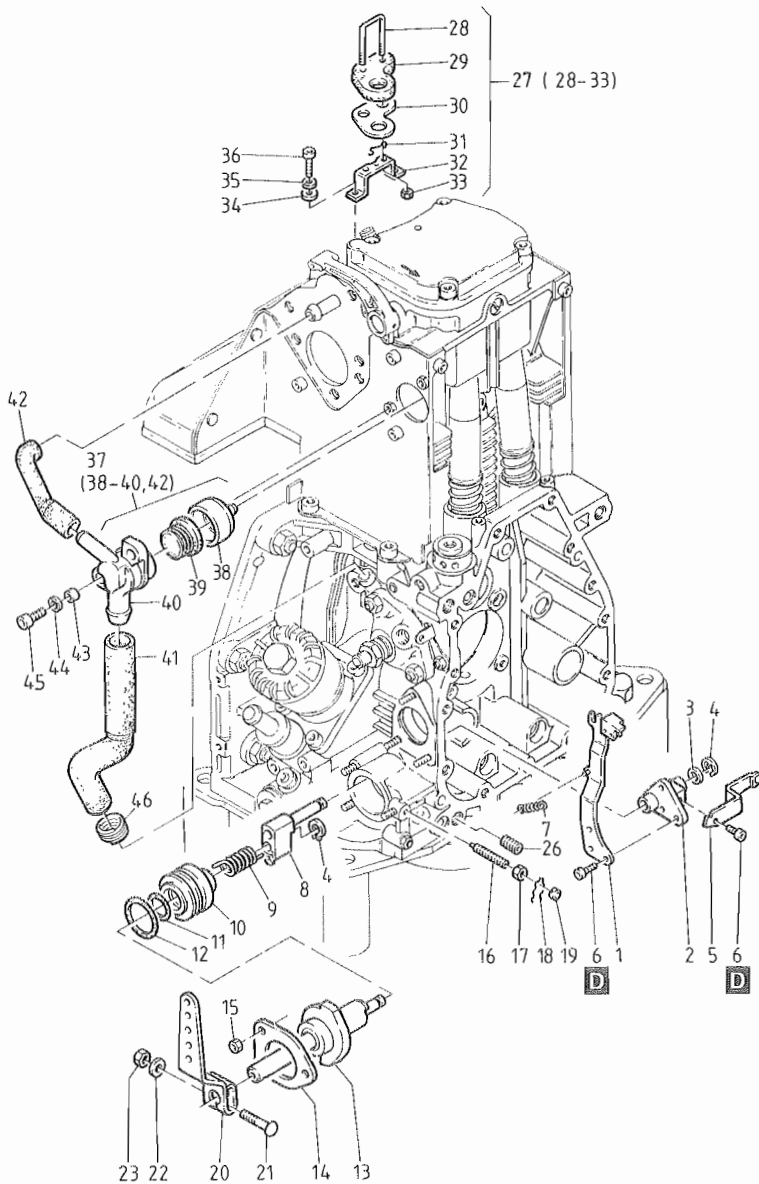

Fig.- No.	HATZ Ident-No.	Stück Qty.				P / W d / D	Bemerkungen Notes
		1D20	1D30 1D40 A1D35 A1D40	1D60	1D80		
1	01242900	1	1	1	1		
2	01243000	1	1	1	1		
3	04000100	1	1	1	1		
4	50266100	2	2	2	2	6	DIN 6799
5	04037500	1	1	1	1		
6	50328700	4	4	4	4	M 5 x 8	DIN 912-8.8
7	04000200	1	1	1	1		
8	01242810	1	1	1	1		
9	03799010	1	1	1	1		
10	04052700	1	1	1	1		
11	50386100	1	1	1	1		
12	50129900	1	1	1	1	D1	21 x 2 32 x 2,5
13	01279201	1	1	1	1		
13	01302900	1	1	1	1		„C“
14	03799200	1	1	1	1		
15	50328300	3	3	3	3	VM 6	DIN 980-8 A3C
16	03799400	2	2	2	2		
17	50144400	2	2	2	2	M 6	DIN 934-8 A3C
18	40021500	2	2	2	2		
19	40021400	2	2	2	2		
20	03888300	1	1	1	1		
21	03927300	1	1	1	1	M 6 x 32	
22	50144500	1	1	1	1	6,4	DIN 125-St A3C
23	50144400	1	1	1	1	M 6	DIN 934-8 A3C
24	-----	-	-	-	-		
25	-----	-	-	-	-		
26	50403500	1	1	1	1	M 8 x 20	DIN 914-45 H
27	01482201	-	1	-	-	A 1D35 - 40	
28	-----	-	-	-	-		
29	04061100	-	1	-	-		
30	-----	-	-	-	-		
31	-----	-	-	-	-		
32	04061210	-	1	-	-		
33	50328300	-	2	-	-	VM 6	DIN 980-8 A3C
34	50148100	-	2	-	-	8,4	
35	50347300	-	2	-	-	8	DIN 7980 A3C

M 30

Aufzugvorrichtung
Lifting bracket
Etrier 1D35
Estribo
Anello di trasporto

M 31

Entlüftung
Breather
Purge d'air
Purga de aire
Sfiatatoio

M 32

Drehzahlverst.
Speed control
Réglage régime
Ajuste de revoluc.
Regolatore di giri

Tafel Nr.
Tabl. No.
Tavola N.

16

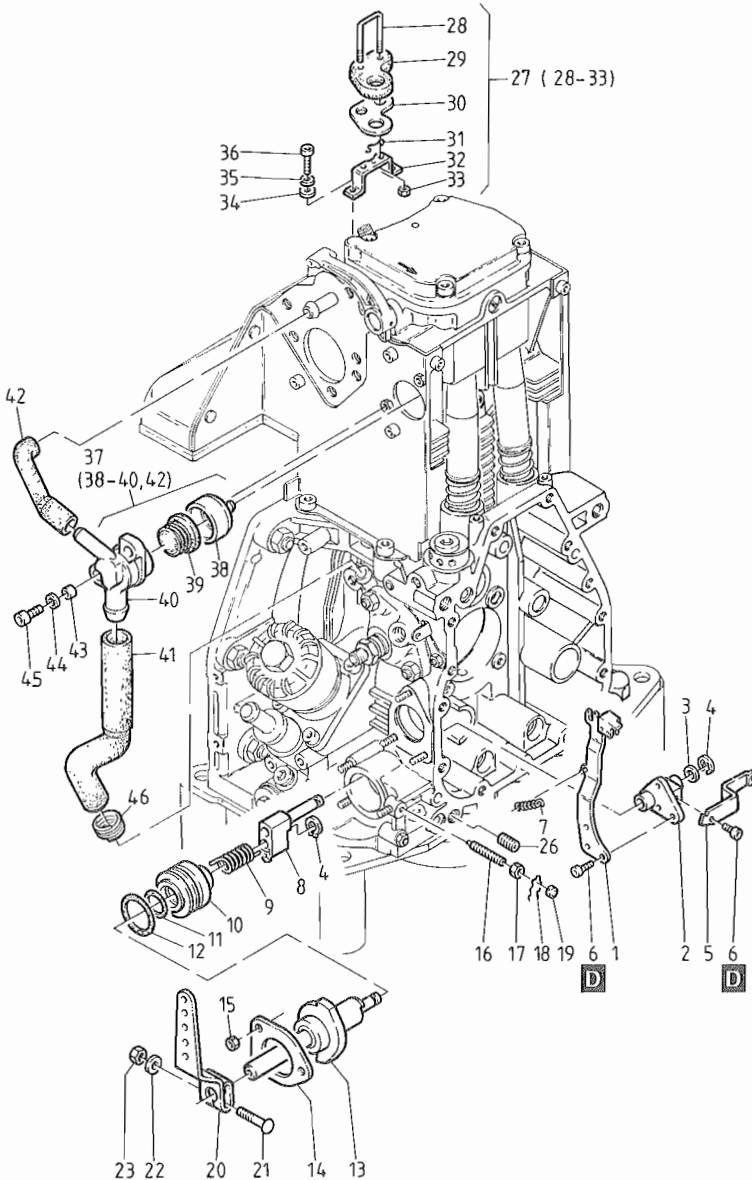

Fig.- No.	HATZ Ident-No.	Stück Qty.				P / W d / D	Bemerkungen Notes
		1D20	1D30	1D60	1D80		
			1D40				
			A1D35				
			A1D40				
36	50175900	-	2	-	-		M 8 x 30 DIN 912-8.8 A3C
37	01308100	1	1	1	1		
38	04080300	1	1	1	1		
39	03568700	1	1	1	1		
40	-----	-	-	-	-		
41	04083800	1	1	-	-		
41	04074700	-	-	1	1		
42	04074800	1	1	1	1		
43	04080500	2	2	2	2		7 x 8 x 8
44	50081200	2	2	2	2		A 6 DIN 137 A3C
45	50170700	2	2	2	2		M 6 x 16 DIN 912-8.8 A3C
46	04090500	1	1	1	1		

M 35

Kapsel – C
Capsule – C
Capsule – C
Cápsula – C
Cofanatura silenziosa – C

Tafel Nr.
Tabl. No.
Tavola N.

17

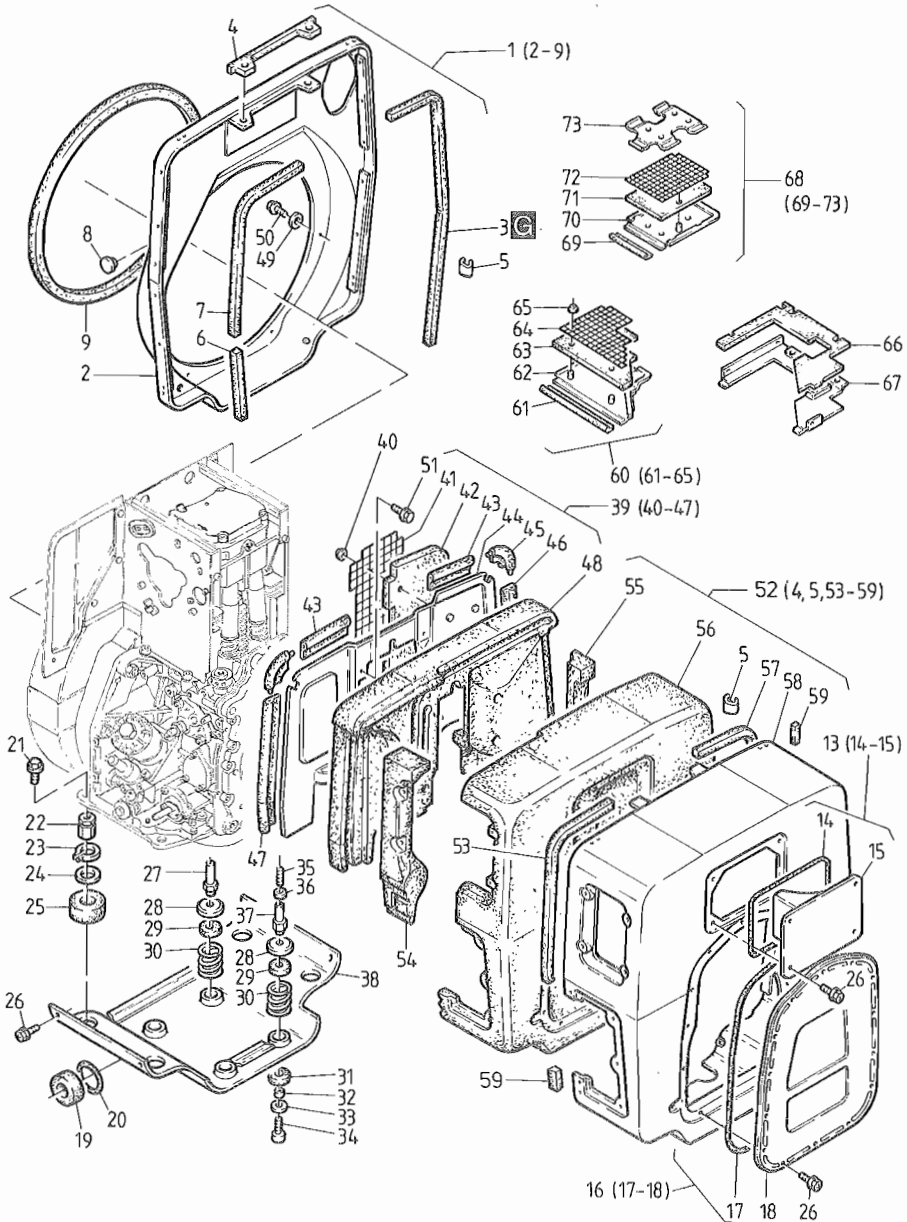

Fig.- No.	HATZ Ident-No.	Stück Qty.	P / W d / D	Bemerkungen Notes
		1D30 C	1D60 C	
		1D40 C	1D80 C	
1	01289100	1	-	
1	01276310	-	1	
2	-----	-	-	
3	04080600	1	-	8 x 8 x 530 mm Silikon
3	04086100	-	1	640 mm
4	04073800	2	2	
5	04084100	8	8	
6		1	-	
6	04086000	-	1	160 mm
7	04081000	1	-	8 x 8 x 530 mm
7	04073500	-	1	420 mm
8	50395500	1	1	17,3
9	04049500	1	1	1230 mm
10	-----	-	-	
11	-----	-	-	
12	-----	-	-	
13	01289500	1	-	
13	01276600	-	1	
14	04049100	1	1	
15	-----	-	-	
16	01289401	1	-	
16	01276700	-	1	
16	01474401	1	-	Handstart, demarr. man.
16	01464200	-	1	Handstart, demarr. man.
17	04080900	1	-	
17	04049000	-	1	
18	-----	-	-	
19	03755300	1	-	46/16
19	03579500	-	1	46/22
20	03592301	1	1	26,1 x 38 x 1
21	50386600	4	4	
22	03993700	4	4	
23	50020400	4	4	A 24 x 1,2 DIN 471
24	03592301	4	4	26,1 x 38 x 1
25	03755300	4	4	
26	50289200	24	26	M6 x 12 KZ1
27	04077400	2	-	
27	04047500	-	2	
28	04042100	4	4	
29	04041900	4	4	

M 35

Kapsel – C
Capsule – C
Capsule – C
Cápsula – C
Cofanatura silenziata – C

Tafel Nr.
Tabl. No.
Tavola N.

17

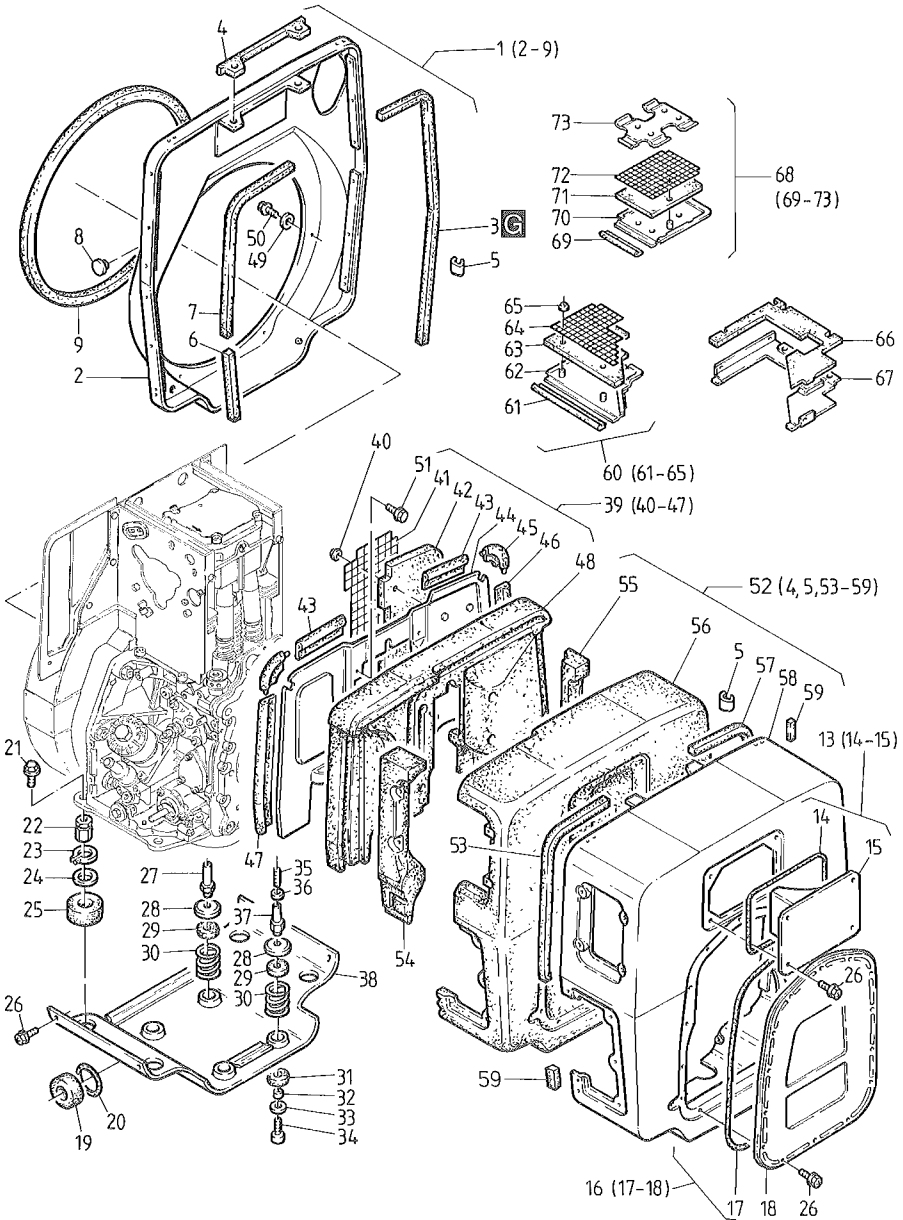

Fig.- No.	HATZ Ident-No.	Stück Qty.	P / W d / D	Bemerkungen Notes
		1D30 C	1D60 C	
		1D40 C	1D80 C	
30	04042200	4	4	
31	04041800	4	4	
32	04041700	4	4	
33	04042000	4	4	6,5 x 22,5 x 1
34	50170600	4	4	M 6 x 20 DIN 912-8.8 A3C
35	50139200	4	4	M 6 x 16 DIN 939-8.8
36	50144500	4	4	6,4 DIN 125-St
37	04077400	2	-	
37	04041600	-	2	
38	01303700	1	-	
38	01270510	-	1	
39	01306300	1	-	
39	01274810	-	1	
40	50388500	4	4	4,5
41	04078100	1	-	
41	04066600	-	1	
42	04078000	1	-	
42	04046710	-	1	
43	04074900	2	-	90 mm
43	04066700	-	2	104 mm
44	-----	-	-	
45	04066400	2	2	
46	04075000	1	-	180 mm
46	04066900	-	1	244 mm
47	04066900	1	-	244 mm
47	04067000	-	1	280 mm
48	01306500	1	-	
48	01279410	-	1	
49	50144500	6	6	6,4 DIN 125 - St A3C
50	50274800	6	6	M 6 x 6 DIN 933-8.8 A3C
51	50335600	2	2	M 6 x 16 KZ1
52	01289300	1	-	
52	01276510	-	1	
53	04081600	1	-	8 x 8 x 360 mm
53	04085800	-	1	410 mm
54	04047210	-	1	
55	04044210	-	1	
56	01305300	1	-	
56	01272610	-	1	

M 35

Kapsel – C
Capsule – C
Capsule – C
Cápsula – C
Cofanatura silenziata – C

Tafel Nr.
Tabl. No.
Tavola N.

17

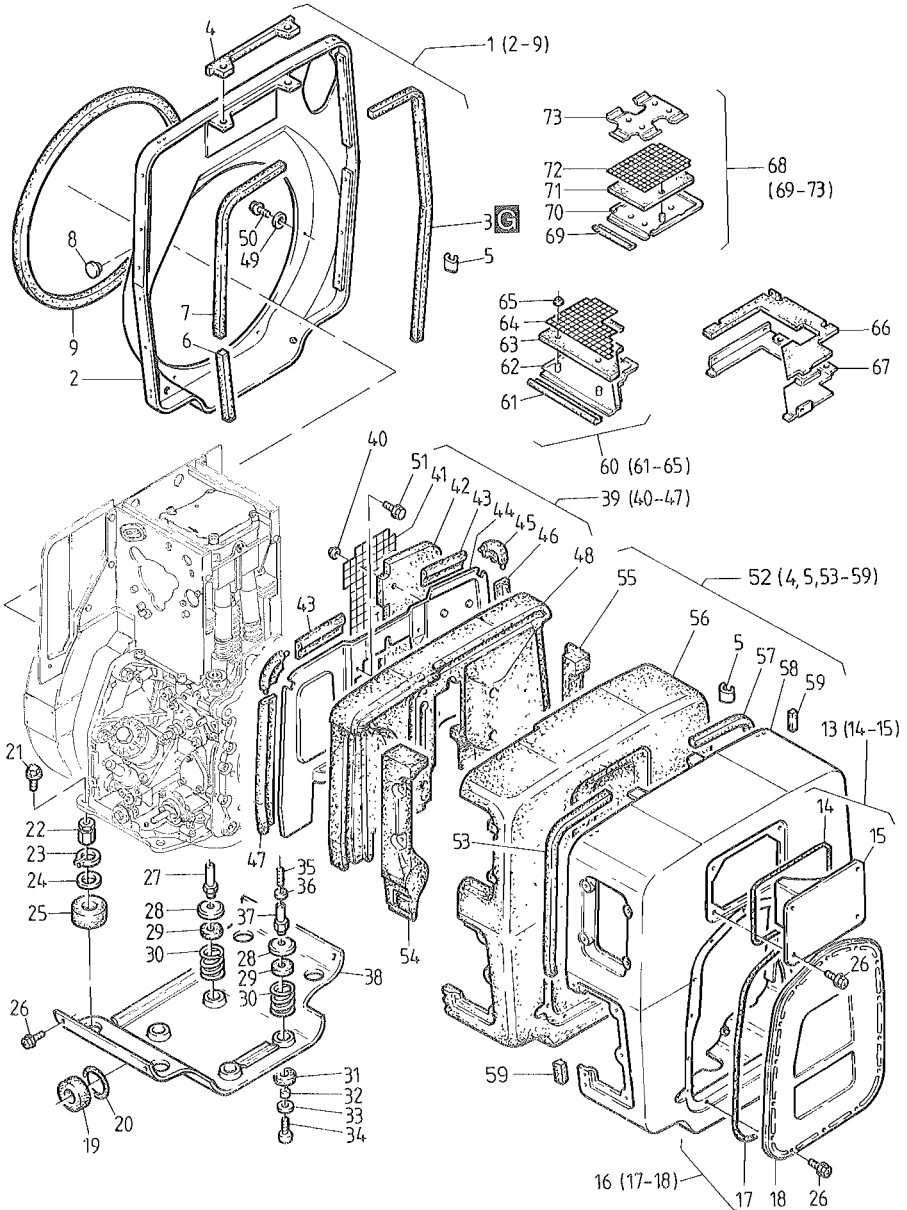

Fig.- No.	HATZ Ident-No.	Stück Qty.	P / W d / D	Bemerkungen Notes
		1D30 C 1D40 C	1D60C 1D80 C	
57	04080700	1	-	8 x 8 x 360
57	04073500	-	1	420 mm
58	-----	-	-	
59	04081700	2	-	8 x 8 x 25 mm
59	04085900	-	1	40 mm
60	01275011	-	1	
61	04049400	-	1	186 mm
62	-----	-	-	
63	-----	-	-	
64	-----	-	-	
65	-----	-	-	
66	04082100	-	1	
67	04081400	-	1	
68	01289200	1	-	
69	04083200	-	1	97 mm
70	-----	-	-	
71	-----	-	-	
72	-----	-	-	
73	-----	-	-	
74	-----	-	-	
75	-----	-	-	

M 35

Kapsel – C
Capsule – C
Capsule – C
Cápsula – C
Cofanatura silenziosa – C

Tafel Nr.
Tabl. No.
Tavola N.

18

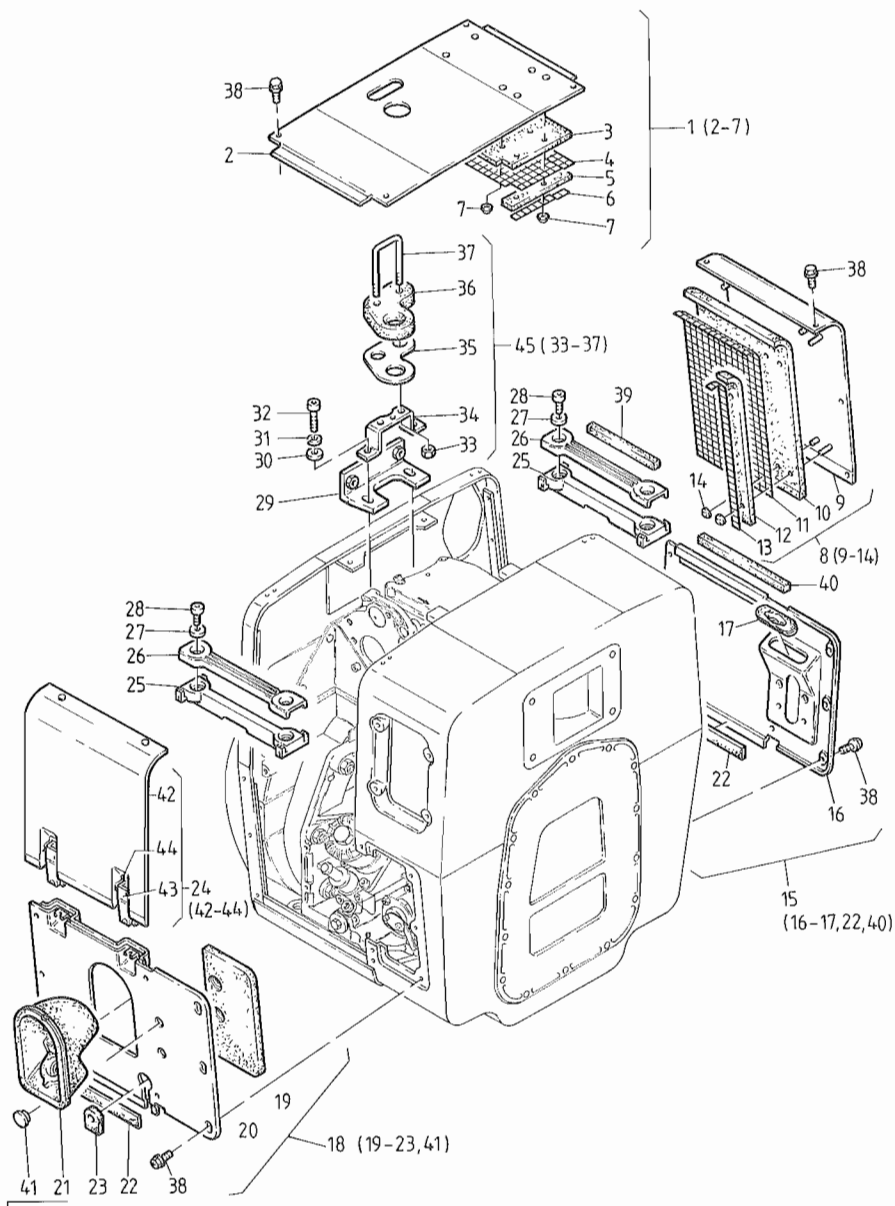

Fig.- No.	HATZ Ident-No.	Stück Qty.	P / W d / D	Bemerkungen Notes
		1D30 C	1D60 C	
		1D40 C	1D80 C	
1	01305500	1	-	
1	01274910	-	1	
2	-----	-	1	
3	04076000	1	-	
3	04046810	-	1	
4	04076300	1	1	
4	04067600	-	1	
5	04076100	1	-	
5	04067700	-	1	
6	04076200	1	-	
6	04066000	-	1	
7	50388500	6	6	4,5
8	01305800	1	-	
8	01274710	-	1	
9	-----	-	-	
10	04076600	1	-	
10	04046610	-	1	
11	04076800	1	-	
11	04067100	-	1	
12	04076700	1	-	
12	04065900	-	1	
13	04076900	1	1	
13	04065800	-	1	
14	50388500	6	6	4,5
15	01290000	1	-	
15	01277010	-	1	
16	-----	-	-	
17	03993100	1	1	
18	01289800	1	-	
18	01276910	-	1	
19	04087600	1	-	
19	04074000	-	1	
20	-----	-	-	

M 35

Kapsel – C
Capsule – C
Capsule – C
Cápsula – C
Cofanatura silenziosa – C

Tafel Nr.
Tabl. No.
Tavola N.

18

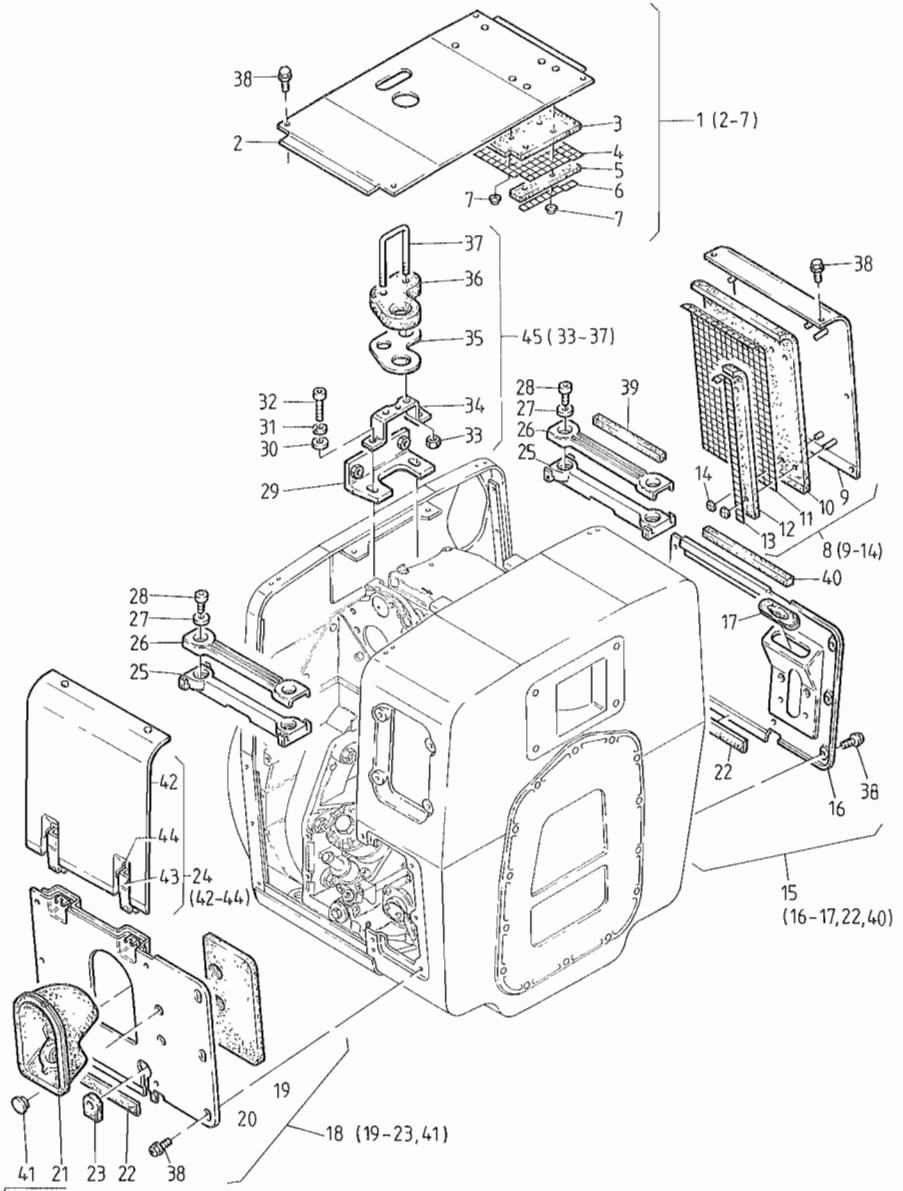

Fig.- No.	HATZ Ident-No.	Stück Qty.	P / W d / D	Bemerkungen Notes
		1D30 C 1D40 C	1D60 C 1D80 C	
21	04076500	1	-	
21	04047010	-	1	
22	04086500	1	-	13 x 1 x 182 mm
22	04049700	-	2	13 x 1 x 195 mm
23	04084700	1	-	
23	04084600	-	1	
24	01289700	1	-	
24	01271010	-	1	
24	04084400	1	-	Dekompr.-Autom.
24	04053510	-	1	Dekompr.-Autom.
25	04077300	2	-	
25	04067900	-	2	
26	01306100	2	-	
26	01300400	-	2	
27	50081200	4	4	A 6 DIN 137
28	50133000	4	4	M 6 x 12 DIN 6912-8.8
29	01307800	1	-	
29	01282710	-	1	
30	50148100	2	2	8,4 DIN 125-StA3C
31	50347301	2	2	VHZ 8
32	50175900	2	2	M 8 x 30 DIN 912-8.8 A3C
33	50328300	2	2	VM 6 DIN 980-8A3C
34	04061210	1	-	
34	04043110	-	1	
35	-----	-	-	
36	04061100	1	-	
36	04043400	-	1	
37	-----	-	-	
38	50289200	26	26	M 6 x 12 KZ 1
39	04077200	1	-	8 x 8 x 122
39	04073700	-	1	8 x 8 x 134
40	04080000	1	-	8 x 8 x 160
40	04073600	-	1	170 mm
41	50395500	2	2	PHT 17,6/20
42	-----	-	-	
43	50393200	2	2	
44	50396100	4	4	2,5 x 8 DIN 660-St
45	01290501	1	-	
45	01462602	-	1	

Kraftstoffbehälter, Filter, Leitungen
 Fuel tank, filter, pipes
 Reservoir à carburant, filtre, conduites
 Depósito combustible, filtro, tubería
 Serbatoio combustibile

Tafel Nr.
 Tabl. No.
 Tavola N.

A 01

19

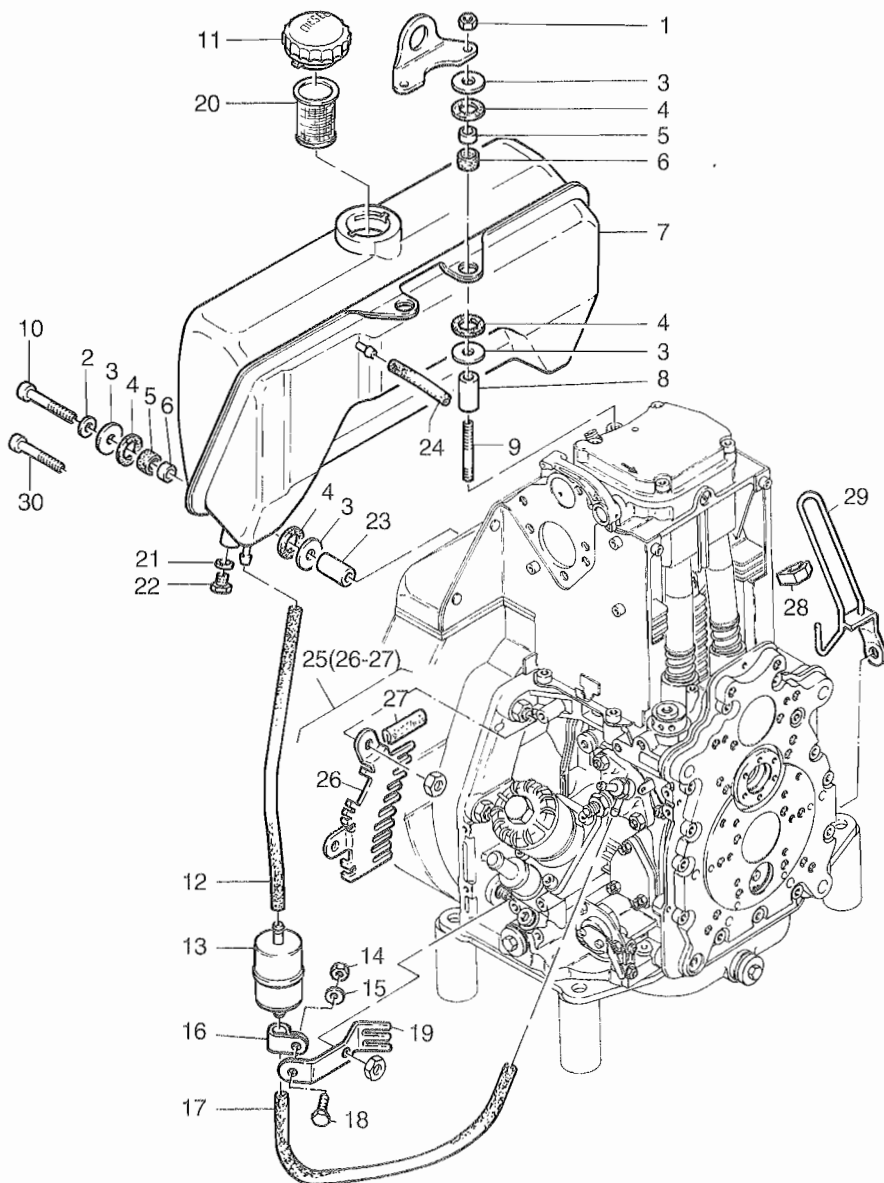

Fig.- No.	HATZ Ident-No.	Stück Qty.				P / W d / D	Bemerkungen Notes
		1D20	1D30 1D40	1D60	1D80		
1	50148000	2	2	2	2	M 8	DIN 934-8 A3C
2	50208500	2	2	4	4	8,4	DIN 128-St A3C
3	50062900	8	8	12	12	B 8,4	DIN 9021-St A3C
4	03981802	8	8	12	12	15-25	
5	03981900	4	4	6	6		
6	03981700	4	4	6	6	8,4 x13 x 7	
7	01405500	1	1	-	-	5 l	
7	01494200	-	-	1	1	7 l	
8	03981500	2	2	-	-	9 x 18 x 49	
8	03989800	-	-	2	2	8,5 x 20 x 49	
9	50377001	2	2	2	2	M 8 x 75	DIN 835-10.9 A3C
10	50171600	2	2	-	-	M 8 x 65	DIN 912-8.8 A3C
10	50177500	-	-	4	4	M 8 x 40	DIN 912-8.8 A3C
11	40032700	1	1	-	-	P1	
11	50385800	-	-	1	1	P1	
12	03493300	1	1	-	-	7 x 140	
12	03801200	-	-	1	1	7 x 220	
13	40089401	1	1	1	1	W2	
14	50144400	1	1	1	1	M 6	DIN 934-8
15	50144500	1	1	1	1	6,4	DIN 125-St A3C
16	03165500	1	1	1	1		
17	03674300	1	1	-	-	7 x 305 mm	
17	03493600	-	-	1	1	7 x 330 mm	
18	50165500	1	1	1	1	M 6 x 12	DIN 933-8.8 A3C
19	05036600	1	1	-	-		
19	05031900	-	-	1	1		
20	40037800	1	1	-	-		
20	50387300	-	-	1	1		
21	50001000	1	1	1	1	A 10 x 16	DIN 7603-Cu
22	50359800	1	1	1	1	M 10 x 12	DIN 933-8.8 A3C
23	03981600	2	2	-	-	9 x 18 x 38	
23	05029200	-	-	4	4	9 x 18 x 8 f. Taf., Tabl. 32-Pos. 9	
24	03663800	1	1	-	-	4,5 x 40 mm	
24	03663700	-	-	1	1	4,5 x 50 mm	
25	01490300	-	-	1	1		
26	-----	-	-	-	-		
27	04030901	-	-	1	1	29 mm	
28	03150900	-	-	1	1		
29	01422000	-	-	1	1		

Kraftstoffbehälter, Filter, Leitungen – A 1D35 - 40

Fuel tank, filter, pipes – A 1D35 - 40

A 01

Reservoir à carburant, filtre, conduites – A 1D35 - 40

Depósito combustible, filtro, tubería – A 1D35 - 40

Serbatoio combustibile – A1D35 - 40

Tafel Nr.

Tabl. No.

Tavola N.

20

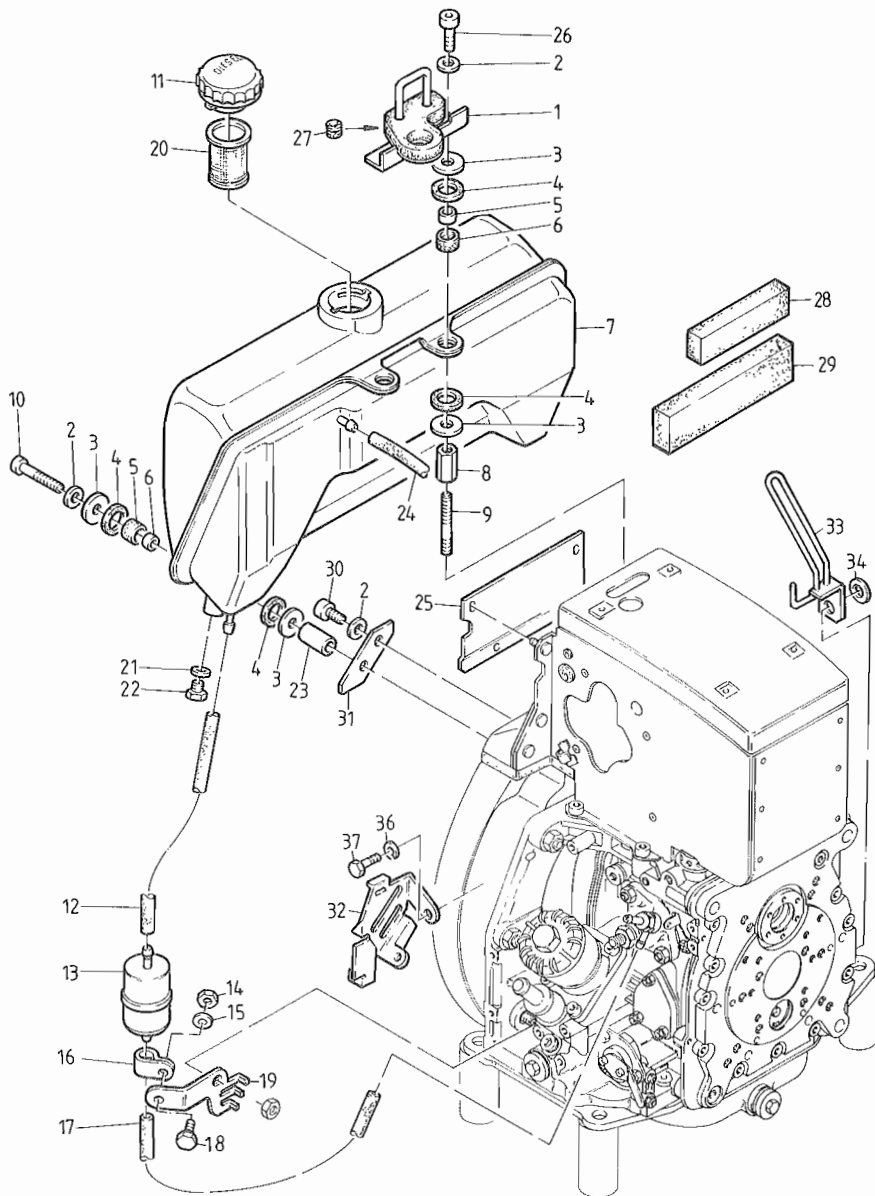

Fig.- No.	HATZ Ident-No.	Stück Qty.	P / W d / D	Bemerkungen Notes
		A1D35 A1D40		
1	01448700	1		
2	50208500	6		8,4 DIN 128-St
3	50062900	8		B 8,4 DIN 9021-St A3C
4	03981802	8		15 - 25
5	03981900	4		
6	03981700	4		8,4 x 13 x 7
7	05011100	1		5 l
8	05010700	2		M 8 – 49 mm
9	50037300	2		M 8 x 18 DIN 835-10.9
10	50171600	2		M 8 x 65 DIN 912-8.8 A3C
11	40032700	1	P1	
12	03493300	1		7 x 140
13	40089401	1	W2	
14	50144400	1		M 6 DIN 934-8
15	50144500	1		6,4 DIN 125-St A3C
16	03165500	1		
17	03674300	1		7 x 305 mm
18	50165500	1		M 6 x 12 DIN 933-8.8 A3C
19	05036600	1		A1D35-40, 1D20-40
20	50387300	1		
21	50001000	1		A 10 x 16 DIN7603-Cu
22	50359800	1		M 10 x 12 DIN 933-8.8 A3C
23	03963310	1		9 x 18 x 30
24	04060200	1		4,5 x 55 mm
25	04063300	1		
26	50175900	2		M 8 x 30 DIN 912-8.8 A3C
27	50163800	2		7012
28	05010800	1		125 mm
29	05010900	1		135 mm
30	50366300	2		M 8 x 20 DIN 912-8.8 A3C
31	05010600	2		
32	05036701	1		A1D35-40, 1D20-40
33	01409000	1		A1D35-40, 1D20-40
34	04065100	1		9,1 x 20 x 2,1
35	-----	-		
36	50170900	1		6 DIN 128-A3C
37	50170700	1		M 6 x 16 DIN 912-8.8 A3C

A 01 Förderpumpe
Fuel feed pump
Pompe alimentation
Bomba alimentacion
Pompa A. C.

Tafel Nr.
Tabl. No.
Tavola N.

21

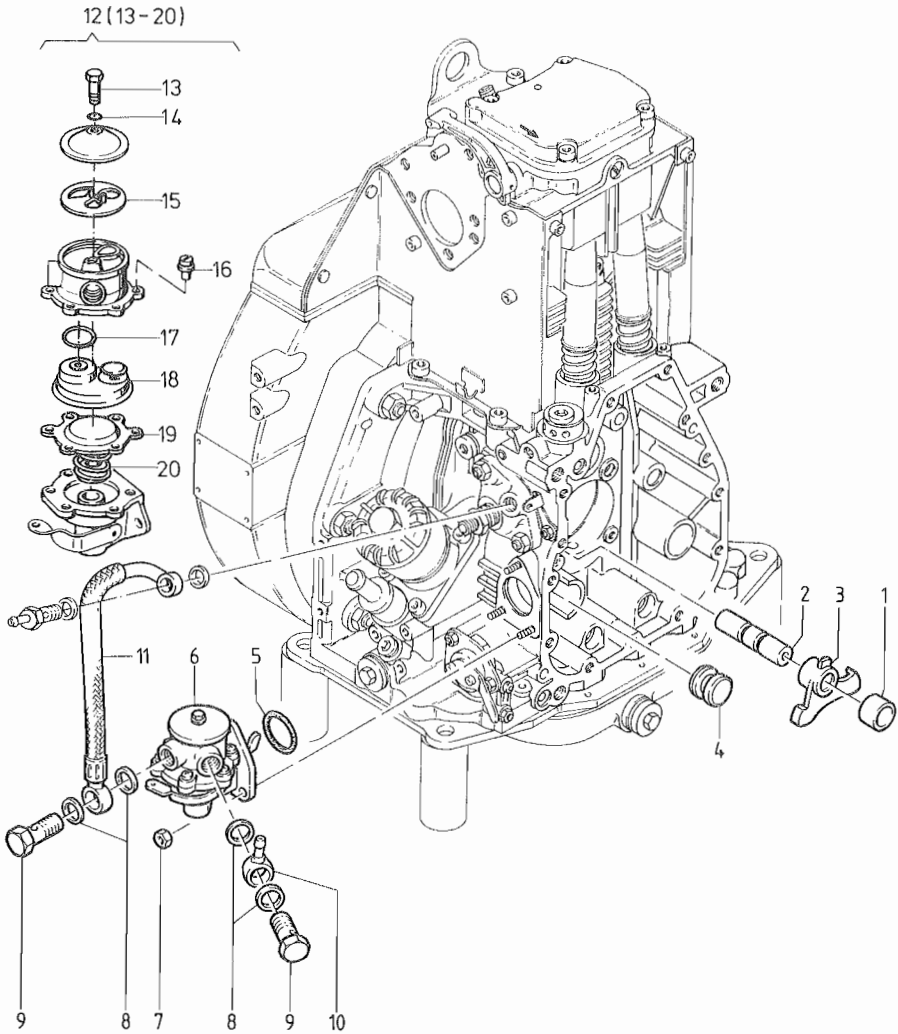

Fig.- No.	HATZ Ident-No.	Stück Qty.				P / W d / D	Bemerkungen Notes
		1D20	1D30	1D60	1D80		
			1D40				
			A1D35				
			A1D40				
1	04011900	1	1	1	1		„S-T“
2	03796400	1	1	1	1		„S-T“
3	04011800	1	1	1	1		
4	04023600	1	1	-	-		
4	04000800	-	-	1	1		
5	50331800	1	1	1	1		35 x 2,8
6	50332300	1	1	1	1		
7	50328300	3	3	3	3		VM8 980-8 A3C
8	50001200	4	4	4	4		A 14 x 18 DIN 7603-Cu
9	50006400	2	2	2	2		10-3 DIN 7643
10	50015900	1	1	1	1		NW 8/6
11	01468800	1	1	1	1		
12	49062500	1	1	1	1		
13	-----	-	-	-	-		
14	-----	-	-	-	-		
15	49061700	1	1	1	1		
16	-----	-	-	-	-		
17	-----	-	-	-	-		
18	-----	-	-	-	-		
19	-----	-	-	-	-		
20	-----	-	-	-	-		

A 02 Luftfilter
 Air filter
 Filtre à air
 Filtro de aire
 Filtro aria

Tafel Nr.
 Tabl. No.
 Tavola N.

22

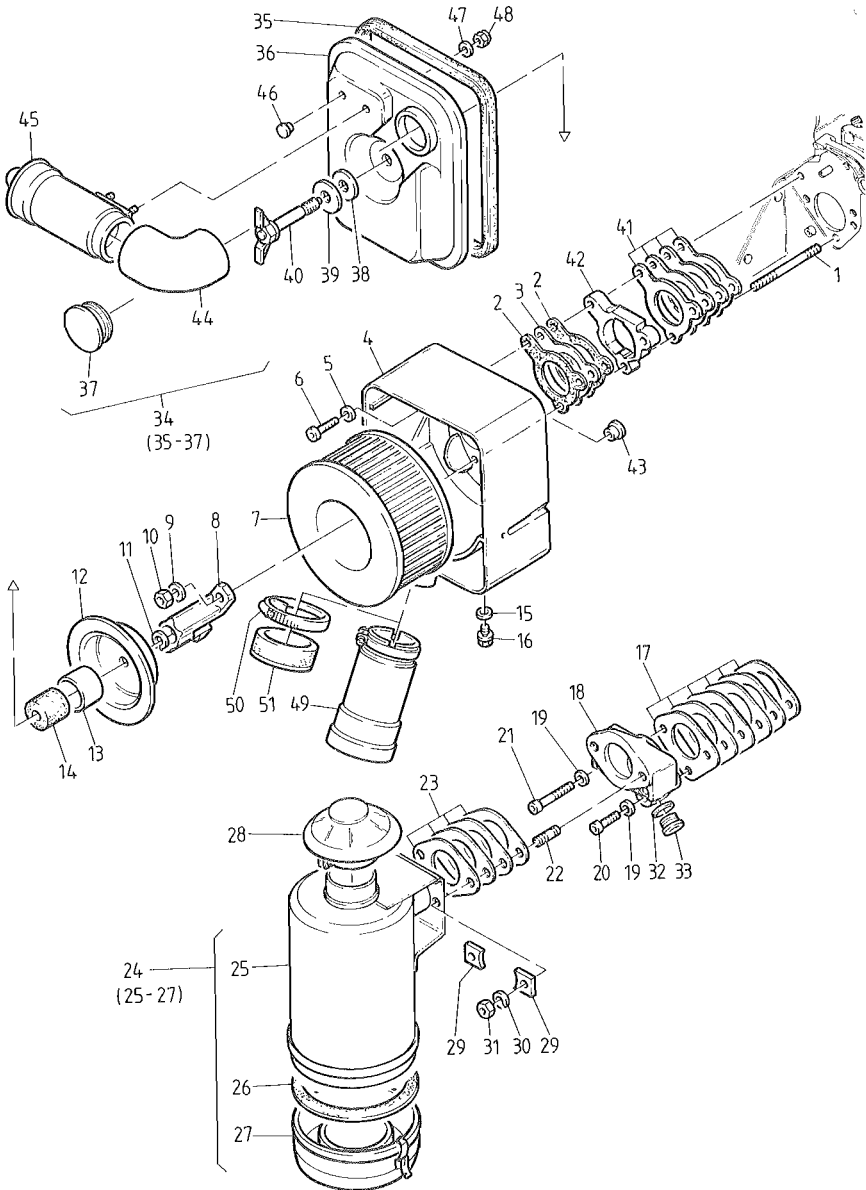

Fig.- No.	HATZ Ident-No.	Stück Qty.				P / W d / D	Bemerkungen Notes
		1D20	1D30 1D40	1D60	1D80		
1	50038900	2	2	2	2		M 8 x 60 DIN 835-8.8
2	04029800	2	2	-	-	d2	
2	04006300	-	-	2	2	d2	
3	04029701	1	1	-	-		
3	04006200	-	-	1	1		
4	04029912	1	1	-	-		
4	04004312	-	-	1	1		s.Tafel, Tabl. 29 - Pos. 45
5	50095100	1	1	1	1		A 8 DIN 137-A3C
6	50080800	1	1	-	-		M 8 x 42 DIN 912-8.8
6	50398400	-	-	1	1		M 8 x 45 DIN 6912-8.8 A3C
7	04030100	1	1	-	-	W2	
7	40084501	-	-	1	1	W2	
8	01490900	1	1	-	-		
8	01483400	-	-	1	1		
9	50148100	2	2	2	2		8,4 DIN 125 St A3C
10	50129500	2	2	2	2		M 8 DIN 985-5 A3C
11	50412000	1	1	1	1		10 x 1 DIN 471
12	05039200	1	1	-	-		
12	05036400	-	-	1	1		
13	05039300	1	1	1	1		33 x 35 x 23,5
14	03579400	1	1	1	1		
15	50000900	1	1	-	-		A 8 x 11,5 DIN 7603-Cu
15	50062400	-	-	1	1		A 10 x 13,5 DIN 7603-Cu
16	50137900	1	1	-	-		M 8 x 1 DIN 7604
16	50062300	-	-	1	1		M 10 x 1 DIN 908-5.8 A3C
17	01280201	-	-	1	1		
18	03987200	-	-	1	1		
19	50095100	-	-	3	3		A 8 DIN 137 A3C
20	50175900	-	-	1	1		M 8 x 30 DIN 912-8.8 A3C
21	50288800	-	-	2	2		M 8 x 55 DIN 912-8.8 A3C
22	50145400	-	-	2	2		M 10 x 28 DIN 835-8.8 A3C
23	01158700	-	-	1	1		

A 02
 Luftfilter
 Air filter
 Filtre à air
 Filtro de aire
 Filtro aria

Tafel Nr.
 Tabl. No.
 Tavola N.

22

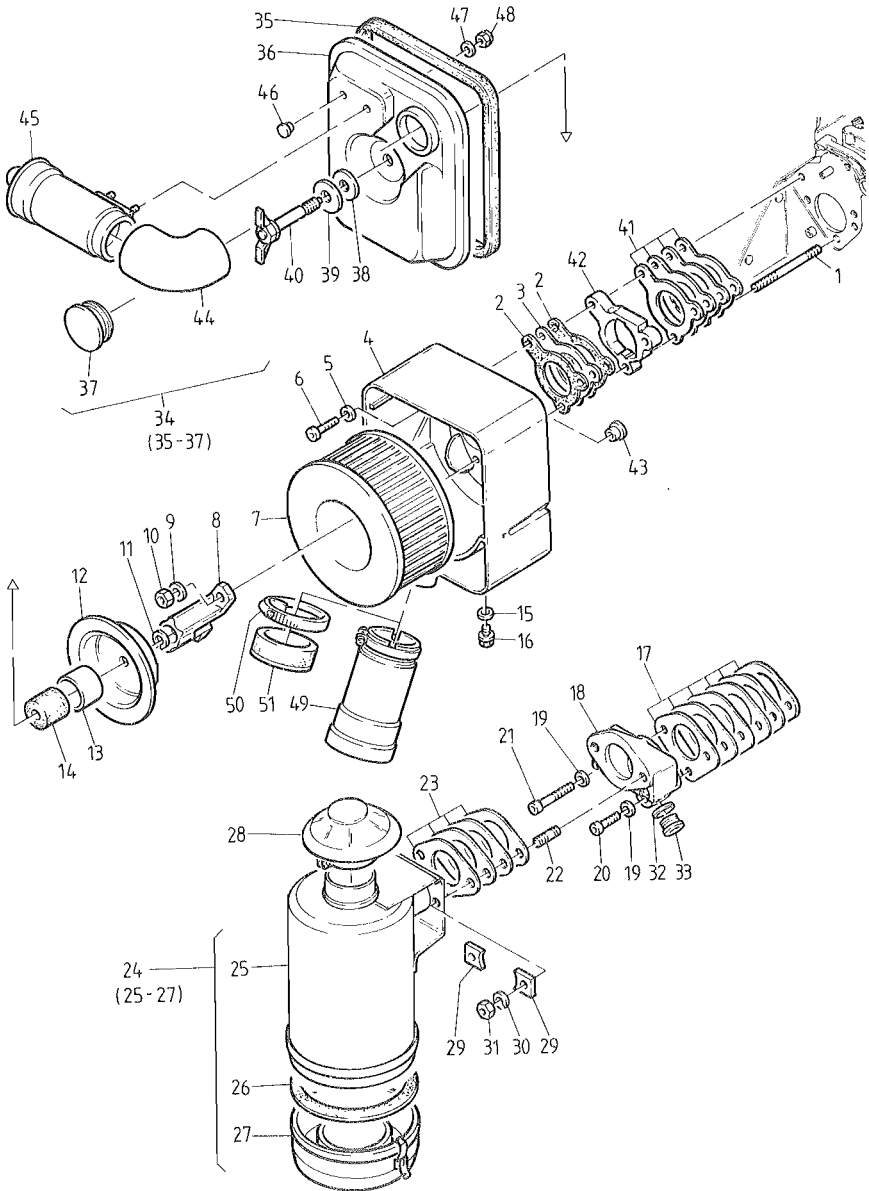

Fig.- No.	HATZ Ident-No.	Stück Qty.				P / W d / D	Bemerkungen Notes
		1D20	1D30 1D40	1D60	1D80		
24	01078500	-	-	1	1		
25	-----	-	-	-	-		
26	49038000	-	-	1	1		
27	49056600	-	-	1	1		
28	40036700	-	-	1	1		Ø 62 mm
29	03945400	-	-	2	2		
30	50135600	-	-	2	2		10 DIN 128 A3C
31	50145800	-	-	2	2		M 10 DIN 934-8 A3C
32	50001600	-	-	1	1		A 22 x 27 DIN 7603-Cu
33	50140400	-	-	1	1		M 22 x 1,5 DIN 7604 A3C
34	01496700	1	1	-	-		
34	01496800	-	-	1	1		
35	04061501	1	1	-	-		630 mm
35	04047701	-	-	1	1		705 mm
36	-----	-	-	-	-		
37	05039400	1	1	1	1		
38	03814100	1	1	1	1		
39	05038700	1	1	1	1		11 x 36 x 3
40	01490800	1	1	1	1		
41	01449100	1	1	-	-		
41	01287900	-	-	1	1		
42	04053100	1	1	-	-		
42	04047300	-	-	1	1		
43	50395700	1	1	1	1		15 PHT
44	05038901	1	1	1	1		
45	01491001	1	1	1	1		
46	50411900	2	2	2	2		F2
47	50120000	2	2	2	2		A 6,4 DIN 9021-St A3C
48	40028300	2	2	2	2		M 6 C4P SSN 440-8
49	01471200	1	1	-	-		
49	01411000	-	-	1	1		
50	50406600	1	1	1	1		40/60
51	01481400	1	1	-	-		
51	00575900	-	-	1	1		

A 02

Luftfilter – A 1D35 - 40
Air filter – A 1D35 - 40
Filtre à air – A 1D35 - 40
Filtro de aire – A 1D35 - 40
Filtro aria – A 1D35 - 40

Tafel Nr.
Tabl. No.
Tavola N.

23

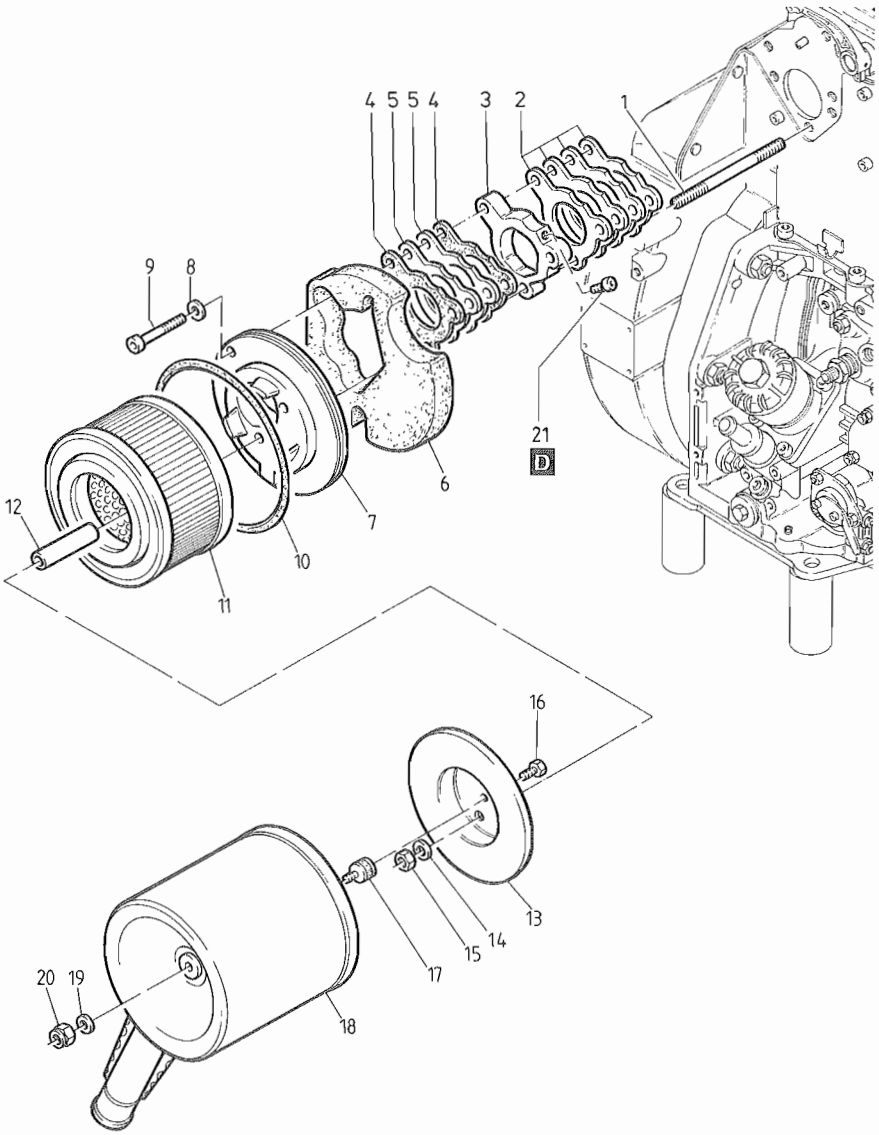

Fig.- No.	HATZ Ident-No.	Stück Qty.	P / W d / D	Bemerkungen Notes
		A1D35 A1D40		
1	50412100	2		M 8 x 125 DIN 835-5.8
2	01449100	1		
3	04053100	1		
4	04029800	3		
5	04029701	2		
6	04063201	1		
7	04054701	1		
8	50095100	1		A 8 DIN 137 A3C
9	50342400	1		M 8 x 50 DIN 6912-8.8 A3C
10	04055700	1		135 x 6
11	04030100	1	W2	
12	04039610	1		9 x 16 x 64,7
13	04054800	1		
14	50148100	2		8,4 DIN 125-St A3C
15	50129500	2		M 8 DIN 985-5 A3C
16	50333500	1		M 6 x 8 DIN 933-8.8 A3C
17	50395100	1		25 / 25
18	01281100	1		
19	50144500	1		6,4 DIN 125-St A3C
20	40028300	1		M 6 SSN 440-8 Cu
21	50112600	1		M 5 x 10 DIN 6912-8.8 A3C

Abgasdämpfer – S, Z, T, U
 Exhaust silencer – S, Z, T, U
 Silencieux – S, Z, T, U
 Silenciador – S, Z, T, U
 Marmitta – S, Z, T, U

Tafel Nr.
 Tabl. No.
 Tavola N.

A 03

24

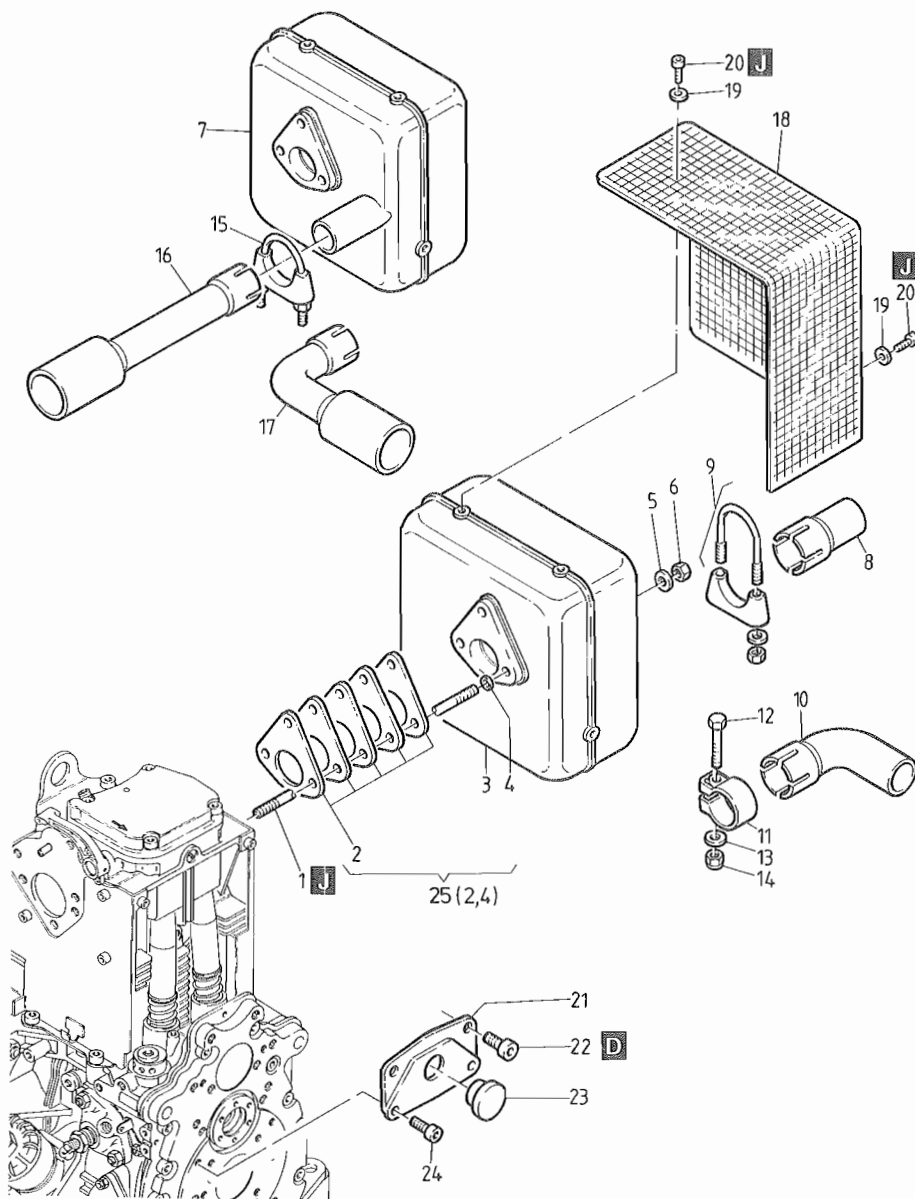

Fig.- No.	HATZ Ident-No.	Stück Qty.				P / W d / D	Bemerkungen Notes
		1D20	1D30	1D60	1D80		
			1D40				
			A1D35				
			A1D40				
1	50059100	3	3	-	-		M 8 x 120 DIN 835-8.8 A3C
1	50129400	-	-	3	3		M 8 x 140 DIN 835-8.8 A3C
2	-----	-	-	-	-		
3	01416900	1	1	-	-		
3	01448600	-	1	-	-		1D35
3	01181301	-	-	1	1		
4	05001800	3	3	3	3		8 x 10 x 1,5
5	50148100	3	3	3	3		8,4 DIN 125-St A3C
6	40028400	3	3	3	3		VM 8 DIN 980-8 C3A
7	01417801	1	1	-	-		
7	01416301	-	-	1	1		
8	03998300	1	1	-	-		
9	00873100	1	1	-	-		
10	03740800	1	1	-	-		
10	03877300	-	-	1	1		
11	03740900	1	1	-	-		41,5 mm
11	03877700	-	-	1	1		52,5 mm
12	50380000	1	1	-	-		M 8 x 50 DIN 931-8.8 A3C
12	50249500	-	-	1	1		M 10 x 50 DIN 931-8.8 A3C
13	50148100	1	1	-	-		8,4 DIN 125-St A3C
13	50145900	-	-	1	1		10,5 DIN 125-St A3C
14	40028400	1	1	-	-		VM 8 DIN 980-8 C3A
14	40028600	-	-	1	1		VM 10 DIN 980-8 C3A
15	50388000	1	1	-	-		1/8-28
15	50388100	-	-	1	1		3/8-35
16	03997300	1	1	-	-		
16	03997100	-	-	1	1		
17	03997200	1	1	-	-		
17	03997000	-	-	1	1		
18	01428500	1	1	-	-		
18	01191901	-	-	1	1		
19	05034200	8	8	10	10		6,5 x 38
20	50255700	4	4	5	5		M 6 x 12 DIN 912-8.8 C4P
21	03985300	1	1	1	1		
22	50135700	2	2	2	2		M 10 x 16 DIN 912-8.8 A3C
23	40091400	1	1	1	1		F 28
24	50165400	2	2	2	2		M 8 x16 DIN 912-8.8 A3C
25	01489300	1	1	-	-	d1	
25	01471100	-	-	1	1	d1	

A 03

Abgasdämpfer – C
Exhaust silencer – C
Silencieux – C
Silenciador – C
Marmitta – C

Tafel Nr.
Tabl. No.
Tavola N.

25

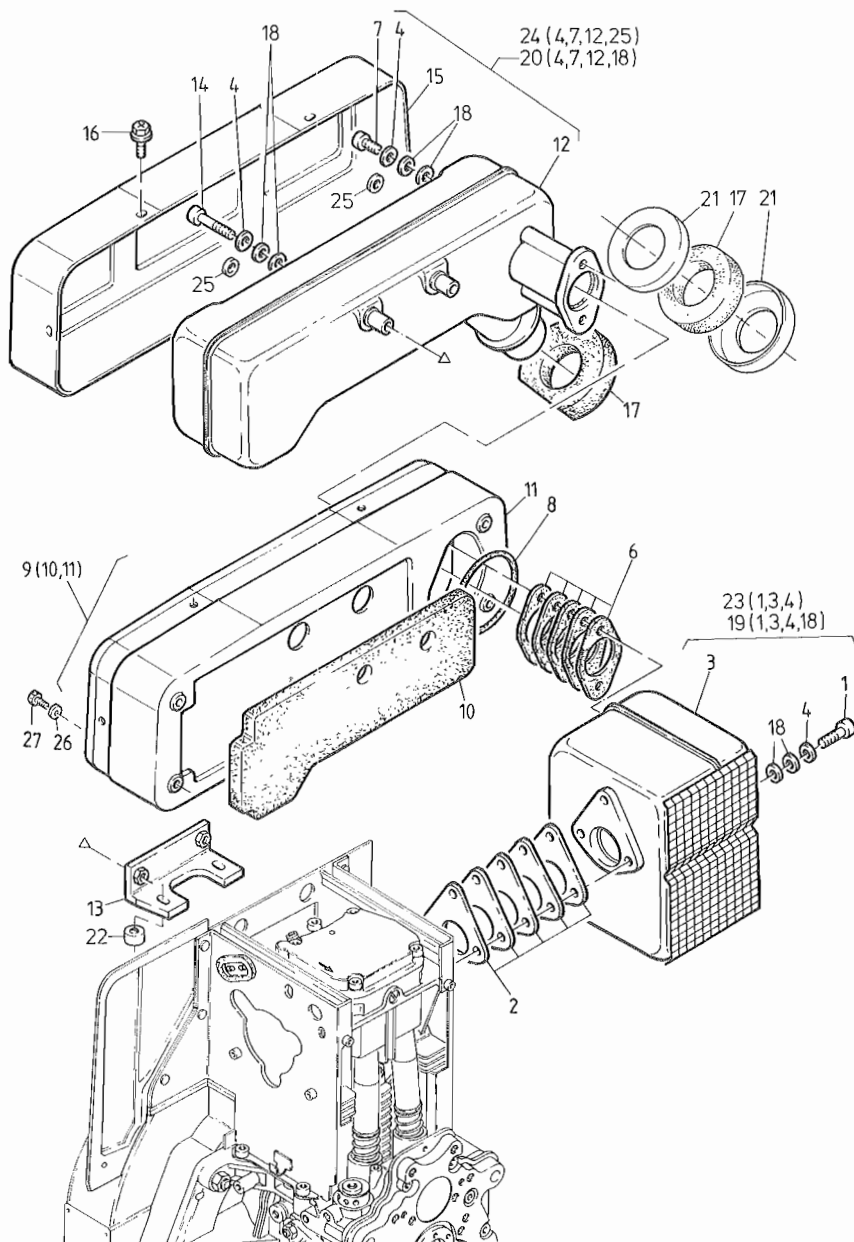

Fig.- No.	HATZ Ident-No.	Stück Qty.	P / W d / D	Bemerkungen Notes
		1D30 C	1D60 C	
		1D40 C	1D80 C	
1	50404000	3	3	M 8 x 30 DIN 912-8.8 C4P
2	01427900	1	-	
2	01429100	-	1	
3	-----	-	-	
4	50347301	7	-	VHZ 8
4	04080100	-	7	8,5 x 15,5 x 4
5	-----	-	-	
6	01309300	1	-	
6	01287800	-	1	
7	50403900	2	2	M 8 x 25 DIN 912-8.8 C4P
8	50349700	-	1	100 x 2,5
9	01309400	1	-	
9	01278200	-	1	
10	04078800	1	-	
10	04045400	-	1	
11	-----	-	-	
12	-----	-	-	
13	01307800	1	-	
13	01282710	-	1	
14	50404100	2	2	M 8 x 60 DIN 912-8.8 C4P
15	01307501	1	-	
15	01274001	-	1	
16	50289200	10	6	M 6 x 12 KZ 1
17	04079500	1	-	
17	04050000	-	1	
18	50001100	-	14	A 12 x 15,5 DIN 7603-Cu
19	01469010	-	1	
20	01469100	-	1	
21	04079400	2	-	
22	04064600	2	-	8,4 x 19 x 5,5
23	01309600	1	-	
24	01309500	1	-	
25	50115700	4	-	8,4 DIN 433-St
26	50002700	-	4	6 DIN 128
27	50025700	-	4	M 6 x 16 DIN 933-8.8

A 04

Andrehkurbel
Starting handle
Manivelle
Manivela
Manovella

Tafel Nr.
Tabl. No.
Tavola N.

26

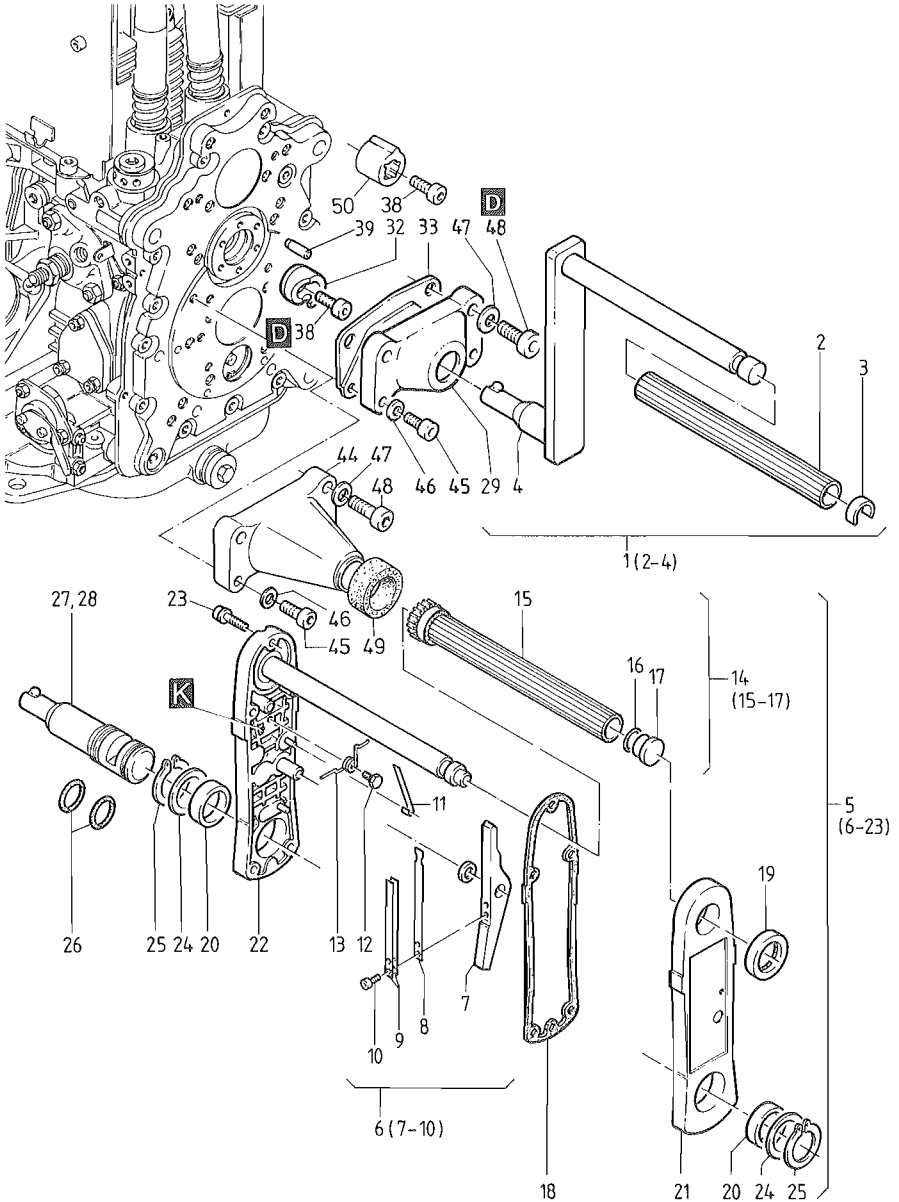

Fig.- No.	HATZ Ident-No.	Stück Qty.				P / W d / D	Bemerkungen Notes
		1D20	1D30	1D60	1D80		
			1D40				
			A1D35				
			A1D40				
1	01248002	1	1	1	1		80 mm
1	01426502	1	1	1	1		140 mm
1	01426702	1	1	1	1		160 mm
1	01407302	1	1	1	1		200 mm
1	01433202	1	1	1	1		275 mm
1	01469800	1	1	1	1		330 mm
2	03522400	1	1	1	1		
3	03515400	1	1	1	1		
4	-----	-	-	-	-		
5	01027805	1	1	1	1		„A“
6	01011404	1	1	1	1		
7	-----	-	-	-	-		
8	03812102	1	1	1	1		
9	03917100	1	1	1	1		
10	50316500	2	2	2	2		M 5 x 8 DIN 6912-8.8
11	03954900	1	1	1	1		
12	03955600	1	1	1	1		
13	03955900	1	1	1	1		„A“
14	01011310	1	1	1	1		
15	-----	-	-	-	-		
16	50169100	1	1	1	1		19 x 1,8
17	50199200	1	1	1	1		
18	03813000	1	1	1	1		
19	50194200	1	1	1	1		
20	50193400	2	2	2	2		
21	-----	-	-	-	-		
22	-----	-	-	-	-		
23	50194400	5	5	5	5		M 6 x 25 DIN 6912-8.8 A3C
24	03928600	0...4	0...4	0...4	0...4		
25	50194300	2	2	2	2		A 30 x 1,5K DIN 983
26	50258500	2	2	2	2		26 x 1,5
27	01187202	1	1	1	1		80 mm
27	01426802	1	1	1	1		140 mm
27	01426902	1	1	1	1		160 mm
27	01411402	1	1	1	1		200 mm
27	01421102	1	1	1	1		275 mm
27	01469700	1	1	1	1		330 mm
28	-----	-	-	-	-		

A 04 Andrehkurbel
 Starting handle
 Manivelle
 Manivela,
 Manovella

Tafel Nr.
 Tabl. No.
 Tavola N.
26

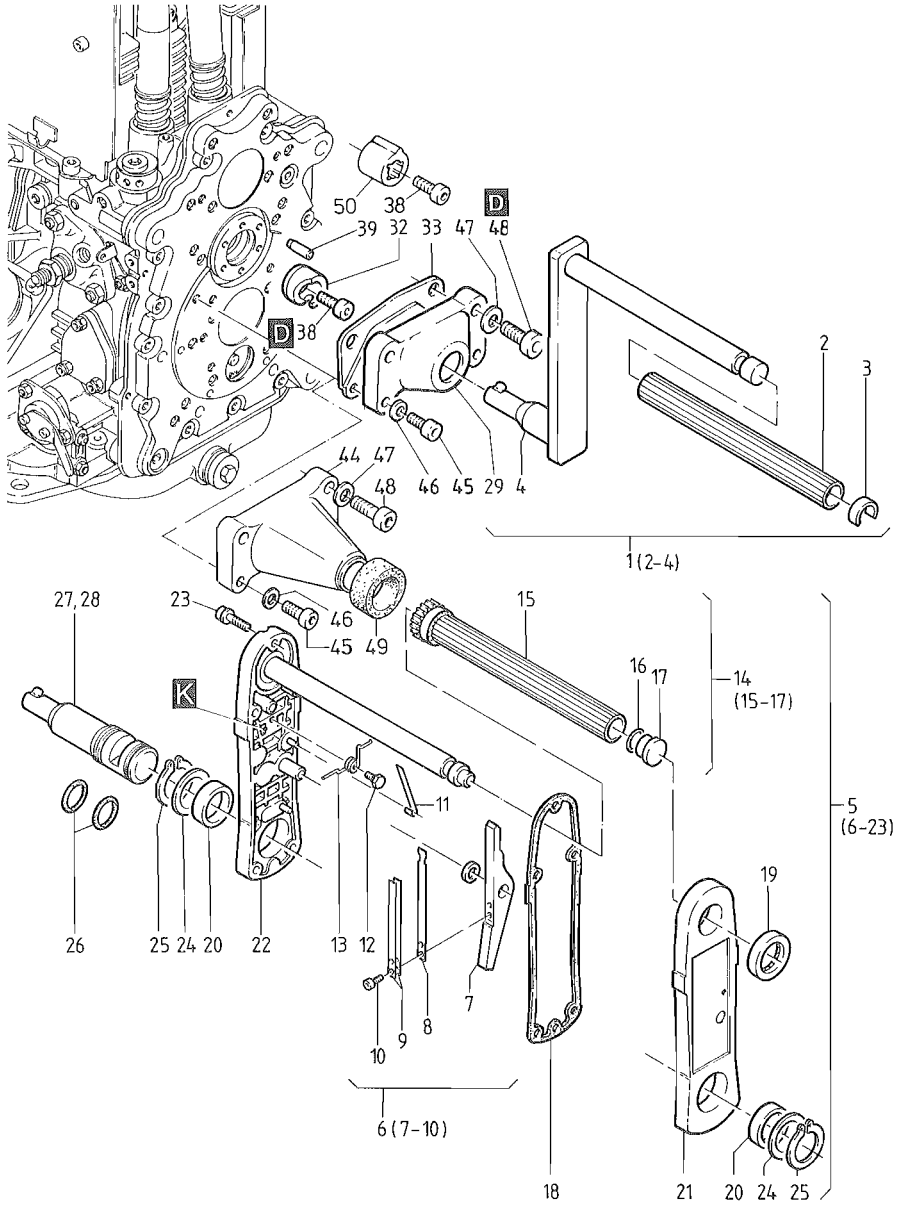

Fig.- No.	HATZ Ident-No.	Stück Qty.				P / W d / D	Bemerkungen Notes
		1D20	1D30	1D60	1D80		
			1D40				
			A1D35				
			A1D40				
29	01463600	1	1	1	1		
30	-----	-	-	-	-		
31	-----	-	-	-	-		
32	04020310	1	1	1	1		
33	03985300	1	1	1	1		
34	-----	-	-	-	-		
35	-----	-	-	-	-		
36	-----	-	-	-	-		
37	-----	-	-	-	-		
38	50134900	2	2	2	2		M 8 x 16 DIN 6912-8.8 A3C
39	50387100	1	1	1	1		5 M 6 x 20 DIN 6325
40	-----	-	-	-	-		
41	-----	-	-	-	-		
42	-----	-	-	-	-		
43	-----	-	-	-	-		
44	01459500	1	1	1	1		80 - 200 mm
44	01433300	1	1	1	1		„C“ 200 - 265 mm
45	50183000	2	2	2	2		M 8 x 35 DIN 912-8.8 A3C
46	50148100	2	2	2	2		8,4 DIN 125-St A3C
47	50145900	2	2	2	2		10,5 DIN 125-St A3C
48	50327800	2	2	2	2		M 10 x 35 DIN 912-8.8 A3C
49	03579700	1	1	1	1		„C“
50	04082900	1	1	1	1		

A 04

Reversierstarter
Recoil starter
Démarreur réversible
Arrancador reversible
Avviamento a strappo

Tafel Nr.
Tabl. No.
Tavola N.

27

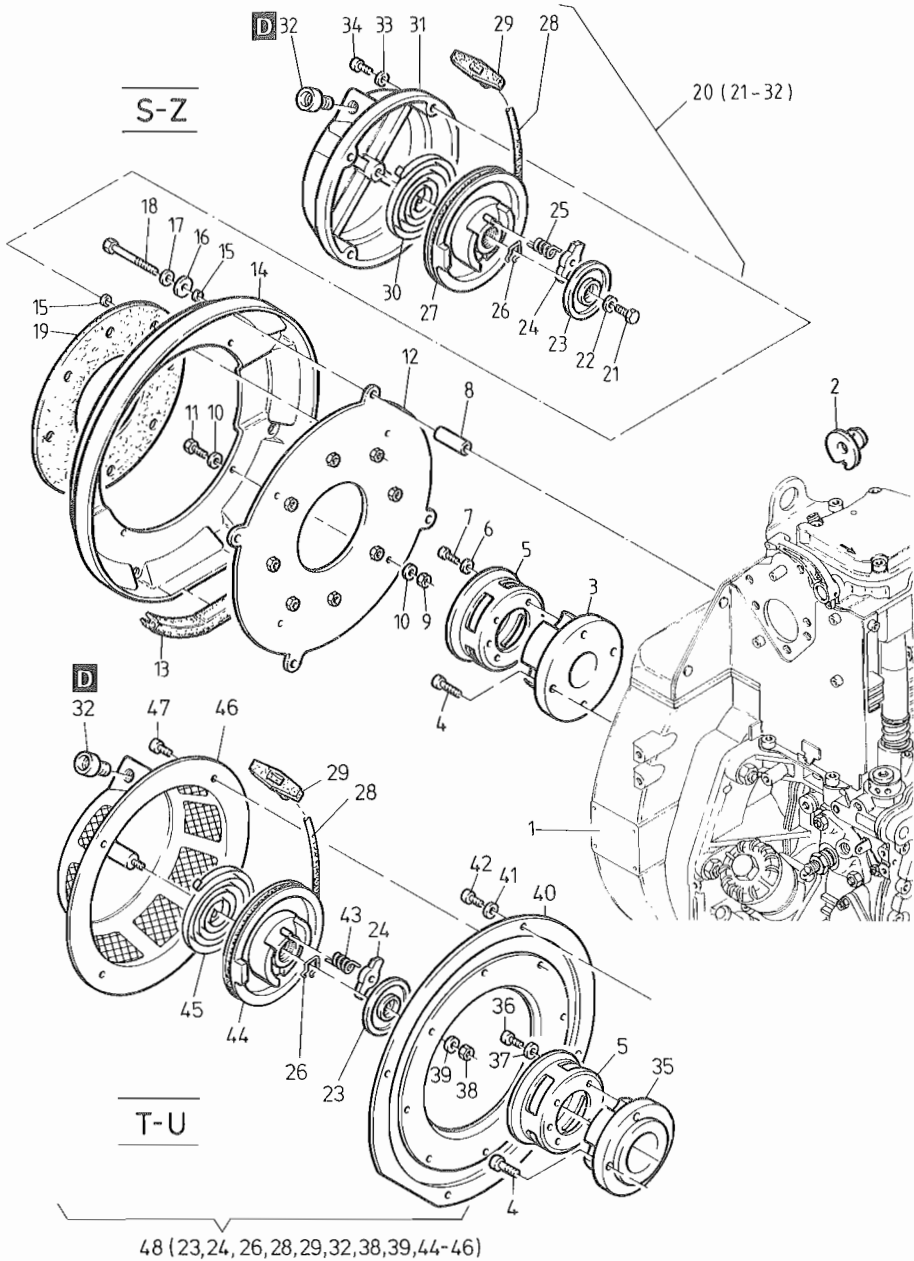

Fig.- No.	HATZ Ident-No.	Stück Qty.	P / W d / D	Bemerkungen Notes
		1D20	1D30 1D40 A1D35 A1D40	
1	-----	-	-	
2	03996200	1	1	
3	05006200	1	1	
4	50051900	1	1	M 8 x 20 DIN 912-8.8
5	05001100	1	1	
6	50170900	4	4	6 DIN 128 A3C
7	50170700	4	4	M 6 x 16 DIN 912-8.8
8	05009300	4	4	7 x 12 x 37
9	40028200	4	4	M 5
10	50216300	4	4	5,3 DIN 125-St A3C
11	50360300	4	4	M 5 x 12 DIN 933-8.8 A3C
12	01448200	1	1	
13	03990700	1	1	
14	05009000	1	1	
15	05009200	8	8	7 x 10 x 2,5
16	50114300	4	4	6,4 DIN 7349 Zn
17	50170900	4	4	6
18	50383700	4	4	M 6 x 55 DIN 931-8.8 A3C
19	05009100	1	1	
20	01444300	1	1	„S-Z“
21	50146300	1	1	M 6 x 18 DIN 933-8.8 A3C
22	50165600	1	1	6,5 x 14 DIN 6904 A3C
23	50348300	1	1	
24	50347900	1	1	
25	03996300	1	1	
26	50348100	1	1	
27	01434700	1	1	
28	50348400	1	1	
29	50348500	1	1	
30	50348000	1	1	
31	03944602	1	1	
32	03946800	1	1	

A 04

Reversierstarter
Recoil starter
Démarrreur reversible
Arrancador reversible
Avviamento a strappo

Tafel Nr.
Tabl. No.
Tavola N.

27

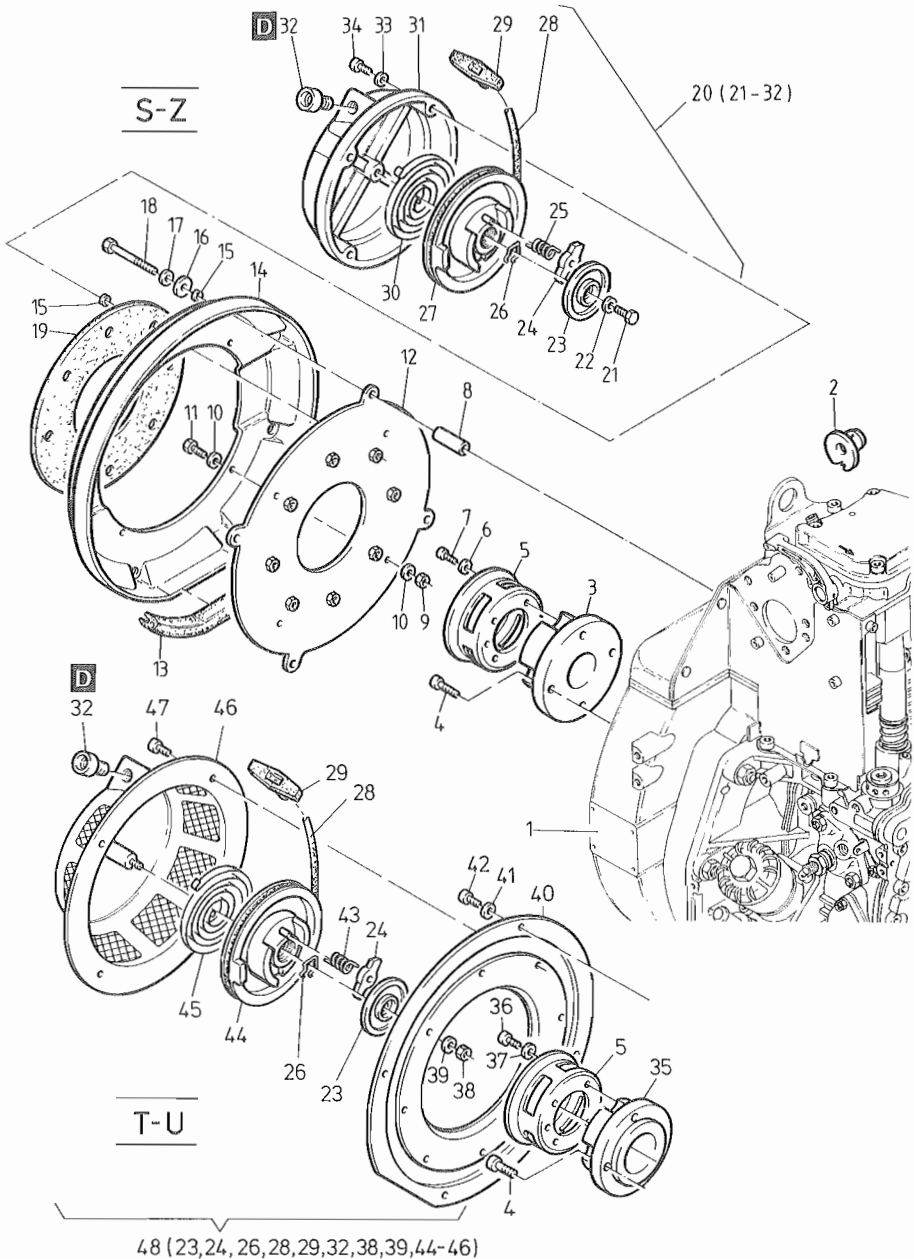

Fig.- No.	HATZ Ident-No.	Stück Qty.	P / W d / D	Bemerkungen Notes
		1D20	1D30 1D40 A1D35 A1D40	
33	50081200	4	4	A6 DIN 137
34	50170700	4	4	M 6 x 16 DIN 912-8.8 A3C
35	05001000	1	1	
36	50170700	4	4	M 6 x 16 DIN 912-8.8
37	50170900	4	4	6 DIN 128 A3C
38	50144400	1	1	M6 DIN 934-8 A3C
39	50165600	1	1	6,5 x 14 DIN 6904 A3C
40	01439800	1	1	„T-U“
41	50144500	4	4	6,4 DIN 128-St A3C
42	50165500	4	4	M 6 x 12 DIN 933-8.8 A3C
43	50348200	1	1	
44	50347800	1	1	
45	50348000	1	1	
46	-----	-	-	
47	50289200	4	4	M 6 x 12 A3C
48	01434600	1	1	„T-U“

Starter, Generator
 Starter, alternator
A 05 Demarreur, alternateur
 Arrancador, alternador
 Motorino avviamento, alternatore

Tafel Nr.
 Tabl. No.
 Tavola N.

28

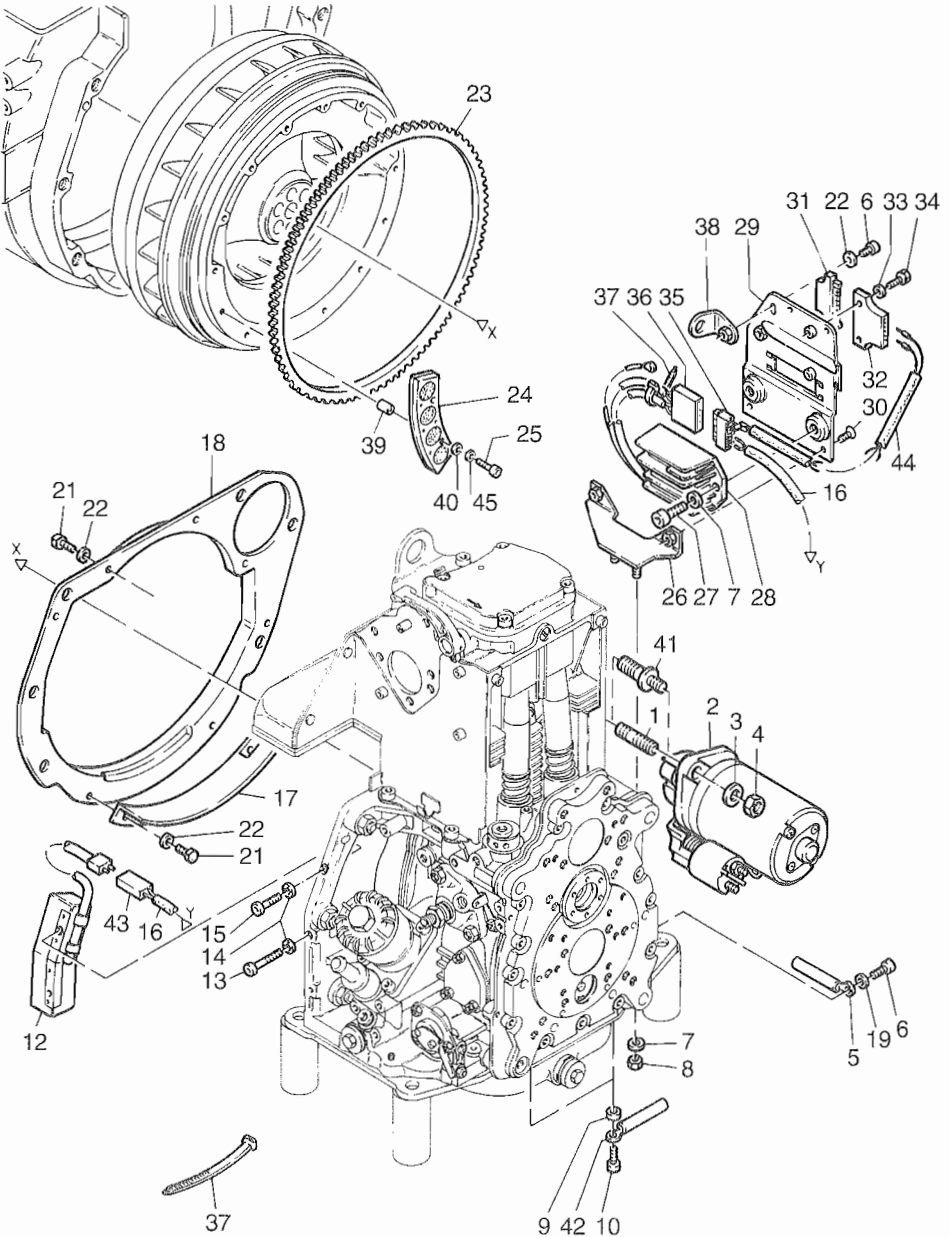

Fig.- No.	HATZ Ident-No.	Stück Qty.	P / W d / D	Bemerkungen Notes
		1D20 - 40 A1D35 - 40	1D60 1D80	
1	50201200	2	2	M 12 x 50 DIN 835-8.8 A3C f. Tafel, Tab. 32 - Pos. 9
1	50365000	2	2	M 12 x 50 DIN 938-8.8 A3C f. Tafel, Tab. 13 - Pos. 19
2	50353510	1	-	12 V - 1,6 kW „S, Z, C“
2	50353420	-	1	12 V - 1,5 kW „S, Z, C“
2	50382201	1	-	24 V - 1,6 kW „S, Z, C“
2	50385311	-	1	24 V „S, Z, C“
2	50389700	1	-	12 V - 1,6 kW „T - U“
2	50385000	-	1	12 V „T - U“
3	50093700	2	2	13 DIN 125-St A3C
4	50380600	2	2	M 12 DIN 970 A3C
5	01459700	2	2	
6	50149100	2	2	M 6 x 12 DIN 912-8.8 A3C
7	50208500	4	4	8 DIN 128 A3C
8	50148000	2	2	M 8 DIN 934-8 A3C
9	04021000	2	2	6,3 x 12 x 15,5
10	50170700	2	2	M 6 x 16 DIN 912-8.8 A3C
11	-----	-	-	
12	01440700	1	-	12 V
12	01439000	-	1	12 V
12	01440800	1	-	24 V
12	01439100	-	1	24 V
13	50236600	1	-	M 6 x 25 DIN 6912-8.8 A3C
13	50401200	-	1	M 6 x 35 DIN 6912-8.8 A3C
14	50165600	2	2	6,5 x 14 DIN 6904 - A3C
15	50170600	1	-	M 6 x 20 DIN 912-8.8 A3C
15	50236600	-	1	M 6 x 25 DIN 6912-8.8 A3C
16	01462800	1	1	
17	04021100	-	1	
18	04031810	1	-	s. Tafel, tab. 32 - Pos. 9
18	04009920	-	1	
19	50144500	1	1	
21	50165500	5	5	M 6 x 12 DIN 933-8.8 A3C
22	50170900	6	6	6 DIN 129 A 3 C
23	04032310	1	-	„S, Z, C“
23	04021210	-	1	„S, Z, C“

A 05 Starter, Generator
 Starter, alternator
 Demarreur, alternateur
 Arrancador, alternador
 Motorino avviamento, alternatore

Tafel Nr.
 Tabl. No.
 Tavola N.
28

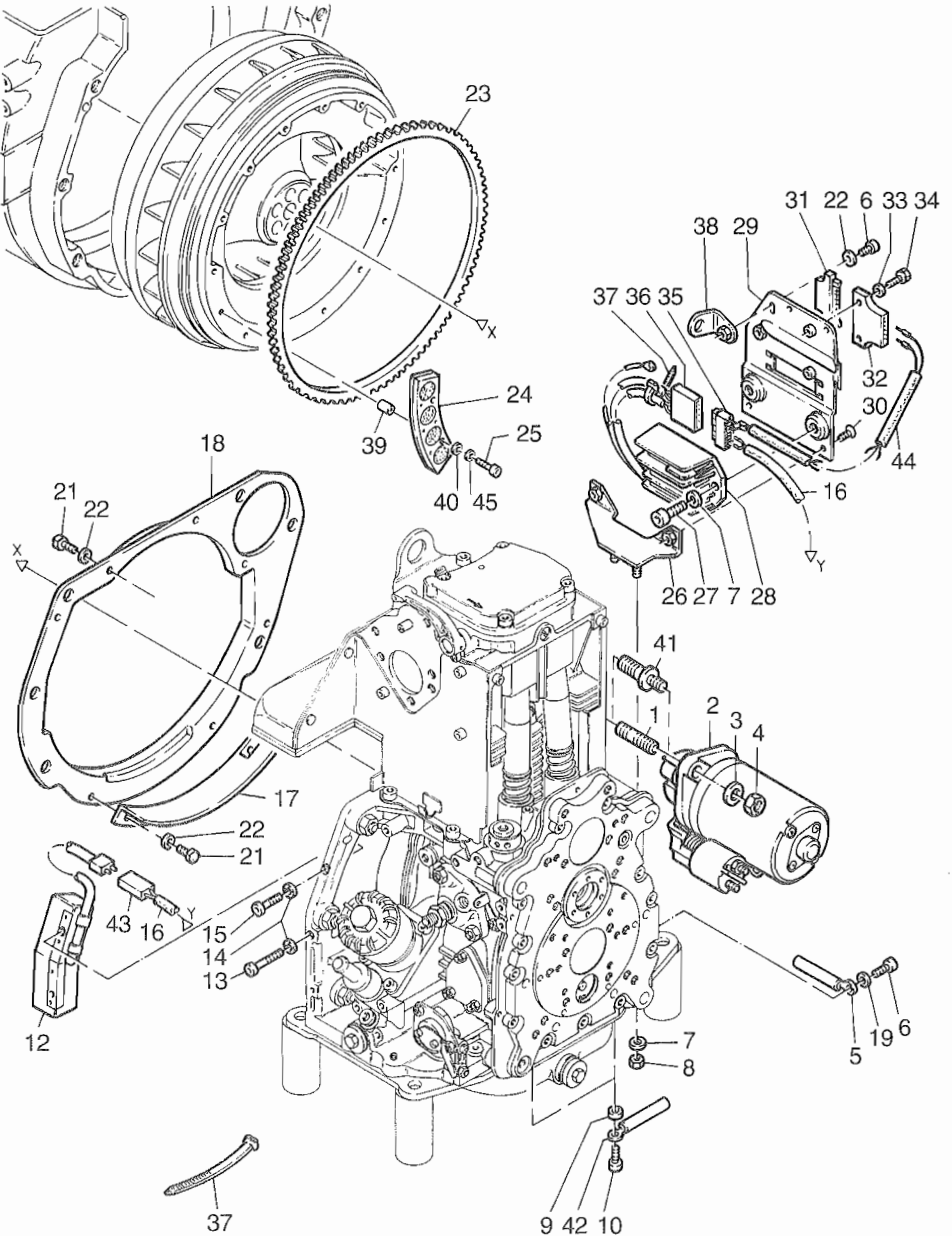

Fig.- No.	HATZ Ident-No.	Stück Qty.	P / W d / D	Bemerkungen Notes
		1D20-40	1D60	
		A1D35-40	1D80	
23	03997500	1	-	„T - U“
23	03994200	-	1	„T - U“
24	04031600	6	-	
24	04020421	-	7	
25	50327300	12	-	M 4 x 20 DIN 912-8.8
25	50397100	-	14	M 4 x 10 DIN 912-8.8-Tuf.
26	01440400	1	-	
26	01440300	-	1	
27	50165400	2	2	M 8 x 16 DIN 912-8.8 A3C
28	01248120	1	1	12 V
28	01425020	1	1	24 V
29	01440100	1	1	
30	50380800	2	2	M 6 x 10 DIN 7991-8.8 A3C
31	50373700	1	1	
32	50373600	1	1	
33	50216300	2	2	5,3 DIN 125-St A3C
34	50335700	2	2	M 5 x 25 DIN 933-8.8 A3C
35	50402100	1	1	
36	50402000	1	1	
37	50358400	4	4	
38	01440500	1	-	
38	01440200	-	1	
39	50327400	12	-	5 x 10 DIN 7346
40	50147200	12	-	4,3 DIN 125-St A3C
41	04054200	2	-	
42	01470200	2	2	
43	50379700	1	1	
44	01439400	1	1	Pos. 35 incl.
45	50002600	-	12	5 DIN 128 A3C

A 05

Armaturenkasten
Instrument box
Boitiere de bord
Cuadro de mando
Cruscotto

Tafel Nr.
Tabl. No.
Tavola N.

29

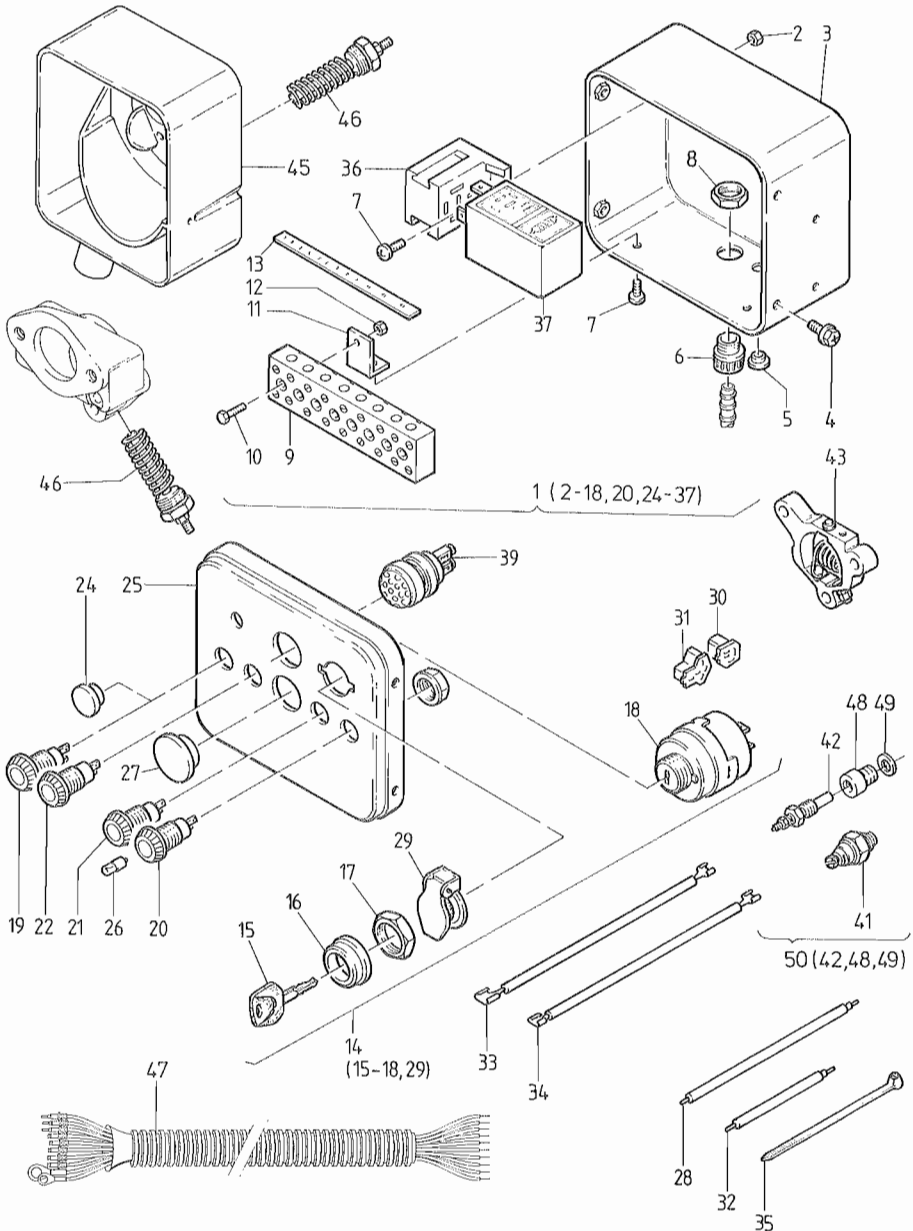

Fig.- No.	HATZ Ident-No.	Stück Qty.				P / W d / D	Bemerkungen Notes
		1D20	1D30 1D40 A1D35 A1D40	1D60	1D80		
1	01407000	1	1	1	1		12 V
1	01457700	1	1	1	1		24 V
2	40028200	1	1	1	1		
3	00716311	1	1	1	1		
4	50289200	4	4	4	4		M 6 x 12 KZ1 8.8 A3D
5	50160800	1	1	1	1		
6	50159010	1	1	1	1		
7	50049300	3	3	3	3		M 5 x 10 DIN 7985-4.8 A3R
8	50159100	1	1	1	1		
9	50160700	1	1	1	1		
10	50158800	2	2	2	2		M 4 x 20 DIN 84-4.8 A3C
11	03666700	2	2	2	2		
12	50147100	2	2	2	2		M 4 DIN 934-8 A3C
13	05004300	1	1	1	1		
14	50276502	1	1	1	1		
15	50345300	1	1	1	1	P1	
16	-----	-	-	-	-		
17	-----	-	-	-	-		
18	-----	-	-	-	-		
19	-----	-	-	-	-		
20	50176501	1	1	1	1		BATT.
21	50176600	1	1	1	1		OIL
22	50176400	1	1	1	1		TEMP.
23	-----	-	-	-	-		
24	40096000	0..3	0..3	0..3	0..3		F 17
25	03509211	1	1	1	1		
26	40009700	0..4	0..4	0..4	0..4		12 V - 2 W
26	40009800	0..4	0..4	0..4	0..4		24 V - 2W
27	40091400	0..2	0..2	0..2	0..2		F 24
28	01150101	1	1	1	1		
29	49050900	1	1	1	1		
30	50276600	1	1	1	1		4-P
31	50276700	1	1	1	1		6-P
32	01090201	2	2	2	2		
33	01089801	1	1	1	1		
34	01089901	1	1	1	1		
35	50358400	1	1	1	1		

A 05

Armaturenkasten
Instrument box
Boitiere de bord
Cuadro de mando
Cruscotto

Tafel Nr.
Tabl. No.
Tavola N.

29

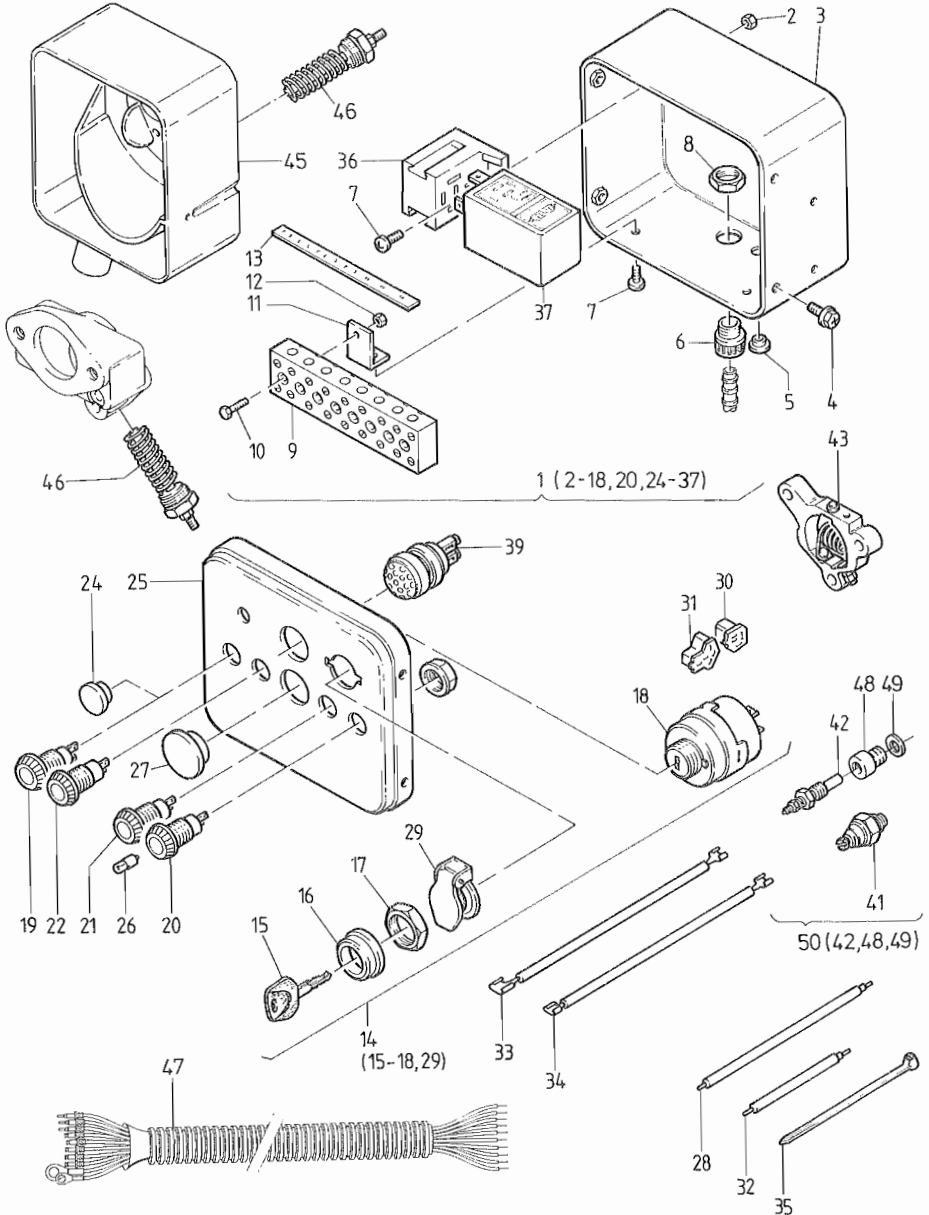

Fig.- No.	HATZ Ident-No.	Stück Qty.				P / W d / D	Bemerkungen Notes
		1D20	1D30	1D60	1D80		
			1D40				
			A1D35				
			A1D40				
36	50276000	1	1	1	1		
37	50275801	1	1	1	1		12 V HATZ MSR
37	50275901	1	1	1	1		24 V HATZ MSR
38	-----	-	-	-	-		
39	50403600	1	1	-	-		12 - 24 V
39	50397200	-	-	1	1		12 - 24 V
40	-----	-	-	-	-		
41	50272200	1	1	1	1		OIL
42	40032801	1	1	1	-		TEMP. 180 °C ± 5
42	50268600	-	-	-	1		TEMP. 220 °C ± 10
42	50344500	1	1	1	-		TEMP. „C“ 230 °C ± 10
43	01468200	1	1	-	-		12 - 24 V
43	01275500	-	-	1	1		24 V
44	-----	-	-	-	-		
45	05035100	1	1	-	-		24 V
45	04056101	-	-	1	1		24 V
46	50403700	1	1	-	-		24 V Widerstand, resistor
46	50397300	-	-	1	1		24 V Widerstand, resistor
47	01192700	1	1	1	1		„S, Z, T, U“ 2 m
47	01433600	1	1	1	1		„C“ 2 m
48	05027800	-	-	-	1		1D80C
49	50001000	-	-	-	1		A 10 x 16 DIN 7603-Cu
50	01475200	-	-	-	1		1D80C

A 06

Motorfüße
Engine brackets
Pieds moteur
Soportes del mot.
Staffe supporto motore

Tafel Nr.
Tabl. No.
Tavola N.

30

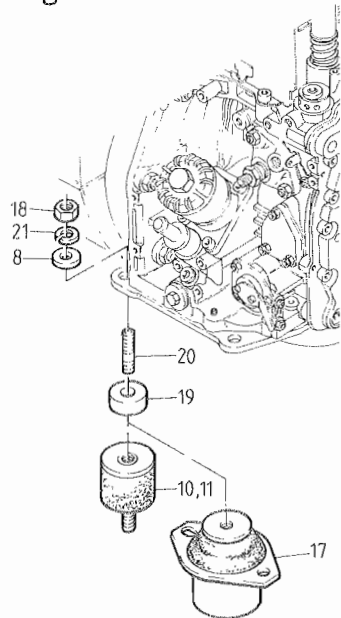
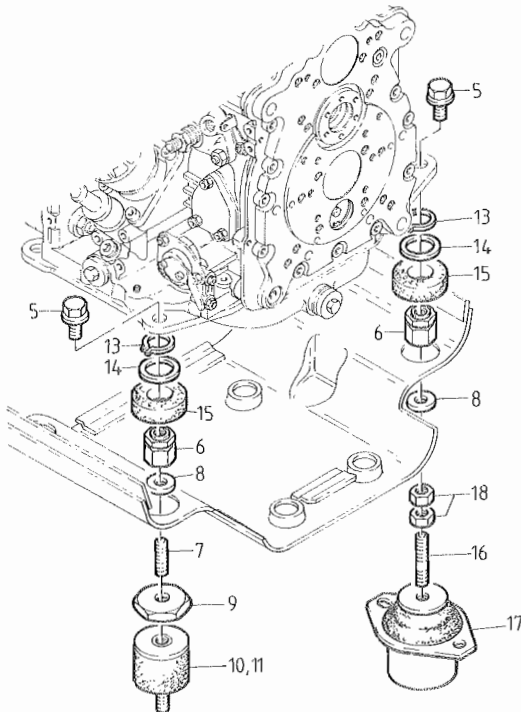
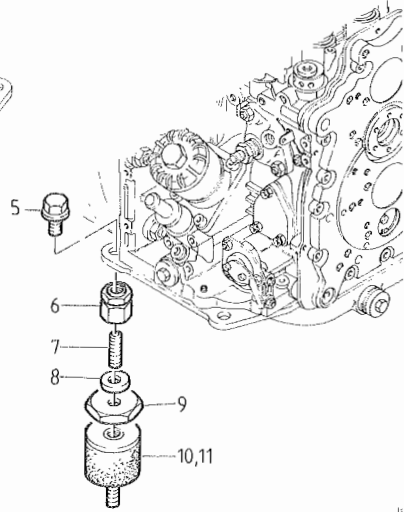
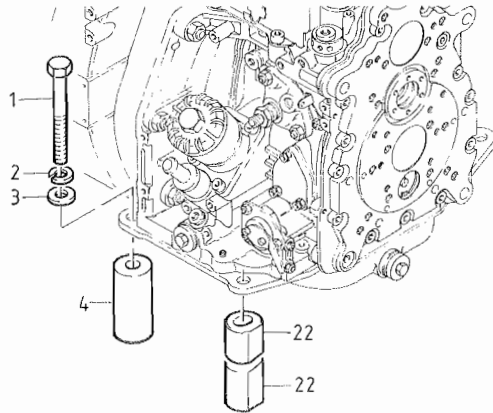

Fig.- No.	HATZ Ident-No.	Stück Qty.				P / W d / D	Bemerkungen Notes
		1D20	1D30 1D40	1D60	1D80		
1	-----	4	4	4	4	M 10 x	DIN 933-
2	50002900	4	4	4	4	10	DIN 128 A3C
3	50070600	4	4	4	4	10,5 x 25 x 4	DIN 7349 A3C
4	03995400	3	3	3	3	13 x 36 x 13	
4	05000800	3	3	-	-	13 x 36 x 45	
4	03964600	-	-	3	3	13 x 36 x 77	
5	50386600	4	4	4	4	M 10 x 20	A3C
6	03993700	4	4	4	4	M 10 x 27,5	
7	03993500	4	4	4	4	M 10 x 30	
8	50070600	4	4	4	4	10,5 x 25 x 4	DIN 7349 A3C
9	03993400	4	4	4	4	10,5 x 55 x 5	
10	50386700	4	4	4	4	40 Shore	
11	50386800	4	4	4	4	55 Shore	
12	-----	-	-	-	-		
13	50020400	4	4	4	4	A 24 x 1,2	DIN 471
14	03592301	4	4	4	4	26,1 x 38 x 1	
15	03755300	4	4	4	4		
16	03993602	4	4	4	4	M 10 x 58	
17	50323600	4	4	4	4	V 12 / 600	
18	50145800	4	4	8	8	M 10	DIN 934 A3C
19	03995400	4	4	4	4		
20	50124800	4	4	4	4	M 10 x 40	DIN 939
21	50135600	4	4	4	4	10	DIN 127
22	05020300	2	2	2	2	f. Höhe 13, f. height 13	
22	05018100	2	2	-	-	f. Höhe 45, f. height 45	
22	05018000	-	-	2	2	f. Höhe 77, f. height 77	

A 09 Abstellvorrichtung
 Stop device
 Dispositiv d'arret
 Dispos. desconectad
 Leva stopi

A 11 Hubmagnet
 Lifting magnet
 Electro aimont
 Elevador magn.
 Magnete stop

Tafel Nr.
 Tabl. No.
 Tavola N.

31

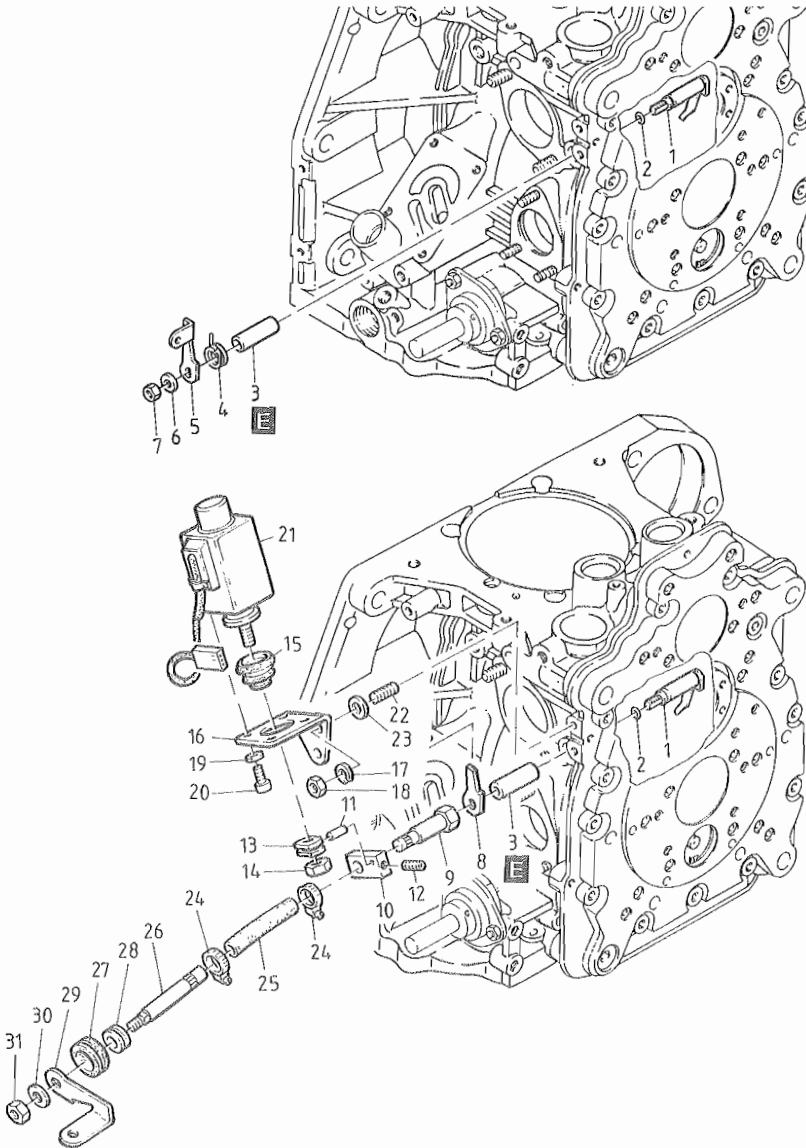

Fig.- No.	HATZ Ident-No.	Stück Qty.				P / W d / D	Bemerkungen Notes
		1D20	1D30	1D60	1D80		
			1D40				
			A1D35				
			A1D40				
1	01254601	1	1	1	1		
2	50343300	1	1	1	1		4,6 x 1,85
3	04021400	1	1	1	1		
4	04021800	1	1	1	1		
5	04021700	1	1	1	1		
6	50144500	1	1	1	1	6,4	DIN 125-St A3C
7	50328300	1	1	1	1	VM 6	DIN 980-8 A3C
8	05015100	1	1	1	1		
9	03996701	1	1	1	1		
10	05008001	1	1	1	1		
11	50125500	1	1	1	1	3 x 12	DIN 1481
12	50262400	1	1	1	1	M 6 x 10	DIN 916
13	05000900	1	1	1	1		
14	50144400	1	1	1	1	M 6	DIN 934-8 A3C
15	50248900	1	1	1	1		
16	05023500	1	1	1	1		
17	50170900	2	2	2	2	6	DIN 128 A3C
18	50144400	2	2	2	2	M 6	DIN 934-8 A3C
19	50216300	3	3	3	3	5,3	DIN 125-St A3C
20	50112600	4	4	4	4	M 5 x 10	DIN 6912-8.8 A3C
21	01446810	1	1	1	1	12 V	
21	01446910	1	1	1	1	24 V	
22	50366800	2	2	2	2	M 6 x 12	DIN 835-8.8 A 3C
23	50144500	2	2	2	2	6,4	DIN 125 A3C
24	40037300	2	2	2	2	7,5 SKZ	„C“
25	03999001	1	1	1	1	7 x 70	„C“
26	03996600	1	1	1	1		„C“
27	03565400	1	1	1	1		„C“
28	01434500	1	1	1	1		„C“
29	04021700	1	1	1	1		
30	50144500	1	1	1	1	6,4	DIN 125-St A3C
31	50328300	1	1	1	1	VM 6	DIN 980-8 A3C

A 15

Anschlußgehäuse
Intern. housing
Bride raccord
Caja de con.
Flange accoppiamento

Tafel Nr.
Tabl. No.
Tavola N.

32

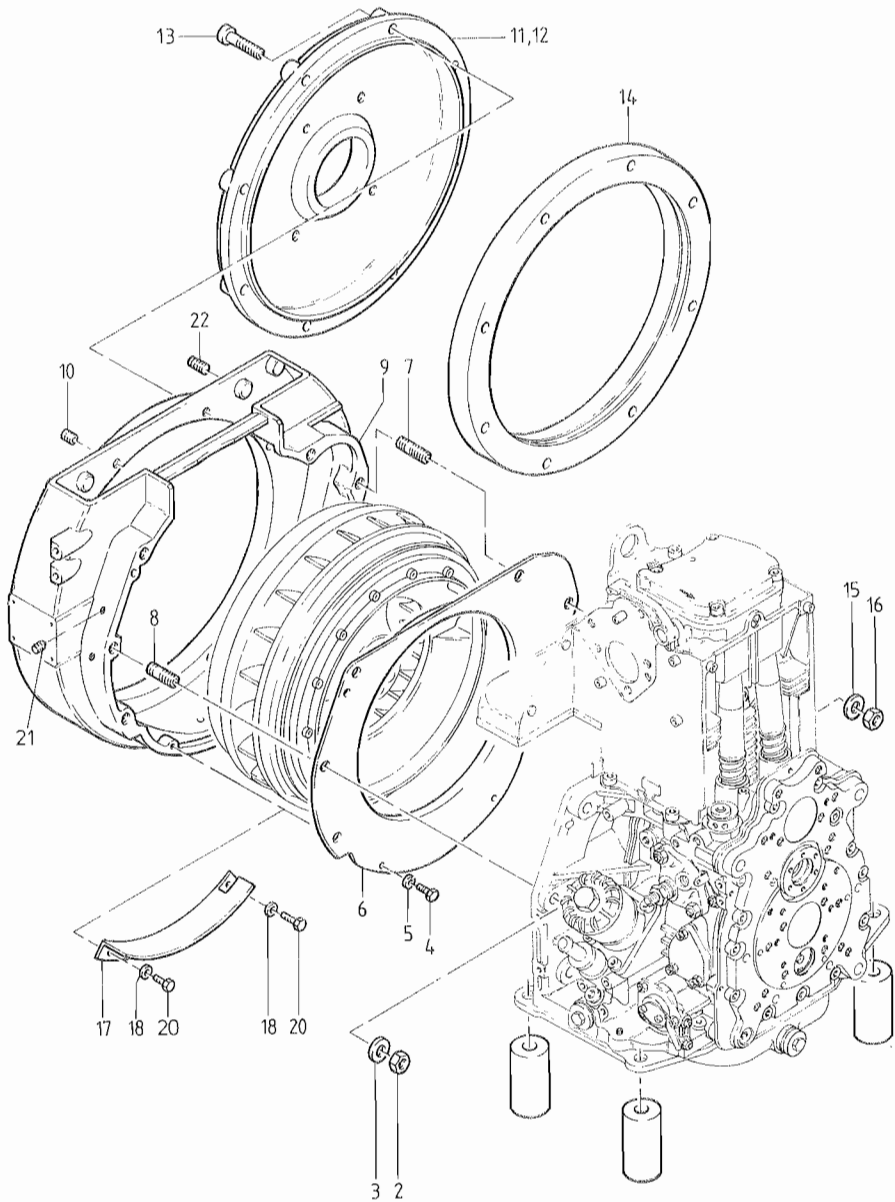

Fig.- No.	HATZ Ident-No.	Stück Qty.				P / W d / D	Bemerkungen Notes
		1D20	1D30	1D60	1D80		
			1D40				
			A1D35				
			A1D40				
1	-----	-	-	-	-		
2	50145800	4	4	-	-	M 10	DIN 934-8
2	50093600	-	-	4	4	M 12	DIN 934-8 A3C
3	50145900	4	4	-	-	10,5	DIN 125-St A3C
3	50093700	-	-	4	4	13	DIN 125-St A3C
4	50177100	2	2	2	2	M 6 X 16	DIN 933-8.8 A3C
5	50170900	2	2	2	2	6	DIN 128 A3C
6	04031100	1	1	-	-		
6	04008500	-	-	1	1		s. Taf., Tabl. 28 - Pos. 18
7	50364800	2	2	2	2	M 12 X 40	DIN 835-8.8 A3C
8	50040900	4	4	-	-	M 10 X 35	DIN 835-8.8
8	50331400	-	-	4	4	M 12 X 35	DIN 835-8.8 A3C
9	04032612	1	1	-	-	SAE 6	
9	04008211	-	-	1	1	SAE 5	
10	50065000	8	8	8	8	AM 10 X 10	DIN 913 TU. FLEK
11	03976100	1	1	-	-	SAE „B“	Ø 146,1
11	03953401	-	-	1	1	SAE „B“	Ø 146,1
12	03953501	-	-	1	1	SAE „B“	Ø 177,8
13	50055200	8	8	-	-	M 10 X 60	DIN 912-8.8
13	50054700	-	-	8	8	M 10 X 45	DIN 912-8.8
14	03954400	-	-	1	1	SAE 5	
15	50093700	2	2	2	2	13	DIN 125-St A3C
16	50093600	2	2	2	2	M 12	DIN 934-8 A3C
17	04021100	-	-	1	1	T-U	
18	50144500	-	-	2	2	6,4	DIN 125-St A3C
19	-----	-	-	-	-		
20	50177100	-	-	2	2	M 6 X 16	DIN 933-8.8 A3C
21	50395600	2	2	2	2	M 12 x 1,5	DIN 906 A3C
22	50226000	2	2	4	4	M 8 x 6	DIN 913 TU. FLEK

A 16

Wellenstummel, elast. Kupplung
Stubshaft, flexible coupling
Bout de arbre, acouplement elastic
Eje, acoplamiento elastico
Contralbero, giunto elastico

Tafel Nr.
Tabl. No.
Tavola N.

33

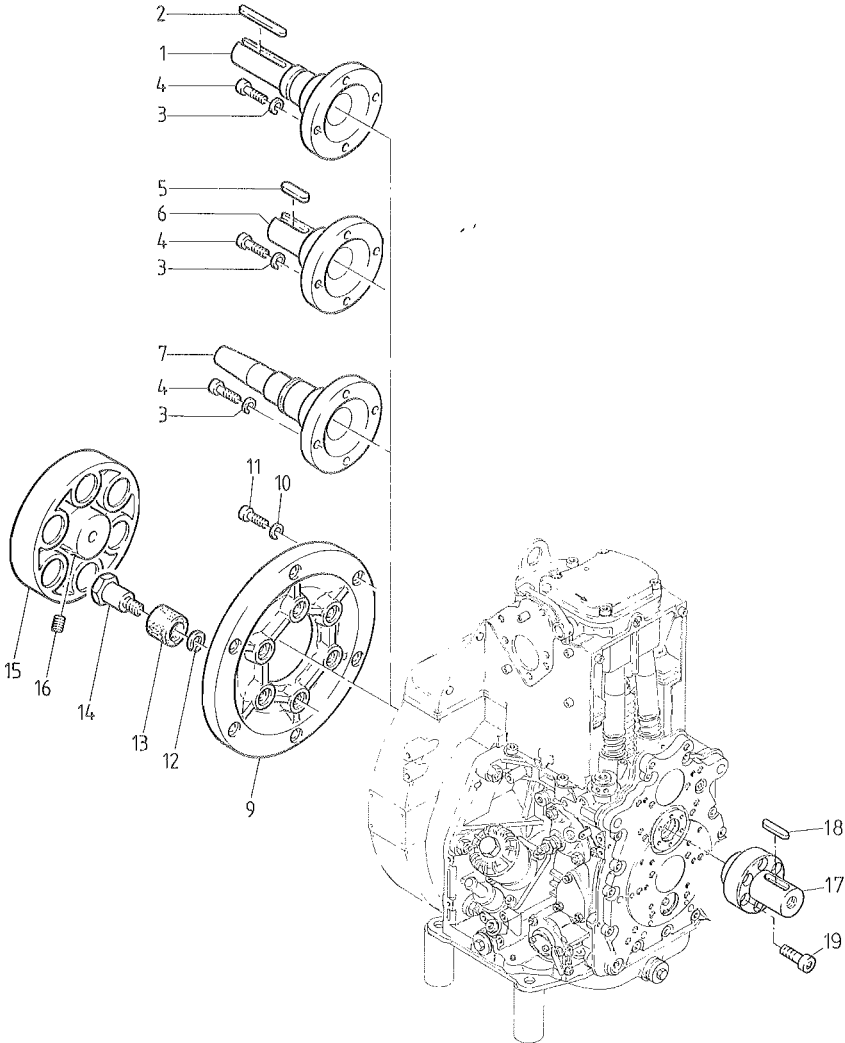

Fig.- No.	HATZ Ident-No.	Stück Qty.				P / W d / D	Bemerkungen Notes
		1D20	1D30	1D60	1D80		
			1D40				
			A1D35				
			A1D40				
1	03952000	1	1	1	1		2 - Ø 1"
2	03962700	1	1	1	1		A 6,35 x 63
3	50002800	4	4	4	4		8 DIN 128
4	50052100	4	4	4	4		M 8 x 25 DIN 912-8.8
5	50011500	1	1	1	1		A 8 x 7 x 35 DIN 6885
6	03954300	1	1	1	1		2 Ø 30 mm
7	03953200	1	1	1	1		4 (1")
9	03951700	1	1	1	1		
10	50002800	6	6	6	6		8 DIN 128
11	50051900	6	6	6	6		M 8 x 20 DIN 912-8.8
12	50061600	6	6	6	6		12 DIN 7980
13	03151000	6	6	6	6		
14	03046900	6	6	6	6		
15	03004602	1	1	1	1		
16	50004600	1	1	1	1		A M 8 x 16 DIN 916-45H
17	05007400	1	1	1	1		25
18	50011500	1	1	1	1		A 8 x 7 x 35 DIN 6885
19	50170700	6	6	6	6		M 6 x 16 DIN 912-8.8 A3C

Kupplung dauerausrückbar
Clutch perm. disconn.
Embrayage debr. continu.
Embrague permanente
Frizione

A 17

Tafel Nr.
Tabl. No.
Tavola N.

34

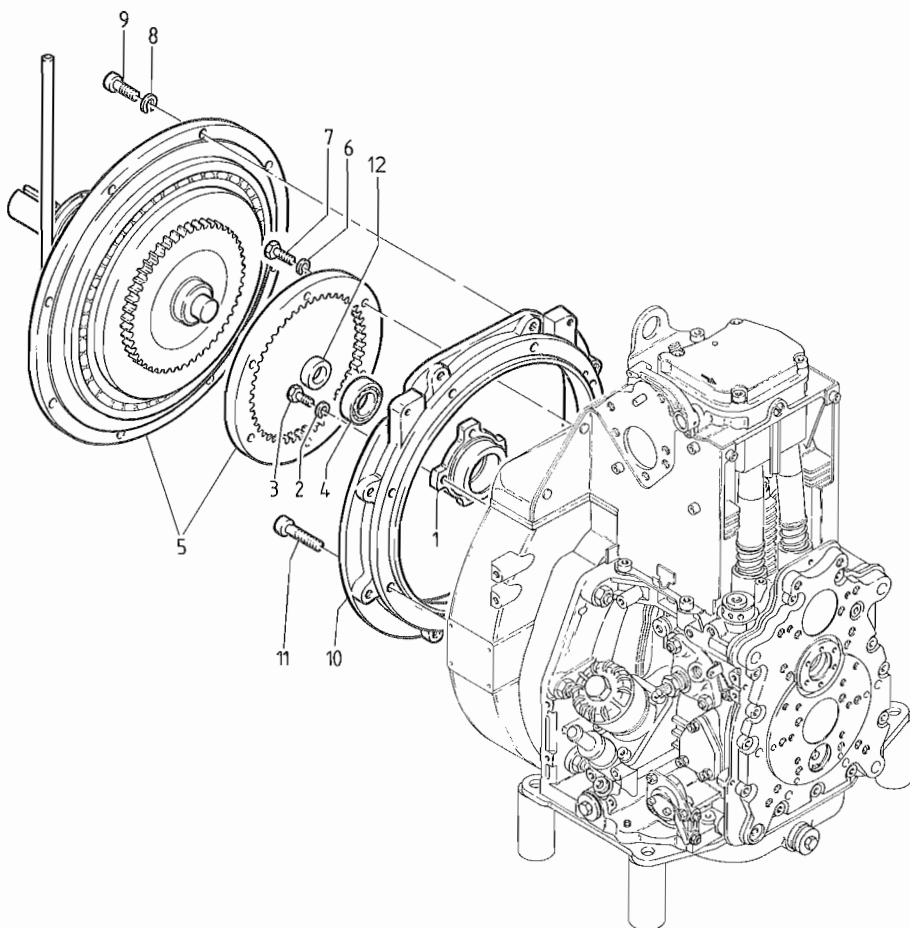

Fig.- No.	HATZ Ident-No.	Stück Qty.				P / W d / D	Bemerkungen Notes
		1D20	1D30	1D60	1D80		
			1D40				
			A1D35				
			A1D40				
1	03961200	1	1	1	1		
2	50002800	4	4	4	4	8	DIN 128
3	50026800	4	4	4	4	M 8 X 20	DIN 933-8.8
4	50014100	1	1	1	1		DIN 625 6205 2 RS
5	50349300	1	1	1	1		
6	50002800	6	6	6	6	8	DIN 128
7	50027000	6	6	6	6	M 8 X 25	DIN 933-8.8
8	50135600	8	8	8	8	10	DIN 128 A3C
9	50093400	8	8	-	-	M 10 X 30	DIN 912-8.8 A3C
9	50055200	-	-	8	8	M 10 X 60	DIN 912-8.8 A3C
10	03981200	1	1	-	-	SAE 5	
11	50327800	8	8	-	-	M 10 X 35	DIN 912-8.8 A3C
12	05019800	1	1	1	1		

A 18

Anbauteile Hydraulikpumpe
Mount. parts hydr. pump
Pièces mont.-pompe hydr.
Piezas mont. bomba hidr.
Particolari per montaggio pompa idraulica

Tafel Nr.
Tabl. No.
Tavola N.

35

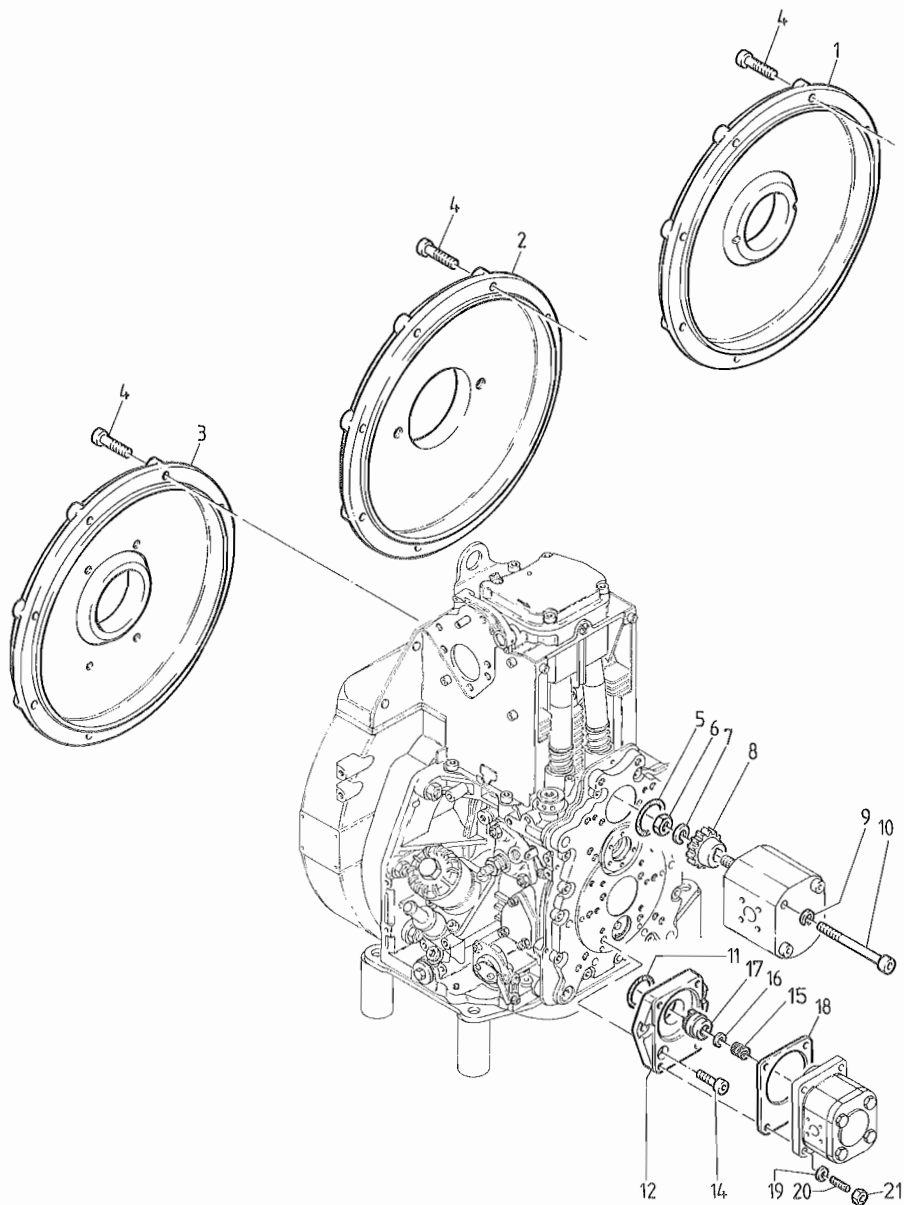

Fig.- No.	HATZ Ident-No.	Stück Qty.				P / W d / D	Bemerkungen Notes
		1D20	1D30	1D60	1D80		
			1D40				
			A1D35				
			A1D40				
1	03976300	1	1	-	-		SAE „A“ 82,55
1	03953801	-	-	1	1		SAE „A“ 82,55
2	03976200	1	1	-	-		SAE „B“ 101,6
2	03953601	-	-	1	1		SAE „B“ 101,6
3	03976700	1	1	-	-		BOSCH 80
3	03953901	-	-	1	1		BOSCH 80
4	50055200	8	8	-	-		M 10 X 60 DIN 912-8.8
4	50054700	-	-	8	8		M 10 X 45 DIN 912-8.8
5	50342500	-	-	1	1		
6	50381400	-	-	1	1		M 12 X 1,5 DIN 936-17H
7	50003000	-	-	1	1		12 DIN 128
8	04022000	-	-	1	1		
9	-----	-	-	-	-		
10	-----	-	-	-	-		
11	50375300	1	1	1	1		46 X 2,5
12	04036000	1	1	1	1		
13	-----	-	-	-	-		
14	50397900	4	4	4	4		M 10 X 22 DIN 912-8.8 A3C TUF
15	04036200	1	1	1	1		
16	50019700	1	1	1	1		J 14 X 1 DIN 472
17	04035900	1	1	1	1		
18	03568000	1	1	1	1		
19	50095100	4	4	4	4		A 8 DIN 137 A3C
20	50037800	4	4	4	4		M 8 X 22 DIN 835-5.8
21	50148000	4	4	4	4		M 8 DIN 934-8 A3C

Serien-Nr.-Änderungen
Serial-code modification list
Modification des Nos de serien
Modificación de los Nos de serie
Modifica dei codici

Bildtafel	Pos. No.	Bestell-Nr.	Stück	Bildtafel	Pos. No.	Bestell-Nr.	Stück	
Table	Fig. No.	Ordering No.	Qty.	Table	Fig. No.	Ordering No.	Qty.	IMT
Planche	Fig. No.	No. référence	Qté.	Planche	Fig. No.	No. référence	Qté.	No.
Tabla	Fig. No.	No. de pedido	Cant.	Tabla	Fig. No.	No. de pedido	Cant.	
Tavola	Rif.	Codice	Q.tà	Tavola	Rif.	Codice	Q.tà	
1D 30.10				1D 30.11			91.507	
1D 30.11				1D 30.12			92.518	
1D 30.12				1D 30.13			93.529a	
1D 35.00				1D 35.10			91.507	
1D 35.10				1D 35.11			92.518	
A1D 35.11				A1D 35.12			93.529ε	
1D 40.10				1D 40.11			90.504	
1D 40.11				1D 40.12			91.507	
1D 40.12				1D 40.13			92.518	
1D 40.13				1D 40.14			93.529	
A1D 40.10				A1D 40.11			93.529	
1D 60.12				1D 60.13			91.509	
1D 60.13				1D 60.14			91.511	
1D 60.14				1D 60.15			91.512	
1D 60.15				1D 60.16			92.524	
1D 60.16				1D 60.17			93.527	
1D 80.12				1D 80.13			91.509	
1D 80.13				1D 80.14			91.511	
1D 80.14				1D 80.15			91.512	
1D 80.15				1D 80.16			92.524	
1D 80.16				1D 80.17			93.527	

