



MOTORENFABRIK HATZ • D-94099 Ruhstorf • Germany
Tel.: 0 85 31 / 319-0 • Telex: 57260 • Telefax: 0 85 31 / 31 94 18
eMail: hatz.marketing@t-online.de • http://www.hatz.com

Original-Ersatzteile

Original-spare parts

Pièces de rechange d'origine

Repuestos originales

Pezzi di ricambio originali

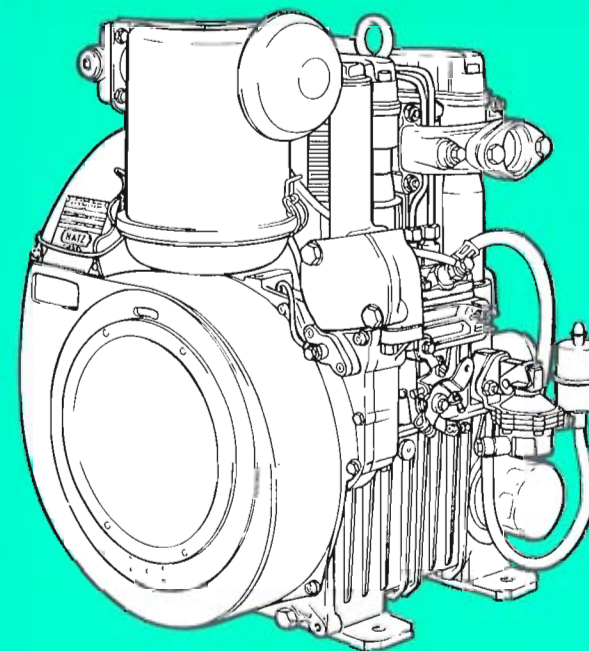

2 G 30

2 G 40

434 300 01 - 05.98 - 3
Printed in Germany
DM 3.50

Bestellung für HATZ-Original-Ersatzteile

Order for HATZ Original spare parts

Commande de pièces d'origine HATZ

Pedido de repuestos originales HATZ

Ordine parti di ricambio originali HATZ

Besteller / Customer / Client / Cliente / Cliente

TYP

MOTOR/FABRIK NO.

MIN-1



Ersatzteilliste Nr./ Spare parts list no./ Liste des pièces de rechange no./ Lista de repuestos No./ Lista ricambi n.

2 G 30 . 17 **2 G 40 . 13**

Stück / Qty / Q.tà	HATZ Ident No.	Stück / Qty / Q.tà	HATZ Ident No.

Versandart / Mode of dispatch / Mode d'expédition / Despacho deseado / Modo di spedizione

Post / Surface / Poste / Correo / Posta Luftfracht / airfreight / frêt aérien / flete aereo / Via aerea

Express / express / exprès / expreso / Espresso

Versandadresse / Consignee / Adresse destination / Dirección / Indirizzo di destinazione

- Bestellung an: Order at: Commande à: Pedido a:
- die nächste HATZ-Servicestelle (siehe Servicestellenverzeichnis)
 - your nearest HATZ service station (see service-list)
 - votre station-service HATZ la plus proche (voir liste "Service")
 - al servizio HATZ más cercano (ver cuaderno de Servicio)
 - al più vicino centro di servizio HATZ (vedi lista centri autorizzati)

MOTORENFABRIK HATZ
D-94099 RUHSTORF
Tel: 0 85 31 / 319 - 0
Fax: 0 85 31 / 31 94 21

	Inhaltsverzeichnis	Index	Tafel Nr. Table No.
M ..	Grundmotor	Basic engine	
00	Ersatzteilsätze,	Spare part kits	01
34	Zubehör	Accessories	02
01	Kurbelgehäuse	Crankcase	03
02, 05	Kurbelwelle, Kolben	Crankshaft, piston	04
06	Pleuelstange, Zylinder	conrod, cylinder	04
04, 09	Nockenwelle, Regler, Stoßstange	Camshaft, governor, pushrod	05
07	Zylinderkopf	Cylinder head	06
10, 11	Ölpumpe, Steuerdeckel	Oil pump, timing cover	07
17	Schwungrad	flywheel	07
14	Einspitzausrüstung	Injection equipment	08
26	Luftführung	Air ducting	09
27	Luftansaugrohr,	Air intake manifold,	10
32	Drehzahlverstellung	Speed control	11
A ..	Zusatzausrüstung	Equipments	
01	Kraftstoff	Fuel	12
02	Luftfilter	Air filter	13
03	Auspuff	Exhaust	14
05	Armaturenkasten	Instrument box	15
05	Starter, Generator, Öldruckschalter	Starter, alternator, oil pressure switch	16
06, 15	Motorfüße, Anschlußgehäuse	Engine brackets, intermediate housing	17
07	Zusatzölkühlung	Add. oil-cooling system	18
11	Kraftstoffabsperrentil, Hubmagnet z. Motorabstellung	Shut-off valve Lifting magnet engine stop	19
16	Wellenstummel, elast. Kupplung	Stubshaft, flexible coupling	20
17	Kupplung dauerausrückbar	Clutch perm. disconn.	21
18	Anbauteile Hydraulikpumpe	Mount. parts hydr. pump	22
			Seite/Page
Serien-Nr. Änderungen		Serial-code modification list	56

Sommaire:

Indice

M ..	Moteur de base	Motor de base	
00	Jeux de pièces de rechange	Juegos de piezas de recambios	01
34	Accessoires	Accesorios	02
01	Carter moteur	Caja ciguenal	03
02, 05	Vilebrequin, piston	Ciguenal, embolo	04
06	bielle, cylindre	biela, cilindro	04
04, 09	Arbre à cames, regulateur, tige de culbuteur	Arbol de levas, regulador, varilla de balancin	05
07	Culasse	Culata	06
10, 11	Pompe à huile, couvercle distribution,	Bomba de aceite, tapa de mando,	07
17	volant	volante	07
14	Equipment d'injection	Equipo de inyeccion	08
26	Carter ventilation	Conduccion de aire	09
27	Tube d'aspir. d'air	Tubo de conduccion,	10
32	Réglage régime	Ajuste de revoluciones	11
A ..	Accessoires	Equipos	
01	Carburant	Combustible	12
02	Filtre à air	Filtro de aire	13
03	Echappement	Escape	14
05	Boitier de bord	Cuadro de mando	15
05	Demarreur, alternateur interr. press. huile	Arrancador, alternador, interr. pres. aceite	16
06, 15	Pieds moteur, bride raccord	Soportes del motor, caja de coneccion	17
07	Refruid. d'huile sup.	Refrig. p. aceite sup.	18
11	Soupape de arret	Valvula cierre	
	El. aimant moteur stop	Elevador magn. motor stop	19
16	Bout de arbre, accouplement elastic	Eje, acoplamiento elast.	20
17	Embrayage depr. continu.	Embrague permanente	21
18	Pieces mont. pompe hydr.	Piezas mont. bomba hidraulico	22

Page/Pagina

Modification de Nos de serien

Modificación de los Nos. de serie

56

Indice	Tavola N.
M ..	Motore di base
00	Serie guarnizioni 01
34	kit accessori 02
01	Basamento motore 03
02, 05	Albero a gomito, pistone 04
06	Biella, cilindro 04
04, 09	Albero a camme, regolatore, asta bilancieri 05
07	Testa 06
10, 11	Pompa olio, coperchio distribuzione 07
17	Volano 07
14	Equipaggiamento di iniezione 08
26	Carter ventilazione 09
27	Tube aspirazione aria 10
32	Regolatore di giri 11
A ..	Accessori
01	Serbatoio e circuito combustibile 12
02	Filtro aria 13
03	Marmitta, collett. scarico 14
05	Cruscotto 15
05	Motorino avviamento, alternatore Presostato olio 16
06, 15	Staffe supporto motore, Flangiatura accoppiamento 17
07	Sistema addizionale di raffreddamento olio 18
11	Valvola per chiudere il carburante Elettrostop 19
16	Contralbero, giunto elastico 20
17	Frizione punto morto 21
18	Particolari per montaggio pompa idraulica 22
	Pagina
Modifica dei codici	56

M 00

Ersatzteilsätze
Spare parts kits
Jeux de pièces de rechange
Juegos de piezas de recambios
Serie guarnizioni

Tafel Nr.
Tabl.No.
Tavola N.

01

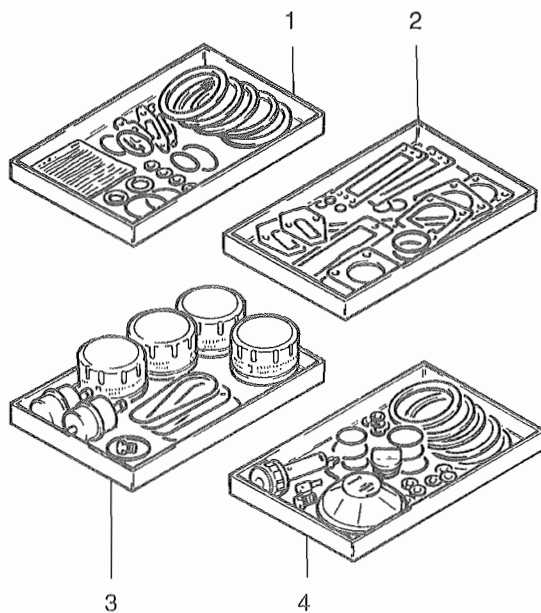

Fig.-No.	HATZ Ident-No.	Stück Qty.		P / W d / D	Bemerkungen Notes	
		2 G 30	2 G 40			
W:	Im Wartungssatz enthalten. Incl. in maintenance kit. Contenu dans le jeu d'entretien. Includido en el juego de mantenimiento. Contenuto nella serie manutenzione.				P:	Im Pannensatz enthalten. Incl. in emergency kit. Contenu dans le jeu secours. Includido en el juego para averias. Contenuto nella serie di prima necessità.
d:	Im Dichtungssatz f. 1 Zyl.-K. enth. Incl. in gasket set f. 1 cyl. head. Contenu dans le jeu de joint p. 1 culasse. Includido en el juego de juntas p. 1 culata. Contenuto nella serie guarnizioni per 1 testa.				D:	Im Dichtungssatz Kurbelgeh. Incl. in gasket set crankcase. Contenu dans le jeu de joints carter moteur. Includido en el juego de juntas caja cigueñal. Contenuto nella serie guarnizioni basamento.
					1: Anzahl pro Satz - Qty. per kit Quantite par jeu Cantidad por juego Quantità per serie	
1	01228100	2	-	P1	Dichtungssatz für 1 Zylinderkopf	
1	01247700	-	2	P1	Gasket set for 1 cyl. head Jeu de joint p. 1 culasse Juego de juntas para 1 culata Serie guarnizioni per 1 testa	
2	01228000	1	1		Dichtungssatz für Kurbelgehäuse Gasket set for crankcase Jeu de joints p. carter moteur Juego de juntas para caja cigueñal Serie guarnizioni basamento	
3	01228202	1	1		Wartungssatz für 1000 h 1000 hours maintenance kit Kit d'entretien 1000 heures - Juego de piezas para servicio 1000 horas Kit di manutenzione a 1000 ore	
4	01228303	1	-		Pannensatz - Emergency kit	
4	01247801	-	1		Kit de secours - Juego para averias Kit di prima necessità	

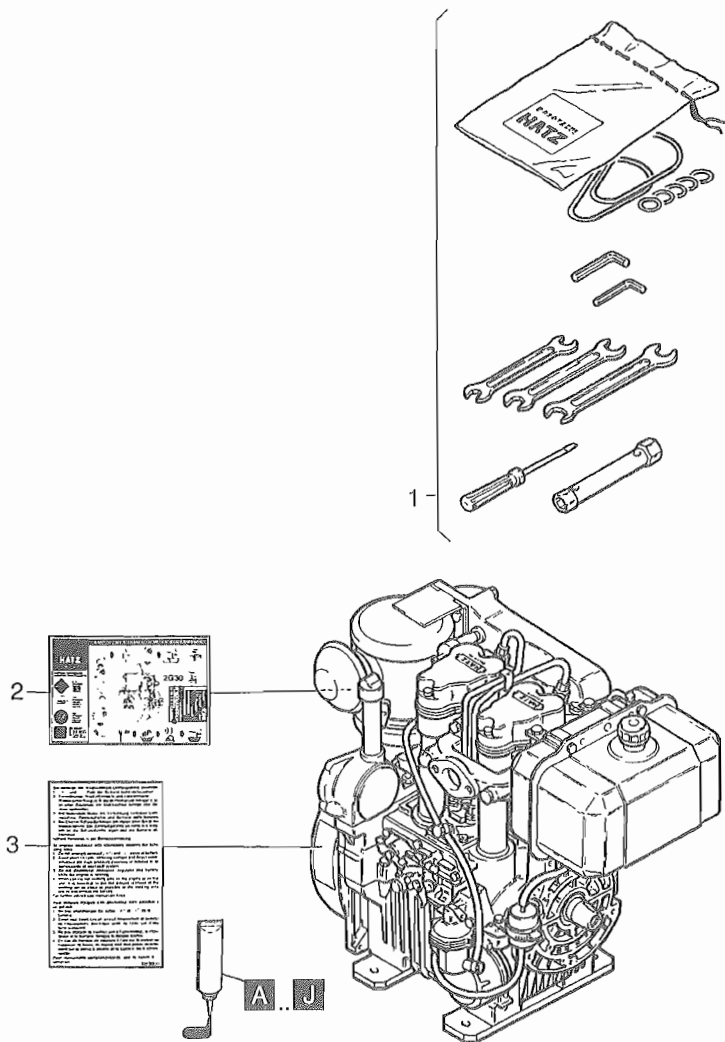

Fig.-No.	HATZ Ident-No.	Stück Qty.	P / W d / D	Bemerkungen Notes
		2 G 30	2 G 40	
1	01231000	1	1	Zubehörsatz - Accessoires kit Sort. accessoires Juego de accesorios Serie accessori
2	04009600	1	1	
3	03430612	1	1	

Dicht- und Klebstoffe

Sealing- and bonding adhesives

Etanchéifiant et Colle

Materias para empaquetar y pegar

Adesivi e collanti

A = 502 230 01	Loctite Activator N	500 ml	} siehe Hinweis auf den einzelnen Bildtafeln as specified in the individual tables suivant les remarques sur les tableau correspondant según las indicaciones de las tablas correspondientes seguire le indicazioni sul quadro corrispondente
B = 502 231 00	Loctite 573	50 ml	
C = 502 232 00	Loctite 601	50 ml	
D = 502 233 00	Loctite 221	50 ml	
E = 502 234 00	Loctite 648	10 ml	
F = 502 238 00	Technicoll 8058	0,75 kg	
+ 502 239 00	Technicoll 8367	0,75 kg	
G = 502 565 01	Loctite IS 407	20 mg	
H = 502 825 01	Silicon	30 ml	
J = 502 830 03	Hochtemp. Paste	100 ml	
K = 503 426 00	Hochtemp. Fett	100 g	

M 01

Kurbelgehäuse
Crankcase
Carter moteur
Caja cigueñal
Basamento motore

Tafel Nr.
Tabl.No.
Tavola N.

03

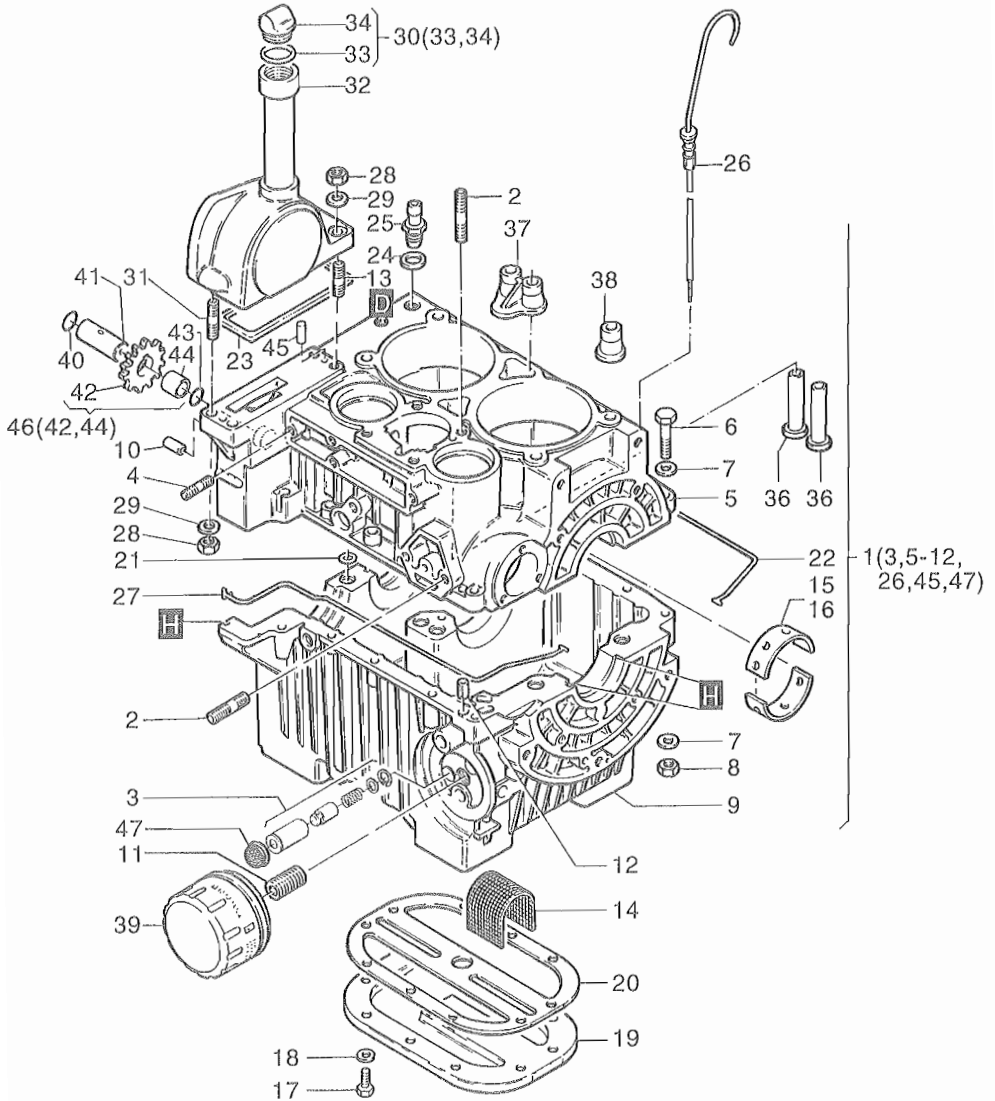

Fig.-No.	HATZ Ident-No.	Stück Qty.	P / W d / D	Bemerkungen Notes
		2 G 30	2 G 40	
1	01227411	1	1	
2	50098300	6	6	M 8 x 20 DIN 835-8.8 A3C
3	01221803	1	1	
4	50307000	1	1	M 6 x 18
5	-----	-	-	
6	50137000	10	10	M 6 x 50 DIN 931-8.8 A3C
7	50144500	21	21	6,4 DIN 125-St A3C
8	50144400	10	10	M 6 DIN 934-8 A3C
9	-----	-	-	
10	50301000	1	1	8,5 x 15
11	50302700	1	1	
12	50300700	2	2	8 H 8 x 16
13	50128100	2	2	M 8 x 30 DIN 835-10.9 A3C
14	50301400	1	1	
15	50302100	3	3	
16	50324200	3	3	0,5 -
17	50146300	10	10	M 6 x 18 DIN 933-8.8 A3C
18	04060600	10	10	6,4 x 16 x 1,5
19	50301600	1	1	
20	50301500	1	1	D1
21	50275000	8	8	D8 14 x 1,78
22	50301200	1	1	D1
23	50323500	1	1	D1
24	50001100	1	1	D3 A 12 x 15,5 DIN 7603-Cu
25	50303000	1	1	
26	50302910	1	1	
27	50301100	1	1	D1
28	50335300	4	4	M 8 SW12 A3C
29	03788800	4	4	8,4 x 15 x 2
30	00632101	1	1	W1
31	50231900	2	2	M 8 x 25 DIN 835-8.8 A3C
32	03908201	1	1	
33	50153800	1	1	D1 23 x 3
34	-----	-	-	
35	-----	-	-	

M 01

Kurbelgehäuse
Crankcase
Carter moteur
Caja cigüeñal
Basamento motore

Tafel Nr.
Tabl.No.
Tavola N.

03

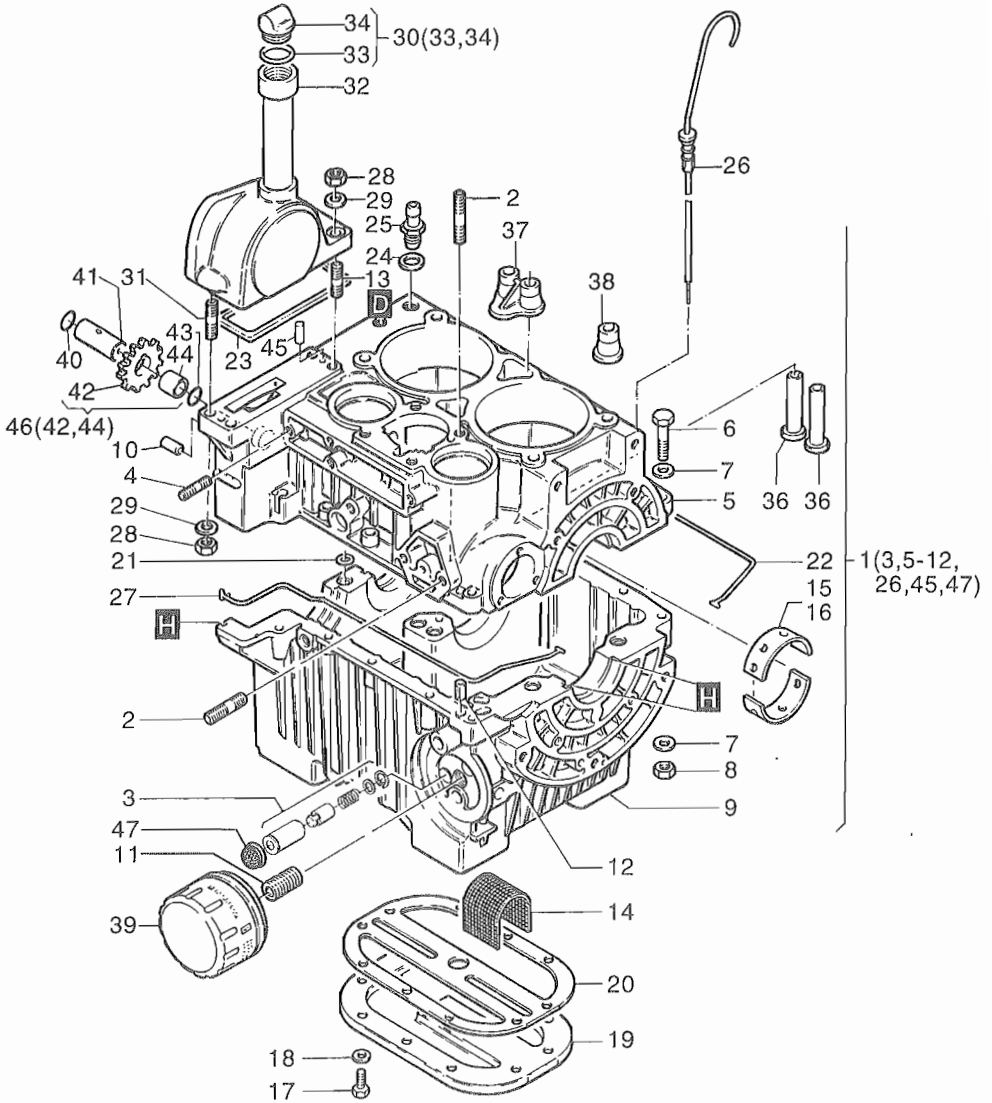

Fig.-No.	HATZ Ident-No.	Stück Qty.	P / W d / D	Bemerkungen Notes
		2 G 30	2 G 40	
36	50302000	4	4	
37	04038200	2	2	
38	04039100	4	4	
39	50302800	1	1	W4
40	50336200	1	1	D1
41	50303610	1	1	10,78 x 3,62 „H“
42	-----	-	-	
43	50195800	0...	0...	„H“ 10 x 16 x 0,5 DIN 988
44	50336110	1	1	„H“
45	50290500	2	2	6 m 6 x 14 DIN 7-9 S20K
46	01239901	1	1	„H“
47	05034900	1	1	

M 02

Kurbelwelle
Crankshaft
Vilebrequin
Cigüeñal
Albero a gomito

M 05

Kolben, Pleuelstange
Piston, Conrod
Piston, Bielle
Embolo, Biela
Pistone, Biella

M 06

Zylinder
Cylinder
Cilindro
Cilindro
Cilindro

Tafel Nr.
Tabl.No.
Tavola N.

04

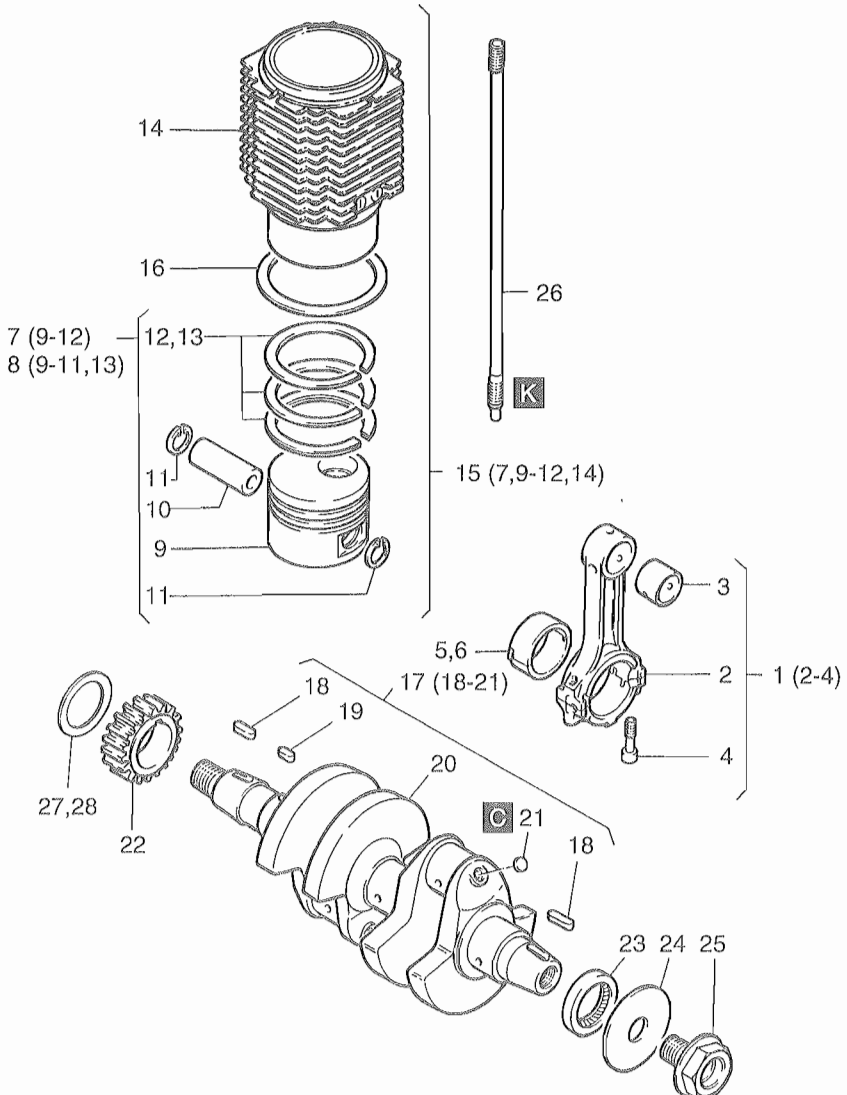

Fig.-No.	HATZ Ident-No.	Stück Qty.	P / W d / D	Bemerkungen Notes
		2 G 30	2 G 40	
1	01262200	2	2	
2	-----	-	-	
3	03785300	2	2	
4	03781100	4	4	
5	03781300	2	2	
6	03785600	2	2	- 0,5 mm
7	01300500	2	-	
7	01240203	-	2	
8	01300600	2	-	+ 0,5 mm
8	01248302	-	2	+ 0,5 mm
8	01300700	2	-	+ 1,0 mm
9	-----	-	-	
10	50314500	2	-	26 x 14 x 64 DIN 73126-B2
10	50359010	-	2	26 x 13 x 74 DIN 73126-B2
11	50314600	4	-	26 x 1,2 DIN 472
11	50359110	-	4	A 26 x 1,2
12	01223700	2	-	
12	01240300	-	2	
13	01235600	2	-	+ 0,5 mm
13	01227200	2	-	+ 1,0 mm
13	01248700	-	2	+ 0,5 mm
14	-----	-	-	
15	01301900	2	-	
15	01247100	-	2	
16	03958000	2	2	0,3 mm
17	01262700	1	1	
18	50011200	2	2	6 x 6 x 25 DIN 6885
19	50304300	1	1	6 x 6 x 10
20	-----	-	-	
21	50304100	4	4	
22	50304400	1	1	
23	50304500	1	1	D1
24	50304700	1	1	
25	50304800	1	1	M18 x 1,5
26	03781000	8	8	
27	50347500	0..1	0..1	38 x 58 x 0,2
28	50347600	0..1	0..1	38 x 58 x 0,3

M 04

Nockenwelle, Regler
Camshaft, Governor
Arbre à cames, Regulateur
Arbol de levas, Regulator
Albero a camme, Regolatore

M 09

Stoßstange
Pushrod
Tige de culbuteur
Varilla de balancin
Asta bilanciara

Tafel Nr.
Tabl.No.
Tavola N.

05

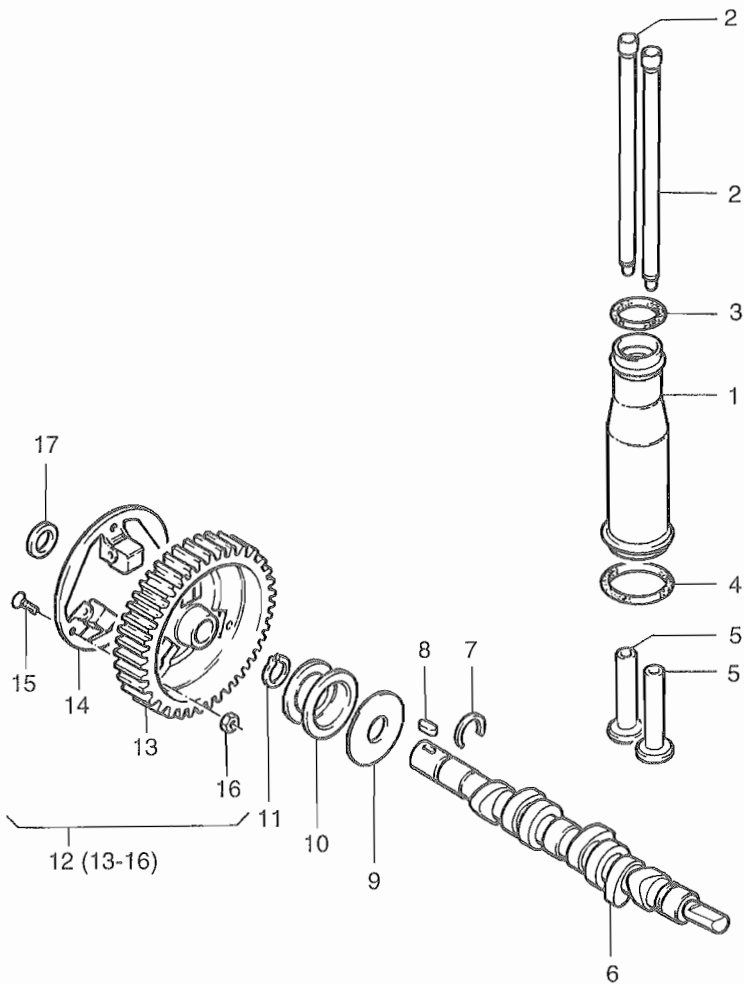

Fig.-No.	HATZ Ident-No.	Stück Qty.	P / W d / D	Bemerkungen Notes
		2 G 30	2 G 40	
1	03781800	2	2	
2	01224001	4	4	
3	50208400	2	2	d1 32 x 3
4	50290100	2	2	d1 38 x 3
5	50302000	4	4	
6	04092800	1	1	
7	50305000	1	1	17
8	50010500	1	1	4 x 4 x 12 DIN 6885
9	50306001	1	1	18 x 44 x 0,5
10	50305700	1	1	
11	50020000	1	1	18 x 1,2 DIN 471
12	01222100	1	1	
13	-----	-	-	
14	01244800	1	1	
15	50305300	3	3	M 5 x 14
16	50305400	3	3	M 5
17	03233200	1	1	19 x 32 x 0,2
17	03233300	1	1	19 x 32 x 0,3

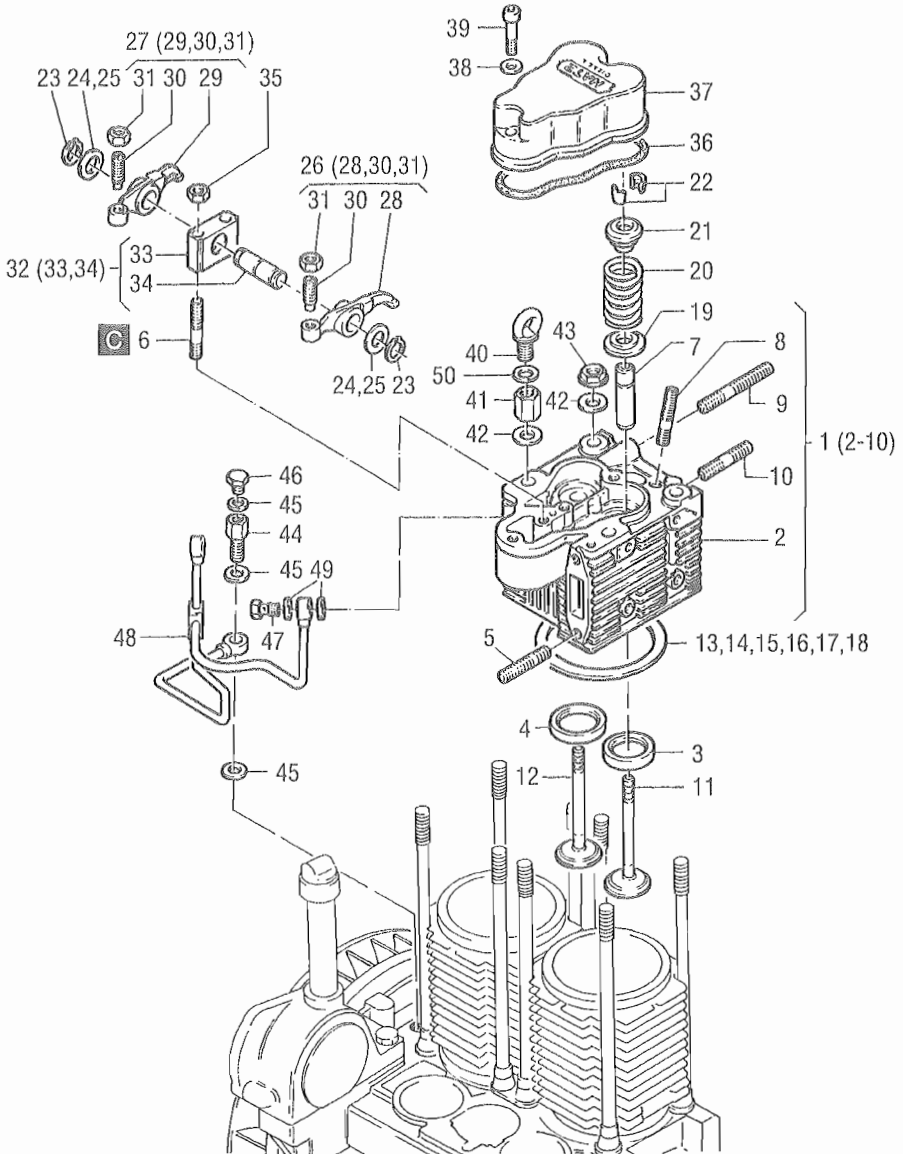

Fig.-No.	HATZ Ident-No.	Stück Qty.	P / W d / D	Bemerkungen Notes
		2 G 30	2 G 40	
1	01227800	2	-	
1	01247200	-	2	
2	-----	-	-	
3	-----	-	-	
4	-----	-	-	
5	50231900	4	4	M 8 x 25 DIN 835-8.8 A3C
6	50279200	4	4	M 8 x 40 DIN 835-8.8 A3C
7	03785200	4	4	
8	50038400	2	2	M 8 x 35 DIN 835-8.8 A3C
9	50065100	2	2	M 8 x 85 DIN 835-8.8 A3C
10	50128100	2	2	M 8 x 30 DIN 835-10.9 A3C
11	03783300	2	2	
12	03783200	2	2	
13	03793500	0..2	-	d1 0,60 mm
13	04110800	-	0..2	0,50 mm
13	04110900	-	0..2	d1 0,55 mm
13	03792800	-	0..2	0,60 mm
13	03971200	-	0..2	0,65 mm
13	03781900	0..2	-	d1 0,70 mm
13	03792900	-	0..2	d1 0,70 mm
13	03971300	-	0..2	0,75 mm
14	03782000	0..2	-	0,80 mm
14	03793000	-	0..2	0,80 mm
14	04090600	-	0..2	0,85 mm
15	03782100	0..2	-	0,90 mm
15	03793100	-	0..2	0,90 mm
15	04090700	-	0..2	0,95 mm
16	03782200	0..2	-	1,00 mm
16	03793200	-	0..2	1,00 mm
17	03782300	0..2	-	1,10 mm
17	03793300	-	0..2	1,10 mm
18	03782400	0..2	-	1,20 mm
18	03793400	-	0..2	1,20 mm
19	03783401	4	4	
20	03783500	4	4	
21	03783600	4	4	
22	03786300	4	4	

M 07

Zylinderkopf
Cylinder head
Culasse
Culata
Testa

Tafel Nr.
Tabl.No.
Tavola N.

06

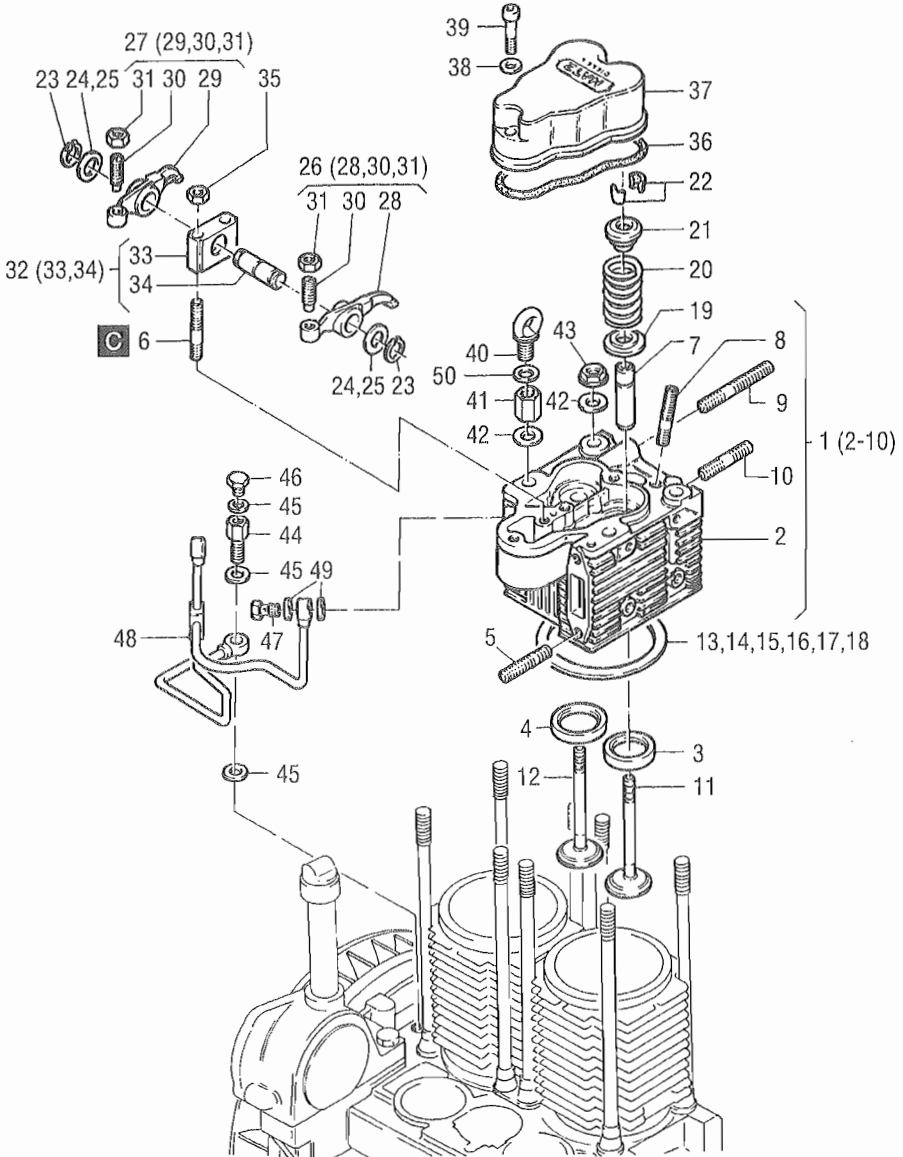

Fig.-No.	HATZ Ident-No.	Stück Qty.		P / W d / D	Bemerkungen Notes
		2 G 30	2 G 40		
23	50019800	4	4		A 15 x 1 DIN 471
24	50315900	0..4	0..4		15 x 21 x 0,2
25	50316000	0..4	0..4		15 x 21 x 0,3
26	01224500	2	2		
27	01224400	2	2		
28	-----	-	-		
29	-----	-	-		
30	03783000	4	4		
31	03173100	4	4	W2	
32	01224600	2	2		
33	-----	-	-		
34	-----	-	-		
35	40028400	4	4	P2	VM8 DIN 980-8 C3A
36	50290200	2	2	W4, d1	115,6 x 121 x 3,1
37	03783800	2	2		
38	50162900	4	4	W8, d2	A 8 x 14 DIN 7603-Cu
39	50177500	4	4		M 8 x 40 DIN 912-8.8 A3C
40	50315500	1	1		M 10 DIN 580 A3C
41	03784501	5	5	P2	
42	03791400	8	8	P4	
43	03171800	3	3	P2	
44	50314001	1	1		
45	50000900	4	4		A 8 x 11,5 DIN 7603-Cu
46	50033300	1	1		M 8 x 1 x 12 DIN 961-8.8
47	50006100	2	2		4-5-3 DIN 7643
48	01224900	1	1		
49	50000900	4	4	d2	A 8 x 11,5 DIN 7603-Cu
50	03787300	0..2	0..2		0,2 mm

M 10

Ölpumpe
Oil pump
Pompe à huile
Bomba de aceite
Pompa olio

M 11

Steuerdeckel
Timing cover
Couvercle distr.
Tapa de mando
Coperchio distrib.

M 17

Schwungrad
Flywheel
Volant
Volante
Volano

Tafel Nr.
Tabl.No.
Tavola N.

07

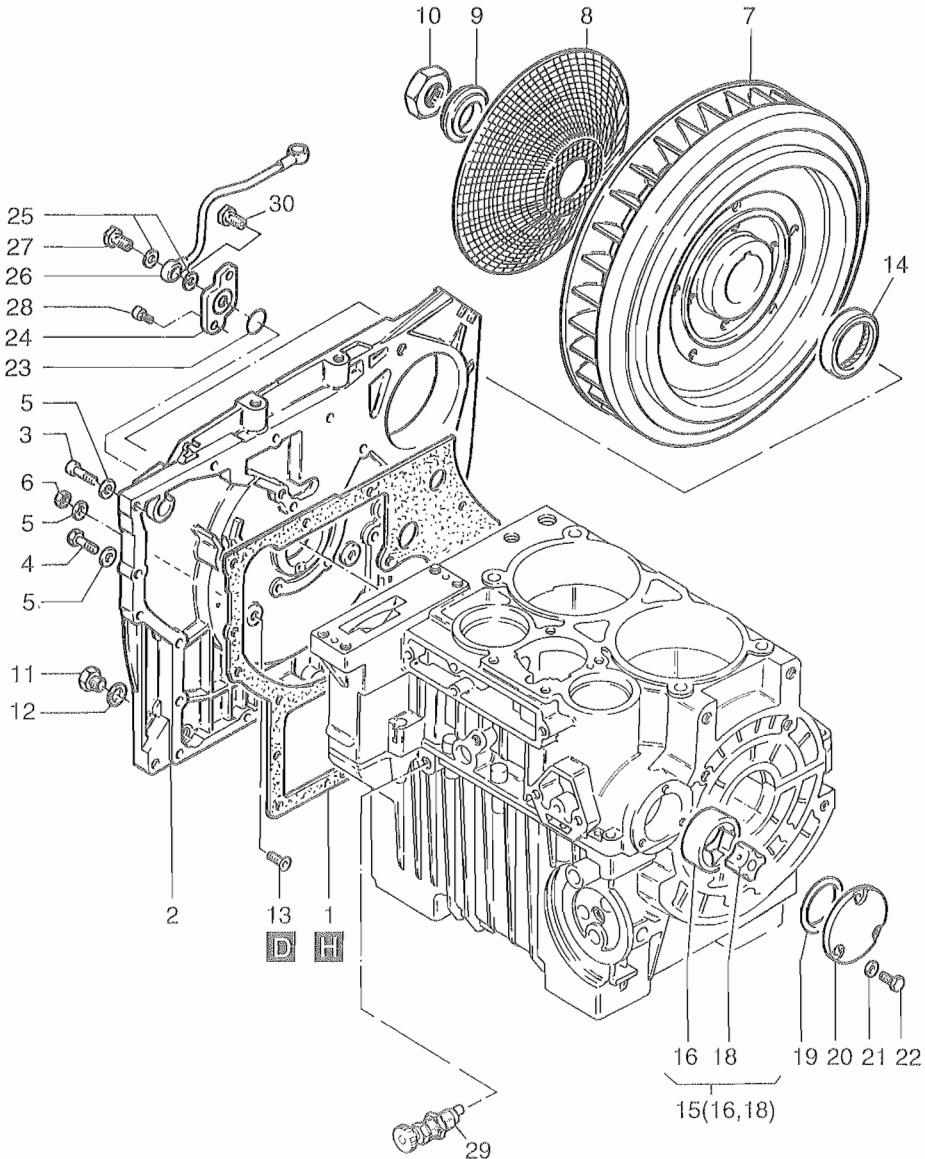

Fig.-No.	HATZ Ident-No.	Stück Qty.		P / W d / D	Bemerkungen Notes
		2 G 30	2 G 40		
1	50311500	0..2	0..2	D2	0,2 mm
2	50310810	1	1		
3	50026400	1	1		M 6 x 35 DIN 933-8.8 A3C
4	50092100	18	18		M 6 x 25 DIN 933-8.8 A3C
5	50144500	18	18		6,4 DIN 125-St A3C
6	50144400	3	3		M6 DIN 934-8 A3C
7	03792100	1	1		
8	50313400	1	1		
9	03975300	1	1		
10	04031300	1	1		
11	50311000	1	1	W1	M 14 x 1,5
12	50001200	1	1	W4, D1	A 14 x 18 DIN 7603-Cu
13	50310900	3	3		
14	50311200	1	1	D1	38 x 52 x 8
15	01227910	1	1		
16	-----	-	-		
17	-----	-	-		
18	-----	-	-		
19	50310500	1	1	D1	41 x 1,78
20	50310410	1	1		
21	50216300	3	3		5,3 DIN 125-St A3C
22	50025200	3	3		M 5 x 16 DIN 933-8.8 A3C
23	50336500	1	1		15,88 x 2,62
24	50336400	1	1		
25	50000900	1...2	1...2	D5	„H“ A 8 x 11,5DIN 7603-Cu
26	50336300	1	1		„H“ s.Tafel/Tabl. 16, Fig.-No. 15 ...
27	50006100	1	1		„H“ 4-5-3 DIN 7643
28	50274500	2	2		M 5 x 12 DIN 912-8.8 A3C
29	01231501	1	1		
30	50033300	1	1		M 8 x 1 x 12 DIN 961-8.8 A3C

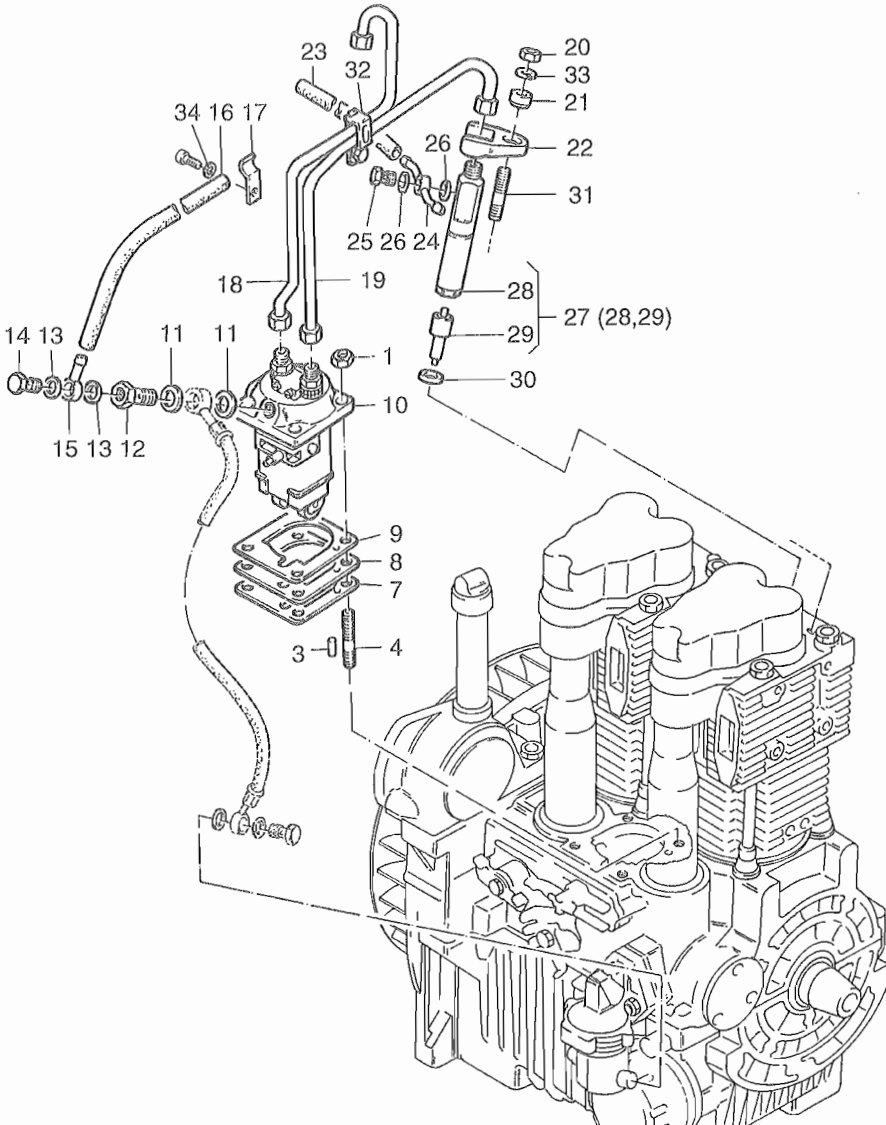

Fig.-No.	HATZ Ident-No.	Stück Qty.		P / W d / D	Bemerkungen Notes
		2 G 30	2 G 40		
1	50148000	4	4		M 8 DIN 934-8 A3C
2	-----	-	-		
3	50312200	1	1		4 H8 x 12 DIN 7
4	50098300	4	4		M 8 x 20 DIN 835-8.8 A3C
5	-----	-	-		
6	-----	-	-		
7	50312300	0..2	0..2	D2	0,10 mm
8	50312400	0..1	0..1	D1	0,20 mm
9	50312500	0..2	0..2	D2	0,30 mm
10	50355400	1	1		
11	50001100	2	2	D3	A 12 x 15,5 DIN 7603-Cu
12	01223200	1	1	P1	
13	50000900	2	2	D5	A 8 x 11,5 DIN 7603-Cu
14	50311700	1	1		
15	50015700	1	1		NW3
16	03902000	1	1		3,5 / 390
17	03174700	1	1		
18	01240900	1	1		
19	01241000	1	1		
20	50148000	2	2	P2	M 8 DIN 934-8 A3C
21	04035700	2	2	P1	
22	03792400	2	2		
23	03780700	1	1		3,5 / 130
24	03780800	2	2		
25	50313000	2	2		M 6
26	50313100	4	4	d2	A 6 x 10 DIN 7603-Cu
27	50355500	2	2		
28	-----	-	-		
29	50355600	2	2	P1	
30	40085001	2	2	d1	
31	50038400	2	2		M 8 x 35 DIN 835-8.8 A3C
32	50314100	1	1		
33	50208500	2	2	P2	8 DIN 128 A3C
34	50144500	1	1		6,4 DIN 125-St A3C

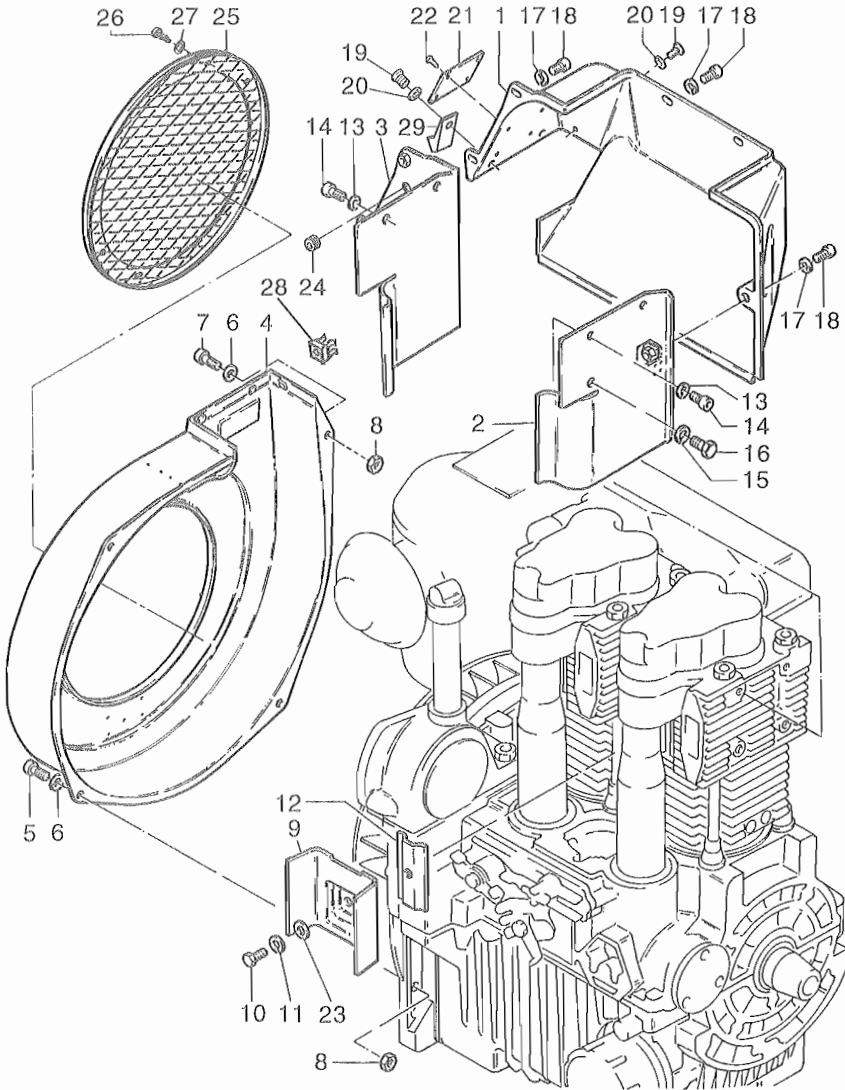

Fig.-No.	HATZ Ident-No.	Stück Qty.	P / W d / D	Bemerkungen Notes
		2 G 30	2 G 40	
1	03784400	1	1	
2	01225900	1	1	
3	01225800	1	1	
4	50314200	1	1	
5	50170700	3	3	M 6 x 16 DIN 912-8.8 A3C
6	50144500	4	4	6,4 DIN 125-St A3C
7	50170600	1	1	M 6 x 20 DIN 912-8.8 A3C
8	50144400	4	4	M 6 DIN 934-8 A3C
9	03784300	1	1	
10	50165500	1	1	M 6 x 12 DIN 933-8.8 A3C
11	50170900	1	1	6 DIN 128 A3C
12	01226100	1	1	
13	50170900	4	4	6 DIN 128 A3C
14	50170700	4	4	M 6 x 16 DIN 912-8.8 A3C
15	50208500	2	2	8 DIN 128 A3C
16	50098500	2	2	M 8 x 16 DIN 933-8.8 A3C
17	50144500	5	5	6,4 DIN 125-St A3C
18	50333800	5	5	M 6 x 12 DIN 912-8.8 A3C
19	50334600	3	3	M 4 x 12 DIN 912-8.8 A3C
20	50315400	3	3	B 4 DIN 137 A3C
21	03225504	1	1	
22	40002500	4	4	2,4
23	50144500	1	1	6,4 DIN 125-St
24	50334800	1	1	10
25	01140701	1	1	
26	50334900	4	4	B 4,2 x 9,5 DIN 7981 A3C
27	50147200	4	4	4,3 DIN 125-St A3C
28	50408500	3	3	M 4
29	50326800	0..4	0..4	

M 27

Luftansaugrohr
Air intake manifold
Tube d'aspir. d'air
Tubo de conduccion
Collettore aspirazione

Tafel Nr.
Tabl.No.
Tavola N.

10

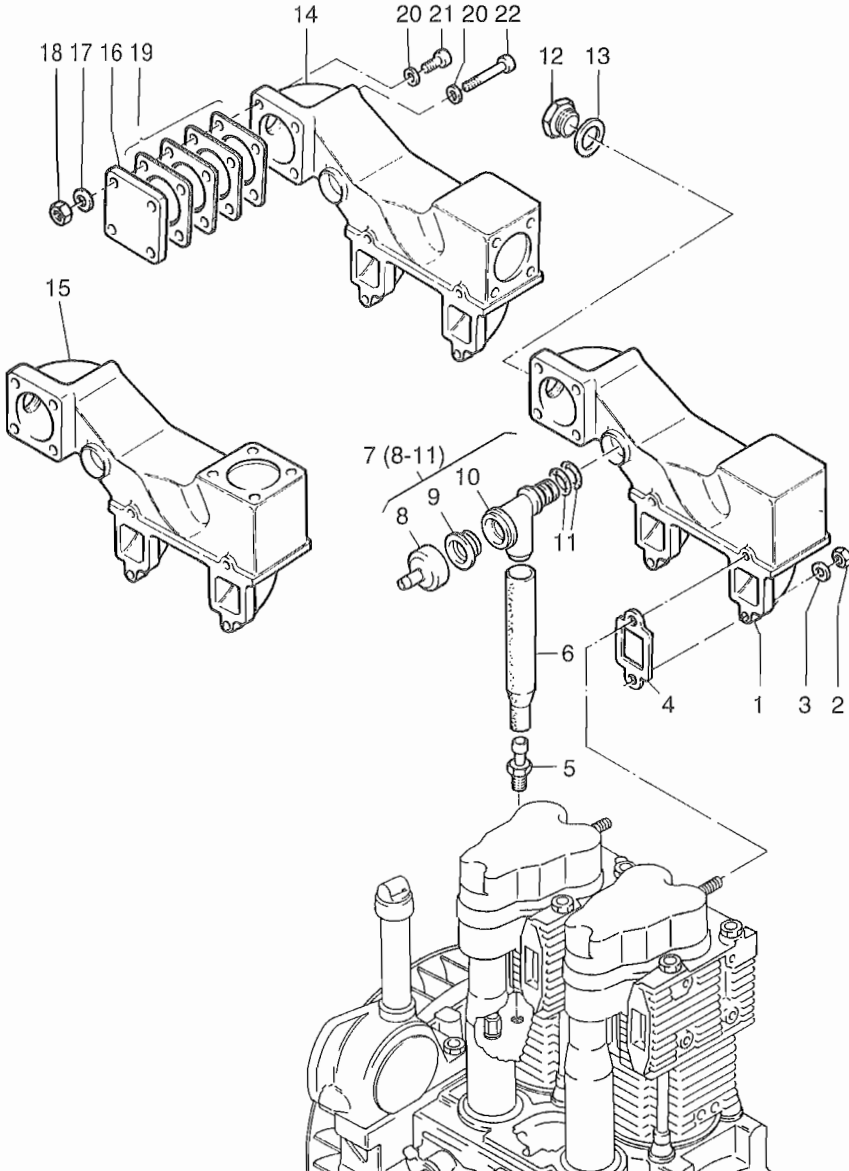

Fig.-No.	HATZ Ident-No.	Stück Qty.	P / W d / D	Bemerkungen Notes
		2 G 30	2 G 40	
1	03784121	1	1	
2	40028400	4	4	VM 8 DIN 980-8 C3A
3	50095100	4	4	8 DIN 137 A3C
4	03783902	2	2	d1
5	50303000	1	1	
6	03784001	1	1	
7	01225610	1	1	
8	03568600	1	1	
9	03568700	1	1	
10	-----	-	-	
11	50326200	2	2	11,3 x 2,4
12	50140400	1	1	AM 22 x 1,5 DIN 7604 A3C
13	50001600	1	1	d1 A 22 x 27 DIN 7603-Cu
14	03787402	1	1	
15	03943001	1	1	
16	03939700	1	1	
17	50208500	4	4	8 DIN 128 A3C
18	50148000	4	4	M 8 DIN 934-8 A3C
19	01285600	1	1	
20	50148100	4	4	8,4 DIN 125-St A3C
21	50175900	2	2	M 8 x 30 DIN 912-8.8 A3C
22	50183100	2	2	M 8 x 90 DIN 912-8.8 A3C

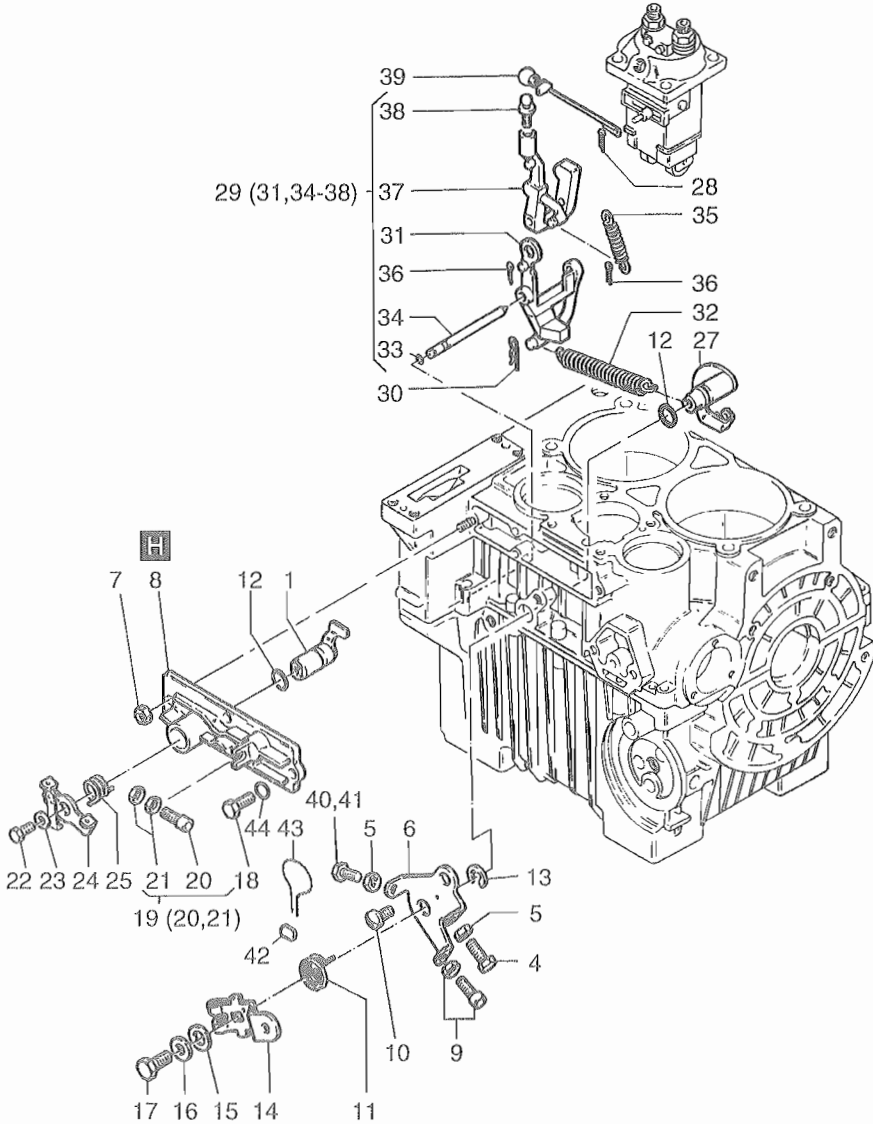

Fig.-No.	HATZ Ident-No.	Stück Qty.	2 G 30	2 G 40	P / W d / D	Bemerkungen Notes
			2 G 30	2 G 40		
1	01222300	1	1			
2	-----	-	-			
3	-----	-	-			
4	50092100	1	1			M 6 x 25 DIN 933-8.8 A3C
5	50144400	2	2			M 6 DIN 934-8 A3C
6	50308901	1	1			
7	50144400	1	1			M6 DIN 934-8 A3C
8	50306200	1	1			
9	50309100	1	1			
10	50309200	1	1			M 8 x 12
11	50309300	1	1			
12	50306500	2	2	D2		8,73 x 1,78
13	50308800	1	1			
14	50309400	1	1			
15	50309500	1	1			12,5 x 18 x 3
16	50114300	1	1			6,4 DIN 7349 A3C
17	50025400	1	1			M 6 x 10 DIN 933-8.8 A3C
18	50146300	3	3			M 6 x 18 DIN 933-8.8 A3C
19	50306900	1	1			
20	-----	-	-			
21	50144400	2	2			M 6 DIN 934-8 A3C
22	50025400	1	1			M 6 x 10 DIN 933-8.8 A3C
23	50144500	1	1			6,4 DIN 125-St A3C
24	01266500	1	1			
25	50306600	1	1			
26	-----	-	-			
27	04088300	1	1			
28	50036000	1	1			2 x 10 DIN 94
29	01222510	1	1			
30	50308500	1	1			
31	-----	-	-			
32	50355100	1	1			...2000 min ⁻¹
32	04020200	1	1			0,8 mm Ø n > 2000...2300 min ⁻¹
32	03791900	1	-			1,0 mm Ø n > 2300...3000 min ⁻¹
32	04086300	-	1			0,95 mm Ø n > 2300...3000 min ⁻¹
32	04022300	1	-			0,70 mm Ø n = 1500 min ⁻¹ Gen.
32	04086400	-	1			0,65 mm Ø n = 1500 min ⁻¹ Gen.

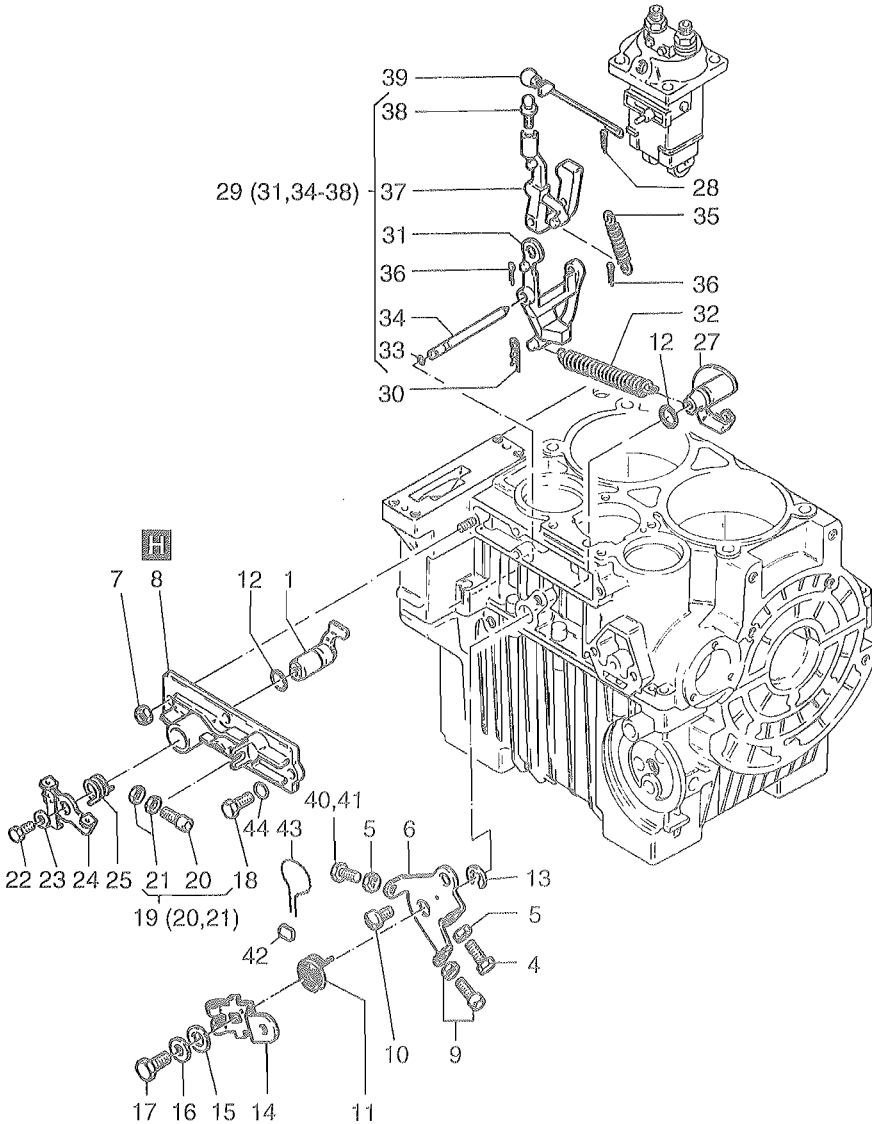

Fig.-No.	HATZ Ident-No.	Stück Qty.	P / W d / D	Bemerkungen Notes	
		2 G 30	2 G 40		
33	50308100	2	2	D2	2,9 x 1,78
34	50307900	1	1		
35	50308300	1	1		
36	50308400	2	2		1,6 x 8 DIN 94
37	-----	-	-		
38	-----	-	-		
39	01222400	1	1		
40	03791600	1	1		M 6 x 30 n < 2500 min ⁻¹
41	50344900	1	1		M 6 x 25 n > 2500 min ⁻¹
42	40021400	1	1		8 mm
43	40021500	1	1		0,5 / 0,3
44	50313100	3	3		A 6 x 10 DIN 7603-Cu

Kraftstoff
 Fuel
A 01 Carburant
 Combustible
 Serbatoio e circuito carburante

Tafel Nr.
 Tabl.No.
 Tavola N.

12

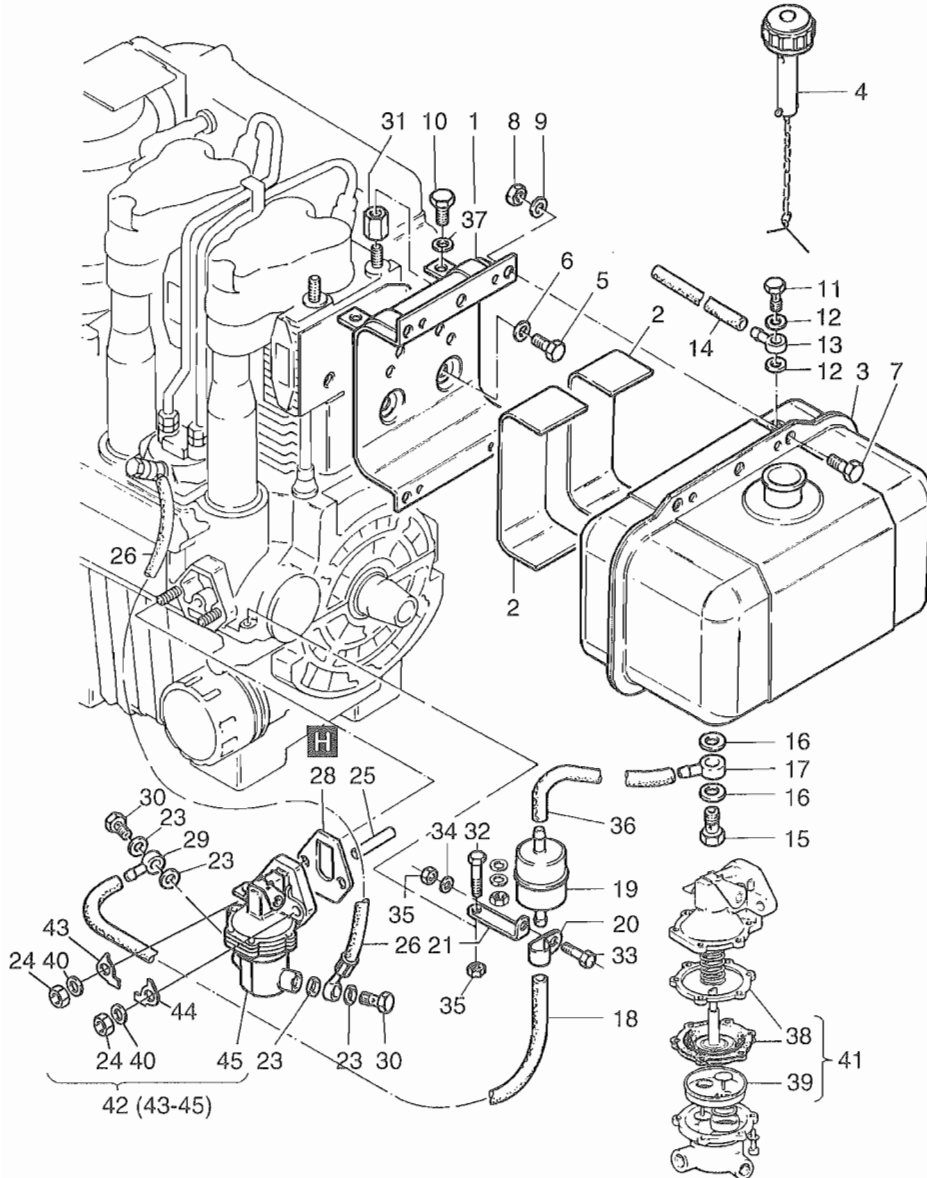

Fig.-No.	HATZ Ident-No.	Stück Qty.	2 G 30	2 G 40	P / W d / D	Bemerkungen Notes
			2 G 30	2 G 40		
1	03918900	1	1			
2	50291900	2	2			
3	50291700	1	1			
4	01125300	1	1	P1		
5	50135400	2	2		M 8 x 20	DIN 933-8.8 A3C
6	50148100	2	2		8,4	DIN 125-St A3C
7	50098500	4	4		M 8 x 16	DIN 933-8.8 A3C
8	50148000	4	4		M 8	DIN 934-8 A3C
9	50208500	4	4		8	DIN 128- A3C
10	50092200	2	2		M 10 x 16	DIN 933-8.8 A3C
11	50006100	1	1	P1	4-5-3	DIN 7643
12	50000900	2	2		A 8 x 11,5	DIN 7603-Cu
13	50015700	1	1		NW3	
14	03962100	1	1		3,5 / 180	
15	50006400	1	1		10-3	DIN 7643
16	50001200	2	2	W4	A 14 x 18	DIN 7603-Cu
17	50015900	1	1		NW 8/6	
18	03493200	1	1		7/280	
19	40089401	1	1	W2		
20	03165500	1	1			
21	03938200	1	1			
22	-----	-	-			
23	50001000	4	4		A 10 x 16	DIN 7603-Cu
24	50148000	2	2		M 8	DIN 934-8 A3C
25	50291500	1	1			
26	50291000	1	1			
28	04118500	0..1	0..1	D1	1,0 mm	
28	04118600	0..1	0..1	D1	1,4 mm	
29	40092600	1	1		NW 4/6	
30	50006200	2	2		6-3	DIN 7643
31	03784500	2	2		M 10	
32	50328500	1	1		M 6 x 65	DIN 933-8.8 A3C
33	50165500	1	1		M 6 x 12	DIN 933-8.8 A3C
34	50144500	1	1		6,4	DIN 125-St A3C
35	50144400	1	1		M 6	DIN 934-8 A3C
36	03525500	1	1		7/180	
37	50145900	2	2		10,5	DIN 125-St A3C
38	-----	-	-			
39	-----	-	-			

Fig.-No.	HATZ Ident-No.	Stück Qty.	P / W d / D	Bemerkungen Notes
		2 G 30	2 G 40	
40	50095100	2	2	A 8 DIN 137 A3C
41	50467900	1	1	Reparatursatz, repair kit
42	01601300	1	1	
43	04132500	1	1	
44	04132400	1	1	
45	-----	-	-	

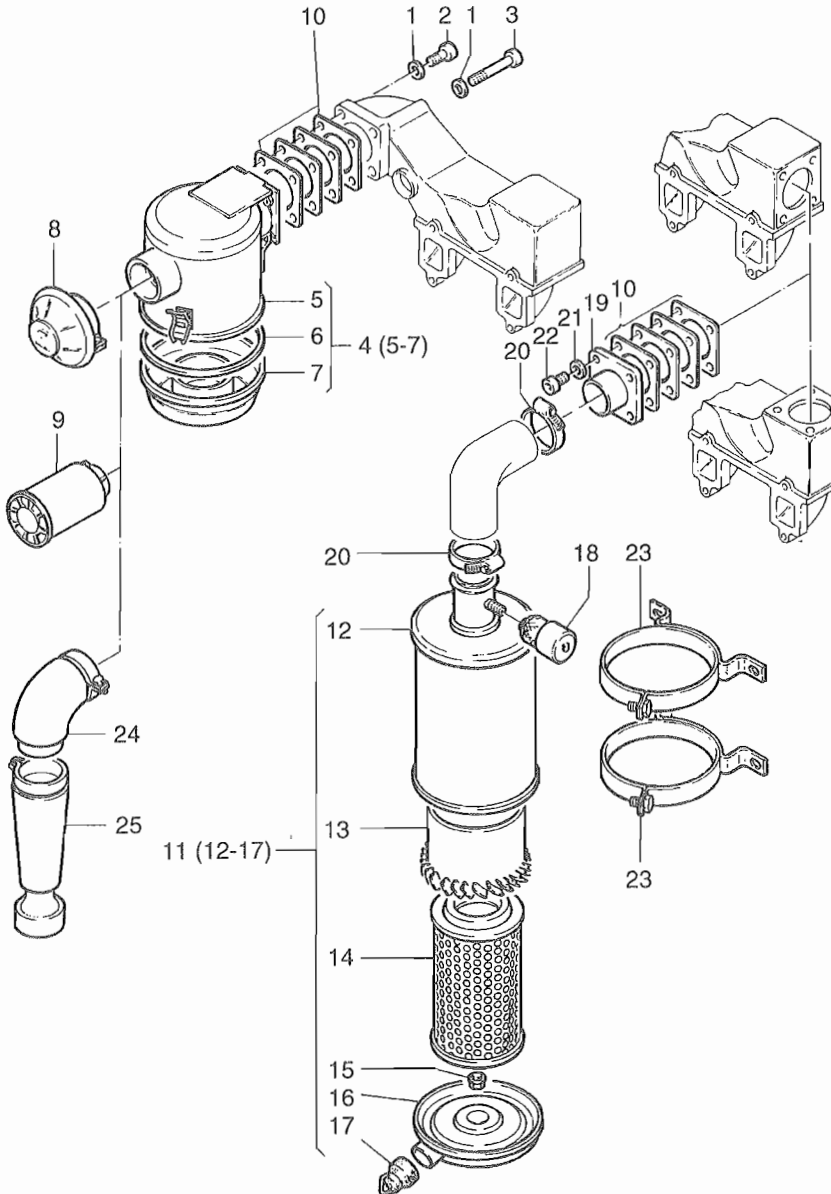

Fig.-No.	HATZ Ident-No.	Stück Qty.	P / W d / D	Bemerkungen Notes
		2 G 30	2 G 40	
1	50148100	4	4	8,4 DIN 125-St A3C
2	50175900	2	2	M 8 x 30 DIN 912-8.8 A3C
3	50183100	2	2	M 8 x 90 DIN 912-8.8 A3C
4	01122210	1	1	
5	-----	-	-	
6	49038000	1	1	P1
7	49059500	1	1	
8	40040400	1	1	P1
9	01035900	1	1	
10	01285600	1	1	
11	50367800	1	1	
12	-----	-	-	
13	-----	-	-	
14	49061600	1	1	
15	-----	-	-	
16	-----	-	-	
17	-----	-	-	
18	50333000	1	1	
19	01198900	1	1	50
20	40095500	2	2	50 - 70
21	50208500	4	4	8 DIN 128 A3C
22	50206300	4	4	8 x 18 DIN 912-8.8 A3C
23	50367900	2	2	
24	01193000	1	1	
25	01193100	1	1	

A 03

Auspuff
Exhaust
Echappement
Escape
Scarico

Tafel Nr.
Tabl.No.
Tavola N.

14

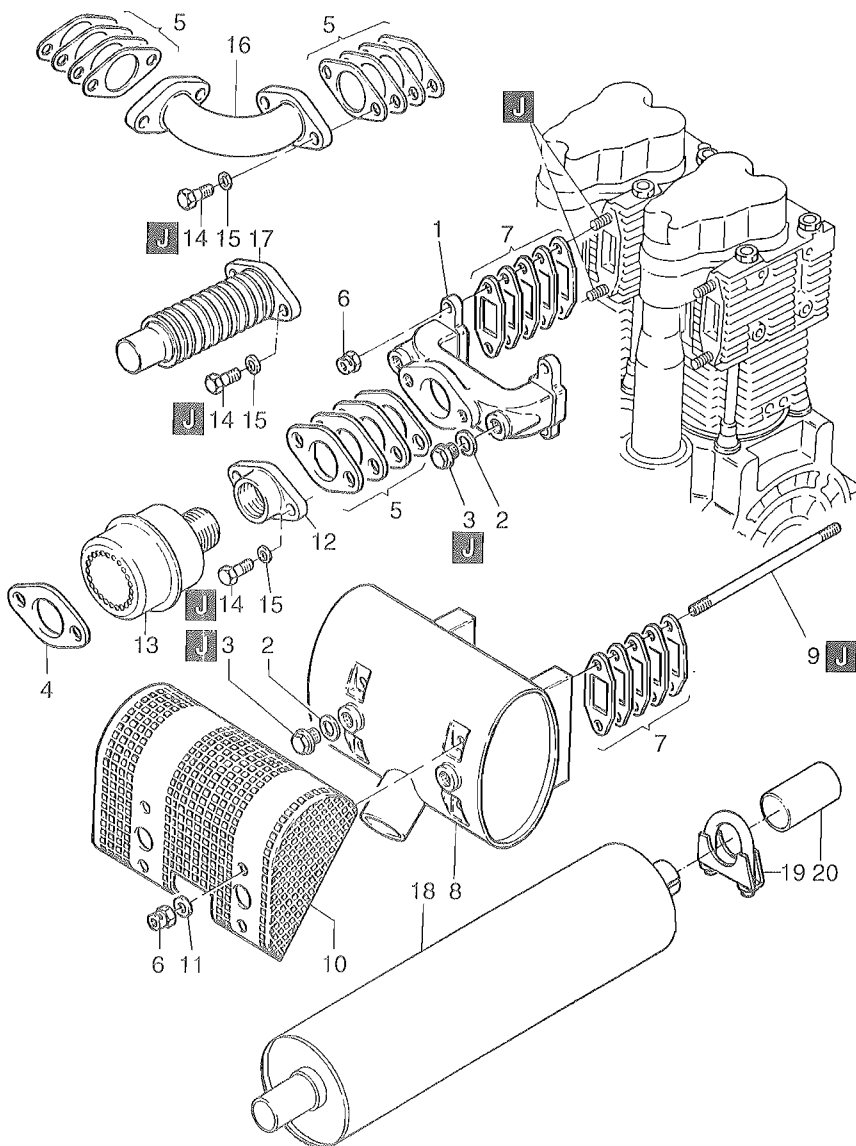

Fig.-No.	HATZ Ident-No.	Stück Qty.	P / W d / D	Bemerkungen Notes
		2 G 30	2 G 40	
1	03919800	1	1	
2	03228800	2	2	d1
3	50044700	2	2	R 1/4 DIN 910-5.8 A3C
4	50060600	1	1	42 x 68 DIN 71501
5	01285800	1	1	
6	40028400	4	4	VM 8 DIN 980-8 C3A
7	01285500	2	2	d1
8	01129000	1	1	
9	50292600	4	4	8 x 185 DIN 835-8.8
10	01139500	1	1	
11	50148100	4	4	8,4 DIN 125-St A3C
12	03829100	1	1	R 1 1/4
13	00872200	1	1	R 1 1/4
14	50327200	2	2	M 10 x 25 DIN 933-8.8 C4P
15	50135600	2	2	10 DIN 128 A3C
16	01139700	1	1	
17	50323100	1	1	
18	01050700	1	1	
19	50339800	1	1	
20	03848500	1	1	

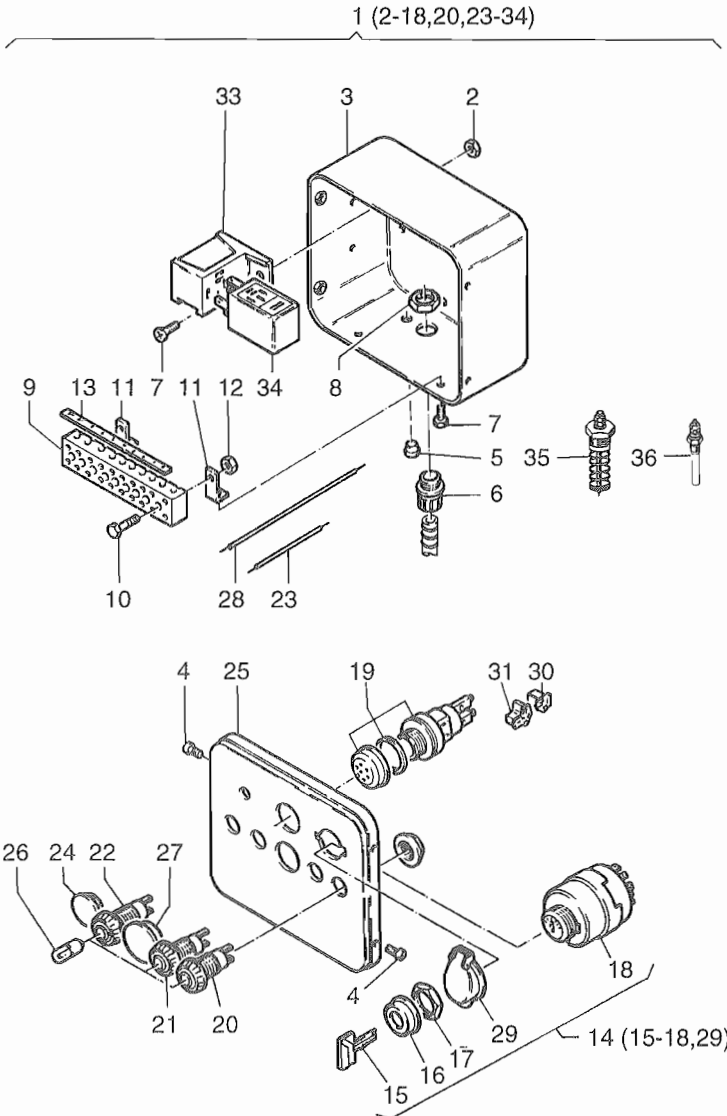

Fig.-No.	HATZ Ident-No.	Stück Qty.	2 G 30	2 G 40	P / W d / D	Bemerkungen Notes
			2 G 30	2 G 40		
1	01112802	1	1			12 V
2	40028200	2	2			M 5
3	00716311	1	1			
4	50289200	4	4			M 6 x 12 KZ1 8.8 A3D
5	50160800	2	2			F 5
6	50159011	1	1			13,5
7	50049300	4	4			M 5 x 10 DIN 7985-8.8 A3R
8	50159100	1	1			
9	50160700	1	1			
10	50158800	2	2			M 4 x 20 DIN 84-4.8 A3C
11	03666700	2	2			
12	50147100	2	2			M 4 DIN 934-8 A3C
13	05004300	1	1			
14	50276502	1	1			
15	50345300	1	1	P1		
16	-----	-	-			
17	-----	-	-			
18	-----	-	-			
19	40068600	1	1			
20	50176500	1	1			BATT
21	50176600	1	1			OIL
22	50176400	1	1			TEMP.
23	01090201	1	1			
24	40096000	2	2			F 17
25	03509211	1	1			
26	40009700	3	3			12 V, 2 W
27	40091400	2	2			F 24
28	01150101	1	1			
29	49050900	1	1			
30	50276600	1	1			4-P
31	50276700	1	1			6-P
32	-----	-	-			
33	50276000	2	2			
34	50277701	2	2			12 V
35	50163900	1	1			184G
36	50344500	1	1			TEMP.

A 05

Starter, Generator, Öldruckschalter
Starter, Alternator, Oil pressure switch
Démarreur, Alternateur, Interr. press huile
Arrancador, Alternador, Interr. pres. aceite
Motorino avviamento, Alternatore, Pressostato olio

Tafel Nr.
Tabl.No.
Tavola N.

16

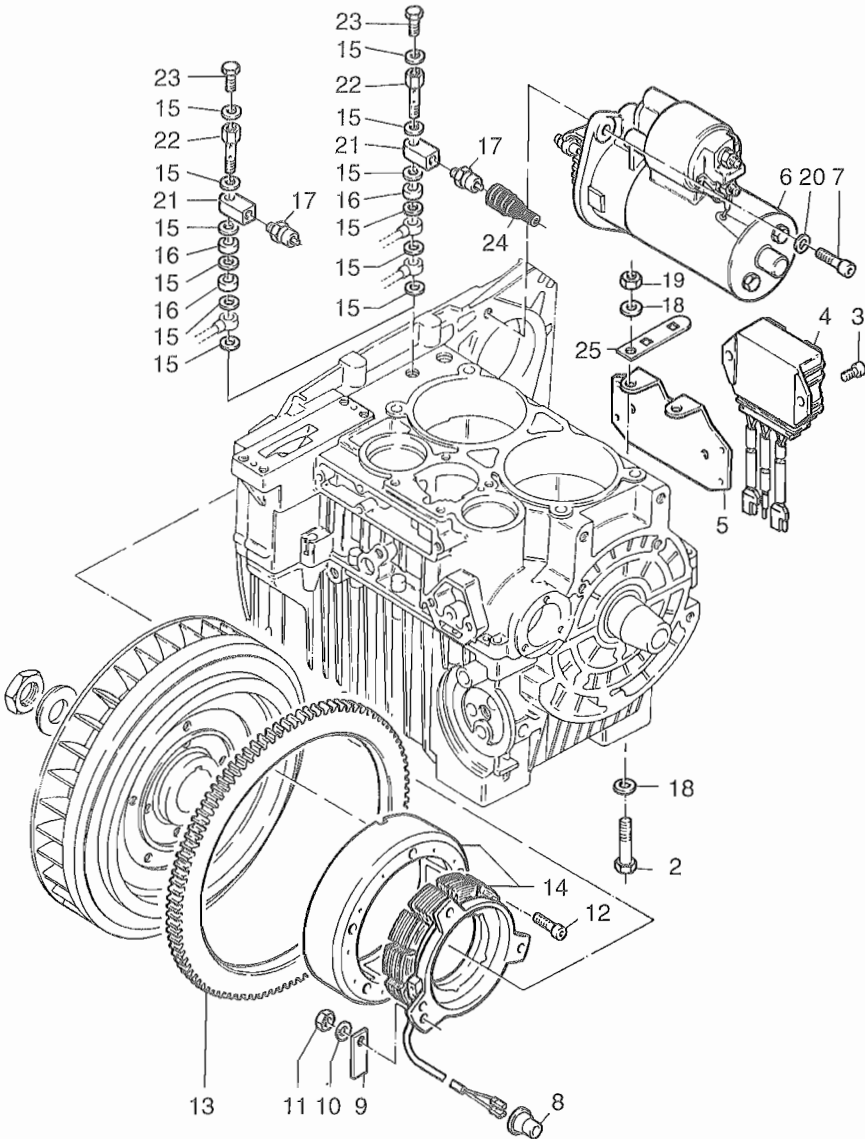

Fig.-No.	HATZ Ident-No.	Stück Qty.	P / W d / D	Bemerkungen Notes
		2 G 30	2 G 40	
1	-----	-	-	
2	50383700	2	2	M 6 x 55 DIN 931-8.8 A3C
3	50165400	2	2	M 8 x 16 DIN 912-8.8 A3C
4	50283811	1	1	12 V
4	50364500	1	1	24 V
5	03958100	1	1	
6	50316402	1	1	12 V, 1,8 KW
6	50364400	1	1	24 V, 2,5 KW
7	50093400	2	2	M 10 x 30 DIN 912-8.8 A3C
8	04039100	1	1	
9	50293500	1	1	
10	50144500	3	3	6,4 DIN 125-St A3C
11	50144400	3	3	M 6 DIN 934-8 A3C
12	50323900	5	5	M 6 x 30 DIN 912-8.8 A3C
13	03792200	1	1	
14	50292810	1	1	12 V, 280 W
15	50000900	6	6	A 8 x 11,5 DIN 7603-Cu
16	03790100	1...2	1...2	8,4 x 12 x 10
17	50293810	1	1	
18	50144500	2	2	6,4 DIN 125-St A3C
19	50144400	2	2	M 6 DIN 934-8 A3
20	50145900	2	2	10,5 DIN 125 A3C
21	03932100	1	1	
22	03790001	1	1	
23	50033300	1	1	M 8 x 1 x 12 DIN 961-8.8 A3C
24	50329400	1	1	
25	03926200	1	1	

A 06

Motorfüße
Engine bracket
Pied de moteur
Soportes del motor
Staffe supporto

A 15

Anschlußgehäuse
Intermediate housing
Bride raccord
Caja de conexión
Flangiatura

Tafel Nr.
Tabl.No.
Tavola N.

17

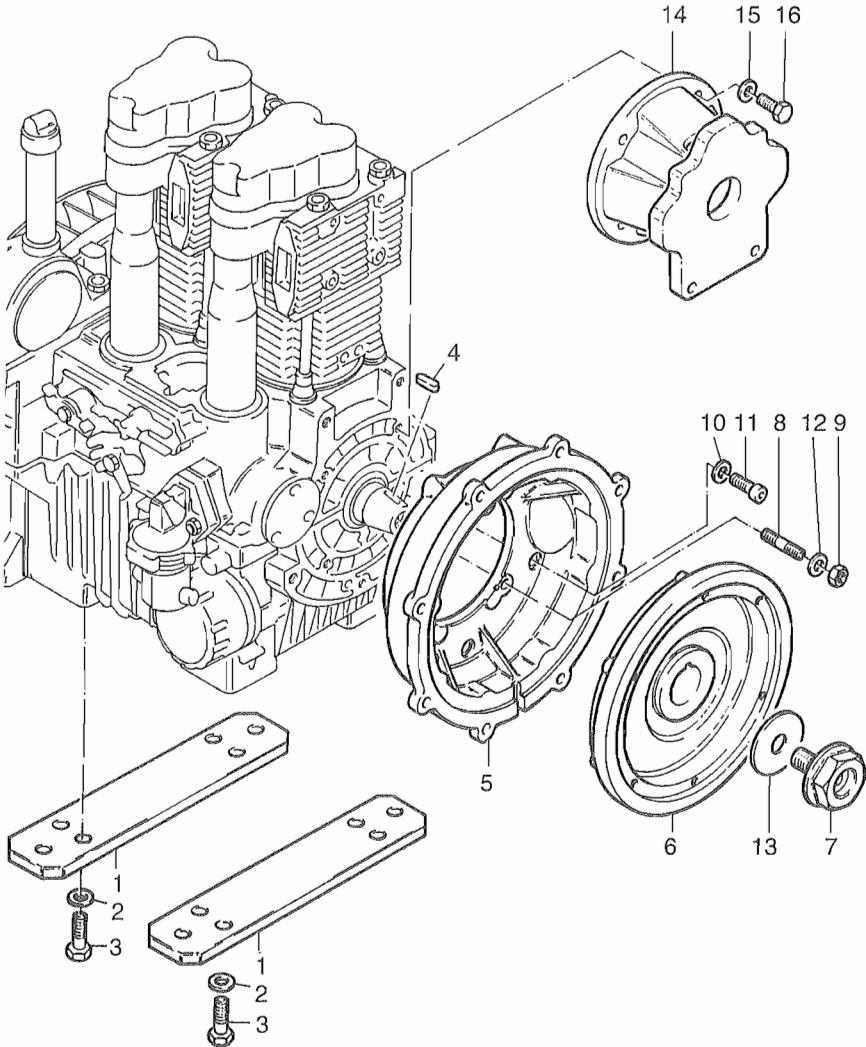

Fig.-No.	HATZ Ident-No.	Stück Qty.	P / W d / D	Bemerkungen Notes
		2 G 30	2 G 40	
1	03920000	2	2	
2	50135600	8	8	10 DIN 128 A3C
3	50327600	8	8	M 10 x 35 DIN 933-8.8 A3C
4	50011200	1	1	6 x 6 x 25 DIN 6885
5	50295400	1	1	SAE 5
6	50295500	1	1	
7	50295600	1	1	M 18 x 1,5
8	50040400	4	4	M 10 x 25 DIN 835-5.6
9	50145800	4	4	M 10 DIN 934-8 A3C
10	50145900	5	5	10,5 DIN 125-St A3C
11	50327800	5	5	M 10 x 35 DIN 912-8.8 A3C
12	50145900	4	4	10,5 DIN 125-St A3C
13	50304700	1	1	21 x 70 x 1,5
14	03929200	1	1	Ø 46 mm
15	50145900	4	4	10,5 DIN 125-St A3C
16	50136400	4	4	M 10 x 25 DIN 933-8.8 A3C

A 07

Zusatzölkühlung
 Add. oil-cooling system
 Refroid. d'huile sup.
 Refrig. p. aceite sup.
 Sistema addizionale di raffreddamento olio

Tafel Nr.
 Tabl.No.
 Tavola N.

18

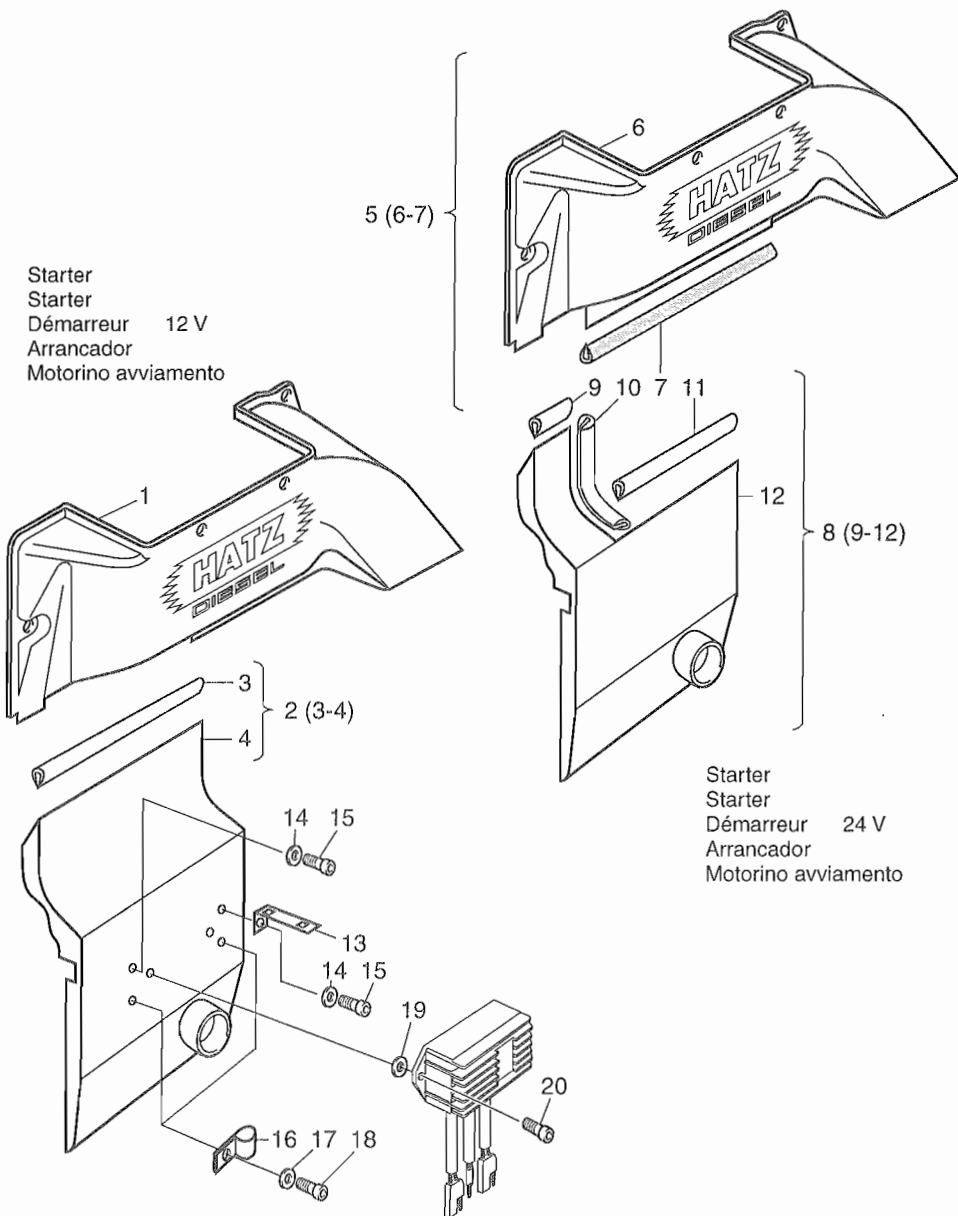

Fig.-No.	HATZ Ident-No.	Stück Qty.	P / W d / D	Bemerkungen Notes
		2 G 30	2 G 40	
1	03995900	1	1	
2	01437600	1	1	
3	03999900	1	1	200 mm
4	-----	-	-	
5	01437500	1	1	
6	-----	-	-	
7	05007000	1	1	190 mm
8	01440000	1	1	
9	05007300	1	1	48 mm
10	05007200	1	1	115 mm
11	05007100	1	1	160 mm
12	-----	-	-	
13	05006700	1	1	
14	50144500	2	2	6,4 DIN 125-St A3C
15	50177100	2	2	M 6 x 16 DIN 933-8.8 A3C
16	50158400	2	2	14 / 15
17	50144500	2	2	6,4 DIN 125-St A3C
18	50170700	2	2	M 6 x 16 DIN 912-8.8 A3C
19	50148100	2	2	8,4 DIN 125 St A3C
20	50165400	2	2	M 8 x 16 DIN 912-8.8

A 11

Kraftstoffabsperrentil
Shut-off valve
Soupape de arret
Valvula cierre
Valvula p. chiudere il carb.

Hubmagnet zur Motorabstellung
Lifting magnet engine stop
Electro aimant moteur stop
Elevador magnet motor stop
Elettrostop

Tafel Nr.
Tabl. No.
Tavola N.

19

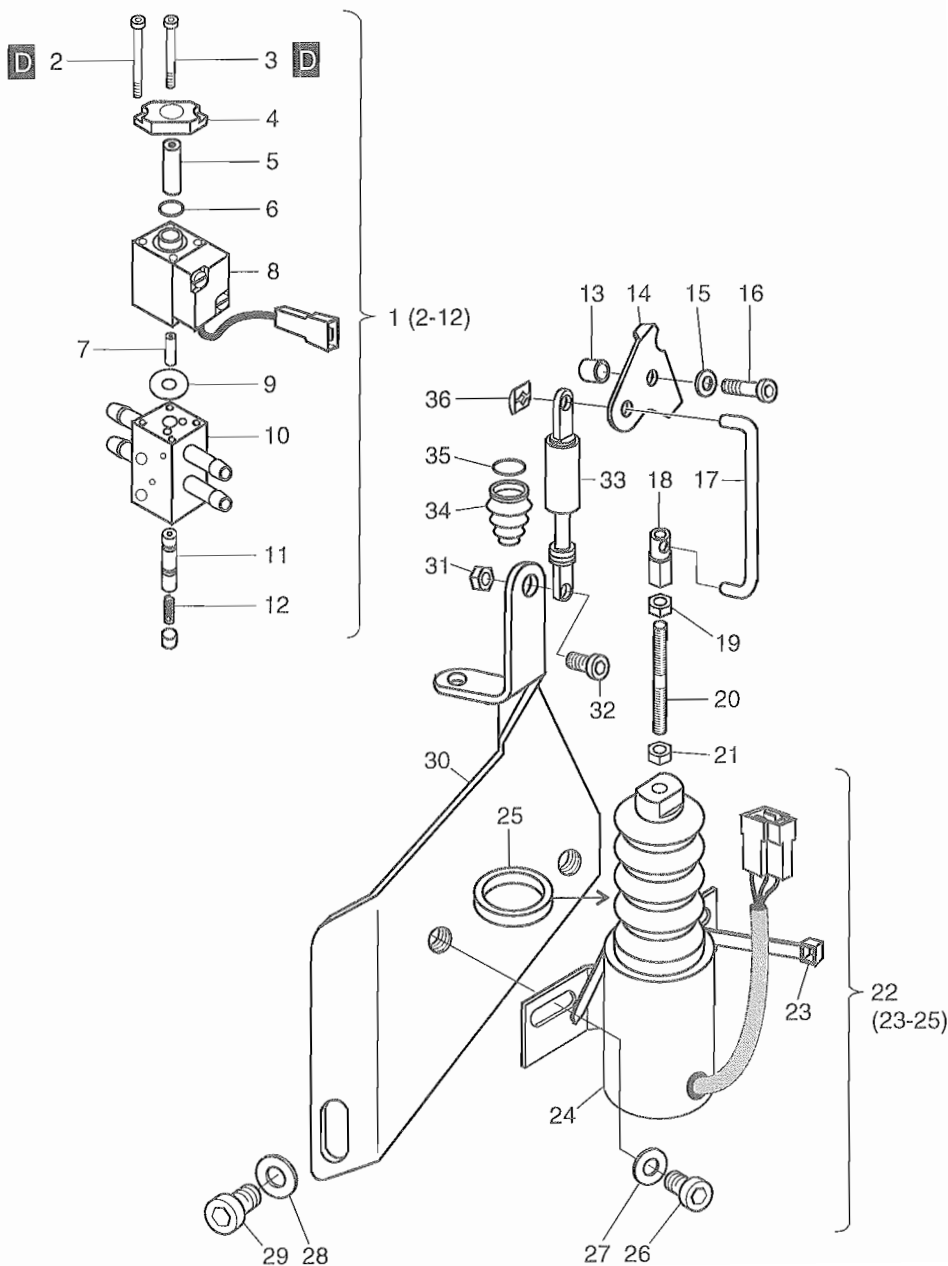

Fig.-No.	HATZ Ident-No.	Stück Qty.	P / W d / D	Bemerkungen Notes
		2 G 30	2 G 40	
1	01178100	1	1	12 V
1	01195400	1	1	24 V
2	50354700	2	2	M 4 x 45 DIN 933-8.8 C4P
3	50269900	2	2	M 4 x 35 DIN 912-8.8 A3C
4	03955000	1	1	
5	03956100	1	1	
6	50275000	1	1	14 x 1,78
7	-----	-	-	
8	03954802	1	1	12 V, 14 W
8	03967602	1	1	24 V, 14 W
9	03959300	1	1	
10	-----	-	-	
11	-----	-	-	
12	-----	-	-	
13	03125800	1	1	7 x 12 x 10
14	05063900	1	1	
15	50170900	1	1	6 DIN 128 A3C
16	50170800	1	1	M6 x 25 DIN 912-8.8 A3C
17	05063800	1	1	
18	05064010	1	1	
19	50446700	1	1	M6 DIN 934-8 A3C „links“
20	05094600	1	1	M6
21	50144400	1	1	M6 DIN 934-8 A3C
22	01509010	1	1	12 V
22	01509110	1	1	24 V
23	50167400	1	1	4/360
24	-----	-	-	
25	05063700	1	1	
26	50149100	2	2	M6 x 12 DIN 912-8.8 A3C
27	50144500	2	2	6,4 DIN 125-St A3C
28	50135600	1	1	10 DIN 128-A3C
29	50290300	1	1	M 10 x 25 DIN 912-8.8 A3C
30	01516900	1	1	
31	50144400	1	1	DIN 934-8 A3C
32	50323800	1	1	M 6 x 16 DIN 6912-8.8
33	50431300	1	1	
34	50180400	1	1	V6 - 1008
35	50225501	1	1	14 x 3
36	50365600	2	2	

A 16

Wellenstummel, elast. Kupplung
Stubshaft, flexible coupling
Bout de arbre, accouplement elastic
Eje, acoplamiento elast.
Contralbero, giunto elastico

Tafel Nr.
Tabl. No.
Tavola N.

20

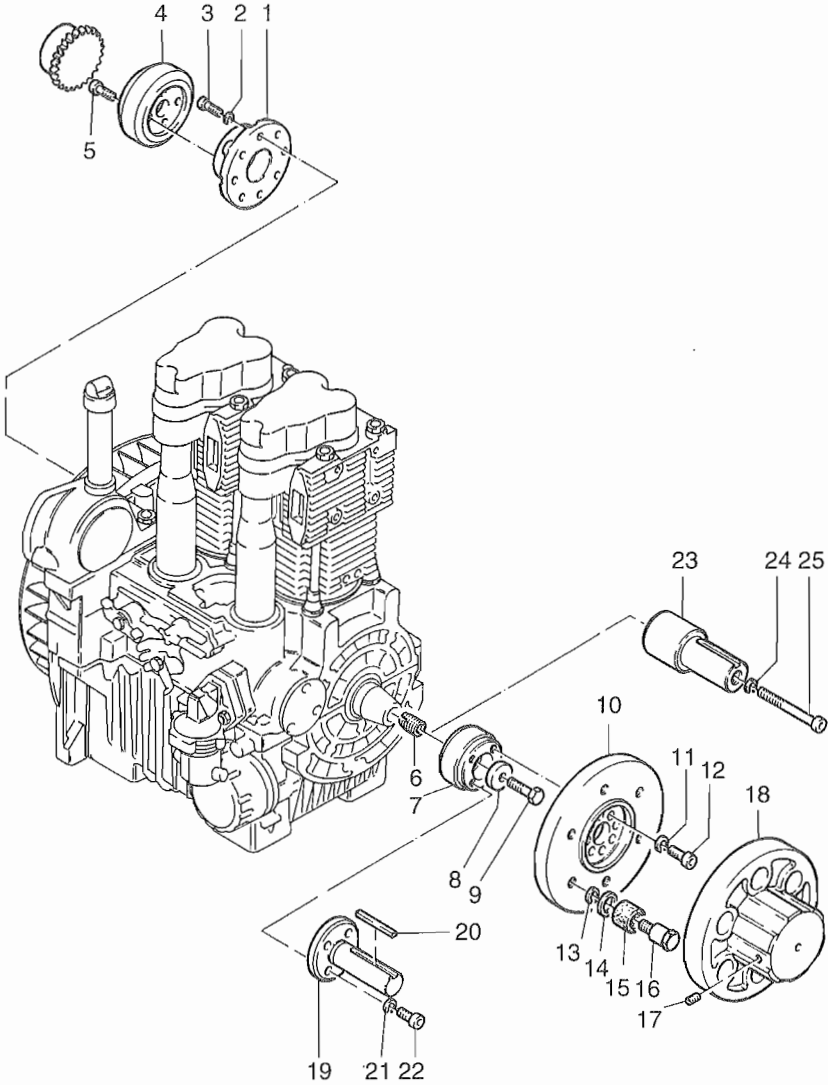

Fig.-No.	HATZ Ident-No.	Stück Qty.	P / W d / D	Bemerkungen Notes
		2 G 30	2 G 40	
1	03930900	1	1	Ø 70 mm
2	50208500	4	4	8 DIN 128 A3C
3	50171500	4	4	M 8 x 25 DIN 912-8.8 A3C
4	50345100	1	1	48 FLE - PA
5	50054000	4	4	M 10 x 25 DIN 6912-8.8
6	50333900	1	1	M 10 - M 18 x 1,5
7	03946500	1	1	
8	03928910	1	1	11 x 37,5 x 9
9	50029600	1	1	M 10 x 45 DIN 933-8.8 A3C
10	03115000	1	1	
11	50002900	4	4	10 DIN 128
12	50053800	4	4	M 10 x 25 DIN 912-8.8
13	50061600	6	6	12 DIN 7980
14	03079000	6	6	20,3 x 26,9 x 4
15	03151000	6	6	
16	03046900	6	6	
17	50004600	1	1	AM 8 x 16 DIN 916-45 H
18	03040500	1	1	12 H 7
19	03027300	1	1	30 x 110
20	50011700	1	1	A 8 x 7 x 63 DIN 6885
21	50002900	4	4	10 DIN 128
22	50053800	4	4	M 10 x 25 DIN 912-8.8
23	03933610	1	1	
24	50146000	1	1	10 DIN 7980 Zn
25	50120500	1	1	M 10 x 100 DIN 912-8.8

A 17

Kupplung dauerausrückbar
Clutch perm. disconn.
Embrayage debr. continu
Embrague permanente
Frizione punto morto

Tafel Nr.
Tabl. No.
Tavola N.

21

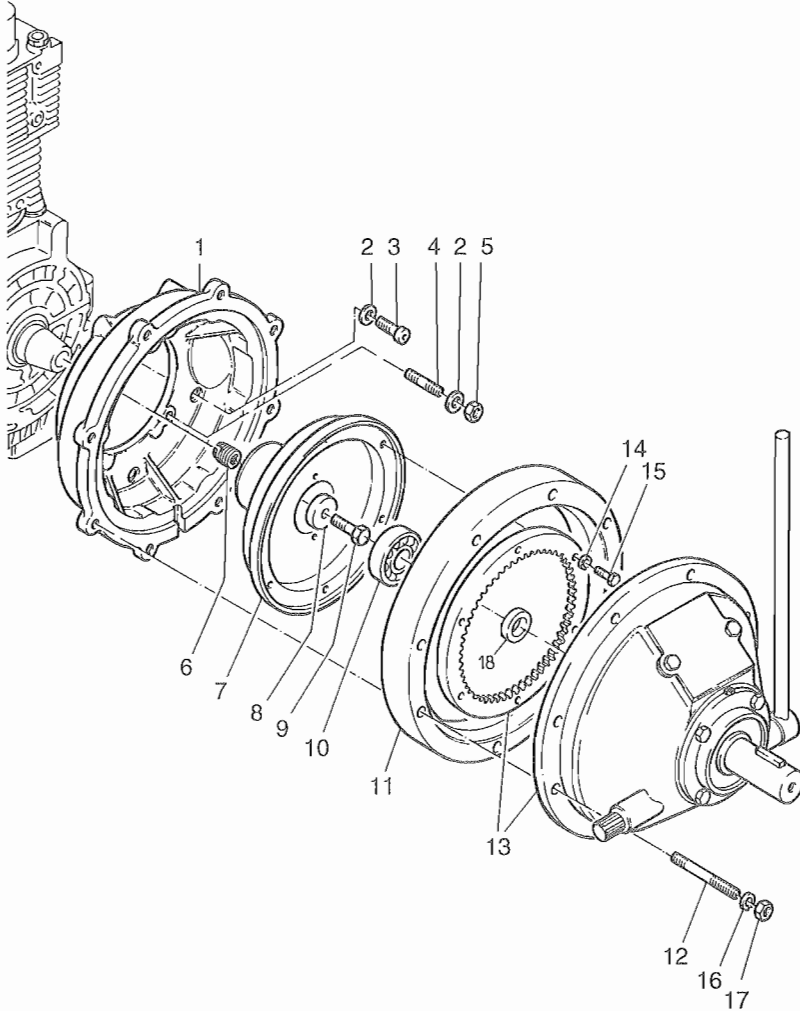

Fig.-No.	HATZ Ident-No.	Stück Qty.	P / W d / D	Bemerkungen Notes
		2 G 30	2 G 40	
1	50295400	1	1	SAE 5
2	50295100	9	9	10,5 x 21
3	50327800	5	5	M 10 x 35 DIN 912-8.8 A3C
4	50294900	4	4	M 10 x 25
5	50145800	4	4	M 10 DIN 934-8 A3C
6	50333900	1	1	M 18 x 1,5
7	03947400	1	1	
8	03928910	1	1	11 x 37,5 x 9
9	50029600	1	1	M 10 x 45 DIN 933-8.8 A3C
10	50114200	1	1	6305 2RS DIN 625
11	03680300	1	1	
12	50145300	8	8	M 10 x 65 DIN 835-8.8 A3C
13	50349300	1	1	BD 110/15
14	50002800	6	6	8 DIN 128
15	50027300	6	6	M 8 x 30 DIN 933-8.8
16	50135600	8	8	10 DIN 128 A3C
17	50145800	8	8	M 10 DIN 934-8 A3C
18	05019900	1	1	25,2 x 35 x 8

A 18

Anbauteile Hydraulikpumpe
Mount. parts hydr. pump
Pièces mont.-pompe hydr.
Piezas mont. bpmba hidraulico
Particolari per montag. pompa idraulica

Tafel Nr.
Tabl. No.
Tavola N.

22

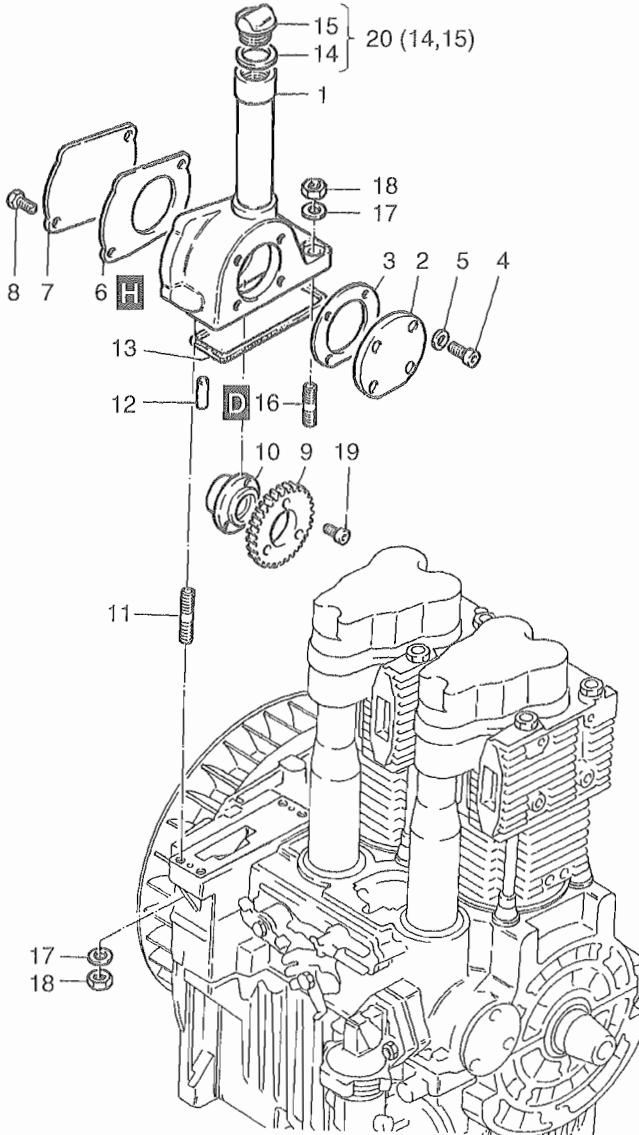

Fig.-No.	HATZ Ident-No.	Stück Qty.	P / W d / D	Bemerkungen Notes
		2 G 30	2 G 40 H	
		↓		
1	01125602	1	1	
2	03908800	1	1	
3	03908900	1	1	0,5 mm
4	50323800	4	4	M 6 x 16 DIN 6912-8.8 A3C
5	50000800	4	4	A 6,5 x 9,5 DIN 7603-Cu
6	03916100	2	2	0,5 mm
7	03908700	1	1	
8	50092200	2	2	M 10 x 16 DIN 933-8.8 A3C
9	03914310	1	1	
10	03908600	1	1	
11	50231900	2	2	M 8 x 25 DIN 835-8.8 A3C
12	50290500	2	2	6 m 6 x 14 DIN 7-9 S20K
13	50323500	1	1	D1
14	50153800	1	1	D1 23 x 3
15	-----	-	-	
16	50128100	2	2	M 8 x 30 DIN 835-10.9 A3C
17	03788800	4	4	8,4 x 15 x 2
18	50335300	4	4	M 8 A3C SW 12
19	50050700	3	3	M 6 x 16 DIN 912-8.8
20	00632101	1	1	W1

