

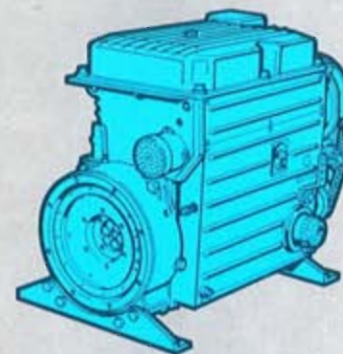

MOTORENFABRIK HATZ GMBH & CO KG · D-8399 RUHSTORF a. d. ROTT
TEL. (0 85 31) 30 21 · TELEX 5 7260

Ersatzteil-Liste
Spare parts list
Liste des pièces de rechange
Lista de recambios



3L30S
3L30Z

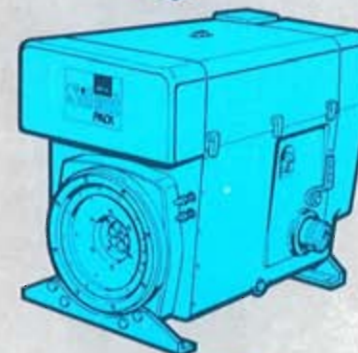

3L30C

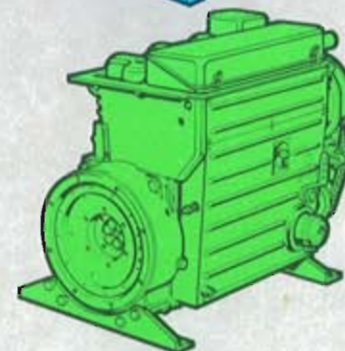

3M40

WICHTIG – Bitte Daten eintragen
IMPORTANT – Compléter les données

IMPORTANTE – Favor completar datos
IMPORTANT – Please enter data

1.

Bitte hier **Type**, **Motornummer** und **Drehzahl** (siehe Motor-Typenschild) eintragen.

Enter here **type engine no.** and **rpm.** (see engine type-plate).

Indiquer ici le **type**, **N° de moteur** et **régime** (voir plaque signalétique).

Insertar aquí **tipo- N° motor** y **r.p.m.** (vea placa del motor).



2.

Bitte **Ersatzteillistennummer** (siehe Titelseite) gemäß Type ankreuzen, z. B. Typ 3 L 30:

3 L 30.19

Mark **spare parts list no.** (see title-page) acc. to type, e.g. for type 3 L 30:

3 L 30.19

Cocher le **N° de liste de pièces de rechange** (voir: couverture) selon type, par ex. 3 L 30:

3 L 30.19

Marcar **N° lista de recambios** (ver: frontispició) de acuerdo aipo, ejemplo tipo 3 L 30:

3 L 30.19

Ersatzteilliste Nr.

Spare parts list no.

Liste de pièces de rechange no.

Lista de recambios no.

3 L 30.19 3 M 40.13

3.

Bitte tragen Sie hier die **Anschrift** Ihrer nächsten HATZ-Servicestelle ein.

Insert here **address** of your next HATZ Service station.

Indiquer ici l'**adresse** de votre stationservice HATZ la plus proche.

Insertar aquí **dirección** de servicio HATZ más cercano.

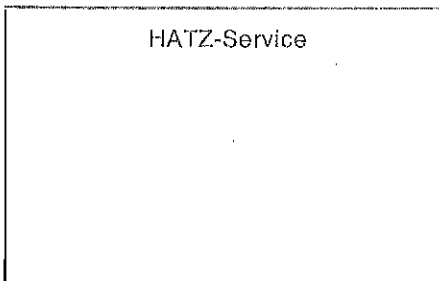
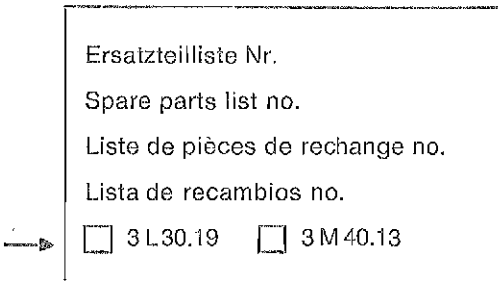

MOTORENFABRIK HATZ
GmbH & Co. KG
D - 8399 RUHSTORF a. d. ROTT
Federal Republic of Germany
☎ (0 85 31) 30 21 — Telex 5 7260

Angaben bei Ersatzteilbestellungen:

Zur richtigen und schnellen Belieferung mit Ersatzteilen sind folgende Angaben erforderlich:

1. **Type, Motornummer und Drehzahl** des Motors, für den das Ersatzteil benötigt wird: siehe Angaben auf Seite 1, Feld 1.
2. **Nummer der Ersatzteilliste**, aus der die Bestellnummer herausgelesen wurde: siehe Seite 1, Feld 2.
3. **Stückzahl und Bestell-Nr.** des gewünschten Ersatzteils.
4. Gewünschte **Versandart**, z. B. Post, Luftfracht, Express.
5. Genaue **Versandadresse**, wenn erforderlich mit Post- u. Bahnstation.

Bestellbeispiel:

Für Motortype: 3 L 30 S - 151 e
Motornummer: 521985005900
min⁻¹: 2500/150

aus Ersatzteil-Liste 3 L30.19
folgende Teile:

Stück	Bestell-Nr.
2	500 526 00
8	500 009 00

per Postexpress an . . .

Die Ersatzteilbestellung richten Sie bitte an:

— die nächste HATZ-Service-stelle, Anschrift siehe Seite 1, Feld 3 oder separates Servicestellenverzeichnis

— oder an die

Motorenfabrik Hatz GmbH & Co. KG
D - 8399 Ruhstorf a. d. Rott
Federal Republic of Germany
☎ (085 31) 30 21 — Telex 5 7260

Particulars for spare parts orders:

The following information is needed to ensure correct and prompt supply of spare parts:

1. **Engine type, engine number and r.p.m.** of the engine for which you need the spare part.
See particulars on page 1, field 1.
2. **Number of spare parts list** from which you took the ordering no., see page 1, field 2.
3. **Quantity and ordering no.** of requested spare part.
4. Requested **mode of dispatch**, e. g. surface / airmail, airfreight, express.
5. Exact **shipping address**, if necessary indicate local post office and/or railway station.

Example for your order:

For engine type: 3 L 30 S - 151 e
Engine number: 521985005900
R. p. m.: 2500/150

Spare parts list no. 3 L30.19

The following parts:

Qty.	ordering-no.
2	500 526 00
8	500 009 00

to be mailed, express, to . . .

Please address your spare parts order to:

— your nearest HATZ service station, address see page 1, field 3 or separate HATZ-service-list.

— or to

Motorenfabrik Hatz GmbH & Co. KG
D - 8399 Ruhstorf a. d. Rott
Federal Republic of Germany
☎ (085 31) 30 21 — Telex 5 7260

01

	Bestell-Nr. Ordering No. No. référence No. de pedido	Stück Quantity Quantites Cantidades			Hinweis Hints Indications Indicaciones
		3 L.30 S/Z	3 L.30 C	3 M.40	
1	009 919 00 P1	1	1	—	Dichtungssatz f. 1 Zylinderkopf Gasket set for cyl. head Jeu de joint p. 1 culasse Juego de juntas para 1 culata
1	009 922 00 P1	—	—	1	
2	009 337 01	1	1	—	Dichtungssatz o. Wellendichtring Gasket set without oil seals Jeu de joints sans ann. etanch. Juego de juntas sin anillo de reten
2	009 913 01	—	—	1	
3	009 622 00	1	1	—	Wartungssatz für 1000 h 1000 hours maintenance kit Kit d'entretien 1000 heures Juego de piezas para mantenimiento 1000 horas
3	009 915 01	—	—	1	
4	009 672 02	1	1	—	Pannensatz Emergency kit Kit de secours Juego para averias
4	009 872 01	—	—	1	
5	009 383 01	—	—	1	Zubehörsatz Accessories kit Sort. accessoires Juego de accesorios
5	009 383 00	1	1	—	

Wartungssatz: Einzelteile und Anzahl siehe W... neben Ident-Nr.

Pannensatz: Einzelteile und Anzahl siehe P... neben Ident-Nr.

Maintenance kit: Component parts and quantity see W... besides the Ident-No.

Emergency kit: Component parts and quantity see P... besides the Ident-No.

Kit d'entretien: Pièces composantes et quantité voir W... à côté du No. ident

Kit de secours: Pièces composantes et quantité voir P... à côté du No. ident

Juego de piezas para servicio: Piezas unitarias y cantidad ver W... lado No. ident

Juego para averias: Piezas unitarias y cantidad ver P... lado No. ident

Tafel Nr.
Table No.
Tableau No.
Tabla No.

02

Kurbelgehäuse
Crankcase
Carter moteur
Caja cigueñal

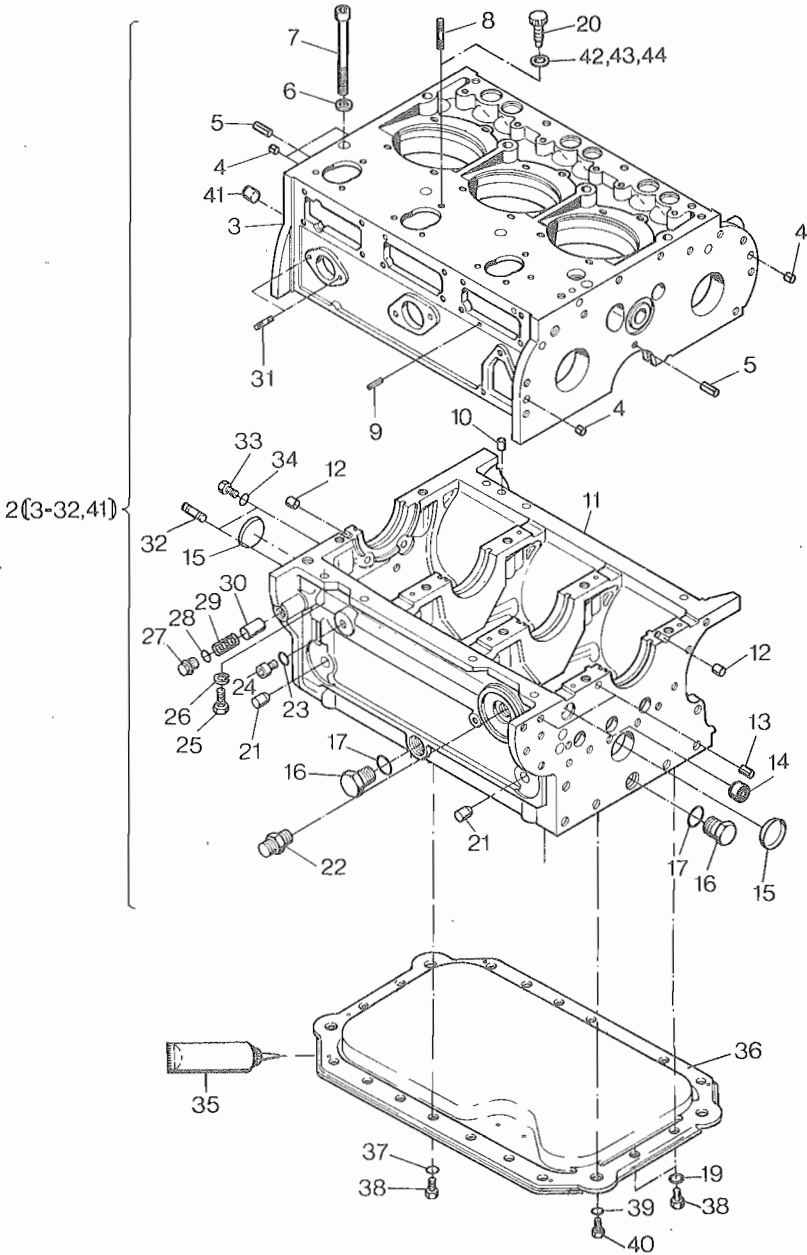

Données à indiquer lors de vos commandes de pièces détachées:

Pour nous permettre de livrer vos pièces rapidement et correctement, nous avons besoin des données suivantes:

1. **Type, No. et régime du moteur** pour lequel vous avez besoin de pièces: voir données page 1, carré 1.
2. **No de la liste de pièces de rechange** dans laquelle figure le No. de commande: voir page 1, carré 2.
3. **Quantité et No. de commande** de la pièce souhaitée.
4. **Mode d'expédition** souhaité: par ex. par poste, frêt aérien, exprès.
5. **Adresse exacte de destination** et, lorsque ceci est nécessaire, le nom de la poste ou de la gare, ou aéroport.

Exemple:

Pour type de moteur: 3 L 30 S - 151 e
No. moteur: 521985005900
Régime: 2500/150

Liste de pièces de rechange: 3 L 30.19
Les pièces suivantes:

Qté	No. commande
2	500 526 00
8	500 009 00

par poste exprès à . . .

Les commandes de pièces détachées sont à adresser à:

— votre station-service HATZ la plus proche, voir adresse page 1, carré 3 ou liste de service séparée.

— ou

Motorenfabrik Hatz GmbH & Co. KG
D - 8399 Ruhstorf a. d. Rott
République Fédérale d'Allemagne
☎ (0 85 31) 30 21 — Télex 5 7260

Datos para pedidos de recambios:

Para recibir sus recambios en forma rápida y correcta necesitamos las siguientes informaciones:

1. **Tipo, número del motor y revoluciones:**
ver detalles en página 1, posición 1.
2. **Número de la lista de recambios** de la cual se ha obtenido el número de pedido: ver página 1, posición 2.
3. **Cantidad y número de pedido del recambio deseado.**
4. Tipo de **despacho deseado:** por ej. correo, flete aéreo, expreso etc.
5. **Dirección exacta**, si necesario indicar la oficina de correo, la estación ferrocarril o aeropuerto.

Ejemplo de pedido:

Número de motor: 3 L 30 S - 151 e
R. P. M.: 521985005900
Para motor tipo: 2500/150

De la liste de recambios: 3 L 30.19
Sigüientes recambios:

Cantidad	Número de pedido
2	500 526 00
8	500 009 00

Por correo expreso a

El pedido de recambios favor dirigirlo a:

— Al servicio HATZ más cercano, dirección verla en página 1, posición 3 or en el índice separado de direcciones de servicio.

— Alternativa a:

Motorenfabrik Hatz GmbH & Co. KG
D - 8399 Ruhstorf a. d. Rott
República Federal de Alemania
☎ (0 85 31) 30 21 — Telex 5 7260

	Inhaltsverzeichnis:	Index:	
M . . .	Grundmotor	Basic engine	
00, 34	Ersatzteilsätze, Zubehör	Spare part kits, accessories	01
01	Kurbelgehäuse	Crankcase	02+03
01	Massenausgleich	Compensation of masses	04
02, 03	Kurbelwelle	Crankshaft	05
04	Nockenw., Regler, Spritzversteller	Camshaft, governor, timer	06
32	Drehzahlverstellung	Speed control	07
05, 06	Pleuelstange, Kolben, Zylinder	Conrod, piston, cylinder	08
07	Zylinderkopf	Cylinder head	09
09, 10	Stoßstange, Ölpumpe	Pushrod, oil pump	10
11, 12	Steuerdeckel, Startfüllung	Timing cover, extra fuel device	11
13	Gebälse	Blower	12
14	Einspritzausrüstung	Injection equipment	13
16 - 20	Riemenscheibe, Schwungrad, Hydr. Abstellvorrichtung	Pulley, flywheel, hydr. belt tensioner	14
22, 27	Luftfilter, Luftansaugrohr	Air filter, air intake manifold	15
26	Luftführung	Air ducting	16
26	Luftführung S/Z	Air ducting S/Z	17
26	Luftführung	Air ducting	18
35	Kapsel C	Capsule C	19+21
35	Kapsel - Abluftschacht	Capsule - air ducting	20
A . . .	Zusatzausrüstung	Equipements	
01	Kraftstoff	Fuel	22
03	Auspuff S/Z	Exhaust S/Z	23
03	Auspuff C	Exhaust C	24
05	Starter, Generator	Starter, alternator	25
05, 10	Armaturen	Electric equipment	26
06, 15	Motorfüße, Anschlußgehäuse	Engine bracket, intermediate housing	27
12	Keilriemenschutz	V-belt guard	
07	Ölkühler	Oil cooler	28
18	Steuerdeckel für Hydraulikp.	Timing cover hydr.	29
	Serien-Nr.-Änderungen	Serial-code modification list	Seite/Page
			98

Sommaire:

Indice:

M . . .	Moteur de base	Motor de base	
00, 34	Jeux de pièces de rechange, accessoires	Juegos de piezas de recambios, accesorios	01
01	Carter moteur	Caja cigueñal	02+03
01	Equilibrage des masses	Compensación de las masas	04
02, 03	Vilebrequin	Cigueñal	05
04	Arbre à cames, regulateur, variateur d'avance	Arbol de levas, regulador, variador de avance	06
32	Reglage regime	Adjuste de revoluciones	07
05, 06	Bielle, piston, cylindre	Biela, émbolo, cilindro	08
07	Culasse	Culata	09
09, 10	Tige de culbuteur, pompe à huile	Varilla de balancín, bomba de aceite	10
11, 12	Couvercle distribut, surcharge	Tapa de mando, sobre alimentación - arranque	11
13	Soufflerie	Ventilador	12
14	Equipement d'injection	Equipo de inyección	13
16 - 20	Pouille, volant, tendeur hydr.	Polea, volante, tensor hidráulico	14
22, 27	Filtre à air, collecteur d'admission	Filtro de aire, tubo de conducción	15
26	Carter ventilation	Conducción de aire	16
26	Carter ventilation S/Z	Conducción de aire S/Z	17
26	Carter ventilation	Conducción de aire	18
35	Capsule C	Cápsula C	19+21
35	Capsule - carter ventilation	Capsula - chapa de aire	20
A . . .	Accessoires	Equipos	
01	Carburant	Combustible	22
03	Echappement S/Z	Escape S/Z	23
03	Echappement C	Escape C	24
05	Demarreur, alternateur	Arrancador, alternador	25
05, 10	Equipement électrique	Equipo eléctrico	26
06, 15	Pieds moteur, bride raccord, protecteur courroie	Soportes del motor, caja de conexión, proteccion corea	27
07	Radiateur d'huile	Radiador de aceite	28
18	Couvercle p. hydr.	Tapa de mando p. hidraulico	29

Tafel Nr.
Table No.
Tableau No.
Tabla No.

01

Ersatzteilsätze, Zubehör
Spare part kits, accessories
Jeux de pièces de rechange, accessoires
Juegos de pieza de recambios, accesorios

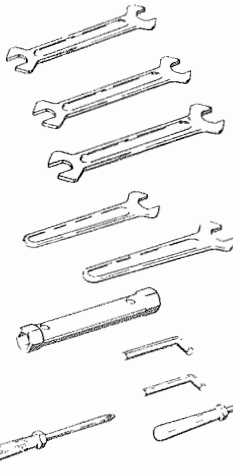
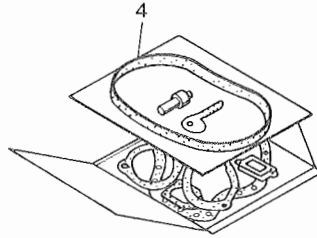
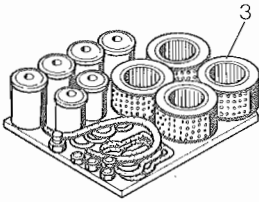
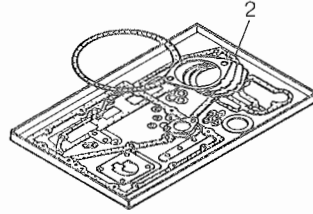
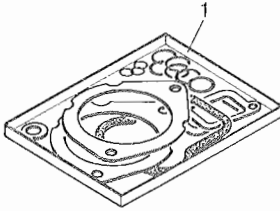

5

	Bestell-Nr. Ordering No. No. référence No. de pedido	Stück Quantity Quantites Cantidades			Hinweise Hints Indications Indicaciones	
		3 L 30 S	3 M 40	3 L 30 C/Z		
1	—	—	—	—		
2	009 539 01	1	—	1		
2	009 918 01	—	1	—		
3	—	—	—	—		
4	501 400 00	4	4	4	8 x 8	DIN 7346
5	501 305 00	2	2	2	5 x 24	DIN 1481
6	034 693 00	8	8	8		
7	501 259 00	8	8	8	M 12 x 1,5 x 190	DIN 912-10.9
8	501 122 00	8	8	8	M 8 x 18	DIN 939-10.9
9	501 305 00	1	1	1	5 x 24	DIN 1481
10	036 353 00	1	1	1	8 x 20	
11	—	—	—	—		
12	501 314 00	2	2	2	10m 6 x 14	DIN 7-St 50K
13	500 849 00	2	2	2	8 x 12	DIN 7346
14	501 302 00	1	1	1		
15	501 408 00	2	2	—	38	DIN 443
16	501 404 00 W1	2	2	2	AM 22 x 1,5	DIN 7604
17	500 016 00 W4	2	2	2	A 22 x 27	DIN 7603-Cu
18	038 636 00	—	1	—		
19	—	—	—	—		
20	038 622 00	1	—	1		
21	036 457 00	2	1	—	$n < 1500 \text{ min}^{-1}$	
22	400 654 00	1	1	1		
23	500 624 00	1	1	1	A 10 x 13,5	DIN 7603-Cu
24	500 623 00	1	1	1	M 10 x 1	DIN 908
25	500 268 00	12	12	12	M 8 x 20	DIN 933-8.8
26	500 028 00	12	12	12	8	DIN 128
27	032 493 00	1	1	1		
28	500 014 00	1	1	1	A 18 x 22	DIN 7603-Cu
29	036 399 00	1	1	1		
30	036 398 00	1	1	1		
31	501 392 00	2	2	2	M 6 x 16	DIN 939-8.8
32	502 408 00	—	—	2	M 8 x 12	DIN 938-8.8

Tafel Nr.
Table No.
Tableau No.
Tabla No.

02

Kurbelgehäuse
Crankcase
Carter moteur
Caja cigueñal

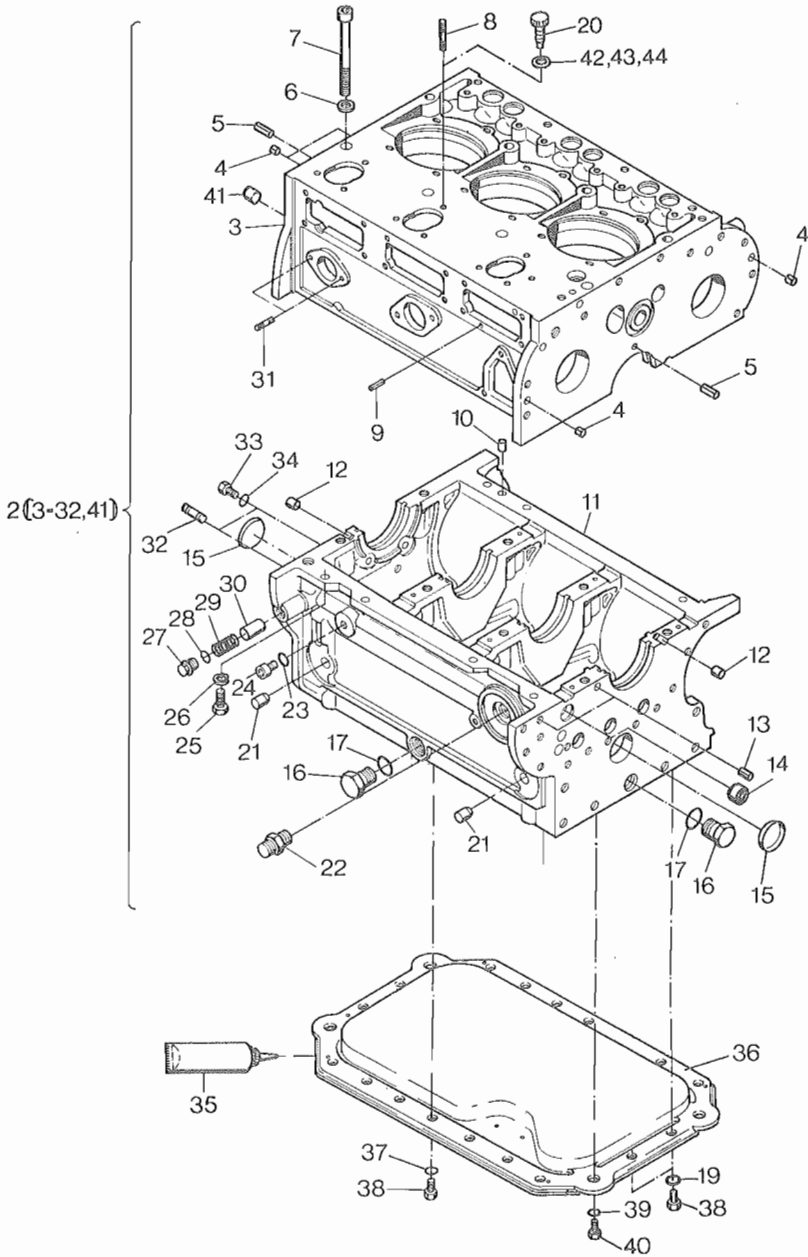

Bestell-Nr.
Ordering No.
No. référence
No. de pedido

Stück
Quantity
Quantities
Cantidades

Hinweise
Hints
Indications
Indicaciones

		3 L 30 S	3 M 40	3 L 30 C/Z		
33	500 265 00	2	2	1	M 8 x 10	DIN 933-8.8
34	501 629 00	2	2	1	A 8 x 14	DIN 7603-Cu
35	502 825 00	1	1	1		
36	037 527 01	1	1	1		
37	500 028 00	14	14	14	8	DIN 128
38	500 267 00	14	14	14	M 8 x 16	DIN 938-8.8
39	500 030 00	4	4	4	12	DIN 128
40	500 806 00	4	4	4	M 12 x 20	DIN 912-8.8
41	500 438 00	1	1	1	M 14 x 15	DIN 906
42	032 130 00	1	—	1	0,3 mm	
43	032 131 00	1	—	1	0,5 mm	
44	032 132 00	1	—	1	1,0 mm	
45	502 793 00	4	4	4	M 8 x 16	DIN 933-8.8

Tafel Nr.
Table No.
Tableau No.
Tabla No.

03

Kurbelgehäuse
Crankcase
Carter moteur
Caja cigueñal

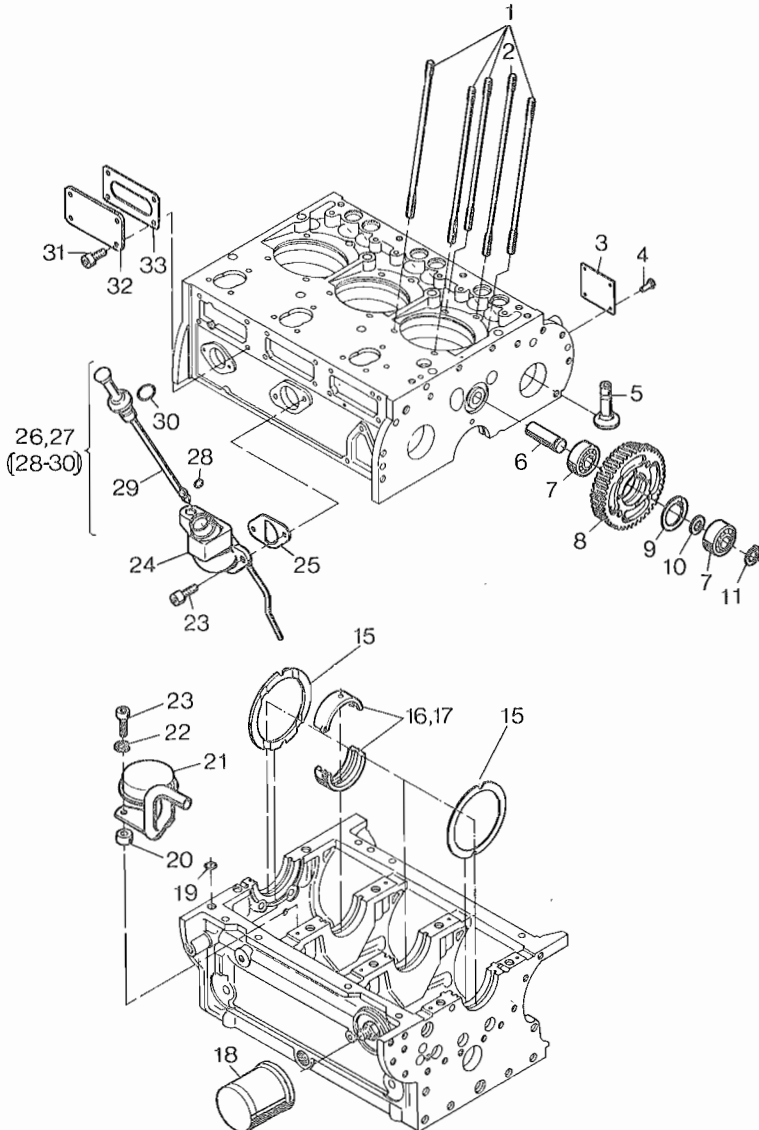

03

Bestell-Nr.
Ordering No.
No. référence
No. de pedidoStück
Quantity
Quantités
CantidadesHinweise
Hints
Indications
Indicaciones

3 L30 S/Z/C | 3 M40

1	035 663 00	12	—		
1	036 257 02	—	12		
2	035 664 00	3	—		
2	036 258 02	—	3		
3	036 396 00	1	1		
4	400 025 00	4	4		
5	035 545 01	6	6		
6	034 696 01	1	1		
7	500 137 00	2	2		
8	035 617 02	1	1		
9	500 217 00	1	1	47 x 1,75	DIN 472
10	034 623 00	1	1		
11	501 276 00	1	1	20 x 1,75	DIN 471
12	—	—	—		
13	—	—	—		
14	—	—	—		
15	034 633 00	2	2		
16	035 555 00	4	4	72 mm ϕ	
17	035 516 00	4	4	71,5 mm ϕ	
18	400 653 00 W4	1	1		
19	502 194 00	1	1		
20	034 670 00	2	2		
21	009 294 01	1	—		
21	010 906 00	—	1		
22	500 028 00	2	2	8	DIN 128
23	500 519 00	4	4	M 8 x 20	DIN 912-8.8
24	009 148 03	1	1		
25	501 290 00	1	1		
26	007 397 02	1	1	„A“	
27	009 308 00	1	1	„D“	
28	502 025 02	1	1		
29	—	—	—		
30	501 399 00	1	1		
31	501 289 00	8	8		
32	034 692 00	2	2		
33	035 513 00	2	2		

Tafel Nr.
Table No.
Tableau No.
Tabla No.

04

Massenausgleich
Compensation of masses
Equilibrage des masses
Compensación de las masas

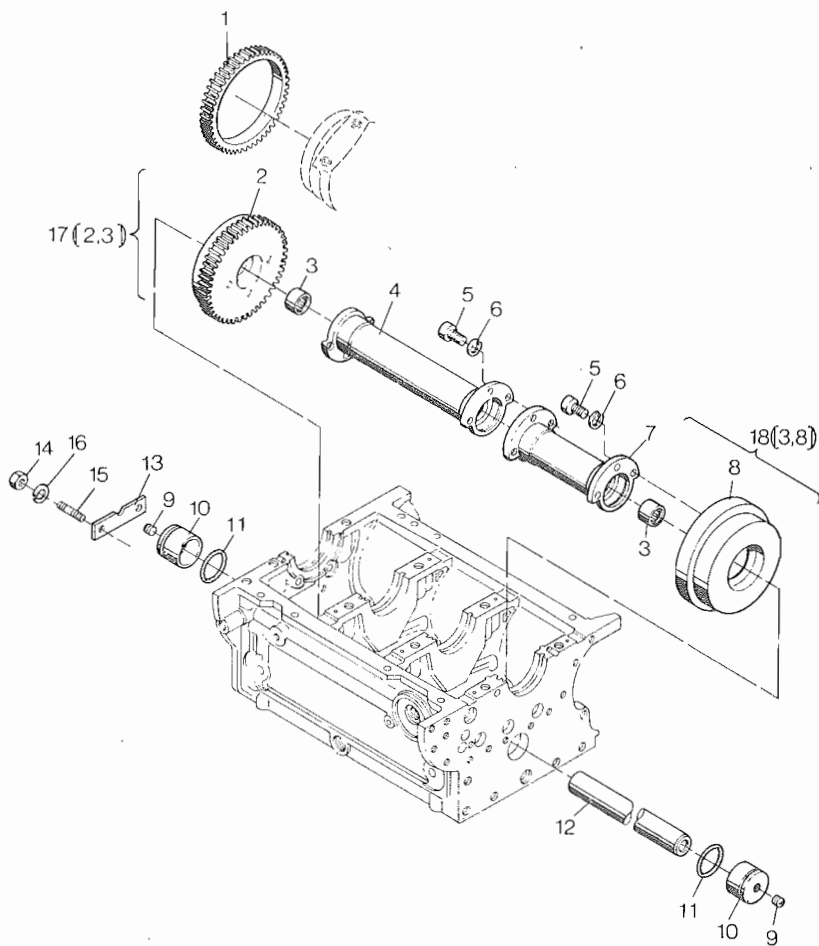

04

	Bestell-Nr. Ordering No. No. référence No. de pedido	Stück Quantity Quantities Cantidades			Hinweise Hints Indications Indicaciones	
		3 L 30 Z/C	3 L 30 S 3 M 40			
1	035 533 00	1	---			
2	---	---	---			
3	501 285 00	2	---			
4	035 530 00	1	---			
5	500 520 00	9	---		M 8 x 20	DIN 6912-8.8
6	501 282 00	9	---		8	DIN 127
7	035 683 00	1	---			
8	---	---	---			
9	500 436 00	2	---		M 10 x 1	DIN 906
10	034 634 00	2	---			
11	501 322 00	2	---			
12	035 900 00	1	---			
13	034 629 00	1	---			
14	500 229 00	2	---		M 8	DIN 934-8
15	502 408 00	2	---		M 8 x 12	DIN 938-8.8
16	500 028 00	2	---		8	DIN 128
17	009 020 00	1	---			
18	009 019 00	1	---			

Tafel Nr.
Table No.
Tableau No.
Tabla No.

05

Kurbelwelle
Crankshaft
Vilebrequin
Cigüeñal

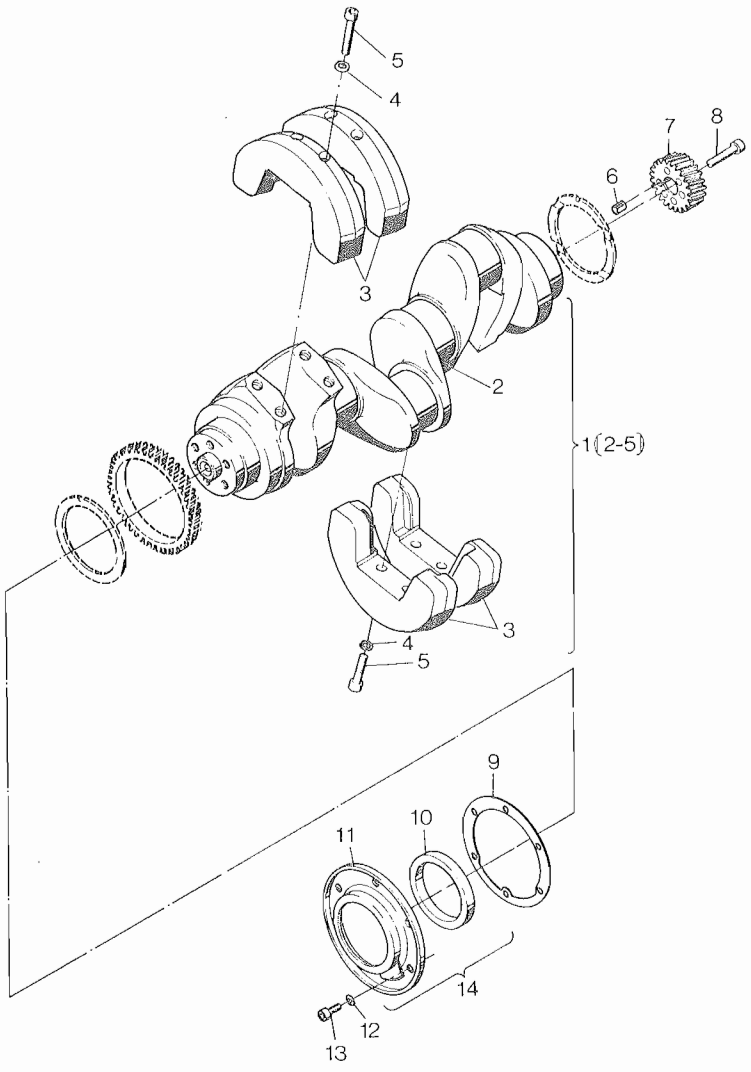

05

Bestell-Nr.
Ordering No.
No. référence
No. de pedido

Stück
Quantity
Quantités
Cantidades

Hinweise
Hints
Indications
Indicaciones

3 L30 S/Z/C | 3 L40 S/Z/C

1	009 023 00	1	—		
1	009 550 00	—	1		
2	—	—	—		
3	—	—	—		
4	500 029 00	8	8	10	DIN 128
5	501 328 00	8	8	M 10 x 40	DIN 912-10.9
6	501 280 00	1	1	11 x 10	DIN 7346 55 Si7
7	035 616 01	1	1		
8	501 279 00	6	6		
9	035 506 01	1	1		
10	501 303 00	1	—	70 x 90 x 10	
10	502 246 00	—	1	80 x 100 x 10	
11	—	—	—		
12	500 812 00	6	6	A 6	DIN 137
13	502 366 00	6	6	M 6 x 25	DIN 912-8.8
14	009 475 01	1	—		
14	009 575 00	—	1		

Tafel Nr.
Table No.
Tableau No.
Tabla No.

06

Nockenwelle, Regler, Spritzversteller
Camshaft, governor, timer
Arbre à cames, regulateur, variateur d'avance
Arbol de levas, regulador, variador de avance

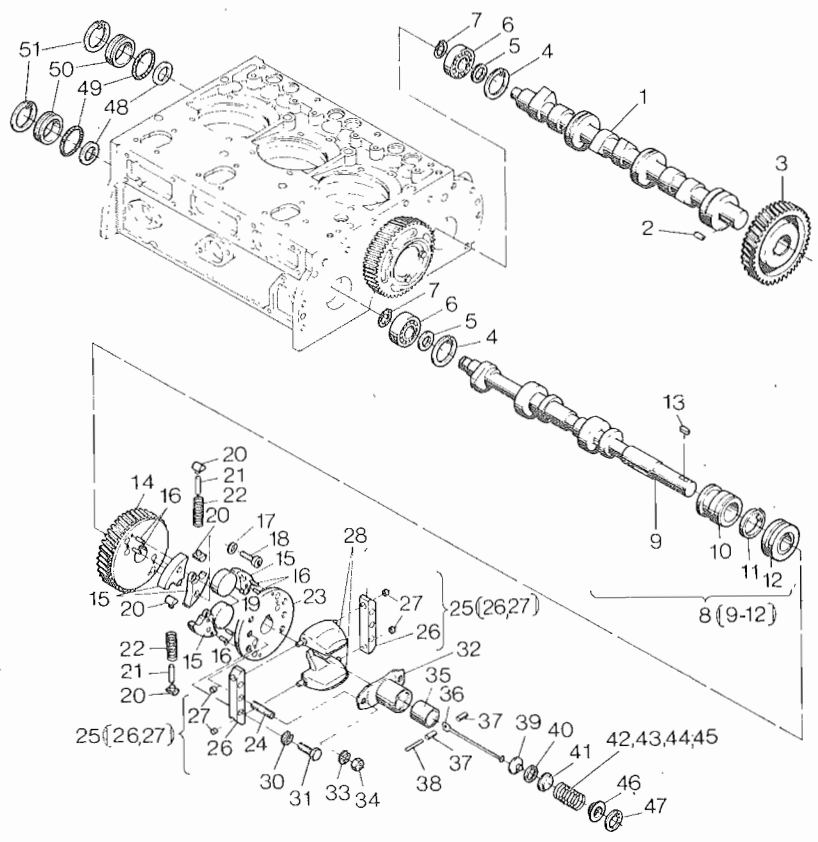

06

	Bestell-Nr. Ordering No. No. référence No. de pedido	Stück Quantity Quantites Cantidades	Hinweise Hints Indications Indicaciones
		3 L30 S/Z/C	
1	035 557 00	1	
2	500 113 00	1	A 8 x 7 x 22 DIN 6885
3	035 618 00	1	
4	500 217 00	2	47 x 1,75 DIN 472
5	501 329 00	0...3	20x28x0,1 DIN 988
6	500 137 00	2	
7	501 276 00	2	20 x 1,75 DIN 471
8	007 454 01	1	
9	—	—	
10	—	—	
11	035 765 01	1	
12	—	—	
13	501 316 00	1	A 6 x 6 x 20 DIN 6885 St6
14	035 619 00	1	
15	034 627 01	4	
16	500 579 00	8	4m 6 x 8 DIN 7-9 S20K
17	501 401 00	8	6 DIN 7980
18	501 432 00	8	M 6 x 18 DIN 6912-8.8
19	034 601 00	2	
20	034 645 00	4	
21	035 613 00	2	
22	035 614 00	2	
23	035 547 00	1	
24	501 315 00	2	M 8 x 30 DIN 938-8.8
25	007 458 00	2	
26	—	—	
27	035 721 00	4	
28	035 729 00	2	
29	—	—	
30	501 282 00	4	8 DIN 127
31	500 270 00	4	M 8 x 25 DIN 933-8.8
32	035 722 00	1	
33	501 282 00	2	8 DIN 127
34	500 229 00	2	M 8 DIN 934-8
35	035 716 00	1	
36	035 717 00	1	

Tafel Nr.
 Table No.
 Tableau No.
 Tabla No.

06

Nockenwelle, Regler, Spritzversteller
 Camshaft, governor, timer
 Arbre à cames, regulateur, variateur d'avance
 Arbol de levas, regulador, variador de avance

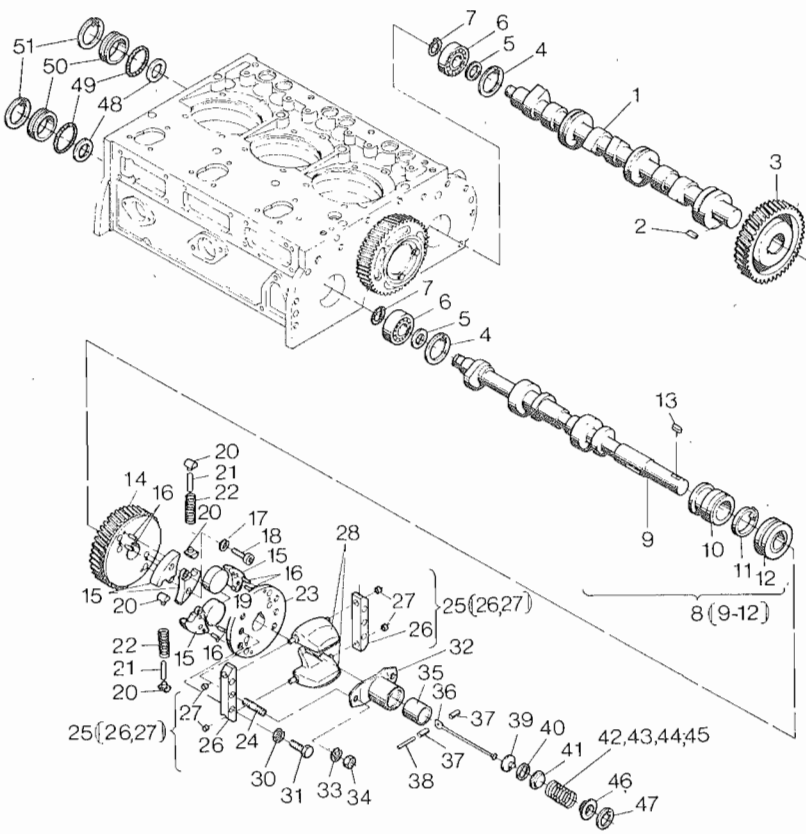

Bestell-Nr.
Ordering No.
No. référence
No. de pedido

Stück
Quantity
Quantités
Cantidades

Hinweise
Hints
Indications
Indicaciones

3 L30 S/Z/C

37	035 715 00	2		
38	035 764 00	1		
39	035 720 00	1		
40	501 380 00	1	B 26	DIN 7993
41	035 718 00	1		
42	036 014 01	1	2,5 mm ϕ	1500 min ⁻¹ Gen.
43	036 013 01	1	2,6 mm ϕ	1800 min ⁻¹ Gen.
44	036 012 01	1	3,0 mm ϕ	\leq 2300 min ⁻¹
45	035 744 01	1	3,2 mm ϕ	$>$ 2300 min ⁻¹
46	035 719 00	1		
47	500 210 00	1	32 x 1,2	DIN 472
48	502 773 00	0...1	37 x 47 x 0,5	DIN 988
48	501 327 00	0...3	37 x 47 x 0,1	DIN 988
49	501 307 00	2		
50	034 697 00	2		
51	500 217 00	2	47 x 1,75	DIN 472

Tafel Nr.
Table No.
Tableau No.
Tabla No.

06

Nockenwelle, Regler, Spritzversteller - 3 M 40
Camshaft, governor, timer
Arbre à cames, regulateur, variateur d'avance
Arbol de levas, regulador, variador de avance

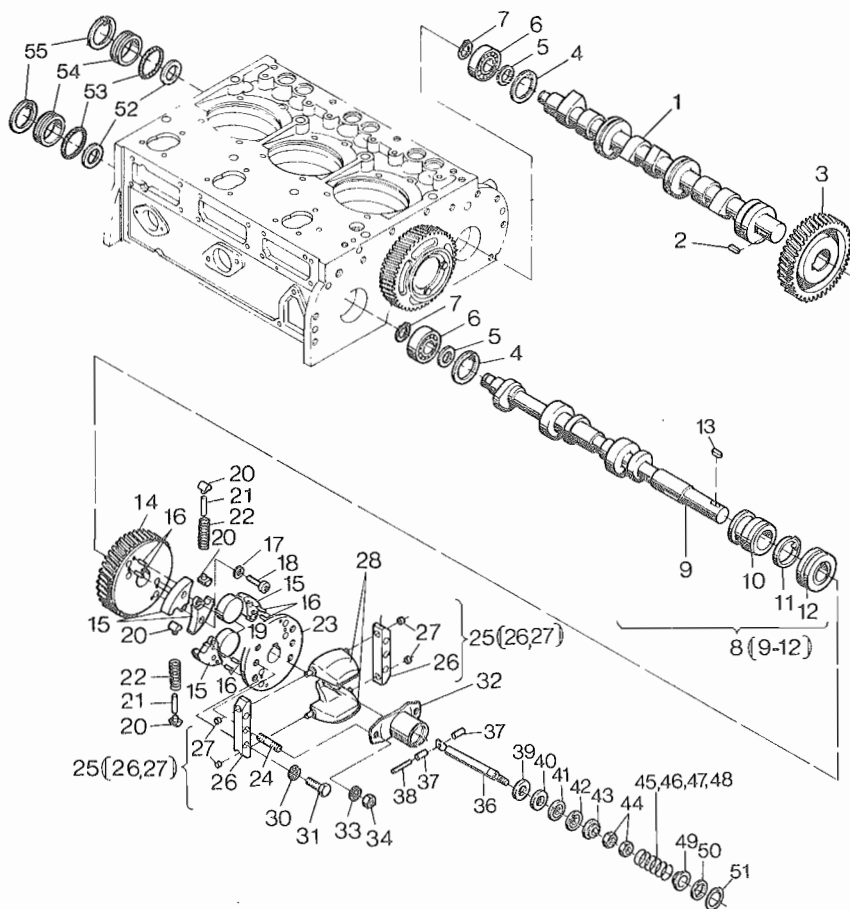

06

Bestell-Nr. Ordering No. No. référence No. de pedido	Stück Quantity Quantities Cantidades	Hinweise Hints Indications Indicaciones
---	---	--

3 M 40

1	035 557 00	1		
2	500 113 00	1	A 8 x 7 x 22	DIN 6885
3	035 618 00	1		
4	500 217 00	2	47 x 1,75	DIN 472
5	501 329 00	3	20 x 28 x 0,1	DIN 988
6	500 137 00	2		
7	501 276 00	2	20 x 1,75	DIN 471
8	012 121 00	1		
9	—	—		
10	—	—		
11	035 765 01	1		
12	—	—		
13	501 316 00	1	A 6 x 6 x20	DIN 6885 ST6
14	035 619 00	1		
15	034 627 01	4		
16	500 579 00	8	4 m 6 x 8	DIN 7-9S 20K
17	501 401 00	8	6	DIN 7980
18	501 432 00	8	M 6 x 18	DIN 6912-8.8
19	034 601 00	2		
20	034 645 00	4		
21	035 613 00	2		
22	035 614 00	2		
23	035 547 00	1		
24	501 315 00	2	M 8 x 30	DIN 938-8.8
25	007 458 00	2		
26	—	—		
27	035 721 00	4		
28	035 729 00	2		
30	501 282 00	4	8	DIN 127
31	500 270 00	4	M 8 x 25	DIN 933-8.8
32	037 731 00	1		
33	501 282 00	2	8	DIN 127
34	500 229 00	2		
35	—	—		
36	037 726 00	1		
37	037 725 00	2		

Tafel Nr.
Table No.
Tableau No.
Tabla No.

06

Nockenwelle, Regler, Spritzversteller - 3 M 40
Camshaft, governor, timer
Arbre à cames, regulateur, variateur d'avance
Arbol de levas, regulador, variador de avance

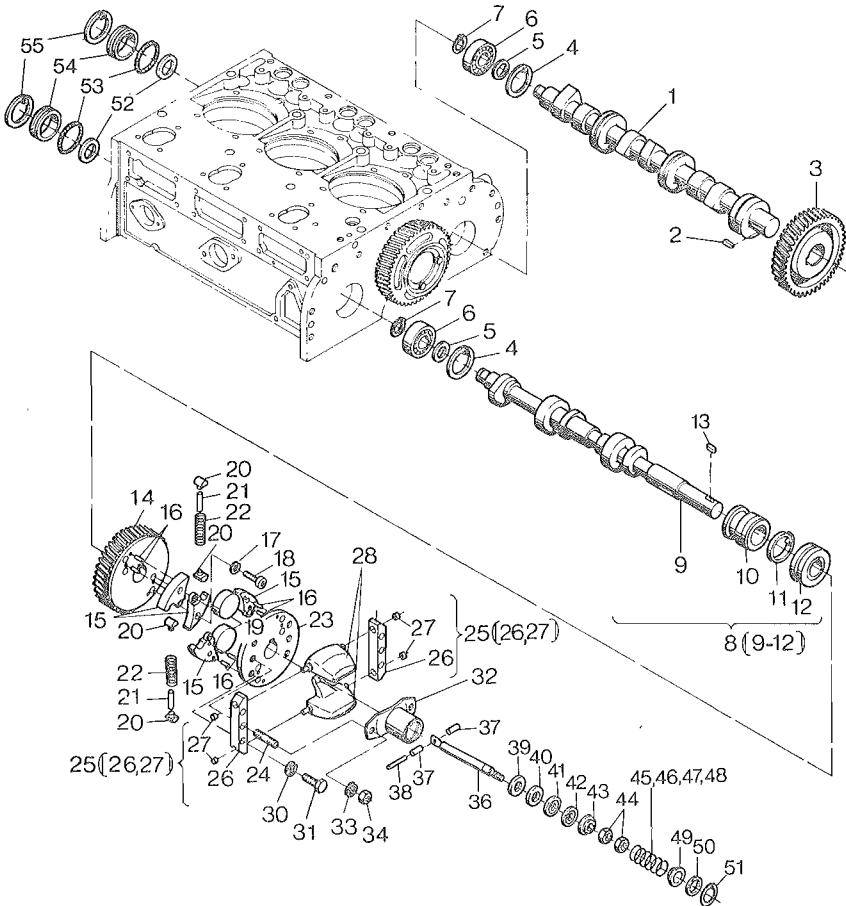

06

Bestell-Nr.
Ordering No.
No. référence
No. de pedido

Stück
Quantity
Quantites
Cantidades

Hinweise
Hints
Indications
Indicaciones

3 M 40

38	035 764 00	1	
39	037 727 00	1	
40	502 680 00	1	6 x 12 x 0,5 DIN 988
41	502 681 00	1	
42	502 682 00	1	
43	037 728 00	1	
44	500 227 00	2	M 6 DIN 934-8
45	038 670 00	1	2,3 mm ϕ 1500 min ⁻¹ Gen.
46	036 013 01	1	2,6 mm ϕ 1800 min ⁻¹ Gen.
47	036 012 01	1	3,0 mm ϕ \leq 2300
48	035 744 01	1	3,2 mm ϕ $>$ 2300
49	035 719 00	1	
50	037 729 00	1	n $>$ 1500 min ⁻¹
51	500 210 00	1	32 x 1,2 DIN 472
52	502 773 00	0 ... 1	37 x 47 x 0,5 DIN 988
52	501 327 00	0 ... 3	37 x 47 x 0,1 DIN 988
53	501 307 00	2	
54	034 697 00	2	
55	500 217 00	2	47 x 1,75 DIN 472

Tafel Nr.
Table No.
Tableau No.
Tabla No.

07

Drehzahlverstellung
Speed control
Reglage regime
Ajuste de revoluciones

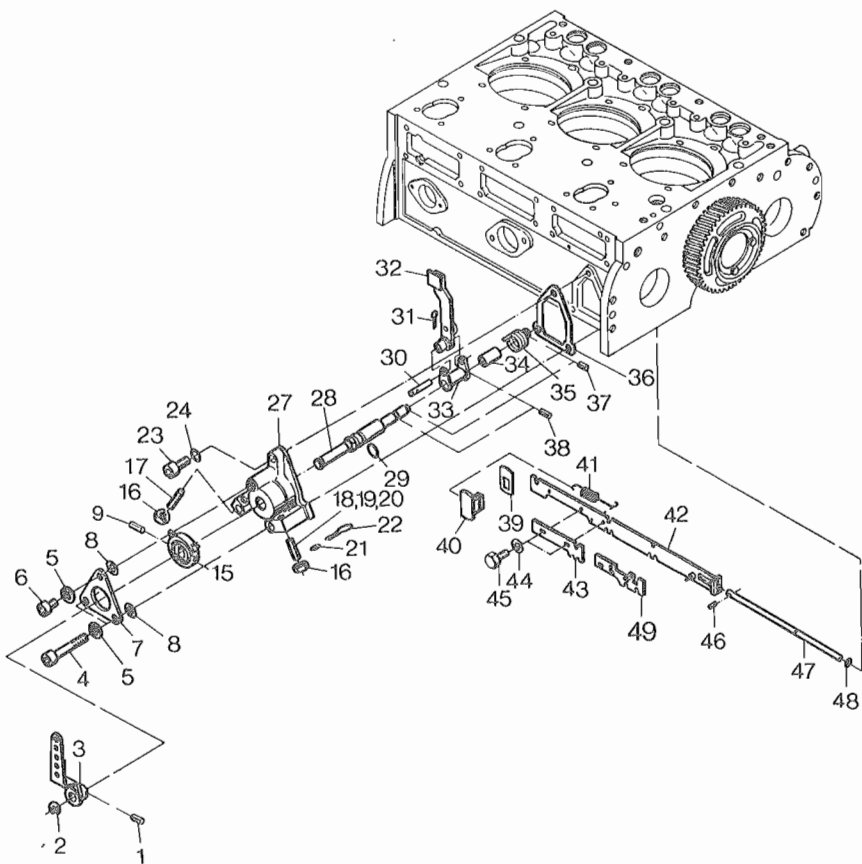

	Bestell-Nr. Ordering No. No. référence No. de pedido	Stück Quantity Quantites Cantidades	Hinweise Hints Indications Indicaciones	
3 L.30 S/Z/C				
1	501 320 00	1	4 x 16	DIN 1481
2	501 529 00	1		
3	007 920 01	1		
4	500 530 00	2	M 8 x 70	DIN 912-8.8
5	501 282 00	3	8	DIN 127
6	500 516 00	1	M 8 x 16	DIN 912-8.8
7	034 658 00	1		
8	032 130 00	0...3	0,3 mm	
8	032 131 00	0...3	0,5 mm	
9	500 350 00	1	5 x 40	DIN 1481
10	—	—		
11	—	—		
12	—	—		
13	—	—		
14	—	—		
15	034 688 10	1		
16	500 229 00	2	M 8	DIN 934-8
17	032 459 00	1		
18	032 459 00	1	35 mm	$n > 2600 \text{ min}^{-1}$
19	037 740 00	1	40 mm	$n = 2200 \dots 2600 \text{ min}^{-1}$
19	036 429 00	1	45 mm	$n = 2200 \dots 2600 \text{ min}^{-1}$
20	031 695 01	1	50 mm	$n < 2200 \text{ min}^{-1}$
21	400 214 00	1		
22	400 215 00	1		
23	500 519 00	1	M 8 x 20	DIN 912-8.8
24	501 629 00	1	A 8 x 14	DIN 7603-Cu
25	—	—		
26	—	—		
27	035 542 10	1		
28	034 689 20	1		
29	400 817 00	1		
30	034 690 00	1		
31	500 361 00	1	2 x 22	DIN 94
32	007 399 10	1		
33	034 691 00	1		

Tafel Nr.
Table No.
Tableau No.
Tabla No.

07

Drehzahlverstellung
Speed control
Reglage regime
Ajuste de revoluciones

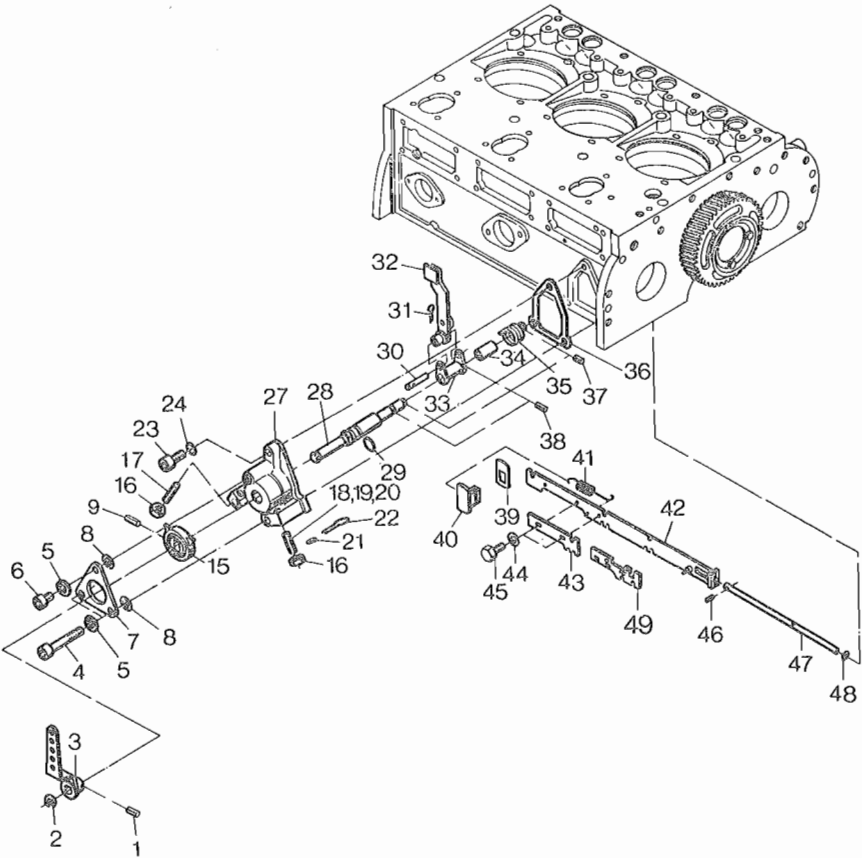

07

	Bestell-Nr. Ordering No. No. référence No. de pedido	Stück Quantity Quantites Cantidades	Hinweis Hints Indications Indicaciones	
		3 L 30 S/Z/C		
34	034 678 00	1		
35	034 679 00	1		
36	034 659 00	1		
37	501 320 00	1	4 x 16	DIN 1481
38	501 319 00	1	4 x 12	DIN 1481
39	036 432 00	0...3		
40	035 626 00	1		
41	034 681 00	1		
42	007 403 12	1		
43	034 685 01	1		
44	500 034 00	4	A 4	DIN 137
45	502 504 00	4	M 4 x 7	DIN 933-8.8
46	501 318 00	1	2,5 x 10	DIN 1481
47	034 606 00	1		
48	400 223 00	1		
49	010 654 00	1		

Tafel Nr.
Table No.
Tableau No.
Tabla No.

07

Drehzahlverstellung — 3 M 40
Speed control — 3 M 40
Reglage regime — 3 M 40
Ajuste de revoluciones — 3 M 40

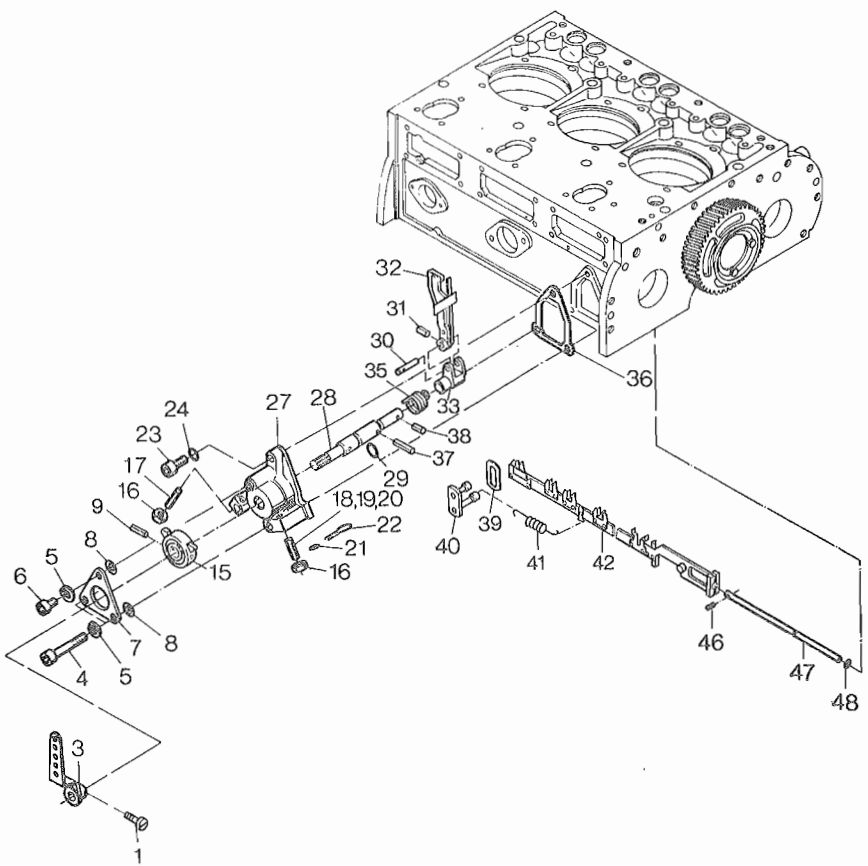

	Bestell-Nr. Ordering No. No. référence No. de pedido	Stück Quantity Quantites Cantidades	Hinweise Hints Indications Indicaciones	
		3 M 40		
1	500 494 00	1	M 5 x 20	DIN 84-4.8
2	—	—		
3	007 920 10	1		
4	500 530 00	2	M 8 x 70	DIN 912-8.8
5	501 282 00	3	8	DIN 127
6	500 516 00	1	M 8 x 16	DIN 912-8.8
7	034 658 00	1		
8	032 130 00	0...3	0,3 mm	
8	032 131 00	0...3	0,5 mm	
9	500 350 00	1	5 x 40	DIN 1481
10	—	—		
11	—	—		
12	—	—		
13	—	—		
14	—	—		
15	034 688 10	1		
16	500 229 00	1	M 8	DIN 934-8
17	032 459 00	1	AM 8 x 35	
18	032 459 00	1	35 mm	$n > 2600 \text{ min}^{-1}$
19	036 429 00	1	45 mm	$n = 2200 \dots 2600 \text{ min}^{-1}$
19	037 740 00	1	40 mm	$n = 2200 \dots 2600 \text{ min}^{-1}$
20	031 695 01	1	50 mm	$n < 2200 \text{ min}^{-1}$
21	400 214 00	1		
22	400 215 00	1		
23	500 519 00	1	M 8 x 20	DIN 912-8.8
24	501 629 00	1	A 8 x 14	DIN 7603-Cu
25	—	—		
26	—	—		
27	035 542 11	1		
28	034 689 30	1		
29	400 817 00	1		
30	034 690 10	1		
31	501 275 00	1	3 x 14	DIN 1481
32	010 862 00	1		
33	034 691 10	1		
34	—	—		

Tafel Nr.
Table No.
Tableau No.
Tabla No.

07

Drehzahlverstellung – 3 M 40
Speed control – 3 M 40
Reglage regime – 3 M 40
Ajuste de revoluciones – 3 M 40

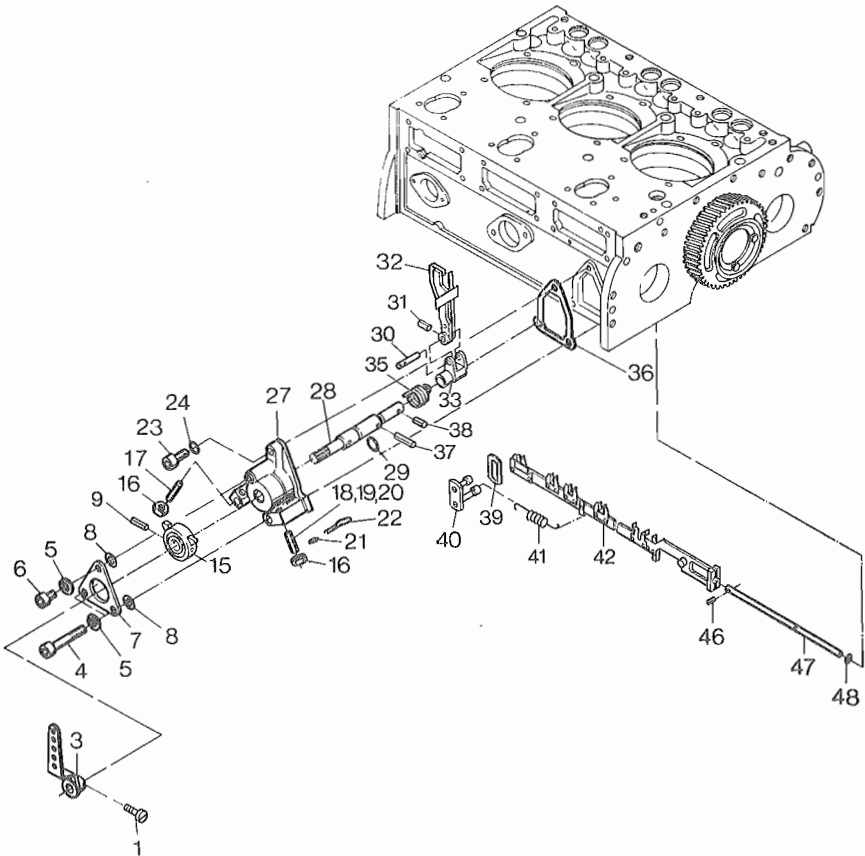

07

Bestell-Nr.
Ordering No.
No. référence
No. de pedido

Stück
Quantity
Quantités
Cantidades

Hinweise
Hints
Indications
Indicaciones

3 M 40

35	038 614 00	1		
36	034 659 00	1		
37	502 690 00	1	4 x 26	DIN 1481
38	501 319 00	1	4 x 12	DIN 1481
39	038 650 00	0...3		
40	030 667 00	1		
41	034 681 00	1		
42	010 669 02	1		
43	—	—		
44	—	—		
45	—	—		
46	501 318 00	1	2,5 x 10	DIN 1481
47	034 606 00	1		
48	400 223 00	1		

Tafel Nr.
Table No.
Tableau No.
Tabla No.

08

Pleuelstange, Kolben, Zylinder
Conrod, piston, cylinder
Bielle, piston, cylindre
Biela, émbolo, cilindro

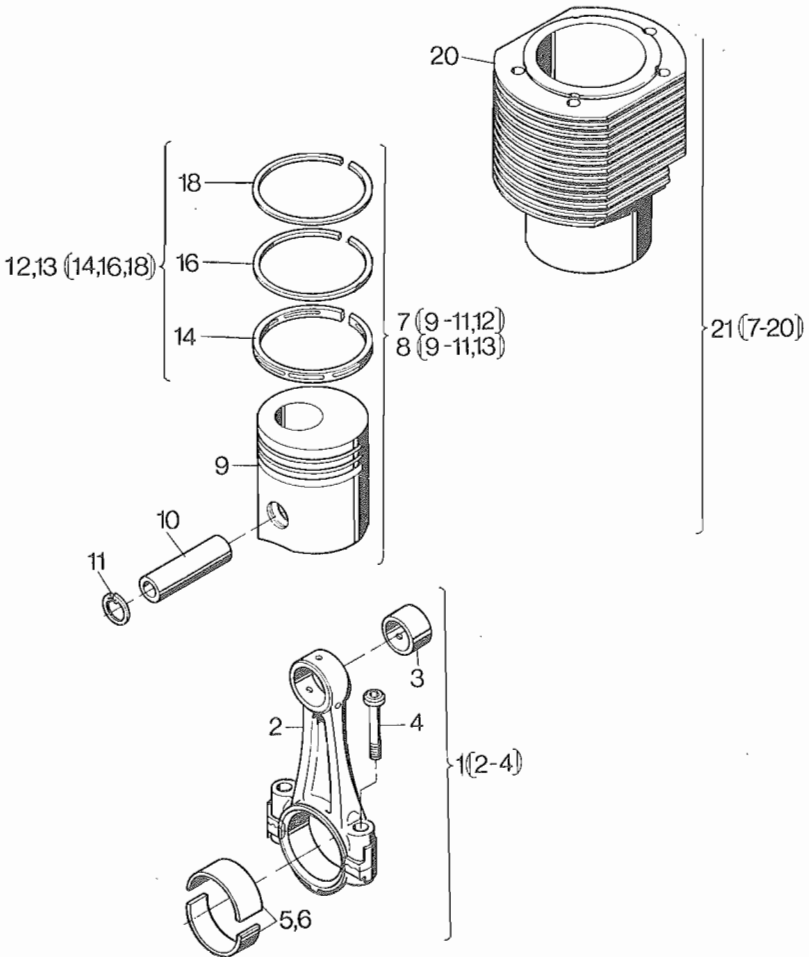

08

	Bestell-Nr. Ordering No. No. référence No. de pedido	Stück Quantity Quantités Cantidades		Hinweise Hints Indications Indicaciones
		3 L 30	3 M 40	
1	007 410 03	3	—	
1	009 297 01	—	3	
2	—	—	—	
3	036 212 00	3	—	
3	037 530 00	—	3	
4	034 695 00	6	6	
5	035 546 00	3	—	
5	036 184 01	—	3	
6	035 514 00	3	—	— 0,5
6	037 531 00	—	3	— 0,5
7	007 478 02	3	—	
7	009 541 01	—	3	
8	009 205 01	3	—	+ 1,0
8	009 722 00	—	3	+ 1,0
9	—	—	—	
10	502 035 00	3	—	
10	502 361 00	—	3	
11	500 210 00	6	—	32 x 1,2 DIN 472
11	502 360 00	—	6	36 x 1,5 DIN 472
12	009 196 01	3	—	
12	009 558 00	—	3	
13	009 197 01	3	—	+ 1,0
13	009 723 00	—	3	+ 1,0
14	—	—	—	
15	—	—	—	
16	—	—	—	
17	—	—	—	
18	—	—	—	
19	—	—	—	
20	035 587 00	3	—	
20	036 185 02	—	3	
21	009 265 00	3	—	
21	009 734 01	—	3	

Tafel Nr.
Table No.
Tableau No.
Tabla No.

09

Zylinderkopf
Cylinder head
Culasse
Culata

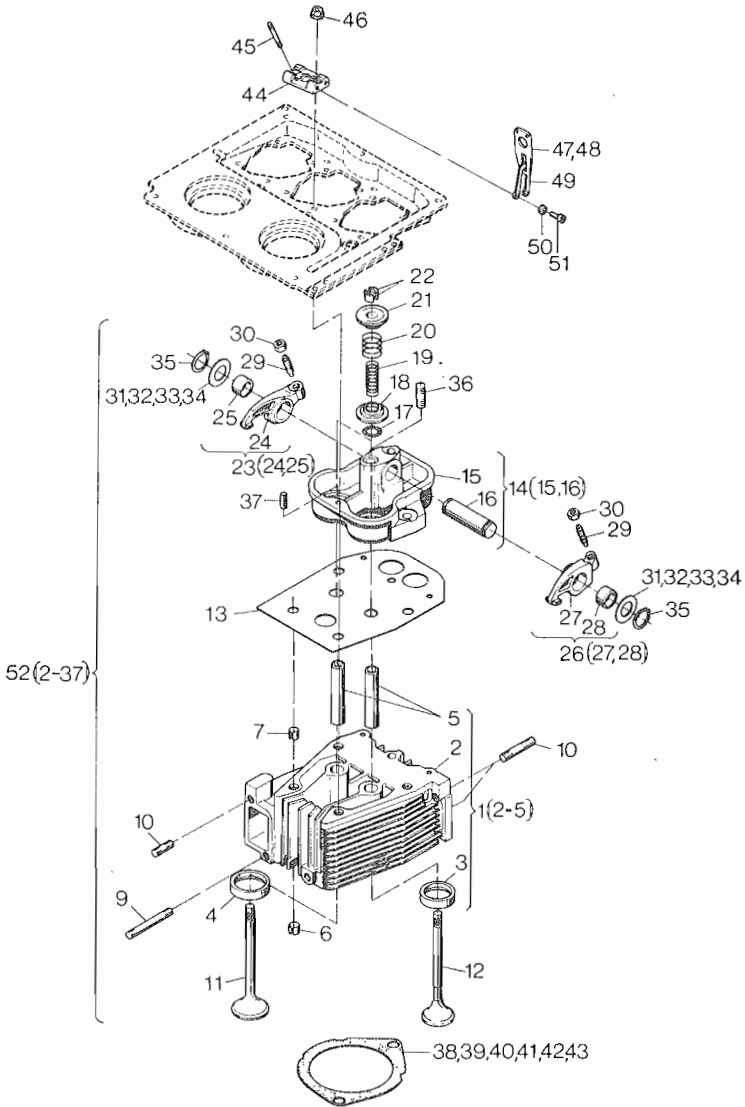

09

	Bestell-Nr. Ordering No. No. référence No. de pedido	Stück Quantity Quantites Cantidades			Hinweis Hints Indications Indicaciones
		3 L30 S/Z	3 L30 C	3 M 40	
1	007 390 01	3	3	—	
1	009 330 01	—	—	3	3 M 40 L
1	009 936 00	—	—	3	3 M 40 H
2	—	—	—	—	
3	—	—	—	—	
4	—	—	—	—	
5	034 487 01	6	6	6	
6	501 336 00	6	6	—	13 x 18 DIN 7346
7	501 277 00	12	12	—	12 x 14 DIN 7346
7	502 248 00	—	—	12	13 x 14 DIN 7346
9	501 325 00	3	3	3	M 8 x 65 DIN 835-8.8
10	501 281 00	9	9	9	M 8 x 30 DIN 835-10.9
11	036 145 00	3	3	—	
11	036 255 00	—	—	3	
12	036 146 00	3	3	—	
12	036 256 00	—	—	3	
13	035 665 00	3	3	—	
13	036 248 00	—	—	3	
14	009 424 01	3	3	—	
14	009 562 00	—	—	3	
15	—	—	—	—	
16	034 698 00	3	3	3	
17	502 255 00	6	6	6	
18	033 930 10	6	6	6	
19	031 835 00	6	6	6	
20	033 256 00	6	6	6	
21	030 434 02	6	6	6	
22	036 209 00	6	6	6	
23	005 325 00	3	3	3	
24	—	—	—	—	
25	031 841 00	3	3	3	
26	009 328 00	3	3	3	
27	—	—	—	—	
28	031 841 00	3	3	3	
29	030 431 00	6	6	6	n > 1800 min ⁻¹
29	037 720 00	6	6	6	n < 1800 min ⁻¹

Tafel Nr.
Table No.
Tableau No.
Tabla No.

09

Zylinderkopf
Cylinder head
Culasse
Culata

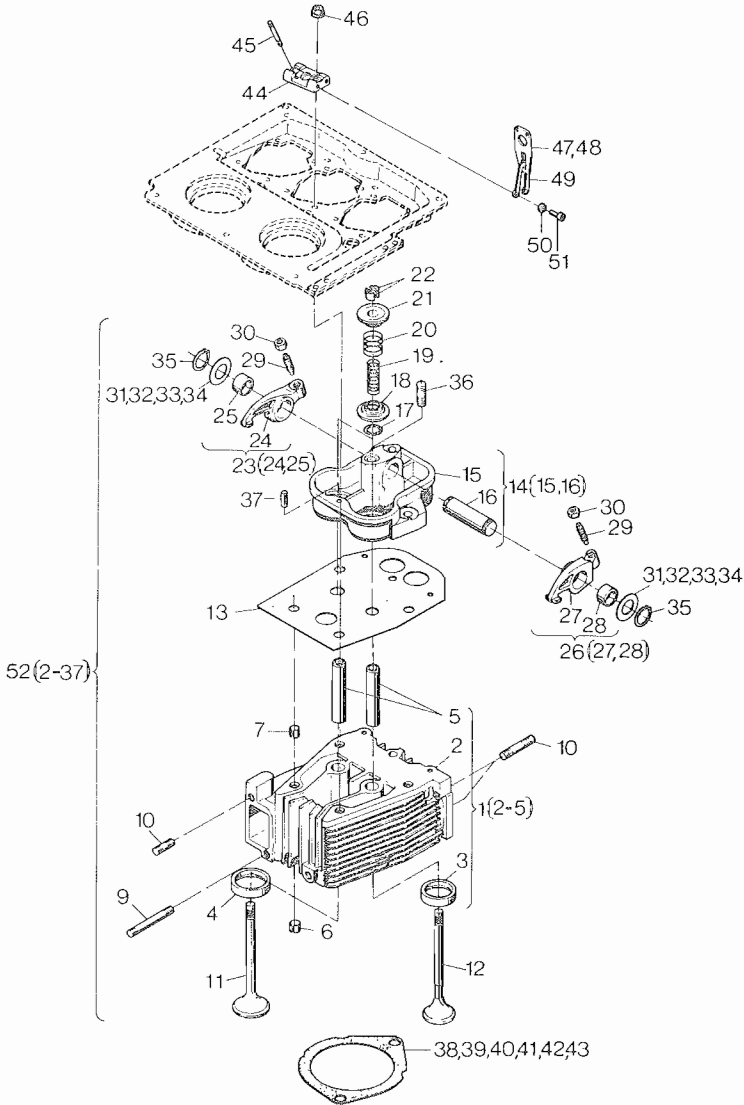

	Bestell-Nr.	Stück			Hinweise	
	Ordering No.	Quantity	Quantity	Quantity	Hints	
	No. référence	Quantites	Quantites	Quantites	Indications	
	No. de pedido	Cantidades	Cantidades	Cantidades	Indicaciones	
		3 L30 S/Z	3 L30 C	3 M 40		
30	031 490 00	6	6	6		
31	035 806 00	0...6	0...6	0...6	0,15 mm	
32	032 332 00	0...6	0...6	0...6	0,20 mm	
33	032 333 00	0...6	0...6	0...6	0,30 mm	
34	034 560 00	0...6	0...6	0...6	0,40 mm	
35	500 202 00	6	6	6	19 x 1,2	DIN 471
36	500 405 00	3	3	3	M 10 x 25	DIN 939-5.6
37	500 352 00	3	3	3	6 x 12	DIN 1481
38	035 588 00	3	3	—	0,7 mm	
38	036 259 01	—	—	3	0,7 mm	
39	035 589 00	3	3	—	0,8 mm	
39	036 260 01	—	—	3	0,8 mm	
40	035 590 00	3	3	—	0,9 mm	
40	036 261 01	—	—	3	0,9 mm	
41	035 591 00	3	3	—	1,0 mm	
41	036 262 01	—	—	3	1,0 mm	
42	035 592 00	3	3	—	1,1 mm	
42	036 263 01	—	—	3	1,1 mm	
43	035 593 00	3	3	—	1,2 mm	
43	036 264 01	—	—	3	1,2 mm	
44	034 661 00	3	3	—		
44	036 249 00	—	—	3		
45	501 287 00	6	6	—	M 8 x 50	DIN 939-8.8
45	502 390 00	—	—	6	M 8 x 55	DIN 939-8.8
46	032 150 00	15	15	—	M 9	
46	036 481 00	—	—	15	M 10 x 1,25	
47	035 691 00	1	—	1		
48	035 920 00	—	1	—		
49	035 692 00	1	1	—		
49	036 250 00	—	—	1		
50	501 282 00	2	2	2	8	DIN 127
51	501 297 00	2	2	2	M 8 x 18	DIN 912-10.9
52	009 195 01	3	3	—	$n > 1800 \text{ min}^{-1}$	
52	012 108 00	3	3	—	$n \leq 1800 \text{ min}^{-1}$	

Tafel Nr.
Table No.
Tableau No.
Tabla No.

10

Stoßstange, Ölpumpe
Pushrod, oil pump
Tige de culbuteur, pompe a huile
Varilla de balancin, bomba de aceite

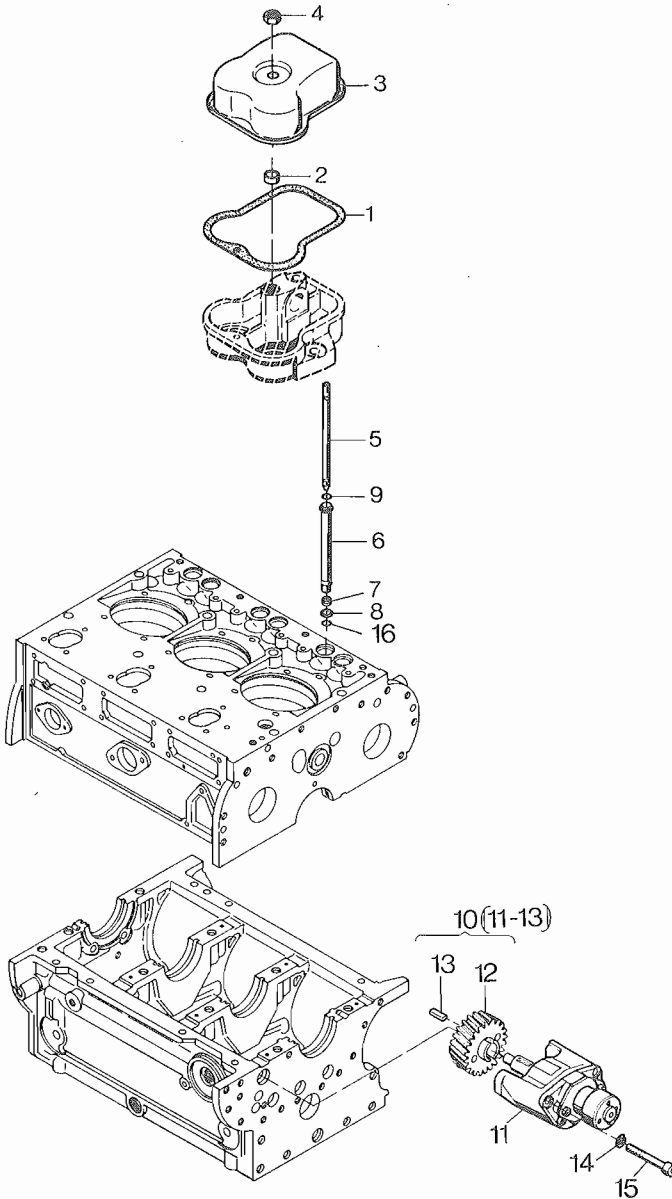

10

	Bestell-Nr. Ordering No. No. référence No. de pedido	Stück Quantity Quantities Cantidades		Hinweise Hints Indications Indicaciones
		3 L 30 S/Z/C	3 M 40	
1	034 699 00 W8	3	—	
1	502 249 00 W6	—	3	
2	036 083 00	3	—	
3	009 126 00	3	—	
3	036 426 01	—	3	
4	501 323 00 W6	3	3	M 10
5	007 436 00	6	6	
6	035 667 01	6	6	
7	031 851 00	6	6	
8	031 852 00	6	6	
9	502 580 00	6	6	
10	009 242 02	1	1	
11	—	—	—	
12	035 620 10	1	1	
13	500 108 00	1	1	4 x 4 x 25 DIN 6885
14	500 028 00	3	3	8 DIN 128
15	502 068 00	3	3	M 8 x 105 DIN 912-8.8
16	400 228 00	6	6	

Tafel Nr.
Table No.
Tableau No.
Tabla No.

11

Steuerdeckel, Startfüllung
Timing cover, extra fuel device
Couvercle distribut, surcharge
Tapa de mando, sobre alimentación-arranque

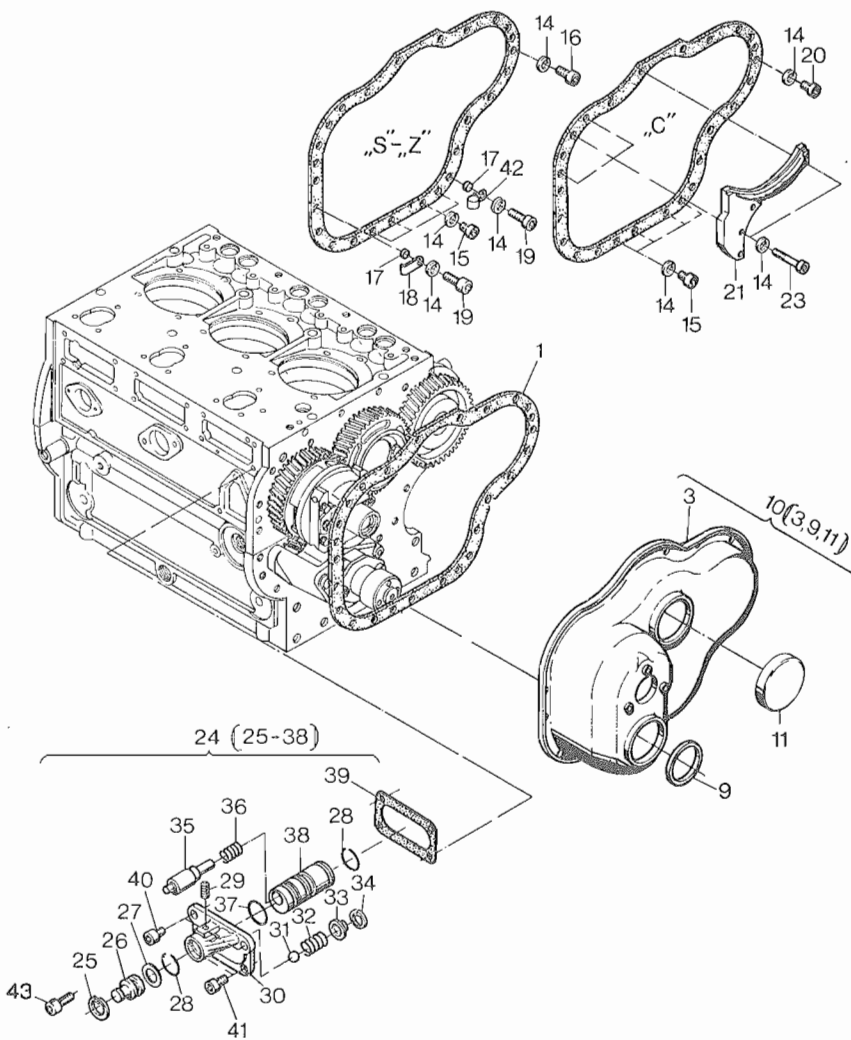

11

	Bestell-Nr. Ordering No. No. référence No. de pedido	Stück Quantity Quantités Cantidades	Hinweis Hints Indications Indicaciones		
		3 L 30 S/Z	3 L 30 C		
1	035 569 01	1	1		
2	—	—	—		
3	—	—	—		
4	—	—	—		
5	—	—	—		
6	—	—	—		
7	—	—	—		
8	—	—	—		
9	501 291 00	1	1		
10	009 932 00	1	1		
11	501 265 00	1	1		
12	—	—	—		
13	—	—	—		
14	500 028 00	22	22	8	DIN 128
15	502 058 00	4	4	M 8 x 12	DIN 912.8.8
16	500 516 00	17	—	M 8 x 16	DIN 912.8.8
17	031 182 00	2	—		
18	031 592 00	1	—		
19	500 521 00	2	—	M 8 x 25	DIN 912.8.8
20	500 516 00	—	13	M 8 x 16	DIN 912.8.8
21	009 028 00	—	1		
22	—	—	—		
23	500 528 00	—	5	M 8 x 55	DIN 912.8.8
24	007 400 01	1	1		
25	502 039 00	1	1	18 x 1	DIN 472
26	036 151 00	1	1		
27	502 245 00	1	1		
28	501 423 00	2	2	28	DIN 7993
29	501 424 00	1	1	M 6 x 10	DIN 914-45 H
30	—	—	—		
31	500 099 00	1	1	8 mm	DIN 5401
32	—	—	—		
33	—	—	—		
34	501 425 00	1	1	11 x 1	DIN 472
35	—	—	—		
36	—	—	—		

Tafel Nr.
Table No.
Tableau No.
Tabla No.

11

Steuerdeckel, Startfüllung
Timing cover, extra fuel device
Couvercle distribut, surcharge
Tapa de mando, sobre alimentación-arranque

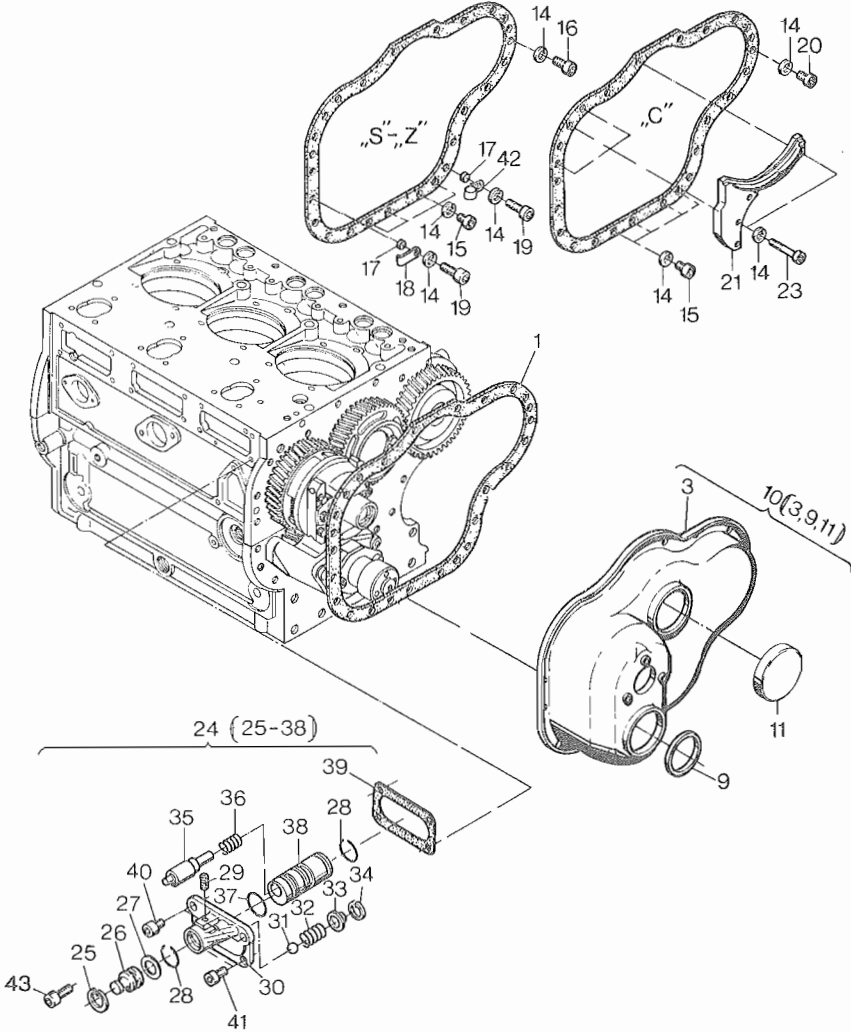

11

	Bestell-Nr. Ordering No. No. référence No. de pedido	Stück Quantity Quantites Cantidades		Hinweise Hints Indications Indicaciones	
		3 L 30 S/Z	3 L 30 C		
37	501 422 00	2	2		
38	—	—	—		
39	036 140 00	1	1		
40	400 808 00	2	2	M 8 x 20	DIN 912.8.8
41	501 289 00	1	1	M 8 x 16	DIN 912.8.8
42	031 655 00	1	—		
43	502 579 00	1	1	M 8 x 16	DIN 6912-8.8

Tafel Nr.
 Table No.
 Tableau No.
 Tabla No.

11

Steuerdeckel, Startfüllung – 3 M 40
 Timing cover, extra fuel device – 3 M 40
 Couvercle distribut, surcharge – 3 M 40
 Tapa de mando, sobre alimentación-arranque – 3 M 40

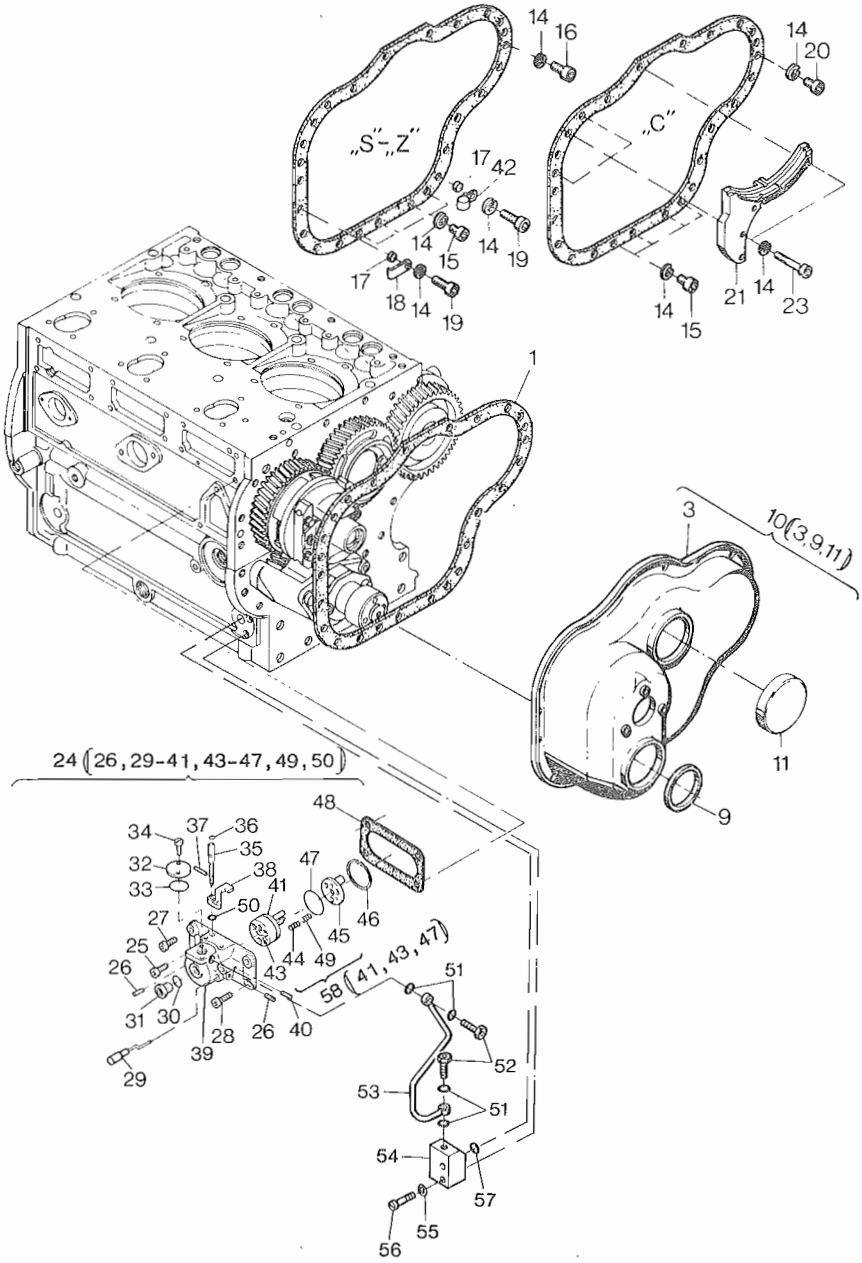

	Bestell-Nr. Ordering No. No. référence No. de pedido	Stück Quantity Quantités Cantidades	Hinweise Hints Indications Indicaciones	
		3 M 40		
1	035 569 01	1		
2	—	—		
3	—	—		
4	—	—		
5	—	—		
6	—	—		
7	—	—		
8	—	—		
9	501 291 00	1		
10	009 932 00	1		
11	501 265 00	1		
14	500 028 00	22	8	DIN 128
15	502 058 00	4	M 8 x 12	DIN 912-8.8
16	500 516 00	16	M 8 x 16	DIN 912-8.8
17	031 182 00	2		
18	031 592 00	1		
19	500 521 00	2	M 8 x 25	DIN 912-8.8
20	500 516 00	—	M 8 x 16	DIN 912-8.8
21	009 028 00	—		
22	—	—		
23	500 528 00	—	M 8 x 55	DIN 912-8.8
24	012 019 01	1		
25	501 349 00	1	M 8 x 16	DIN 6912-8.8
26	502 624 00	2	M 10 x 6	DIN 916
27	501 289 00	1	M 8 x 16	DIN 912
28	400 808 00	2	M 8 x 20	DIN 912
29	010 762 00	1		
30	500 012 00	1	14 x 18	DIN 7603-Cu
31	501 435 00	1	M 14 x 1,5	DIN 908
32	038 591 00	1		
33	501 304 00	1	16,3 x 2,4 x 21,1	
34	500 492 00	2	M 4 x 10	DIN 84-4.8 A3C
35	038 288 00	1		
36	400 217 00	1	4,47 x 8,03 x 1,78	
37	501 318 00	1	2,5 x 10	DIN 1481
38	036 702 10	1		

Tafel Nr.
Table No.
Tableau No.
Tabla No.

11

Steuerdeckel, Startfüllung — 3 M 40
Timing cover, extra fuel device — 3 M 40
Couvercle distribut, surcharge — 3 M 40
Tapa de mando, sobre alimentación-arranque — 3 M 40

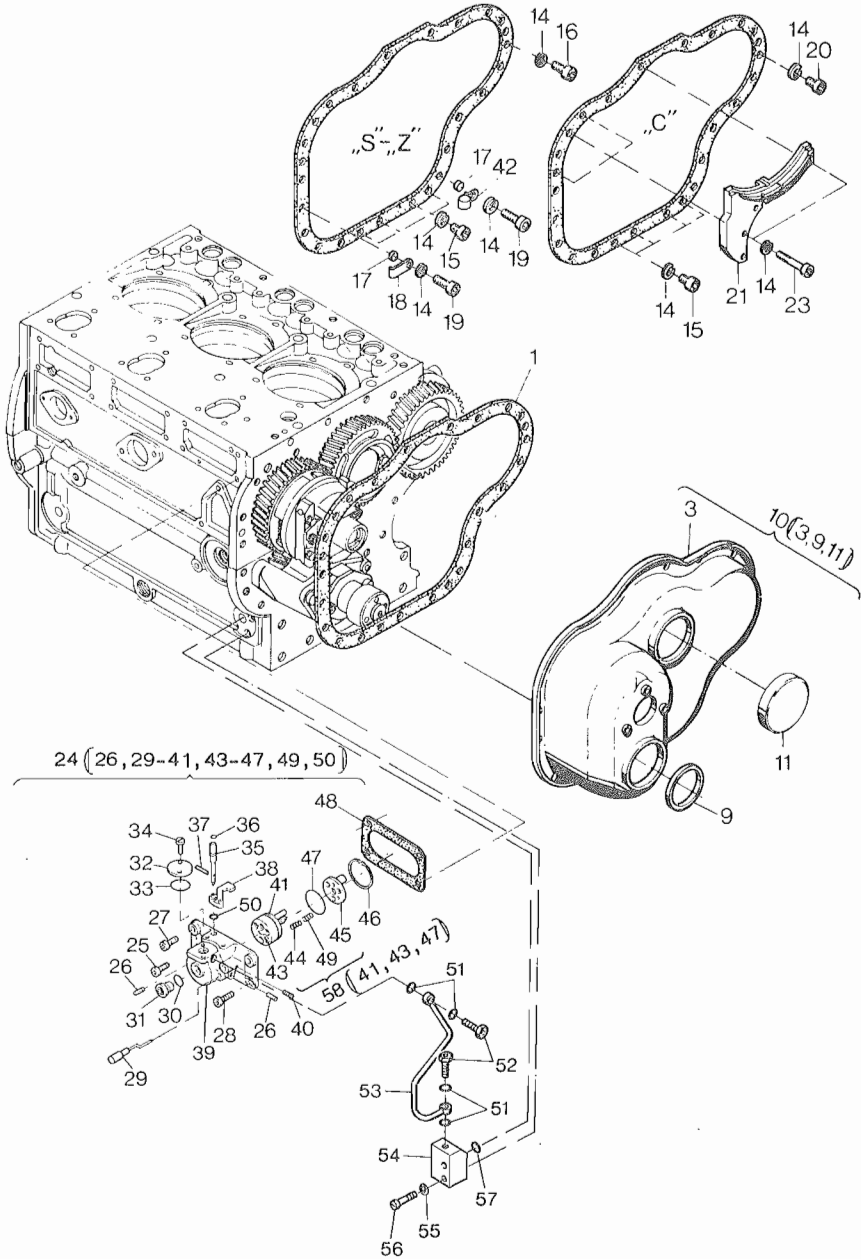

	Bestell-Nr. Ordering No. No. référence No. de pedido	Stück Quantity Quantites Cantidades		Hinweise Hints Indications Indicaciones	
		3 M 40			
39	—	—	—		
40	502 863 00	1	1	6 x 16	DIN 915-45 H
41	—	—	—		
42	031 655 00	1	—		
43	501 543 00	1	1	7,5 x 10,5 x 1,5	
44	038 811 00	3	3		
45	038 542 00	1	1		
46	500 215 00	1	1	42 x 1,75	DIN 472
47	502 631 00	1	1	37,8 x 1,5	
48	036 140 00	1	1		
49	038 813 00	3	3		
50	501 172 00	1	1	4	DIN 6799
51	500 009 00	4	4	A 8 x 11,5	DIN 7603 Cu
52	500 061 00	2	2	A 2/3	DINN 7623 Zn
53	038 801 00	1	1		
54	038 806 00	1	1		
55	500 035 00	2	2	B 8	DIN 137
56	500 523 00	2	2	M 8 x 35	DIN 912-8.8
57	501 304 00	1	1	16,3 x 2,4	
58	012 018 10	1	1		

Tafel Nr.
Table No.
Tableau No.
Tabla No.

12

Gebläse
Blower
Soufflerie
Ventilador

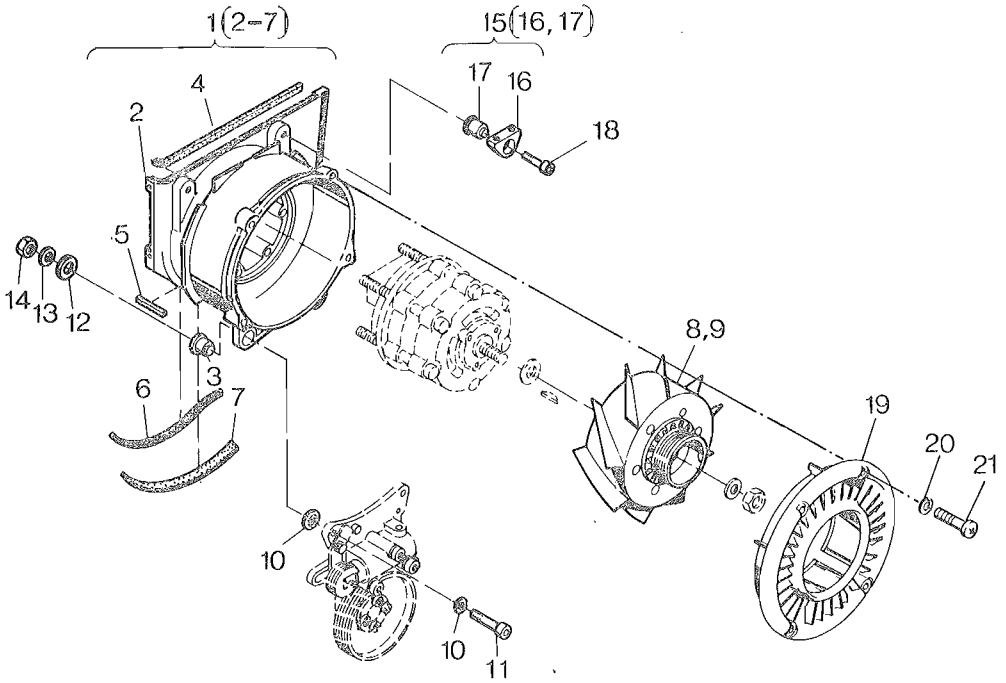

	Bestell-Nr.	Stück			Hinweise	
	Ordering No.	Quantity	3 L30 S/Z	3 L30 C	3 M 40	Hints
	No. référence	Quantites				Indications
	No. de pedido	Cantidades				Indicaciones
			3 L30 S/Z	3 L30 C	3 M 40	
1	007 402 01	1	—	—	1	
1	012 037 00	—	—	1	—	
2	—	—	—	—	—	
3	035 625 00	2	2	2	2	
4	035 526 00	1	1	1	1	335 mm
5	035 985 00	1	1	1	1	33 mm
6	035 524 01	1	1	1	1	240 mm
7	036 127 00	1	1	1	1	193 mm
8	009 209 01	1	—	—	—	
8	009 897 01	—	—	—	1	
9	012 051 01	—	—	1	—	
10	500 617 00	4	4	4	4	A 10 DIN 137
11	500 551 00	2	2	2	2	M 10 x 55 DIN 912-8.8
12	500 706 00	2	2	2	2	10,5 DIN 7349
13	501 278 00	2	2	2	2	A 10 DIN 127
14	500 235 00	2	2	2	2	M 10 DIN 934-8
15	009 198 00	2	2	2	2	
16	—	—	—	—	—	
17	035 625 00	2	2	2	2	
18	500 526 00	2	2	2	2	M 8 x 45 DIN 912-8.8
19	037 628 00	—	—	1	—	
20	500 812 00	—	—	4	—	A 6 DIN 137
21	502 532 00	—	—	4	—	M 6 x 50 A3R DIN 7985-4.8

Tafel Nr.
Table No.
Tableau No.
Tabla No.

13

Einspritzausrstung
Injection equipment
Equipement d'injection
Equipo de inyeccin

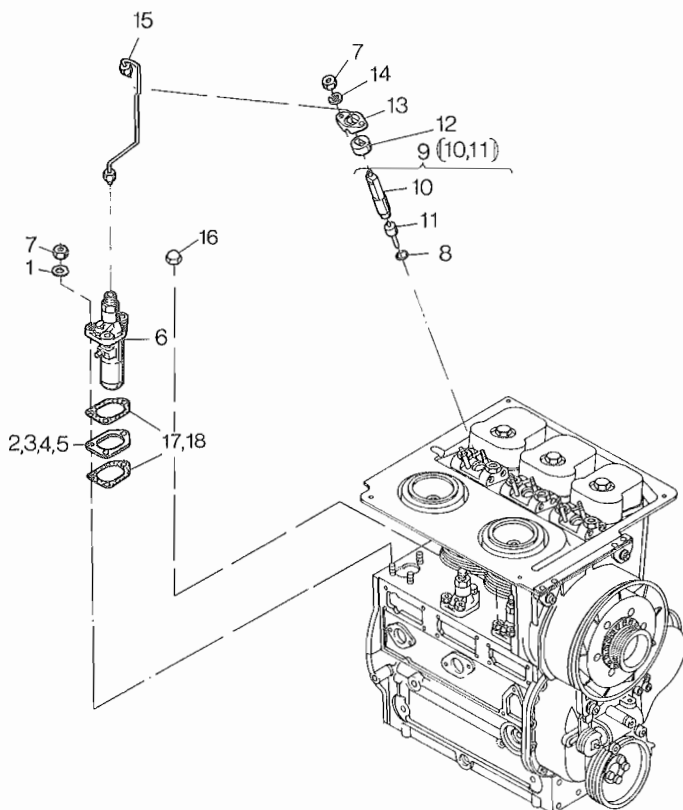

	Bestell-Nr. Ordering No. No. référence No. de pedido	Stück Quantity Quantites Cantidades		Hinweise Hints Indications Indicaciones	
		3 L 30	3 M 40		
1	500 035 00	—	9	B 8	DIN 137
2	031 683 01	0...3	—	0,15 mm	
2	502 739 00	—	0...6	0,30 mm	
3	031 685 00	0...3	—	0,20 mm	
3	502 738 00	—	0...6	0,60 mm	
4	031 686 00	0...3	—	0,25 mm	
4	502 737 00	—	0...3	0,90 mm	
5	031 687 00	0...3	—	0,30 mm	
5	502 736 00	—	0...3	1,20 mm	
6	501 407 10	3	—		
6	502 630 00	—	3		
7	500 229 00	14	14	M 8	DIN 934-8
8	400 850 00	3	3		
9	401 209 01	3	3		
10	—	—	—		
11	501 413 01 P1	3	3		
12	034 665 00	3	3		
13	034 605 00	3	3		
14	501 282 00	6	6	8	DIN 127
15	007 406 00	3	3	3 M 40 H, 3 L 30	
15	012 038 00	—	3	3 M 40 L	
16	502 676 00	—	1	M 8	DIN 1587
17	031 684 00	6	—		
17	502 735 00	—	0...6	0,20 mm	
18	502 734 00	—	0...6	0,20 mm	

Tafel Nr.
Table No.
Tableau No.
Tabla No.

14

Riemenscheibe, Schwungrad, Hydr. Abstellvorrichtung
Pulley, flywheel, hydr. belt tensioner
Poulie, volant, tendeur hydr.
Polea, volante, tensor hidráulico

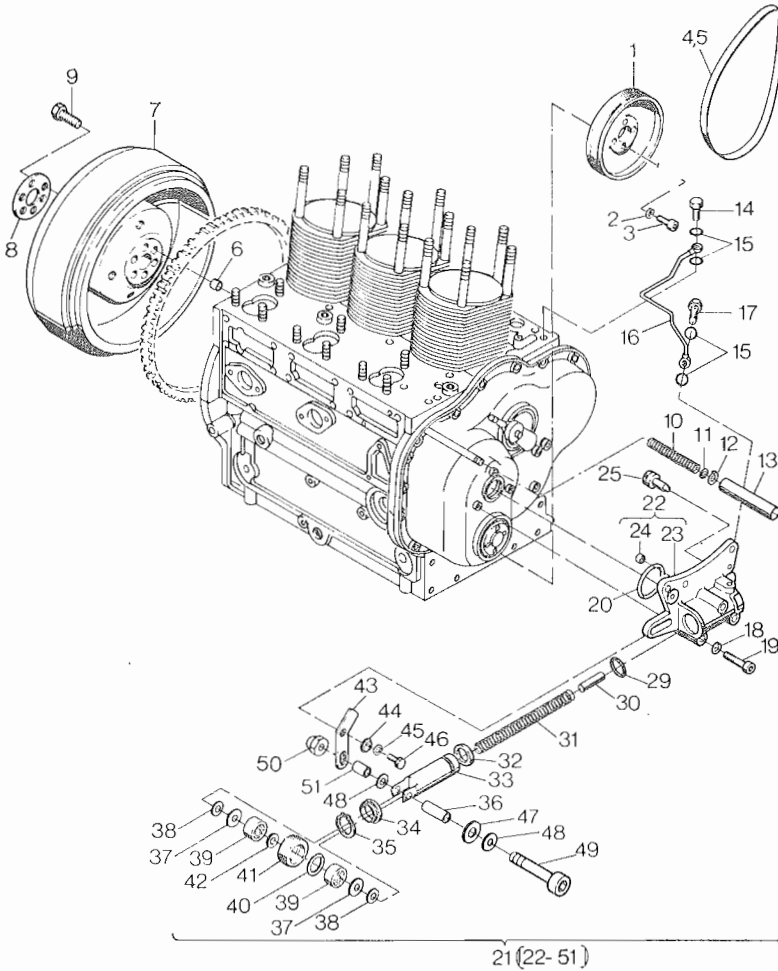

	Bestell-Nr.	Stück	Hinweise		
	Ordering No.	Quantity	Hints		
	No. référence	Quantities	Indications		
	No. de pedido	Cantidades	Indicaciones		
		3 L30 S/Z	3 L30 C	3 M40	
1	035 898 01	1	1	1	
2	501 282 00	4	4	4	8 DIN 127
3	500 519 00	4	4	4	M 8 x 20 DIN 931-8.8
4	502 031 00 P1	1	1	—	9 J 920
5	501 415 00 P1	—	—	1	9 J 910
6	031 237 00	1	1	—	
6	036 306 00	—	—	1	
7	036 908 01	1	1	—	SAE J 620
7	037 337 01	—	—	1	SAE J 620
8	034 624 00	1	1	—	
8	036 458 00	—	—	1	
9	501 292 00	6	6	—	M 12 x 45 DIN 931-12.9
9	502 251 00	—	—	6	M 14x1,5x45 DIN 912-10.4
10	034 680 00	1	1	1	
11	031 332 00	1	1	1	
12	500 194 00	1	1	1	8 x 0,8 DIN 471
13	035 682 00	1	1	1	
14	500 061 00	1	1	1	A 2/3 DIN 7623
15	500 009 00	4	4	4	A 8 x 11,5 DIN 7603-Cu
16	009 100 00	1	1	1	
17	500 061 00	1	1	1	
18	500 035 00	3	3	3	B 8 DIN 137
19	500 818 00	3	3	3	M 8 x 65 DIN 912-8.8
20	501 324 01	1	1	1	
21	009 414 03	1	1	1	
22	009 276 20	1	1	1	
23	—	—	—	—	
24	400 847 00	1	1	1	
25	037 506 00	1	1	1	
26	—	—	—	—	
27	—	—	—	—	
28	—	—	—	—	
29	502 197 00	1	1	1	
30	036 393 00	1	1	1	
31	035 891 00	1	1	1	
32	502 211 00	1	1	1	

Tafel Nr.
Table No.
Tableau No.
Tabla No.

14

Riemenscheibe, Schwungrad, Hydr. Abstellvorrichtung
Pulley, flywheel, hydr. belt tensioner
Poulie, volant, tendeur hydr.
Polea, volante, tensor hidráulico

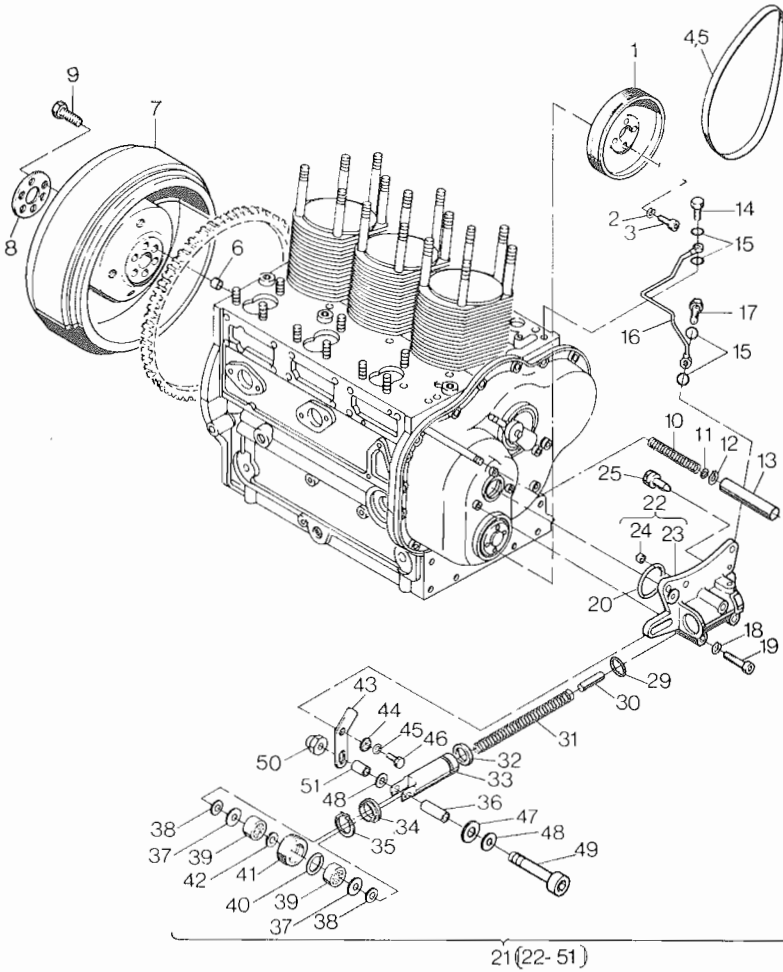

	Bestell-Nr.	Stück			Hinweise	
	Ordering No.	Quantity	Quantity	Quantity	Hints	
	No. référence	Quantities	Quantities	Quantities	Indications	
	No. de pedido	Cantidades	Cantidades	Cantidades	Indicaciones	
		3 L30 S/Z	3 L30 C	3 M40		
33	035 896 20	1	1	1		
34	036 430 00	1	1	1		
35	502 210 00	1	1	1	45 x 1,75	DIN 472
36	037 646 00	1	1	1		
37	502 500 00	2	2	2		
38	037 648 00	2	2	2		
39	502 499 00	2	2	2		
40	500 207 00	1	1	1	28 x 1,2	DIN 472
41	035 894 20	1	1	1		
42	501 321 00	1	1	1	12 x 18 x 1,2	
43	035 895 10	1	1	1		
44	035 893 00	1	1	1		
45	500 027 00	1	1	1	6	DIN 128
46	500 258 00	1	1	1	M 6 x 20	DIN 933-8.8
47	037 649 00	1	1	1		
48	500 167 00	2	2	2	A 8,4	DIN 125 St
49	500 818 00	1	1	1	M 8 x 65	DIN 912-8.8
50	400 284 00	1	1	1	M 8	SSN 440-8 Cu
51	037 647 00	1	1	1		

Tafel Nr.
Table No.
Tableau No.
Tabla No.

15

Luftfilter, Luftansaugrohr
Air filter, air intake manifold
Filtre à air, collecteur d'admission
Filtro de aire, tubo de aspiración

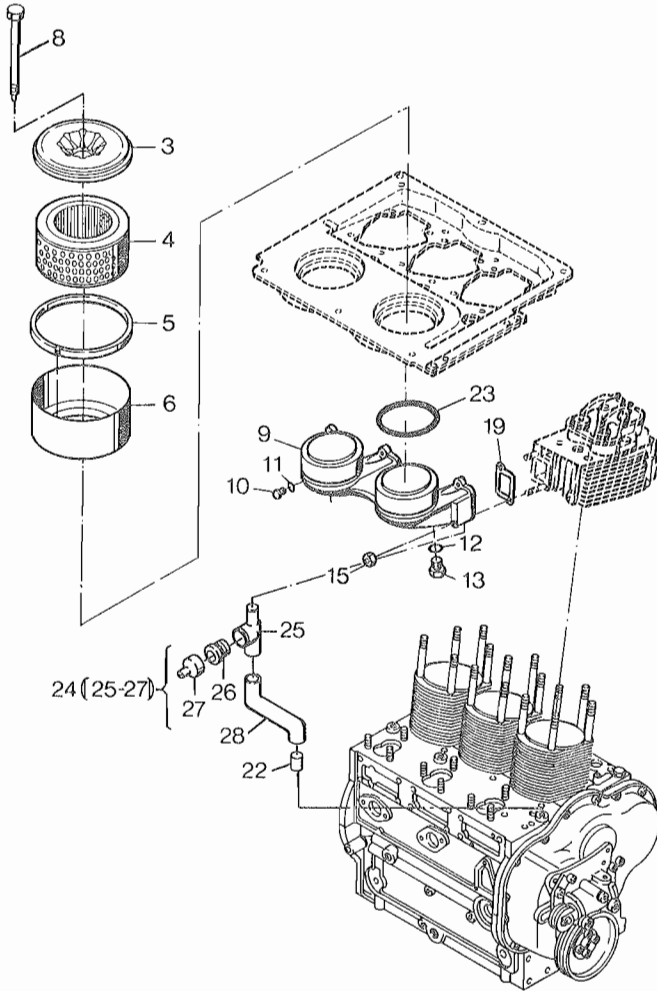

	Bestell-Nr. Ordering No. No. référence No. de pedido	Stück Quantity Quantites Cantidades		Hinweise Hints Indications Indicaciones
		3 L 30 S/Z/C	3 M 40	
1	--	--	--	
2	--	--	--	
3	009 047 10	2	--	
3	009 995 00	--	1	
4	400 845 00 W4	2	--	
4	009 529 00 W2	--	1	
5	035 838 00 W2	2	--	
5	037 698 00 W1	--	1	
6	036 206 00	2	--	
6	009 994 00	--	1	
7	--	--	--	
8	037 523 01	2	2	
9	035 961 03	1	--	
9	036 321 03	--	1	
10	500 623 00	1	1	M 10 x 1 DIN 908-4.6 A3C
11	500 624 00	1	1	A 10 x 13,5 DIN 7603-Cu
12	500 016 00	1	1	A 22 x 27 DIN 7603-Cu
13	501 404 00	1	1	AM 22 x 2,5 DIN 7604
14	--	--	--	
15	502 236 00	6	6	M 8 A3C
16	--	--	--	
17	--	--	--	
18	--	--	--	
19	034 615 00	3	--	
19	036 244 00	--	3	
20	--	--	--	
21	--	--	--	
22	036 490 00	1	1	
23	035 977 00	2	--	
23	036 486 00	--	1	
24	009 478 00	1	1	
25	--	--	--	
26	035 687 00	1	1	
27	035 686 00	1	1	
28	036 489 00	1	1	

Tafel Nr.
Table No.
Tableau No.
Tabla No.

16

Luftführung
Air ducting
Carter ventilation
Conducción de aire

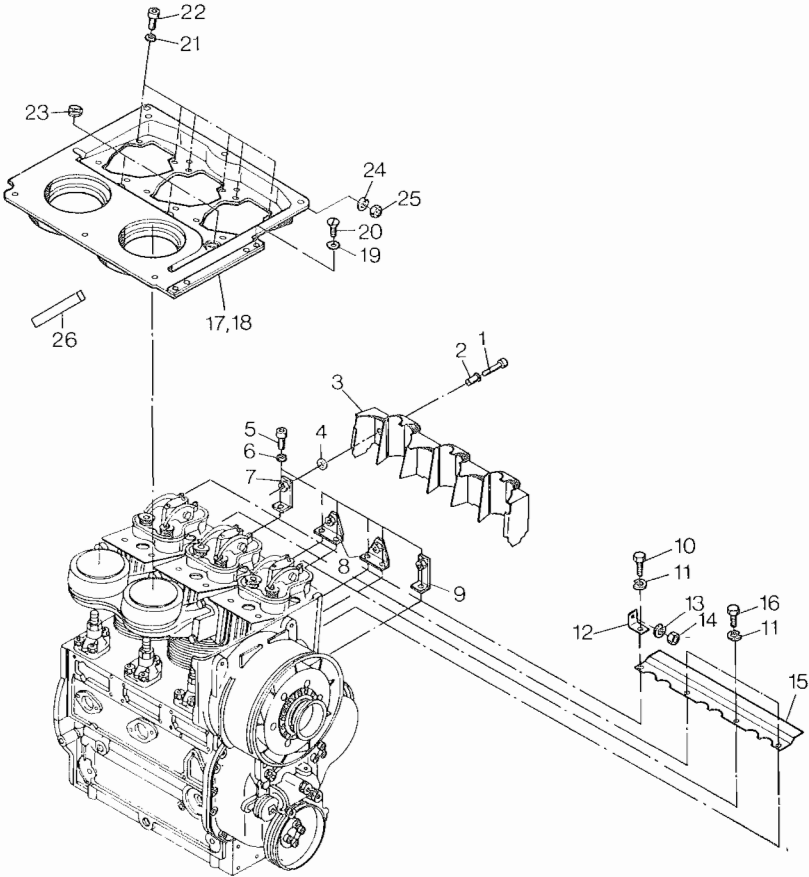

	Bestell-Nr.	Stück			Hinweise	
	Ordering No.	Quantity	Quantity	Quantity	Hints	
	No. référence	Quantities	Quantities	Quantities	Indications	
	No. de pedido	Cantidades	Cantidades	Cantidades	Indicaciones	
		3 L30 S/Z	3 L30 C	3 M 40		
1	500 511 00	4	4	4	M 6 x 30	DIN 6912-8.8
2	009 327 00	4	4	4		
3	009 381 00	1	1	1		
4	035 755 00	4	4	4		
5	500 516 00	6	6	6	M 8 x 16	DIN 912-8.8
6	500 028 00	6	6	6	8	DIN 128
7	009 234 00	1	1	1		
8	009 233 00	2	2	2		
9	009 235 00	1	1	1		
10	500 267 00	---	1	---	M 8 x 16	DIN 933-8.8
11	500 028 00	---	6	---	8	DIN 128
12	035 856 01	---	1	---		
13	500 812 00	---	9	---	A 6	DIN 137
14	500 227 00	---	7	---	M 6	DIN 934-8
15	035 915 01	---	1	---		
16	500 266 00	---	3	---	M 8 x 12	DIN 933-8.8
17	009 141 01	1	---	---		
17	009 395 01	---	---	1		
18	009 140 00	---	1	---		
19	502 051 00	4	4	4	V 8,4	DIN 6797
20	502 052 00	4	4	4	M 8 x 16	DIN 965-8.8
21	500 812 00	6	6	6	A 6	DIN 137
22	500 507 00	6	6	6	M 6 x 16	DIN 912-8.8
23	035 927 00	3	3	3		
24	500 027 00	3	---	3	6	DIN 128
25	500 227 00	3	---	3	M 6	DIN 934-8
26	036 485 00	---	---	1	175 mm	

Tafel Nr.
Table No.
Tableau No.
Tabla No.

17

Luftführung S/Z
Air ducting S/Z
Carter ventilation S/Z
Conducción de aire S/Z

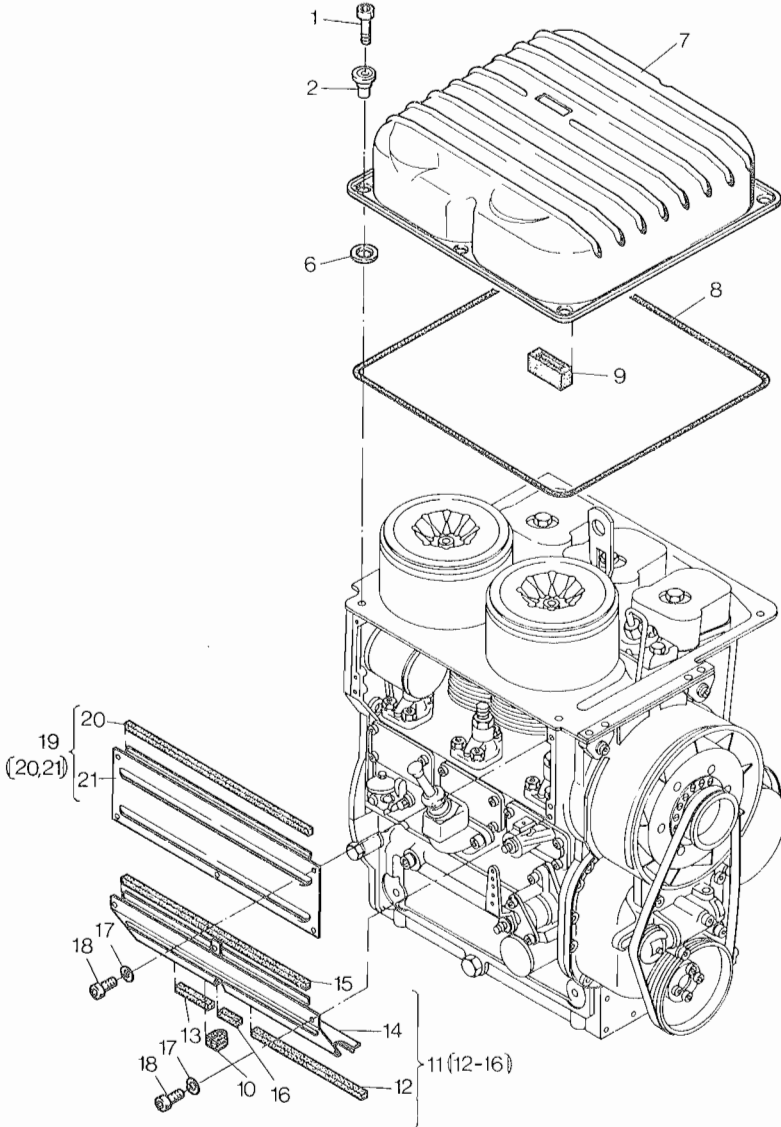

	Bestell-Nr. Ordering No. No. référence No. de pedido	Stück Quantity Quantités Cantidades		Hinweise Hints Indications Indicaciones
		3 L 30 S/Z	3 M 40	
1	501 144 00	5	—	M 8 x 25 DIN 6912-8.8
2	009 214 00	5	—	
3	—	—	—	
4	—	—	—	
5	—	—	—	
6	035 755 00	5	—	
7	007 423 01	1	—	
8	035 629 00	1	—	
9	035 690 00	1	—	
10	035 689 00	1	1	
11	007 428 10	1	—	$S \leq 2500 \text{ min}^{-1} / Z \leq 2000 \text{ min}^{-1}$
11	007 428 11	—	1	$n \leq 1500 \text{ min}^{-1}$
11	010 807 00	—	1	$\left\{ \begin{array}{l} n \leq 1500 \text{ min}^{-1} \\ \text{(f. Taf./Tabl. 26., Pos. 76)} \end{array} \right.$
11	008 158 10	1	—	$\left\{ \begin{array}{l} S \leq 2500 \text{ min}^{-1} / Z \leq 2000 \text{ min}^{-1} \\ \text{(f. Taf./Tabl. 26, Pos. 46-75)} \end{array} \right.$
12	035 637 01	1	1	214 mm
13	035 638 00	1	1	67 mm
14	—	—	—	
15	035 636 00	2	2	173 mm
16	035 985 00	1	1	32 mm
17	500 812 00	8	8	A 6 DIN 137
18	501 330 00	8	8	M 6 x 12 DIN 6912-8.8
19	007 426 00	1	1	
20	035 631 00	1	1	366 mm
21	—	—	—	

Tafel Nr.
Table No.
Tableau No.
Tabla No.

18

Luftführung
Air ducting
Carter ventilation
Conducción de aire

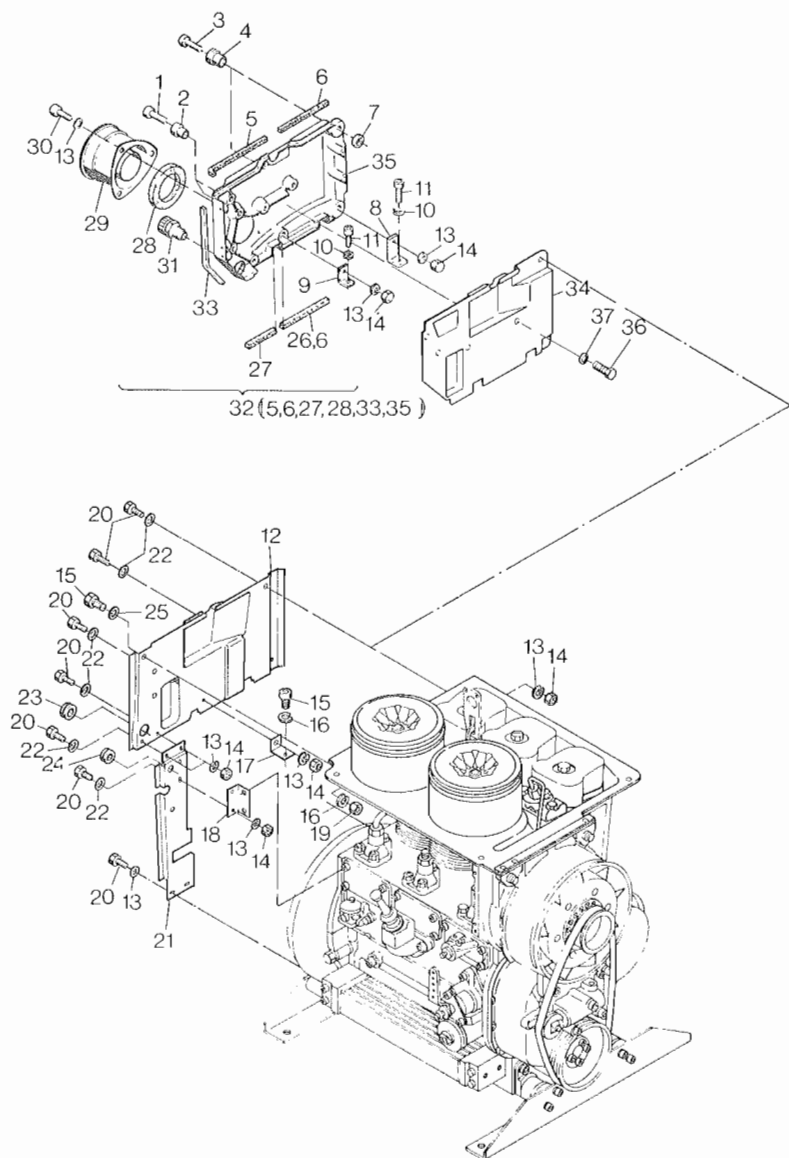

	Bestell-Nr. Ordering No. No. référence No. de pedido	Stück Quantity Quantités Cantidades			Hinweise Hints Indications Indicaciones	
		3 L30 S/Z	3 L30 C	3 M 40		
1	500 510 00	—	—	2	M 6 x 30	DIN 912-8.8
2	009 327 00	—	—	2		
3	500 511 00	3	—	2	M 6 x 30	DIN 6912-8.8
4	009 215 00	3	—	2		
5	035 601 00	1	—	—	210 mm	
5	035 637 01	—	—	1	214 mm	
6	035 600 00	1	—	—	117 mm	
6	035 651 00	1	—	1	113 mm	
7	035 755 00	3	—	4		
8	036 468 00	—	—	1		
9	035 741 00	1	—	—		
9	036 469 00	—	—	1		
10	500 028 00	1	—	2	8	DIN 128
11	500 516 00	1	—	2	M 8 x 16	DIN 912-8.8
12	009 090 02	—	1	—		
13	500 812 00	—	9	—	A 6	DIN 137
14	500 227 00	—	8	—	M 6	DIN 934-8
15	500 516 00	—	2	—	M 8 x 16	DIN 912-8.8
16	500 028 00	—	2	—	8	DIN 128
17	035 741 00	—	1	—		
18	035 901 00	—	1	—		
19	500 229 00	—	1	—	M 8	DIN 934-8
20	500 255 00	—	8	—	M 6 x 12	DIN 933-8.8
21	035 861 01	—	1	—		
22	500 166 00	—	7	—	6,4	DIN 125-St
23	501 998 00	—	1	—		DIN 7044
24	035 654 00	—	1	—		
25	500 167 00	—	1	—	8,4	DIN 125-St
26	035 651 00	1	—	1		113 mm
27	035 602 00	1	—	1		93 mm
28	—	—	—	—		
29	009 537 00	—	—	1		
30	500 506 00	—	—	3	M 6 x 12	DIN 912-8.8
31	501 590 10	1	—	—		
32	007 415 01	1	—	—		
32	009 532 00	—	—	1		

Tafel Nr.
Table No.
Tableau No.
Tabla No.

18

Lufführung
Air ducting
Carter ventilation
Conducción de aire

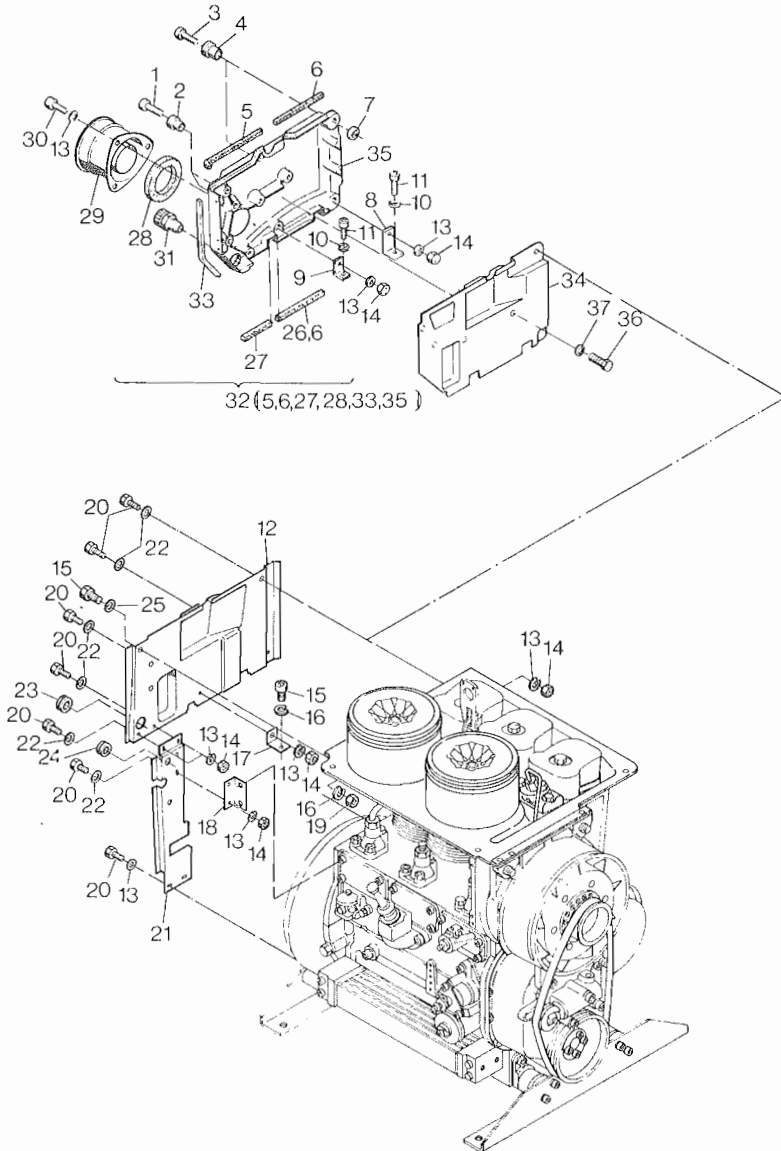

18

	Bestell-Nr.	Stück			Hinweise	
	Ordering No.	Quantity	3 L 30 S/Z	3 L 30 C	Hints	
	No. référence	Quantites			Indications	
	No. de pedido	Cantidades			Indicaciones	
			3 L 30 S/Z	3 L 30 C	3 M 40	
32	---	---	---	---	---	
33	---	---	---	---	---	
34	036 462 01	---	---	---	1	
35	---	---	---	---	---	
36	500 255 00	---	---	---	7	M 6 x 12 DIN 933-8.8
37	500 812 00	---	---	---	7	A 6 DIN 137

Tafel Nr.
Table No.
Tableau No.
Tabla No.

19

Kapsel C
Capsule C
Capsule C
Cápsula C

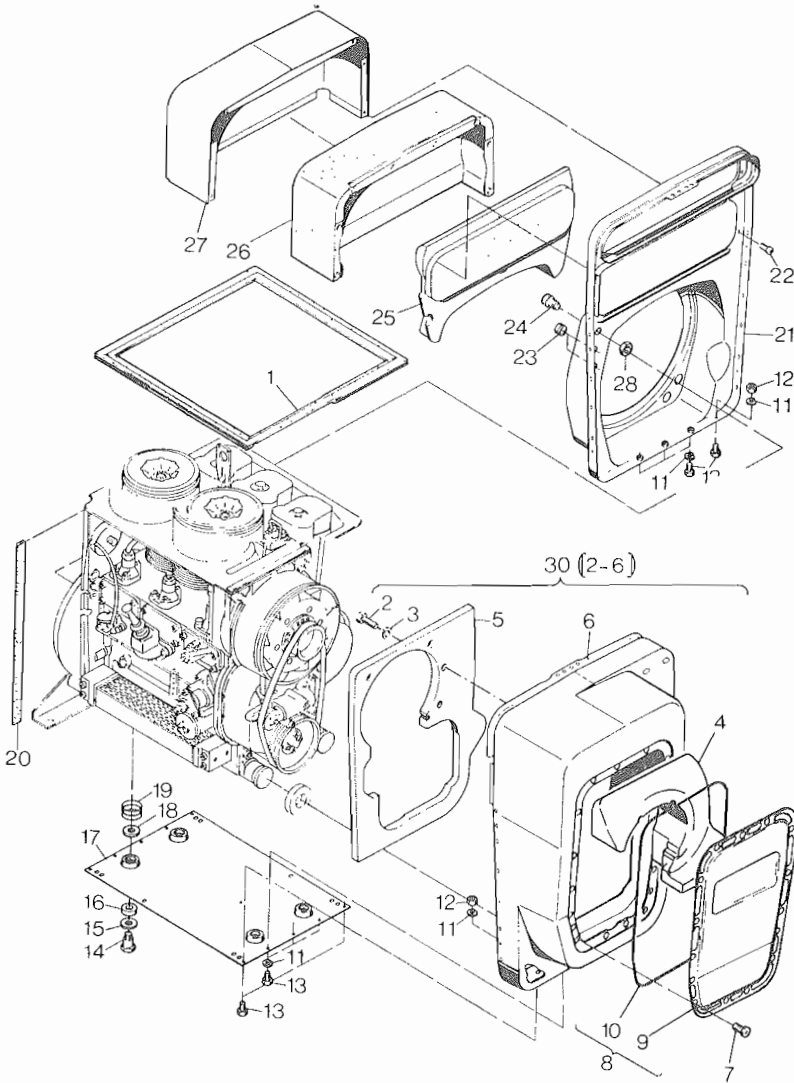

	Bestell-Nr. Ordering No. No. référence No. de pedido	Stück Quantity Quantités Cantidades	Hinweise Hints Indications Indicaciones	
3 L 30 C				
1	036 161 01	1		
2	500 266 00	2	M 8 x 12	DIN 933-8.8
3	500 028 00	2	B 8	DIN 137
4	009 958 00	1		
5	035 850 02	1		
6	—	—		
7	502 619 00	17	AM 6 x 10	DIN 7516-8.8 A3R
8	009 985 00	1		
9	—	—		
10	037 654 00	1		
11	500 812 00	10	A 6	DIN 137
12	500 227 00	4	M 6	DIN 934-8.8
13	500 254 00	10	M 6 x 10	DIN 933-8.8
14	035 950 00	4		
15	036 373 00	4		
16	036 372 00	4		
17	037 529 00	1		
18	035 952 00	4		
19	035 949 00	4		
20	035 862 01	1		
20	—	—		
21	009 501 00	1		
21	—	—		
22	501 383 00	8	M 6 x 10	DIN 7985-8.8
23	035 654 00	2		
24	501 590 10	1	NH 13,5	
25	035 872 02	1		
25	—	—		
26	035 879 01	1		
27	009 111 01	1		
28	501 591 00	1	PG 13,5	
29	—	—		
30	009 503 10	1		

Tafel Nr.
Table No.
Tableau No.
Tabla No.

20

Kapsel C
Capsule C
Capsule C
Cápsula C

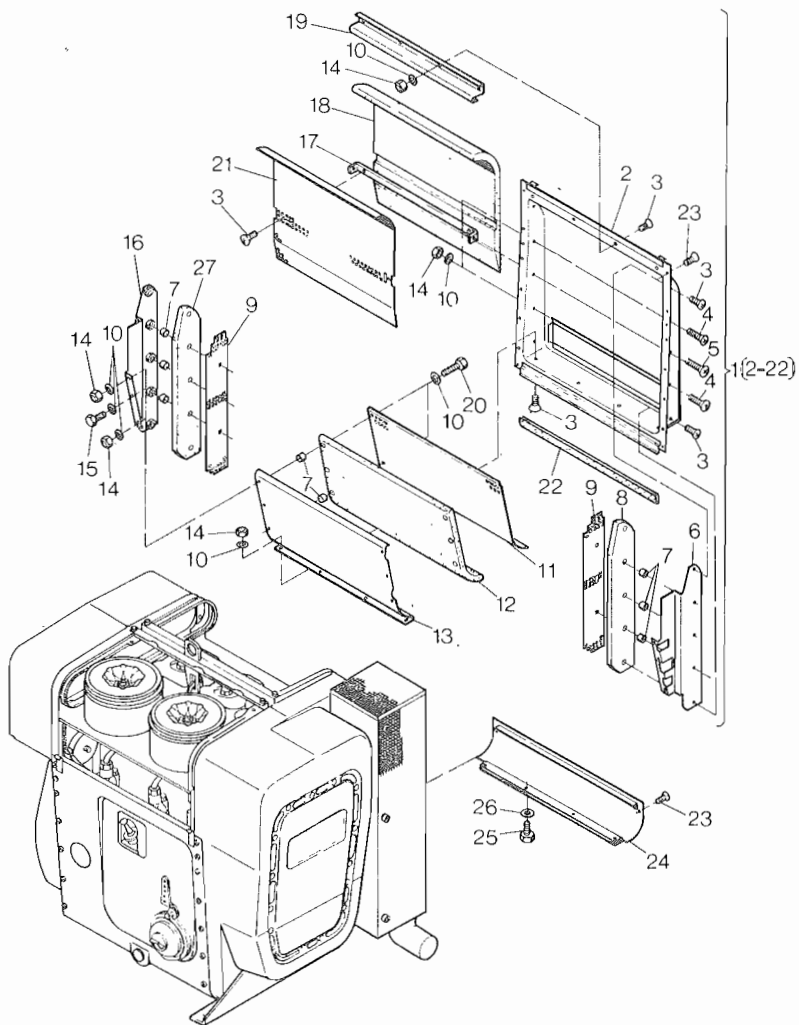

	Bestell-Nr. Ordering No. No. référence No. de pedido	Stück Quantity Quantities Cantidades	Hinweise Hints Indications Indicaciones	
3 L30 C				
1	009 257 01	1		
2	009 070 01	1		
3	501 383 00	13	M 6 x 10 DIN 7985-8.8 A3R	
4	501 385 00	4	M 6 x 30	DIN 7985-5.6
5	501 386 00	2	M 6 x 35	DIN 7985-5.6
6	009 084 01	1		
7	035 905 00	10		
8	035 871 01	1		
9	035 908 01	2		
10	500 166 00	24	6,4	DIN 125-St
11	035 912 00	1		
12	035 877 00	1		
13	009 081 00	1		
14	500 227 00	18	M 6	DIN 934-8
15	500 255 00	2	M 6 x 12	DIN 933-8.8
16	009 083 01	1		
17	035 913 00	1		
18	035 874 00	1		
19	035 848 00	1		
20	500 261 00	4	M 6 x 30	DIN 933-8.8
21	035 911 00	1		
22	035 934 00	1		
23	502 618 00	14	M 6 x 10 DIN 7985-8.8 A3R	
24	009 500 00	1		
25	500 254 00	4	M 6 x 10	DIN 933-8.8
26	500 166 00	4	6,4	DIN 125-St
27	037 504 01	1		

Table No.
21

21

Kapsel C
Capsule C
Capsule C
Cápsula C

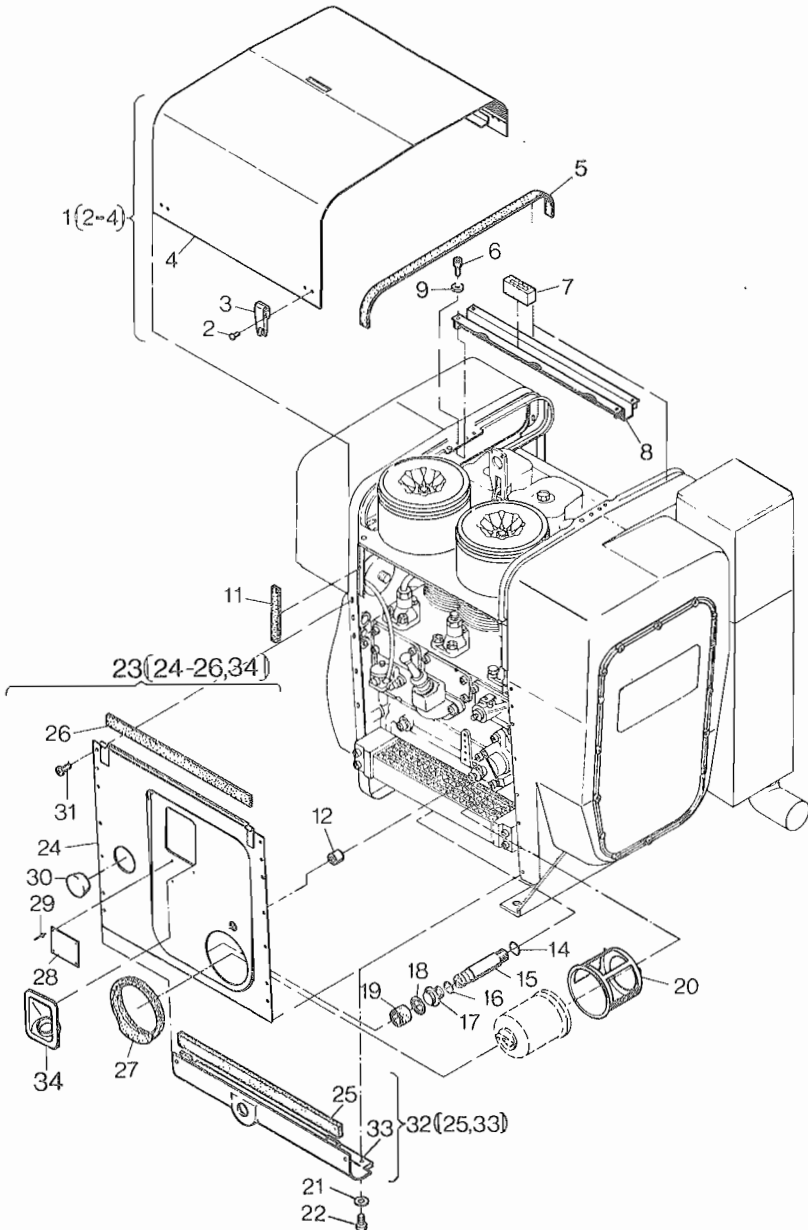

	Bestell-Nr. Ordering No. No. référence No. de pedido	Stück Quantity Quantités Cantidades	Hinweise Hints Indications Indicaciones
		3 L 30 C	
1	009 068 00	1	
2	502 373 00	8	5 x 10 DIN 660-USt 36-2
3	501 213 00	4	
4	—	—	
5	035 776 00	2	
6	501 330 00	4	M 6 x 12 DIN 6912-8.8
7	035 690 00	1	
8	035 826 00	1	
9	500 812 00	4	A 6 DIN 137
10	—	—	
11	035 772 00	2	
12	035 794 00	1	
13	—	—	
14	500 016 00	1	A 22 x 27 DIN 7603-Cu
15	035 505 00	1	
16	500 014 00	1	A 18 x 1,5 DIN 7603-Cu
17	500 442 00	1	M 18 x 1,5 DIN 910
18	035 923 00	1	
19	035 795 00	1	
20	009 243 00	1	
21	500 166 00	4	6,4 DIN 125-St
22	500 254 00	4	M 6 x 10 DIN 933-8.8
23	009 354 10	1	
24	—	—	
25	036 238 10	1	
26	035 934 00	1	
27	035 940 01	1	
28	036 396 00	1	
29	400 025 00	4	
30	037 693 00	1	
31	502 618 00	12	M 6 x 10 DIN 7985-8.8 A3R
32	009 739 00	1	
33	—	—	
34	037 614 00	1	

Tafel Nr.
Table No.
Tableau No.
Tabla No.

22

Kraftstoff
Fuel
Carburant
Combustible

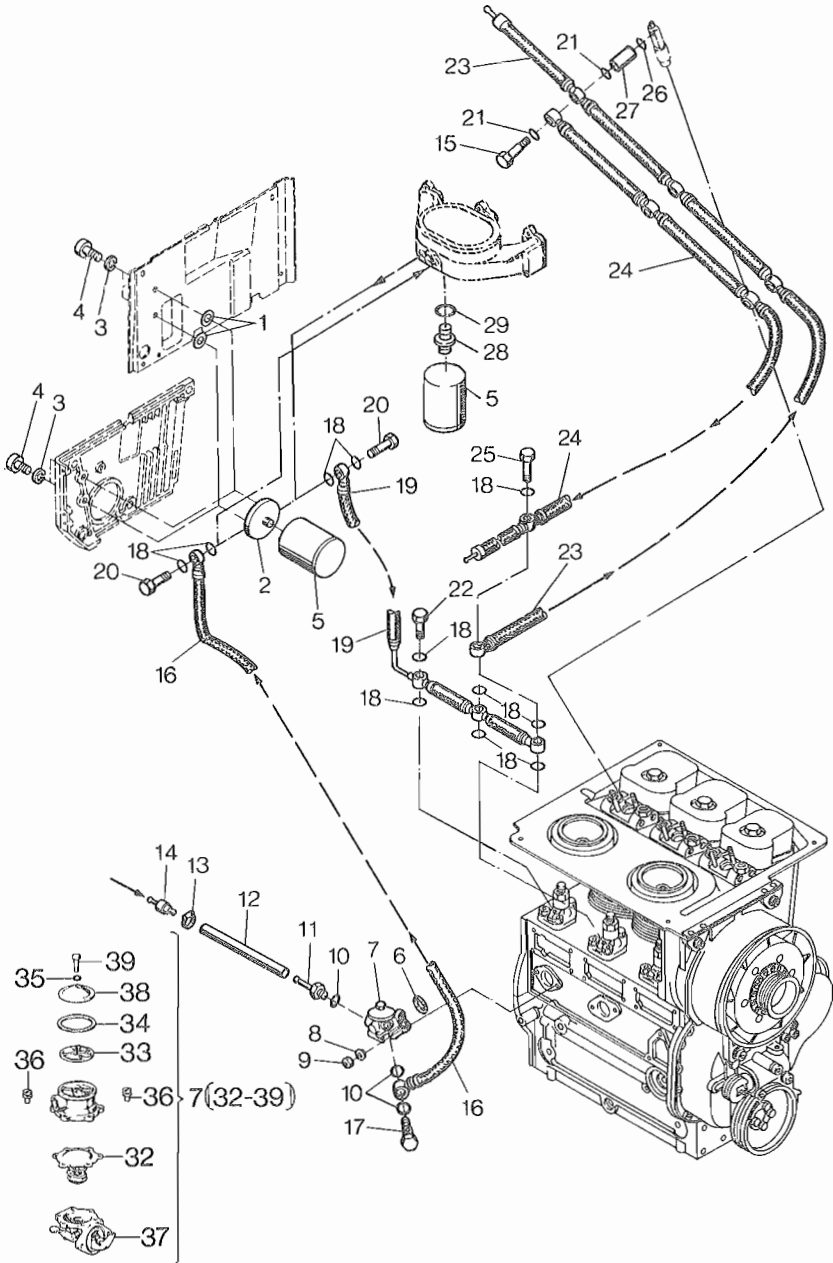

	Bestell-Nr. Ordering No. No. référence No. de pedido	Stück Quantity Quantités Cantidades			Hinweise Hints Indications Indicaciones
		3 L 30 S/Z	3 L 30 C	3 M 40	
1	501 230 00	—	2	—	
2	035 677 00	1	1	—	
3	500 028 00	2	2	—	8 DIN 128
4	500 516 00	2	2	—	M 8 x 16 DIN 912-8.8
5	401 203 00 W2	1	1	—	
5	502 515 00 W2	—	—	1	
6	501 299 00	1	1	1	
7	401 204 00	1	1	1	
8	500 812 00	2	2	2	A6 DIN 137
9	500 227 00	2	2	2	DIN 934-8
10	500 012 00	3	3	3	A 14 x 18 DIN 7603-Cu
11	034 668 00	1	1	1	
12	034 933 00	1	1	1	
13	400 373 00	1	1	1	
14	036 581 00	1	1	1	
15	034 602 00	3	3	3	
16	035 733 01	1	1	1	
17	500 064 00	1	1	1	A8 DIN 7623
18	500 011 00	11	11	11	A 12 x 15,5 DIN 7603-Cu
19	035 695 00	1	1	—	
19	038 366 00	—	—	1	
20	500 063 00	2	2	2	A6 DIN 7623
21	500 009 00	6	6	6	A 8 x 11,5 DIN 7603-Cu
22	036 134 00	2	2	2	
23	008 061 00	1	—	1	
24	008 024 00	—	1	—	
25	036 397 00	1	1	1	
26	500 008 00	3	3	3	A 6,5 x 9,5 DIN 7603-Cu
27	035 739 00	3	3	3	
28	502 533 00	—	—	1	A LL 10 DIN 7647
29	500 012 00	—	—	1	A 14 x 18 DIN 7603-Cu
32	490 182 00	1	1	1	
33	490 183 00	1	1	1	
34	490 184 00	1	1	1	
35	490 185 00	1	1	1	
36	490 181 00	6	6	6	
37	—	—	—	—	
38	—	—	—	—	
39	—	—	—	—	

Tafel Nr.
Table No.
Tableau No.
Tabla No.

23

Auspuff S/Z
Exhaust S/Z
Echappement S/Z
Escape S/Z

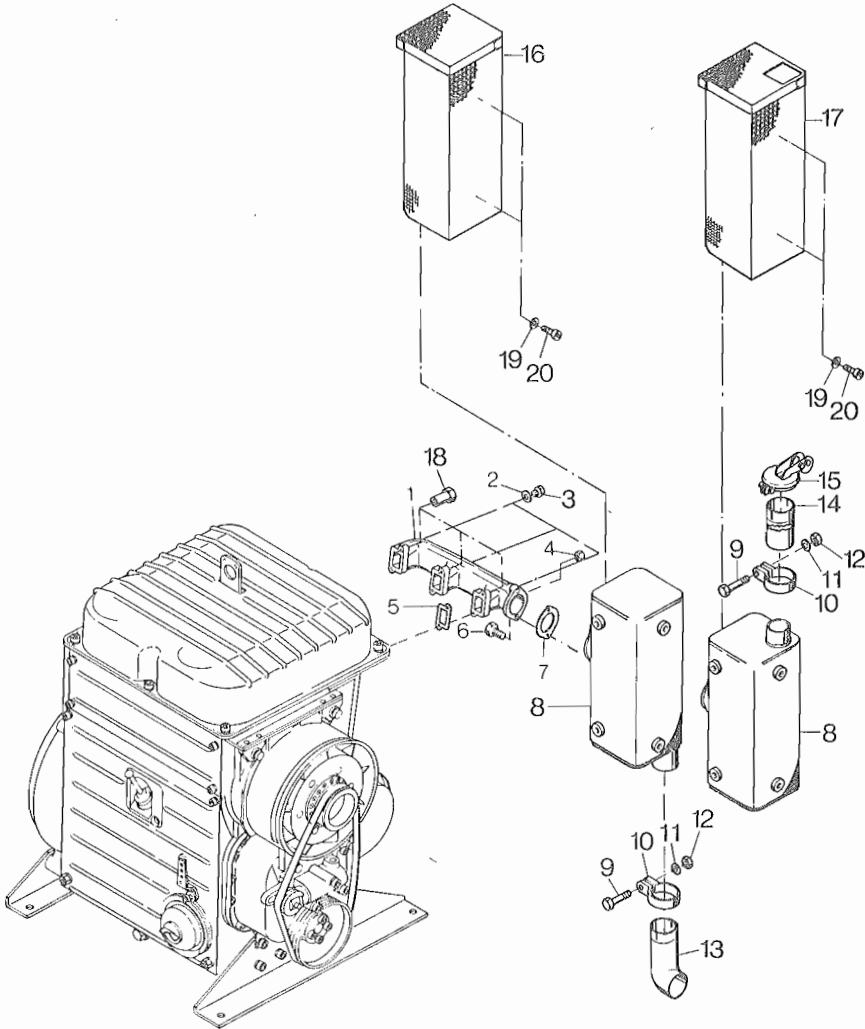

	Bestell-Nr.	Stück	Hinweise	
	Ordering No.	Quantity	Hints	
	No. référence	Quantités	Indications	
	No. de pedido	Cantidades	Indicaciones	
		3 L 30 S/Z	3 M 40	
1	035 520 00	1	—	
1	036 319 00	—	1	
2	032 288 00	3	3	
3	500 447 00	3	3	R 1/4 DIN 910
4	400 284 00	6	3	M 8 SSN 440-8 Cu
5	034 615 00	3	—	
5	036 245 00	—	3	
6	502 250 00	2	2	M 10 x 30 DIN 912-10.9 C4P
7	501 659 01	5	5	
8	011 091 00	1	1	
9	500 299 00	1	1	M 10 x 55 DIN 931-8.8
10	038 778 00	1	1	
11	500 169 00	1	1	10,5 DIN 125-St
12	400 286 00	1	1	M 10 SSN 440-8 Cu
13	038 856 00	1	1	
14	038 896 00	1	1	
15	501 569 00	1	1	
16	010 914 00	1	1	
17	038 858 00	1	1	
18	036 252 00	—	3	
19	501 200 00	6	6	A 6,4 DIN 9021-St A3C
20	501 390 00	6	6	M 6 x 10 DIN 912-8.8 C4P

Tafel Nr.
Table No.
Tableau No.
Tabla No.

24

Auspuff C
Exhaust C
Echappement C
Escape C

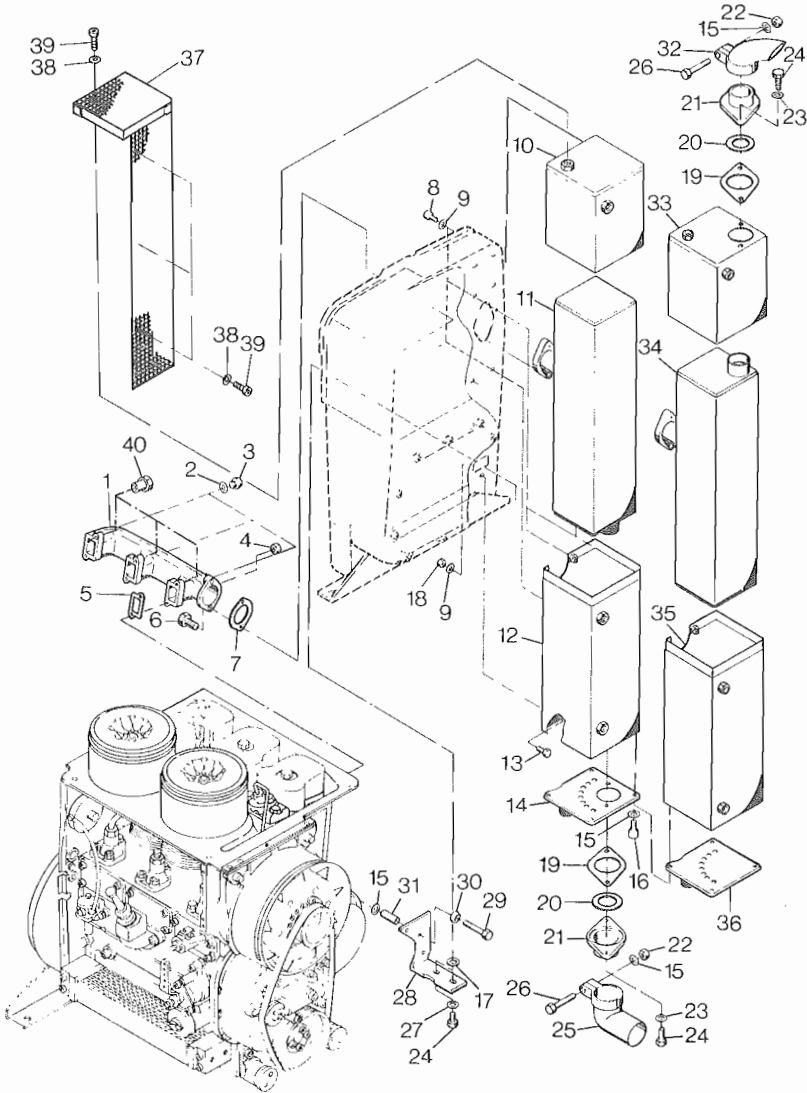

	Bestell-Nr. Ordering No. No. référence No. de pedido	Stück Quantity Quantités Cantidades	Hinweise Hints Indications Indicaciones	
3 L 30 C				
1	035 520 00	1		
2	032 288 00	3		
3	500 447 00	3	R 1/4	DIN 910
4	400 284 00	6	M 8	SSN 440-8 Cu
5	034 615 00	3		
6	501 433 00	2	M 10 x 35	DIN 933-8.8 C4P
7	501 659 01	5		
8	502 557 00	7	M 6 x 12	DIN 912-8.8 C4A
9	500 027 00	7	6	DIN 128
10	009 029 01	1		
11	037 093 00	1		
12	009 031 02	1		
13	500 255 00	1	M 6 x 12	DIN 933-8.8
14	009 032 02	1		
15	500 167 00	8	8,4	DIN 125-St
16	501 389 00	4	M 8 x 12	DIN 912-8.8
17	032 131 00	0...6		
18	500 227 00	1	M 6	DIN 934-8
19	036 288 00	1		
20	036 153 01	1		
21	036 287 00	1		
22	400 284 00	1	M 8	SSN 440-8 Cu
23	500 035 00	2	B 8	DIN 137
24	501 376 00	4	M 8 x 20	DIN 933-8.8 C4P
25	008 733 00	1		
26	500 284 00	1	M 8 x 60	DIN 931-8.8
27	500 629 00	2	B 8,4	DIN 9021-8.8
28	035 386 01	1		
29	500 879 00	3	M 8 x 70	DIN 931-8.8
30	500 028 00	3	8	DIN 128
31	035 387 01	3		
32	008 732 00	1		
33	008 715 01	1		
34	037 167 01	1		
35	008 718 01	1		
36	008 719 00	1		
37	008 492 00	1		
38	501 200 00	7	A 6,4	DIN 9021-St Zn
39	501 390 00	7	M 6 x 10	DIN 912-8.8 C4P

Tafel Nr.
Table No.
Tableau No.
Tabla No.

25

Starter, Generator
Starter, alternator
Demarreur, alternateur
Arrancador, alternador

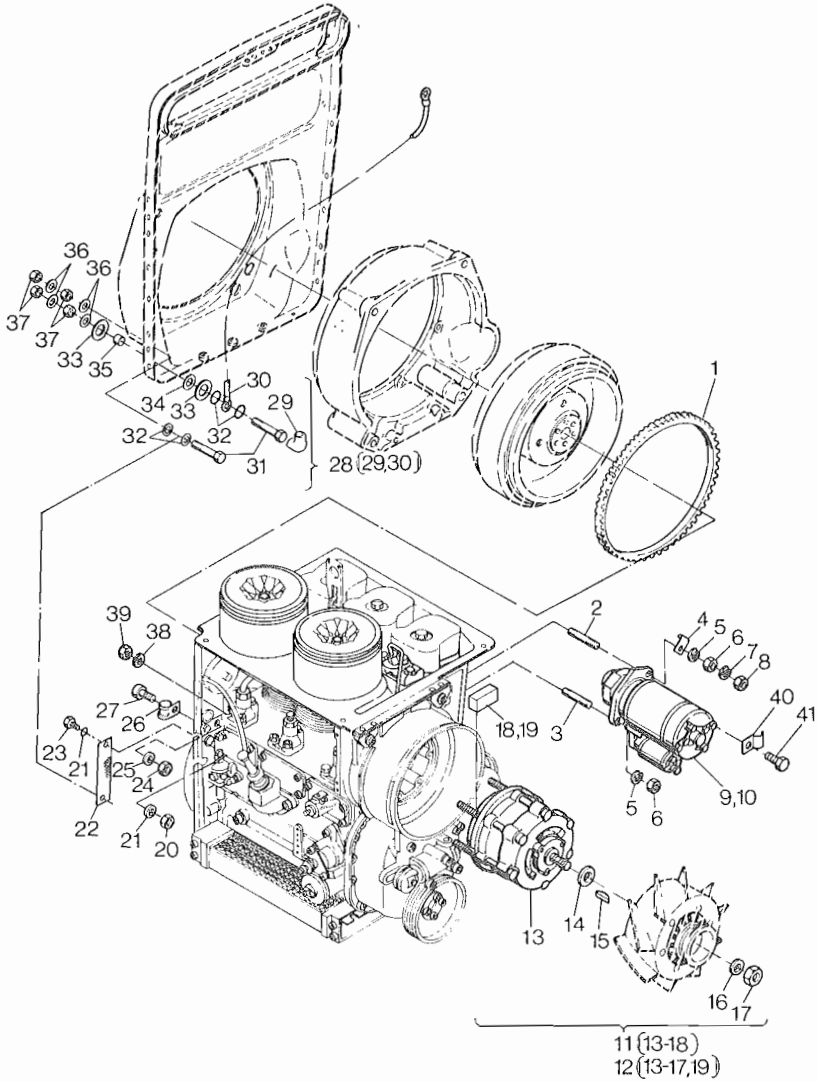

	Bestell-Nr. Ordering No. No. référence No. de pedido	Stück Quantity Quantités Cantidades	Hinweise Hints Indications Indicaciones	
		3 L 30 S/Z 3 M 40	3 L 30 C	
1	031 561 01	1	1	
2	032 868 00	1	1	M 12
3	500 423 00	1	1	
4	036 896 00	—	1	
5	500 030 00	2	2	M 12 DIN 128
6	500 239 00	2	2	
7	500 632 00	1	—	
8	500 635 00	1	—	
9	501 835 00	1	1	12 V 2,7 kW
10	501 954 00	1	1	24 V 4,0 kW
11	401 210 01	1	1	14 V 50 A
12	501 649 01	1	1	28 V 40 A
13	—	—	—	
14	—	—	—	
15	500 178 00	1	1	
16	—	—	—	
17	490 536 00	1	1	
18	490 538 00	1	1	12 V
19	490 539 00	1	1	24 V
20	501 480 00	—	1	M 8 DIN 934-8 A3C
21	501 481 00	—	2	8,4 DIN 125-St A3C
22	036 928 00	—	1	
23	500 985 00	—	1	M 8 x 16 DIN 933-8.8 A3C
24	501 444 00	—	2	M 6 DIN 934-8 A3C
25	500 812 00	—	2	A 6 DIN 137
26	501 584 00	—	2	
27	500 507 00	—	2	M 6 x 16 DIN 912-8.8
28	008 173 00	—	1	
29	400 266 00	—	1	
30	—	—	—	
31	500 274 00	—	2	M 8 x 30 DIN 933-MS
32	501 799 00	—	4	J 8,2 ZN DIN 6797
33	038 141 00	—	2	
34	501 798 00	—	1	A 10,5 ZN DIN 6797
35	038 142 00	—	1	
36	500 168 00	—	4	8,4 DIN 125-MS

Tafel Nr.
Table No.
Tableau No.
Tabla No.

25

Starter, Generator
Starter, alternator
Demarreur, alternateur
Arrancador, alternador

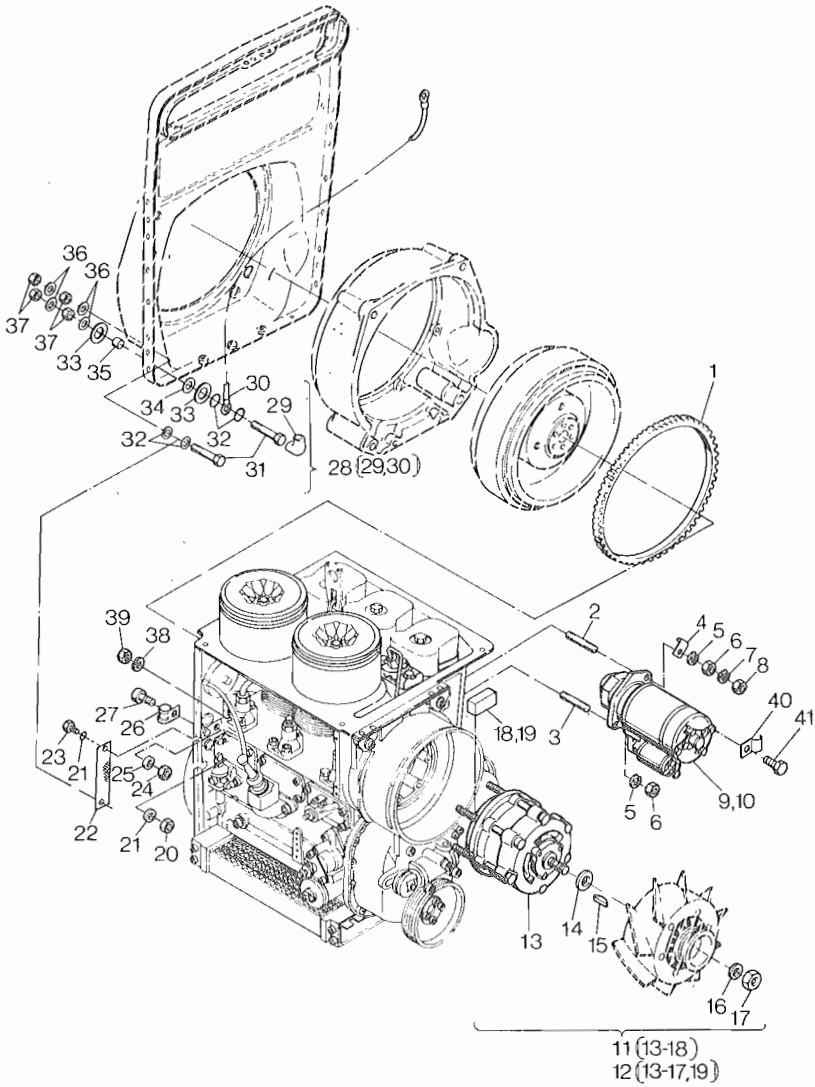

25

	Bestell-Nr.	Stück			Hinweise	
	Ordering No.	Quantity			Hints	
	No. référence	Quantités			Indications	
	No. de pedido	Cantidades			Indicaciones	
		3 L 30 S/Z	3 L 30 C			
		3 M 40				
37	500 230 00	—	4	M 8	DIN 934-MS	
38	500 812 00	6	6	A 6	DIN 137	
39	501 444 00	6	6	M 6	DIN 934-8 A3C	
40	501 584 00	1	1			
41	501 655 00	1	1	M 6 x 12	DIN 933-8.8 A3C	

Tafel Nr.
Table No.
Tableau No.
Tabla No.

26

Armaturen
Electric equipment
Équipement électrique
Equipo eléctrico

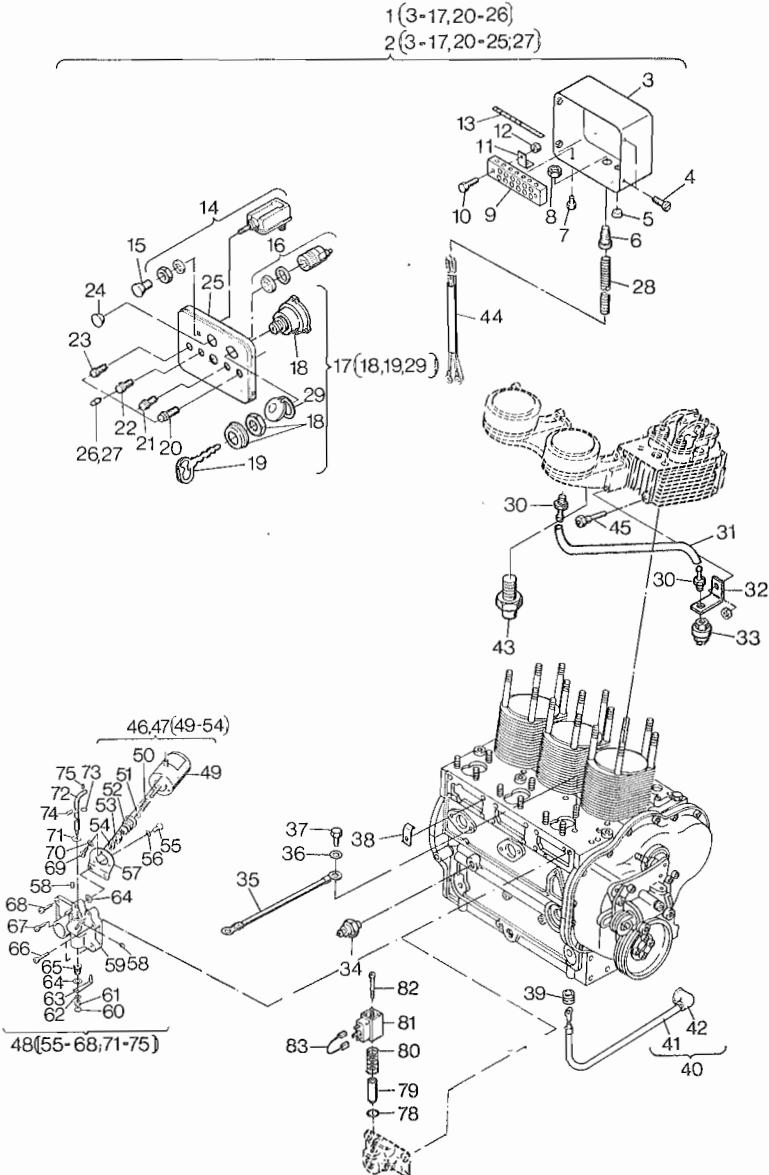

	Bestell-Nr. Ordering No. No. référence No. de pedido	Stück Quantity Quantites Cantidades			Hinweise Hints Indications Indicaciones
		3 L 30	3 M 40		
1	008 189 02	1	1		12 V
2	008 305 02	1	1		24 V
3	007 163 10	1	1		
4	501 383 00	4	4		M 6 x 10 DIN 7985-8.8
5	501 608 00	1	1		
6	501 590 10	1	1		
7	500 493 00	2	2		M 5 x 10 DIN 7985-4.8
8	501 591 00	1	1		
9	501 607 00	1	1		
10	501 588 00	2	2		M 4 x 20 DIN 84-5.8 A3C
11	036 667 00	2	2		
12	501 471 00	2	2		M 4 DIN 934-8 A3C
13	036 717 01	1	1		
14	502 765 00	1	1		
15	501 664 00 P1	1	1		
16	--	--	--		
17	--	--	--		
18	--	--	--		
19	400 686 00	1	1		
20	501 765 00	1	1		BATT
21	501 766 00	1	1		OIL
22	501 764 00	1	1		TEMP
23	501 824 00	1	1		FILTER
24	400 914 00	1	1		
25	035 092 11	1	1		
26	400 097 00	4	4		12 V, 2 W
27	400 098 00	4	4		24 V, 2 W
28	036 682 01	1	1		2000 mm
29	490 509 00	1	1		
30	501 677 00	2	2		
31	036 937 00	1	1		
32	036 936 00	1	1		
33	501 676 00	1	1		
34	400 213 00	1	1		OIL
35	008 171 00	1	1		
36	500 167 00	1	1		

Tafel Nr.
Table No.
Tableau No.
Tabla No.

26

Armaturen
Electric equipment
Équipement électrique
Equipo eléctrico

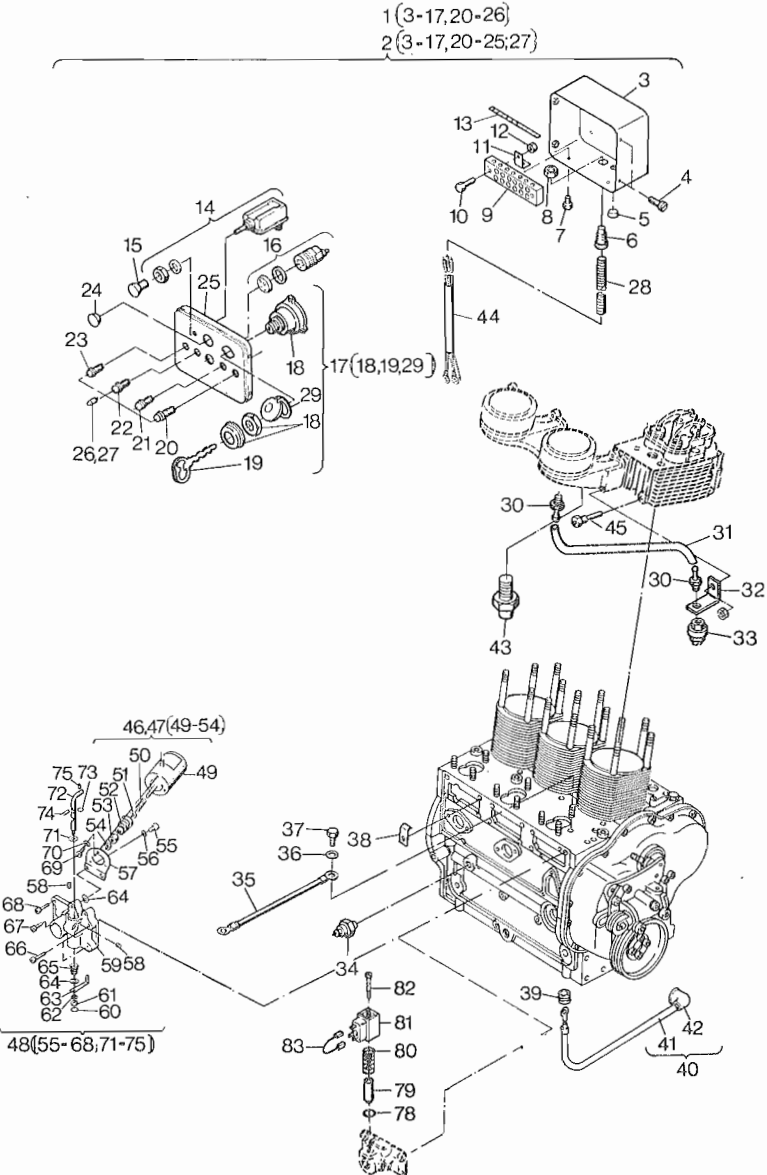

	Bestell-Nr. Ordering No. No. référence No. de pedido	Stück Quantity Quantites Cantidades		Hinweise Hints Indications Indicaciones	
		3 L 30	3 M 40		
37	500 267 00	1	1	M 8 x 16	DIN 933-8.8
38	036 666 00	2	2		
39	501 585 00	1	1		
40	008 206 01	1	1		
41	—	—	—		
42	400 266 00	1	1		
43	501 639 00	1	1		
44	008 187 01	1	1		
45	502 686 00	1	1	TEMP	
46	008 767 01	1	—	12 V	
47	008 768 01	1	—	24 V	
48	010 075 00	1	—		
49	—	—	—		
50	036 836 00	1	—		
51	500 166 00	1	—	6,4	DIN 125-St
52	501 804 00	1	—		
53	036 710 10	1	—		
54	500 227 00	1	—	M 6	DIN 934-8
55	500 519 00	2	—	M 8 x 20	DIN 912-8.8
56	500 028 00	2	—	8	DIN 128
57	036 707 10	1	—		
58	500 039 00	4	—	M 6 x 5	DIN 551-5.8
59	—	—	—		
60	500 430 00	1	—	16	DIN 443
61	400 282 00	1	—	M 5	SN 14440-5
62	500 165 00	1	—	5,3	DIN 125-St
63	036 702 00	1	—		
64	031 332 00	3	—		
65	031 744 02	1	—		
66	500 522 00	2	—	M 8 x 30	DIN 912-8.8
67	502 579 00	1	—	M 8 x 16	DIN 6912-8.8
68	400 808 00	1	—	M 8 x 20	DIN 912-8.8
69	500 492 00	3	—	M 4 x 10	DIN 84-4.8 Zn
70	500 164 00	3	—	4,3	DIN 125-St
71	032 131 00	1	—		
72	036 701 10	1	—		

Tafel Nr.
 Table No.
 Tableau No.
 Tabla No.

26

Armaturen
 Electric equipment
 Equipement électrique
 Equipo eléctrico

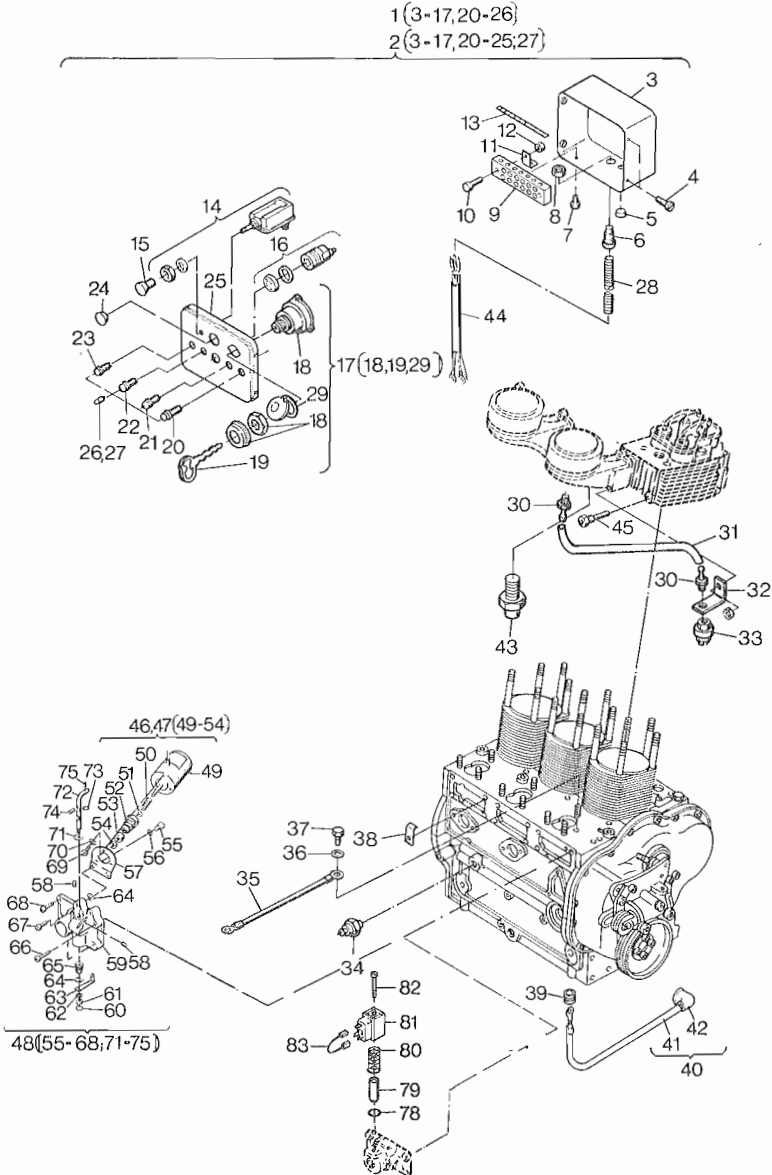

26

	Bestell-Nr.	Stück	Hinweise	
	Ordering No.	Quantity	Hints	
	No. référence	Quantities	Indications	
	No. de pedido	Cantidades	Indicaciones	
		3 L 30	3 M 40	
73	400 217 00	1	—	
74	501 255 00	1	—	
75	500 341 00	1	—	3 x 16 DIN 1481
78	502 750 00	—	1	14 x 1,78
79	038 976 00	—	1	
80	038 977 00	—	1	
81	038 668 01	—	1	12 V
81	038 669 01	—	1	24 V
82	502 669 00	—	2	M 4 x 35 DIN 912-8.8 A3C
83	—	—	—	

Tafel Nr.
Table No.
Tableau No.
Tabla No.

27

Motorfüße, Anschlußgehäuse, Keilriemenschutz
Engine bracket, intermediate housing, V-belt guard
Pieds moteur, bride raccord, protecteur courroie
Soportes del motor, caja de conexion, proteccion correa

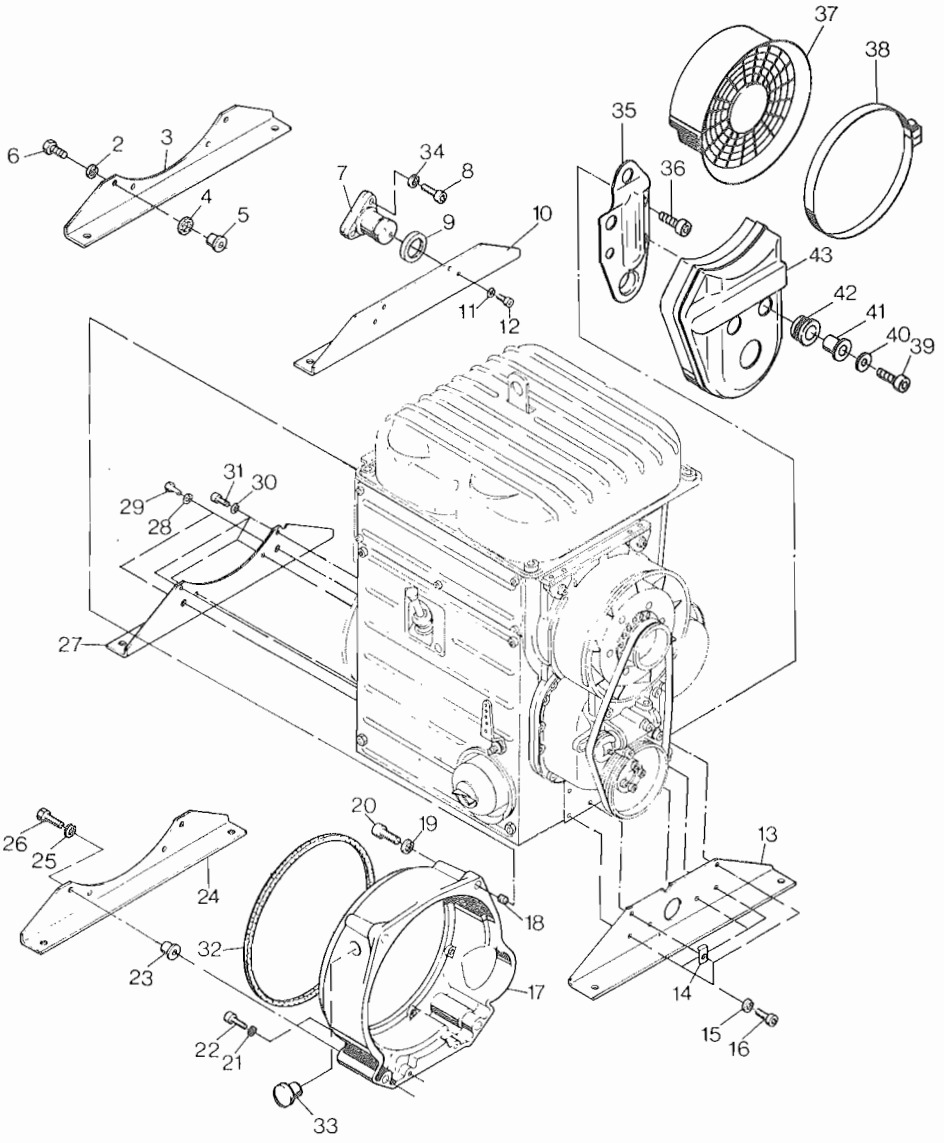

	Bestell-Nr. Ordering No. No. référence No. de pedido	Stück Quantity Quantités Cantidades		Hinweise Hints Indications Indicaciones
		3 L 30 S/Z 3 M 40	3 L 30 C	
1	—	—	—	
2	500 030 00	—	4	12 DIN 128
3	038 787 00	—	1	
4	035 798 00	—	4	
5	035 791 00	—	4	
6	502 593 00	—	4	M 12 x 110 DIN 931-8.8 A3C
7	007 393 01	—	2	
8	500 730 00	—	4	M 12 x 40 DIN 912-12.9
9	035 799 00	—	2	
10	038 789 00	—	1	
11	501 356 00	—	4	10 DIN 128 A3C
12	501 365 00	—	4	M 10 x 20 DIN 933-8.8 A3C
13	038 786 00	1	—	
14	036 696 00	1	—	
15	500 030 00	6	—	
16	500 311 00	6	—	M 12 x 28 DIN 933-8.8
17	035 759 02	1	1	SAE 5
18	501 374 00	4	4	18 x 18 DIN 7346
19	500 031 00	4	4	14 DIN 128
20	501 373 00	4	4	M 14 x 1,5 x 50 DIN 960-8.8
21	500 029 00	2	2	10 DIN 128
22	500 296 00	2	2	M 10 x 45 DIN 933-8.8
23	035 791 00	4	—	
24	038 787 00	1	—	
25	500 030 00	4	—	12 DIN 128
26	502 593 00	4	—	M 12 x 110 DIN 931-8.8 A3C
27	038 788 00	1	—	
28	500 031 00	2	—	14 DIN 128
29	500 875 00	2	—	M 14 x 1,5 x 30 DIN 933-8.8
30	500 029 00	4	—	10 DIN 128
31	500 292 00	4	—	M 10 x 25 DIN 933-8.8
32	035 929 01	—	1	
33	502 376 00	1	1	
34	034 693 00	—	4	
35	036 840 00	1	—	
36	500 530 00	3	—	M 8 x 70 DIN 912-8.8

Tafel Nr.
Table No.
Tableau No.
Tabla No.

27

Motorfüße, Anschlußgehäuse, Keilriemenschutz
Engine bracket, intermediate housing, V-belt guard
Pieds moteur, bride raccord, protecteur courroie
Soportes del motor, caja de conexion, proteccion corea

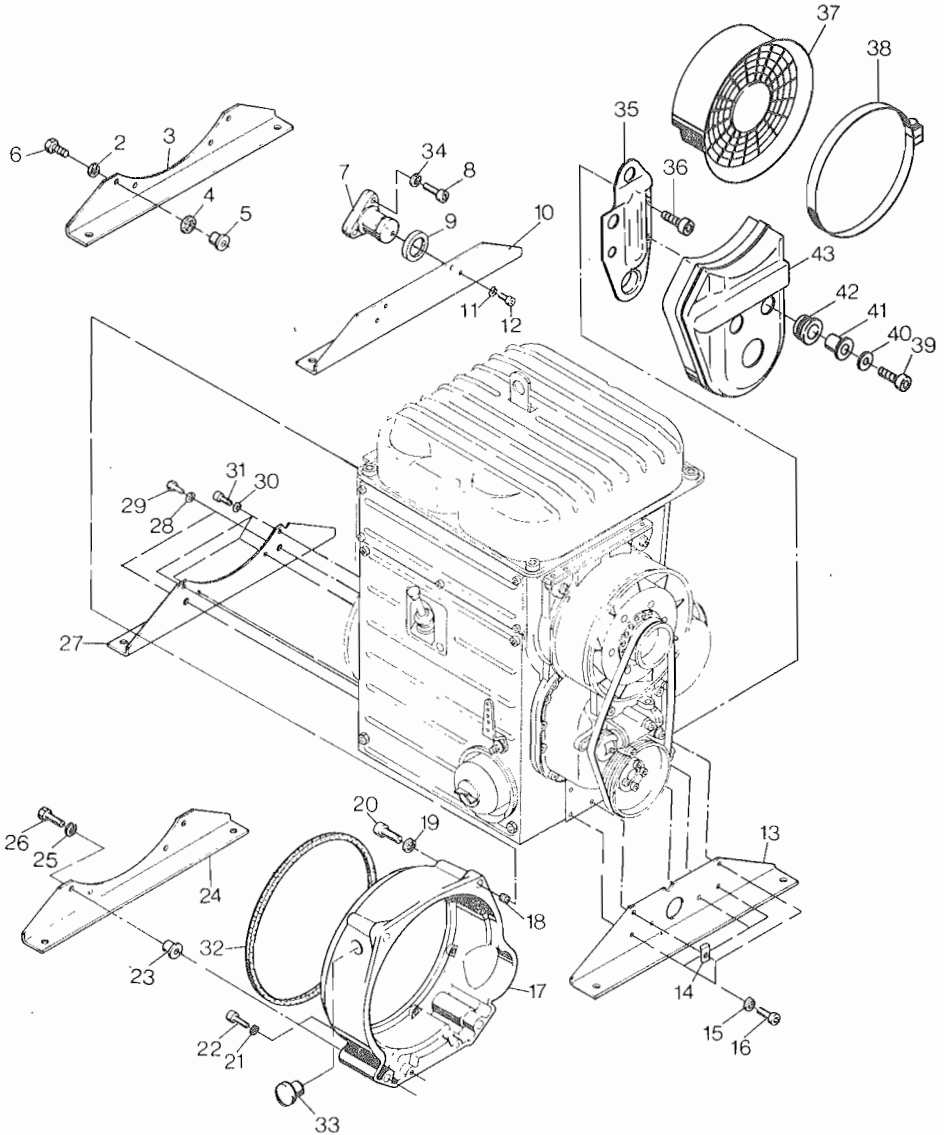

	Bestell-Nr.	Stück			Hinweise	
	Ordering No.	Quantity	3 L 30 S/Z	3 M 40	3 L 30 C	Hints
	No. référence	Quantites				Indications
	No. de pedido	Cantidades				Indicaciones
1	007 476 10	1	—	—		
1	007 476 11	—	1	—		$S > 2500 \text{ min}^{-1} / Z > 2000 \text{ min}^{-1}$
2	035 636 00	2	2	—		$n \geq 1500 \text{ min}^{-1}$
3	—	—	—	—		173 mm
4	035 637 01	1	1	—		215 mm
5	035 985 00	1	1	—		33 mm
6	035 638 00	1	1	—		67 mm
7	035 814 01	2	2	—		
8	501 304 00	2	2	2		
9	009 243 00	1	1	—		
10	034 657 00	1	1	1		
11	036 201 00	—	—	1		
12	500 812 00	—	—	2		A 6 DIN 137
13	500 255 00	—	—	2		M 6 x 12 DIN 933-8.3
14	035 689 00	—	—	1		
15	036 479 01	1	1	1		$S/Z \geq 1500 \text{ min}^{-1}$
16	500 035 00	4	4	4		B 8 DIN 137
17	502 041 00	2	2	4		M 8 x 95 DIN 6912-8.8
18	—	—	—	—		
19	007 437 10	1	1	—		
20	—	—	—	—		
21	—	—	—	—		
22	035 662 00	2	2	—		
23	035 794 00	1	1	—		
25	035 956 00	2	2	—		
24	500 229 00	4	4	—		M 8 DIN 934-8
26	035 755 00	2	2	—		
27	035 940 01	1	1	—		
28	009 214 00	2	2	—		
29	—	—	—	—		
31	—	—	—	—		
32	—	—	—	—		
33	035 689 00	1	1	—		
34	501 587 00	1	1	—		
35	008 157 10	1	—	—		f. Taf., Tabl. 26; Pos. 46-75
35	010 808 00	—	1	—		f. Taf., Tabl. 26; Pos. 76,77
36	—	—	—	—		
37	037 614 00	1	1	—		
38	500 009 00	1	—	1		A 8 x 11,5 DIN 7603-Cu
39	501 379 00	1	—	1		M 8 x 1 DIN 7604

Tafel Nr.
Table No.
Tableau No.
Tabla No.

29

Steuerdeckel für Hydraulik
Timing cover hydr.
Couvercle p. hydr.
Tapa de mando p. hidraulico

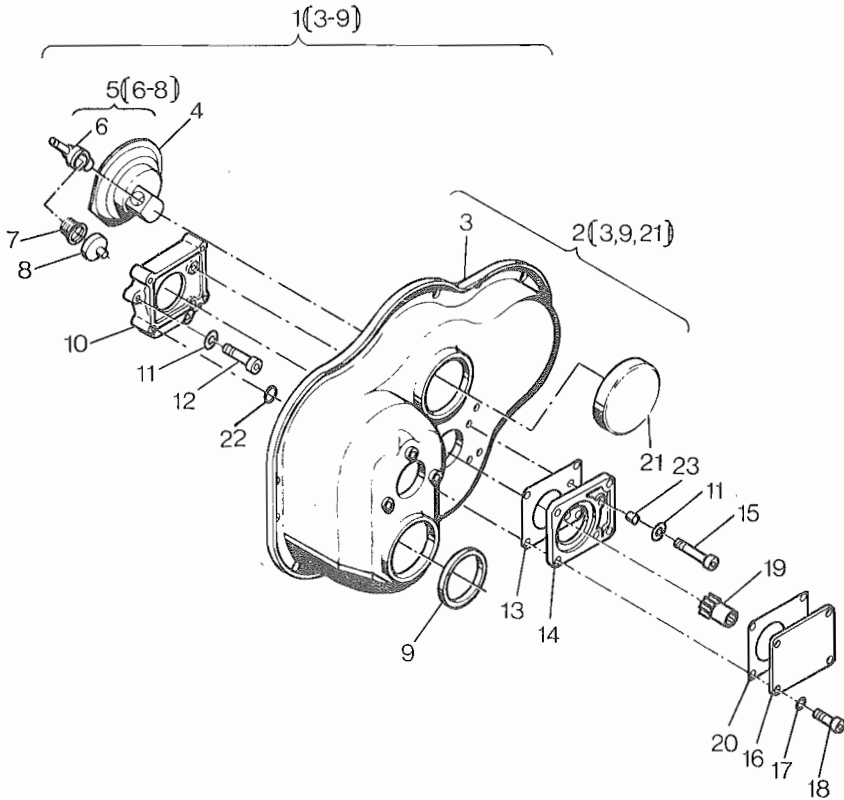

Bestell-Nr.
Ordering No.
No. référence
No. de pedido

Stück
Quantity
Quantities
Cantidades

Hinweise
Hints
Indications
Indicaciones

3 M40, 3 L 30

1	—	—		
2	009 935 00	1		
3	—	—		
4	—	—		
5	—	—		
6	—	—		
7	—	—		
8	—	—		
9	501 291 00	1		
10	037 543 00	1		
11	501 282 00	4	8	DIN 127
12	500 525 00	2	M 8 x 40	DIN 912-8.8
13	037 544 00	1		
14	035 550 11	1		
15	502 581 00	2	M 8 x 60	DIN 6912-8.8
16	037 616 00	1		
17	501 629 00	4	8 x 14	DIN 7603-Cu
18	502 688 00	4	M 8 x 30	DIN 912-8.8
19	010 623 00	1		
20	035 680 00	1		
21	501 265 00	1		DIN 442
22	400 223 00	2	8 x 12 x 2	
23	502 620 00	2	10 x 10	DIN 7346

Änderungsübersicht
Modification table
Aperçu de modifications
Tabla de modificaciones

Bildtafel Table Planche Tabla	Pos. No. Fig. No.	Bestell-Nr. Ordering No. No. référence No. de pedido	Stück Qty. Qté. Cant. C		Bildtafel Table Planche Tabla	Pos. No. Fig. No.	Bestell-Nr. Ordering No. No. référence No. de pedido	Stück Qty. Qté. Cant.	IMT NO.
3 L 30.16					3 L 30.17				84.433
13	6	501 407 00	3	≠	—	—	501 407 10	3	
07	43	034 685 01	2	=	—	—	034 685 01	1	
—	—	—	—	—	—	—	010 654 00	1	
02	8	501 122 00	9	=	—	—	501 122 00	8	
13	7	500 229 00	15	=	—	—	500 229 00	14	
—	—	—	—	—	—	—	038 622 00	1	
3 L 30.17					3 L 30.18				85.443
07	15	034 688 00	1	≠	07	15	034 688 10	1	
07	28	034 689 10	1	≠	07	28	034 689 20	1	
07	09	500 195 00	1	≠	07	09	500 350 00	1	
07	11	031 694 00	1	—	—	—	—	—	
07	12	031 696 00	1	—	—	—	—	—	
07	13	031 697 00	1	—	—	—	—	—	
07	14	031 698 00	1	—	—	—	—	—	
07	10	501 321 00	1	—	—	—	—	—	
07	25	502 243 00	1	—	—	—	—	—	
07	26	502 244 00	1	—	—	—	—	—	
3 L 30.18					3 L 30.19				85.444
11	02	009 561 00	1	≠	11	10	009 932 00	1	
29	01	009 476 10	1	≠	29	02	009 935 00	1	
15	18	036 233 00	1	≠	15	28	036 489 00	1	
11	21	036 230 00	1	≠	11	21	009 028 00	1	
11	22	036 231 00	1	≠	11	21	009 028 00	1	
11	04	036 228 01	1	—	—	—	—	—	
03	12	036 229 00	1	—	—	—	—	—	
03	14	500 251 00	4	—	—	—	—	—	
03	13	500 026 00	4	—	—	—	—	—	
15	09	035 961 02	1	≠	15	09	035 961 03	1	
15	17	036 232 00	1	—	—	—	—	—	
15	16	036 234 00	1	—	—	—	—	—	
15	21	500 442 00	1	—	—	—	—	—	
15	20	500 014 00	1	—	—	—	—	—	
15	03	009 047 00	2	≠	15	03	009 047 10	2	
15	07	035 978 00	2	—	—	—	—	—	
15	02	500 167 00	2	—	—	—	—	—	

27Bestell-Nr.
Ordering No.
No. référence
No. de pedidoStück
Quantity
Quantites
CantidadesHinweise
Hints
Indications
Indicaciones3 L 30 S/Z
3 M 40

3 L 30 C

37	036 839 00	1	—		
38	038 024 00	1	—		
39	501 706 00	2	—	M 6 x 20	DIN 912-8.8 A3C
40	501 143 00	2	—	6,4	DIN 7349 Zn
41	033 776 00	2	—		
42	036 652 00	2	—		
43	037 110 00	1	—		

Tafel Nr.
Table No.
Tableau No.
Tabla No.

28

Ölkühler
Oil cooler
Radiateur d'huile
Radiador de aceite

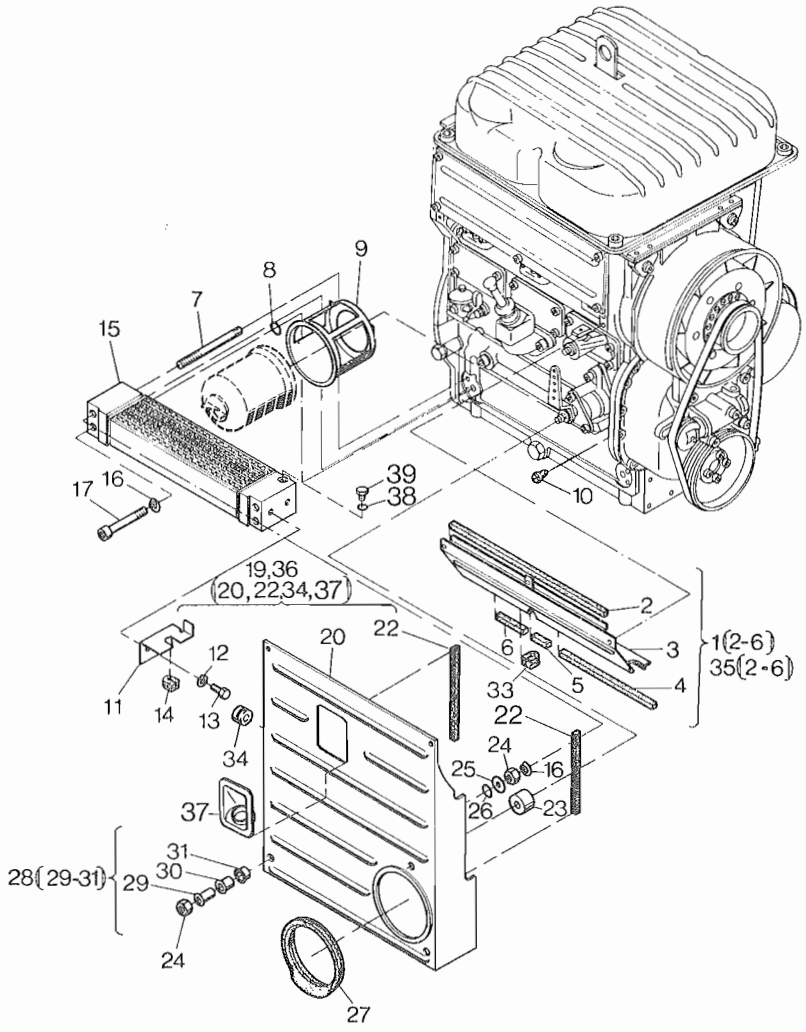

Änderungsübersicht
Modification table
Aperçu de modifications
Tabla de modificaciones

Bildtafel Table Planche Tabla	Pos. No. Fig. No. Fig. No. Fig. No.	Bestell-Nr. Ordering No. No. référence No. de pedido	Stück Qty. Qté. Cant. C		Bildtafel Table Planche Tabla	Pos. No. Fig. No. Fig. No. Fig. No.	Bestell-Nr. Ordering No. No. référence No. de pedido	Stück Qty. Qté. Cant.	IMT NO.
15	08	501 294 00	2		—	—	—	—	
15	01	501 295 00	2		—	—	—	—	
—	—	—	—		15	18	037 523 01	2	
28	19	007 437 03	1	≠	28	19	007 437 10	1	
28	36	008 153 01	1	≠	28	36	008 153 10	1	
17	11	007 428 02	1	≠	17	11	007 428 10	1	
28	01	007 476 02	1	≠	28	01	007 476 10	1	
28	35	008 157 00	1	≠	28	35	008 157 10	1	
17	11	008 158 00	1	≠	17	11	008 158 10	1	

Änderungsübersicht
Modification table
Aperçu de modifications
Tabla de modificaciones

Bildtafel Table Planche Tabla	Pos. No. Fig. No.	Bestell-Nr. Ordering No. No. référence No. de pedido	Stück Qty. Qté. Cant. C		Bildtafel Table Planche Tabla	Pos. No. Fig. No.	Bestell-Nr. Ordering No. No. référence No. de pedido	Stück Qty. Qté. Cant.	IMT NO.
3 M 40.10					3 M 40.11				84.433
13	06	502 368 00	3	≠	—	—	502 368 10	3	
07	43	034 685 01	2	=	—	—	034 685 01	1	
—	—	—	—	—	—	—	010 654 00	1	
02	08	501 122 00	9	=	—	—	501 122 00	8	
13	07	500 229 00	15	=	—	—	500 229 00	14	
—	—	—	—	—	—	—	038 622 00	1	
3 M 40.11					3 M 40.12				84.443
07	15	034 688 00	1	≠	07	15	034 688 10	1	
07	28	034 689 10	1	≠	07	28	034 689 20	1	
07	09	500 195 00	1	≠	07	09	500 350 00	1	
07	11	031 694 00	1	—	—	—	—	—	
07	12	031 696 00	1	—	—	—	—	—	
07	13	031 697 00	1	—	—	—	—	—	
07	14	031 698 00	1	—	—	—	—	—	
07	10	501 321 00	1	—	—	—	—	—	
07	25	502 243 00	1	—	—	—	—	—	
07	26	502 244 00	1	—	—	—	—	—	
3 M 40.12					3 M 40.13				85.445