

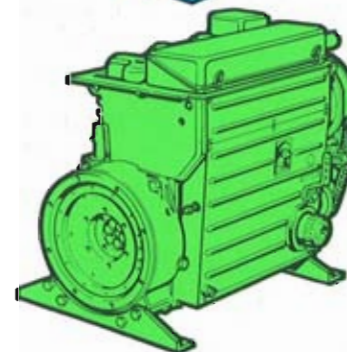

MOTORENFABRIK HATZ GMBH & CO KG · D-8399 RUHSTORF a. d. ROTT
TEL. (08531) 3021 · TELEX 57260

Ersatzteil-Liste
Spare parts list
Liste des pièces de rechange
Lista de recambios

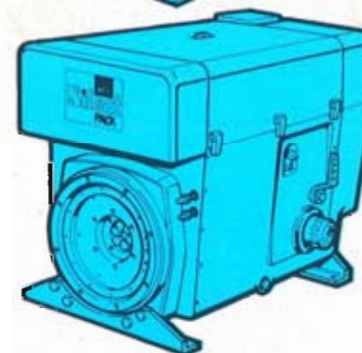
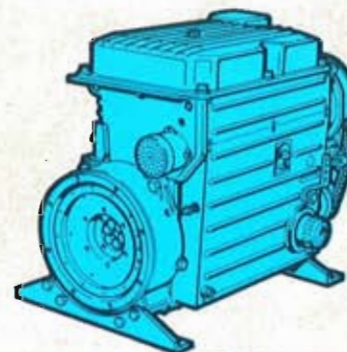

WICHTIG — Bitte Daten eintragen
IMPORTANT — Compléter les données

IMPORTANT — Please enter data
IMPORTANTE — Favor completar datos

Bitte hier **Type, Motornummer** und **Drehzahl** (siehe Motor-Typenschild) eintragen.

Enter here **type, engine no.** and **rpm.** (see engine type-plate).

Indiquer ici le **type, N° de moteur** et **régime** (voir plaque moteur).

Insertar aquí **tipo, N° motor** y **r.p.m.** (vea placa del motor).

+ MOTORENFABRIK HATZ ^{GMBH} KG +		
D-8399 RUHSTORF/ROTT		
TYPE	PV	NH
No		r/MIN
HATZ		
DIESEL		
MADE IN GERMANY (FED. REP.)		

1

Bitte **Ersatzteillistennummer** gemäß Type ankreuzen, z. B. Typ 4 L 30:

4 L 30.19

Mark **spare parts list no.** acc. to type, e. g. for type 4 L 30:

4 L 30.19

Cocher le **N° de liste de pièces de rechange** selon type, par. ex. 4 L 30:

4 L 30.19

Marcar **N° lista de recambios** de acuerdo aipo, ejemplo tipo 4 L 30:

4 L 30.19

Ersatzteilliste Nr.

Spare parts list no.

Liste de pièce de rechange no.

Lista de recambios no.

4 L 30.19 4 L 40.16 4 M 40.13

2

HATZ-Service

Bitte tragen Sie hier die **Anschrift** Ihrer nächsten HATZ-Service-stelle ein.

Insert here **address** of your next HATZ Service station.

Indiquer ici l'**adresse** de votre stationservice HATZ la plus proche.

Insertar aquí **dirección** de servicio HATZ más cercano.

3

MOTORENFABRIK HATZ
GmbH & Co. KG
D - 8399 RUHSTORF a. d. ROTT
Federal Republic of Germany
☎ (085 31) 30 21 — Telex 57260

Angaben bei Ersatzteilbestellungen:

Zur richtigen und schnellen Belieferung mit Ersatzteilen sind folgende Angaben erforderlich:

1. **Type, Motornummer** und **Drehzahl** des Motors, für den das Ersatzteil benötigt wird: siehe Angaben auf Seite 3, Feld 1.
2. **Nummer der Ersatzteilliste**, aus der die Bestellnummer herausgelesen wurde: siehe Seite 3, Feld 2.
3. **Stückzahl** und **Bestell-Nr.** des gewünschten Ersatzteils.
4. Gewünschte **Versandart**, z. B. Post, Luftfracht, Express.
5. Genaue **Versandadresse**, wenn erforderlich mit Post- u. Bahnstation.

Bestellbeispiel:

Für Motortype: 4 L 30 C - 154 b
Motornummer: 5319852212
1/min: 3000/60

aus Ersatzteil-Liste 4 L 30.19

folgende Teile:

Stück	Bestell-Nr.
2	500 526 00
8	500 812 00

per Postexpress an . . .

Die Ersatzteilbestellung richten Sie bitte an:

— die nächste HATZ-Servicestelle, Anschrift siehe Seite 3, Feld 3 oder separates Servicestellenverzeichnis

— oder an die

Motorenfabrik Hatz GmbH & Co. KG
D-8399 Ruhstorf a. d. Rott
Federal Republic of Germany
☎ (085 31) 3021 — Telex 57260

Particulars for spare parts orders:

The following information is needed to ensure correct and prompt supply of spare parts:

1. **Engine type, engine number** and **r.p.m.** of the engine for which you need the spare part.
See particulars on page 3, field 1.
2. **Number of spare parts list** from which you took the ordering no., see page 3, field 2.
3. **Quantity** and **ordering no.** of requested spare part.
4. Requested **mode of dispatch**, e. g. surface / airmail, airfreight, express.
5. Exact **shipping address**, if necessary indicate local post office and/or railway station.

Example for your order:

For engine type: 4 L 30 C - 154 b
Engine number: 5319852212
R. p. m.: 3000/60

Spare parts list no. 4 L 30.19

The following parts:

Qty.	ordering-no.
2	500 526 00
8	500 812 00

to be mailed, express, to . . .

Please address your spare parts order to:

— your nearest HATZ service station, address see page 3, field 3 or separate HATZ-service-list.

— or to

Motorenfabrik Hatz GmbH & Co. KG
D-8399 Ruhstorf a. d. Rott
Federal Republic of Germany
☎ (085 31) 3021 — Telex 57260

Données à indiquer lors de vos commandes de pièces détachées:

Pour nous permettre de livrer vos pièces rapidement et correctement, nous avons besoin des données suivantes:

1. **Type, No. et régime du moteur** pour lequel vous avez besoin de pièces: voir données page 3, carré 1.
2. **No de la liste de pièces de rechange** dans laquelle figure le No. de commande: voir page 3, carré 2.
3. **Quantité et No. de commande** de la pièce souhaitée.
4. **Mode d'expédition** souhaité: par ex. par poste, frêt aérien, exprès.
5. **Adresse exacte de destination** et, lorsque ceci est nécessaire, le nom de la poste et de la gare.

Exemple:

Pour type de moteur: 4 L 30 C - 154 b
No. moteur: 5319852212
Régime: 3000/60

Liste de pièces de rechange: 4 L 30.19

Les pièces suivantes:

Qté	No. commande
2	500 526 00
8	500 812 00

Par poste exprès à . . .

Les commandes de pièces détachées sont à adresser à:

— votre station-service HATZ la plus proche, voir adresse page 3, carré 3 ou liste de service séparée.

— ou

Motorenfabrik Hatz GmbH & Co. KG
D - 8399 Ruhstorf a. d. Rott
République Fédérale d'Allemagne
☎ (085 31) 30 21 — Telex 5 7260

Datos para pedidos de recambios:

Para recibir sus recambios en forma rápida y correcta necesitamos las siguientes informaciones:

1. **Tipo, número del motor y revoluciones:**
ver detalles en página 3, posición 1.
2. **Número de la lista de recambios** de la cual se ha obtenido el número de pedido: ver página 3, posición 2.
3. **Cantidad y número de pedido del recambio deseado.**
4. Tipo de **despacho deseado:** por ej. correo, flete aéreo, expreso etc.
5. **Dirección** exacta, si necesario indicar la oficina de correo, la estación ferroviaria o aeropuerto.

Ejemplo de pedido:

Para motor tipo: 4 L 30 C - 154 b
Número de motor: 5319852212
R. P. M.: 3000/60

De la lista de recambios: 4 L 30.19

Siguientes recambios:

Cantidad	Número de pedido
2	500 526 00
8	500 812 00

Por correo expreso para . . .

El pedido de recambios favor dirigirlo a:

— Al servicio HATZ más cercano, dirección verla en página 3, posición 3 o en el índice separado de direcciones de servicio.

— Alternativa a:

Motorenfabrik Hatz GmbH & Co. KG
D - 8399 Ruhstorf a. d. Rott
República Federal de Alemania
☎ (085 31) 30 21 — Telex 5 7260

	Inhaltsverzeichnis:	Index:	Tafel No Table No
M...	Grundmotor	Basic engine	
00, 34	Ersatzteilsätze, Zubehör	Spare parts kits, accessories	01
01	Kurbelgehäuse	Crankcase	02+03
01	Massenausgleich	Compensation of masses	04
02, 03	Kurbelwelle	Crankshaft	05
04	Nockenw., Regler, Spritzversteller	Camshaft, governor, timer	06
32	Drehzahlverstellung	Speed control	07
05, 06	Pleuelstange, Kolben, Zylinder	Conrod, piston, cylinder	08
07	Zylinderkopf	Cylinder head	09
09, 10	Stoßstange, Ölpumpe	Pushrod, oil pump	10
11, 12	Steuerdeckel, Startfüllung	Timing cover, extra fuel device	11
13	Gebälse	Blower	12
14	Einspritzausrüstung	Injection equipment	13
16 - 20	Riemenscheibe, Schwungrad, Hydr. Abstellvorrichtung	Pulley, flywheel, hydr. belt tensioner	14
22, 27	Luftfilter, Luftansaugrohr	Air filter, air intake manifold	15
26	Luftführung	Air ducting	16
26	Luftführung S/Z	Air ducting S/Z	17
26	Luftführung	Air ducting	18
35	Kapsel C	Capsule C	19+22
35	Kapsel - Abluftschacht 4 L 30 C/K	Capsule - air ducting 4 L 30 C/K	20
35	Kapsel - Abluftschacht 4 L 40 C/K	Capsule - air ducting 4 L 40 C/K	21
A...	Zusatzausrüstung	Equipements	
01	Kraftstoff	Fuel	23
03	Auspuff S/Z	Exhaust S/Z	24
03	Auspuff C	Exhaust C	25
05	Starter, Generator	Starter, alternator	26
05, 10	Armaturen	Electric equipment	27
06, 15 12	Motorfüße, Anschlußgehäuse, Keilriemenschutz S	Engine bracket, intermediate housing V-belt guard	28
07	Ölkühler	Oil cooler	29
18	Steuerdeckel f. Hydraulik	Timing cover hydr.	30
			Seite/Page
	Serien-Nr.-Änderungen	Serial-code modification list	108 - 110

	Sommaire:	Indice:	
A...	Moteur de base	Motor de base	
0, 34	Lots de pièces de rechange, accessoires	Juegos de piezas de recambios, accesorios	01
01	Carter moteur	Caja cigueñal	02+03
01	Equilibrage	Compensación de las masas	04
02	Vilebrequin	Cigüeñal	05
04	Arbre à cames, regulateur, avance variable du point d'injection	Arbol de levas, regulador, variador de avance	06
02	Reglage regime	Adjuste de revoluciones	07
05, 06	Bielle, piston, cylindre	Biela, émbolo, cilindro	08
07	Culasse	Culata	09
09, 10	Tige de culbuteur, pompe a huile	Varilla de balancín, bomba de aceite	10
11, 12	Couvercle distribut, surcharge	Tapa de mando, sobre alimentación-arranque	11
13	Soufflerie	Ventilador	12
14	Equipement d'injection	Equipo de inyección	13
16-20	Pouille, volant, tendeur hydr.	Polea, volante, tensor hidráulico	14
22, 27	Filtre à air, pipe d'admission	Filtro de aire, tubo de conducción	15
26	Carter ventilation	Conducción de aire	16
26	Carter ventilation S/Z	Conducción de aire S/Z	17
26	Carter entilation	Conducción de aire	18
35	Capsule C	Cápsula C	19+22
35	Capsule - carter ventilation 4 L 30 C/K	Capsula - chapa de aire 4 L 30 C/K	20
35	Capsule - carter ventilation 4 L 40 C/K	Capsula - chapa de aire 4 L 40 C/K	21
A...	Accessoires	Equipos	
01	Carburant	Combustible	23
03	Echappement S/Z	Escape S/Z	24
03	Echappement C	Escape C	25
05	Demarreur, alternateur	Arrancador, alternador	26
05, 10	Equipement électrique	Equipo eléctrico	27
06, 15	Pieds moteur, bride raccord, protecteur courroie	Soportes del motor, caja de conexión, revestimiento	28
07	Refroidisseur huile	Radiador de aceite	29
18	Tige de culbuteur hydr.	Varilla de balancin hidraulico	30

Tafel Nr.
Table No.
Tableau No.
Tabla No.

01

Ersatzteilsätze, Zubehör
Spare parts kits, accessories
Lots de pièces de rechange, accessoires
Juegos de piezas de recambios, accesorios

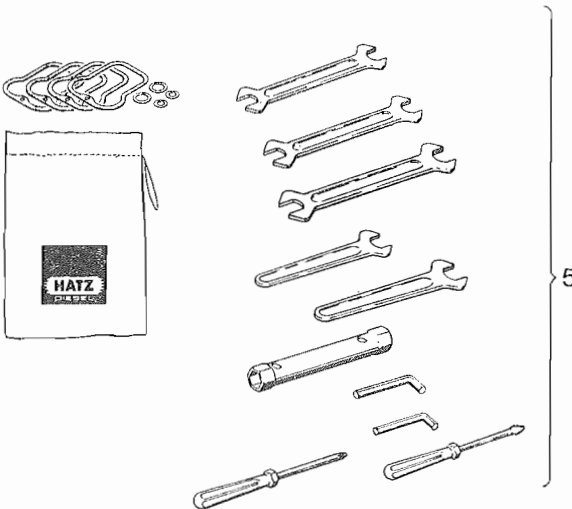
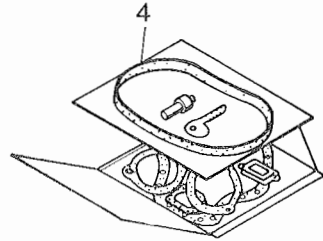
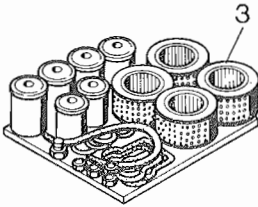
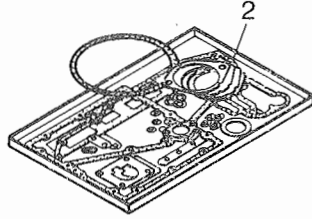
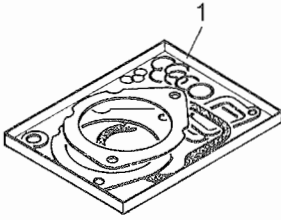

01

Bestell-Nr. Ordering No. No. référence No. de pedido	Stück Quantity Quantités Cantidades					Hinweis Hints Indications Indicaciones
---	--	--	--	--	--	---

		4 L30 S/Z	4L30 C/K	4 M 40 4L40 S/Z	4 L40 C/K	
1	009 919 00 P1	1	1	—	—	Dichtungssatz für 1 Zylinderkopf
1	009 922 00 P1	—	—	1	1	Joint set for 1 cyl. head Jeu de joint p. 1 culasse Juego de juntas para 1 culata
2	009 338 01	1	1	—	—	Dichtungssatz o. Wellendichtring
2	012 032 00	—	—	1	1	Joint set without oil seals Jeu de joints sans ann. etanch. Juego de juntas sin anillo de reten
3	009 622 00	1	1	—	—	Wartungssatz für 1000 h
3	012 032 01	—	—	1	1	1000 hours maintenance kit Kit d'entretien 1000 heures Juego de piezas para servicio 1000 horas
4	009 674 02	1	1	—	—	Pannensatz
4	009 872 01	—	—	1	1	Emergency kit Juego para averias
5	009 383 00	1	1	—	—	Zubehörsatz
5	009 383 01	—	—	1	1	Accessories kit Sort. accessoires Juego de accesorios

Wartungssatz: Einzelteile und Anzahl siehe W... neben Ident-Nr.

Pannensatz: Einzelteile und Anzahl siehe P... neben Ident-Nr.

Maintenance kit: Component parts and quantity see W... besides the Ident-No.

Emergency kit: Component parts and quantity see P... besides the Ident-No.

Kit d'entretien: Pièces composantes et quantité voir W... à côté du No. ident

Kit de secours: Pièces composantes et quantité voir P... à côté du No. ident

Juego de piezas para servicio: Piezas unitarias y cantidad ver W... lado No. ident

Juego para averias: Piezas unitarias y cantidad ver P... lado No. ident

Tafel Nr.
Table No.
Tableau No.
Tabla No.

02

Kurbelgehäuse
Crankcase
Carter moteur
Caja cigueñal

2(4- 31,38)
3(4-15,17-31,38)

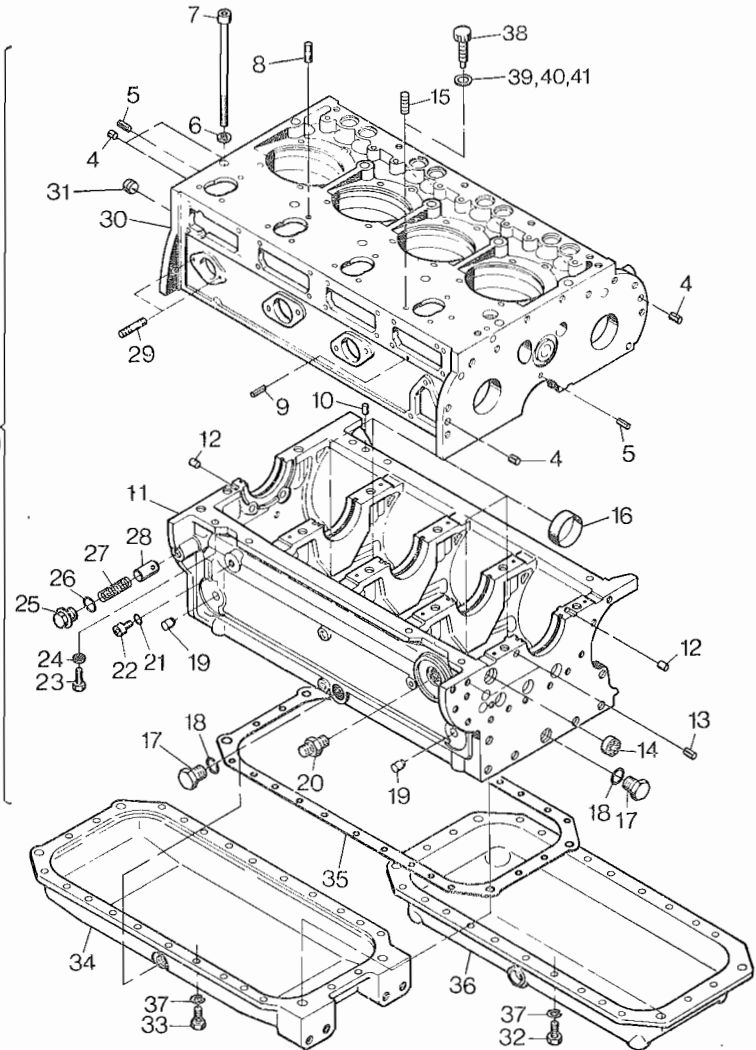

	Bestell-Nr. Ordering No. No. référence No. de pedido	Stück Quantity Quantites Cantidades					Hinweis Hints Indications Indicaciones	
		4L30S/K	4L40S/K	4L30C/Z	4L40C/Z	4M40		
1	—	—	—	—	—	—		
2	009 540 00	1	—	—	—	—		
2	012 009 00	—	1	—	—	—		
3	009 543 00	—	—	1	—	—		
3	012 021 00	—	—	—	1	—		
4	501 400 00	4	4	4	4	4	8 x 8	DIN 7346
5	501 305 00	2	2	2	2	2	5 x 24	DIN 1481
6	034 693 00	10	10	10	10	10		
7	501 259 00	10	10	10	10	10	M 12x1,5x190	DIN 912-10.9
8	501 122 00	11	11	11	11	11	M 8 x 18	DIN 939-10.9
9	501 305 00	1	1	1	1	1	5 x 24	DIN 1481
10	036 353 00	1	1	1	1	1		
11	—	—	—	—	—	—		
12	501 314 00	2	2	2	2	2	10 m 6 x 14	DIN 7-St 50K
13	508 849 00	2	2	2	2	2	8 x 12	DIN 7346
14	501 302 00	1	1	1	1	1		
15	038 636 00	—	1	—	1	1		
16	036 271 00	4	4	—	—	4		
17	501 404 00 W1	2	2	2	2	2	AM 22 x 1,5	DIN 7604
18	500 016 00 W4	2	2	2	2	2	A 22 x 27	DIN 7603-Cu
19	036 457 00	2	—	—	—	—	„S“/n ≤ 1500 min ⁻¹	
20	400 654 00	1	1	1	1	1		
21	500 624 00	1	1	1	1	1	A 10 x 13,5	DIN 7603-Cu
22	500 623 00	1	1	1	1	1	M 10 x 1	DIN 908
23	500 268 00	17	17	17	17	17	8 x 20	DIN 933-8.8
24	500 028 00	17	17	17	17	17	8	DIN 128
25	032 493 00	1	1	1	1	1		
26	500 014 00 W4	1	1	1	1	1	A 18 x 22	DIN 7603-Cu
27	036 399 00	1	1	1	1	1		
28	036 398 00	1	1	1	1	1		
29	501 392 00	2	2	2	2	2	M 6 x 16	DIN 939-8.8
30	—	—	—	—	—	—		
31	500 438 00	1	1	—	—	1		

Tafel Nr.
Table No.
Tableau No.
Tabla No.

02

Kurbelgehäuse
Crankcase
Carter moteur
Caja cigueñal

2(4-31,38)
3(4-15,17-31,38)

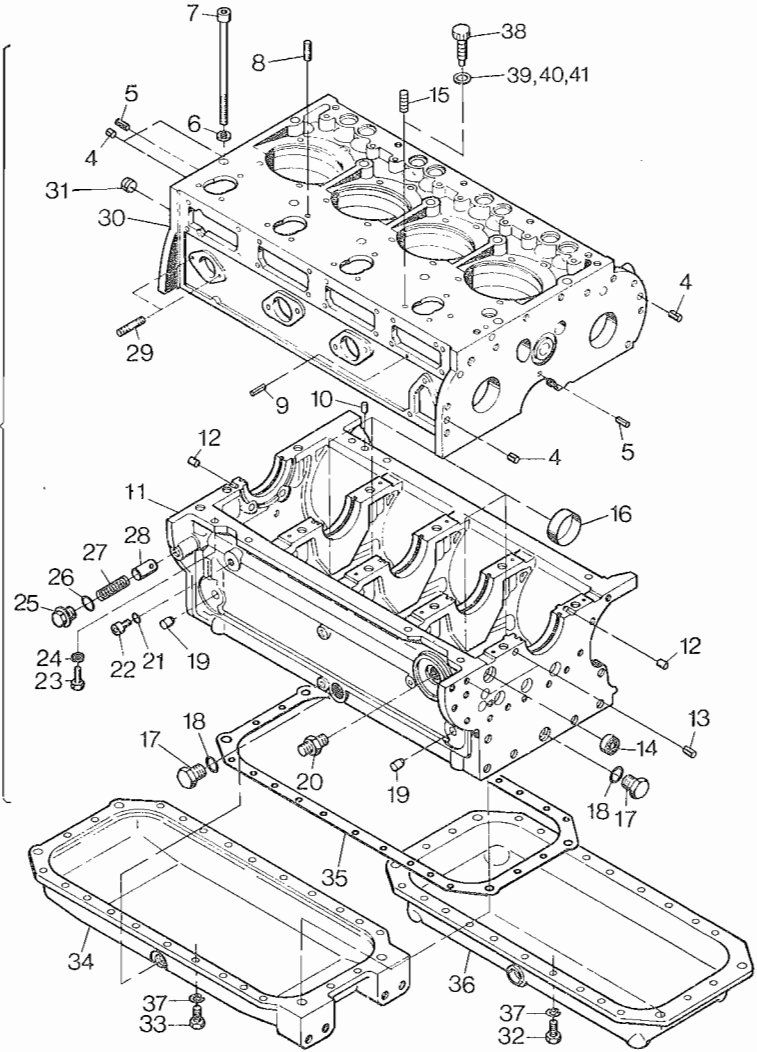

	Bestell-Nr. Ordering No. No. référence No. de pedido	Stück Quantity Quantites Cantidades					Hinweis Hints Indications Indicaciones	
		4 L30 S/K	4 L40 S/K	4 L30 C/Z	4 L40 C/Z	4 M 40		
32	500 267 00	24	24	24	24	24	M 8 x 16	DIN 933-8.8
33	500 270 00	24	24	24	24	24	M 8 x 25	DIN 933-8.8
34	036 007 01	1	1	1	1	1		
35	035 995 00	1	1	1	1	1		
36	009 177 01	1	1	1	1	1		
37	500 028 00	24	24	24	24	24	8	DIN 128
38	038 622 00	1	—	1	—	—		
39	032 130 00	1	—	1	—	—	0,3 mm	
40	032 131 00	1	—	1	—	—	0,5 mm	
41	032 132 00	1	1	1	1	—	1,0 mm	

Tafel Nr.
Table No.
Tableau No.
Tabla No.

03

Kurbelgehäuse
Crankcase
Carter moteur
Caja cigueñal

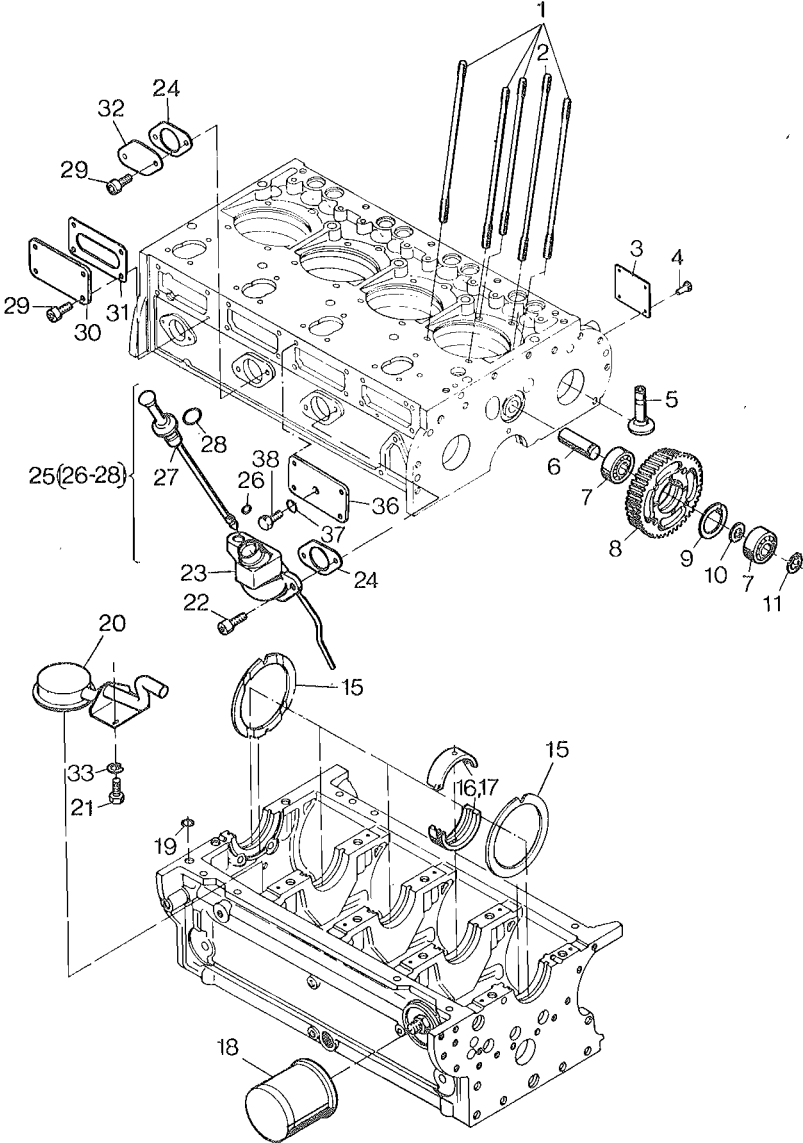

	Bestell-Nr.	Stück	Hinweis	
	Ordering No.	Quantity	Hints	
	No. référence	Quantites	Indications	
	No. de pedido	Cantidades	Indicaciones	
			4 M 40	
		4 L 30 S/Z/C	4 L 40 S/Z/C	
1	035 663 00	16	—	
1	036 257 02	—	16	
2	035 664 00	4	—	
2	036 258 02	—	4	
3	036 396 00	1	1	
4	400 025 00	4	4	
5	035 545 00	8	8	
6	034 696 01	1	1	
7	500 137 00	2	2	
8	035 617 02	1	1	
9	500 217 00	1	1	47 x 1,75 DIN 472
10	034 623 00	1	1	
11	501 276 00	1	1	20 x 1,75 DIN 471
12	—	—	—	
13	—	—	—	
14	—	—	—	
15	034 633 00	2	2	
16	035 555 00	5	5	72 mm ϕ
17	035 516 00	5	5	71,5 mm ϕ
18	400 653 00 W4	1	1	
19	502 194 00	1	1	
20	010 909 00	—	1	
20	009 292 01	1	—	
21	500 267 00	2	2	M 8 x 16 DIN 128
22	500 519 00	2	2	M 8 x 20 DIN 912-8.8
23	009 148 02	1	1	
24	501 290 00	2	2	
25	009 308 00	1	1	„D“
26	502 025 01	1	1	
27	—	—	—	
28	501 399 00	1	1	
29	501 289 00	14	14	M 8 x 16 DIN 912-8.8
30	034 692 00	2	3	
31	035 513 00	3	3	
32	032 633 00	1	1	
33	500 028 00	2	2	

Tafel Nr.
Table No.
Tableau No.
Tabla No.

03

Kurbelgehäuse
Crankcase
Carter moteur
Caja cigueñal

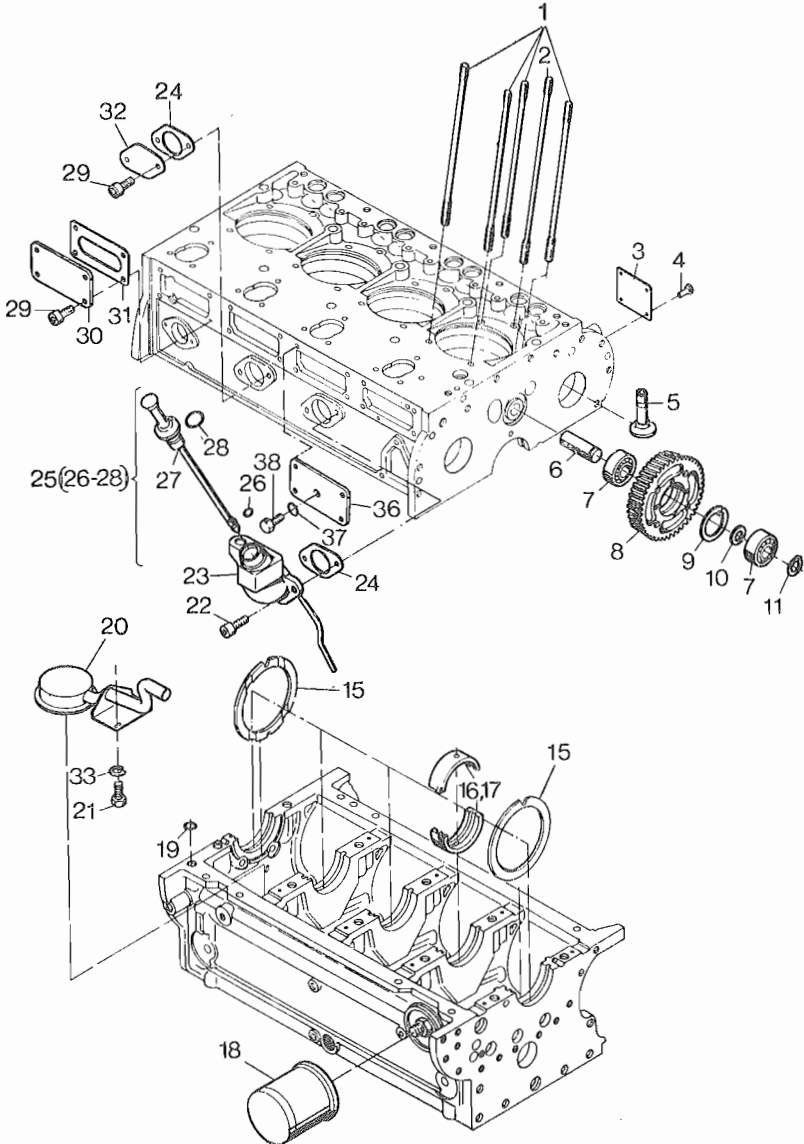

03

	Bestell-Nr. Ordering No. No. référence No. de pedido	Stück Quantity Quantites Cantidades		Hinweis Hints Indications Indicaciones
			4 L.30 S/Z/C	4 M 40 4 L.40 S/Z/C
34	—	—	—	
35	—	—	—	
36	037 620 00	1	—	
37	500 007 00	1	—	A 6 x 12 DIN 7603 Cu
38	500 259 00	1	—	M 6 x 25

Tafel Nr.
Table No.
Tableau No.
Tabla No.

04

Massenausgleich
Compensation of masses
Equilibrage
Compensación de las masas

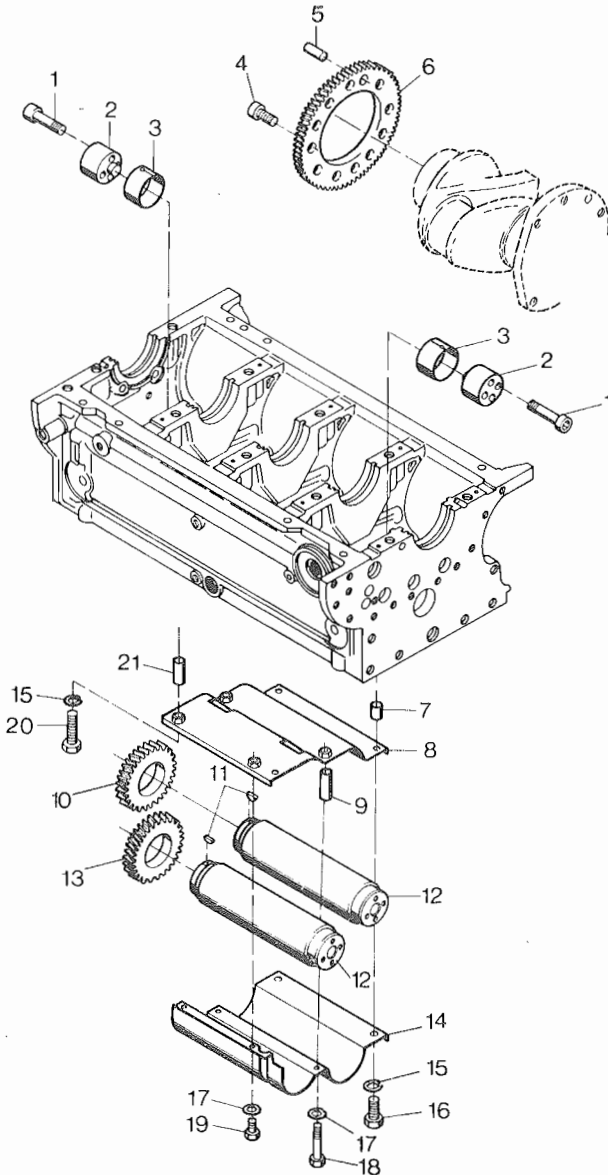

04

	Bestell-Nr. Ordering No. No. référence No. de pedido	Stück Quantity Quantites Cantidades		Hinweis Hints Indications Indicaciones	
		4 L30 Z/C 4 L40 Z/C	4 L30 S/K 4 L40 S/K 4 M 40		
1	501 279 00	16	---	M 8 x 40	DIN 912-10.9
2	036 270 00	4	---		
3	036 272 01	4	---		
4	502 044 00	8	---	M 10 x 20	DIN 6912-12,9
5	502 043 00	1	---	10 m 6 x 20	DIN 7-St50 K
6	035 538 04	1	---		
7	035 996 00	2	---		
8	009 178 00	1	---		
9	035 998 00	2	---		
10	035 534 03	1	---		
11	500 177 00	2	---	4 x 5	DIN 6888
12	---	---	---		
13	035 536 03	1	---		
14	035 992 00	1	---		
15	500 028 00	4	---	8	DIN 128
16	500 519 00	2	---	M 8 x 20	DIN 912-8.8
17	500 812 00	4	---	A 6	DIN 137
18	500 737 00	2	---	M 6 x 45	DIN 931-8.8
19	500 506 00	2	---	M 6 x 12	DIN 931-8.8
20	500 521 00	2	---	M 8 x 25	DIN 912-8.8
21	035 997 00	2	---		

Tafel Nr.
Table No.
Tableau No.
Tabla No.

05

Kurbelwelle
Crankshaft
Vilebrequin
Cigüeñal

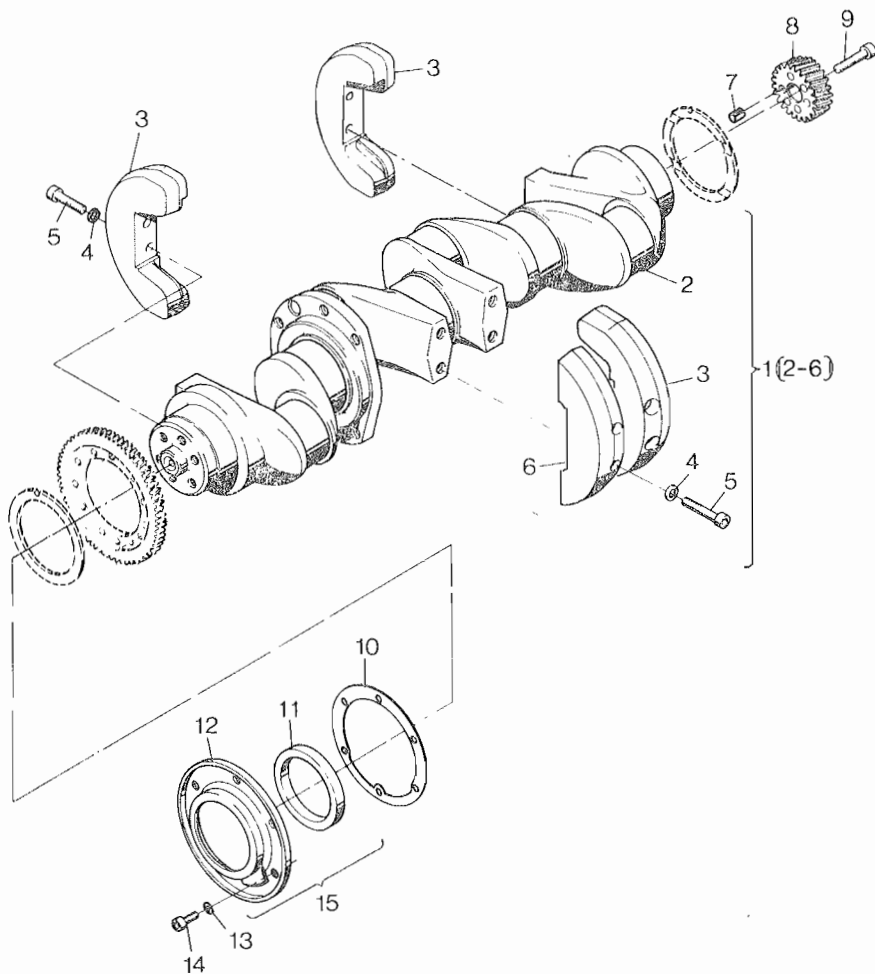

05

	Bestell-Nr. Ordering No. No. référence No. de pedido	Stück Quantity Quantites Cantidades		Hinweis Hints Indications Indicaciones	
		4 L 30	4 L 40 4 M 40		
1	009 022 00	1	—		
1	009 563 00	—	1		
2	—	—	—		
3	—	—	—		
4	500 029 00	8	8	10	DIN 128
5	501 328 00	8	8	M 10 x 40	DIN 912-10.9
6	—	—	—		
7	501 280 00	1	1	11 x 10	DIN 7346 55 Si 7
8	035 616 01	1	1		
9	501 279 00	6	6	M 8 x 40	DIN 912-10.9
10	035 506 01	1	1		
11	501 303 00	1	—		
11	502 246 00	—	1		
12	—	—	—		
13	500 812 00	6	6	A 6	DIN 137
14	502 366 00	6	6	M 6 x 25	DIN 912.8.8
15	009 475 01	1	—		
15	009 575 00	—	1		

Tafel Nr.
Table No.
Tableau No.
Tabla No.

06

Nockenwelle, Regler, Spritzversteller
Camshaft, governor, timer
Arbre à cames, regulateur avance variable du point d'inject.
Arbol de levas, regulador, variador de avance

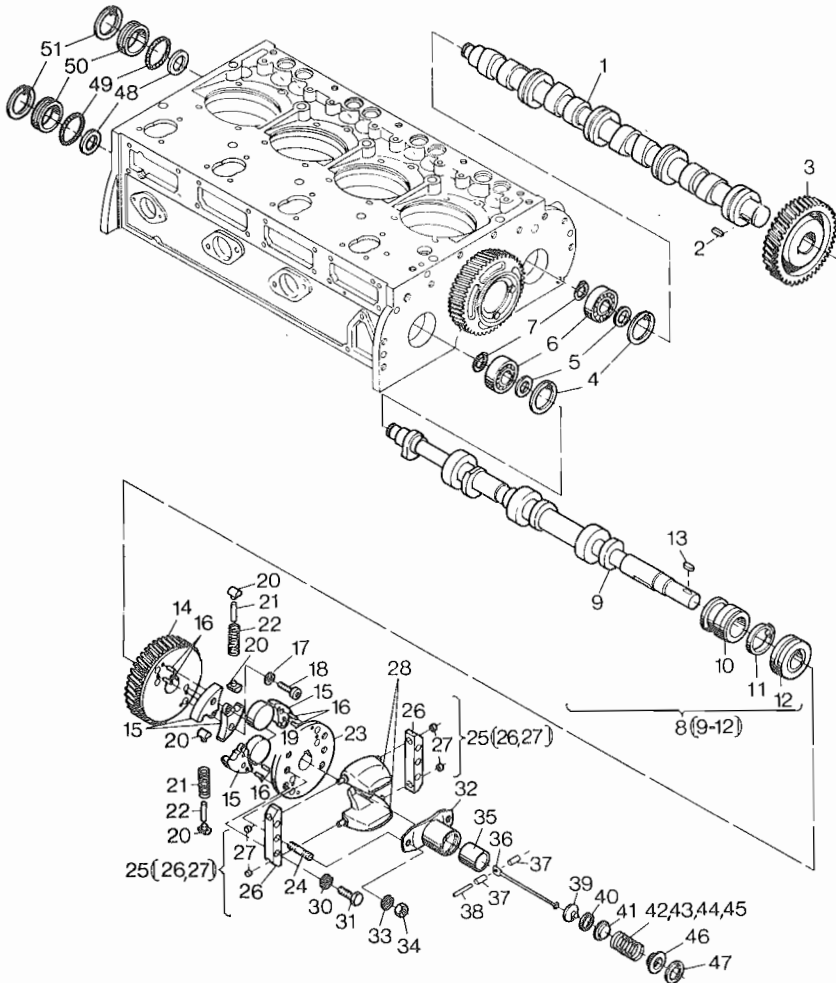

06

	Bestell-Nr. Ordering No. No. référence No. de pedido	Stück Quantity Quantites Cantidades	Hinweis Hints Indications Indicaciones
		4 L 30	
1	035 580 00	1	
2	500 113 00	1	A 8 x 7 x 22 DIN 6885
3	035 618 00	1	
4	500 217 00	2	4 x 1,75 DIN 472
5	501 329 00	0...3	20 x 28 x 0,1 DIN 988
6	500 137 00	2	
7	501 276 00	2	20 x 1,75 DIN 471
8	007 455 01	1	
9	—	—	
10	—	—	
11	037 765 01	1	
12	—	—	
13	501 316 00	1	A 6 x 6 x 20 DIN 6885 St 6
14	035 619 00	1	
15	034 627 01	4	
16	500 579 00	8	
17	501 401 00	8	6 DIN 7980
18	501 432 00	8	
19	034 601 00	2	
20	034 645 00	4	
21	035 613 00	2	
22	035 614 00	2	
23	035 547 00	1	
24	501 315 00	2	M 8 x 30 DIN 938-8.8
25	007 458 00	2	
26	—	—	
27	035 721 00	4	
28	035 729 00	2	
29	—	—	
30	501 282 00	4	8 DIN 127
31	500 270 00	4	M 8 x 25 DIN 938-8.8
32	035 722 00	1	
33	501 282 00	2	8 DIN 127
34	500 229 00	2	M 8 DIN 934-8
35	035 716 00	1	
36	035 717 00	1	

Tafel Nr.
Table No.
Tableau No.
Tabla No.

06

Nockenwelle, Regler, Spritzversteller
Camshaft, governor, timer
Arbre à cames, regulateur avance variable du point d'inject.
Arbol de levas, regulador, variador de avance

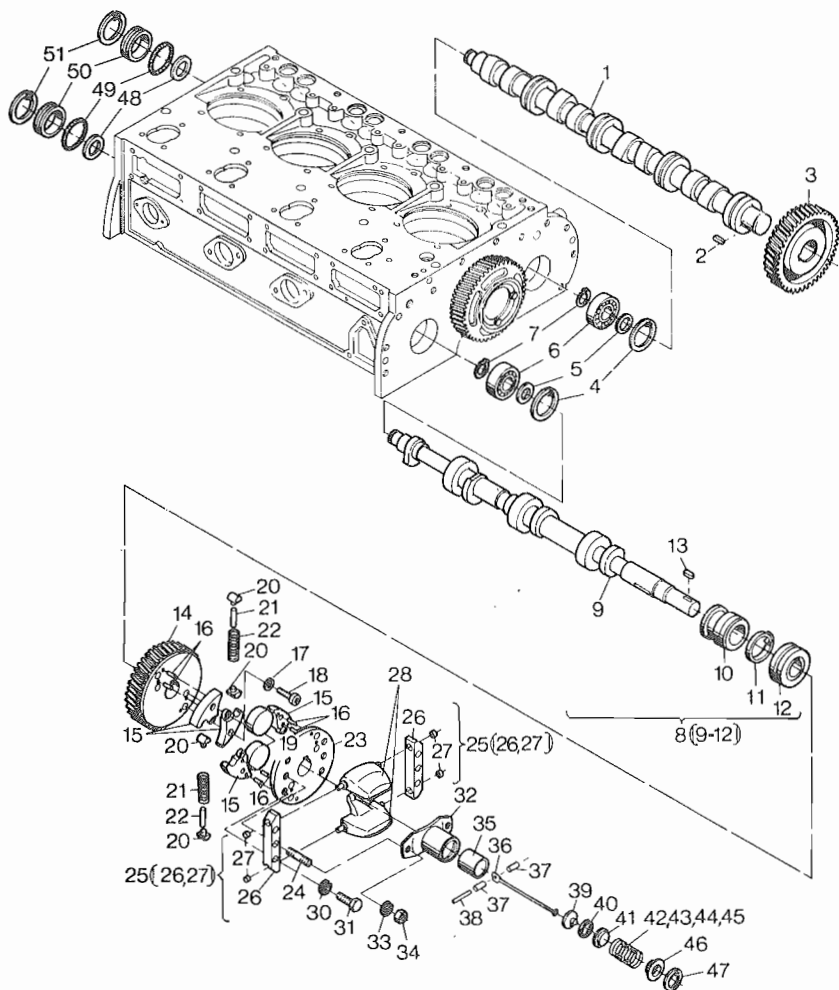

06

	Bestell-Nr. Ordering No. No. référence No. de pedido	Stück Quantity Quantités Cantidades	Hinweis Hints Indications Indicaciones
		4 L 30	
37	035 715 00	2	
38	035 764 00	1	
39	035 720 00	1	
40	501 380 00	1	B 26 DIN 7993
41	035 718 00	1	
42	036 014 01	1	2,5 mm ϕ 1500 min ⁻¹ Gen.
43	036 013 01	1	2,6 mm ϕ 1800 min ⁻¹ Gen.
44	036 012 01	1	3,0 mm ϕ \leq 2300 min ⁻¹
45	035 744 01	1	3,2 mm ϕ $>$ 2300 min ⁻¹
46	035 719 00	1	
47	500 210 00	1	32 x 1,2 DIN 472
48	502 773 00	0...1	37 x 47 x 0,5 DIN 988
48	501 327 00	0...3	37 x 47 x 0,1 DIN 988
49	501 307 00	2	
50	034 697 00	2	
51	500 217 00	2	47 x 1,75 DIN 472

Tafel Nr.
Table No.
Tableau No.
Tabla No.

06

Nockenwelle, Regler, Spritzversteller 4 L 40, 4 M 40
Camshaft, governor, timer
Arbre à cames, regulateur avance variable du point d'injekt.
Arbol de levas, regulador, variador de avance

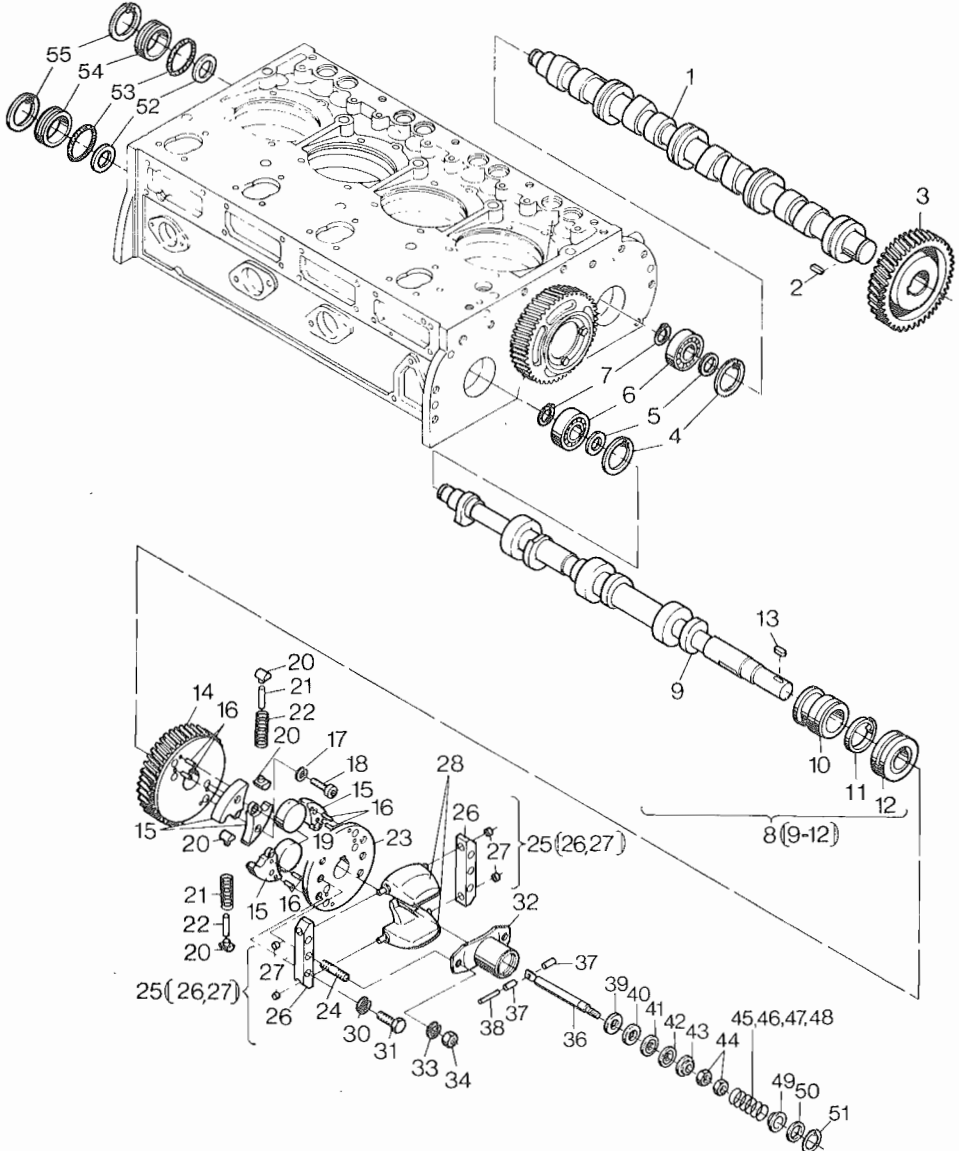

06

Bestell-Nr.
Ordering No.
No. référence
No. de pedido

Stück
Quantity
Quantites
Cantidades

Hinweis
Hints
Indications
Indicaciones

4 L 40, 4 M 40

1	035 580 00	1		
2	500 113 00	1	A 8x7x22	DIN 6885
3	035 618 00	1		
4	500 217 00	2	47 x 1,75	DIN 472
5	501 329 00	3	20 x 28 x 0,1	DIN 988
6	500 137 00	2		
7	501 276 00	2	20 x 1,75	DIN 471
8	012 122 00	1		
9	—	—		
10	—	—		
11	035 765 01	1		
12	—	—		
13	501 316 00	1	A 6 x 6 x 20	DIN 6885 ST6
14	035 619 00	1		
15	034 627 01	4		
16	500 579 00	8	4 m 6 x 8	DIN 7-9S 20K
17	501 401 00	8	6	DIN 7980
18	501 432 00	8	M 6 x 18	DIN 6912-8.8
19	034 601 00	2		
20	034 645 00	4		
21	035 613 00	2		
22	035 614 00	2		
23	035 547 00	1		
24	501 315 00	2	M 8 x 30	DIN 938-8.8
25	007 458 00	2		
26	—	—		
27	035 721 00	4		
28	035 729 00	2		
30	501 282 00	4	8	DIN 127
31	500 270 00	4	M 8 x 25	DIN 933-8.8
32	037 731 00	1		
33	501 282 00	2	8	DIN 127
34	500 229 00	2		
35	—	—		
36	037 726 00	2		
37	037 725 00	2		

Tafel Nr.
 Table No.
 Tableau No.
 Tabla No.

06

Nockenwelle, Regler, Spritzversteller 4 L 40, 4 M 40
 Camshaft, governor, timer
 Arbre à cames, regulateur avance variable du point d'inject.
 Arbol de levas, regulador, variador de avance

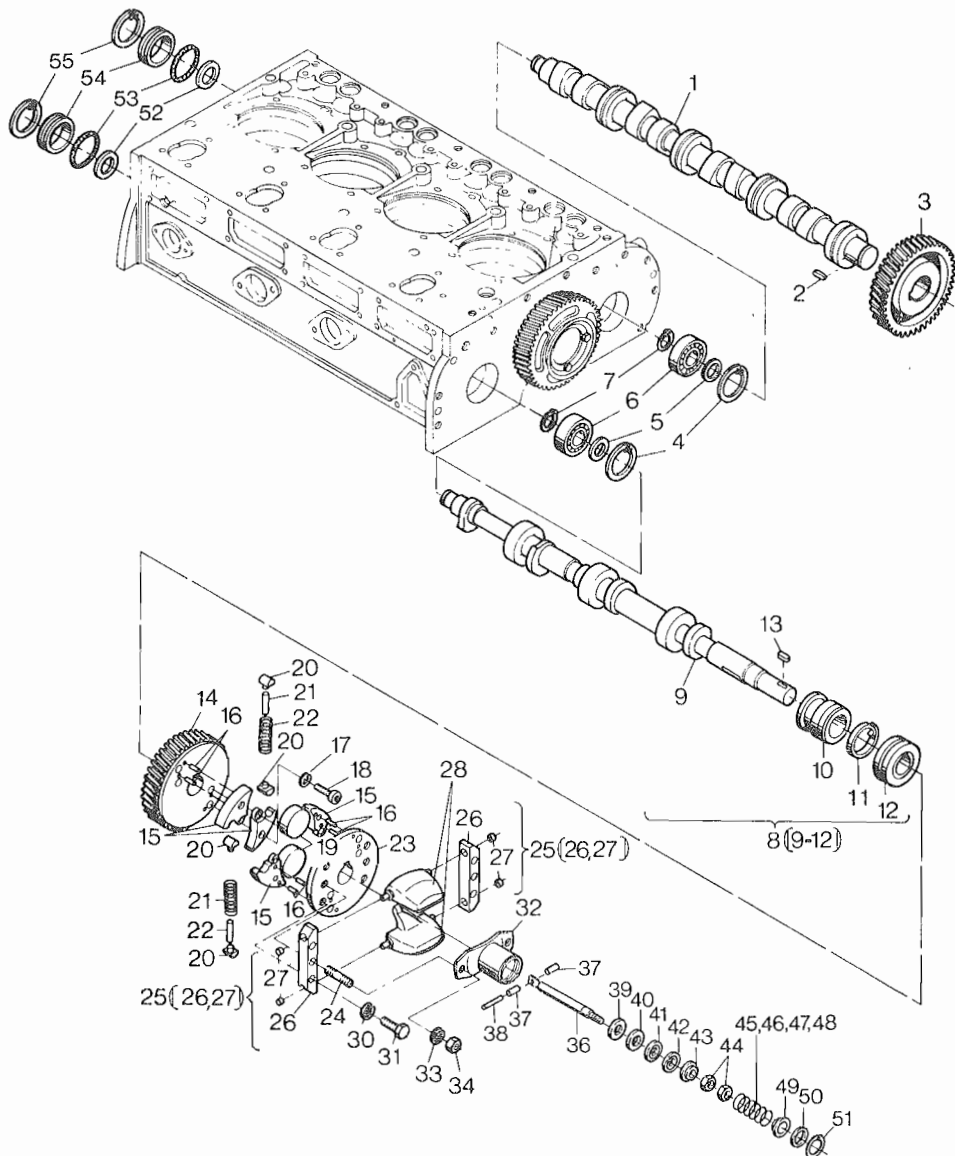

06

Bestell-Nr.
Ordering No.
No. référence
No. de pedido

Stück
Quantity
Quantites
Cantidades

Hinweis
Hints
Indications
Indicaciones

4 L 40, 4 M 40

38	035 764 00	1	
39	037 727 00	1	
40	502 680 00	1	6 x 12 x 0,5 DIN 988
41	502 681 00	1	
42	502 682 00	1	
43	037 728 00	1	
44	500 227 00	2	M 6 DIN 934-8
45	038 670 00	1	2,3 mm ϕ 1500 min ⁻¹ Gen.
46	036 013 00	1	2,6 mm ϕ 1800 min ⁻¹ Gen.
47	036 012 01	1	2,8 mm ϕ \leq 2300
48	035 744 01	1	3,2 mm ϕ $>$ 2300
49	035 719 00	1	
50	037 729 00	1	
51	500 210 00	1	32 x 1,2 DIN 472
52	501 327 00	0...3	37 x 47 x 0,1 DIN 472
52	502 773 00	0...1	37 x 47 x 0,5 DIN 988
53	501 307 00	2	
54	034 697 00	2	
55	500 217 00	2	47 x 1,75 DIN 988

Tafel Nr.
Table No.
Tableau No.
Tabla No.

07

Drehzahlverstellung
Speed control
Reglage regime
Ajuste de revoluciones

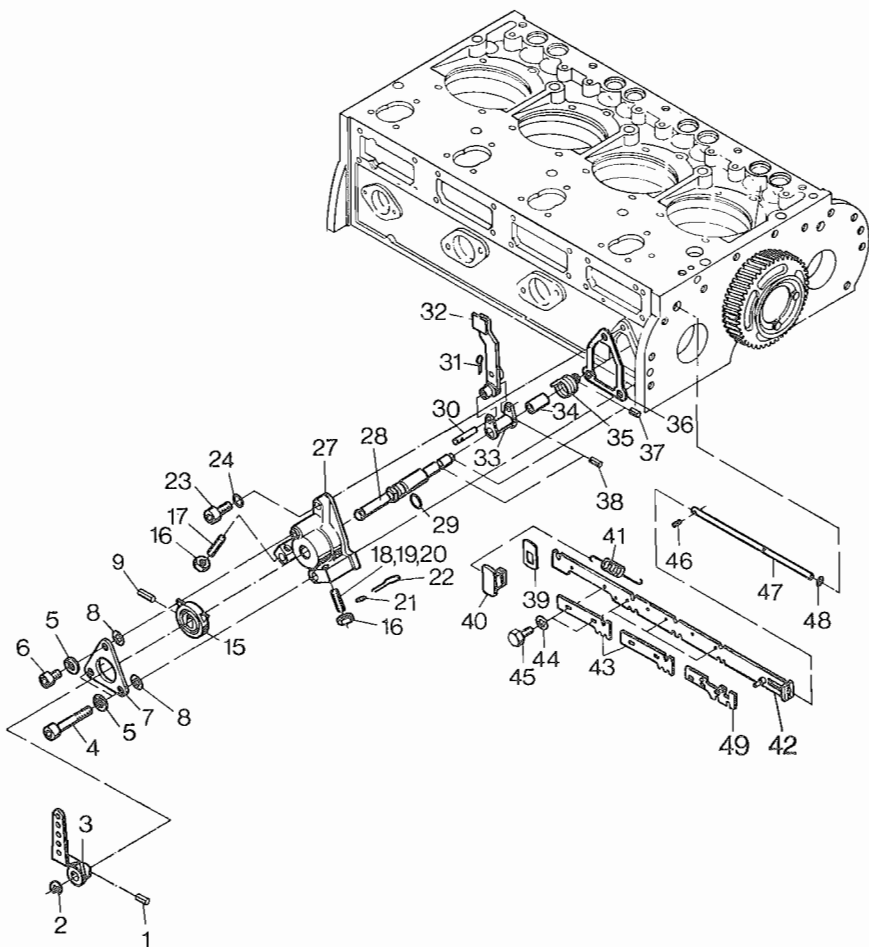

07

	Bestell-Nr. Ordering No. No. référence No. de pedido	Stück Quantity Quantites Cantidades	Hinweis Hints Indications Indicaciones
4 L 30			
1	501 320 00	1	4 x 16 DIN 1481
2	501 529 00	1	
3	007 920 01	1	
4	500 530 00	2	M 8 x 70 DIN 912-8.8
5	501 282 00	3	8 DIN 127
6	500 516 00	1	M 8 x 16 DIN 912-8.8
7	034 658 00	1	
8	032 130 00	0...3	0,3 mm
8	032 131 00	0...3	0,5 mm
9	500 350 00	1	5 x 40 DIN 1481
10	—	—	
11	—	—	
12	—	—	
13	—	—	
14	—	—	
15	034 688 10	1	
16	500 229 00	2	M 8 DIN 934-8
17	032 459 00	1	AM 8 x 35
18	032 459 00	1	35 mm $n > 2600 \text{ min}^{-1}$
19	037 740 00	1	40 mm $n = 2200 \dots 2600 \text{ min}^{-1}$
19	036 429 00	1	45 mm $n = 2200 \dots 2600 \text{ min}^{-1}$
20	031 695 01	1	50 mm $n < 2200 \text{ min}^{-1}$
21	400 214 00	1	
22	400 215 00	1	
23	500 519 00	1	M 8 x 20 DIN 912-8.8
24	501 629 00	1	A 8 x 14 DIN 7603-Cu
25	—	—	
26	—	—	
27	035 542 10	1	
28	034 689 20	1	
29	400 817 00	1	
30	034 690 00	1	
31	500 361 00	1	2 x 22 DIN 94
32	007 399 10	1	
33	034 691 00	1	
34	034 678 00	1	

Tafel Nr.
Table No.
Tableau No.
Tabla No.

07

Drehzahlverstellung
Speed control
Reglage regime
Ajuste de revoluciones

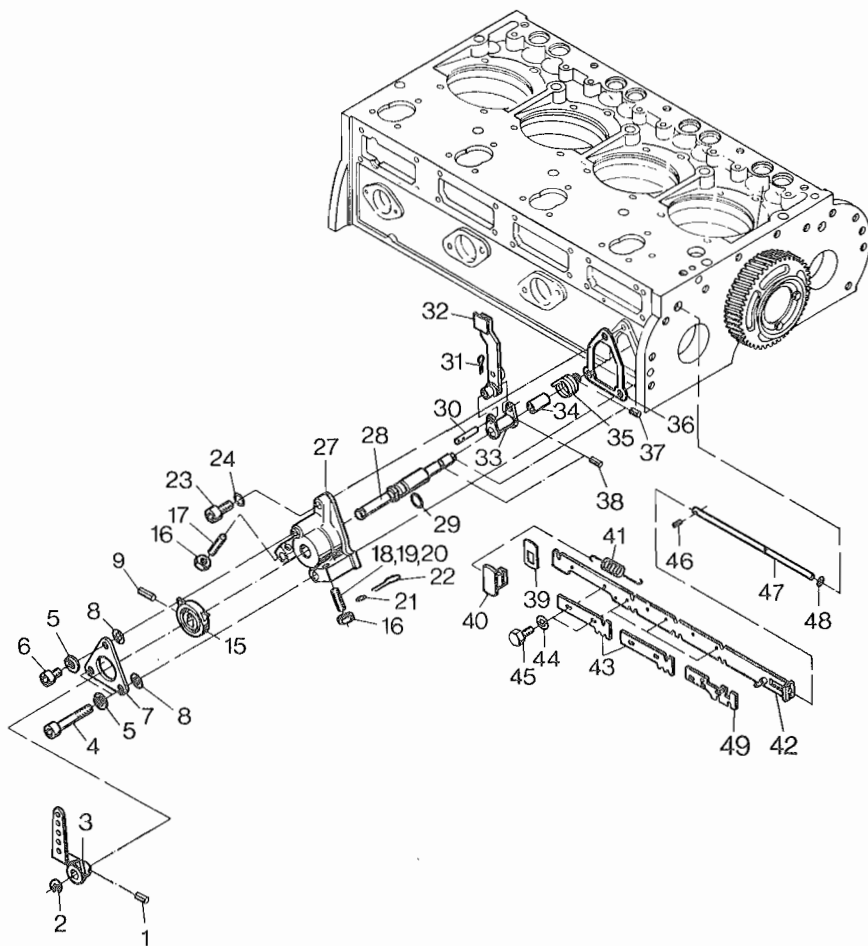

07

Bestell-Nr. Ordering No. No. référence No. de pedido	Stück Quantity Quantites Cantidades	Hinweis Hints Indications Indicaciones
---	--	---

4 L 30

35	034 679 00	1		
36	034 659 00	1		
37	501 320 00	1	4 x 16	DIN 1481
38	501 319 00	1	4 x 12	DIN 1481
39	036 432 00	0...3		
40	035 626 00	1		
41	034 681 00	1		
42	007 407 12	1		
43	034 685 01	2		
44	500 034 00	6	A 4	DIN 137
45	502 504 00	6	M 4 x 7	DIN 933-8.8
46	501 318 00	1	2,5 x 10	DIN 1481
47	034 606 00	1		
48	400 223 00	1		
49	010 654 00	1		

Tafel Nr.
Table No.
Tableau No.
Tabla No.

07

Drehzahlverstellung — 4 L 40, 4 M 40
Speed control — 4 L 40, 4 M 40
Reglage regime — 4 L 40, 4 M 40
Ajuste de revoluciones — 4 L 40, 4 M 40

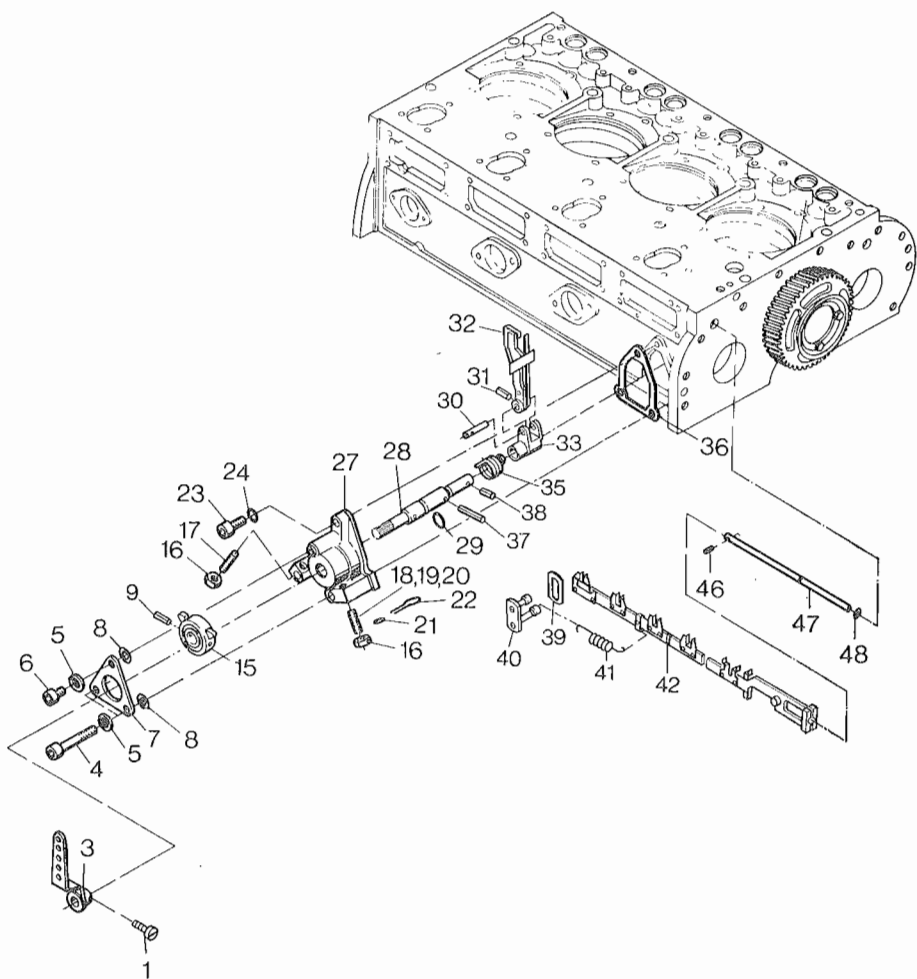

07

Bestell-Nr. Ordering No. No. référence No. de pedido	Stück Quantity Quantites Cantidades	Hinweis Hints Indications Indicaciones
---	--	---

4 L 40, 4 M 40

1	500 494 00	1	M 5 x 20	DIN 84-4.8
2	—	—		
3	007 920 10	1		
4	500 530 00	2	M 8 x 70	DIN 912-8.8
5	501 282 00	3	8	DIN 127
6	500 516 00	1	M 8 x 16	DIN 912-8.8
7	034 658 00	1		
8	032 130 00	0...3	0,3 mm	
8	032 131 00	0...3	0,5 mm	
9	500 350 00	1	5 x 40	DIN 1481
10	—	—		
11	—	—		
12	—	—		
13	—	—		
14	—	—		
15	034 688 10	1		
16	500 229 00	1	M 8	DIN 934-8
17	032 459 00	1	AM 8 x 35	
18	032 459 00	1	35 mm	n > 2600 min ⁻¹
19	036 429 00	1	45 mm	n = 2200...2600 min ⁻¹
19	037 740 00	1	40 mm	n = 2200...2600 min ⁻¹
20	031 695 01	1	50 mm	n < 2200 min ⁻¹
21	400 214 00	1		
22	400 215 00	1		
23	500 519 00	1	M 8 x 20	DIN 912-8.8
24	501 629 00	1	A 8 x 14	DIN 7603-Cu
25	—	—		
26	—	—		
27	035 542 11	1		
28	034 689 30	1		
29	400 817 00	1		
30	034 690 10	1		
31	501 275 00	1	3 x 14	DIN 1481
32	010 862 00	1		
33	034 691 10	1		
34	—	—		

Tafel Nr.
Table No.
Tableau No.
Tabla No.

07

Drehzahlverstellung — 4 L 40, 4 M 40
Speed control — 4 L 40, 4 M 40
Reglage regime — 4 L 40, 4 M 40
Ajuste de revoluciones — 4 L 40, 4 M 40

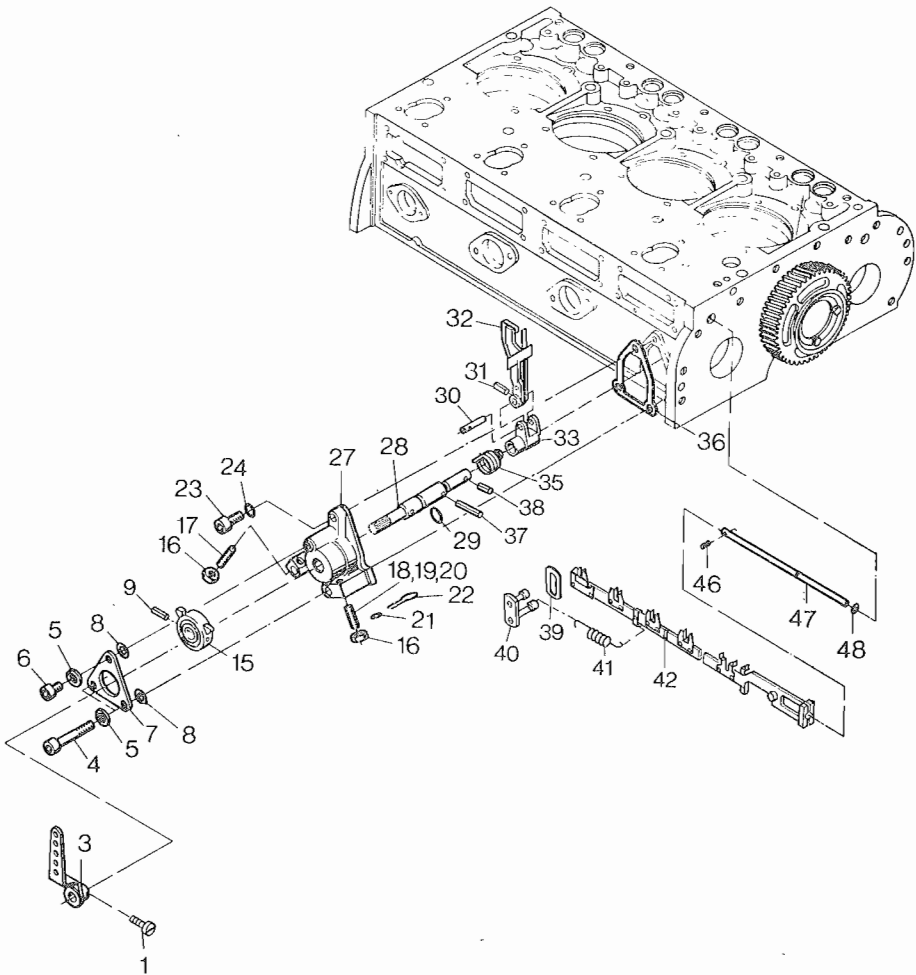

07Bestell-Nr.
Ordering No.
No. référence
No. de pedidoStück
Quantity
Quantites
CantidadesHinweis
Hints
Indications
Indicaciones

4 L 40, 4 M 40

35	038 614 00	1		
36	034 659 00	1		
37	502 690 00	1	4 x 26	DIN 1481
38	501 319 00	1	4 x 12	DIN 1481
39	038 650 00	0...3		
40	010 667 00	1		
41	034 681 00	1		
42	010 670 01	1		
46	501 318 00	1	2,5 x 10	DIN 1481
47	034 606 00	1		
48	400 223 00	1		

Tafel Nr.
Table No.
Tableau No.
Tabla No.

08

Pleuelstange, Kolben, Zylinder
Conrod, piston, cylinder
Bielle, piston, cylindre
Biela, émbolo, cilindro

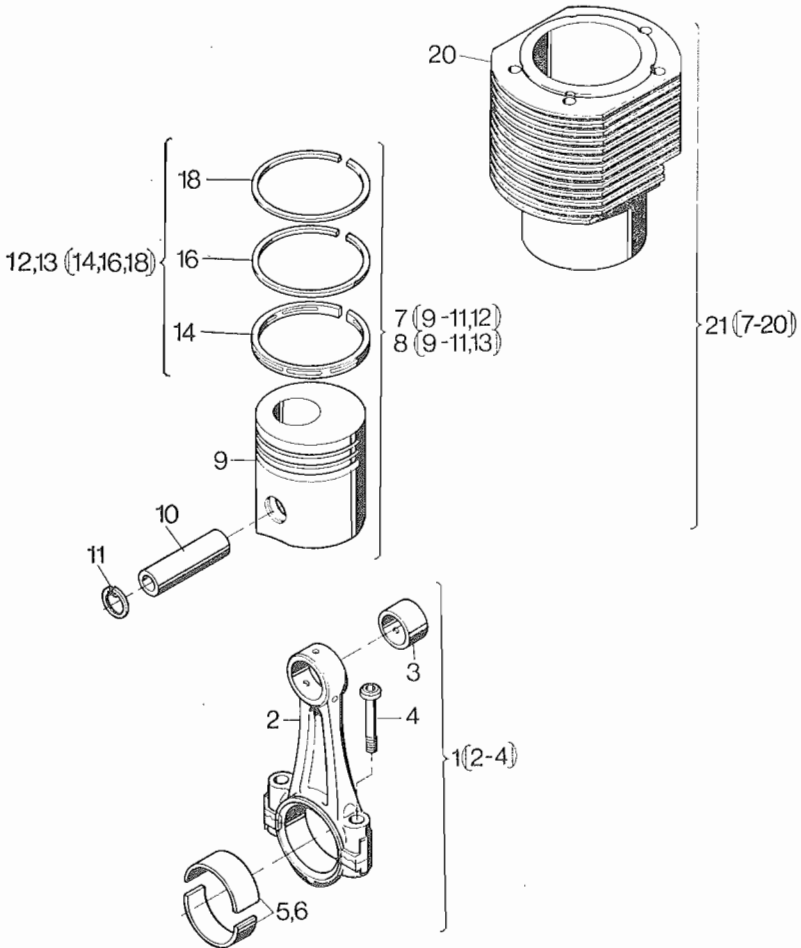

08

	Bestell-Nr. Ordering No. No. référence No. de pedido	Stück Quantity Quantites Cantidades		Hinweis Hints Indications Indicaciones
		4 L 30	4 L 40, 4 M 40	
1	007 410 03	4	—	
1	009 297 01	—	4	
2	—	—	—	
3	036 212 00	4	—	
3	037 530 00	—	4	
4	034 695 00	8	8	
5	035 546 00	4	—	60 mm ϕ
5	036 184 01	—	4	64 mm ϕ
6	035 514 00	4	—	59,5 mm ϕ
6	037 531 00	—	4	63,5 mm ϕ
7	007 478 02	4	—	95 mm ϕ
7	009 541 01	—	4	102 mm ϕ
8	009 205 01	4	—	96 mm ϕ
8	009 722 00	—	4	103 mm ϕ
9	—	—	—	
10	502 035 00	4	—	
10	502 361 00	—	4	
11	500 210 00	8	—	32 x 1,2 DIN 472
11	502 360 00	—	8	36 x 1,5 DIN 472
12	009 196 01	4	—	95 mm
12	009 558 00	—	4	102 mm ϕ
13	009 197 01	4	—	96 mm ϕ
13	009 723 00	—	4	103 mm ϕ
14	—	—	—	
15	—	—	—	
16	—	—	—	
17	—	—	—	
18	—	—	—	
19	—	—	—	
20	035 587 00	4	—	95 mm ϕ
20	036 185 02	—	4	102 mm
21	009 265 00	4	—	95 mm
21	009 734 01	—	4	102 mm

Tafel Nr.
Table No.
Tableau No.
Tabla No.

09

Zylinderkopf
Cylinder head
Culasse
Culata

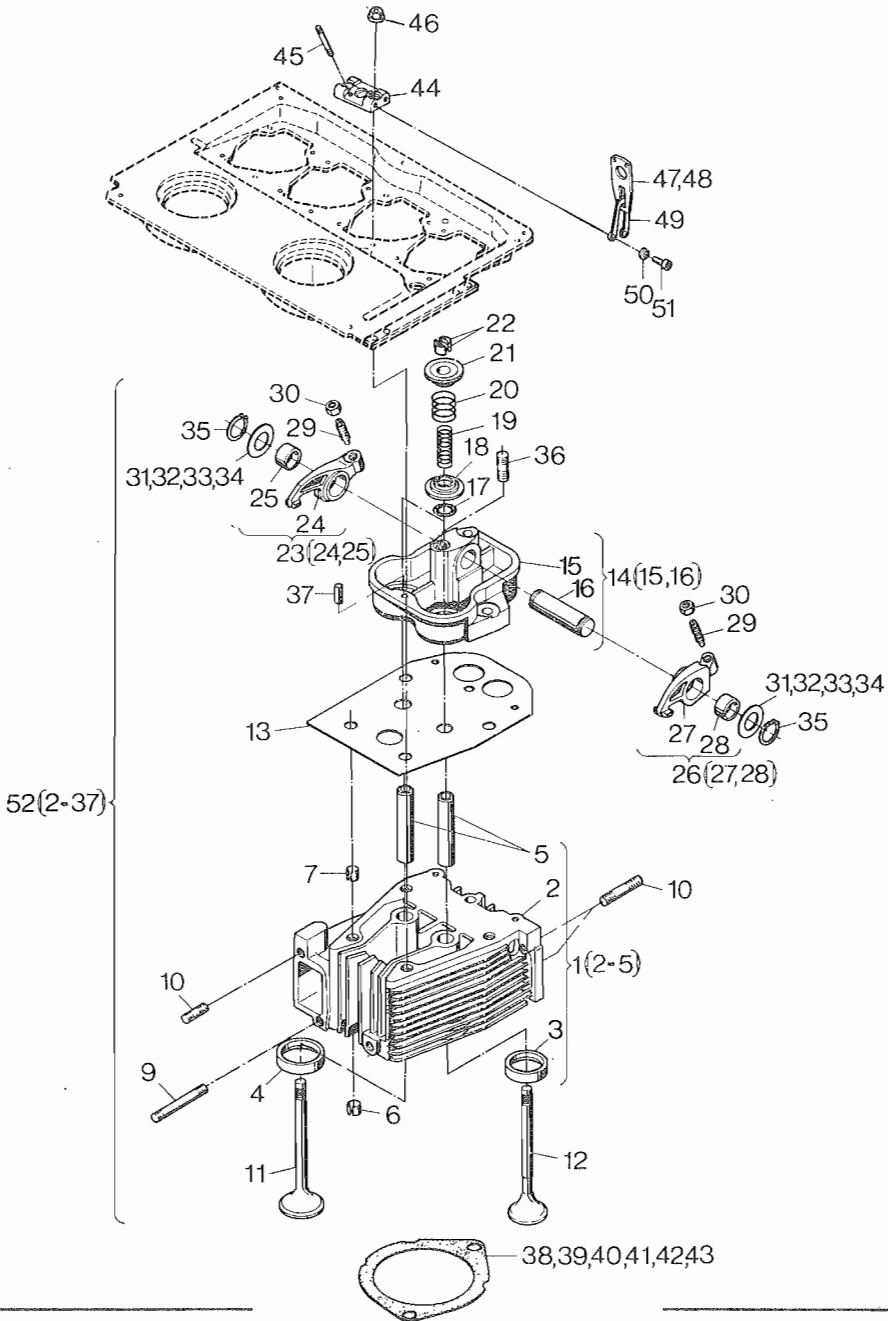

09

	Bestell-Nr. Ordering No. No. référence No. de pedido	Stück Quantity Quantites Cantidades				Hinweis Hints Indications Indicaciones	
		4 L30 S/Z	4 L30 C/K	4 M 40 4 L40 S/Z	4 L40 C/K		
1	007 390 01	4	4	—	—		
1	009 330 01	—	—	4	4	4 M 40 L	
1	009 936 00	—	—	4	—	4 M 40 H	
2	—	—	—	—	—		
3	—	—	—	—	—		
4	—	—	—	—	—		
5	034 487 01	8	8	8	8		
6	501 336 00	8	8	—	—	13 x 18	DIN 7346
7	501 277 00	16	16	—	—	12 x 14	DIN 7346
7	502 248 00	—	—	16	16	13 x 14	DIN 7346
8	—	—	—	—	—		
9	501 325 00	4	4	4	4	M 8 x 65	DIN 835-8.8
10	501 281 00	12	12	12	12	M 8 x 30	DIN 935-10.9
11	036 145 00	4	4	—	—		
11	036 255 00	—	—	4	4		
12	036 146 00	4	4	—	—		
12	036 256 00	—	—	4	4		
13	035 665 00	4	4	—	—		
13	036 248 00	—	—	4	4		
14	009 424 01	4	4	—	—		
14	009 562 00	—	—	4	4		
15	—	—	—	—	—		
16	034 698 00	4	4	4	4		
17	502 255 00	8	8	8	8		
18	033 930 10	8	8	8	8		
19	031 835 00	8	8	8	8		
20	033 256 00	8	8	8	8		
21	030 434 02	8	8	8	8		
22	036 209 00	8	8	8	8		
23	005 325 00	4	4	4	4		
24	—	—	—	—	—		
25	031 841 00	4	4	4	4		
26	009 328 00	4	4	4	4		
27	—	—	—	—	—		
28	031 841 00	4	4	4	4		
29	030 431 00	8	8	8	8	n > 1800 min ⁻¹	

Tafel Nr.
Table No.
Tableau No.
Tabla No.

09

Zylinderkopf
Cylinder head
Culasse
Culata

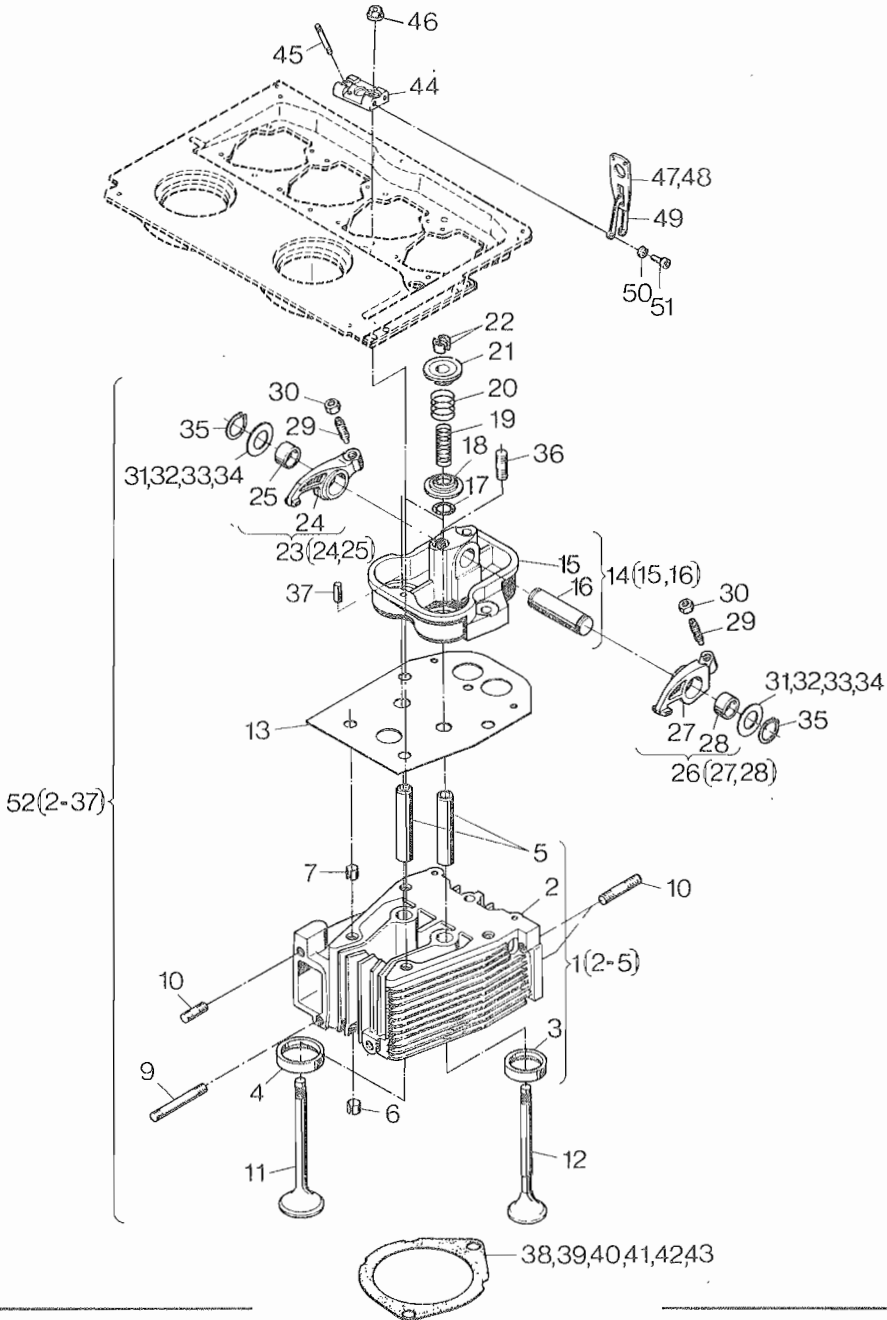

09

	Bestell-Nr. Ordering No. No. référence No. de pedido	Stück Quantity Quantities Cantidades				Hinweis Hints Indications Indicaciones	
		4 L 30 S/Z	4 L 30 C/K	4 M 40 4 L 40 S/Z	4 L 40 C/K		
29	037 720 00	8	8	8	8	n < 1800 min ⁻¹	
30	031 490 00	8	8	8	8		
31	035 806 00	0...8	0...8	0...8	0...8	0,15 mm	
32	032 332 00	0...8	0...8	0...8	0...8	0,20 mm	
33	032 333 00	0...8	0...8	0...8	0...8	0,30 mm	
34	034 560 00	0...8	0...8	0...8	0...8	0,40 mm	
35	500 202 00	8	8	8	8	19 x 1,2	DIN 471
36	500 405 00	4	4	4	4	M 10 x 25	DIN 939-5.6
37	500 352 00	4	4	4	4	6 x 12	DIN 1481
38	035 588 00	4	4	—	—	0,7 mm	
38	036 259 01	—	—	4	4	0,7 mm	
39	035 589 00	4	4	—	—	0,8 mm	
39	036 260 01	—	—	4	4	0,8 mm	
40	035 590 00	4	4	—	—	0,9 mm	
40	036 261 01	—	—	4	4	0,9 mm	
41	035 591 00	4	4	—	—	1,0 mm	
41	036 262 01	—	—	4	4	1,0 mm	
42	035 292 00	4	4	—	—	1,1 mm	
42	036 263 01	—	—	4	4	1,1 mm	
43	035 593 00	4	4	—	—	1,2 mm	
43	036 264 01	—	—	4	4	1,2 mm	
44	034 661 00	4	4	—	—		
44	036 249 00	—	—	4	4		
45	501 287 00	8	8	—	—	M 8 x 50	DIN 939.8.8
45	502 390 00	—	—	8	8		
46	032 150 00	20	20	—	—		
46	036 481 00	—	—	20	20		
47	035 691 00	1	—	1	—		
48	035 920 00	—	1	—	1		
49	035 692 00	1	1	—	—		
49	036 250 00	—	—	1	1		
50	501 282 00	2	2	2	2	8	DIN 127
51	501 297 00	2	2	2	2	M 8 x 18	DIN 912-10.9
52	009 195 01	4	4	—	—	n > 1800 min ⁻¹	
52	012 108 00	4	4	—	—	n ≤ 1800 min ⁻¹	

Tafel Nr.
Table No.
Tableau No.
Tabla No.

10

Stoßstange, Ölpumpe
Pushrod, oil pump
Tige de culbuteur, pompe a huile
Varilla de balancín, bomba de aceite

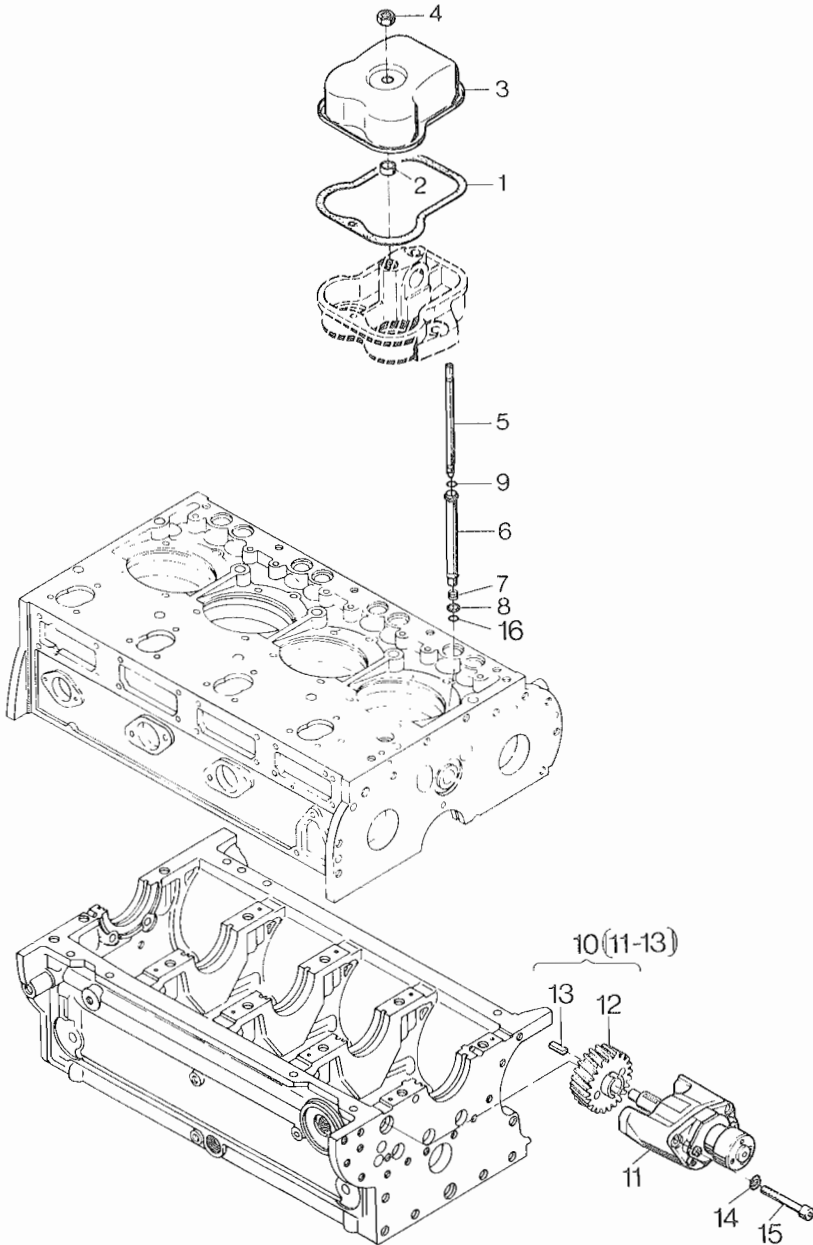

10

	Bestell-Nr. Ordering No. No. référence No. de pedido	Stück Quantity Quantités Cantidades		Hinweis Hints Indications Indicaciones	
		4 L 30	4 M 40, 4 L 40		
1	034 699 00 W8	4	—		
1	502 249 00 W8	—	4		
2	036 083 00	4	—		
3	009 126 00	4	—		
3	036 426 01	4	4		
4	501 323 00 W8	4	4		
5	007 436 00	8	8		
6	035 667 01	8	8		
7	031 851 00	8	8		
8	031 852 00	8	8		
9	502 580 00	8	8		
10	009 239 02	1	1		
11	—	—	—		
12	035 620 10	1	1		
13	500 108 00	1	1	4 x 4 x 25	DIN 6885
14	500 028 00	3	3	8	DIN 128
15	502 068 00	3	3	8 x 105	DIN 912-8.8
16	400 228 00	8	8		

Tafel Nr.
Table No.
Tableau No.
Tabla No.

11

Steuerdeckel, Startfüllung
Timing cover, extra fuel device
Couvercle distribut, surcharge
Tapa de mando, sobre alimentación-arranque

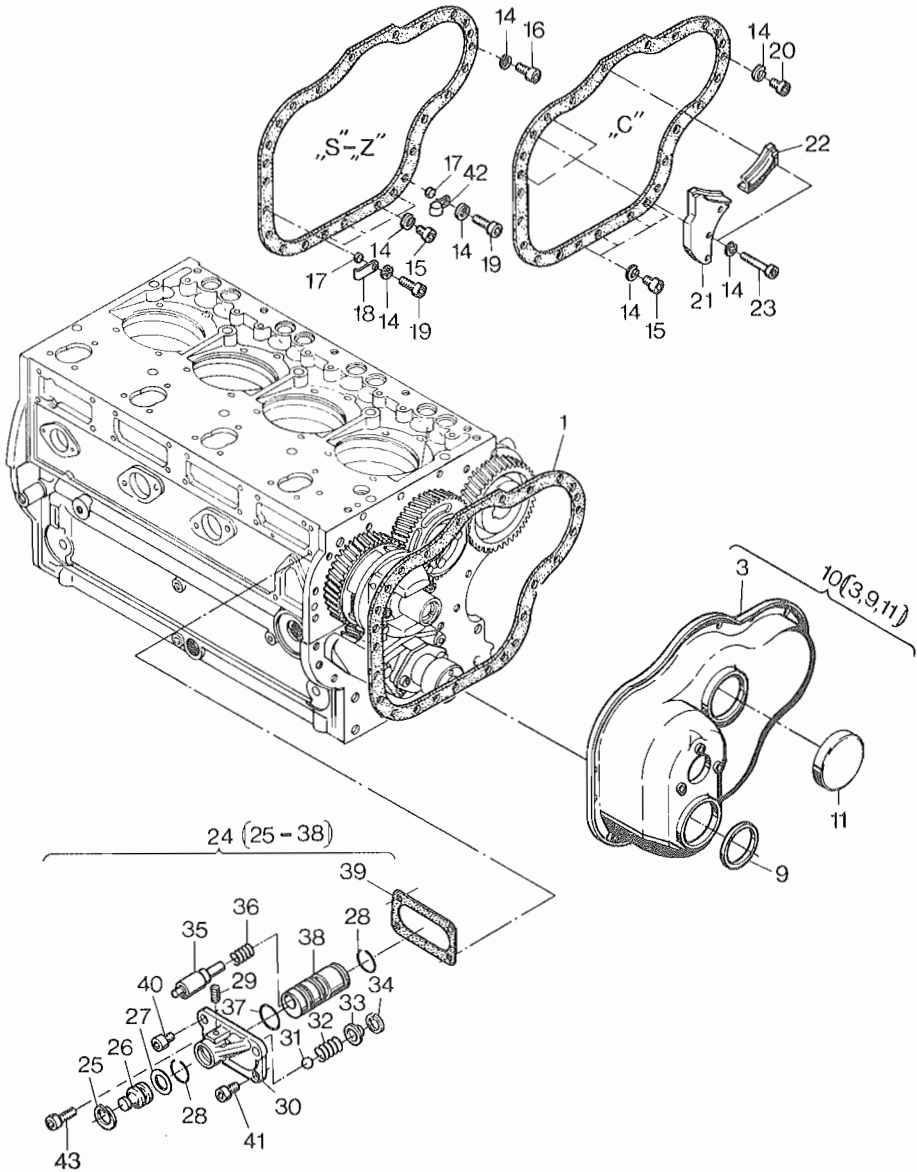

	Bestell-Nr. Ordering No. No. référence No. de pedido	Stück Quantity Quantites Cantidades		Hinweis Hints Indications Indicaciones	
		4 L 30 S/Z	4 L 30 C/K		
1	035 569 01	1	1		
2	—	—	—		
3	—	—	—		
4	—	—	—		
5	—	—	—		
6	—	—	—		
7	—	—	—		
8	—	—	—		
9	501 291 00	1	1		
10	009 932 00	1	1		
11	501 265 00	1	1		
12	—	—	—		
13	—	—	—		
14	500 028 00	22	22	8	DIN 128
15	502 058 00	4	4	M 8 x 12	DIN 912-8.8
16	500 516 00	17	—	M 8 x 16	DIN 912-8.8
17	031 182 00	2	—		
18	531 592 00	1	—		
19	500 521 00	2	—	M 8 x 25	DIN 912-8.8
20	500 516 00	—	14	M 8 x 16	DIN 912-8.8
21	009 028 00	—	1		
22	—	—	—		
23	500 528 00	—	4	M 8 x 55	DIN 912-8.8
24	007 400 01	1	1		
25	502 039 00	1	1	18 x 1	DIN 472
26	036 151 00	1	1		
27	502 245 00	1	1		
28	501 423 00	2	2	28	DIN 9045
29	501 424 00	1	1	M 6 x 10	DIN 914-45H
30	—	—	—		
31	500 099 00	1	1	8 mm	DIN 5401
32	—	—	—		
33	—	—	—		
34	501 425 00	1	1	11 x 1	DIN 472
35	—	—	—		
36	—	—	—		

Tafel Nr.
Table No.
Tableau No.
Tabla No.

11

Steuerdeckel, Startfüllung
Timing cover, extra fuel device
Couvercle distribut, surcharge
Tapa de mando, sobre alimentación-arranque

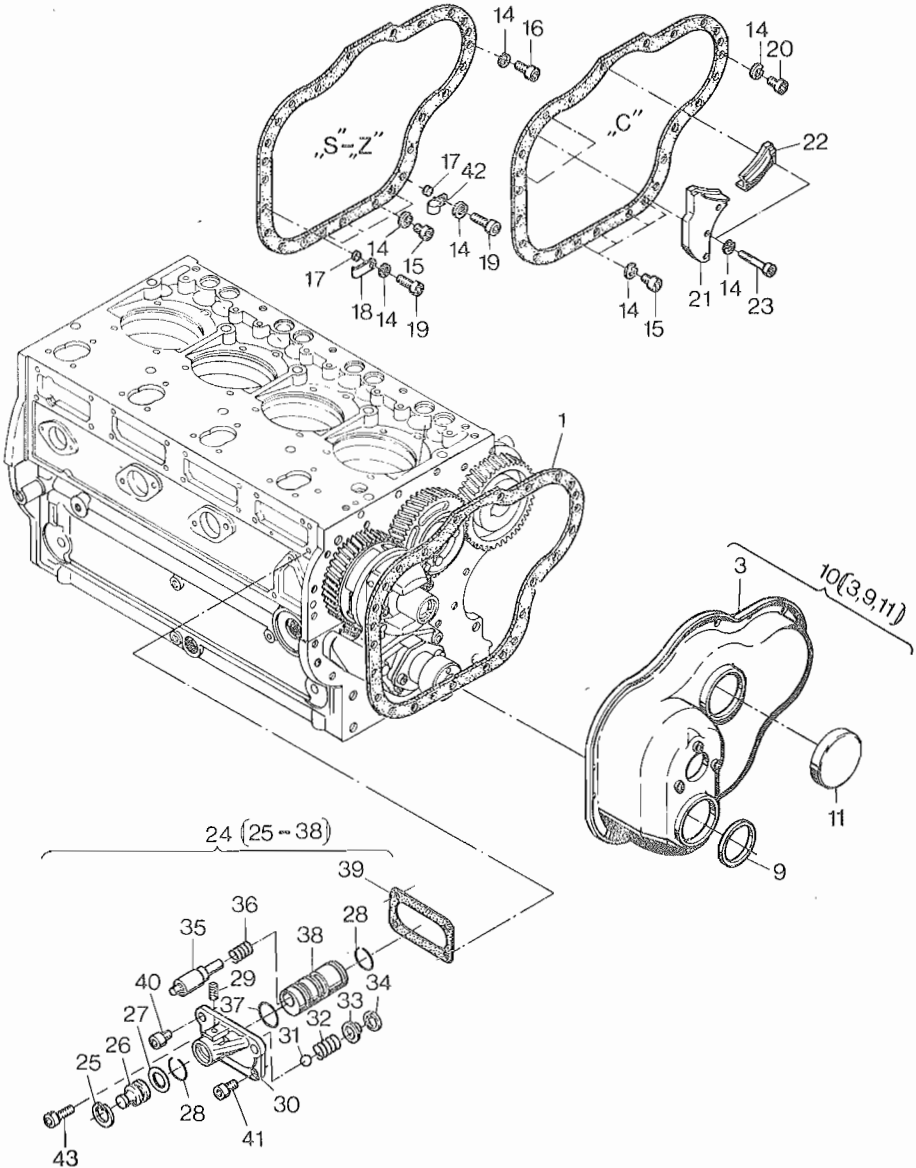

11

	Bestell-Nr. Ordering No. No. référence No. de pedido	Stück Quantity Quantites Cantidades		Hinweis Hints Indications Indicaciones	
		4 L 30 S/Z	4 L 30 C/K		
37	501 422 00	2	2		
38	—	—	—		
39	036 140 00	1	1		
40	400 808 00	2	2	M 8 x 20	DIN 912-8.8
41	501 289 00	1	1	M 8 x 16	DIN 912-8.8
42	031 655 00	1	—		
43	502 579 00	1	1	M 8 x 12	DIN 6912-8.8

Tafel Nr.
Table No.
Tableau No.
Tabla No.

11

Steuerdeckel, Startfüllung - 4 L 40, 4 M 40
Timing cover, extra fuel device - 4 L 40, 4 M 40
Couvercle distribut, surcharge - 4 L 40, 4 M 40
Tapa de mando, sobre alimentación - arranque - 4 L 40, 4 M 40

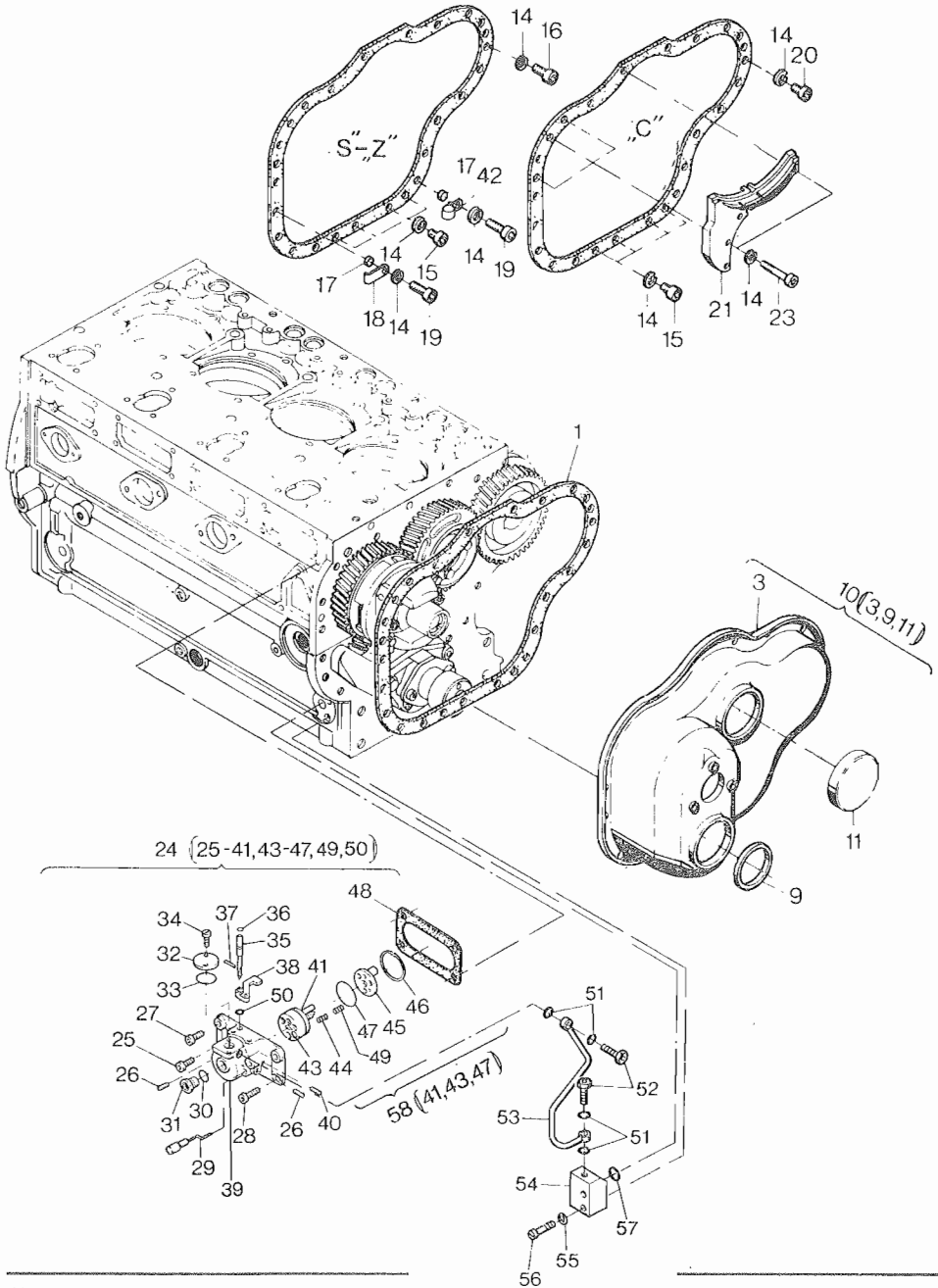

	Bestell-Nr. Ordering No. No. référence No. de pedido	Stück Quantity Quantites Cantidades		Hinweis Hints Indications Indicaciones	
		4 L 40 S/Z 4 M 40		4 L 40 C/K	
1	035 569 01	1		1	
2	--	--		--	
3	--	--		--	
4	--	--		--	
5	--	--		--	
6	--	--		--	
7	--	--		--	
8	--	--		--	
9	501 291 00	1		1	
10	009 932 00	1		1	
11	501 265 00	1		1	
12	--	--		--	
13	--	--		--	
14	500 028 00	22		22	8 DIN 128
15	502 058 00	4		4	8 x 12 DIN 912-8.8
16	500 516 00	16		--	M 8 x 16 DIN 912-8.8
17	031 182 00	2		--	
18	031 592 00	1		--	
19	500 521 00	2		--	M 8 x 25 DIN 912-8.8
20	500 516 00	--		13	M 8 x 16 DIN 912-8.8
21	009 028 00	--		1	
22	--	--		--	
23	500 528 00	--		5	M 8 x 55 DIN 912-8.8
24	012 019 01	1		1	
25	501 349 00	1		1	M 8 x 16 DIN 6912-8.8
26	502 624 00	2		2	M 10 x 6 DIN 916
27	501 289 00	1		1	M 8 x 16 DIN 912
28	400 808 00	2		2	M 8 x 20 DIN 912
29	010 762 00	1		1	
30	500 012 00	1		1	14 x 18 DIN 7603-Cu
31	501 435 00	1		1	M 14 x 1,5 DIN 908
32	038 591 00	1		1	
33	501 304 00	1		1	16,3 x 2,4 x 21,1
34	500 492 00	2		2	M 4 x 10 DIN 84-4.8 A3C
35	038 288 00	1		1	
36	400 217 00	1		1	4,47 x 8,03 x 1,78

Tafel Nr.
Table No.
Tableau No.
Tabla No.

11

Steuerdeckel, Startfüllung - 4 L 40, 4 M 40
Timing cover, extra fuel device - 4 L 40, 4 M 40
Couvercle distribut, surcharge - 4 L 40, 4 M 40
Tapa de mando, sobre alimentación - arranque - 4 L 40, 4 M 40

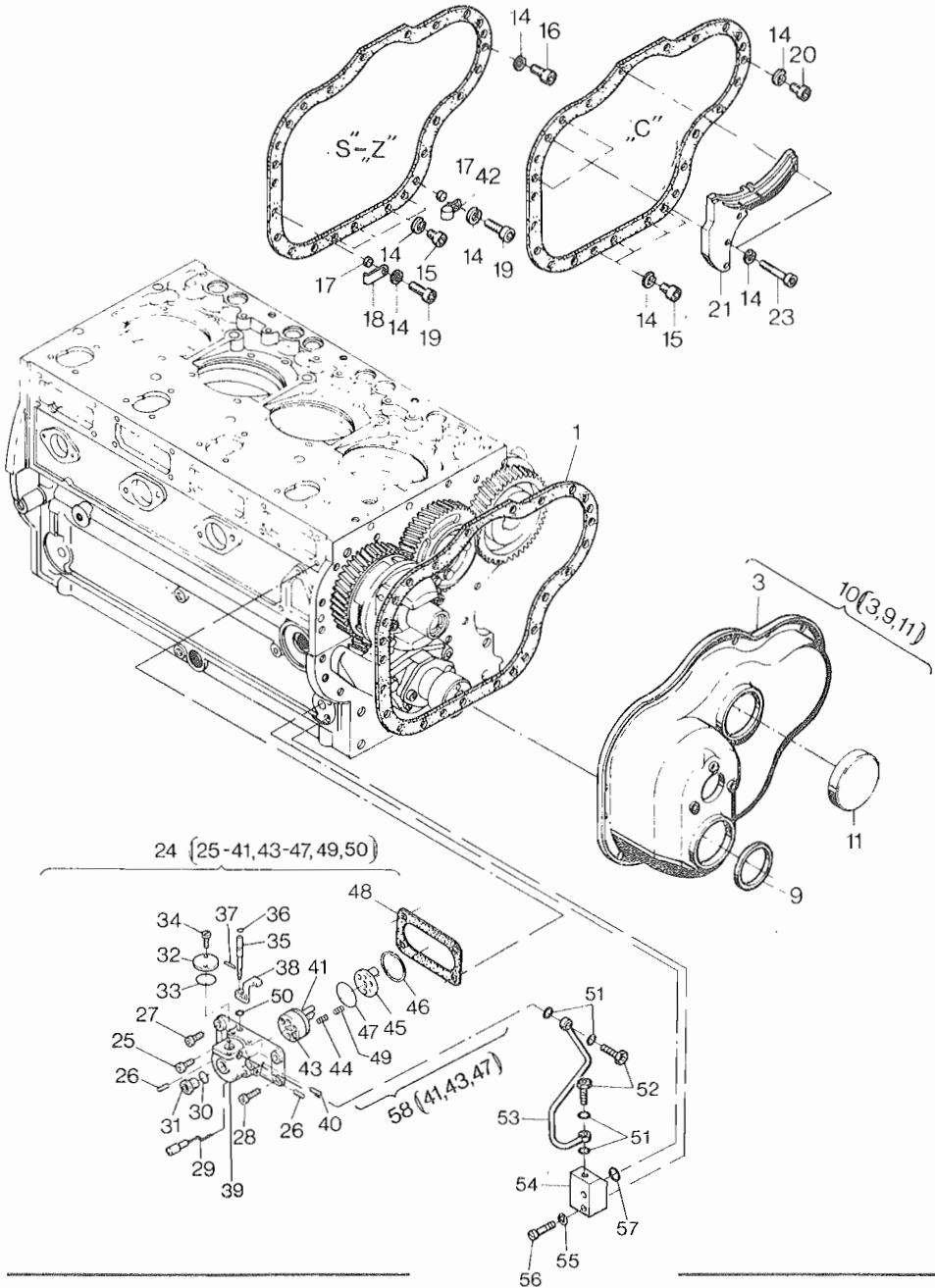

	Bestell-Nr. Ordering No. No. référence No. de pedido	Stück Quantity Quantites Cantidades		Hinweis Hints Indications Indicaciones	
		4 L 40 S/Z 4 M 40		4 L 40 C/K	
37	501 318 00	1		1	2,5 x 10 DIN 1481
38	036 702 10	1		1	
39	—	—		—	
40	500 042 00	1		1	6 x 20 DIN 915-45 H
41	—	—		—	
42	031 655 00	1		—	
43	501 543 00	1		1	7,5 x 10,5 x 1,5
44	038 811 00	3		3	
45	038 542 00	1		1	
46	500 215 00	1		1	42 x 1,75 DIN 472
47	502 631 00	1		1	37,8 x 1,5
48	036 140 00	1		1	
49	038 813 00	3		3	
50	501 172 00	1		1	4 DIN 6799
51	500 009 00	4		4	A 8 x 11,5 DIN 7603-Cu
52	500 061 00	2		2	A 2/3 DIN 7623-Zn
53	038 801 00	1		1	
54	038 806 00	1		1	
55	500 035 00	2		2	B 8 DIN 137
56	500 523 00	2		2	M 8 x 35 DIN 912-8.8
57	501 304 00	1		1	16,3 x 2,4
58	012 018 10	1		1	

Tafel Nr.
Table No.
Tableau No.
Tabla No.

12

Gebläse
Blower
Soufflerie
Ventilador

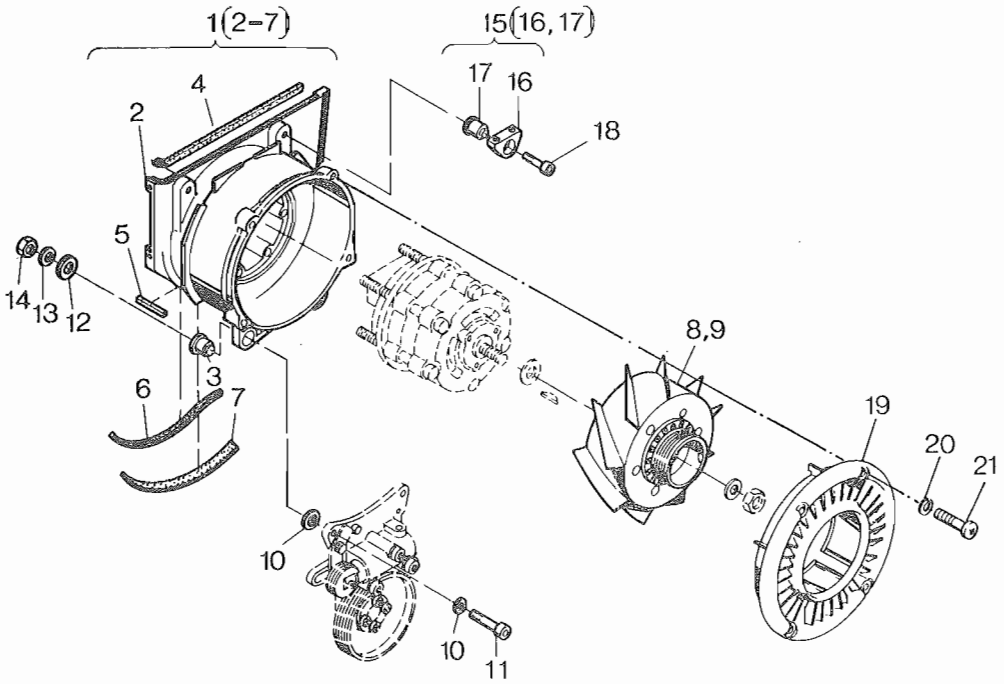

	Bestell-Nr. Ordering No. No. référence No. de pedido	Stück Quantity Quantites Cantidades				Hinweis Hints Indications Indicaciones	
			4 L30 S/Z	4L30 C/K	4 M 40 4L40 S/Z	4 L40 C/K	
1	007 402 01	1	—	—	1	—	
1	012 037 00	—	—	1	—	1	
2	—	—	—	—	—	—	
3	035 625 00	2	2	2	2	2	
4	035 526 00	1	1	1	1	1	335 mm
5	035 985 00	1	1	1	1	1	33 mm
6	035 524 01	1	1	1	1	1	240 mm
7	036 127 00	1	1	1	1	1	193 mm
8	009 351 00	1	—	—	—	—	
8	009 900 10	—	—	—	1	—	
9	009 702 00	—	—	1	—	—	
9	009 897 00	—	—	—	—	1	
10	500 617 00	4	4	4	4	4	A 10 DIN 137
11	500 551 00	2	2	2	2	2	M 10 x 55 DIN 912-8.8
12	500 706 00	2	2	2	2	2	10,5 DIN 7349
13	501 278 00	2	2	2	2	2	A 10 DIN 127
14	500 235 00	2	2	2	2	2	M 10 DIN 934-8
15	009 198 00	2	2	2	2	2	
16	—	—	—	—	—	—	
17	035 625 00	2	2	2	2	2	
18	500 526 00	2	2	2	2	2	M 8 x 45 DIN 912-8.8
19	037 628 00	—	—	1	—	1	
20	500 812 00	—	—	4	—	4	A 6 DIN 137
21	502 532 00	—	—	4	—	4	M 6x50 A3R DIN 7985-4.8

Tafel Nr.
Table No.
Tableau No.
Tabla No.

13

Einspritzausrstung
Injection equipment
Equipment d'injection
Equipo de inyeccin

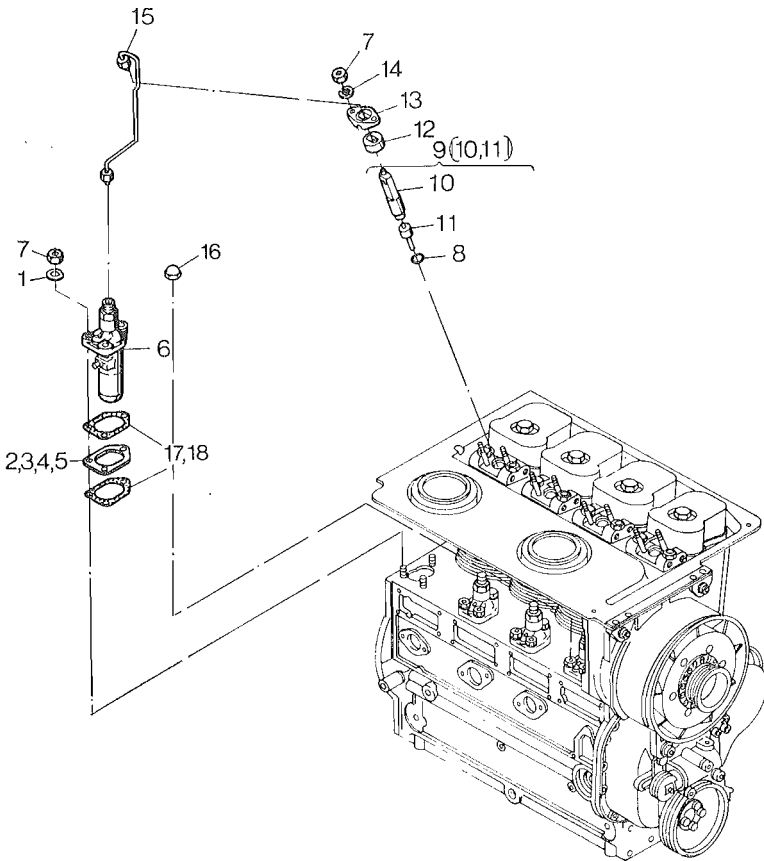

	Bestell-Nr.	Stück		Hinweis	
	Ordering No.	Quantity		Hints	
	No. référence	Quantités		Indications	
	No. de pedido	Cantidades		Indicaciones	
		4 L 30	4 L 40, 4 M 40		
1	500 035 00	—	12	B 8	DIN 137
2	031 683 01	0...4	—	0,15 mm	
2	502 739 00	—	0...8	0,30 mm	
3	031 685 00	0...4	—	0,20 mm	
3	502 738 00	—	0...8	0,60 mm	
4	031 686 00	0...4	—	0,25 mm	
4	502 737 00	—	0...4	0,90 mm	
5	031 687 00	0...4	—	0,30 mm	
5	502 736 00	—	0...4	1,20 mm	
6	501 407 10	4	—		
6	502 630 00	—	4		
7	500 229 00	19	19	M 8	DIN 934-8
8	400 850 00	4	4		
9	401 209 01	4	4		
10	—	—	—		
11	501 413 01 P1	4	4		
12	034 665 00	4	4		
13	034 605 00	4	4		
14	501 282 00	8	8	8	DIN 127
15	007 406 00	4	4	4 M 40 H	
15	012 038 00	—	4	4 M 40 L	
16	502 676 00	—	1	M 8	DIN 1587
17	031 684 00	8	—		
17	502 735 00	—	0...8	0,20 mm	
18	502 734 00	—	0...8	0,30 mm	

Tafel Nr.
Table No.
Tableau No.
Tabla No.

14

Riemenscheibe, Schwungrad, Hydr. Abstellvorrichtung
Pulley, flywheel, hydr. belt tensioner
Poulie, volant, tendeur hydr.
Polea, volante, tensor hidráulico

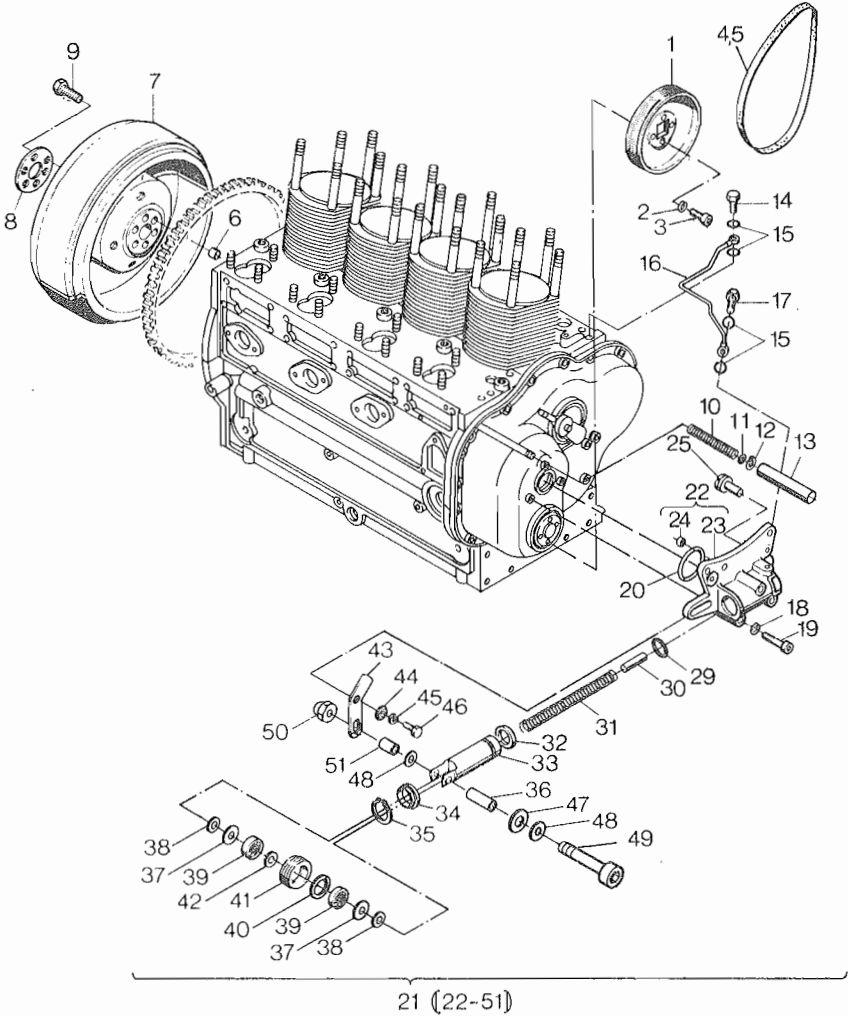

	Bestell-Nr. Ordering No. No. référence No. de pedido	Stück Quantity Quantites Cantidades				Hinweis Hints Indications Indicaciones	
		4 L30 S/Z	4L30C/K	4 M 40 4L40 S/Z	4 L40 C/K		
1	035 898 01	1	1	1	1		
2	501 282 00	4	4	4	4	8	DIN 127
3	500 519 00	4	4	4	4	M 8 x 20	DIN 931-8.8
4	501 415 00 P1	1	1	1	1	9 J 910	
5	—	—	—	—	—		
6	031 237 00	1	1	—	—		
6	036 306 00	—	—	1	1		
7	036 908 01	1	1	—	—	SAE J 620	
7	037 337 01	—	—	1	1	SAE J 620	
8	034 624 00	1	1	—	—		
8	036 458 00	—	—	1	1		
9	501 292 00	6	6	—	—	M 12 x 45	DIN 931-12.9
9	502 251 00	—	—	6	6	M 14 x 1,5 x 45	DIN 912-10.9
10	034 680 00	1	1	1	1		
11	031 332 00	1	1	1	1		
12	500 194 00	1	1	1	1	8 x 0,8	DIN 471
13	035 682 00	1	1	1	1		
14	500 061 00	1	1	1	1	A 2/3	DIN 7623
15	500 009 00	4	4	4	4	A 8	DIN 7603-Cu
16	009 100 00	1	1	1	1		
17	500 061 00	1	1	1	1		
18	500 035 00	3	3	3	3	B 8	DIN 137
19	500 818 00	3	3	3	3	M 8 x 65	DIN 912-8.8
20	501 324 01	1	1	1	1		
21	009 414 03	1	1	1	1		
22	009 276 20	1	1	1	1		
23	—	—	—	—	—		
24	400 847 00	1	1	1	1		
25	037 506 00	1	1	1	1		
26	—	—	—	—	—		
27	—	—	—	—	—		
28	—	—	—	—	—		
29	502 197 00	1	1	1	1		
30	036 393 00	1	1	1	1		
31	035 891 00	1	1	1	1		
32	502 211 00	1	1	1	1		

Tafel Nr.
Table No.
Tableau No.
Tabla No.

14

Riemenscheibe, Schwungrad, Hydr. Abstellvorrichtung
Pulley, flywheel, hydr. belt tensioner
Poulie, volant, tendeur hydr.
Polea, volante, tensor hidráulico

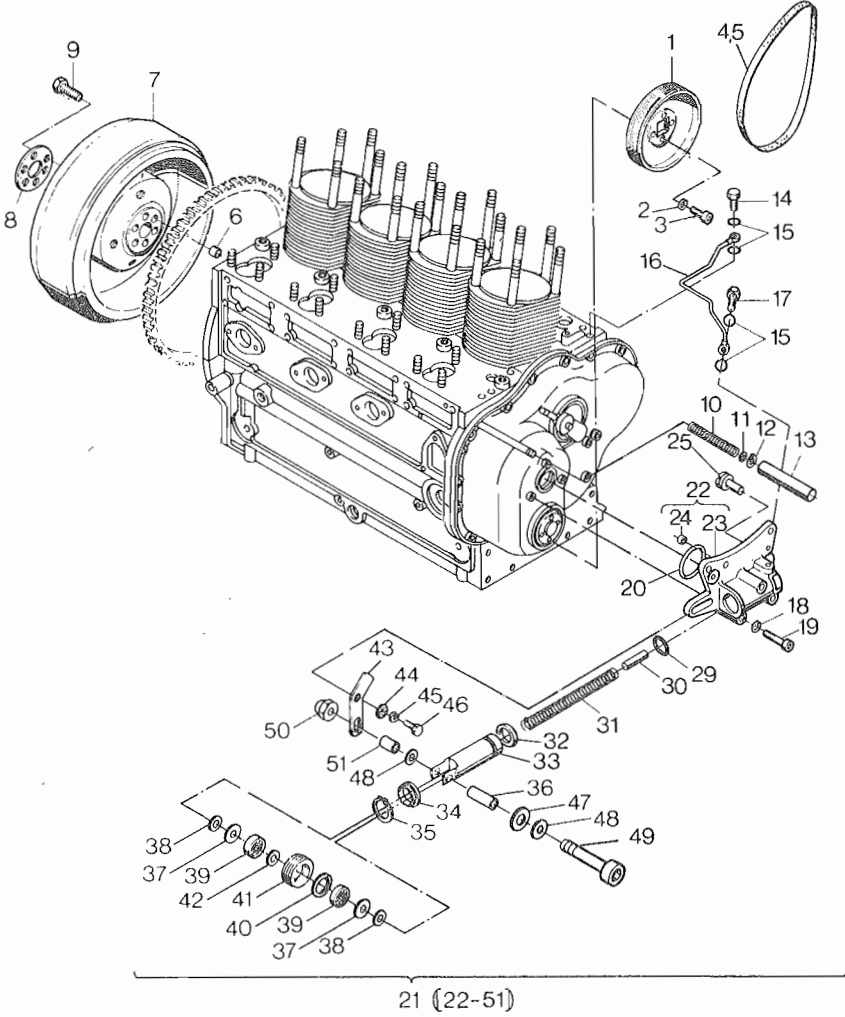

21 (22-51)

	Bestell-Nr. Ordering No. No. référence No. de pedido	Stück Quantity Quantites Cantidades				Hinweis Hints Indications Indicaciones	
		4 L30 S/Z	4 L30 C/K	4 M40 4 L40 S/Z	4 L40 C/K		
33	035 896 20	1	1	1	1		
34	036 430 00	1	1	1	1		
35	502 210 00	1	1	1	1	45 x 1,75	DIN 472
36	037 646 00	1	1	1	1		
37	502 500 00	2	2	2	2		
38	037 648 00	2	2	2	2		
39	502 499 00	2	2	2	2		
40	500 207 00	1	1	1	1	28 x 1,2	DIN 472
41	035 894 20	1	1	1	1		
42	501 321 00	1	1	1	1	12 x 18 x 1,2	
43	035 895 10	1	1	1	1		
44	035 893 00	1	1	1	1		
45	500 027 00	1	1	1	1	6	DIN 128
46	500 258 00	1	1	1	1	M 6 x 20	DIN 933-8.8
47	037 649 00	1	1	1	1		
48	500 167 00	2	2	2	2	A 8,4	DIN 125 St
49	500 818 00	1	1	1	1	M 8 x 65	DIN 912-8.8
50	400 284 00	1	1	1	1	M 8 SSN 440-8 Cu	
51	037 647 00	1	1	1	1		

Tafel Nr.
Table No.
Tableau No.
Tabla No.

15

Luftfilter, Luftansaugrohr
Air filter, air intake manifold
Filtre à air, pipe d'admission
Filtro de aire, tubo de conducción

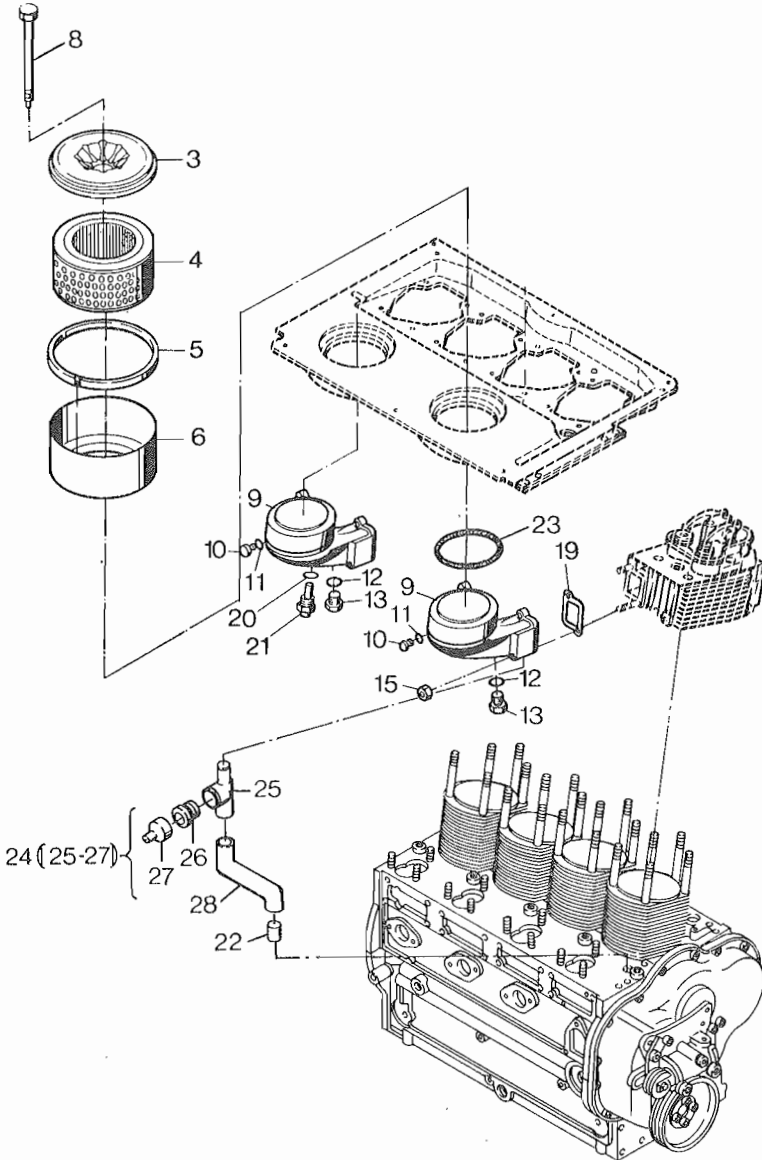

	Bestell-Nr. Ordering No. No. de pedido No. référence	Stück Quantity Quantites Cantidades		Hinweis Hints Indications Indicaciones
		4 L 30 S/Z/C/K	4 M 40 4 L 40 S/Z/C/K	
1	—	—	—	
2	—	—	—	
3	009 047 10	2	—	
3	009 530 01	—	2	
4	400 845 00 W4	2	—	
4	009 529 00 W4	—	2	
5	035 838 00 W2	2	—	
5	036 476 00 W2	—	2	
6	036 206 00	2	—	
6	036 465 00	—	2	
7	—	—	—	
8	—	—	—	
8	037 523 01	2	4	
9	035 621 04	2	—	
9	036 243 03	—	2	
10	500 623 00	2	2	M 10 x 1 DIN 908
11	500 624 00	2	2	A 10 x 13,5 DIN 7603-Cu
12	500 016 00	2	2	A 22 x 27 DIN 7603-Cu
13	501 404 00	2	2	AM 22 x 1,5 DIN 7604
14	—	—	—	
15	502 236 00	8	8	M 8 A3C
16	—	—	—	
17	—	—	—	
18	—	—	—	
19	034 615 00	4	—	
19	036 244 00	—	4	
20	—	—	—	
21	—	—	—	
22	036 490 00	1	1	
23	035 977 00	2	—	
23	036 486 00	—	2	
24	009 478 00	1	1	
25	—	—	—	
26	035 687 00	1	1	
27	035 686 00	1	1	
28	036 489 00	1	1	

Tafel Nr.
Table No.
Tableau No.
Tabla No.

16

Luftführung
Air ducting
Carter ventilation
Conducción de aire

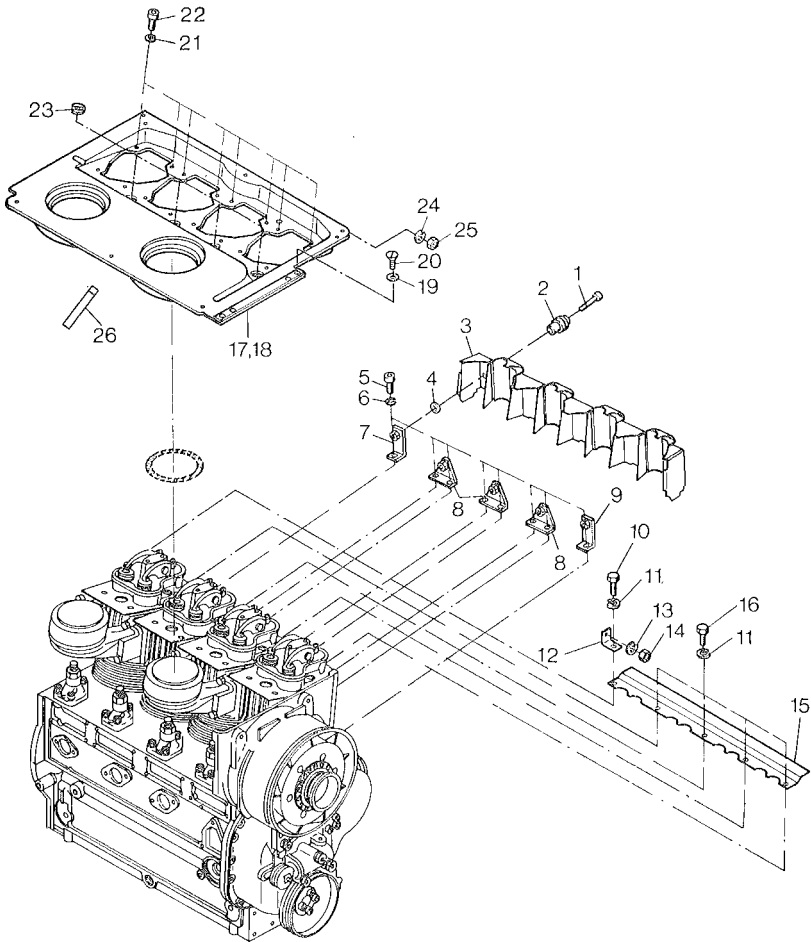

	Bestell-Nr. Ordering No. No. référence No. de pedido	Stück Quantity Quantites Cantidades				Hinweis Hints Indications Indicaciones	
		4 L30 S/Z	4L30 C/K	4 M40 4L40 S/Z	4 L40 C/K		
1	500 511 00	5	5	5	5	M 6 x 30	DIN 6912-8.8
2	009 327 00	5	5	5	5		
3	009 382 00	1	1	1	1		
4	035 755 00	5	5	5	5		
5	500 516 00	8	8	8	8	M 8 x 16	DIN 912-8.8
6	500 028 00	8	8	8	8	DIN 128	
7	009 234 00	1	1	1	1		
8	009 233 00	3	3	3	3		
9	009 235 00	1	1	1	1		
10	500 267 00	—	1	—	1	M 8 x 16	DIN 933-8.8
11	500 028 00	—	7	—	7	8	DIN 128
12	035 856 01	—	1	—	—		
13	500 812 00	—	9	—	9	A 6	DIN 137
14	500 227 00	—	7	—	7	M 6	DIN 934-8
15	035 916 01	—	1	—	—		
16	500 266 00	—	4	—	4	M 8 x 12	DIN 933-8.8
17	007 440 01	1	—	—	—		
17	009 396 01	—	—	1	—		
18	007 441 00	—	1	—	—		
18	009 398 02	—	—	—	1		
19	502 051 00	4	4	4	4	V 8,4	DIN 6797
20	502 052 00	4	4	4	4	M 8 x 16	DIN 965-8.8
21	500 812 00	8	8	8	8	A 6	DIN 137
22	500 507 00	8	8	8	8	M 6 x 16	DIN 912-8.8
23	035 927 00	4	4	4	4		
24	500 027 00	3	—	3	—	6	DIN 128
25	500 227 00	3	—	3	—	M 6	DIN 934-8
26	036 485 00	—	—	1	1		

Tafel Nr.
Table No.
Tableau No.
Tabla No.

17

Luftführung S/Z
Air ducting S/Z
Carter ventilation S/Z
Conducción de aire S/Z

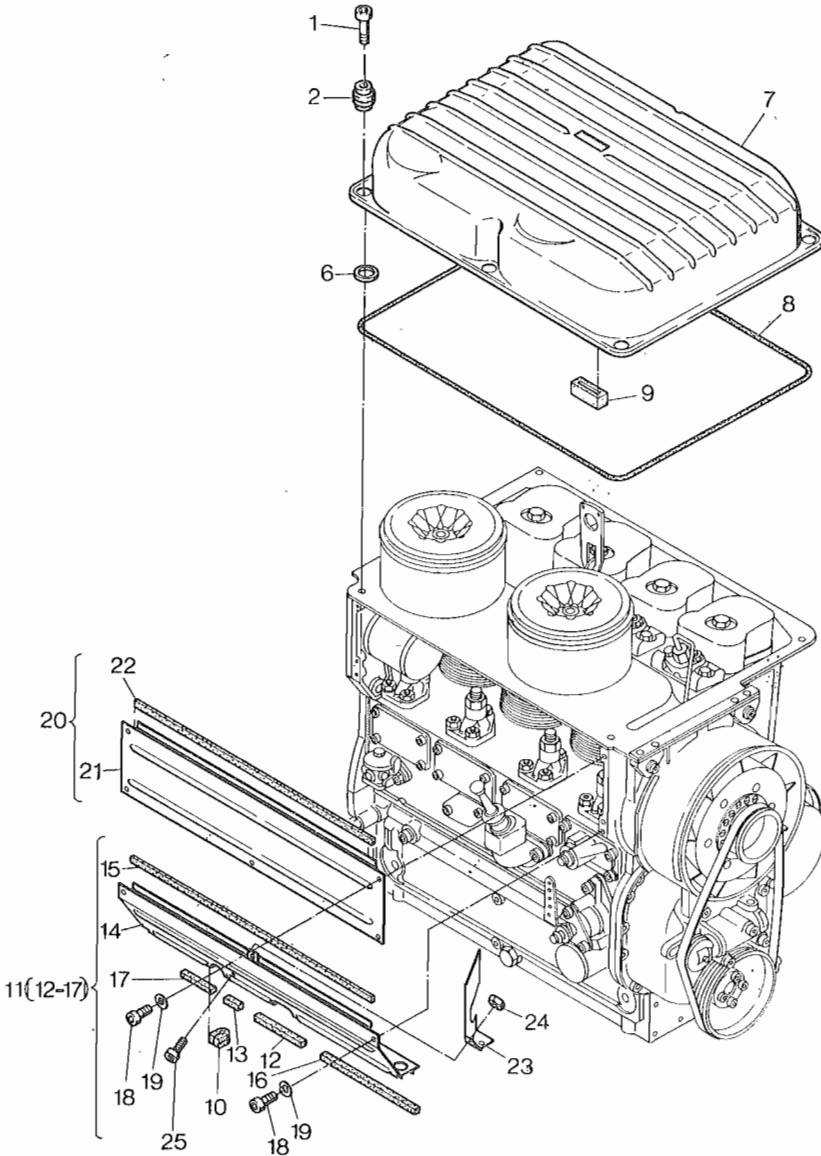

	Bestell-Nr. Ordering No. No. référence No. de pedido	Stück Quantity Quantities Cantidades			Hinweis Hints Indications Indicaciones
		4 L 30 S/Z	4 L 40 S/Z	4 M 40	
1	501 144 00	6	6	--	M 8 x 25 DIN 6912-8.8
2	009 214 00	6	6	--	
3	--	--	--	--	
4	--	--	--	--	
5	--	--	--	--	
6	035 755 00	6	6	--	
7	007 450 00	1	1	--	
8	035 694 00	1	1	--	
9	035 690 00	1	1	--	
10	035 689 00	1	1	1	
11	007 462 10	1	--	--	4 L 30 S $n \leq 1500 \text{ min}^{-1}$
11	008 067 10	1	--	--	4 L 30 S $n \leq 1500 \text{ min}^{-1}$
11	007 462 11	--	1	1	(f. Taf./Tabl. 27, Pos. 46-75)
12	035 725 01	1	1	1	97 mm
13	035 990 00	1	1	1	30 mm
14	--	--	--	--	
15	035 726 00	1	1	1	240 mm
16	035 637 01	1	1	1	214 mm
17	035 638 00	1	1	1	67 mm
18	501 330 00	8	8	8	M 6 x 12 DIN 6912-8.8
19	500 812 00	8	8	8	A 6 DIN 137
20	007 451 01	1	1	1	
21	--	--	--	--	
22	035 700 00	1	1	1	
23	036 018 00	1	1	1	
24	500 227 00	3	3	3	M 6 DIN 934-8
25	500 507 00	3	3	3	M 6 x 16 DIN 912-8.8

Tafel Nr.
Table No.
Tableau No.
Tabla No.

18

Luftführung
Air ducting
Carter ventilation
Conducción de aire

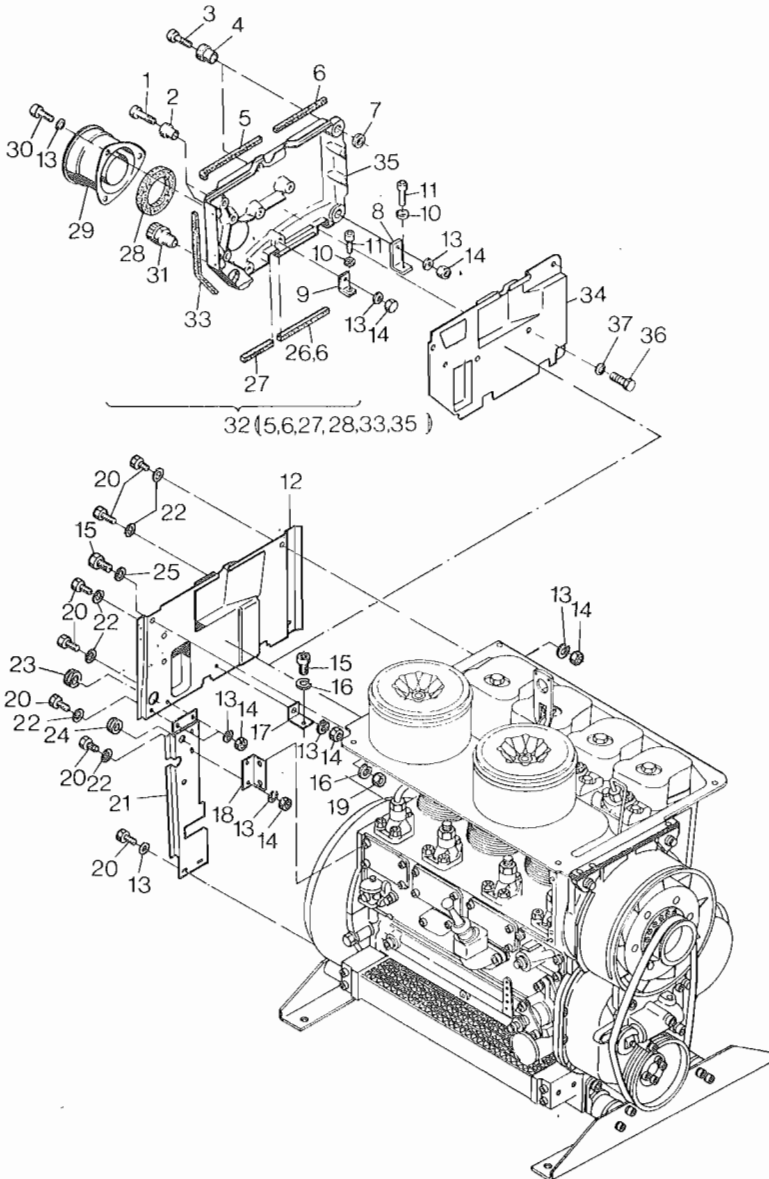

	Bestell-Nr. Ordering No. No. référence No. de pedido	Stück Quantity Quantites Cantidades				Hinweis Hints Indications Indicaciones	
		4 L30 S/Z	4L30C/K	4 M 40 4L40S/Z	4 L40 C/K		
1	500 510 00	—	—	2	2	M 6 x 30	DIN 912-8.8
2	009 327 00	—	—	2	2		
3	500 511 00	3	—	2	2	M 6 x 30	DIN 912-8.8
4	009 215 00	3	—	2	2		
5	035 601 00	1	—	—	—	210 mm	
5	035 637 01	—	—	1	1	214 mm	
6	035 600 00	1	—	—	—	117 mm	
6	035 651 00	1	—	2	2	113 mm	
7	035 755 00	3	—	4	4		
8	036 468 00	—	—	1	1		
9	035 741 00	1	—	—	—		
9	036 469 00	—	—	1	1		
10	500 028 00	1	—	2	2	8	DIN 128
11	500 516 00	1	—	2	2	M 8 x 16	DIN 912-8.8
12	009 090 02	—	1	—	—		
13	500 812 00	—	9	—	9	A 6	DIN 137
14	500 227 00	—	7	7	7	M 6	DIN 934-8
15	500 516 00	—	2	2	2	M 8 x 16	DIN 912-8.8
16	500 028 00	—	2	—	2	8	DIN 128
17	035 741 00	—	1	—	1		
18	035 901 00	—	1	—	1		
19	500 229 00	—	1	—	1	M 8	DIN 934-8
20	500 255 00	—	8	—	8	M 6 x 12	DIN 933-8.8
21	035 861 01	—	1	—	—		
21	036 472 00	—	—	—	1		
22	500 166 00	—	7	—	7	6,4	DIN 125-St
23	501 998 00	—	1	—	—		
24	035 654 00	—	1	—	1		
25	500 167 00	—	1	—	—	8,4	DIN 125-St
26	035 651 00	1	—	—	—	113 mm	
27	035 602 00	1	—	1	1	93 mm	
28	036 473 00	—	—	—	1		
29	009 537 00	—	—	1	1		
30	500 506 00	—	—	3	3	M 6 x 12	DIN 912-8.8
31	501 590 10	1	—	1	—		
32	007 415 01	1	—	—	—		

Tafel Nr.
Table No.
Tableau No.
Tabla No.

18

Luftführung
Air ducting
Carter ventilation
Conducción de aire

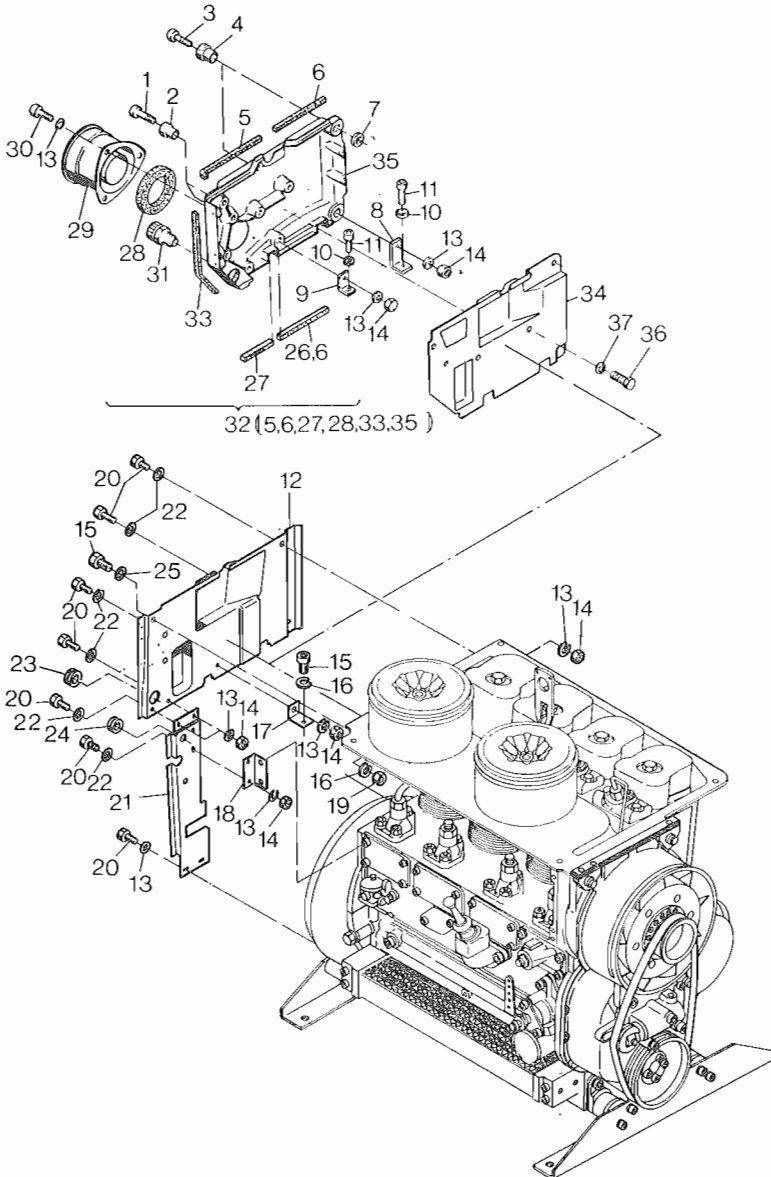

18Bestell-Nr.
Ordering No.
No. référence
No. de pedidoStück
Quantity
Quantities
CantidadesHinweis
Hints
Indications
Indicaciones4 L 30 S/Z | 4 L 30 C/K | 4 M 40
4 L 40 S/Z | 4 L 40 C/K

32	009 532 00	—	—	1	—		
32	009 535 00	—	—	—	1		
33	036 463 00	—	—	—	1		
34	036 462 01	—	—	1	1		
35	—	—	—	—	—		
36	500 255 00	—	—	7	7	M 6 x 12	DIN 933-8.8
37	500 812 00	—	—	7	7	A 6	DIN 137

Tafel Nr.
Table No.
Tableau No.
Tabla No.

19

Kapsel C/K
Capsule C/K
Capsule C/K
Cápsula C/K

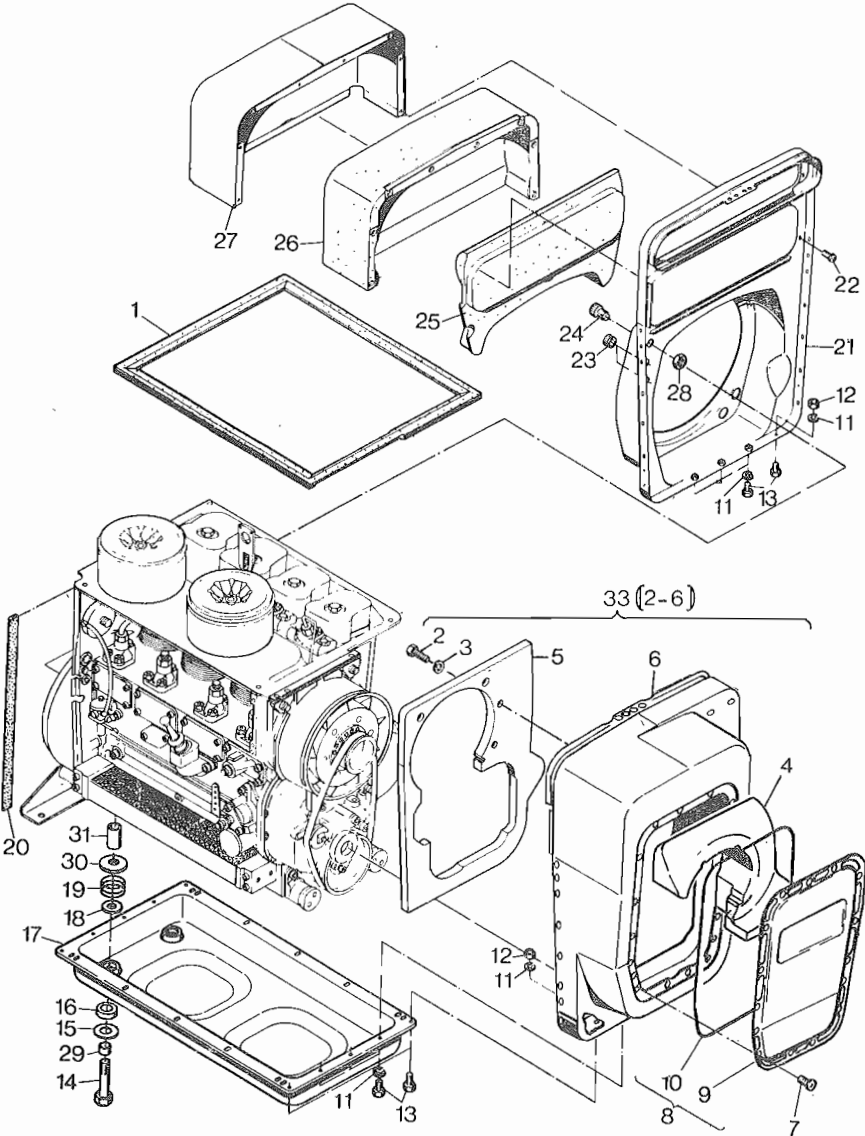

	Bestell-Nr. Ordering No. No. référence No. de pedido	Stück Quantity Quantités Cantidades		Hinweis Hints Indications Indicaciones	
		4 L 30 C/K	4 L 40 C/K		
1	036 162 00	1	1		
2	500 266 00	2	2		
3	500 028 00	2	2	M 8 x 12 8	DIN 933-8.8 DIN 128
4	009 958 00	1	1		
5	035 850 02	1	1		
6	—	—	—		
7	502 619 00	17	17	AM 6 x 10	DIN 7516-8.8 A3C
8	009 985 00	1	1		
9	—	—	—		
10	037 654 00	1	1		
11	500 812 00	10	10	A 6	DIN 137
12	500 227 00	4	4	M 6	DIN 934-8
13	500 254 00	10	10	M 6 x 10	DIN 933-8.8
14	501 430 00	4	4	M 12 x 95	DIN 931-8.8
15	036 373 00	4	4		
16	036 372 00	4	4		
17	009 220 01	1	1		
18	035 952 00	4	4		
19	035 949 00	4	4		
20	035 862 01	1	—		
20	036 433 00	—	1		
21	009 501 00	1	—		
21	009 697 00	—	1		
22	501 383 00	8	8	M 6 x 10	DIN 7985-8.8
23	035 654 00	2	2		
24	501 590 10	1	1		
25	035 872 02	1	—		
25	036 474 00	—	1		
26	035 879 01	1	1		
27	009 111 01	1	1		
28	501 591 00	1	1		
29	036 028 00	4	4		
30	036 026 00	4	4		

Tafel Nr.
Table No.
Tableau No.
Tabla No.

19

Kapsel C/K
Capsule C/K
Capsule C/K
Cápsula C/K

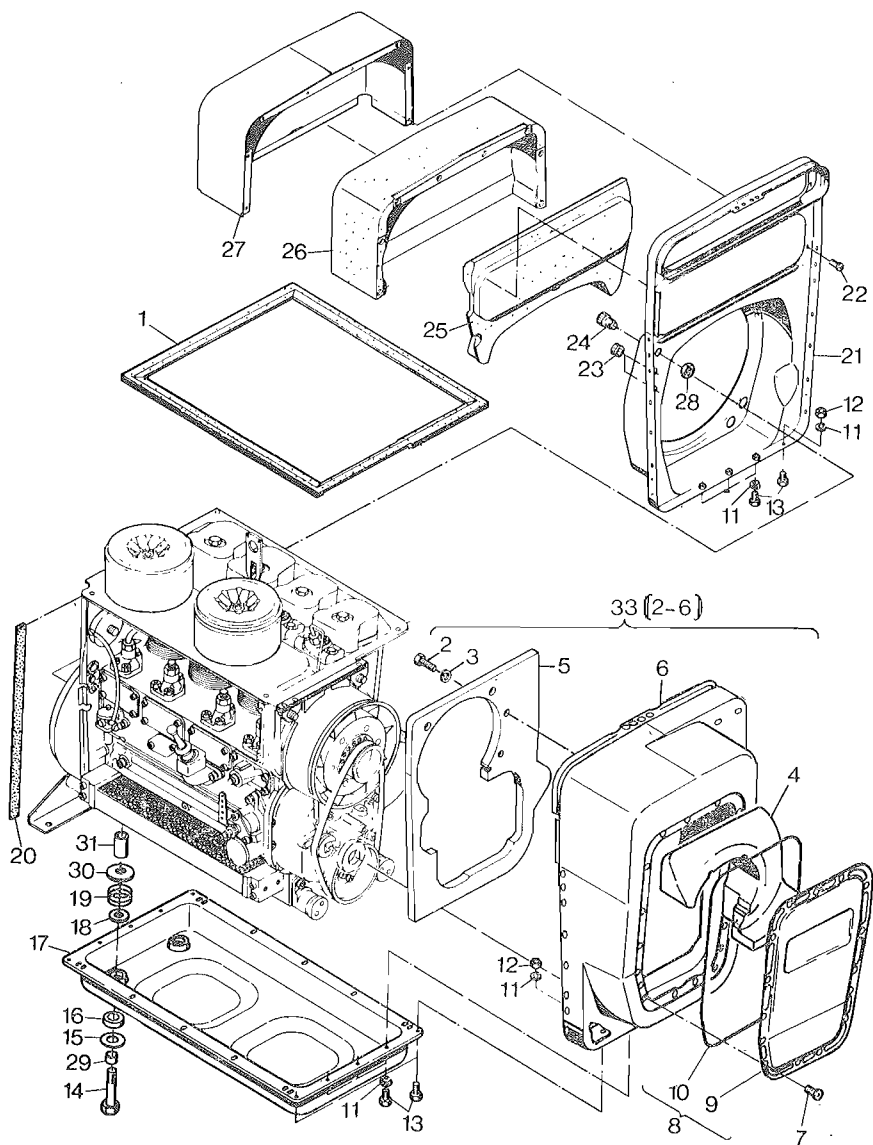

19Bestell-Nr.
Ordering No.
No. référence
No. de pedidoStück
Quantity
Quantites
CantidadesHinweis
Hints
Indications
Indicaciones

4 L.30 C/K | 4 L.40 C/K

31	036 029 00	4	4	nur bei Blechölvanne, Tafel 02, Pos. 36 only for sump, table 02/36 seulement pour carter a huile, tableau 02/36 solamente para cubeta de aceite, tabla 02/36
32	—	—	—	
33	009 503 10	1	1	

Tafel Nr.
Table No.
Tableau No.
Tabla No.

20

Kapsel – Abluftschacht 4 L 30 C/K
Capsule – air ducting 4 L 30 C/K
Capsule – carter ventilation 4 L 30 C/K
Cápsula – chapa de aire 4 L 30 C/K

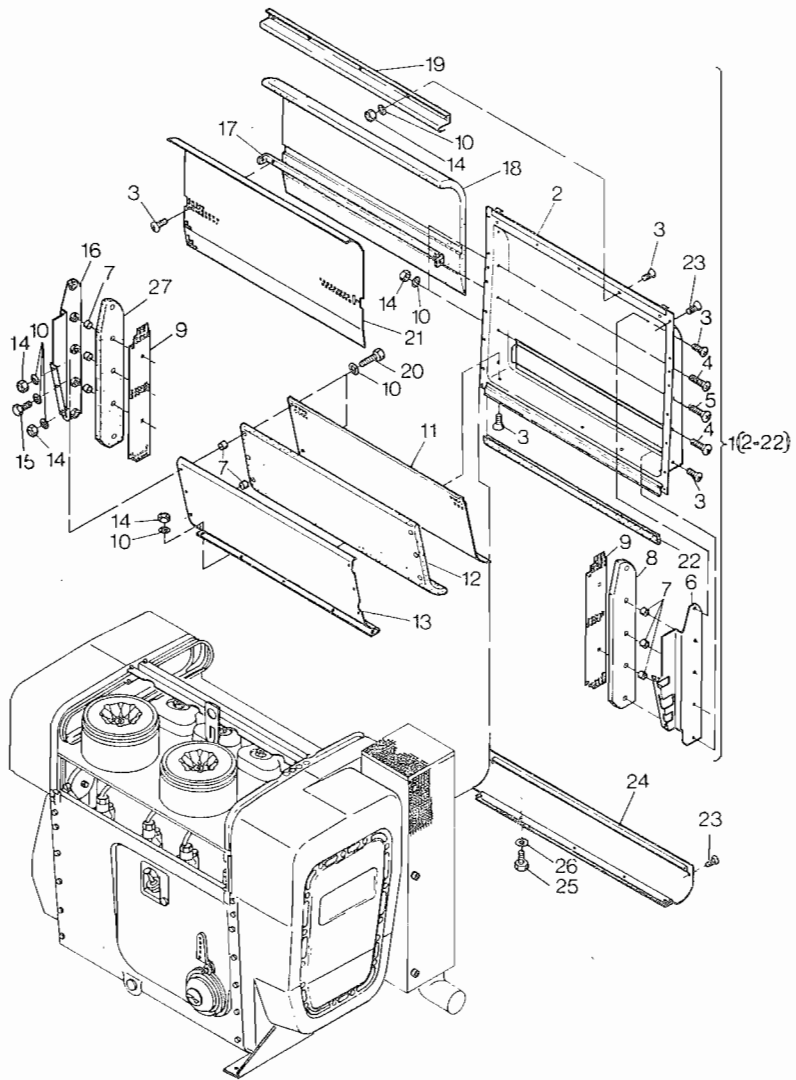

Bestell-Nr.
Ordering No.
No. référence
No. de pedido

Stück
Quantity
Quantités
Cantidades

Hinweis
Hints
Indications
Indicaciones

4 L.30 C/K

1	009 258 01	1		
2	009 071 01	1		
3	502 618 00	15	M 6 x 10	DIN 7985-8.8 A3R
4	501 385 00	4	M 6 x 30	DIN 7985-8.8
5	501 386 00	2	M 6 x 35	DIN 7985-5.6
6	009 084 01	1		
7	035 905 00	10		
8	035 871 01	1		
9	035 908 01	2		
10	500 166 00	26	6,4	DIN 125-St
11	035 918 00	1		
12	035 878 00	1		
13	009 082 00	1		
14	500 227 00	20	M 6	DIN 934-8
15	500 255 00	2	M 6 x 12	DIN 933-8.8
16	009 083 01	1		
17	035 914 00	1		
18	035 875 00	1		
19	035 849 00	1		
20	500 261 00	4	M 6 x 30	DIN 933-8.8
21	035 919 00	1		
22	035 935 00	1		
23	502 618 00	14	M 6 x 10	DIN 7985-8.8 A3R
24	009 502 00	1		
25	500 254 00	5	M 6 x 10	DIN 933-8.8
26	500 166 00	5	6,4	DIN 125-St
27	037 504 01	1		

Tafel Nr.
Table No.
Tableau No.
Tabla No.

21

Kapsel — Abluftschacht 4 L 40 C/K
Capsule — air ducting 4 L 40 C/K
Capsule — carter ventilation 4 L 40 C/K
Cápsula — chapa de aire 4 L 40 C/K

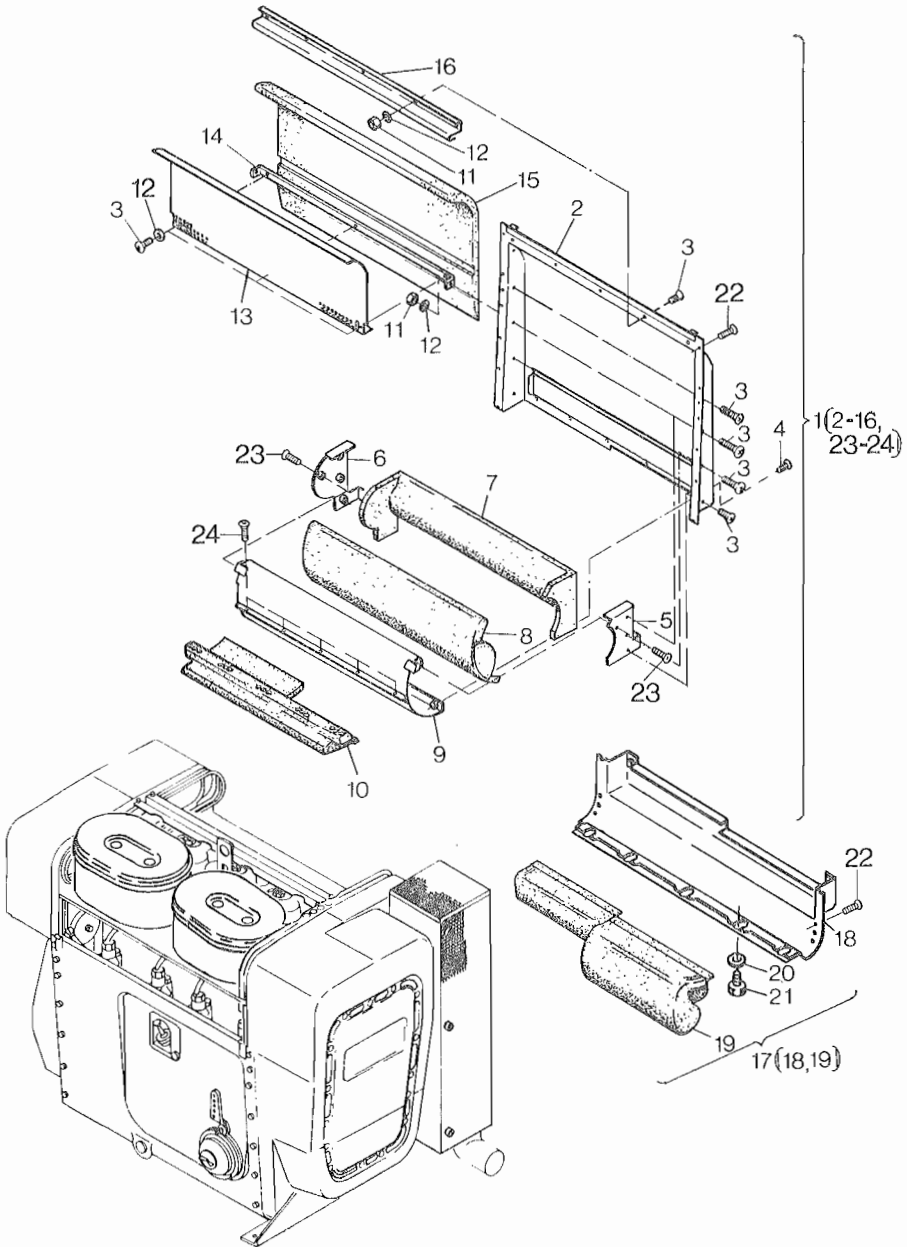

21

	Bestell-Nr. Ordering No. No. référence No. de pedido	Stück Quantity Quantites Cantidades	Hinweis Hints Indications Indicaciones
4 L 40 C/K			
1	009 968 01	1	
2	009 960 00	1	
3	502 618 00	16	M 6 x 10 DIN 7985-8.8 A3R
4	500 493 00	7	M 5 x 10 DIN 7985-8.8
5	009 962 00	1	
6	009 963 00	1	
7	037 674 00	1	
8	037 688 00	1	
9	009 964 00	1	
10	012 055 00	1	
11	500 227 00	7	M 6 DIN 934-8
12	500 166 00	10	6,4 DIN 125-St
13	037 684 00	1	
14	037 683 00	1	
15	037 690 00	1	
16	037 677 00	1	
17	009 949 00	1	
18	—	—	
19	037 673 00	1	
20	500 166 00	5	6,4 DIN 125-St
21	500 254 00	5	M 6 x 10 DIN 933-8.8
22	502 618 00	14	M 6 x 10 DIN 7985-8.8
23	500 493 00	2	M 5 x 10 DIN 7985-8.8
24	500 493 00	5	M 5 x 10 DIN 7985-8.8

Tafel Nr.
Table No.
Tableau No.
Tabla No.

22

Kapsel C/K
Capsule C/K
Capsule C/K
Cápsula C/K

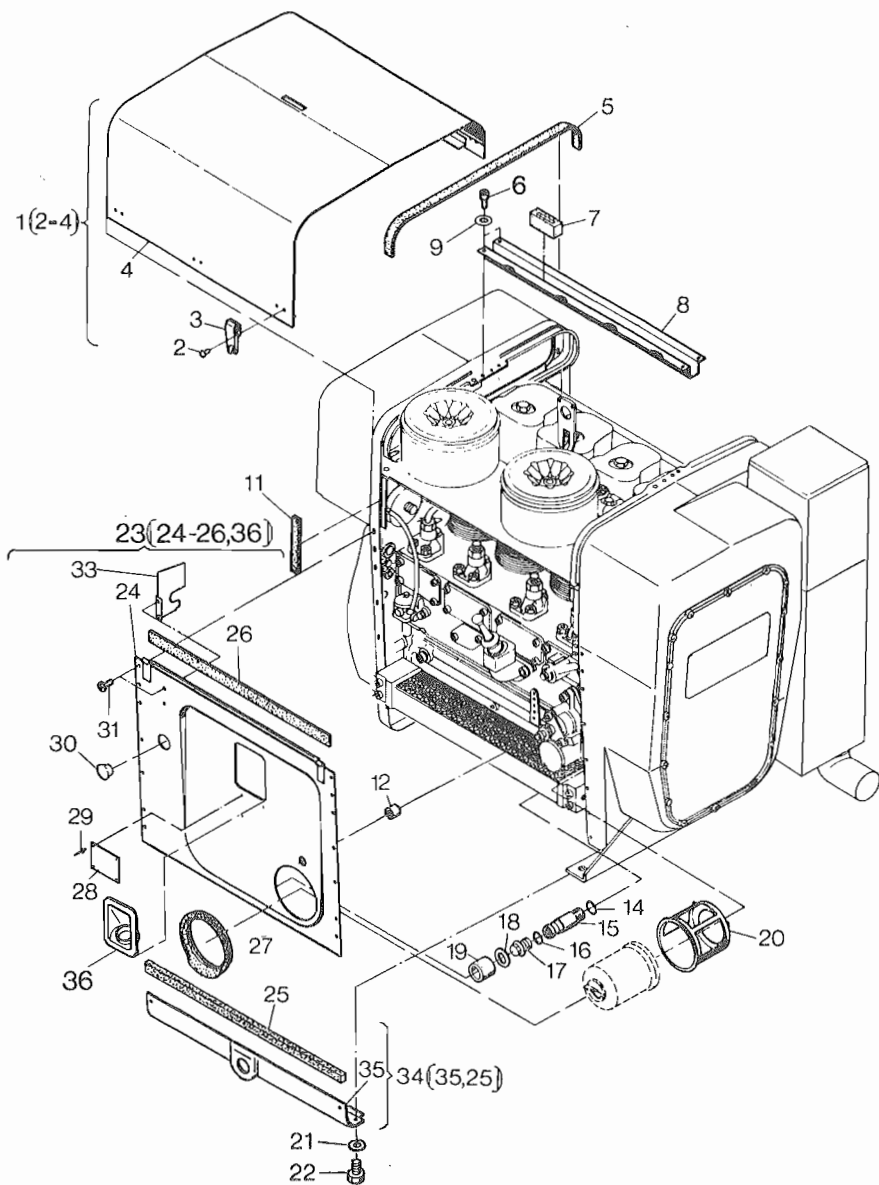

	Bestell-Nr. Ordering No. No. référence No. de pedido	Stück Quantity Quantites Cantidades	Hinweis Hints Indications Indicaciones
4 L.30 C/K, 4 L.40 C/K			
1	009 069 00	1	
2	502 373 00	12	5 x 10 DIN 660 - UST 36-2
3	401 213 00	6	
4	—	—	
5	035 776 00	2	
6	501 330 00	4	M 6 x 12 DIN 6912-8.8
7	035 690 00	1	
8	035 827 00	1	
9	500 812 00	4	A 6 DIN 137
10	—	—	
11	035 772 00	2	
12	035 794 00	1	
13	—	—	
14	500 016 00 W4	1	A 22 x 27 DIN 7603-Cu
15	500 505 00	1	
16	500 014 00 W4	1	A 18 x 22 DIN 7603-Cu
17	500 442 00 W1	1	M 18 x 1,5 DIN 910
18	035 923 00	1	
19	035 795 00	1	
20	009 243 00	1	
21	500 166 00	5	6,4 DIN 125-St
22	500 254 00	5	M 6 x 10 DIN 933-8.8
23	009 355 10	1	
24	—	—	
25	036 239 10	1	
26	035 935 00	1	
27	035 940 01	1	
28	036 396 00	1	
29	400 025 00	4	
30	037 693 00	1	
31	502 618 00	14	M 6 x 10 DIN 7985-8.8 A3R
32	—	—	
33	036 020 00	1	
34	009 743 01	1	
35	—	—	
36	037 614 00	1	

Tafel Nr.
Table No.
Tableau No.
Tabla No.

23

Kraftstoff
Fuel
Carburant
Combustible

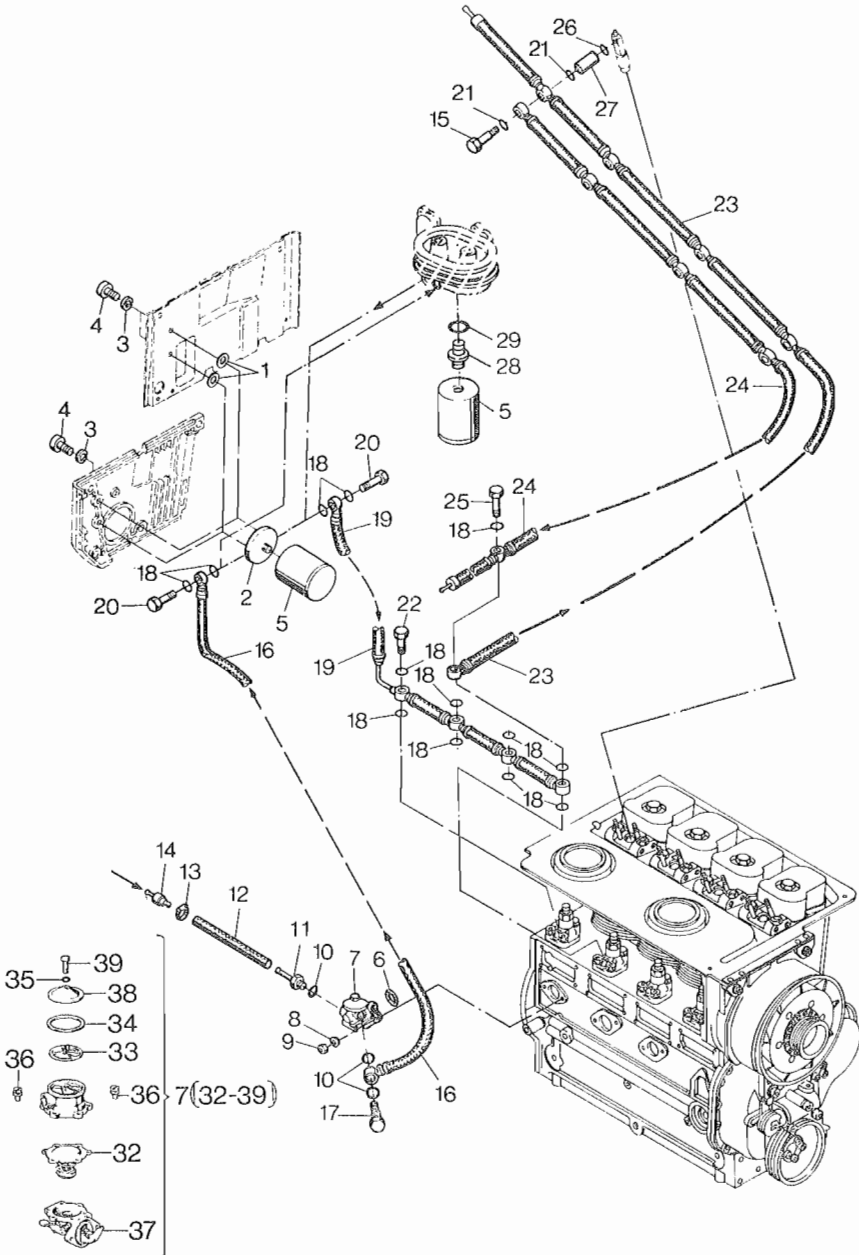

	Bestell-Nr. Ordering No. No. référence No. de pedido	Stück Quantity Quantites Cantidades				Hinweis Hints Indications Indicaciones	
		4 L30 S/Z	4L30 C/K	4 M 40 4L40 S/Z	4 L40 C/K		
1	501 230 00	—	2	—	—		
2	035 677 00	1	1	—	—		
3	500 028 00	2	2	—	—	DIN 128	
4	500 516 00	2	2	—	—	M 8 x 16	DIN 912-8.8
5	401 203 00 W2	1	1	—	—		
5	502 515 00 W2	—	—	1	1		
6	501 299 00	1	1	1	1		
7	401 204 00	1	1	1	1		
8	500 812 00	2	2	2	2	A 6	DIN 137
9	500 227 00	2	2	2	2	M 6	DIN 934-8
10	500 012 00	3	3	3	3	A 14 x 18	DIN 7603-Cu
11	034 668 00	1	1	1	1		
12	034 933 00	1	1	1	1		
13	400 261 00	1	1	1	1		
14	036 581 00	1	1	1	1		
15	034 602 00	4	4	4	4		
16	035 733 01	1	1	1	1		
17	500 064 00	1	1	1	1	A 8	DIN 7623
18	500 011 00	13	13	13	13	A 12 x 15,5	DIN 7603-Cu
19	035 696 00	1	1	—	—		
19	038 367 00	—	—	1	1		
20	500 063 00	2	2	2	2	A 6	DIN 7603-Cu
21	500 009 00	8	8	8	8	A 8 x 11,5	DIN 7603-Cu
22	036 134 00	2	2	2	2		
23	008 060 00	1	—	1	—		
24	008 025 00	—	1	—	1		
25	036 397 00	1	1	—	—		
25	038 906 00	—	—	1	1		
26	500 008 00	4	4	4	4	A 6,5 x 9,5	DIN 7603-Cu
27	035 739 00	4	4	4	4		
28	502 533 00	—	—	1	1	A LL 10	DIN 7647
29	500 012 00	—	—	1	1	A 14 x 18	DIN 7603 Cu
32	490 182 00	1	1	1	1		
33	490 183 00	1	1	1	1		
34	490 184 00	1	1	1	1		
35	490 185 00	1	1	1	1		
36	490 181 00	6	6	6	6		
37	—	—	—	—	—		
38	—	—	—	—	—		
39	—	—	—	—	—		

Tafel Nr.
Table No.
Tableau No.
Tabla No.

24

Auspuff S/Z
Exhaust S/Z
Echappement S/Z
Escape S/Z

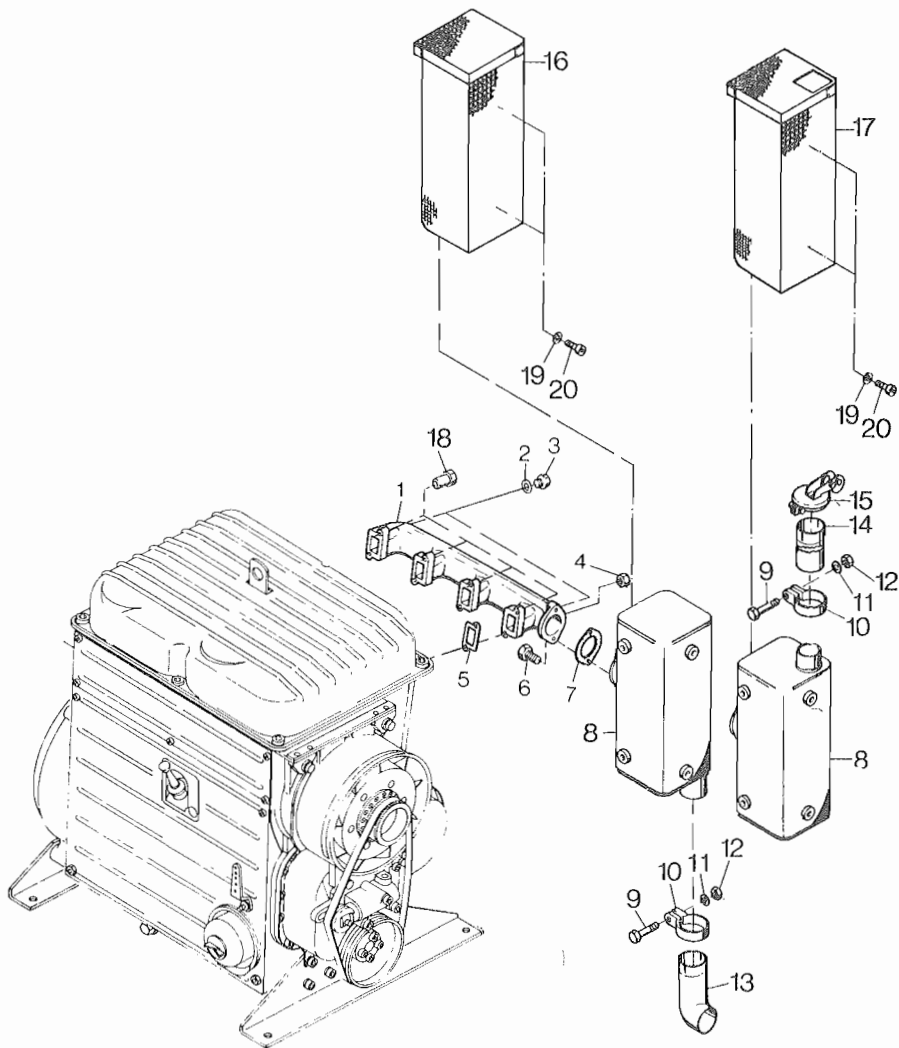

	Bestell-Nr. Ordering No. No. référence No. de pedido	Stück Quantity Quantites Cantidades		Hinweis Hints Indications Indicaciones	
		4 L 30 S/Z	4 M 40 4 L 40 S/Z		
1	035 521 00	1	—		
1	036 320 00	—	1		
2	032 288 00	4	4		
3	500 447 00	4	4	R 1/4	DIN 910
4	400 284 00	8	4	M 8	SSN 440-8 Cu
5	034 615 00	4	—		
5	036 245 00	—	4		
6	502 250 00	2	2	M 10 x 30	DIN 912-10.9 C4P
7	501 659 01	5	5		
8	038 834 00	1	1		
9	500 299 00	1	1	M 10 x 55	DIN 931-8.8
10	038 778 00	1	1		
11	500 169 00	1	1	8,4	DIN 125-St
12	400 286 00	1	1	M 10	SSN 440-8 Cu
13	038 856 00	1	1		
14	038 896 00	1	1		
15	501 569 00	1	1		
16	010 914 00	1	1		
17	038 858 00	1	1	8	DIN 128
18	036 252 00	—	4		
19	501 200 00	6	6	A 6,4	DIN 9021-St A3C
20	501 390 00	6	6	M 6 x 10	DIN 912-8.8 C4P

Tafel Nr.
Table No.
Tableau No.
Tabla No.

25

Auspuff C/K
Exhaust C/K
Echappement C/K
Escape C/K

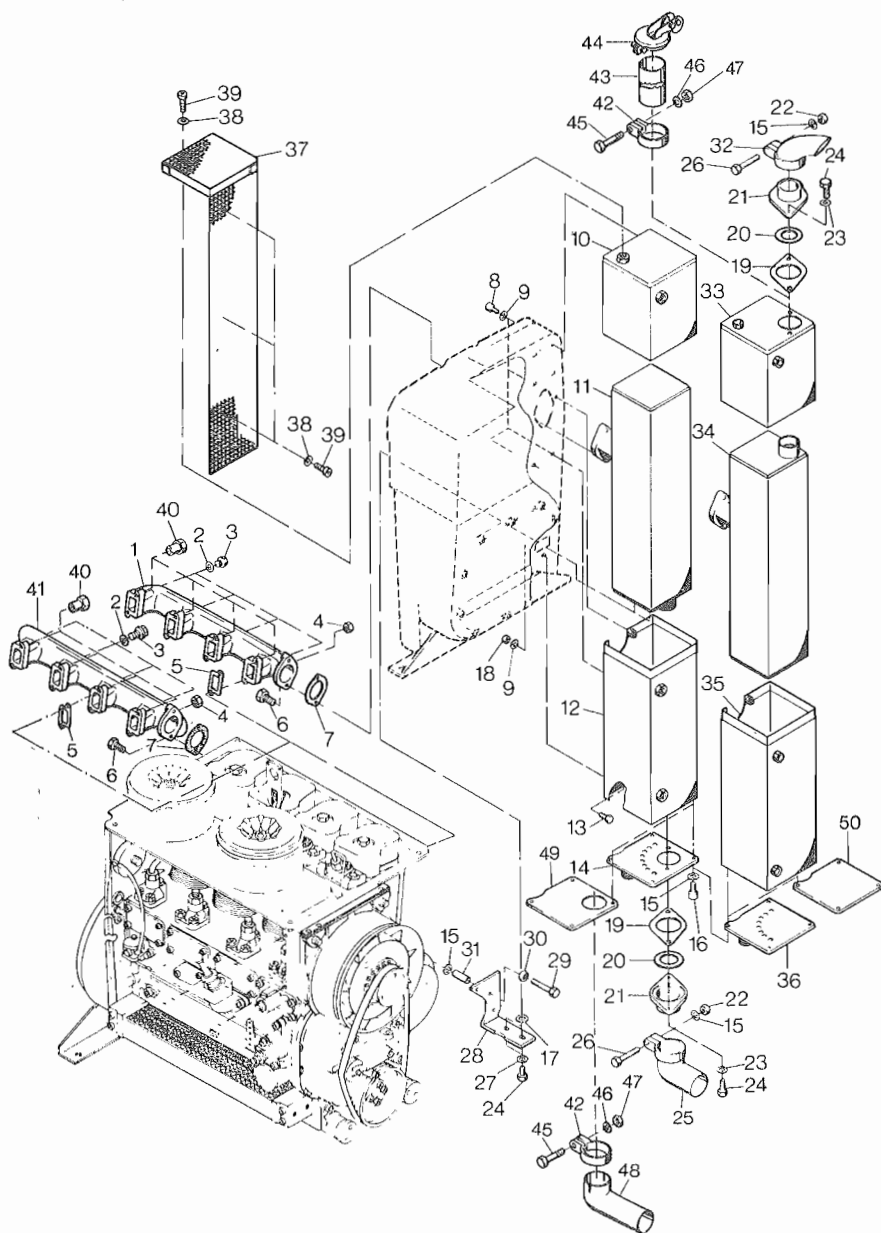

Bestell-Nr.
Ordering No.
No. référence
No. de pedido

Stück
Quantity
Quantites
Cantidades

Hinweis
Hints
Indications
Indicaciones

4 L 30 C/K | 4 L 40 C/K

		4 L 30 C/K	4 L 40 C/K		
1	035 521 00	1	—		
1	036 320 00	—	1		
2	032 288 00	4	4		
3	500 447 00	4	4	R 1/4	DIN 910
4	400 284 00	8	4	M 8	SSN 440-8 Cu
5	034 615 00	4	—		
5	036 245 00	—	4		
6	501 433 00	2	—	M 10 x 35	DIN 933-8.8
6	502 250 00	—	2	M 10 x 30	DIN 912-10.9 C4P
7	501 659 01	5	5		
8	502 557 00	7	7	M 6 x 12	DIN 912-8.8 C4A
9	500 027 00	7	7	6	DIN 128
10	009 029 01	1	1		
11	037 093 00	1	—		
11	038 299 01	—	1		
12	008 718 01	—	1		
12	009 031 02	1	—		
13	500 255 00	1	1	M 6 x 12	DIN 933-8.8
14	009 032 02	1	—		
15	500 167 00	8	8	8,4	DIN 125-St
16	501 389 00	4	4	M 8 x 12	DIN 912-8.8
17	032 131 00	6	6		
18	500 227 00	1	1	M 6	DIN 934-8
19	036 288 00	1	—		
20	036 153 01	1	—		
21	036 287 00	1	—		
22	400 284 00	1	1	M 8	SSN 440-8 Cu
23	500 035 00	2	—	B 8	DIN 137
24	501 376 00	4	2	M 8 x 20	DIN 933-8.8 C4P
25	008 733 00	1	—		
26	500 284 00	1	—	M 8 x 60	DIN 931-8.8
27	500 629 00	2	2	B 8,4	DIN 9021-50
28	035 386 01	1	1		
29	500 879 00	3	3	M 8 x 70	DIN 931-8.8
30	500 028 00	3	3	8	DIN 128
31	035 387 01	3	3		

Tafel Nr.
Table No.
Tableau No.
Tabla No.

25

Auspuff C/K
Exhaust C/K
Echappement C/K
Escape C/K

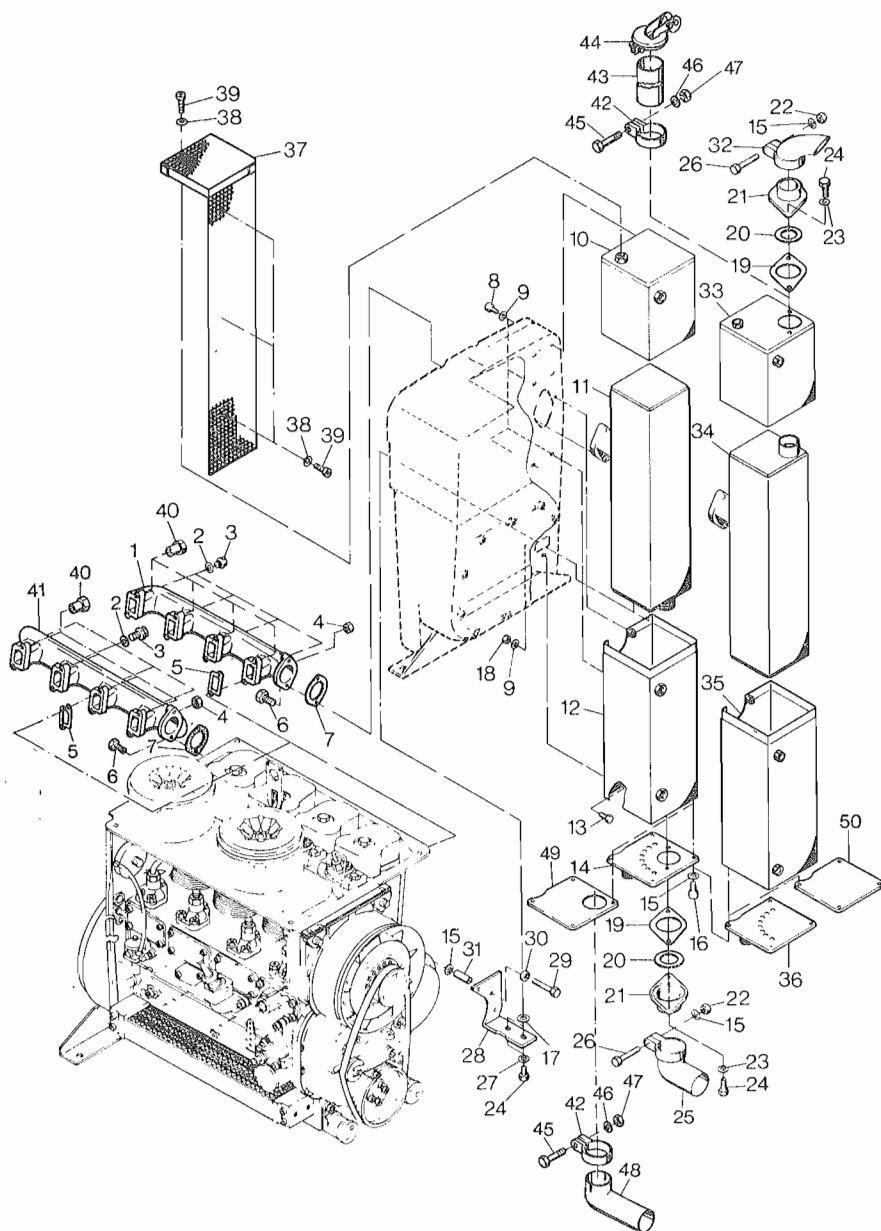

	Bestell-Nr. Ordering No. No. référence No. de pedido	Stück Quantity Quantites Cantidades		Hinweis Hints Indications Indicaciones	
		4 L 30 C/K	4 L 40 C/K		
32	008 732 00	1	—		
33	010 830 00	—	1		
33	008 715 01	1	—		
34	037 167 01	1	—		
34	038 838 00	—	1		
35	008 718 01	1	1		
36	008 719 00	1	—		
37	008 492 00	1	1		
38	501 200 00	7	7	A 6,4	DIN 9021-St Zn
39	501 390 00	7	7	M 6 x 10	DIN 912-8.8 C4P
40	036 252 00	—	4		
41	037 686 00	—	1		
42	038 778 00	—	1	58,5	
42	038 777 00	—	1	52,5	
43	038 897 00	—	1		
44	502 797 00	—	1		
45	500 299 00	—	1	M 10 x 55	DIN 125-St
46	500 169 00	—	1	B 10,5	DIN 125-St
47	400 286 00	—	1	SSN 440-8 Cu	
48	038 776 00	—	1	58,5	
49	038 779 00	—	1		
50	038 780 00	—	1		

Tafel Nr.
Table No.
Tableau No.
Tabla No.

26

Starter, Generator
Starter, alternator
Demarreur, alternateur
Arrancador, alternador

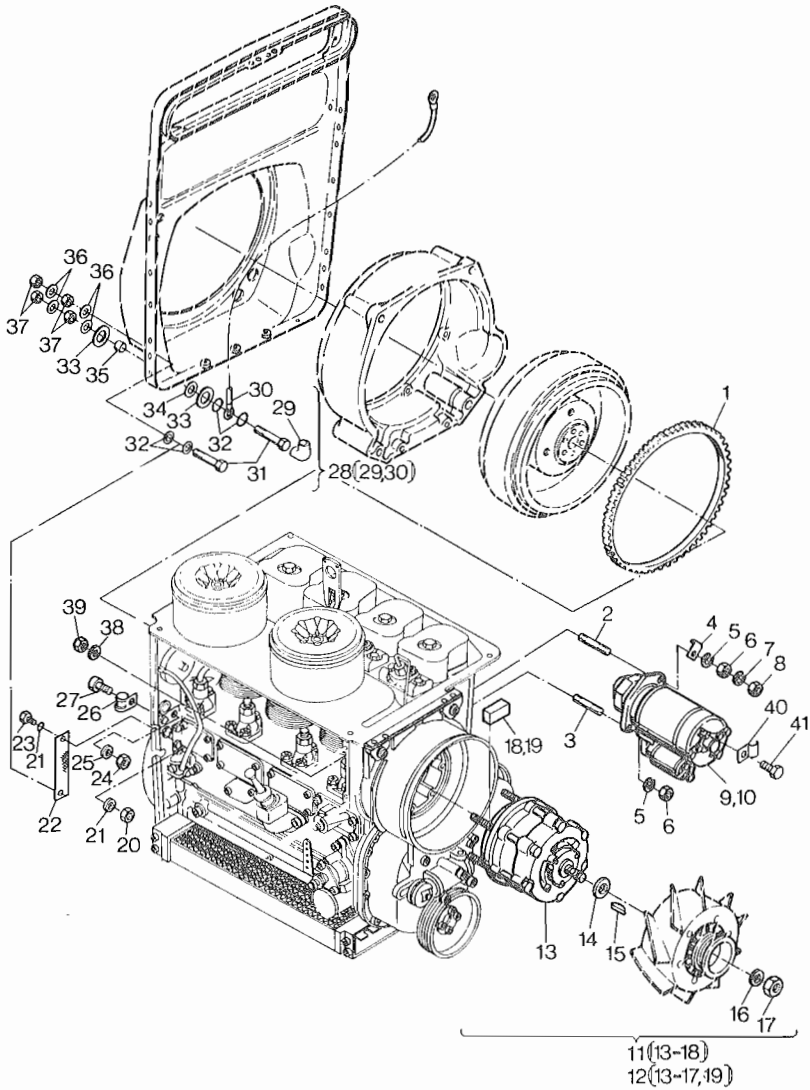

	Bestell-Nr. Ordering No. No. référence No. de pedido	Stück Quantity Quantités Cantidades		Hinweis Hints Indications Indicaciones	
		4 L 30 S/Z 4 L 40 S/Z 4 M 40		4 L 30 C/K 4 L 40 C/K	
1	031 561 01	1		1	
2	032 868 00	1		1	
3	500 423 00	1		1	M 12 x 25 DIN 938-5.6
4	036 896 00	—		1	
5	500 030 00	2		2	12 DIN 128
6	500 239 00	2		2	M 12 DIN 934-8
7	500 632 00	1		—	12
8	500 635 00	1		—	M 12 DIN 936-5 GAL
9	501 835 00	1		1	12 V 2,7 KW
10	501 954 00	1		1	24 V 4,0 KW
11	401 210 01	1		1	14 V 55 A
12	501 649 01	1		1	28 V 45 A
13	—	—		—	
14	—	—		—	
15	500 178 00	1		1	4 x 6,5 DIN 6888
16	—	—		—	
17	490 536 00	1		1	
18	490 387 00	1		1	12 V
19	490 388 00	1		1	24 V
20	500 229 00	—		1	M 8 DIN 934-8
21	500 167 00	—		2	8,4 DIN 125-St
22	036 928 00	—		1	
23	500 267 00	—		1	M 8 x 16 DIN 933-8.8
24	500 227 00	—		2	M 6 DIN 934-8
25	500 812 00	—		2	A 6 DIN 137
26	501 584 00	—		2	
27	500 507 00	—		2	M 6 x 16 DIN 912-8.8
28	008 173 00	—		1	
29	400 266 00	—		1	
30	—	—		—	
31	500 274 00	—		2	M 8 x 30 DIN 933-MS
32	501 799 00	—		4	J 8,2 Zn DIN 6797
33	038 141 00	—		2	
34	501 798 00	—		1	A 10,5 Zn DIN 6797
35	038 142 00	—		1	
36	500 168 00	—		4	8,4 DIN 125-MS

Tafel Nr.
Table No.
Tableau No.
Tabla No.

26

Starter, Generator
Starter, alternator
Demarreur, alternateur
Arrancador, alternador

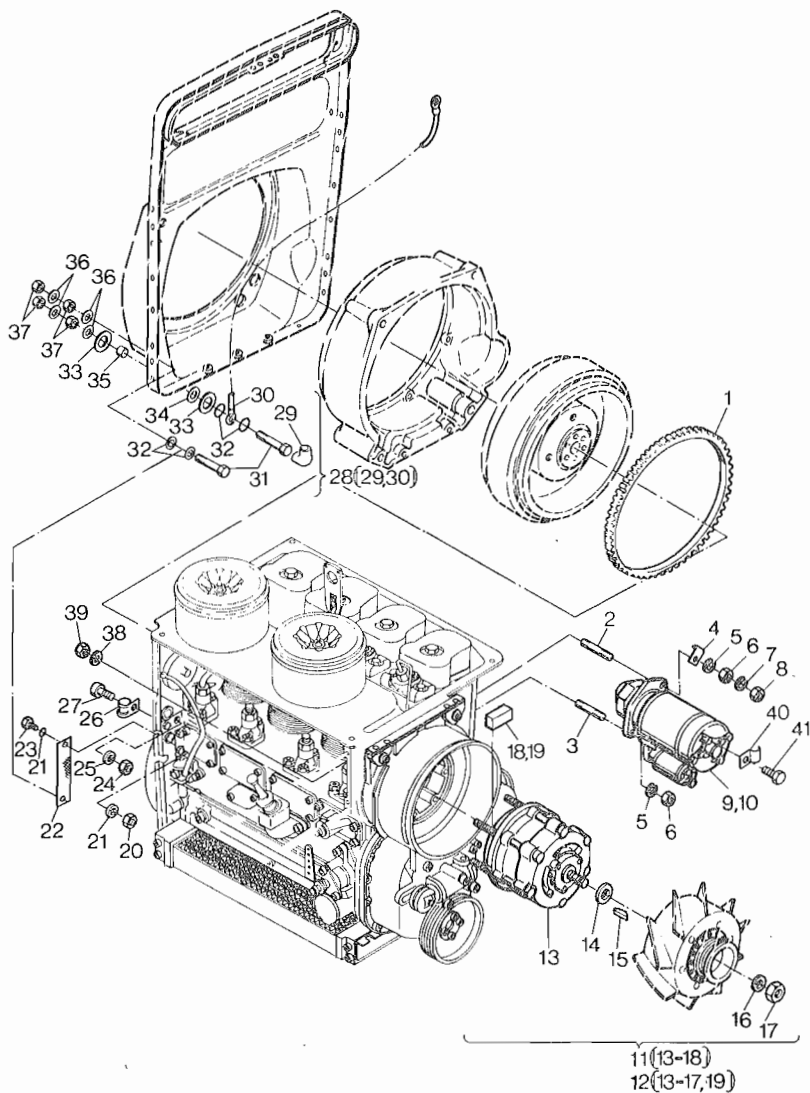

26

Bestell-Nr. Ordering No. No. référence No. de pedido	Stück Quantity Quantities Cantidades	Hinweis Hints Indications Indicaciones
---	---	---

4 L 30 S/Z	4 L 30 C/K
4 L 40 S/Z	4 L 40 C/K
4 M 40	

37	500 230 00	—	4	M 8	DIN 934-MS
38	500 812 00	6	6	A 6	DIN 137 A3C
39	501 444 00	6	6	M 6	DIN 934-8 A3C
40	501 584 00	1	1		
41	501 655 00	1	1	M 6 x 12	DIN 933-8.8 A3C

Tafel Nr.
Table No. **27**
Tableau No.
Tabla No.

Armaturen
Electric equipment
Équipement électrique
Equipo eléctrico

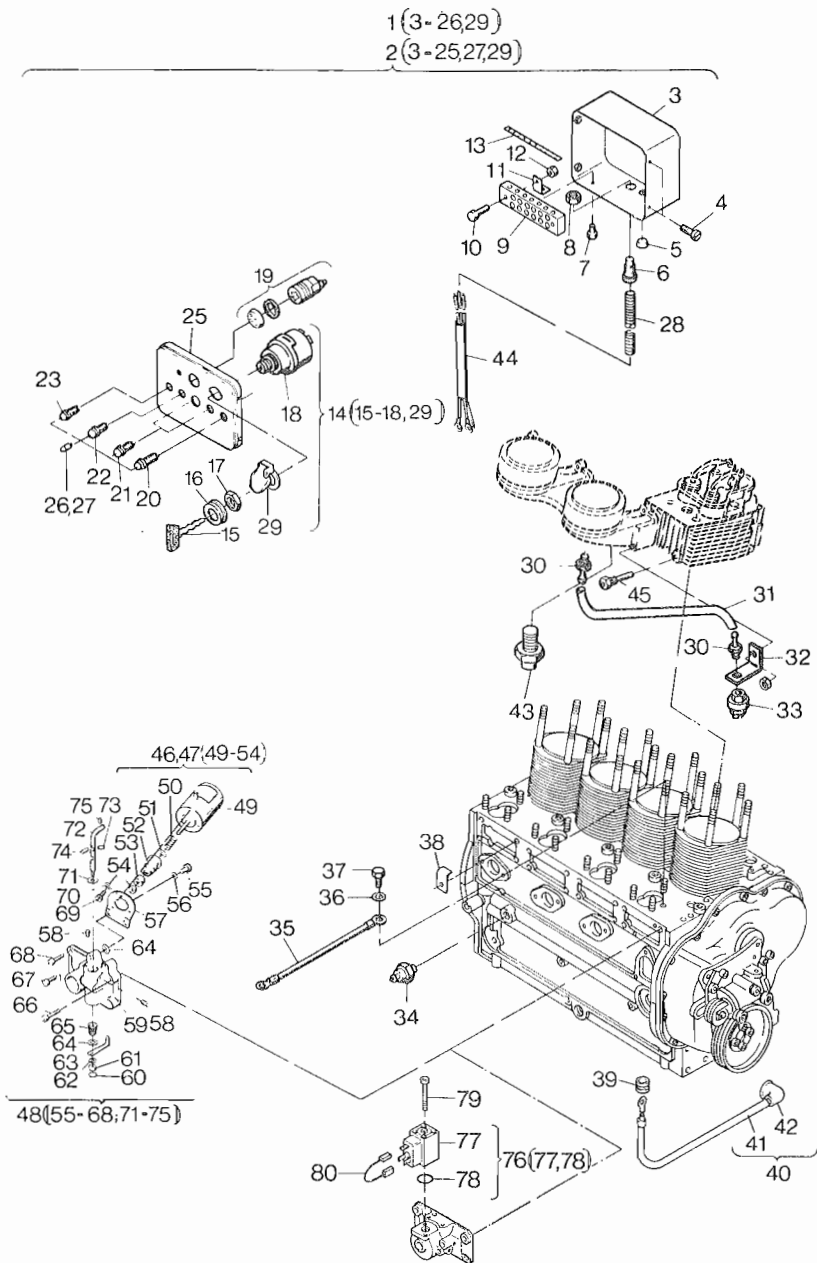

	Bestell-Nr. Ordering No. No. référence No. de pedido	Stück Quantity Quantités Cantidades		Hinweis Hints Indicaciones Indicaciones	
		4 L 30	4 L 40 4 M 40		
1	008 189 02	1	1	12 V	
2	008 305 02	1	1	24 V	
3	007 163 10	1	1		
4	501 383 00	4	4	M 6 x 10	DIN 7985-8.8 Zn
5	501 608 00	1	1		
6	501 590 10	1	1		
7	500 493 00	2	2	M 5 x 10	DIN 7985-4.8
8	501 591 00	1	1		
9	501 607 00	1	1		
10	501 588 00	2	2	M 4 x 20	DIN 84-4.8 A3C
11	036 667 00	2	2		
12	501 471 00	2	2	M 4	DIN 934-8 A3C
13	036 717 01	1	1		
14	502 765 00	1	1		
15	501 664 00 P1	1	1		
16	—	—	—		
17	—	—	—		
18	—	—	—		
19	400 686 00	1	1		
20	501 765 00	1	1	BATT	
21	501 766 00	1	1	OIL	
22	501 764 00	1	1	TEMP	
23	501 824 00	1	1	FILTER	
24	—	—	—		
25	035 092 11	1	1		
26	400 097 00	4	4	12 V 2 W	
27	400 098 00	4	4	24 V 2 W	
28	036 682 01	1	1	2000 mm	
29	490 509 00	1	1		
30	501 677 00	2	2		
31	036 937 00	1	1		
32	036 936 00	1	1		
33	501 676 00	1	1		
34	502 722 00	—	1	4 L 40 C/K	OIL
34	400 213 00	1	1	OIL	
35	008 171 00	1	1		

Tafel Nr.
Table No.
Tableau No.
Tabla No.

27

Armaturen
Electric equipment
Équipement électrique
Equipo eléctrico

1(3-26,29)

2(3-25,27,29)

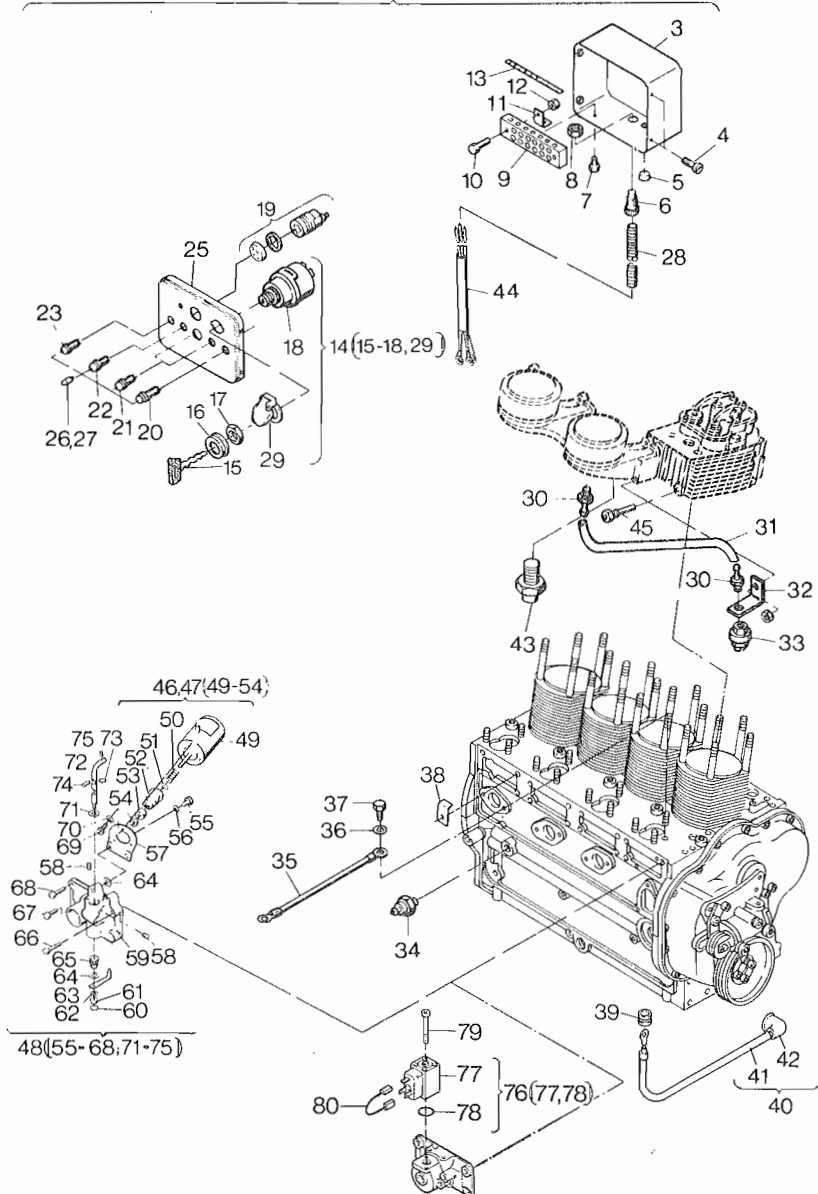

	Bestell-Nr. Ordering No. No. référence No. de pedido	Stück Quantity Quantités Cantidades			Hinweis Hints Indications Indicaciones
			4 L 30	4 L 40 4 M 40	
36	500 167 00	1	1		
37	500 267 00	1	1	M 8 x 16	DIN 933-8.8
38	036 666 00	1	2		
39	501 585 00	1	1		
40	008 203 00	1	1		
41	—	—	—		
42	400 266 00	1	1		
43	501 639 00	2	2		
44	008 202 01	1	1		
45	502 686 00	1	1	TEMP	
46	008 767 01	1	—	12 V	
47	008 768 01	1	—	24 V	
48	010 075 00	1	—		
49	—	—	—		
50	036 836 00	1	—		
51	500 166 00	1	—	6,4	DIN 125-St
52	501 804 00	1	—		
53	036 710 10	1	—		
54	500 227 00	1	—	M 6	DIN 934-8
55	500 519 00	2	—	M 8 x 20	DIN 912-8.8
56	500 028 00	2	—	8	DIN 128
57	036 707 10	1	—		
58	500 039 00	4	—	M 6 x 5	DIN 551-5.8
59	—	—	—		
60	500 430 00	1	—	16	DIN 443
61	400 282 00	1	—	M 5	SN 14440
62	500 165 00	1	—	5,3	DIN 125-St
63	036 702 00	1	—		
64	031 332 00	3	—		
65	031 744 02	1	—		
66	500 522 00	2	—	M 8 x 30	DIN 912-8.8
67	502 579 00	1	—	8 x 16	DIN 6912-8.8
68	400 808 00	1	—	M 8 x 20	DIN 912-8.8
69	500 492 00	3	—	M 4 x 10	DIN 84-4.8 A3C
70	500 164 00	3	—	4,3	DIN 125 St
71	032 131 00	1	—		

Tafel Nr.
 Table No.
 Tableau No.
 Tabla No.

27

Armaturen
 Electric equipment
 Equipement électrique
 Equipo eléctrico

1(3-26,29)
 2(3-25,27,29)

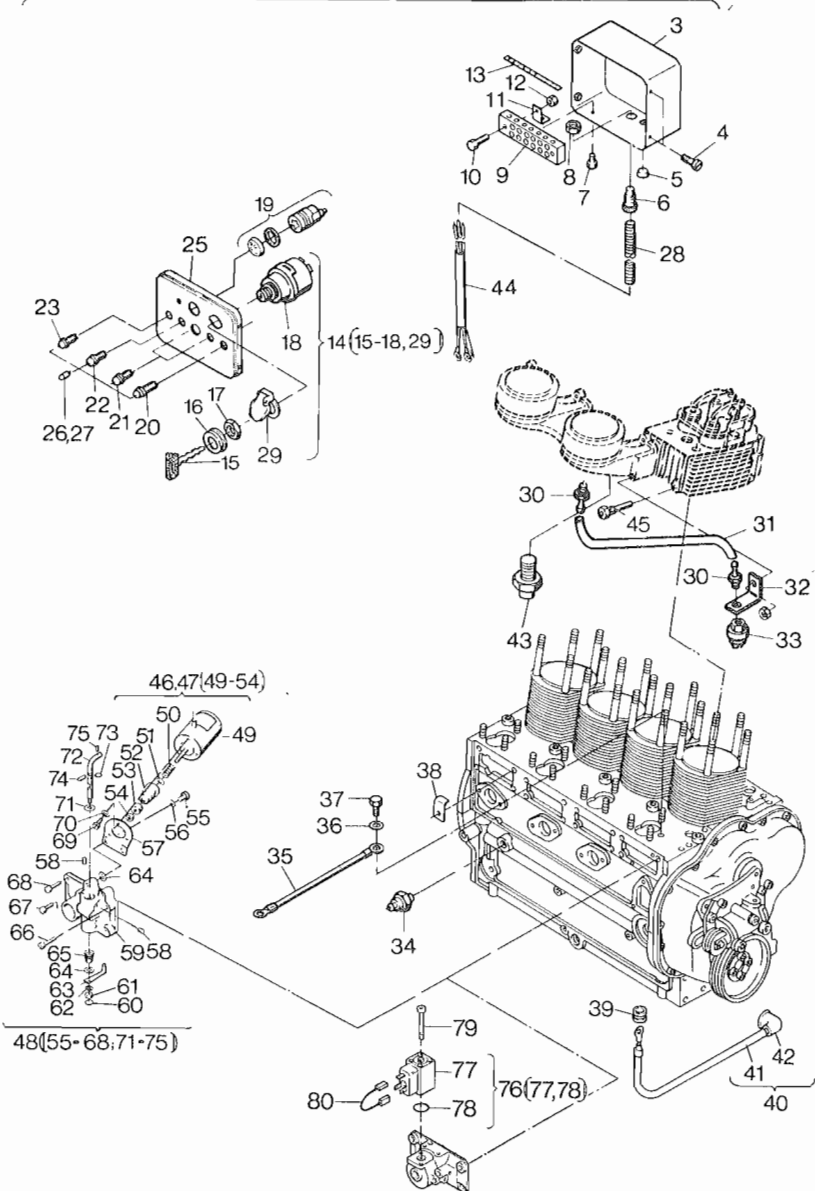

	Bestell-Nr. Ordering No. No. référence No. de pedido	Stück Quantity Quantités Cantidades		Hinweis Hints Indicaciones Indicaciones	
		4 L 30	4 L 40 4 M 40		
72	036 701 10	1	—		
73	400 217 00	1	—		
74	501 255 00	1	—	3 x 12	DIN 1481
75	501 341 00	1	—	3 x 16	DIN 1481
76	038 668 00	—	1	12 V	
76	038 669 00	—	1	24 V	
77	—	—	—		
78	502 750 00	—	1		
79	502 699 00	—	2	M 4 x 35	DIN 912-8.8 A3C
80	—	—	—		

Tafel Nr.
Table No.
Tableau No.
Tabla No.

28

Motorfüße, Anschlußgehäuse, Keilriemenschutz S
Enginebrackets, intermediate housing, v-belt guard
Pieds, moteur, bride raccord, protecteur courroie
Soportes del motor, caja de conexión, revestimiento

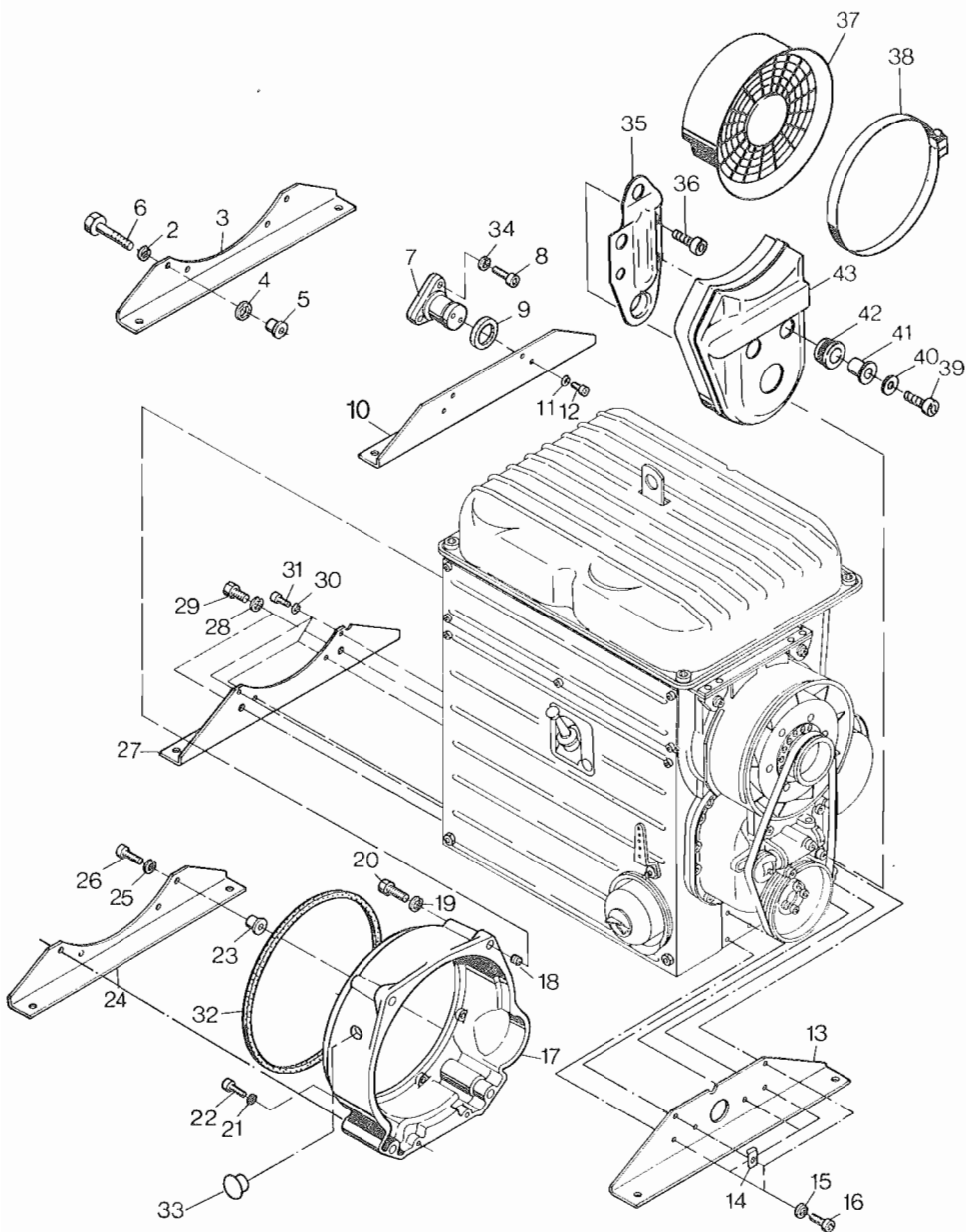

	Bestell-Nr. Ordering No. No. référence No. de pedido	Stück Quantity Cantidades Quantites		Hinweise Hints Indications Indicaciones	
		4 L 30 S/Z 4 L 40 S/Z 4 M 40	4 L 30 C/K 4 L 40 C/K		
1	—	—	—		
2	500 030 00	—	4	12	DIN 128
3	038 787 00	—	1		
4	035 798 00	—	4		
5	035 791 00	—	4		
6	502 593 00	—	4	M 12 x 110	DIN 931-8.8 A3C
7	007 393 01	—	2		
8	500 730 00	—	4	M 12 x 40	DIN 912-12.9
9	035 799 00	—	2		
10	038 789 00	—	1		
11	501 356 00	—	4	10	DIN 128 A3C
12	501 365 00	—	4	M 10 x 20	DIN 931-8.8 A3C
13	038 786 00	1	—		
14	036 696 00	1	—		
15	500 030 00	6	—	12	DIN 128
16	500 311 00	6	—	M 12 x 28	DIN 933-8.8
17	035 759 02	1	1	SAE 5	
18	501 374 00	4	4	18 x 18	DIN 7346
19	500 031 00	4	4	14	DIN 128
20	501 373 00	4	4	M 14x1,5x50	DIN 960-8.8
21	500 029 00	2	2	10	DIN 128
22	500 296 00	2	2	M 10 x 45	DIN 933-8.8
23	035 791 00	4	—		
24	038 787 00	1	—		
25	500 030 00	4	—	12	DIN 128
26	502 593 00	4	—	M 12 x 110	DIN 931-8.8 A3C
27	038 788 00	1	—		
28	500 031 00	2	—	14	DIN 128
29	501 875 00	2	—	M 14x1,5x30	DIN 961-8.8
30	500 029 00	4	—	10	DIN 128
31	500 292 00	4	—	M 10 x 25	DIN 933-8.8
32	035 929 01	—	1		
33	502 376 00	1	1		
34	034 693 00	—	4		
35	036 840 00	1	—		
36	500 530 00	3	—	M 8 x 70	DIN 912-8.8

Tafel Nr.
Table No.
Tableau No.
Tabla No.

28

Motorfüße, Anschlußgehäuse, Keilriemenschutz S
Enginebrackets, intermediate housing, v-belt guard
Pieds, moteur, bride raccord, protecteur courroie
Soportes del motor, caja de conexión, revestimiento

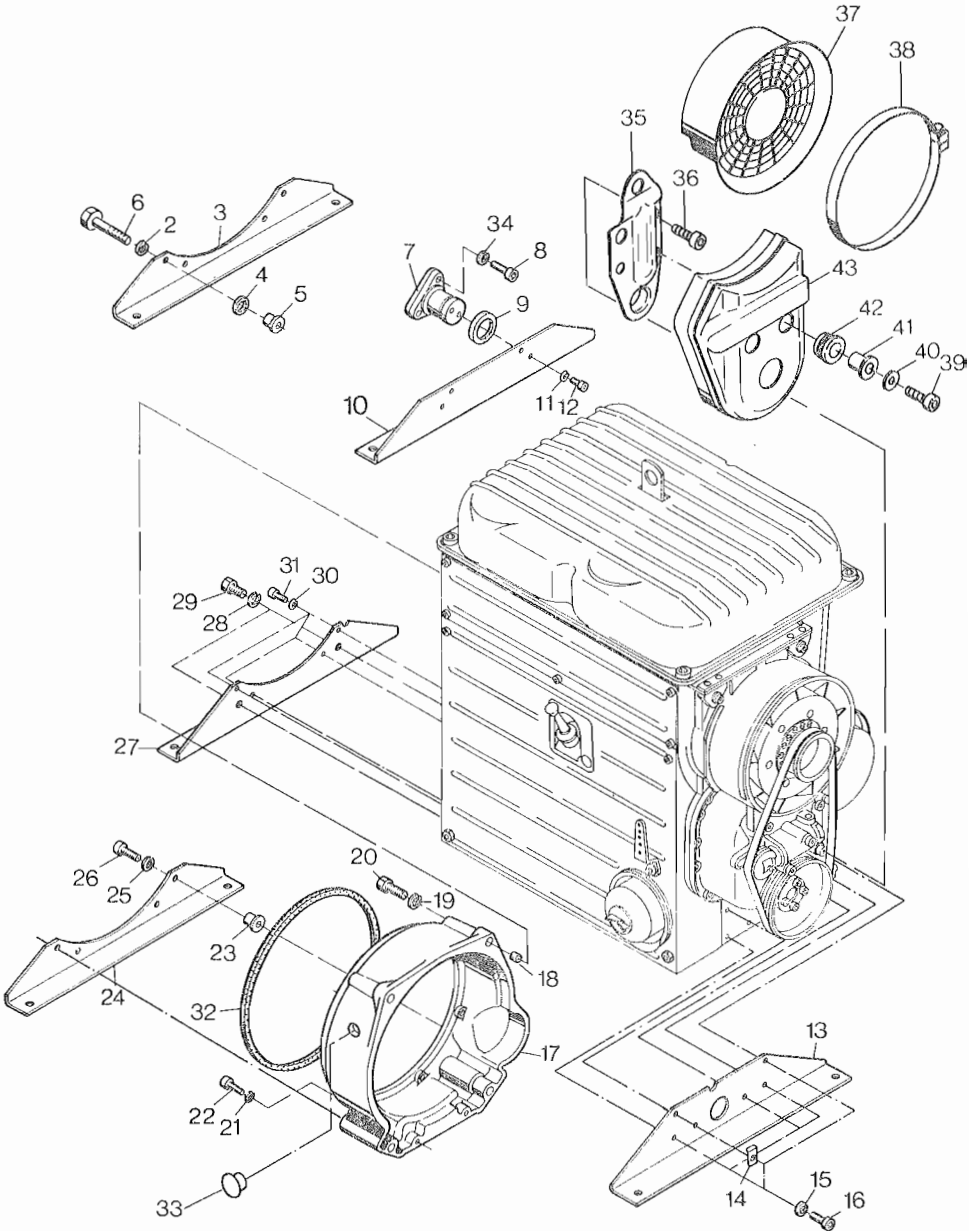

28Bestell-Nr.
Ordering No.
No. référence
No. de pedidoStück
Quantity
Quantites
CantidadesHinweis
Hints
Indications
Indicaciones

		4 L 30 S/Z 4 L 40 S/Z 4 M 40	4 L 30 C/K 4 L 40 C/K		
37	036 839 00	1	—		
38	038 024 00	1	—		
39	501 706 00	2	—	M 6 x 20	DIN 912-8.8 A3C
40	501 143 00	2	—	6,4	DIN 7349 Zn
41	033 776 00	2	—		
42	036 652 00	2	—		
43	037 110 00	1	—		

Tafel Nr.
Table No.
Tableau No.
Tabla No.

29

Ölkühler
Oil cooler
Refroidisseur huile
Radiador de aceite

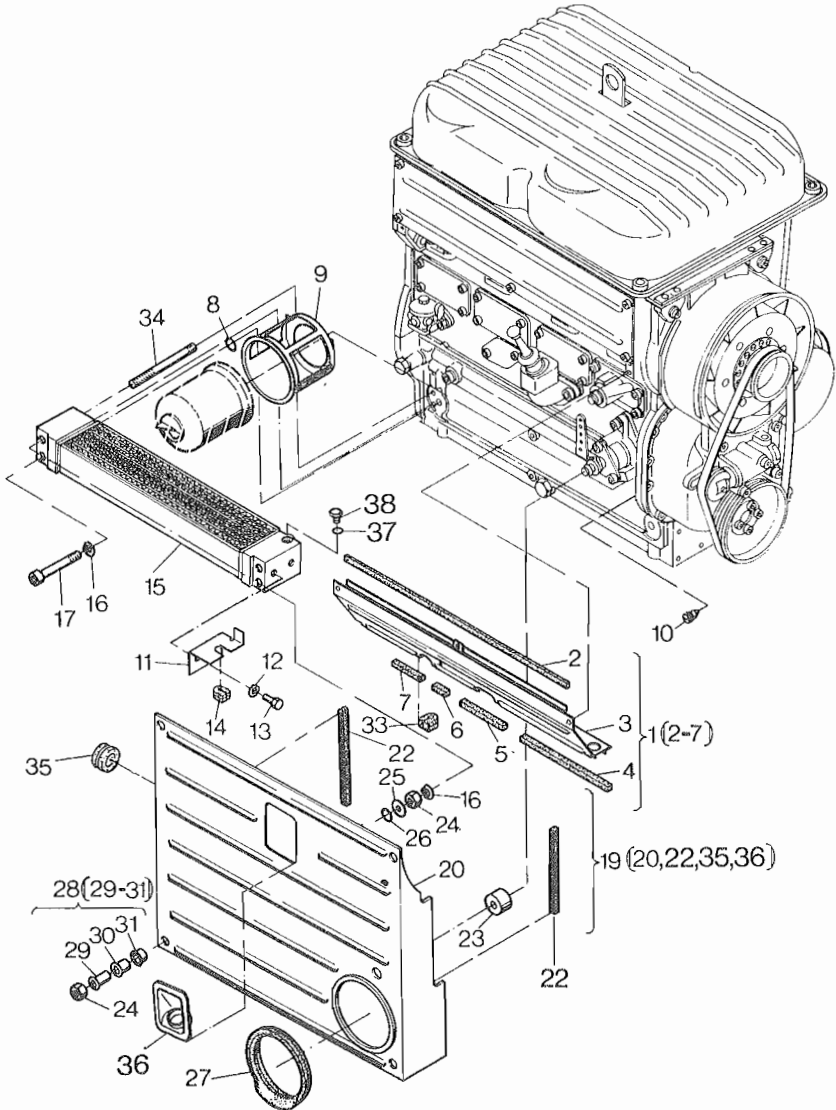

	Bestell-Nr. Ordering No. No. référence No. de pedido	Stück Quantity Quantités Cantidades					Hinweise Hints Indications Indicaciones
			4 L30 S/Z	4 L40 S/Z 4 M 40	4 L30 C/K	4 L40 C/K	
1	007 477 10	1	—	—	—		
1	007 477 11	—	1	—	—		
1	008 159 10	1	—	—	—	(f. Taf./Tab. 27, Pos. 46-75)	
1	010 810 00	—	1	—	—	(f. Taf. / Tab.27, Pos. 76)	
2	035 726 00	1	1	—	—		
3	—	—	—	—	—		
4	035 637 01	1	1	—	—	215 mm	
5	035 725 01	1	1	—	—	97 mm	
6	035 990 00	1	1	—	—	30 mm	
7	035 638 00	1	1	—	—	67 mm	
8	501 304 00	2	2	2	2		
9	009 243 00	1	1	—	—		
10	034 657 00	1	1	1	1		
11	036 201 01	—	—	1	1		
12	500 812 00	—	—	2	2	A 6 DIN 137	
13	500 255 00	—	—	2	2	M 6 x 12 DIN 933-8.8	
14	035 689 00	—	—	1	1		
15	036 480 01	1	1	1	—		
15	037 615 01	—	—	—	1		
16	500 035 00	4	4	4	4		
17	502 041 00	2	2	4	4		
18	035 797 00	1	1	—	—		
19	007 460 10	1	1	—	—		
19	008 154 10	1	—	—	—	(f. Taf./Tab. 27, Pos. 46-75)	
20	—	—	—	—	—		
21	—	—	—	—	—		
22	035 662 00	2	2	—	—	168 mm	
23	035 794 00	1	1	—	—		
24	500 229 00	4	4	—	—	M 8 DIN 934-8	
25	035 956 00	2	2	—	—		
26	035 755 00	2	2	—	—		
27	035 940 01	1	1	—	—		
28	009 214 00	2	2	—	—		
29	—	—	—	—	—		
30	—	—	—	—	—		
31	—	—	—	—	—		

Tafel Nr.
Table No.
Tableau No.
Tabla No.

29

Ölkühler
Oil cooler
Refroidisseur huile
Radiador de aceite

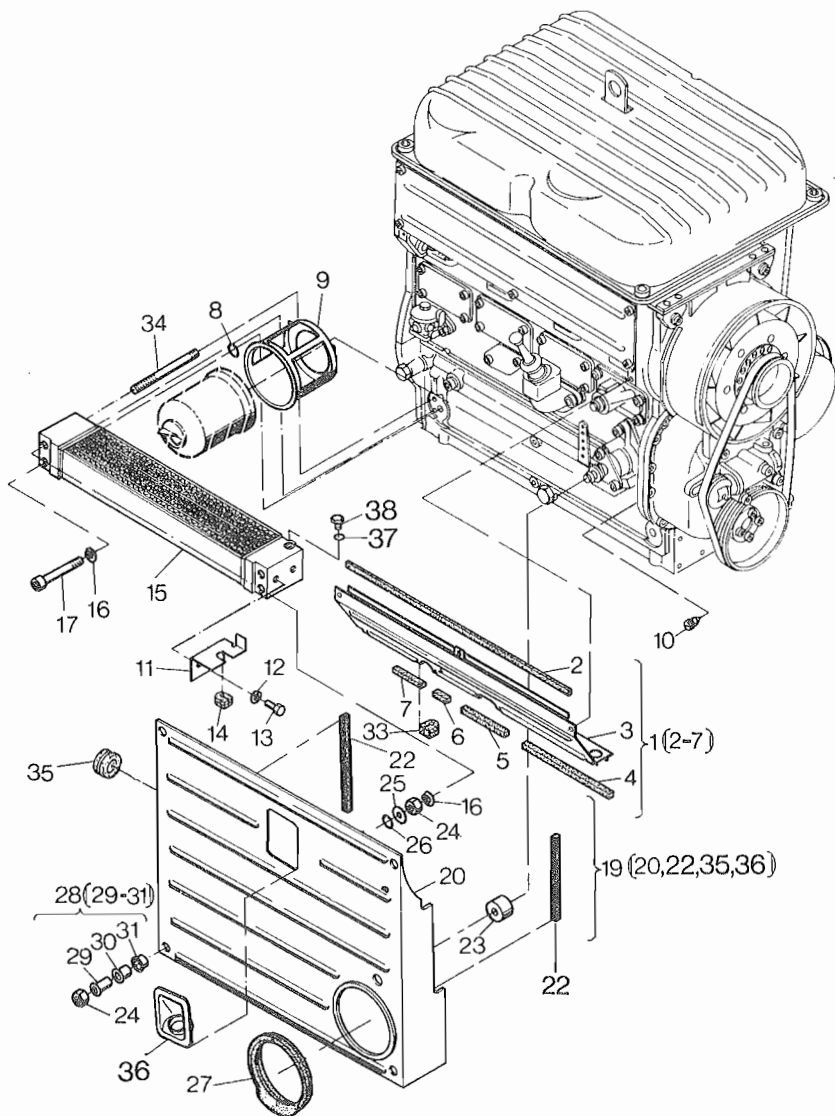

29

	Bestell-Nr.	Stück				Hinweise	
	Ordering No.	Quantity				Hints	
	No. référence	Quantities				Indications	
	No. de pedido	Cantidades				Indicaciones	
		4 L30 S/Z	4L40 S/Z 4 M 40	4L30 C/K	4 L40 C/K		
32	—	—	—	—	—		
33	035 689 00	1	1	—	—		
34	035 814 01	2	2	—	—		
35	501 587 00	1	1	—	—		
36	037 614 00	1	1	—	—		
37	500 009 00	1	—	1	—	A 8 x 11,5	DIN 7603-Cu
38	501 397 00	1	—	1	—	M 8 x 1	DIN 7604

Tafel Nr.
Table No.
Tableau No.
Tabla No.

30

Steuerdeckel für Hydraulik
Timing cover hydr.
Tige de culbuteur hydr.
Varilla de balancin hidraulico

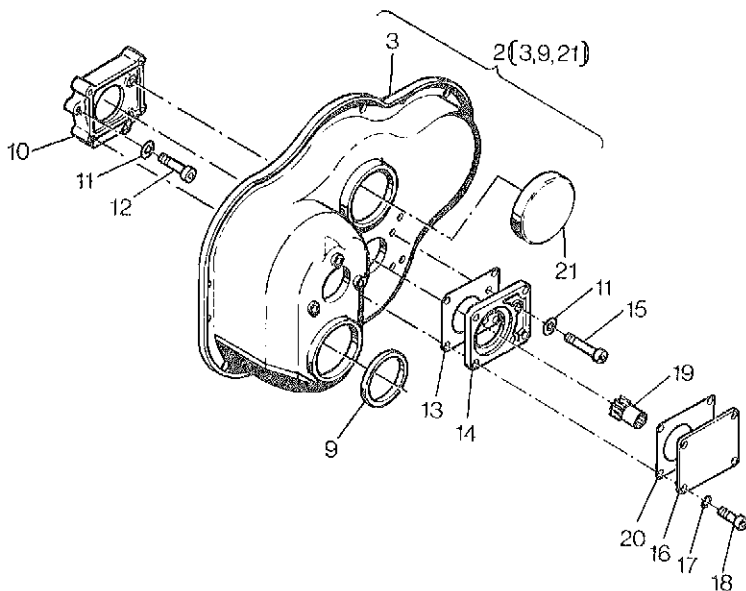

30

	Bestell-Nr. Ordering No. No. de pedido No. référence	Stück Quantity Quantites Cantidades	Hinweise Hints Indications Indicaciones	
		4 L 30, 4 L 40, 4 M 40		
1	—	—		
2	009 935 00	1		
3	—	—		
4	—	—		
5	—	—		
6	—	—		
7	—	—		
8	—	—		
9	501 291 00	1		
10	037 543 00	1		
11	501 282 00	4	8	DIN 127
12	500 525 00	2	M 8 x 40	DIN 912-8.8
13	037 544 00	1		
14	035 550 11	1		
15	502 581 00	2	M 8 x 60	DIN 6912-8.8
16	037 616 00	1		
17	501 629 00	4	A 8 x 14	DIN 7603-Cu
18	502 688 00	4	M 8 x 30	DIN 912-8.8
19	035 684 00	1		
20	035 680 00	1		
21	501 265 00	1	70	DIN 442
22	400 223 00	2	8 x 12 x 2	
23	502 620 00	2	10 x 10	DIN 7346

Änderungsübersicht
Modification table
Aperçu de modifications
Table de modificaciones

Bildtafel Table Planche Tabla	Pos. Nr. Fig. No. Fig. No. Fig. No.	Bestell-Nr. Ordering No. No. référence No. de pedido	Stück Qty. Qté. Cant. C/K		Bildtafel Table Planche Tabla	Pos. Nr. Fig. No. Fig. No. Fig. No.	Bestell-Nr. Ordering No. No. référence No. de pedido	Stück Qty. Qté. Cant. C/K	IMT NO.
4 L 30.18					4 L 30.19				85,444
11	02	009 651 00	1	≠	11	10	009 932 00	1	
30	01	009 476 10	1	≠	30	02	009 935 00	1	
15	18	036 233 00	1	≠	15	28	036 489 00	1	
11	21	036 230 00	1	≠	11	21	009 028 00	1	
11	22	036 310 00	1	≠	11	21	009 028 00	1	
11	04	036 228 01	1	—	—	—	—	—	
03	12	036 229 00	1	—	—	—	—	—	
03	14	500 251 00	4	—	—	—	—	—	
03	13	500 026 00	4	—	—	—	—	—	
15	09	035 621 03	2	≠	15	09	035 621 04	2	
15	17	036 232 00	1	—	—	—	—	—	
15	16	036 234 00	1	—	—	—	—	—	
15	21	500 442 00	1	—	—	—	—	—	
15	20	500 014 00	1	—	—	—	—	—	
—	—	—	—	—	15	14	037 567 00	1	
15	03	009 047 00	2	≠	15	03	009 047 10	2	
15	07	035 978 00	2	—	—	—	—	—	
15	02	500 167 00	2	—	—	—	—	—	
15	07	501 294 00	2	—	—	—	—	—	
15	01	501 295 00	2	—	—	—	—	—	
—	—	—	—	—	15	08	037 523 01	2	
29	19	007 460 03	1	≠	29	19	007 460 10	1	
29	19	008 154 01	1	≠	29	19	008 154 10	1	
17	11	007 462 02	1	≠	17	11	007 462 10	1	
17	11	008 067 00	1	≠	17	11	008 067 10	1	
29	01	007 477 02	1	≠	29	01	007 477 10	1	
29	01	008 159 00	1	≠	29	01	008 159 10	1	

Änderungsübersicht
Modification table
Aperçu de modifications
Table de modificaciones

Bildtafel	Pos. Nr.	Bestell-Nr.	Stück		Bildtafel	Pos. Nr.	Bestell-Nr.	Stück	IMT NO.
Table	Fig. No.	Ordering No.	Qty.		Table	Fig. No.	Ordering No.	Qty.	
Planche	Fig. No.	No. référence	Qté.		Planche	Fig. No.	No. référence	Qté.	
Tabla	Fig. No.	No. de pedido	Cant.		Tabla	Fig. No.	No. de pedido	Cant.	
			S/Z/C/K					S/Z/C/K	

4 L 40.14

4 L 40.15

85.443

07	15	034 688 00	1	≠	07	15	034 688 10	1	
07	28	034 689 10	1	≠	07	28	034 689 20	1	
07	09	500 195 00	1	≠	07	09	500 350 00	1	
07	11	031 694 00	1	—	—	—	—	—	
07	12	031 696 00	1	—	—	—	—	—	
07	13	031 697 00	1	—	—	—	—	—	
07	14	031 698 00	1	—	—	—	—	—	
07	10	501 321 00	1	—	—	—	—	—	
07	25	502 243 00	1	—	—	—	—	—	
07	26	502 244 00	1	—	—	—	—	—	

Änderungsübersicht
Modification table
Aperçu de modifications
Tabla de modificaciones

Bildtafel	Pos. No.	Bestell-Nr.	Stück	Bildtafel	Pos. No.	Bestell-Nr.	Stück	IMT NO.
Table	Fig. No.	Ordering No.	Qty.	Table	Fig. No.	Ordering No.	Qty.	
Planche	Fig. No.	No. référence	Qté.	Planche	Fig. No.	No. référence	Qté.	
Tabla	Fig. No.	No. de pedido	Cant.	Tabla	Fig. No.	No. de pedido	Cant.	
			S/Z/C				S/Z/C	

4 M 40.11

4 M 40.12

85.443

07	15	034 688 00	1	≠	07	15	034 688 10	1
07	28	034 689 10	1	≠	07	28	034 689 20	1
07	09	500 195 00	1	≠	07	09	500 350 00	1
07	11	031 694 00	1	—	—	—	—	—
07	12	031 696 00	1	—	—	—	—	—
07	13	031 697 00	1	—	—	—	—	—
07	14	031 698 00	1	—	—	—	—	—
07	10	501 321 00	1	—	—	—	—	—
07	25	502 243 00	1	—	—	—	—	—
07	26	502 244 00	1	—	—	—	—	—

