

**HATZ**  
DIESEL

Motorenfabrik HATZ GmbH & Co KG  
D-8399 Ruhstorf a. d. Rott  
Tel.: 08531/319-1, Telex: 57260, Telefax: 08531/32716

Druck: Krönner, 34/351.2 - 3.89 - 7.5  
Printed in West-Germany

Schutzgebühr DM 3.—  
Protection tax  
Taxe de protection  
Derecho de protección

Ersatzteil-Liste  
Spare parts list  
Liste des pièces de rechange  
Lista de recambios

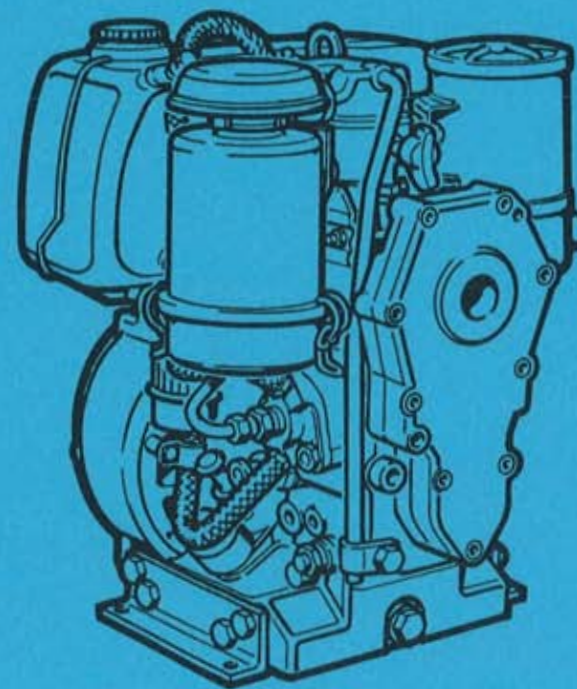

**HATZ**  
DIESEL

**E 573...**  
**E 673...**

No. E 573.11  
No. E 673.11

WICHTIG — Bitte Daten eintragen  
IMPORTANT — Compléter les données

IMPORTANT — Please enter data  
IMPORTANTE — Favor completar datos

1.

Bitte hier **Type, Motornummer** und **Drehzahl** (siehe Motor-Typenschild) eintragen.

Enter here **type engine no.** and **rpm.** (see engine type-plate).

Indiquer ici le **type, N° de moteur** et **régime** (voir plaque signalétique).

Insertar aquí **tipo- N° motor** y **r.p.m.** (vea placa del motor).

MOTORENFABRIK HATZ <sup>GmbH &amp; Co. KG</sup>			
D-8399 RUHSTORF/ROTT			
TYP	KENNZ.		
<input type="text"/>	<input type="text"/>		
MOTOR/FABRIK NO.		ABE/AUSF.	
<input type="text"/>	<input type="text"/>		
MINI	NH	PV	GM°
<input type="text"/>	<input type="text"/>	<input type="text"/>	<input type="text"/>
<b>HATZ</b>			
<b>DIESEL</b>			
MADE IN GERMANY (FED. REP.)			

1

2.

Bitte **Ersatzteillistennummer** (siehe Titelseite) gemäß Type ankreuzen, z. B. Typ E 573:

E 573.11

Mark **spare parts list no.** (see title-page) acc. to type, e. g. for type E 573:

E 573.11

Cocher le **N° de liste de pièces de rechange** (voir: couverture) selon type, par. ex. E 573:

E 573.11

Marcar **N° lista de recambios** (ver: frontispició) de acuerdo aipo, ejemplo tipo E 573:

E 573.11

Ersatzteilliste Nr.  
Spare parts list no.  
Liste des pièces de rechange no.  
Lista de recambios no.

E 573.11     E 673.11

2

3.

Bitte tragen Sie hier die **Anschrift** Ihrer nächsten HATZ-Servicestelle ein.

Insert here **address** of your next HATZ Service station.

Indiquer ici l'**adresse** de votre stationservice HATZ la plus proche.

Insertar aquí **dirección** de servicio HATZ más cercano.

HATZ-Service

3

MOTORENFABRIK HATZ  
GmbH & Co. KG  
D-8399 RUHSTORF a. d. ROTT  
Federal Republic of Germany  
☎ (08531) 319-1 · ☎ 57260

### Angaben bei Ersatzteilbestellungen:

Zur richtigen und schnellen Belieferung mit Ersatzteilen sind folgende Angaben erforderlich:

1. **Type, Motornummer und Drehzahl** des Motors, für den das Ersatzteil benötigt wird: siehe Angaben auf Seite 1, Feld 1.
2. **Nummer der Ersatzteilliste**, aus der die Bestellnummer herausgelesen wurde: siehe Seite 1, Feld 2.
3. **Stückzahl und Bestell-Nr.** des gewünschten Ersatzteils.
4. Gewünschte **Versandart**, z. B. Post, Luftfracht, Express.
5. Genaue **Versandadresse**, wenn erforderlich mit Post- u. Bahnstation.

### Bestellbeispiel:

Für Motortype: E 673 LK  
Motornummer: 561189054622  
min<sup>-1</sup>: 3000/60  
aus Ersatzteilliste E 673.11

folgende Teile:

Stück	Bestell-Nr.
2	500 246 00
6	032 062 00

per Postexpress an ...

### Die Ersatzteilbestellung richten Sie bitte an:

— die nächste HATZ-Servicestelle, Anschrift siehe Seite 1, Feld 3 oder separates Servicestellenverzeichnis

— oder an die

Motorenfabrik Hatz GmbH & Co. KG  
D - 8399 Ruhstorf a. d. Rott  
Federal Republic of Germany  
☎ (08531) 319-1 · ☎ 57260

### Particulars for spare parts orders:

The following information is needed to ensure correct and prompt supply of spare parts:

1. **Engine type, engine number and r.p.m.** of the engine for which you need the spare part.  
See particulars on page 1, field 1.
2. **Number of spare parts list** from which you took the ordering no., see page 1, field 2.
3. **Quantity and ordering no.** of requested spare part.
4. Requested **mode of dispatch**, e. g. surface/airmail, airfreight, express.
5. Exact **shipping address**, if necessary indicate local post office and/or railway station.

### Example for your order:

For engine type: E 673 LK  
Engine number: 561189054622  
R. p. m.: 3000/60  
Spare parts list no. E 673.11

The following parts:

Qty.	ordering-no:
2	500 246 00
6	032 062 00

to be mailed, express, to ...

### Please address your spare parts order to:

— your nearest Hatz service station, address see page 1, field 3 or separate Hatz-service-List

— or to

Motorenfabrik Hatz GmbH & Co. KG  
D - 8399 Ruhstorf a. d. Rott  
Federal Republic of Germany  
☎ (08531) 319-1 · ☎ 57260

### Données à indiquer lors de vos commandes de pièces détachées:

Pour nous permettre de livrer vos pièces rapidement et correctement, nous avons besoin des données suivantes:

1. **Type, No. et régime du moteur** pour lequel vous avez besoin de pièces: voir données page 1, carré 1.
2. **No. de la liste de pièces de rechange** dans laquelle figure le No. de commande: voir page 1, carré 2.
3. **Quantité et No. de commande** de la pièce souhaitée.
4. **Mode d'expédition** souhaitée: par ex. par poste, frêt aérien, express.
5. **Adresse exacte de destination** et, lorsque ceci est nécessaire, le nom de la poste et de la gare, ou aéroport.

### Exemple:

Pour type de moteur: E 673 LK

No. moteur: 561189054622

Régime: 3000/60

Liste de pièces de rechange: E 673.11

Les pièces suivantes:

Qté.	No. commande
2	500 246 00
6	032 062 00

par poste express à . . .

### Les commandes de pièces détachées sont à adresser à:

— votre station-service HATZ la plus proche, voir adresse page 1, carré 3 ou liste de service séparée.

— ou

Motorenfabrik Hatz GmbH & Co. KG  
D-8399 Ruhstorf a. d. Rott  
République Fédérale d'Allemagne  
☎ (08531) 319-1 · ☎ 57260

### Datos para pedidos de recambios:

Para recibir sus recambios en forma rápida y correcta necesitamos las siguientes informaciones:

1. **Tipo, número del motor y revoluciones:**  
ver detalles en página 1, posición 1.
2. **Número de la lista de recambios** de la cual se ha obtenido el número de pedido: ver página 1, posición 2.
3. **Cantidad y número de pedido** del recambio deseado.
4. Tipo de **despacho deseado:** por ej. correo, flete aéreo, expreso etc.
5. **Dirección** exacta, si necesario indicar la oficina de correo, la estación ferroviaria o aeropuerto.

### Ejemplo de pedido:

Para motor tipo: E 673 LK

Número de motor: 561189054622

R. P. M.: 3000/60

De la lista de recambios: E 673.11

Siguientes recambios:

Cantidad	Número de pedido
2	500 246 00
6	032 062 00

Por correo expreso para . . .

### El pedido de recambios favor dirigirlo a:

— Al servicio HATZ más cercano, dirección verla en página 1, posición 3 o en el índice separado de direcciones de servicio.

— Alternativa a:

Motorenfabrik Hatz GmbH & Co. KG  
D-8399 Ruhstorf a. d. Rott  
República Federal de Alemania  
☎ (08531) 319-1 · ☎ 57260

	<b>Inhaltsverzeichnis</b>	<b>Index</b>	<b>Tafel-Nr. Table No.</b>
M . . .	Grundmotor	Basic engine	
00, 34	Ersatzteilsätze, Zubehör, Schilder	Spare part kits, accessories, labels	01
01	Kurbelgehäuse	Crankcase	02
01	Drehzahlverstellung	Speed control	03
02, 03	Kurbelwelle	Crankshaft	04
04, 11	Nockenwelle, Steuerdeckel	Camshaft, timing cover	05
05, 06	Kolben, Pleuel, Zylinder	Piston, conrod, cylinder	06
07	Zylinderkopf	Cylinder head	07
09, 14	Stoßstange, Einspritzausrüstung	Pushrod, Injection equipment	08
15, 17	Andrehvorrichtung, Schwungrad	Starting device, flywheel	09
15	Reversierstarter	Recoil starter	10
A . . .	Zusatzausrüstung	Equipements	
01	Kraftstoffbehälter	Fuel tank	11
02, 03	Luftfilter, Auspufftopf	Air, filter, exhaust silencer	12
04	Andrehkurbel, Startscheibe	Starting handle, starter pulley	13
09, 16	Drehzahlverstellung einstellbar, Wellenstummel, Zentrierflansch	Speed control, stubshaft, cent. flange flyw. side	14
			<b>Seite, Page</b>
	Zusatzausrüstungen	Equipements	41 - 43
	Serien-Nr.-Änderungen	Serial-code modification list	44

	<b>Sommaire</b>	<b>Indice</b>	
M . . .	Moteur de base	Motor de base	
00, 34	Jeu de pièces de rechange, accessoires, plaques	Juegos de recambios, accesorios, placas	01
01	Carter moteur	Caja cigueñal	02
32	Reglage régime	Ajuste de revoluciones	03
02, 03	Vilebrequin	Cigueñal	04
04, 11	Arbre à cames, couvercle distribution	Arbol de levas, tapa de mando	05
05, 06	Piston, bielle, cylindre	Emboló, biela, cilindro	06
07	Culasse	Culata	07
09, 14	Tige de culbuteur, Equipement d'injection	Varilla de balancín, Equipo de inyección	08
15, 17	Dispositif démarrage, volant	Dispositivo de arranque, volante	09
15	Demarreur reversible	Arrancador reversible	10
A . . .	Accessoires	Equipos	
01	Reservoir à carburant	Depósito combustible	11
02, 03	Filtre à air, silencieux	Filtro de aire, silenciador	12
04	Manivelle, poulie lancement	Manivela, polier de arranque	13
09, 16	Reglage regime, bout de arbre, bride centr. c. vol.	Ajuste de velocidad. eje, brida de centraje	14
			Page, Página No.
	Aperçu de modifications	Tabla de modificaciones	41 - 43
	Modification des Nos de serien	Modificación de los Nos de serie	44

M 00

Ersatzteilsätze  
Spare part kits  
Jeux de pièce de rechange  
Juegos de piezas de recambios

M 34

Zubehör  
Accessories  
Accessoires  
Accessorios

Tafel Nr.  
Tabl. No.  
01

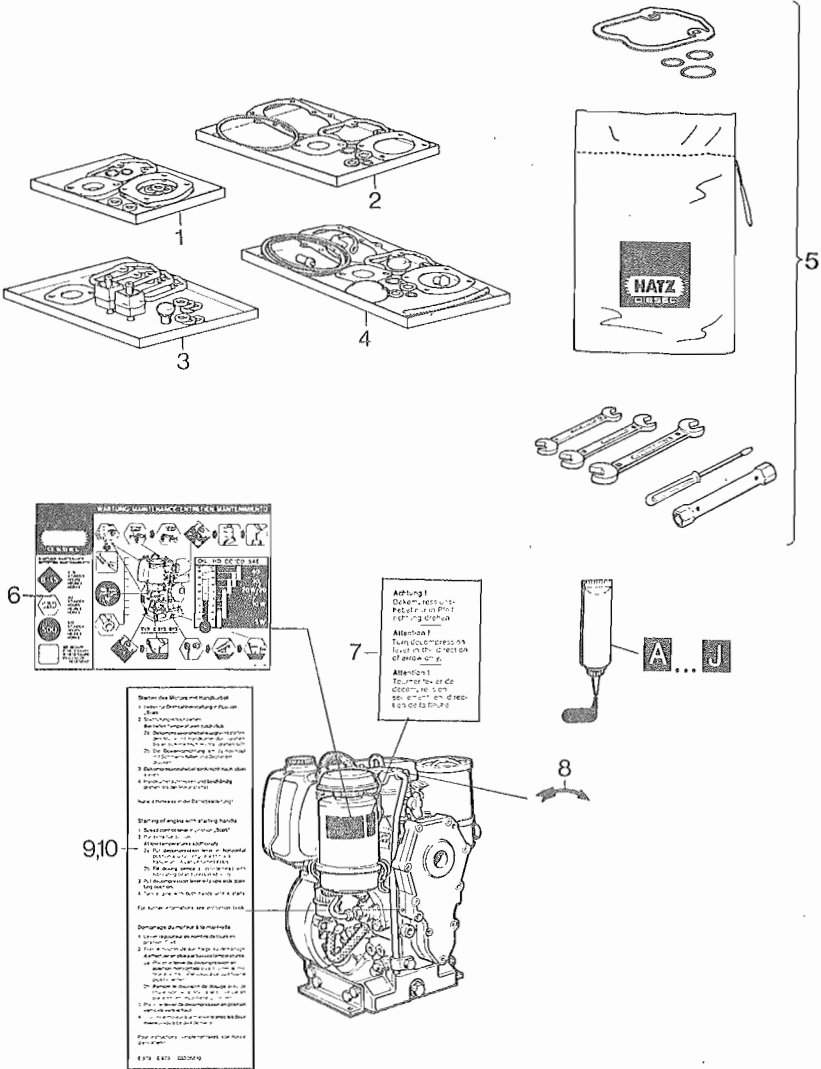

Fig. No.	Bestell-Nr. Ordering No. No. référence No de pedido	Stück Quantity Quantités Cantidades	Hinweise Hints Indications Indicaciones
----------	--	--	--

E 573 | E 673

P: Im Pannensatz enthalten. — Incl. in emergency kit. — Contenu dans le jeu secur. — Incluido en el juego para averias.  
W: Im Wartungssatz enthalten. — Incl. in maintenance kit. — Contenu dans le jeu d'entretien. — Incluido en el juego de mantenimiento.  
1: Anzahl pro Satz. — Qty. per kit. — Quantite par jeu. — Cantidad por juego.  
d: Im Dichtungssatz f. 1 Zyl.-K. enthalten. — Incl. in gasket set f. 1 cyl. head. — Contenu dans le jeu de joint p. 1 culasse. — Incluido en el juego de juntas p. 1 culata.  
D: Im Dichtungssatz Kurbelgeh. enth. — Incl. in gasket set crankcase. — Contenu dans le jeu de joints carter moteur. — Incluido en el juego de juntas caja cigueñal.

1	009 106 10 P1	1	1	Dichtungssatz für 1 Zylinderkopf Gasket set for 1 cyl. head Jeu de joint p. 1 culasse Juego de juntas para 1 culata
2	012 297 00	1	1	Dichtungssatz Kurbelgehäuse Gasket set crankcase Jeu de joints carter moteur Juego de juntas caja cigueñal
3	009 612 01	1	1	Wartungssatz für 1000 h 1000 hours maintenance kit Kit d'entretien 1000 heures Juego de piezas para 1000 horas mantenimiento
4	009 656 03	1	1	Pannensatz Emergency kit Kit de secours Juego para averias
5	004 384 00	1	1	Zubehörsatz Accessories kit Sort. accessoires Juego de accesorios
6	036 311 02	1	1	
7	033 963 01	1	1	
8	035 890 00	1	1	
9	033 255 10	1	1	
10	033 068 10	1	1	LS, RS

Dicht- und Klebstoffe Sealing- and bonding adhesives		Etanchéifiant et Colle Materias para empaquetar y pegar	
A =	502 230 00 Loctite Activator	—	165 ml
B =	502 231 00 Loctite 573	—	50 ml
C =	502 232 00 Loctite 601	—	50 ml
D =	502 233 00 Loctite 221	—	50 ml
E =	502 234 00 Loctite 648	—	10 ml
F =	502 238 00 Technicoll 8058	—	0,750 kg
+	502 239 00 Technicoll 8366	—	0,750 kg
G =	502 565 01 Loctite IS 407	—	20 ml
H =	502 825 01 Silicon	—	75 ml
J =	502 830 00 Hochtemp. Paste	—	100 g

s. Hinweis auf den einzelnen Bildtafeln  
as specified in the individual tables  
suivant les remarques sur les tableau  
correspondant  
Según las indicaciones de las tablas  
correspondientes



M 01

Kurbelgehäuse  
Crankcase  
Carter moteur  
Caja cigueñal

Tafel Nr.  
Tabl. No.

02

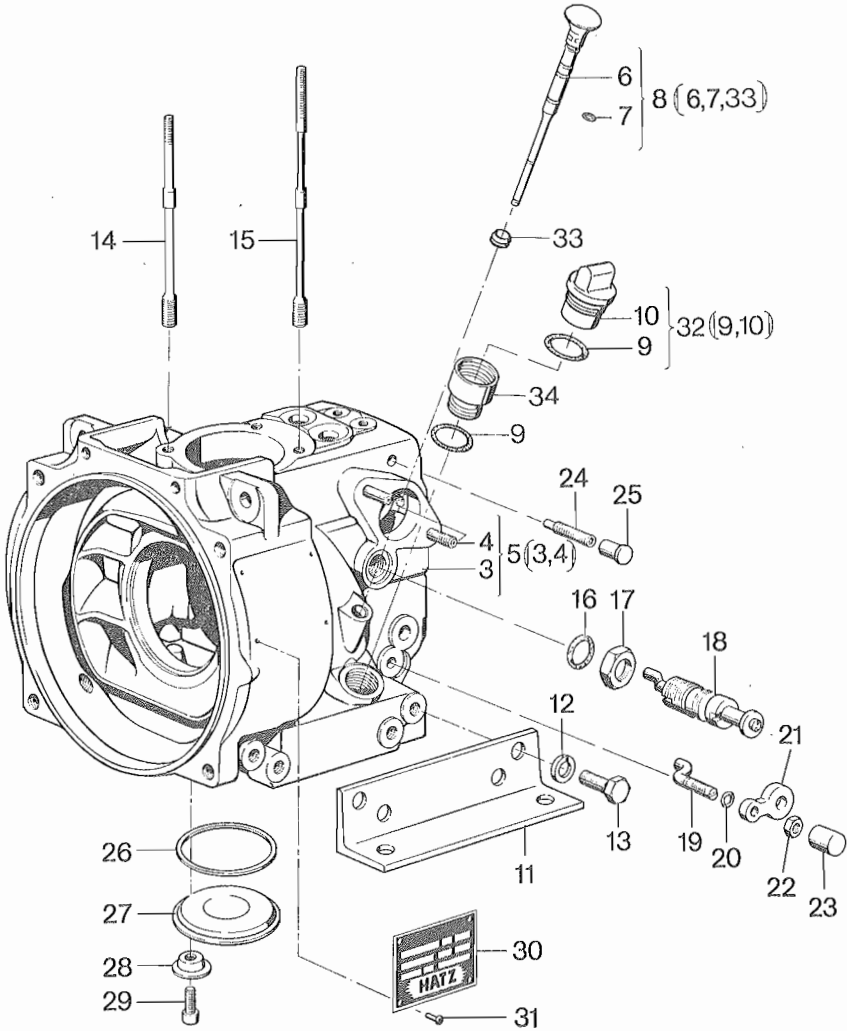

Fig. No.	Bestell-Nr.	Stück	Hinweise		
	Ordering No.	Quantity	Hints		
	No. référence	Quantites	Indications		
	No de pedido	Cantidades	Indicaciones		
		E 573	E 673		
1	--	--	--		
2	--	--	--		
3	--	--	--		
4	500 373 00	2	2	M 8 x 18	DIN 835-10.9
5	009 128 00	1	1		
6	--	--	--		
7	400 220 00 D2	2	2		
8	003 088 02	1	1		
9	501 538 00 D1	2	2		
10	--	--	--		
11	030 621 00	2	2		
12	500 029 00	8	8	10	DIN 128
13	500 292 00	8	8	M 10 x 25	DIN 933-8.8
14	032 077 01	2	2		
15	032 076 00	2	2		
16	400 228 00 D1	1	1		
17	500 246 00	1	1	M 20 x 1,5	DIN 936-5
18	003 624 00	1	1		
19	030 604 03	1	1		
20	400 217 00 D1	1	1		
21	031 049 01	1	1		
22	500 229 00	1	1	M 8	DIN 934-8
23	032 058 00	1	1		
24	500 621 00	1	1	AM 8 x 25	DIN 915-TUFLOK
25	400 397 01	1	1		
26	400 238 00 D1	1	1		
27	032 056 02	1	1		
28	032 062 00	4	4		
29	500 504 00	4	4	M 6 x 8	DIN 6912-8.8
30	032 255 03	1	1		
31	400 025 00	4	4	2,4	
32	006 321 00 W1	1	1		
33	503 244 00	1	1		
34	036 584 00	1	1		

M 01

Drehzahlverstellung  
Speed control  
Reglage régime  
Ajuste de revoluciones

Tafel Nr.  
Tabl. No.

03

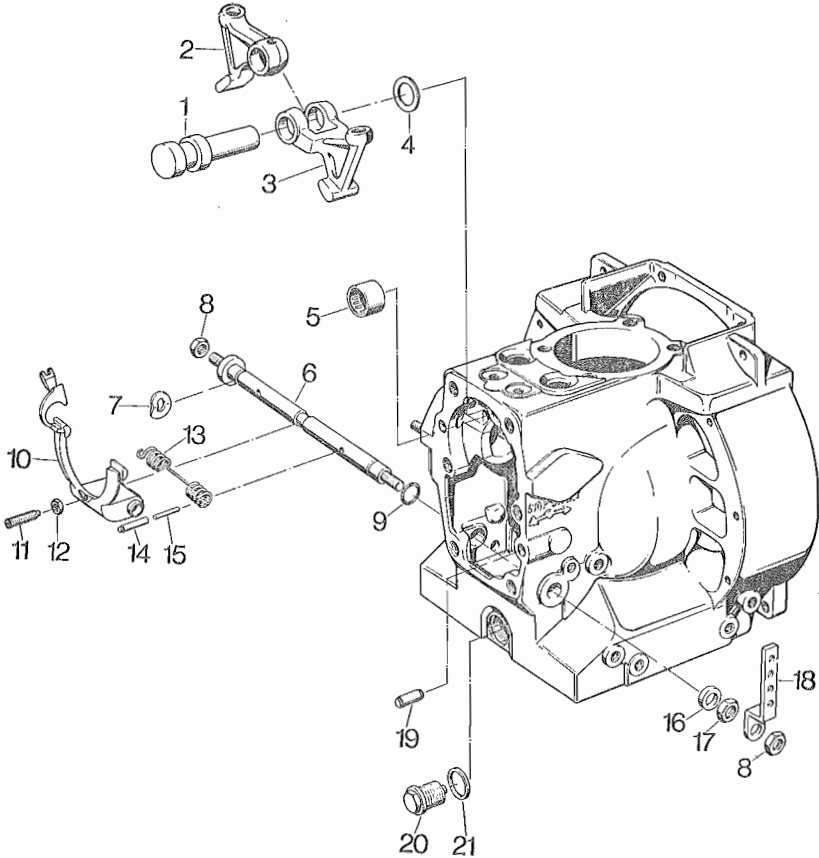

Fig. No.	Bestell-Nr. Ordering No. No. référence No de pedido	Stück Quantity Quantites Cantidades		Hinweise Hints Indications Indicaciones	
		E 573	E 673		
1	030 597 00	1	1		
2	030 634 01	1	1		
3	030 633 01	1	1		
4	031 698 00	1	1	0,50 mm	
5	400 368 00	1	1		
6	004 273 03	1	1		
7	500 036 00	1	1	B 12	DIN 137
8	500 235 00	2	2	M 10	DIN 934-8
9	400 223 00 D2	2	2		
10	003 087 04	1	1		
11	500 042 00	1	1	M 6 x 20	DIN 915-45 H
12	500 227 00	1	1	M 6	DIN 934-8
13	032 065 00	1	1	2,0 mm $\phi$	$\dots$ 1800 min <sup>-1</sup>
13	040 072 00	1	1	2,4 mm $\phi$	$>$ 1800 $\dots$ 2000 min <sup>-1</sup>
13	032 057 04	1	1	2,7 mm $\phi$	$>$ 2000 min <sup>-1</sup>
13	034 442 01	1	1	2,6 mm	3000 min <sup>-1</sup> Gen.
14	500 349 00	2	2	5 x 36	DIN 1481
15	500 343 00	2	2	3 x 36	DIN 1481
16	031 462 01	1	1		
17	032 061 00	1	1		
18	032 060 00	1	1		
19	031 693 00	2	2		
19	500 586 00	1	1	LS/RS 8 M 6x50	DIN 7-9 S20K
20	031 691 03 W1	1	1		
21	500 015 00W7, D1	1	1	A 21 x 26	DIN 7603-Cu

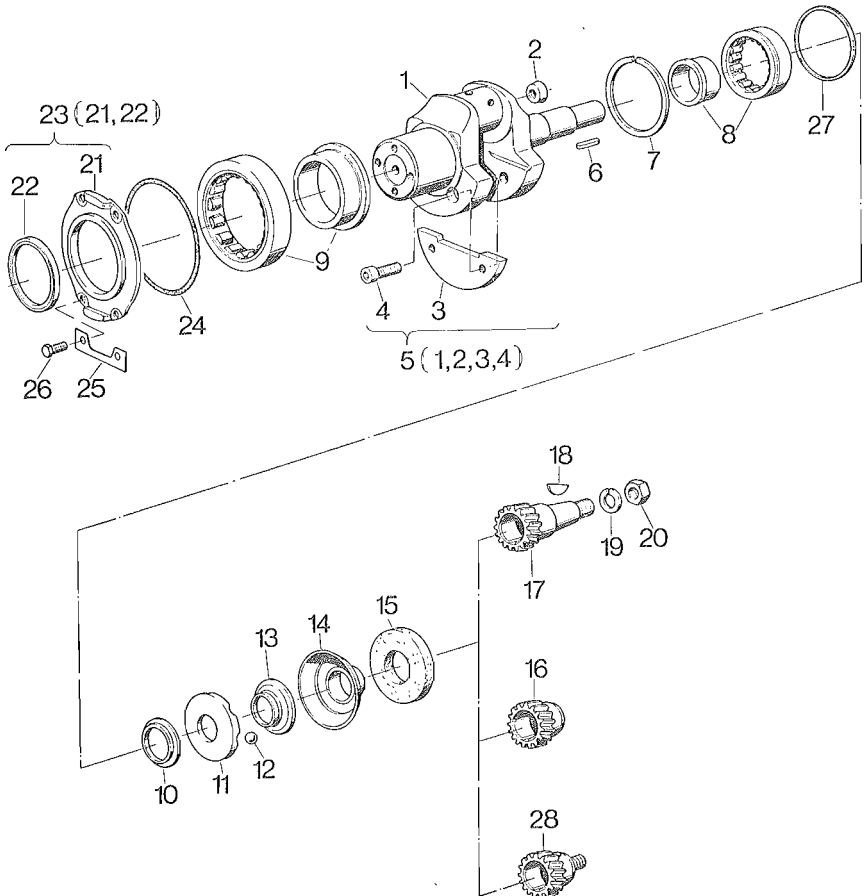

Fig. No.	Bestell-Nr. Ordering No. No. référence No de pedido	Stück Quantity Quantites Cantidades	Stück Quantity Quantites Cantidades	Hinweise Hints Indications Indicaciones	
		E 573   E 673			
1	—	—	—		
2	031 950 00	1	1		
3	030 609 01	2	2		
4	500 518 00	4	4	M 8 x 18	DIN 912-8.8
5	003 612 02	1	1		
6	500 111 00	1	1	A 6 x 4 x 28	DIN 6885
7	500 362 00	1	1	Sp 72	DIN 5417
8	500 477 00	1	1		
9	500 471 00	1	1		
10	032 066 00	1	1		
11	030 066 02	1	1		
12	500 100 00	4	4		
13	031 700 01	1	1		
14	007 420 00	1	1		
14	012 132 00	1	1	Gen.	
15	030 045 01	1	1		
16	030 648 01	1	1	LN/LNF/LS/RN/RNF/RS/LHK/RHK	
17	030 649 01	1	1	LK/LKF/RK/RKF	
18	500 179 00	1	1	6 x 7,5	DIN 6888
19	500 032 00	1	1	16	DIN 128
20	500 245 00	1	1	M 16 x 1,5	DIN 936-17 H
21	—	—	—		
22	400 342 00 D1	1	1		
23	005 630 01	1	1		
24	501 540 00 D1	1	1	110 x 3	
25	032 059 01	2	2		
26	500 255 00	4	4	M 6 x 12	DIN 933-8.8
27	033 804 00	0..1	0..1	0,10 mm	
27	033 805 00	0..1	0..1	0,20 mm	
27	038 806 00	0..1	0..1	0,30 mm	
27	038 807 00	0..1	0..1	0,40 mm	
27	033 808 00	0..1	0..1	0,50 mm	
28	039 458 00	1	1	LR	

M 04

Nockenwelle  
Camshaft  
Arbre à cames  
Arbol de levas

M 11

Steuerdeckel  
Timing cover  
Couvercle distribut  
Tapa de mando

Tafel Nr.  
Tabl. No.

05

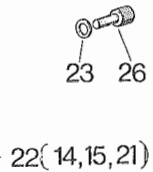
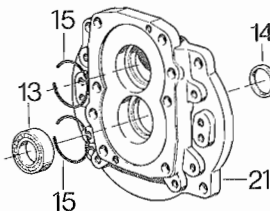
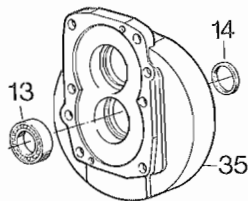
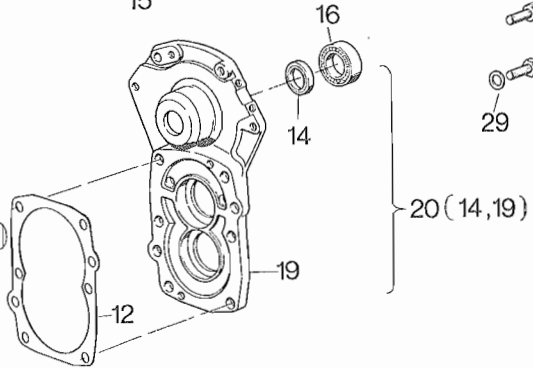
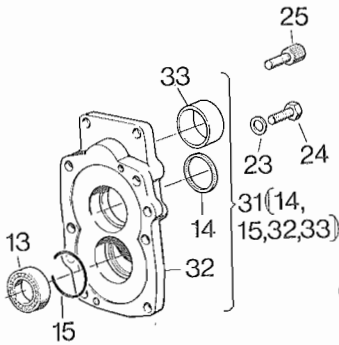
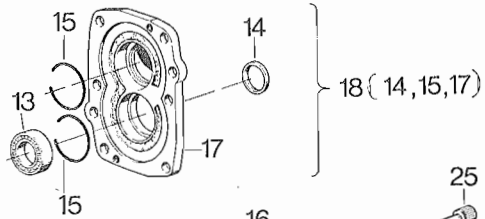
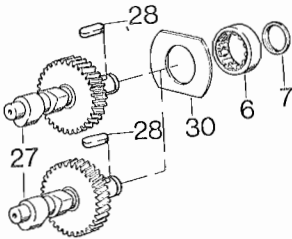
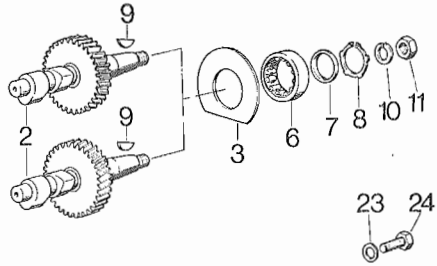
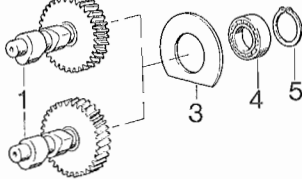

Fig. No.	Bestell-Nr. Ordering No. No. référence No de pedido	Stück Quantity Quantites Cantidades	Stück Quantity Quantites Cantidades	Hinweise Hints Indications Indicaciones
		E 573	E 673	
1	034 059 00	1	1	LK/LKF/LR
1	034 056 00	1	1	RK/RKF
2	034 300 00	1	1	LN/LNF/LHK
2	034 058 00	1	1	RN/RNF/RHK
3	032 093 00	1	1	
4	500 129 00	1	1	LK/LKF/RK/RKF/LR
5	500 209 00	1	1	LR/LK/LKF/RK/RKF 30x1,5xDIN 471
6	500 622 00	1	1	LN/LNF/RN/RNF/LS/RS/LHK/RHK
7	032 780 00	1	1	LN/LNF/RN/RNF/LS/RS/LHK/RHK
8	400 379 00	1	1	LN/LNF/RN/RNF/LHK/RHK
9	500 179 00	1	1	6 x 7,5                      DIN 6888
10	500 032 00	1	1	16                             DIN 128
11	500 245 00	1	1	M 16 x 1,5                 DIN 936-17 H
12	032 092 02 D1	1	1	
13	500 129 00	1	1	DIN 625                     6006 2 RS
14	400 337 00 D1	1	1	30 x 47 x 8
15	036 124 00	2	2	LK/LN/RK/RN/LKF/LNF/RKF/RNF
15	036 124 00	1	1	LHK/RHK
16	503 212 00	1	1	LS/RS
17	—	—	—	
18	003 621 10	1	1	LK/LN/RK/RN
19	—	—	—	
20	012 368 00	1	1	LS/RS
21	—	—	—	
22	003 622 10	1	1	LKF/LNF/RKF/RNF
23	500 010 00 D5	5	5	A 10 x 16                   DIN 7603-Cu
24	500 292 00	6	6	LK/LN/RK/RN M 10x25   DIN 933-8.8
24	500 292 00	2	2	LS/RS M 10 x 25           DIN 933-8.8
24	500 292 00	4	4	LHK/RHK M 10 x 25       DIN 933-8.8
25	500 538 00	2	2	LHK/RHK M 10 x 25       DIN 912-8.8
25	500 538 00	4	4	LS/RS M 10 x 25           DIN 912-8.8
25	500 538 00	6	6	LR M 10 x 25               DIN 912-8.8
26	500 541 00	6	6	LKF/LNF/RKF/RNF M 10 x 30   DIN 912-8.8
27	039 129 00	1	1	LS
27	039 274 00	1	1	RS
28	503 214 00	1	1	6 x 6 x 14                   DIN 6885



M 04

Nockenwelle  
Camshaft  
Arbre à cames  
Árbol de levas

M 11

Steuerdeckel  
Timing cover  
Couvercle distribut  
Tapa de mando

Tafel Nr.  
Tabl. No.

05

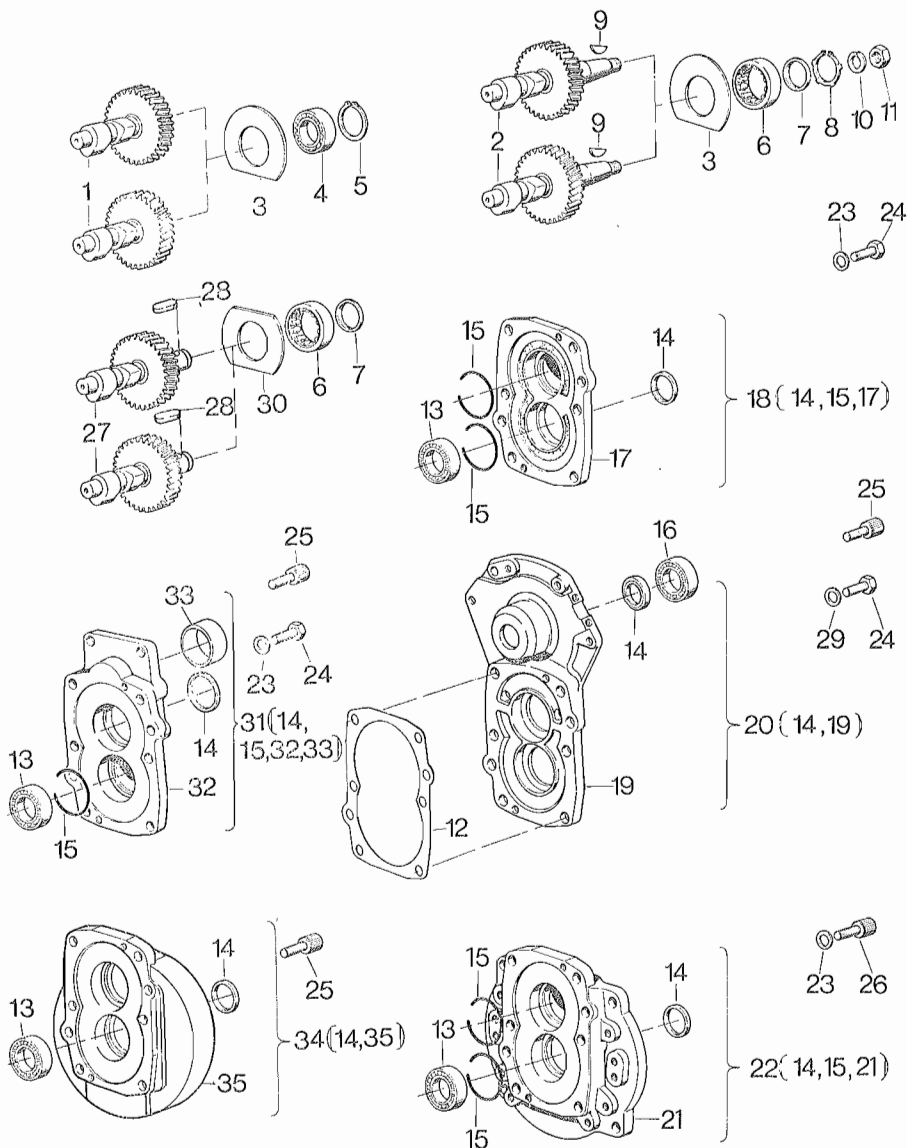

Fig. No.	Bestell-Nr. Ordering No. No. référence No de pedido	Stück Quantity Quantites Cantidades		Hinweise Hints Indications Indicaciones	
		E 573	E 673		
29	500 010 00 D5	4	4	A 10 x 16	DIN 7603-Cu
30	039 398 00	1	1	LS/RS	
31	003 623 10	1	1	LHK/RHK	
32	—	—	—		
33	400 329 00	1	1	LHK/RHK	
34	011 682 00	1	1	LR	
35	—	—	—		

M 05

Kolben, Pleuel  
Piston, conrod  
Piston, bielle  
Embolo, biela

M 06

Zylinder  
Cylinder  
Cylindre  
Cilindro

Tafel Nr.  
Tabl. No.

06

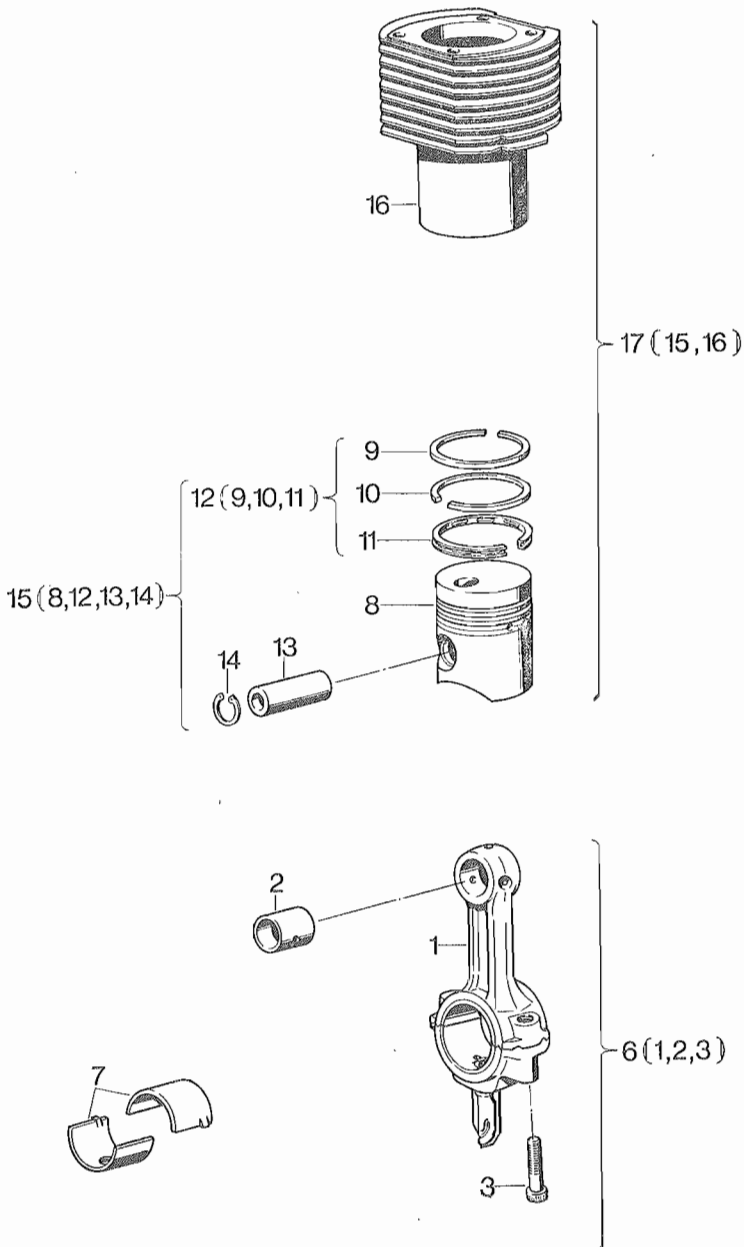

Fig. No.	Bestell-Nr.	Stück	Hinweise	
	Ordering No.	Quantity	Hints	
	No. référence	Quantites	Indications	
	No de pedido	Cantidades	Indicaciones	
		E 573	E 673	
1	--	--	--	
2	032 069 00	1	1	
3	033 937 00	2	2	
4	--	--	--	
5	--	--	--	
6	003 613 00	1	1	
7	032 067 00	1	1	
7	032 068 00	1	1	-- 0,5 mm
8	--	--	--	
9	--	--	--	
10	--	--	--	
11	--	--	--	
12	009 043 00	1	1	
12	012 340 00	1	1	+ 0,5 mm
12	009 044 00	1	1	+ 1,0 mm
13	501 075 00	1	1	
14	500 206 00	2	2	25 x 1,2
15	009 041 00	1	1	DIN 472
15	012 339 00	1	1	+ 0,5 mm
15	009 093 00	1	1	+ 1,0 mm
16	035 833 00	1	1	
17	009 127 00	1	1	

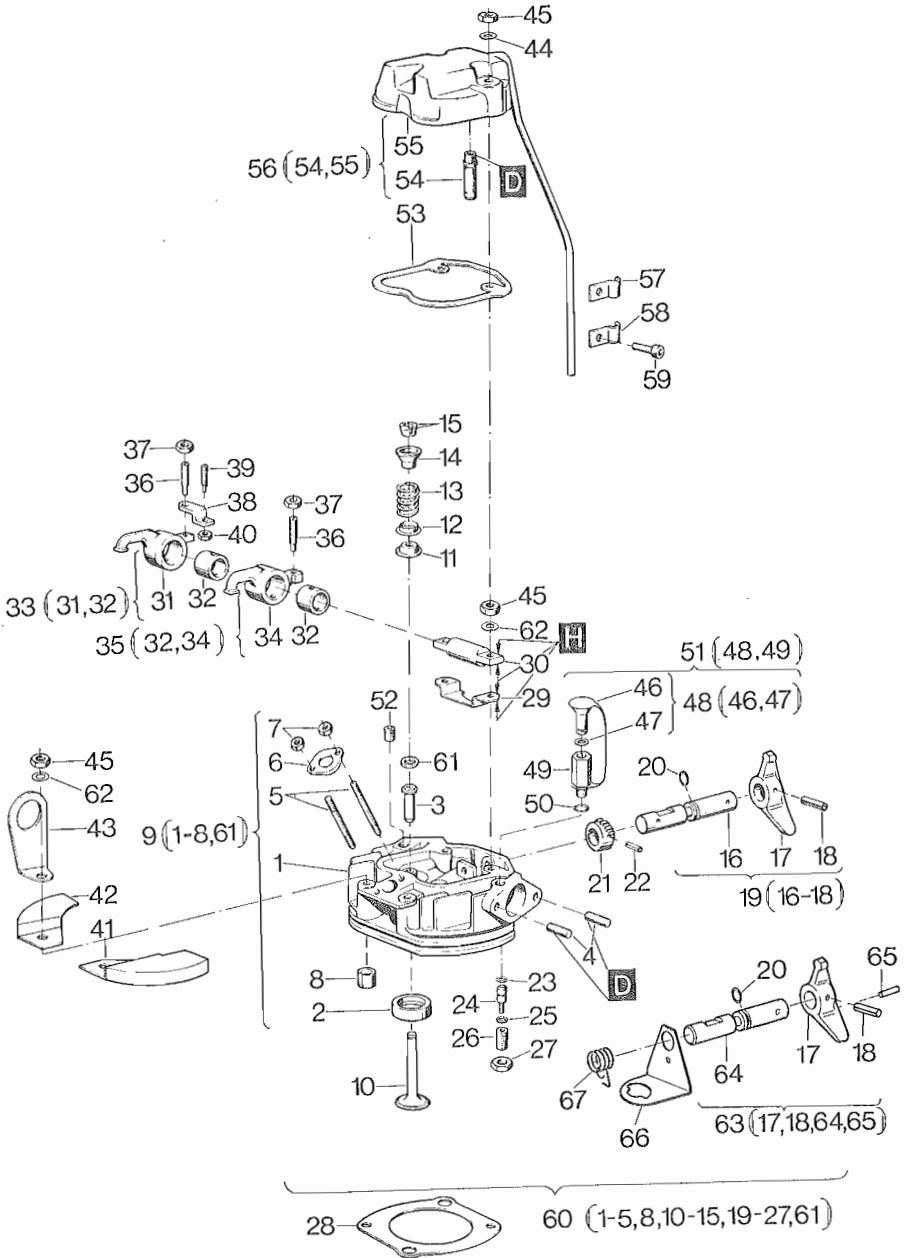

Fig. No.	Bestell-Nr.	Stück	Hinweise		
	Ordering No.	Quantity	Hints		
	No. référence	Quantités	Indications		
	No de pedido	Cantidades	Indicaciones		
		E 573	E 673		
1	—	—	—		
2	—	—	—		
3	032 082 10	2	2		
4	500 372 00	4	4	M 8 x 15	DIN 835-10.9
5	501 110 00	2	2	M 6 x 55	DIN 835-8.8
6	034 473 00	1	1		
7	500 227 00	2	2	M 6	DIN 934-8
8	500 357 00	2	2	11 x 12	DIN 7346
9	007 401 21	1	1		
10	035 698 20	2	2		
11	032 080 01	2	2		
12	032 084 00	2	2		
13	032 081 00	2	2		
14	030 605 01	2	2		
15	031 719 10	2	2		
16	—	—	—		
17	031 734 01	1	1		
18	500 346 00	1	1	4 x 18	DIN 1481
19	007 468 00	1	1		
20	501 543 00 d1	1	1		
21	035 706 00	1	1	RS/LS/RHK/LHK/LNF/LKF/LN/LK/ RNF/RKF/RN/RK	
22	500 341 00	1	1	3 x 16	DIN 1481
23	501 542 00 d1	1	1		
24	030 638 00	1	1		
25	500 426 00	10	10	A 8	DIN 2093
26	030 611 00	1	1		
27	500 238 00	1	1	BM 10	DIN 439-6
28	037 703 00	0..1	0..1	0,30 mm	
28	035 818 00 d1	0..1	0..1	0,40 mm	
28	035 819 00	0..1	0..1	0,50 mm	
28	035 820 00 d1	0..1	0..1	0,60 mm	
28	035 821 00	0..1	0..1	0,70 mm	
28	035 822 00	0..1	0..1	0,80 mm	
29	030 925 00	1	1		
30	030 615 01	1	1		
31	—	—	—		

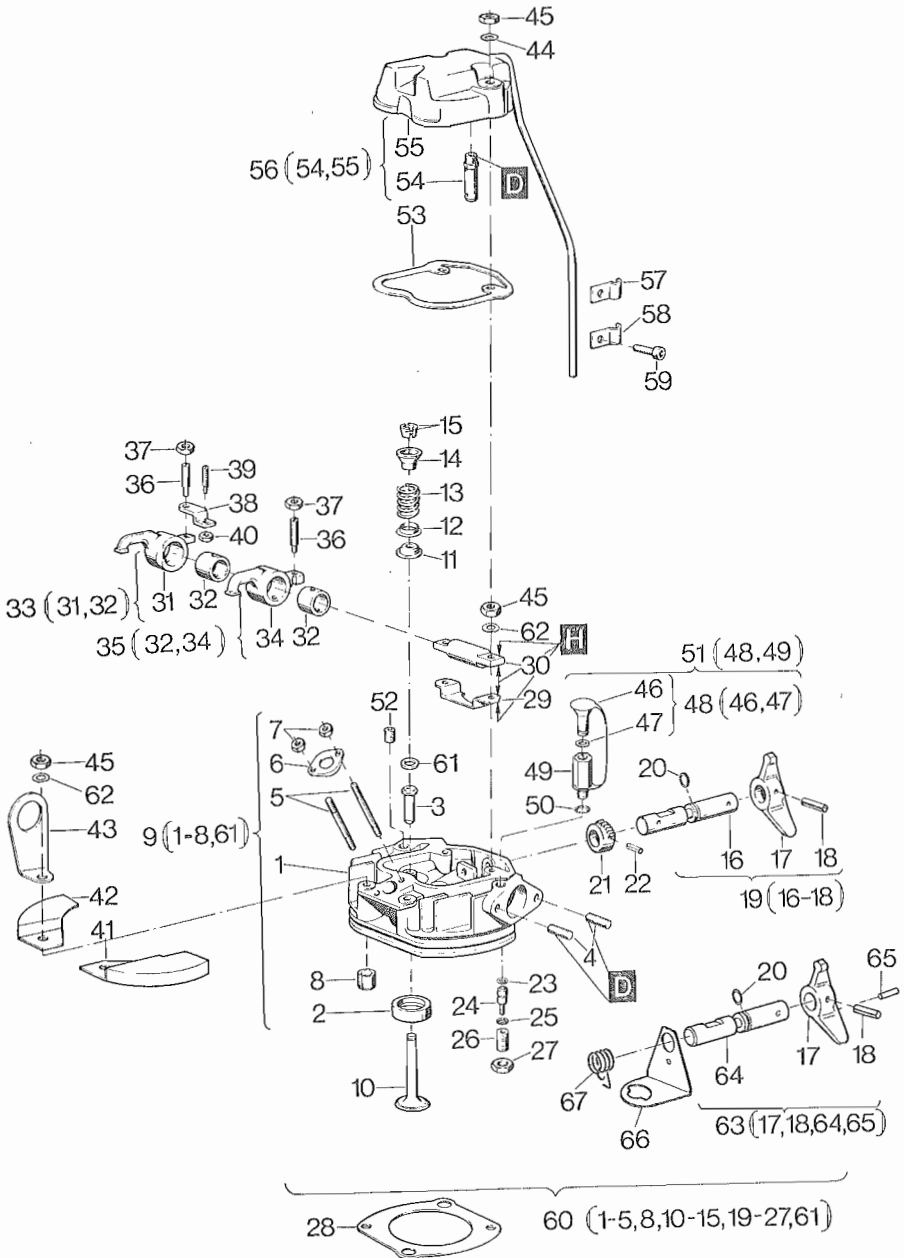

Fig. No.	Bestell-Nr.	Stück	Hinweise	
	Ordering No.	Quantity	Hints	
	No. référence	Quantites	Indications	
	No de pedido	Cantidades	Indicaciones	
		E 573	E 673	
32	034 301 00	2	2	
33	006 142 01	1	1	
34	—	—	—	
35	006 143 01	1	1	
36	030 037 00	2	2	
37	031 731 00 W2	2	2	
38	030 600 02	1	1	
39	030 220 01	1	1	
40	500 227 00 P2	1	1	M 6                      DIN 934-8
41	030 664 01	1	1	
42	030 665 01	1	1	
43	034 578 00	1	1	
44	500 035 00 W2	2	2	B 8                      DIN 137
45	500 234 00 P4/W2	6	6	M 8 x 1                DIN 934-12
46	—	—	—	
47	501 541 00 d2	2	2	
48	007 363 00 P1	1	1	
49	—	—	—	
50	500 011 00 d1	1	1	
51	003 618 01	1	1	
52	500 437 00	1	1	M 12 x 1,5            DIN 906
53	032 089.02 W3, d1	1	1	
54	003 620 04	1	1	
55	—	—	—	
56	003 138 02	1	1	
57	030 915 00	1	1	
58	031 592 00	1	1	LNF/RNF
59	500 513 00	1	1	LKF/LNF/RKF/RNF M 8 x 10 DIN 912-8.8
60	009 076 01	1	1	
61	037 538 00	2	2	
62	037 663 00 P4	4	4	
63	011 684 00	1	1	LR
64	—	—	—	
65	503 486 00	1	1	LR 3 x 26            DIN 1481
66	039 448 00	1	1	
67	039 447 00	1	1	



M 09

Stoßstange  
Pushrod  
Tige de culbuteur  
Varilla de balancín

M 14

Einspritzausrüstung  
Injection equipment  
Equipement d'injection  
Equipo de inyección

Tafel Nr.  
Tabl. No.

08

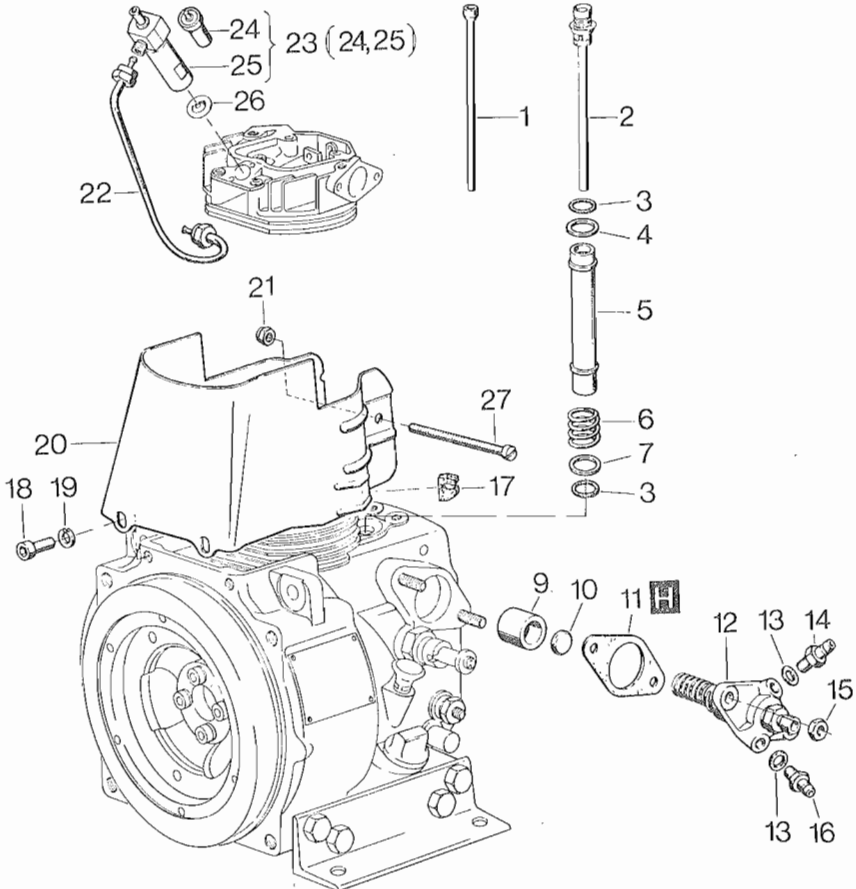

Fig. No.	Bestell-Nr. Ordering No. No. référence No de pedido	Stück Quantity Quantites Cantidades	Stück Quantity Quantites Cantidades	Hinweise Hints Indications Indicaciones	
		E 573	E 673		
1	030 639 01	1	1		
2	009 026 00	1	1		
3	502 880 00 d4	4	4	17 x 3	
4	032 091 01	2	2		
5	032 090 02	2	2		
6	031 851 00	2	2		
7	032 091 01	2	2		
8	—	—	—		
9	030 640 00	1	1		
10	030 626 00	1	1		
11	032 094 00	0..1	0..1	0,10 mm	
11	032 095 00	0..1	0..1	0,15 mm	
11	032 096 00	0..1	0..1	0,20 mm	
11	032 097 00	0..1	0..1	0,30 mm	
11	032 098 00	0..1	0..1	0,50 mm	
12	400 802 01	1	1		
13	500 011 00 D2	2	2		
14	006 710 01	1	1		
15	500 229 00	2	2	M 8	DIN 934-8
16	034 850 00	1	1		
17	031 509 00	1	1		
18	500 516 00	2	2	M 8 x 16	DIN 912-8.8
19	501 481 00	2	2	8,4	DIN 125 St A3C
20	030 666 01	1	1		
21	400 282 00	1	1	M 5	SSN 440-8 Cu
22	034 057 00	1	1		
23	400 066 00	1	1		
24	400 046 00 P1	1	1		
25	—	—	—		
26	400 031 00	1	1		
27	500 646 00	1	1	M 5 x 80	DIN 84-4.8

M 15

Andrehvorrichtung  
Starting device  
Dispositiv demarrage  
Dispositivo de arranque

M 17

Schwungrad  
Flywheel  
Volante  
Volante

Tafel Nr.  
Tabl. No.  
09

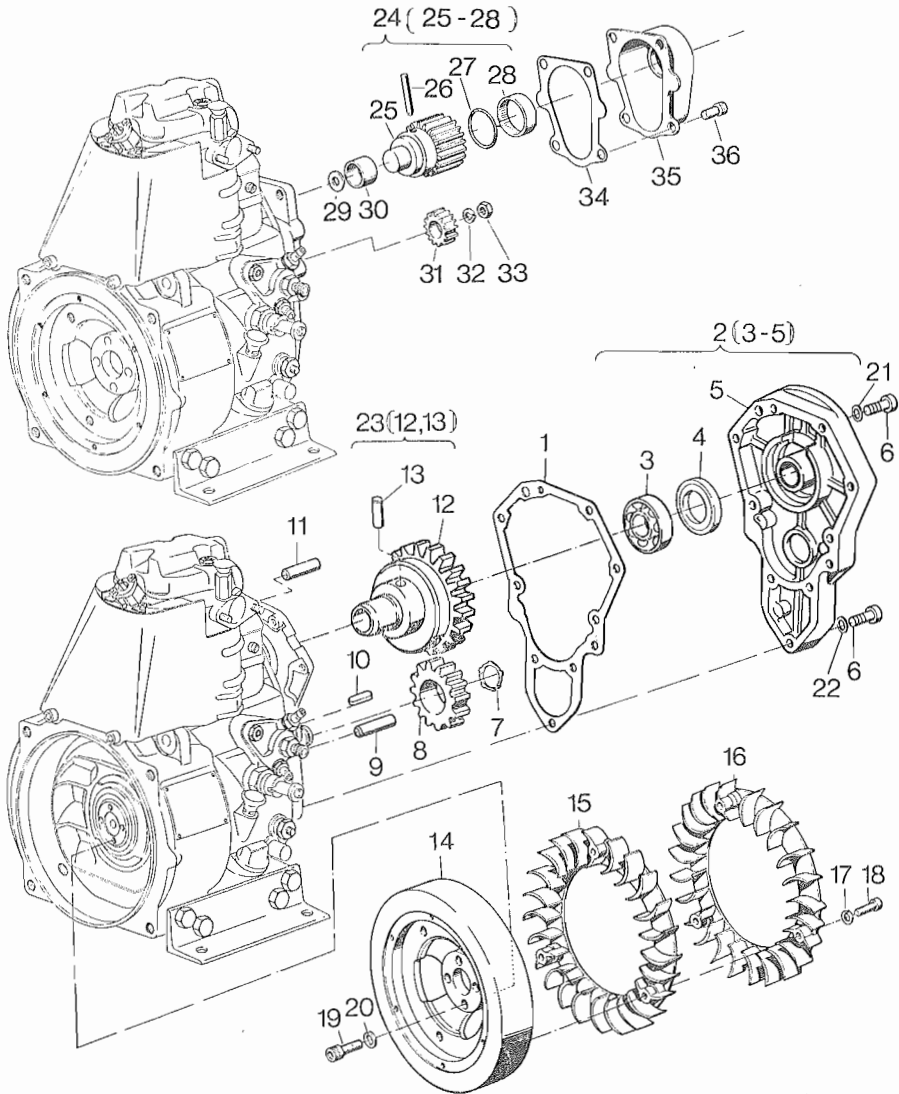

Fig. No.	Bestell-Nr.	Stück	Hinweise		
	Ordering No.	Quantity	Quantity	Hints	
	No. référence	Quantites	Indications	Indications	
	No de pedido	Cantidades	Indicaciones		
		E 573	E 673		
1	039 131 00	1	1		
2	012 318 00	1	1		
3	503 213 00	1	1		
4	400 339 00	1	1	40 x 52 x 7	
5	—	—	—		
6	500 511 00	9	9	M 6 x 30	DIN 6912-8.8
7	503 248 00	1	1	AL 22 x 1,2	
8	039 126 00	1	1		
9	500 586 00	1	1	8 M 6 x 50	DIN 7-9 S20K
10	503 214 00	1	1	A 6 x 6 x 14	DIN 6885
11	503 492 00	1	1	8 m 6 x 32	DIN 6325
12	—	—	—		
13	032 620 00	1	1		
14	030 632 01	1	1		
15	006 350 00	1	1	LK/LKF/LN/LNF/LS/LHK	
16	009 468 00	1	1	RK/RKF/RN/RNF/RS/RHK	
17	400 278 00	6	6		
18	400 356 00	6	6		
19	500 545 00	4	4	M 10 x 35	DIN 912-10.9
20	500 029 00	4	4	10	DIN 128
21	500 812 00	6	6	A 6	DIN 137 A3C
22	500 008 00	3	3	A 6,5 x 9,5	DIN 7603-Cu
23	011 663 00	1	1		
24	004 106 11	1	1	LHK/RHK	
25	—	—	—		
26	032 620 00	1	1		
27	502 524 00 D1	1	1		
28	400 190 00	1	1		
29	400 013 00	1	1		
30	400 329 00	1	1		
31	031 124 10	1	1		
32	500 032 00	1	1	16	DIN 128
33	500 245 00	1	1	M 16 x 1,5	DIN 936-17 H
34	032 100 00	1	1		
35	003 137 01	1	1		
36	500 534 00	4	4	M 10 x 16	DIN 912-8.8

**M 15**

Reversierstarter  
Recoil starter  
Demarreur reversible  
Arrancador reversible

Tafel Nr.  
Tabl. No.

10

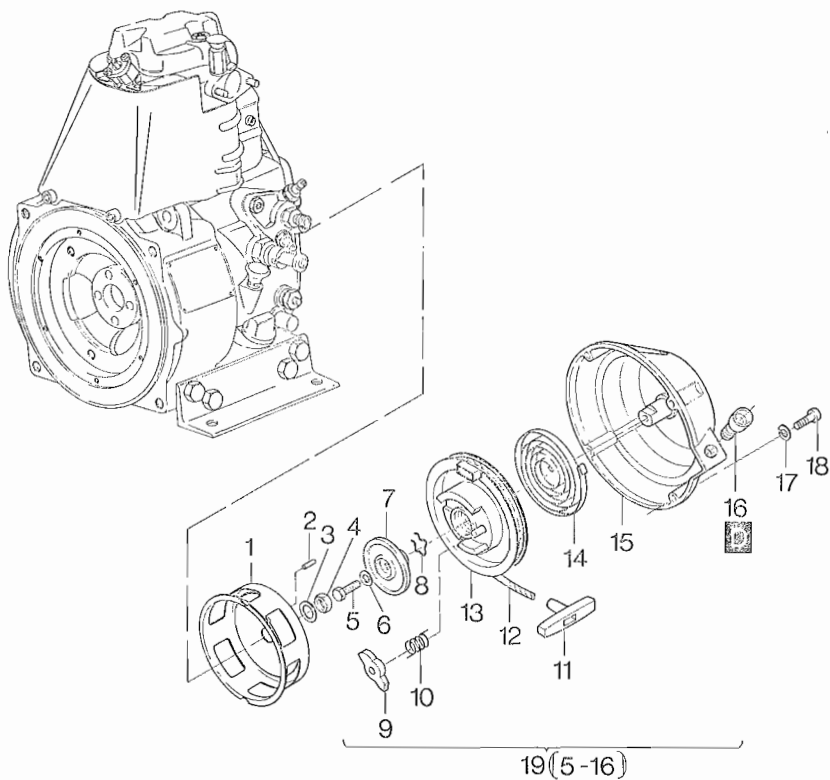

Fig. No.	Bestell-Nr.	Stück	Hinweise		
	Ordering No.	Quantity	Hints	Indications	Indicaciones
	No. référence	Quantites			
	No de pedido	Cantidades			
		E 573	E 673		
1	011 667 00	1	1		
2	503 489 00	1	1	4 m 6 x 6	DIN 7
3	503 488 00	1	1	12	DIN 6796 FST
4	500 635 00	1	1	M 12	DIN 936-17 H A3C
5	501 463 00	1	1	M 6 x 18	DIN 933
6	501 656 00	1	1	6,5 x 14	DIN 6904 A3C
7	503 483 00	1	1		
8	503 481 00	1	1		
9	503 479 00	1	1		
10	503 482 00	1	1		
11	503 485 00	1	1		
12	503 484 00	1	1		
13	503 478 00	1	1		
14	503 480 00	1	1		
15	039 446 00	1	1		
16	039 468 00	1	1		
17	500 812 00	4	4	A 6	DIN 137
18	501 706 00	4	4	M 6 x 20	DIN 912
19	011 727 00	1	1		

A 01

Kraftstoffbehälter  
Fuel tank  
Reservoir à carburant  
Depósito combustible

Tafel Nr.  
Tabl. No.

11

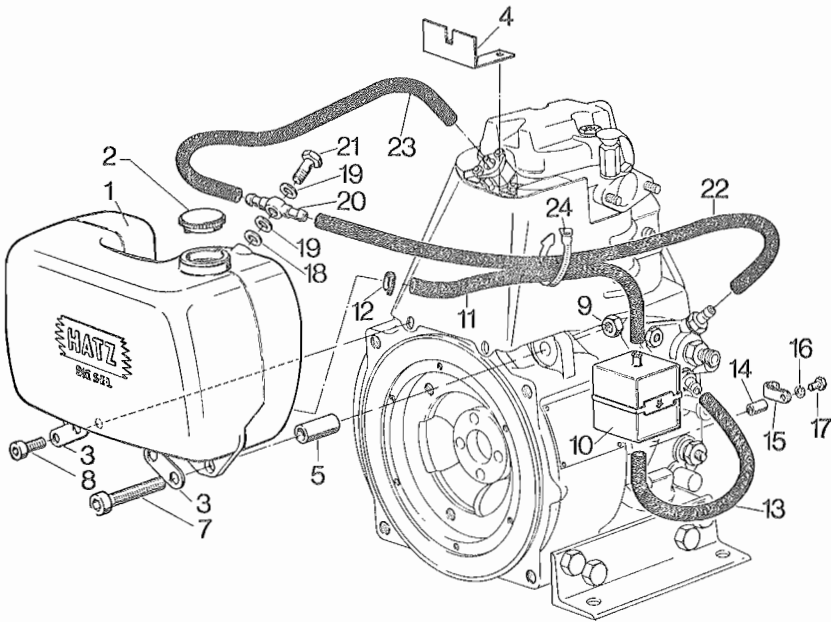

Fig. No.	Bestell-Nr. Ordering No. No. référence No de pedido	Stück Quantity Quantites Cantidades		Hinweise Hints Indications Indicaciones	
		E 573	E 673		
1	006 913 00	1	1		
2	400 326 11 P1	1	1		
3	035 258 00	4	4		
4	034 929 00	1	1		
5	034 930 00	2	2		
6	—	—	—		
7	501 716 00	2	2	M 8 x 65	DIN 912-8.8 A3C
8	501 715 00	2	2	M 8 x 25	DIN 912-8.8 A3C
9	400 284 00	2	2	M 8	SN 440-8 Cu
10	400 894 01 W2	1	1		
11	034 931 00	1	1	7 x 2,5 - 60 mm	
12	400 373 00	1	1		
13	034 935 00	1	1	7 x 2,5 - 200 mm	
14	030 427 00	1	1		
15	031 655 00	1	1		
16	501 656 00	1	1	6,5 x 14	DIN 6904-A3C
17	501 687 00	1	1	M 6 x 35	DIN 912-8.8
18	501 583 00	1	1	10,5	DIN 125-Cu
19	500 624 00 D2	2	2	A 10 x 13,5	DIN 7603-Cu
20	400 933 00	1	1		
21	501 697 00	1	1	C 4	DIN 7623-A3C
22	034 936 00	1	1	7 x 2,5 - 330 mm	
23	034 933 00	1	1	7 x 2,5 - 140 mm	
24	400 927 00	1	1		



A 02

Luftfilter  
Air filter  
Filtre à air  
Filtro de aire

A 03

Auspufftopf  
Exhaust silencer  
Silencieux  
Silenciador

Tafel Nr.  
Tabl. No.

12

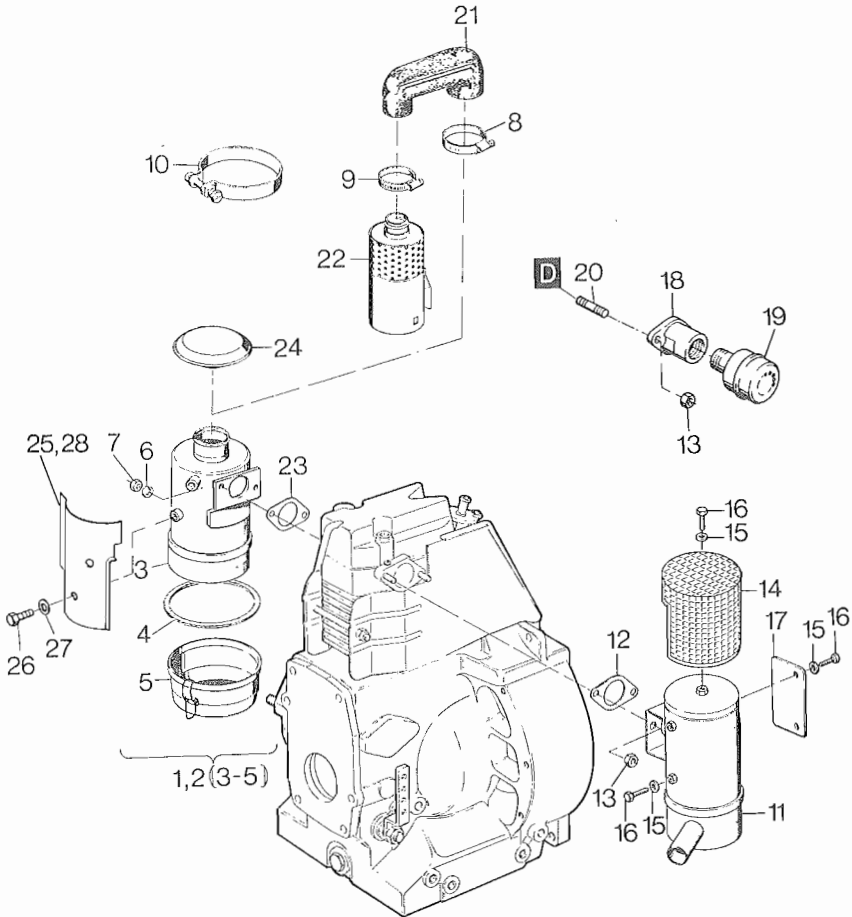

Fig. No.	Bestell-Nr. Ordering No. No. référence No de pedido	Stück Quantity Quantites Cantidades		Hinweise Hints Indications Indicaciones	
		E 573	E 673		
1	011 544 00	1	1	LS	
2	400 994 00	1	1		
3	—	—	—		
4	490 375 00 P1	1	1		
5	490 376 00	1	1		
6	502 085 00	2	2	8	DIN 128-A3C
7	500 230 00	2	2	M 8 Ms	DIN 934-Ms
8	400 535 00	1	1		
9	400 715 00	1	1		
10	401 010 00	1	1		
11	008 649 00	1	1		
12	501 224 00 d1	1	1		
13	400 816 00	2	2		
14	007 852 00	1	1		
15	500 168 00	6	6	8,4 Ms	DIN 125-Ms
16	501 731 00	4	4	M 8 x 10	DIN 912-8.8 Zn
17	036 997 00	1	1		
18	038 290 00	1	1		
19	008 722 00	1	1		
20	500 378 00	2	2	M 8 x 22	DIN 835
21	033 245 00	1	1		
22	400 996 00	1	1		
23	034 772 00 W1, d1	1	1		
24	400 995 00 P1	1	1		
25	039 330 01	1	1	LS	
26	503 335 00	2	2	M 6 x 8	DIN 933-8.8 A3C
27	501 445 00	2	2	6,4	DIN 125-St A3C
28	039 401 00	1	1	LS/RS	f. Taf., Tabl. 14, Pos. 1-20

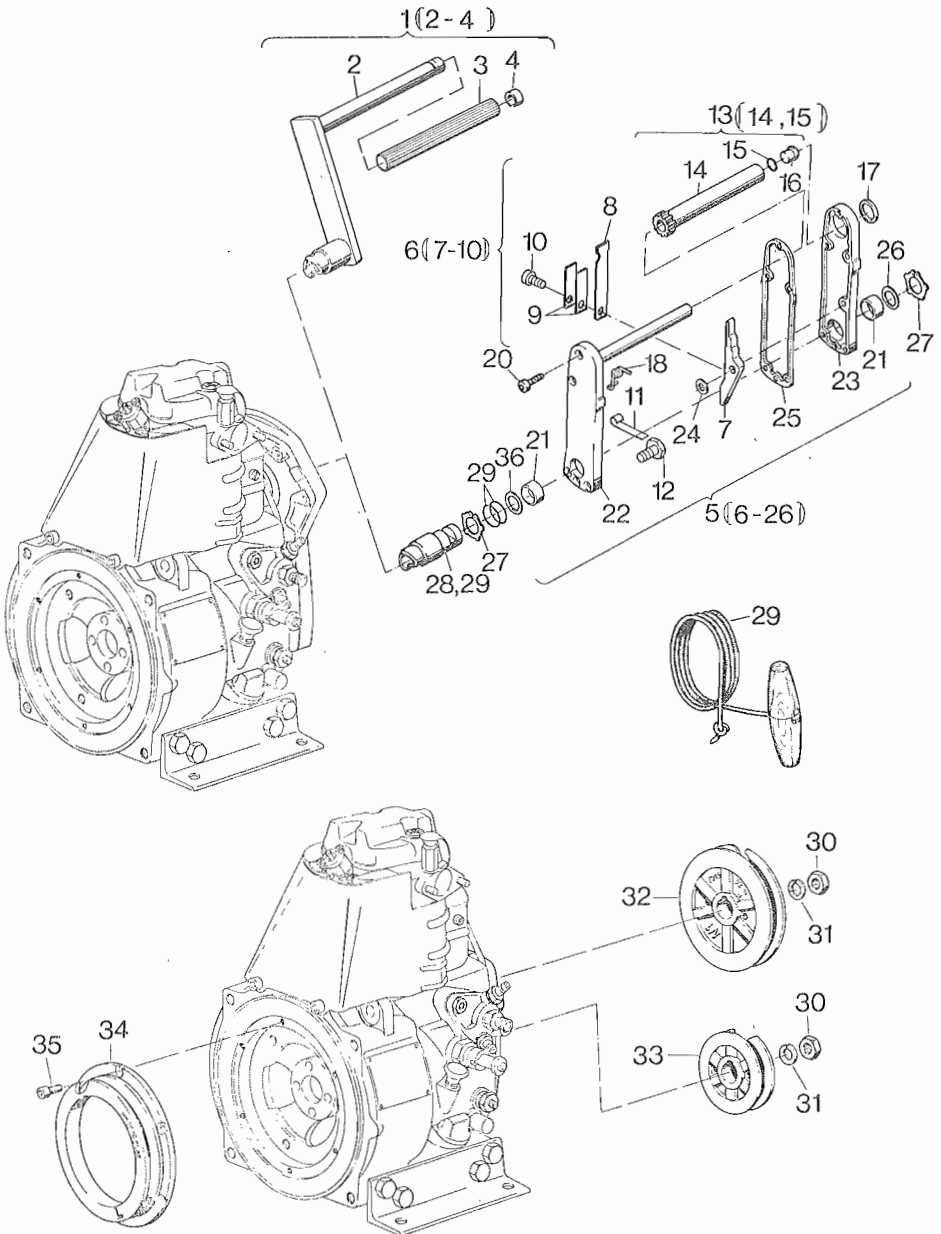

Fig. No.	Bestell-Nr. Ordering No. No. référence No de pedido	Stück Quantity Quantites Cantidades		Hinweise Hints Indications Indicaciones		
		E 573	E 673			
1	003 150 00	1	1	LHK		
1	004 241 00	1	1	RHK		
1	011 400 01	1	1	LS		
1	011 479 01	1	1	RS		
2	—	—	—			
3	035 224 00	1	1			
4	035 154 00	1	1			
5	010 279 04	1	1	„B“		
5	010 278 04	1	1	„A“		
6	010 114 03	1	1			
7	—	—	—			
8	038 121 02	1	1			
9	039 171 00	2	2			
10	503 165 00	2	2	M 5 x 8		DIN 6912-8.8
11	039 556 00	1	1			
12	039 549 00	1	1			
13	010 113 10	1	1			
14	—	—	—			
15	501 691 00	1	1	19 x 1,8		
16	501 992 00	1	1			
17	501 942 00	1	1			
18	039 559 00	1	1	„A“		
18	039 560 00	1	1	„B“		
19	—	—	—			
20	501 944 00	5	5	M 6 x 25		DIN 6912-8.8 A3C
21	501 934 00	2	2			
22	—	—	—			
23	—	—	—			
24	501 958 00	1	1	10 x 16 x 0,5		DIN 988
25	038 130 00	1	1			
26	039 286 00	2..4	2..4	30 x 38 x 0,15		
27	501 943 00	2	2	A 30 x 1,5 K		DIN 983
28	010 186 00	1	1	LHK 50 mm		
28	011 399 00	1	1	LS 50 mm		
28	010 188 00	1	1	LHK 108 mm		
28	010 475 00	1	1	LHK 177 mm		

A 04

Andrehkurbel, Startscheibe  
Starting handle, starter pulley  
Manivelle, poulie lancement  
Manivela, polier de arranque

Tafel Nr.  
Tabl. No.

13

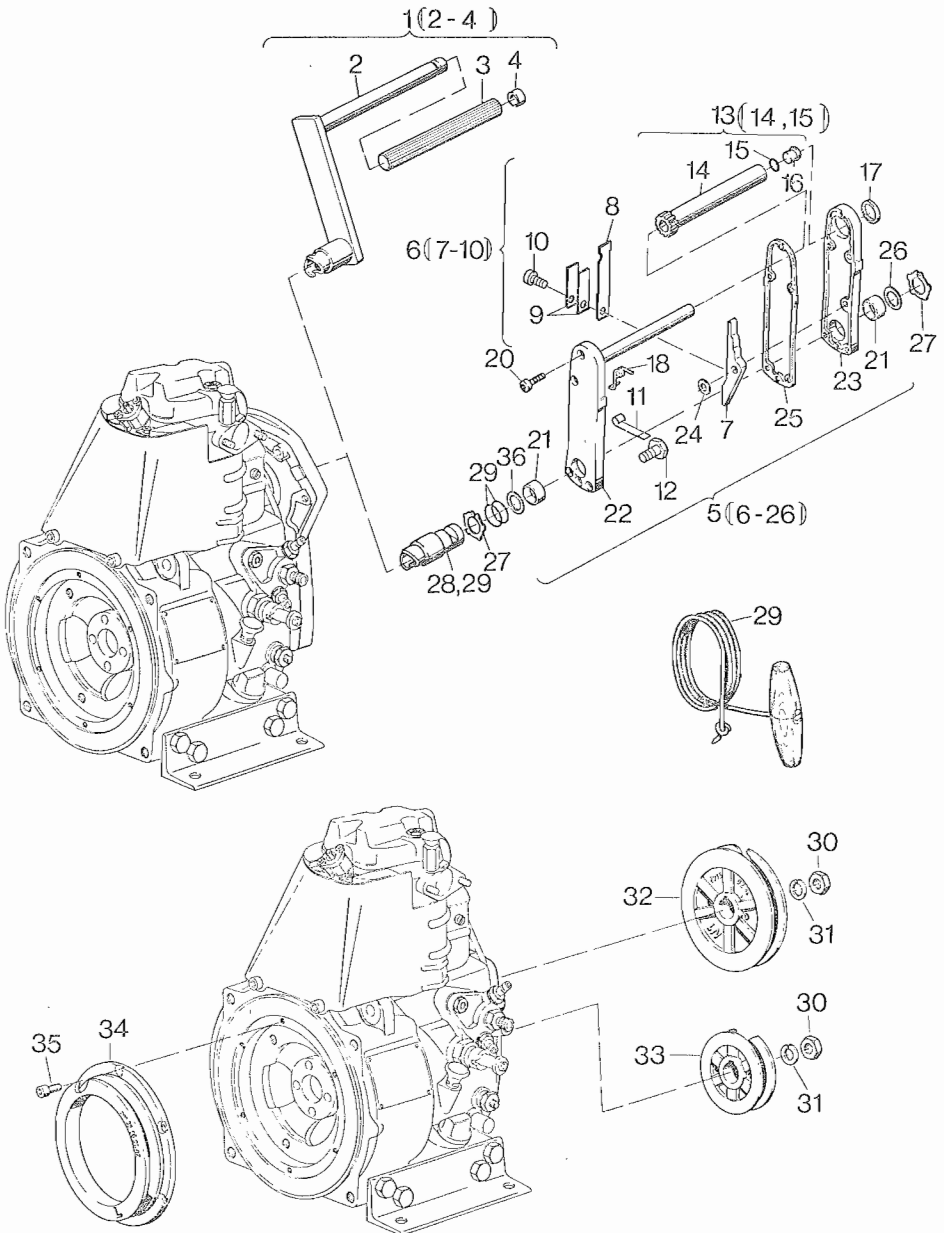

Fig. No.	Bestell-Nr. Ordering No. No. référence No de pedido	Stück Quantity Quantites Cantidades		Hinweise Hints Indications Indicaciones	
		E 573	E 673		
29	011 480 00	1	1	RS 50 mm	
29	010 187 00	1	1	RHK 50 mm	
30	500 245 00	1	1	M 16 x 1,5	DIN 936-17 H
31	500 032 00	1	1	16	DIN 128
32	030 019 02	1	1	LN	
32	030 901 02	1	1	RN	
33	030 902 02	1	1	LK	
33	030 900 02	1	1	RK	
34	030 788 02	1	1	LK/LKF/LN/LNF	
34	030 789 02	1	1	RK/RKF/RN/RNF	
35	500 507 00	6	6	M 6 x 16	DIN 6912 - 8.8
36	502 585 00	2	2	26 x 1,5	

**A 09**

Drehzahlverstellung  
Speed control  
Reglage regime  
Ajuste de velocidad

**A 16**

Wellenstummel, Zentrierflansch  
stubshaft, cent. flange flyw. side  
bout de arbre, bride centr. c. vol.  
eje, brida de centrage

Tafel Nr.  
Tabl. No.  
14

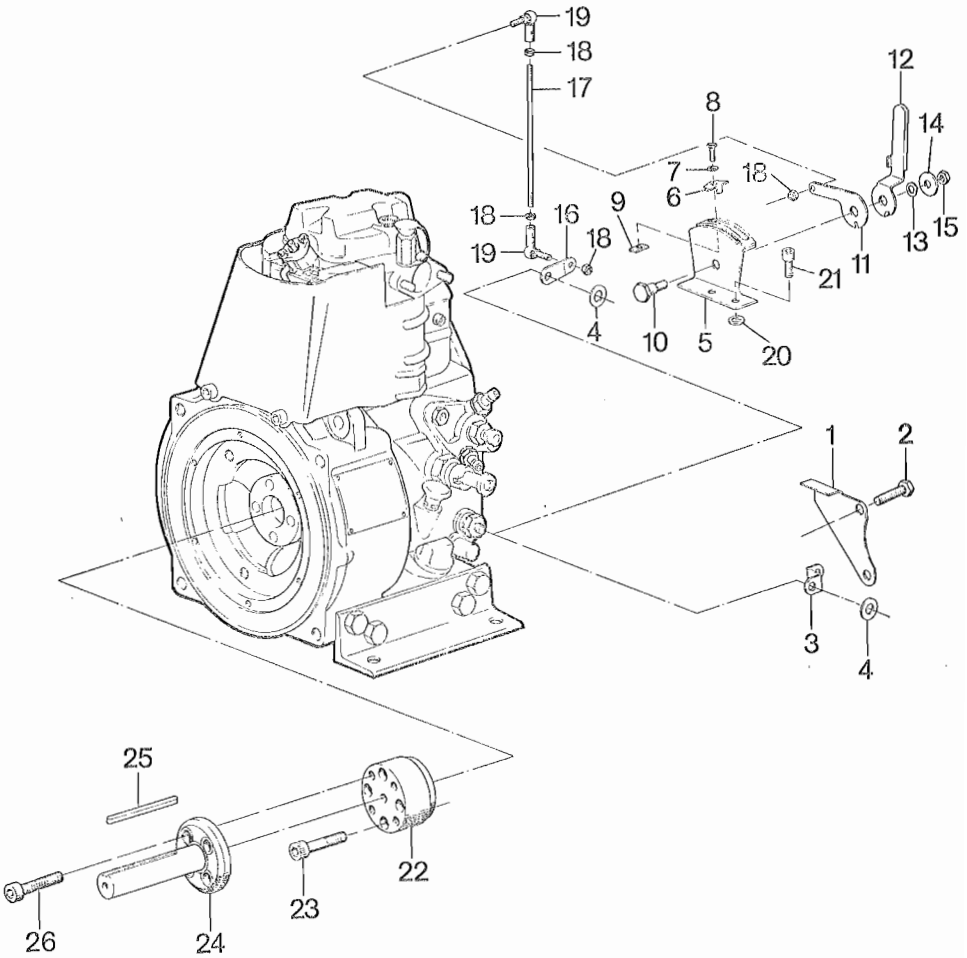

Fig. No.	Bestell-Nr. Ordering No. No. référence No de pedido	Stück Quantity Quantites Cantidades		Hinweise Hints Indications Indicaciones
		E 573	E 673	
1	039 164 00	1	1	LKF, LNF, RKF, RNF
1	031 082 00	1	1	L, LK, LN, R, RK, RN
2	500 293 00	2	2	M 10 x 30          DIN 933-8.8
3	031 081 00	1	1	
4	031 056 00	1	1	
5	007 204 00	1	1	
5	011 458 00	1	1	LS
6	031 122 00	2	2	
7	502 163 00	2	2	5,3                  DIN 125-St A3C
8	500 251 00	2	2	M 5 x 10          DIN 933-8.8
9	031 121 01	2	2	
10	035 117 00	1	1	
11	035 116 00	1	1	
11	039 287 00	1	1	LS
12	035 115 00	1	1	
12	039 276 00	1	1	LS
13	500 035 00	1	1	B 8                  DIN 137
14	500 629 00	1	1	B 8,4                DIN 9021-St
15	500 232 00	2	2	BM 8                DIN 439-5
16	035 119 00	1	1	
17	035 110 00	1	1	
17	039 288 00	1	1	LS
18	500 227 00	4	4	M 6                  DIN 934-8
19	501 333 00	2	2	
20	500 167 00	4	4	8,4                  DIN 125-St
21	500 520 00	2	2	M 8 x 20          DIN 6912-8.8
22	030 947 00	1	1	
23	500 548 00	4	4	M 10 x 45          DIN 912-10.9
24	030 273 00	1	1	
25	500 117 00	1	1	A 8 x 7 x 63        DIN 6885
26	500 538 00	4	4	M 10 x 25          DIN 912-8.8



### **Anhang für nicht abgebildete Zusatzausrüstung:**

Weitere Zusatzausrüstungen können aus Platzgründen in der Ersatzteilliste nicht mehr detailliert dargestellt werden. Für die Bestellung von Teilen aus nicht abgebildeten Zusatzausrüstungen verwenden Sie bitte nachfolgende Übersicht. Anhand der Skizze ist die gesuchte Zusatzausrüstung auffindbar, die für den jeweiligen Motortyp zugehörige Ident-Nr. der Ausrüstung ist aus der Tabelle ersichtlich. Ihre zuständige HATZ-Vertretung kann Ihnen anhand dieser Ident-Nr. das gewünschte Ersatzteil heraussuchen.

### **Annex for additional equipment with is not illustrated:**

Due to lack of space we cannot list further additional equipment in our parts list: For parts ordering not illustrated, please use the below listed survey. With the aid of sketches you can find the required additional equipment. The ident-number belonging to the corresponding engine type can be taken from the table. Your HATZ agent is in a position to select for you the required spare part as soon as you have selected the correct ident-number.

### **Annexe concernant les accessoires complémentaires non-illustrés:**

Un certain nombre d'accessoires complémentaires n'ont pu, par suite d'un manque de place, être représentés d'une manière détaillée dans la liste de pièces détachées. Pour la commande de ces accessoires, qui ne sont pas illustrés, veuillez utiliser l'aperçu ci-après. A l'aide des croquis, il est possible de trouver l'accessoire souhaité, le No. ident. correspondant pour chaque type de moteur figure dans le tableau. Grâce à ce No. ident. votre représentant HATZ pourra vous trouver la pièce souhaitée.





### **En relación a equipos adicionales no ilustrados.**

Debido a razones de espacio no es posible ilustrar otros equipos adicionales en la lista de piezas. Para pedidos de equipos adicionales no ilustrados favor usen la siguiente orientación. A base de las ilustraciones es posible encontrar el equipo adicional buscado, el número ident para el tipo de motor para el cual se necesita el equipo se puede obtener de la tabla.

El representante HATZ para su area puede entonces a base del número ident encontrar las piezas deseadas.

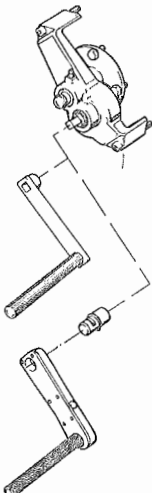

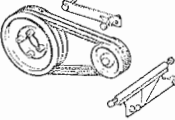
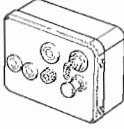

**Zusatzausrüstungen**  
**Equipements**  
**Accessoires complémentaires**  
**Equipos**

**Hinweise**  
**Hints**  
**Indications**  
**Indications**

	Code	Ident-Nr.	E 573	E 673
	A 04.70	005 843 01	L	L
	A 04.70	005 844 01	R	R
	A 04.70	010 444 00	X	X
	A 04.70	010 180 01	L	L
	A 04.70	010 443 00	R	R
		A 05.20	004 752 02	R
A 05.20		004 750 02	RK	L/RK
	A 05.30	004 751 01	L/R	L/
	A 05.30	004 746 01	LK/RK	LK/RK
	A 05.60	007 795 01	X	X
	A 05.60	007 161 02	X	X
	A 08.10	004 063 00	X	X

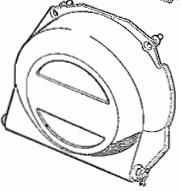
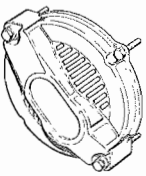
Zusatzausrüstungen  
 Equipements  
 Accessoires complémentaires  
 Equipos

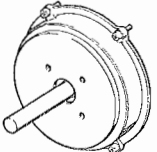
Hinweise  
 Hints  
 Indications  
 Indications

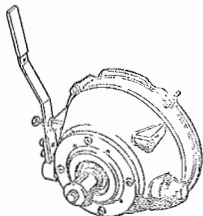
	Code	Ident-Nr.	E 573	E 673	
	A 12.20	006 245 00	X	X	
	A 12.20	006 247 00	X	X	
	A 12.20	006 246 00	X	X	
	A 12.20	007 280 00	X	X	
	A 12.20	008 681 00	X	X	
<hr/>					
	A 16.20	004 741 00	X	X	
	A 16.20	006 824 00	X	X	
	A 15.20	011 317 00	X	X	
	A 16.20	011 321 00	X	X	
	A 15.20	011 322 00	X	X	
	A 16.20	011 321 00	X	X	
	A 16.30	004 740 00	X	X	
	A 16.30	004 744 00	X	X	
<hr/>					
	A 17.11	004 753 00	X	X	

Zusatzausrüstungen

Equipements

Accessoires complémentaires

Equipos

Hinweise

Hints

Indications

Indications

	Code	Ident-Nr.	E 573	E 673	
--	------	-----------	-------	-------	--



A 17.30	004 048 00	X	X	
A 17.30	004 049 00	X	X	



A 17.50	004 864 00	X	X	
A 17.50	004 865 00	X	X	

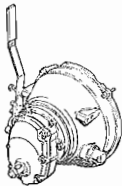

A 20.10	004 803 01	X	X	i = 1,8
A 20.10	004 799 00	X	X	i = 2,8
A 21.10	004 855 00	X	X	i = 10,4



A 20.10	004 962 02	LKF, LNF	LKF, LNF	i = 1,8
		RKF, RNF	RKF, RNF	
A 21.10	004 963 01	LKF, LNF	LKF, LNF	i = 2,8
		RKF, RNF	RKF, RNF	
A 21.10	004 966 01	LKF, LNF	LKF, LNF	i = 6,6
		RKF, RNF	RKF, RNF	
A 21.10	004 964 01	LKF, LNF	LKF, LNF	i = 10,4
		RKF, RNF	RKF, RNF	

**Serien-Nr.-Änderungen**  
**Serial-code modification list**  
**Modification des Nos de serien**  
**Modificación de los Nos de serie**

Bildtafel	Pos. Nr.	Bestell-Nr.	Stück	Bildtafel	Pos. Nr.	Bestell-Nr.	Stück	IMT No.
Table	Fig. No.	Ordering No.	Qty.	Table	Fig. No.	Ordering No.	Qty.	
Planche	Fig. No.	No. référence	Qté.	Planche	Fig. No.	No. référence	Qté.	
Tabla	Fig. No.	No. de pedido	Cant.	Tabla	Fig. No.	No. de pedido	Cant.	

**E 573.10**

**E 673.11**

**E 673.10**

**E 573.11**

83.413

06	3	032 032 00	2	07	3	032 082 10	2	
06	9	007 401 20	1	07	9	007 401 21	1	
06	10	035 698 10	2	07	10	035 698 20	2	
06	15	032 033 01	2	07	15	031 719 10	2	
06	61	—	—	07	61	037 538 00	2	
08	16	502 580 00	4	08	03	502 880 00	4	—