

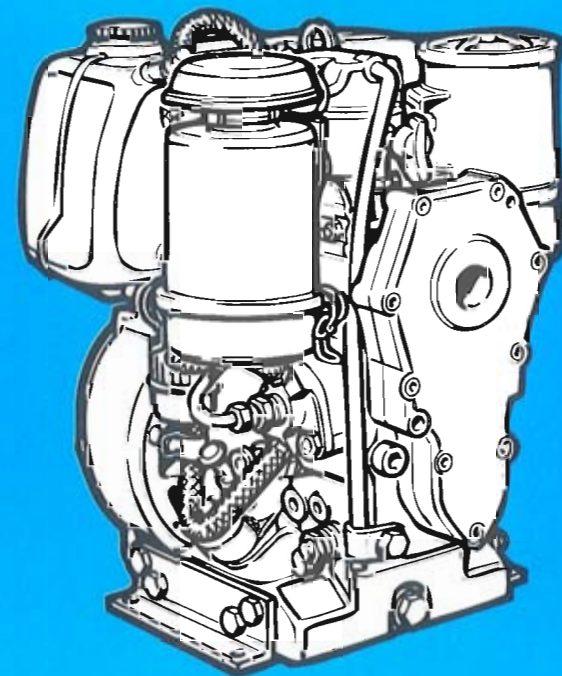

MOTORENFABRIK HATZ • D-94099 Rühstorf • Germany
Tel.: 0 85 31 / 319 - 0 • Telex: 57 260 • Telefax: 0 85 31 / 319 418

34/351 - 10.93 - 5.
Printed in Germany
Schutzgebühr DM 3.-
Protection tax
Taxe de protection
Derecho de proteccion
Tassa di protezione

Ersatzteil-Liste
Spare parts list
Liste des pièces de rechange
Lista de recambios
Catalogo ricambi



E 573...
E 673...

No. E 573.11
No. E 673.11

Bitte hier **Typ, Motornummer** und **Drehzahl** (siehe Motor-Typenschild) eintragen.

Enter here **type engine no.** and **rpm.** (see engine type-plate).

Indiquer ici le **type, N° de moteur** et **régime** (voir plaque signalétique).

Insertar aquí **tipo- N° motor** y **r.p.m.** (vea placa del motor).

Indicare qui il **tipo del motore, la matricola** e il **regime** (vedi targhetta).

MOTORENFABRIK HATZ <small>SMBH</small> <small>CO</small> KG			
D-94099 RUHSTORF			
TYP	KENNZ.		
MOTOR/FABRIK NO.		ABE/AUSE.	
MIN ^r	NH	PV	CM ³
HATZ			
DIESEL			
MADE IN GERMANY			

Ersatzteilliste Nr.

Spare parts list no.

Liste des pièces de rechange no.

Lista de recambios no.

Catalogo ricambi n.

E 573.11

E 673.11

Bitte tragen Sie hier die **Anschrift** Ihrer nächsten HATZ-Servicestelle ein.

Insert here **address** of your next HATZ Service station.

Indiquer ici l'**adresse** de votre station service HATZ la plus proche.

Insertar aquí **dirección** de servicio HATZ más cercano.

Indicare qui l'**indirizzo** dell'officina HATZ a voi più vicina.

HATZ-Service

MOTORENFABRIK HATZ
D - 94099 RUHSTORF • Germany

Angaben bei Ersatzteilbestellungen:

Zur richtigen und schnellen Belieferung mit Ersatzteilen sind folgende Angaben erforderlich:

1. **Type, Motornummer und Drehzahl** des Motors, für den das Ersatzteil benötigt wird: siehe Angaben auf Seite 1.
2. **Nummer der Ersatzteilliste**, aus der die Bestellnummer herausgelesen wurde: siehe Seite 1.
3. **Stückzahl und Bestell-Nr.** des gewünschten Ersatzteils
4. Gewünschte **Versandart**, z.B. Post, Luftfracht, Express.
5. Genaue **Versandadresse**, wenn erforderlich mit Post- und Bahnstation.

Bestellbeispiel:

Für Motortyp:	E 673 LK
Motornummer:	561193054622
min ⁻¹ :	3000/60

aus Ersatzteilliste: E 673.11
folgende Teile:

Stück	Bestell-Nr.
2	500 246 00
6	032 062 00

per Postexpress an....

Die Ersatzteilbestellung richten Sie bitte an:

–die nächste HATZ-Service-stelle, Anschrift siehe Seite 1, oder separates Service-stellenverzeichnis

–oder an die

Motorenfabrik HATZ GmbH & Co. KG
D-94099 Ruhstorf
Germany
Tel. 08531 / 319-0
Telex 57260
Telefax 08531 / 319 418

Particulars for spare parts orders:

The following information is needed to ensure correct and prompt supply of spare parts:

1. **Engine type, engine number and r.p.m.** of the engine for which you need the spare part.
See particulars on page 1.
2. **Number of spare parts list** from which you took the ordering no., see page 1.
3. **Quantity and ordering no.** of requested spare part.
4. Requested **mode of dispatch**, e.g. surface/airmail, airfreight, express.
5. Exact **shipping address**, if necessary indicate local post office and/or railway station.

Example for your order:

For engine type	E 673 LK
Engine number	561193054622
R.p.m.	3000/60

Spare parts list no. E 673.11

The following parts:

Qty.	ordering-no.
2	500 246 00
6	032 062 00

to be mailed, express, to...

Please address your spare parts order to:

–your nearest HATZ service station, address see page 1, or separate HATZ-service-list

–or to

Motorenfabrik HATZ GmbH & Co. KG
D - 94099 Ruhstorf
Germany
Tel. 08531 / 319-0
Telex 57260
Telefax 08531 / 319 418

Données à indiquer lors de vos commandes de pièces détachées:

Pour nous permettre de livrer vos pièces rapidement et correctement, nous avons besoin des données suivantes:

1. **Type, No. et régime du moteur** pour lequel vous avez besoin de pièces: voir données page 1.
2. **No de la liste de pièces de rechange** dans laquelle figure le No. de commande: voir page 1.
3. **Quantité et No. de commande** de la pièce souhaitée.
4. **Mode d'expédition** souhaitée: par ex. par poste, frêt aérien, exprès.
5. **Adresse** exacte de **destination** et, lorsque ceci est nécessaire, le nom de la poste et de la gare, ou aeroport.

Exemple:

Pour type de moteur: E 673 LK
No. moteur: 561193054622
Régime: 3000/60
Liste de pièces de rechange: E 673.11
Les pièces suivantes:

Qté.	No. commande
2	500 246 00
6	032 062 00

par poste exprès à...

Les commandes de pièces détachées sont à adresser à:

–votre station-service HATZ la plus proche, voir adresse page 1, ou liste en service séparée.

–ou

Motorenfabrik HATZ GmbH & Co. KG
D - 94099 Ruhstorf
Allemagne
Tel. 08531 / 319-0
Telex 57260
Telefax 08531 / 319 418

Datos para pedidos de recambios:

Para recibir sus recambios en forma rápida y correcta necesitamos las siguientes informaciones:

1. **Tipo, número del motor y revoluciones:**
ver detalles en página 1.
2. **Número de la lista de recambios** de la cual se ha obtenido el número de pedido: ver página 1.
3. **Cantidad y número de pedido** del recambio deseado.
4. Tipo de **despacho deseado:** por ej. correo, fiete aereo, expreso etc.
5. **Dirección** exacta, si necesario indicar la oficina de correo, la estación ferrocarril o aeropuerto.

Ejemplo de pedido:

Para motor tipo: E 673 LK
Número de motor: 561193054622
R.P.M. 3000/60

De la lista de recambios: E 673.11

Siguientes recambios:

Cantidad	Número de pedido
2	500 246 00
6	032 062 00

Por correo expreso a...

El pedido de recambios favor dirigirlo a:

–Al servicio HATZ más cercano, dirección verla en página 1, o en el indice separado de direcciones de servicio.

–Alternativa a:

Motorenfabrik HATZ GmbH & Co. KG
D - 94099 Ruhstorf
Alemania
Tel. 08531 / 319-0
Telex 57260
Telefax 08531 / 319 418

Dati da indicare al momento dell'ordine di ricambi:

Per permetterci di consegnare correttamente e con rapidità i vostri ricambi, abbiamo bisogno dei seguenti dati:

1. **Tipo motore, matricola e regime** di rotazione del motore del quale effettuate l'ordine: vedi dati pagina 1.
2. **Numero del catalogo ricambi** dal quale avete effettuato l'ordine: vedi pagina 1.
3. **Quantità e codice** del particolare desiderato.
4. **Modo di spedizione** desiderato:
es. per posta, via aerea, corriere.
5. **Indirizzo** esatto del **destinatario** e se necessario, il nome della stazione o aeroporto.

Esempio:

Per tipo di motore: E 673 LK
Matricola: 561193054622
Regime: 3000/60

Catalogo ricambi: E 673.11

I seguenti particolari:

Q.tà	Codice
2	500 246 00
6	032 062 00

con pacco postale espresso a...

Gli ordini di parti di ricambio devono essere inviati a:

–il vostro concessionario HATZ più vicino, vedi indirizzo pagina 1, oppure il libretto service HATZ.

–oppure

Motorenfabrik HATZ GmbH & Co. KG

D - 94099 Ruhstorf

Germania

Tel. 08531 / 319-0

Telex 57260

Telefax 08531 / 319 418

Inhaltsverzeichnis

Index

M ..	Grundmotor	Basic engine	
00	Ersatzteilsätze,	Spare parts kits,	01
34	Zubehör, Schilder	accessories, labels	02
01	Kurbelgehäuse	Crankcase	03
01	Drehzahlverstellung	Speed control	04
02,	Kurbelwelle	Crankshaft	05
04, 11	Nockenwelle, Steuerdeckel	Camshaft, timing cover	06
05, 06	Kolben, Pleuel, Zylinder	Piston, conrod, cylinder	07
07	Zylinderkopf	Cylinder head	08
09, 14	Stoßstange, Einspritzausrüstung	Pushrod, injection equipment	09
15, 17	Andrehvorrichtung, Schwungrad	Starting device, flywheel	10
15	Reversierstarter	Recoil starter	11

A ..	Zusatzausrüstung	Equipements	
01	Kraftstoffbehälter	Fuel tank	12
02, 03	Luftfilter, Auspufftopf	Air filter, exhaust silencer	13
04	Andrehkurbel, Startscheibe	Starting handle, starter pulley	14
09, 16	Drehzahlverstellung einstellbar, Wellenstummel, Zentrierflansch	Speed control, stubshaft, cent. flange flyw. side	15

Seite/Page

Zusatzausrüstungen	Equipements	45 – 47
Serien-Nr.-Änderungen	Serial-code modification list	48

Sommaire

Indice

M ..	Moteur de base	Motor de base	
00	Jeu de pièces de rechange,	Juegos de recambios,	01
34	accessoires, plaques	accessorios, placas	02
01	Carter moteur	Caja cigueñal	03
01	Reglage régime	Ajuste de revoluciones	04
02	Vilebrequin	Cigueñal	05
04, 11	Arbre à cames, couvercle distribution	Arbol de levas, tapa de mando	06
05, 06	Piston, bielle, cylindre	Embolo, biela, cilindro	07
07	Culasse	Culata	08
09, 14	Tige de culbuteur, Equipement d'injection	Varilla de balancín, Equipo de inyección	09
15, 17	Dispositif démarrage, volant	Dispositivo de arranque, volante	10
15	Demarreur reversible	Arrancador reversible	11

A ..	Accessoires	Equipos	
01	Reservoir à carburant	Depósito combustible	12
02, 03	Filtre à air, silencieux	Filtro de aire, silenciador	13
04	Manivelle, poulie lancement	Manivela, polier de arranque	14
09, 16	Reglage régime, bout de arbre, bride centr. c. vol.	Ajuste de velocidad. eje, brida de centraje	15

Page/Página No.

Aperçu de modifications	Tabla de modificaciones	45 – 47
Modification des Nos de serien	Modificación de los Nos de serie	48

Indice Tavola N.

M .. Motore di base

00	Serie guarnizioni	01
34	kit accessori	02
01	Basamento motore	03
01	Regolatore di giri	04
02	Albero a gomito	05
04, 11	Albero a camme	
	coperchio distribuzione	06
05, 06	Pistone, biella, cilindro	07
07	Testa	08
09, 14	Asta bilancieri,	
	Equipaggiamento di iniezione	09
15, 17	Dispositivo di avviamento, volano	10
15	Avviamento a strappo	11

A .. Accessori

01	Serbatoio e circuito combustibile	12
02, 03	Filtro aria, marmitta	13
04	Manovella,	
	puleggia per avviamento	14
09, 16	Comando acceleratore, contralbero,	
	flangia di centraggio	15

Pagina

Predisposizioni 45 – 47

Modifica dei codici 48

MOO

Ersatzteilsätze
Spare parts kits
Jeux de pièces de rechange
Juegos de piezas de recambios
Serie guarnizioni

Tafel Nr.
Tabl. No.
Tavola N.

01

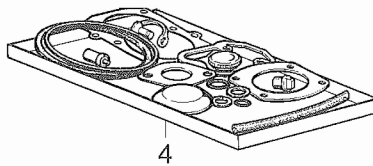
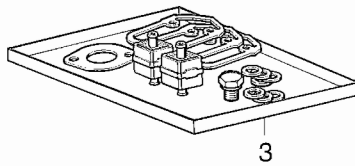
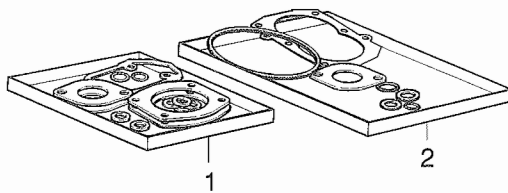
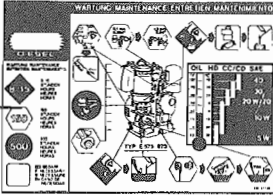

Fig.-No.	HATZ Ident-No.	Stück Qty.	P / W d / D	Bemerkungen Notes	
		E 573	E 673		
				<p>W: Im Wartungssatz enthalten. Incl. in maintenance kit. Contenu dans le jeu d'entretien. Incluido en el juego de mantenimiento. Contenuto nella serie manutenzione.</p> <p>d: Im Dichtungssatz f. 1 Zyl.-K. enth. Incl. in gasket set f. 1 cyl. head. Contenu dans le jeu de joint p. 1 culasse. Incluido en el juego de juntas p. 1 culata. Contenuto nella serie guarnizioni per 1 testa.</p> <p>P: Im Pannensatz enthalten. Incl. in emergency kit. Contenu dans le jeu secur. Incluido en el juego para averias. Contenuto nella serie di prima necessità.</p> <p>D: Im Dichtungssatz Kurbelgeh. Incl. in gasket set crankcase. Contenu dans le jeu de joints carter moteur. Incluido en el juego de juntas caja cigueñal. Contenuto nella serie guarnizioni basamento.</p> <p>1: Anzahl pro Satz - Qty. per kit. Quantite par jeu. Cantidad por juego. Quantità per serie.</p>	
1	00910610	1	1	P1	Dichtungssatz für 1 Zylinderkopf. Gasket set for 1 cyl. head. Jeu de joint p. 1 culasse. Juego de juntas para 1 culata. Serie guarnizioni per 1 testa.
2	01229700	1	1		Dichtungssatz für Kurbelgehäuse. Gasket set for crankcase.
2	01275900	1	1	„LS“	Jeu de joints p. carter moteur. Juego de juntas para caja cigueñal. Serie guarnizioni basamento.
3	00961201	1	1		Wartungssatz für 1000 h. 1000 hours maintenance kit. Kit d'entretien 1000 heures - Juego de piezas para servicio 1000 horas. Kit di manutenzione a 1000 ore.
4	00965603	1	1		Pannensatz - Emergency kit. Kit de secours - Juego para averias Kit di prima necessità.



Achtung!
 Dekompressionshebel nur in Pfeilrichtung ziehen.

Attention!
 Tira decompression-lever in the direction of arrow only.

Attention!
 Tourner levier de decompression seulement en direction de la flèche.

Starten des Motors mit Handkurbel

1. Hebel der Handkurbel nach unten drücken.
2. Startknopf drücken.
3. Bei kaltem Temperaturverhältnis, kaltes Temperaturverhältnis, kaltes Temperaturverhältnis ist kein Öl im Ölwanne ablesen, bis es sich nach dem Start wieder ablesen lässt.
4. Die Ölwanne mit dem Ölwanne nach dem Start ablesen lassen.

Starting of engine with starting handle

1. Release starting handle.
2. Push start button.
3. Push decompression lever in horizontal position.
4. Push decompression lever in horizontal position.

5,6

Demontage des moteurs à la main

1. Laver le moteur de l'huile au moyen de l'huile.
2. Tirer le levier de décompression au démarrage.
3. Tirer le levier de décompression au démarrage.
4. Tirer le levier de décompression au démarrage.

EST 463 0000010

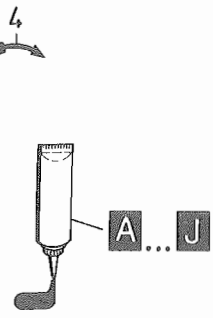
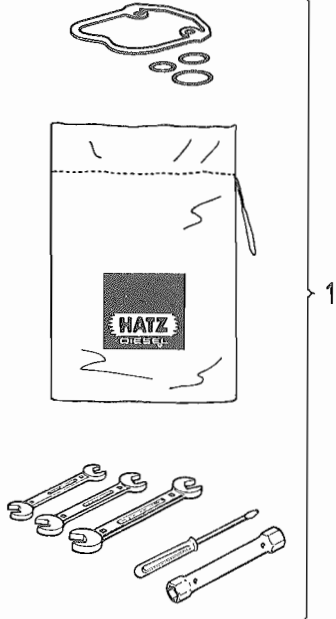
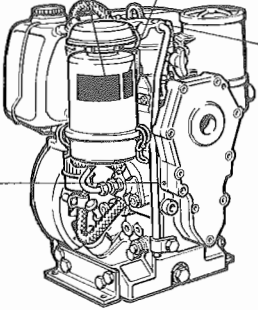

Fig.-No.	HATZ Ident-No.	Stück Qty.	P / W d / D	Bemerkungen Notes
		E 573	E 673	
1	00438400	1	1	Zubehörsatz - Accessoires kit Sort. accessoires Juego de accesorios Serie accessori
2	03631102	1	1	
3	03396301	1	1	
4	03589000	1	1	
5	03325510	1	1	
6	03306810	1	1	LS

Dicht- und Klebstoffe
Sealing- and bonding adhesives
Etanchéifiant et Colle

Materias para empaquetar y pegar
Adesivi e collanti

A = 502 230 01	Loctite Activator N	500 ml	} siehe Hinweis auf den einzelnen Bildtafeln as specified in the individual tables suivant les remarques sur les tableau correspondant según las indicaciones de las tablas correspondientes seguire le indicazioni sul quadro corrispondente
B = 502 231 00	Loctite 573	50 ml	
C = 502 232 00	Loctite 601	50 ml	
D = 502 233 00	Loctite 221	50 ml	
E = 502 234 00	Loctite 648	10 ml	
F = 502 238 00	Technicoll 8058	0,75 kg	
+ 502 239 00	Technicoll 8366	0,75 kg	
G = 502 565 01	Loctite IS 407	20 ml	
H = 502 825 01	Silicon	30 ml	
J = 502 830 01	Hochtemp. Paste	500 g	

M 01

Kurbelgehäuse
Crankcase
Carter moteur
Caja cigueñal
Basamento motore

Tafel Nr.
Tabl. No.
Tavola N.

03

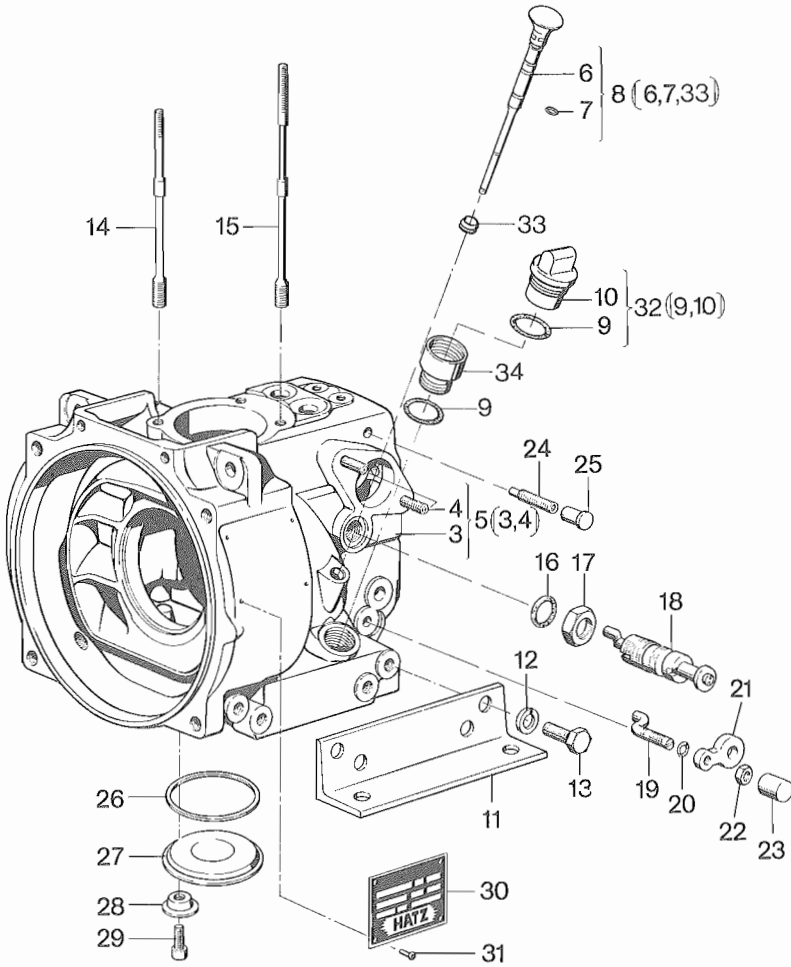

Fig.-No.	HATZ Ident-No.	Stück Qty.	P / W d / D	Bemerkungen Notes
		E 573	E 673	
1	-----	-	-	
2	-----	-	-	
3	-----	-	-	
4	50037300	2	2	M 8 X 18 DIN 835-10.9
5	00912800	1	1	
6	-----	-	-	
7	40022000	2	2	D2 5 X 2
8	00308802	1	1	
9	50153800	2	2	D1 23 X 3
10	-----	-	-	
11	03062100	2	2	
12	50002900	8	8	10 DIN 128
13	50029200	8	8	M 10 X 25 DIN 933-8.8
14	03207701	2	2	
15	03207600	2	2	
16	40022800	1	1	D1 15 X 3,2
17	50024600	1	1	M 20 X 1,5 DIN 936-17H
18	00362400	1	1	
19	03060403	1	1	
20	40021700	1	1	D1 4,47 X 1,78
21	03104901	1	1	
22	50022900	1	1	M 8 DIN 934-8
23	03205800	1	1	
24	50062100	1	1	M 8 X 25 DIN 915 TU. FLEC
25	40039701	1	1	
26	40023800	1	1	D1 74 X 3
27	03205602	1	1	
28	03206200	4	4	
29	50050400	4	4	M 6 X 8 DIN 6912-8.8
30	03225504	1	1	
31	40002500	4	4	2,4 X 6
32	00632101	1	1	W1
33	50324400	1	1	
34	03658400	1	1	

M 01

Drehzahlverstellung
Speed control
Reglage régime
Ajuste de revoluciones
Regolatore di giri

Tafel Nr.
Tabl. No.
Tavola N.

04

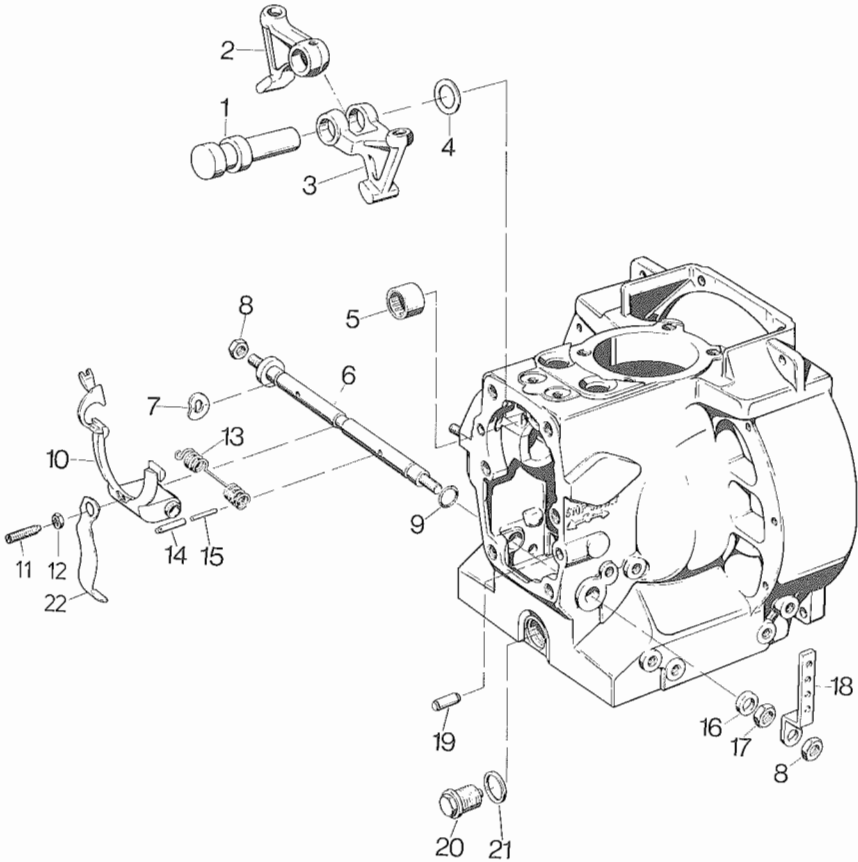

Fig.-No.	HATZ Ident-No.	Stück Qty.	P / W d / D	Bemerkungen Notes
		E 573	E 673	
1	03059700	1	1	
2	03063401	1	1	
3	03063301	1	1	
4	03169800	1	1	0,50 mm
5	40036800	1	1	
6	00427303	1	1	
7	50003600	1	1	B 12 DIN 137
8	50023500	2	2	M 10 DIN 934-8
9	40022300	2	2	D2 8 X 2
10	00308704	1	1	
11	50004200	1	1	M 6 X 20 DIN 915-45 H
12	50144400	1	1	M 6 DIN 934-8 A3C
13	03206500	1	1	2,0 mm Ø ...1800 min ⁻¹
13	04007200	1	1	2,4 mm Ø >1800...2000 min ⁻¹
13	03205704	1	1	2,7 mm Ø >2000 min ⁻¹
13	03444201	1	1	2,6 mm Ø 3000 min ⁻¹ Gen.
14	50034900	2	2	5 X 36 DIN 1481
15	50034300	2	2	3 X 36 DIN 1481
16	03146201	1	1	
17	03206100	1	1	
18	03206000	1	1	
19	03169300	2	2	
19	50058600	1	1	LS 8 M 6 X 50 DIN 7-9 S20K
20	03169103	1	1	W1
21	50001500	1	1	W7,D1 A 21 X 26 DIN 7603-Cu
22	04065500	1	1	Gen.

M 02

Kurbelwelle
Crankshaft
Vilebrequin
Cigüeñal
Albero a gomito

Tafel Nr.
Tabl. No.
Tavola N.

05

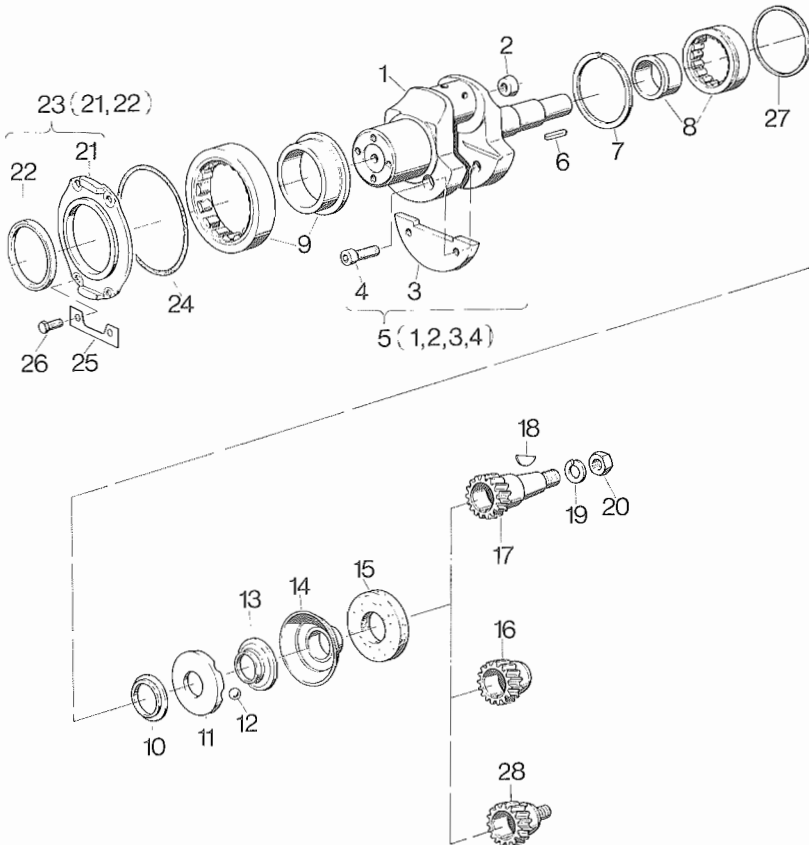
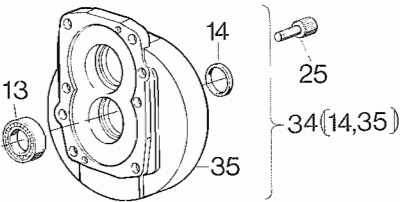
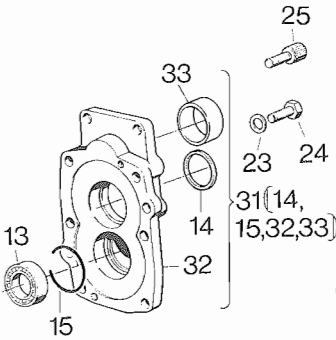
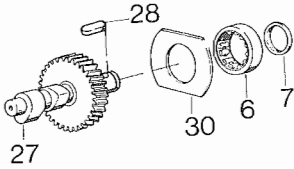
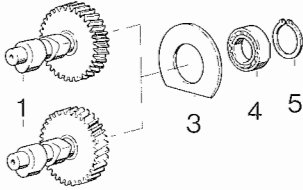

Fig.-No.	HATZ Ident-No.	Stück Qty.	P / W d / D	Bemerkungen Notes
		E 573	E 673	
1	-----	-	-	
2	03195000	1	1	
3	03060901	2	2	
4	50051800	4	4	M 8 X 18 DIN 912-8.8
5	00361202	1	1	
6	50011100	1	1	A 6 X 4 X 28 DIN 6885
7	50036200	1	1	Sp 72 DIN 5417
8	50047700	1	1	
9	50047100	1	1	
10	03206600	1	1	
11	03006602	1	1	
12	50010000	4	4	
13	03170001	1	1	
14	00742000	1	1	
14	01213200	1	1	Gen.
15	03004501	1	1	
16	03064801	1	1	LN/LNF/LS/RN/RNF/LHK/RHK
17	03064901	1	1	LK/LKF/RK/RKF
18	50017900	1	1	6 X 7,5 DIN 6888
19	50003200	1	1	16 DIN 128
20	50024500	1	1	M 16 X 1,5 DIN 936-17 H
21	-----	-	-	
22	40034200	1	1	D1 60 X 75 X 8/9
23	00563001	1	1	
24	50154000	1	1	D1 110 X 3
25	03205901	2	2	
26	50025500	4	4	M 6 X 12 DIN 933-8.8
27	03380400	0...1	0...1	0,10 mm
27	03380500	0...1	0...1	0,20 mm
27	03380600	0...1	0...1	0,30 mm
27	03380700	0...1	0...1	0,40 mm
27	03380800	0...1	0...1	0,50 mm
28	03945800	1	1	LR

M 04

Nockenwelle
Camshaft
Arbre à cames
Arbol de levas
Albero a camme



M 11

Steuerdeckel
Timing cover
Couvercle distr.
Tapa de mando
Coperchio distribuzione

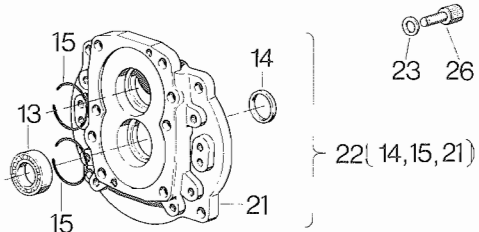
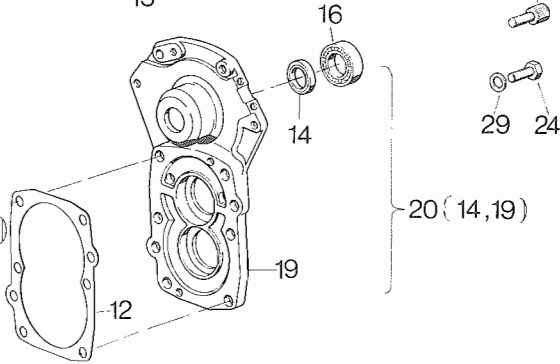
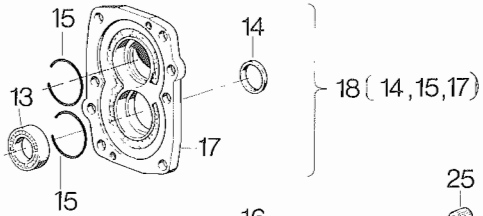
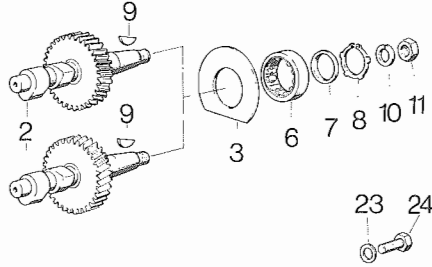

Tafel Nr.
Tabl. No.
Tavola N.

06

Fig.-No.	HATZ Ident-No.	Stück Qty.	P / W d / D	Bemerkungen Notes
		E 573	E 673	
1	03405900	1	1	LK/LKF/LR
1	03405601	1	1	RK/RKF
2	03430000	1	1	LN/LNF/LHK
2	03405800	1	1	RN/RNF/RHK
3	03209300	1	1	
4	50012900	1	1	LK/LKF/RK/RKF/LR
5	50020900	1	1	LR/LKF/RK/RKF 30 X 1,5 X DIN 471
6	50062200	1	1	LN/LNF/RN/RNF/LS/LHK/RHK
7	03278000	1	1	LN/LNF/RN/RNF/LS/LHK/RHK
8	40037900	1	1	LN/LNF/RN/RNF/LHK/RHK
9	50017900	1	1	6 X 7,5 DIN 6888
10	50003200	1	1	16 DIN 128
11	50024500	1	1	M 16 X 1,5 DIN 936-17H
12	03209202	1	1	D1
13	50012900	1	1	
14	40033700	1	1	D1
15	03612400	2	2	30 X 47 X 8
15	03612400	1	1	LK/LN/RK/RN/LKF/LNF/RKF/RNF LHK/RHK
16	50321200	1	1	LS
17	-----	-	-	
18	00362110	1	1	LK/LN/RK/RN
19	-----	-	-	
20	01236800	1	1	LS
21	-----	-	-	
22	00362210	1	1	LKF/LNF/RKF/RNF
23	50001000	5	5	D5
24	50029200	6	6	A 10 X 16 DIN 7603-Cu
24	50029200	2	2	LK/LN/RK/RN M 10 X 25 DIN 933-8.8
24	50029200	4	4	LS M 10 X 25 DIN 933-8.8
24	50029200	4	4	LHK/RHK M 10 X 25 DIN 933-8.8
25	50053800	2	2	LHK/RHK M 10 X 25 DIN 912-8.8
25	50053800	4	4	LS M 10 X 25 DIN 912-8.8
25	50053800	6	6	LR M 10 X 25 DIN 912-8.8
26	50054100	6	6	LKF/LNF/RKF/RNF M10 X 30 DIN 912-8.8
27	03912900	1	1	LS
28	50321400	1	1	6 X 6 X 14 DIN 6885

M 04

Nockenwelle
Camshaft
Arbre à cames
Arbol de levas
Albero a camme

M 11

Steuerdeckel
Timing cover
Couvercle distr.
Tapa de mando
Coperchio distribuzione

Tafel Nr.
Tabl. No.
Tavola N.
06

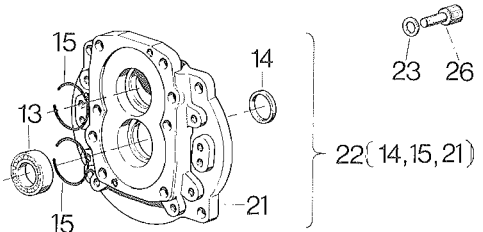
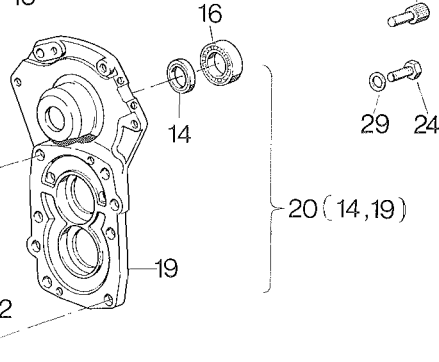
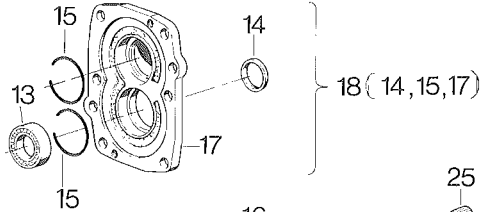
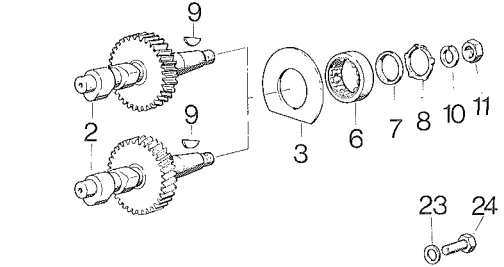
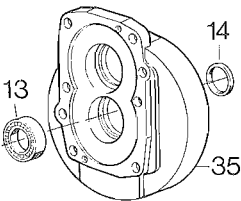
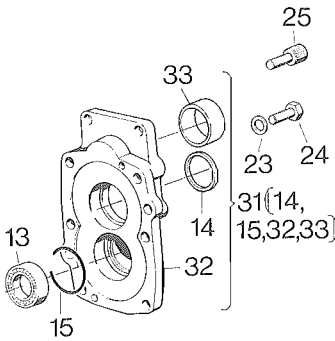
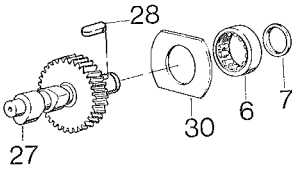
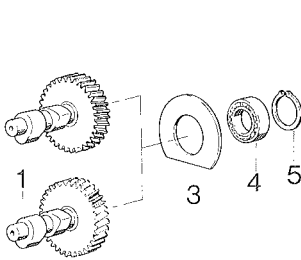

Fig.-No.	HATZ Ident-No.	Stück Qty.	P / W d / D	Bemerkungen Notes	
		E 573	E 673		
29	50001000	4	4	D5	A 10 X 16 DIN 7603-Cu
30	03939800	1	1		LS
31	00362310	1	1		LHK/RHK
32	-----	-	-		
33	40032900	1	1		LHK/RHK
34	01168200	1	1		LR
35	-----	-	-		

M 05

Kolben, Pleuel
Piston, conrod
Piston, bielle
Embolo, biela
Pistone, biella

M 06

Zylinder
Cylinder
Cylindre
Cilindro
Cilindro

Tafel Nr.
Tabl. No.
Tavola N.
07

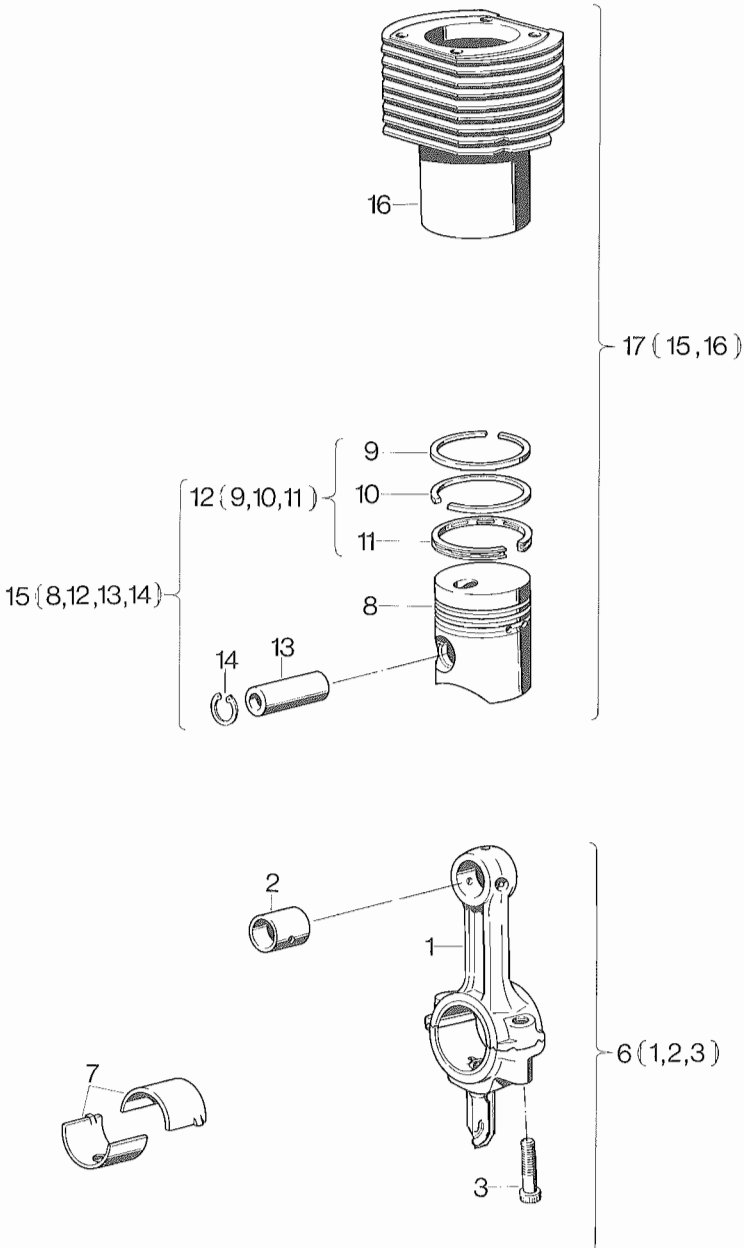

Fig.-No.	HATZ Ident-No.	Stück Qty.	P / W d / D	Bemerkungen Notes
		E 573	E 673	
1	-----	-	-	
2	03206900	1	1	
3	03393700	2	2	
4	-----	-	-	
5	-----	-	-	
6	00361300	1	1	
7	03206700	1	1	
7	03206800	1	1	- 0,5 mm
8	-----	-	-	
9	-----	-	-	
10	-----	-	-	
11	-----	-	-	
12	00904300	1	1	
12	01234000	1	1	+ 0,5 mm
12	00904400	1	1	+ 1,0 mm
13	50107500	1	1	
14	50381200	2	2	A 25 X 1,2 DIN 73130
15	00904101	1	1	
15	01233901	1	1	+ 0,5 mm
15	00909301	1	1	+ 1,0 mm
16	-----	-	-	
17	00912700	1	1	

M 07

Zylinderkopf
Cylinder head
Culasse
Culata
Testa

Tafel Nr.
Tabl. No.
Tavola N.

08

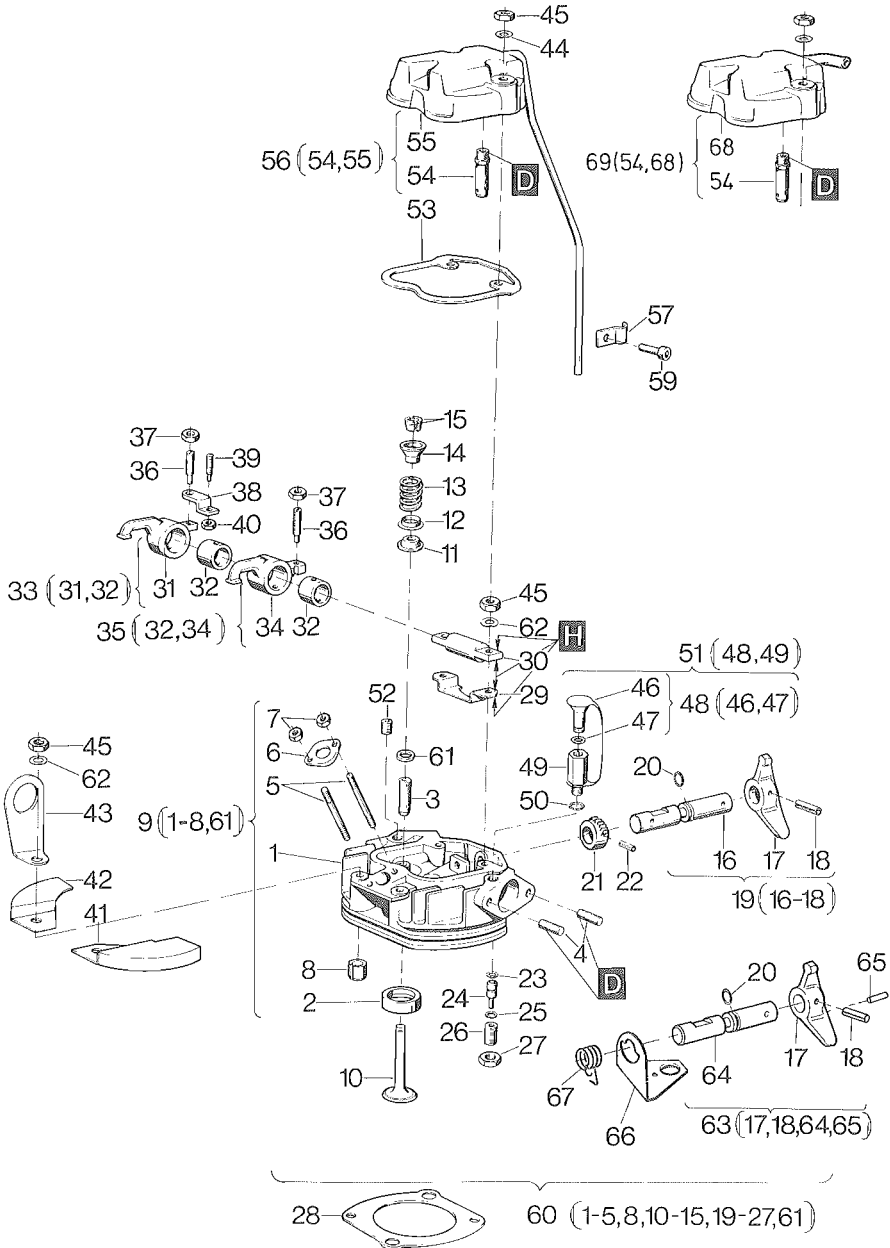

Fig.-No.	HATZ Ident-No.	Stück Qty.	P / W d / D	Bemerkungen Notes
		E 573	E 673	
1	-----	-	-	
2	-----	-	-	
3	03208210	2	2	
4	50037200	4	4	M 8 X 15 DIN 835-10.9
5	50111000	2	2	M 6 X 55 DIN 835-8.8
6	03447300	1	1	
7	50144400	2	2	M 6 DIN 934-8 A3C
8	50035700	2	2	11 X 12 DIN 7346
9	00740121	1	1	
10	03569820	2	2	
11	03208001	2	2	
12	03208400	2	2	
13	03208100	2	2	
14	03060501	2	2	
15	03171910	2	2	
16	-----	-	-	
17	03173401	1	1	
18	50034600	1	1	4 X 18 DIN 1481
19	00746800	1	1	
20	50154300	1	1	d1
21	03570600	1	1	LS/RHK/LHK/LNF/LKF/LN/LK/ RNF/RKF/RN/RK
22	50034100	1	1	3 X 16 DIN 1481
23	50154200	1	1	d1 5 X 1
24	03063800	1	1	
25	50042600	10	10	A 8 DIN 2093
26	03061100	1	1	
27	50023800	1	1	BM10 DIN 439-6
28	03770300	0...1	0...1	0,30 mm
28	03581800	0...1	0...1	d1 0,40 mm
28	03581900	0...1	0...1	0,50 mm
28	03582000	0...1	0...1	d1 0,60 mm
28	03582100	0...1	0...1	0,70 mm
28	03582200	0...1	0...1	0,80 mm
29	03092500	1	1	
30	03061501	1	1	
31	-----	-	-	

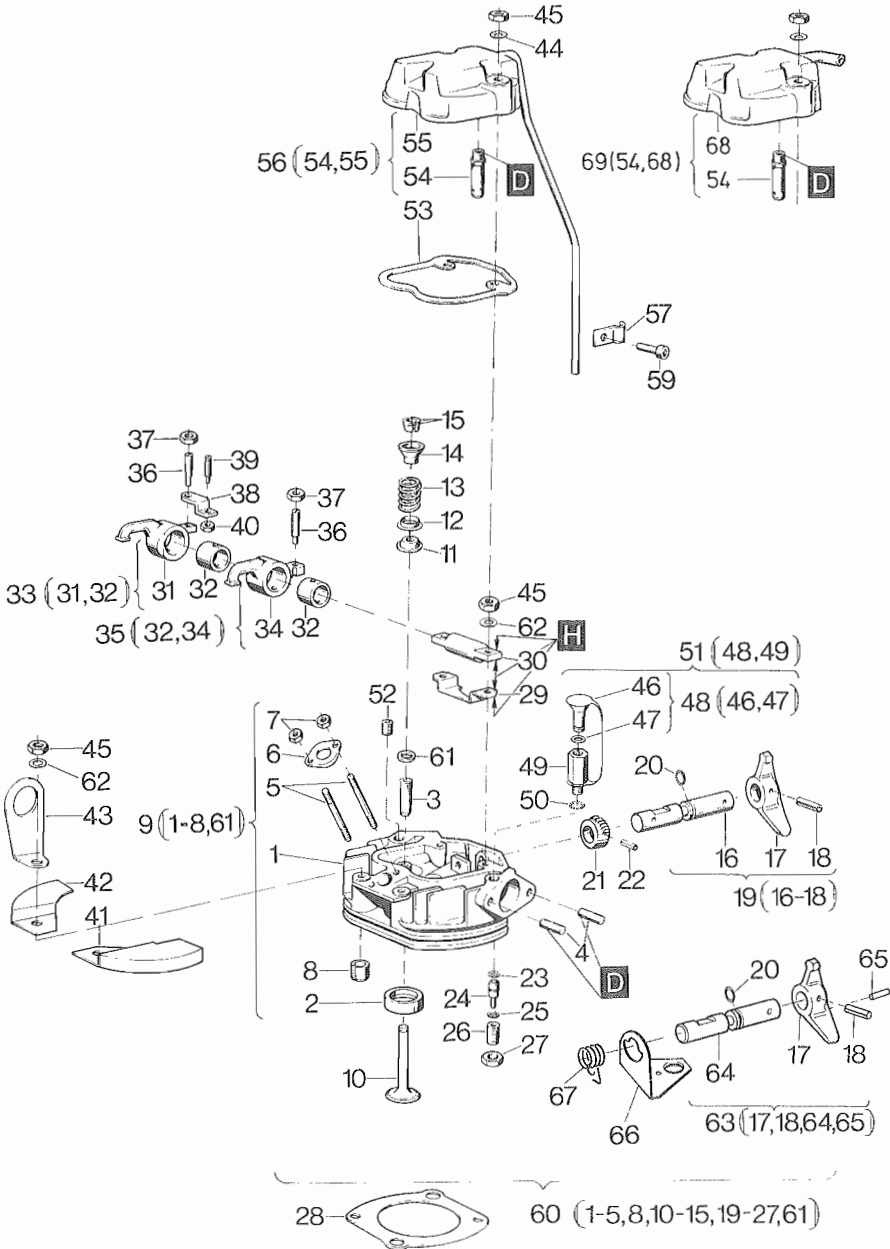

Fig.-No.	HATZ Ident-No.	Stück Qty.	P / W d / D	Bemerkungen Notes
		E 573	E 673	
32	03430100	2	2	
33	00614201	1	1	
34	-----	-	-	
35	00614301	1	1	
36	03003700	2	2	
37	03173100	2	2	W2
38	03060002	1	1	
39	03022001	1	1	
40	50022700	1	1	P2 M 6 DIN 934-8
41	03066401	1	1	
42	03066501	1	1	
43	03457800	1	1	
44	50003500	2	2	W2 B 8 DIN 137
45	50023400	6	6	P4/W2 M 8 X 1 DIN 934-12
46	-----	-	-	
47	40081700	2	2	d2 12 X 2
48	00736300	1	1	P1
49	-----	-	-	
50	50001100	1	1	d1 A 12 X 15,5 DIN 7603-Cu
51	00361801	1	1	
52	50043700	1	1	M 12 X 1,5 DIN 906
53	03208902	1	1	W3,d1
54	00362004	1	1	
55	-----	-	-	
56	00313802	1	1	
57	03091500	1	1	
58	-----	-	-	
59	50051300	1	1	LKF/LNF/RKF/RNF M 8 X 10 DIN 912-8.8
60	00907601	1	1	
61	03753800	2	2	
62	03766300	4	4	P4
63	01168400	1	1	LR
64	-----	-	-	
65	50348600	1	1	LR 3 X 26 DIN 1481
66	03944800	1	1	LR
67	03944700	1	1	LR
68	-----	-	-	
69	01442800	1	1	

M 09

Stoßstange
Pushrod
Tige de culbuteur
Varilla de balancin
Asta bilancieri

M 14

Einspritzausrüstung
Injection equipment
Equipment d'injection
Equipo de inyección
Equipaggiamento iniezione

Tafel Nr.
Tabl. No.
Tavola N.

09

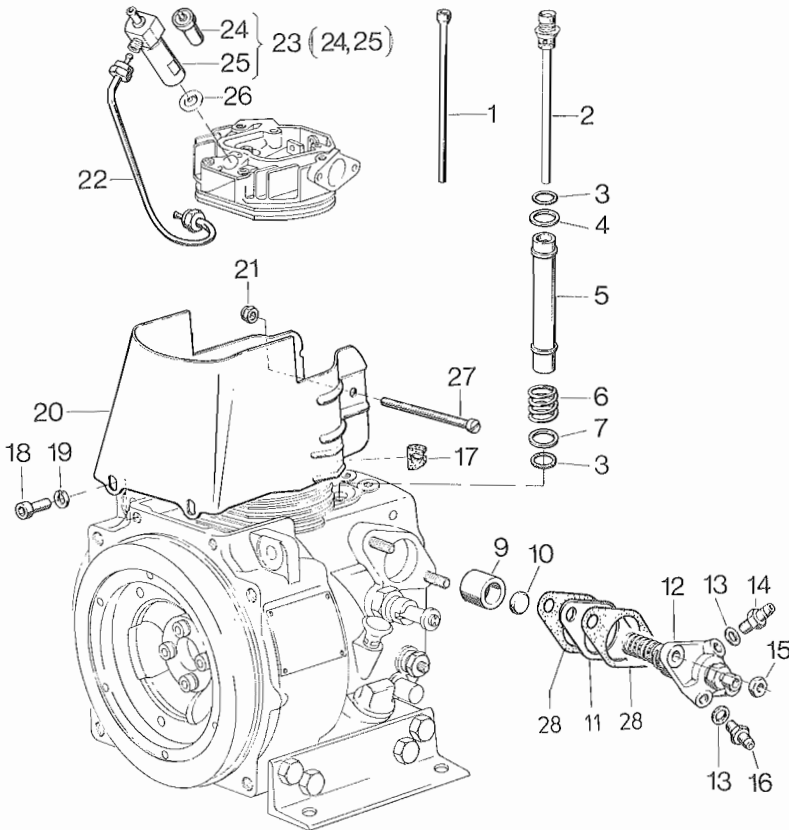

Fig.-No.	HATZ Ident.-No.	Stück Qty.	P / W d / D	Bemerkungen Notes
		E 573	E 673	
1	03063901	1	1	
2	00902600	1	1	
3	50288000	4	4	d4 17 X 3
4	03209101	2	2	
5	03209002	2	2	
6	03185100	2	2	
7	03209101	2	2	
8	-----	-	-	
9	03064000	1	1	
10	03062600	1	1	
11	03209400	0...1	0...1	0,10 mm
11	03209500	0...1	0...1	0,15 mm
11	03209600	0...1	0...1	0,20 mm
11	03209700	0...1	0...1	0,30 mm
11	03209800	0...1	0...1	0,50 mm
12	40080201	1	1	
13	50001100	2	2	D2
14	00671001	1	1	
15	50022900	2	2	M 8 DIN 934-8
16	03485000	1	1	
17	03150900	1	1	
18	50051600	2	2	M 8 X 16 DIN 912-8.8
19	50148100	2	2	8,4 DIN 125 St A3C
20	03066601	1	1	
21	40028200	1	1	M 5 SSN 440-8 Cu
22	03405700	1	1	
23	40006600	1	1	
24	40004600	1	1	P1
25	-----	-	-	
26	40003100	1	1	P1
27	50064600	1	1	M 5 X 80 DIN 84-4.8
28	04071300	2	2	D2

Andrehvorrichtung
Starting device

M 15

Dispositiv demarrage
Dispositivo de arranque
Dispositivo di avviamento

Schwungrad
Flywheel

M 17

Volant
Volante
Volano

Tafel Nr.
Tabl. No.
Tavola N.

10

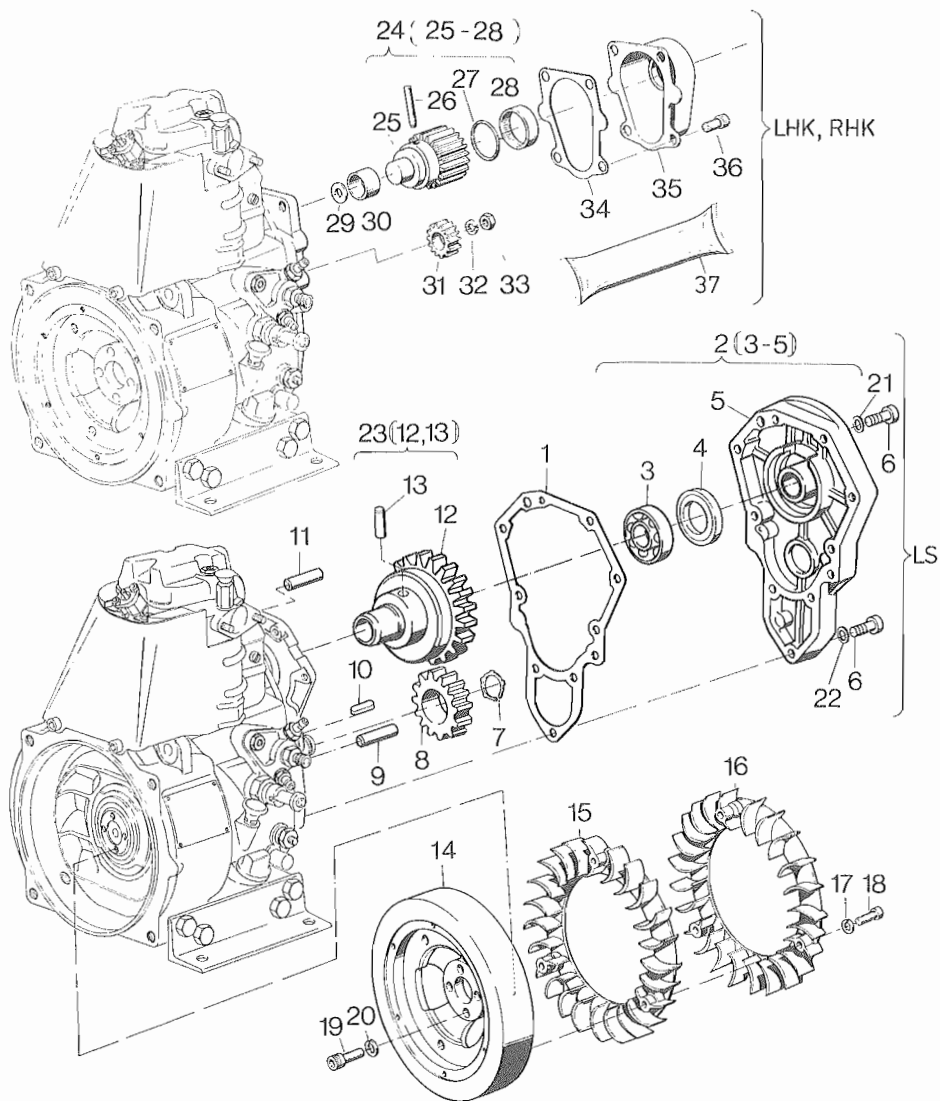

Fig.-No.	HATZ Ident.-No.	Stück Qty.	P / W d / D	Bemerkungen Notes
		E 573	E 673	
1	03913100	1	1	
2	01231800	1	1	
3	50321300	1	1	
4	40033900	1	1	40 X 52 X 7
5	-----	-	-	
6	50051100	9	9	M 6 X 30 DIN 6912-8.8
7	50324800	1	1	AL 22 X 1,2
8	03912600	1	1	
9	50058600	1	1	8 M 6 X 50 DIN 7-9 S20K
10	50321400	1	1	A 6 X 6 X 14 DIN 6885
11	50349200	1	1	8 m 6 X 32 DIN 6325
12	-----	-	-	
13	03262000	1	1	
14	03063201	1	1	
15	00635000	1	1	LK/LKF/LN/LNF/LS/LHK
16	00946800	1	1	RK/RKF/RN/RNF/RHK
17	40027800	6	6	
18	40035600	6	6	
19	50054500	4	4	M 10 X 35 DIN 912-10.9
20	50002900	4	4	10 DIN 128
21	50081200	6	6	A 6 DIN 137 A3C
22	50000800	3	3	A 6,5 X 9,5 DIN 7603-Cu
23	01166300	1	1	LS
24	00410611	1	1	LHK/RHK
25	-----	-	-	
26	03262000	1	1	
27	50252400	1	1	D1
28	40019000	1	1	
29	40001300	1	1	
30	40032900	1	1	
31	03112410	1	1	
32	50003200	1	1	16 DIN 128
33	50024500	1	1	M 16 X 1,5 DIN 936-17H
34	03210000	1	1	D1
35	00313701	1	1	
36	50053400	4	4	M 10 X 16 DIN 912-8.8
37	50342600	1	1	LHK/RHK 100 g

M15

Reversierstarter
Recoil starter
Demarreur reversible
Arrancador reversible
Avviamento a strappo

Tafel Nr.
Tabl. No.
Tavola N.

11

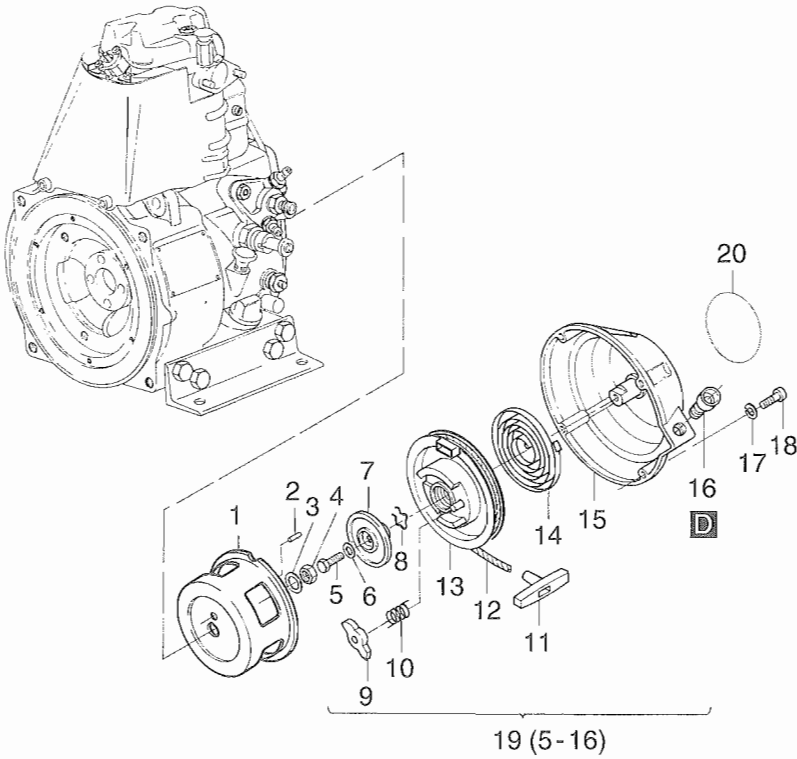

Fig.-No.	HATZ Ident-No.	Stück Qty.	P / W d / D	Bemerkungen Notes
		E 573 LR	E 673 LR	
1	01166700	1	1	
2	50348900	1	1	4 m 6 X 6 DIN 7
3	50348800	1	1	12 DIN 6796 FST
4	50063500	1	1	M 12 DIN 936-17 H A3C
5	50146300	1	1	M 6 X 18 DIN 933-8.8 A3C
6	50165600	1	1	6,5 X 14 DIN 6904 A3C
7	50348300	1	1	
8	50348100	1	1	
9	50347900	1	1	
10	50348200	1	1	
11	50348500	1	1	
12	50348400	1	1	
13	50347800	1	1	
14	50348000	1	1	
15	03944601	1	1	
16	03946800	1	1	
17	50081200	4	4	A 6 DIN 137
18	50170600	4	4	M 6 X 20 DIN 912-8.8 A3C
19	01172701	1	1	
20	03947000	1	1	Hinweisschild, sticker label, plaque, placa

Kraftstoffbehälter
Fuel tank
A 01 Reservoir à carburant
Depósito combustible
Serbatoio e circuito combustibile

Tafel Nr.
Tabl. No.
Tavola N.

12

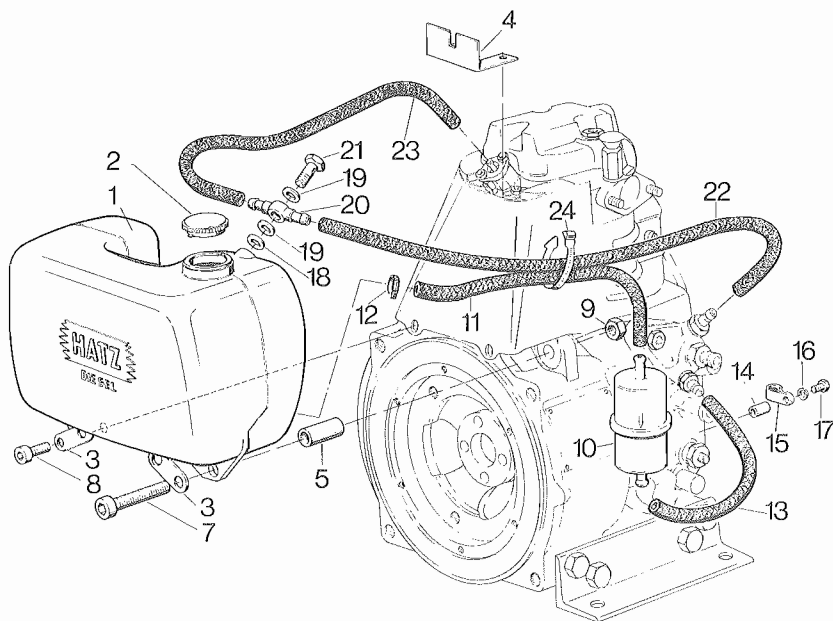

Fig.-No.	HATZ Ident-No.	Stück Qty.		P / W d / D	Bemerkungen Notes
		E 573	E 673		
1	00691300	1	1		140 mm
1	01139400	1	1		„LS“ 120 mm
2	40032611	1	1	P1	
3	03525800	4	4		
4	03492900	1	1		
5	03493000	2	2		9 X 16 X 31
6	-----	-	-		
7	50171600	2	2		M 8 X 65 DIN 912-8.8 A3C
8	50171500	2	2		M 8 X 25 DIN 912-8.8 A3C
9	40028400	2	2		VM 8 DIN 980-8 C3A
10	40089401	1	1	W2	
11	03493100	1	1		7 X 2,5 - 60 mm
12	40037300	1	1		
13	03493500	1	1		7 X 2,5 - 200 mm
14	03042700	1	1		7 X 12 X 20
15	03165500	1	1		
16	50165600	1	1		6,5 X 14 DIN 6904-A3C
17	50168700	1	1		M 6 X 35 DIN 931-8.8 A3C
18	50158300	1	1		10,5 DIN 125-Cu
19	50062400	2	2	D2	A 10 X 13,5 DIN 7603-Cu
20	40093300	1	1		
21	50169700	1	1		C 4 DIN 7623-Zn
22	03493600	1	1		7 X 2,5 - 330 mm
23	03493300	1	1		7 X 2,5 - 140 mm
24	40092700	1	1		

Fig.-No.	HATZ Ident-No.	Stück Qty.	P / W d / D	Bemerkungen Notes
		E 573	E 673	
1	01154400	1	1	LS
2	40099400	1	1	
3	-----	-	-	
4	49037500	1	1	P1
5	49037600	1	1	
6	50208500	2	2	8 DIN 128-A3C
7	50023000	2	2	M 8 Ms DIN 934-Ms
8	40053500	1	1	
9	40071500	1	1	
10	40101000	1	1	
11	00864900	1	1	
12	01286100	1	1	d1
13	40081600	2	2	M 8 Ms
14	00785200	1	1	
15	50016800	6	6	8,4 Ms DIN 125-Ms
16	50173100	4	4	M 8 X 10 DIN 912-8.8 A3C
17	03699700	1	1	
18	03829000	1	1	R 1 1/4
19	00872200	1	1	R 1 1/4
20	50037800	2	2	M 8 X 22 DIN 835-10.9
21	03324500	1	1	
22	40099600	1	1	
23	01284600	1	1	W1,d1
24	40099500	1	1	P1
25	03933001	1	1	LS
26	50333500	2	2	M 6 X 8 DIN 933-8.8 A3C
27	50144500	2	2	6,4 DIN 125-St A3C
28	03940100	1	1	LS f. Taf., Tabl. 15, Pos. 1-20
29	05003400	1	1	Taf., Tabl. 08, Pos. 69
30	05003300	1	1	200 mm

A 04

Andrehkurbel, Startscheibe
Starting handle, starter pulley
Manivelle, poulie lancement
Manivela, polier de arranque
Manovella, puleggia avviamento

Tafel Nr.
Tabl. No.
Tavola N.

14

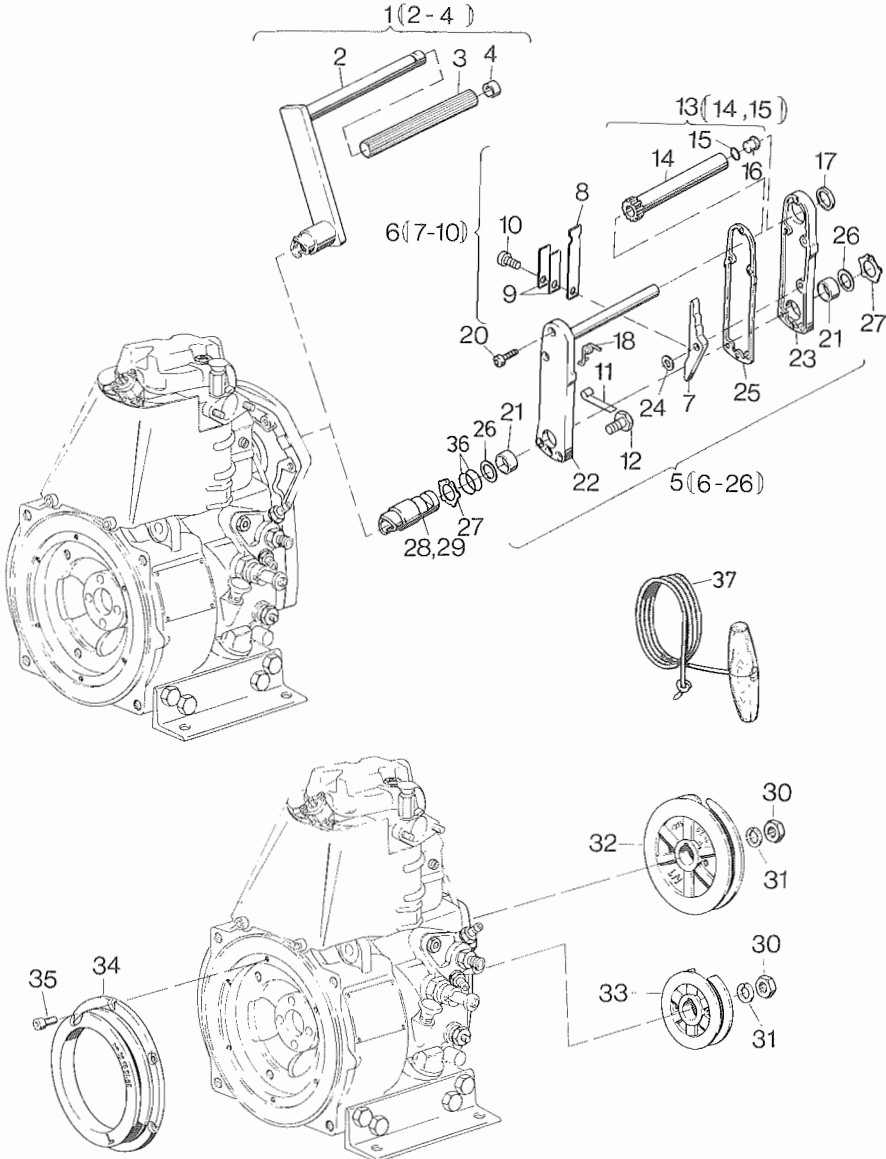

Fig.-No.	HATZ Ident-No.	Stück Qty.	P / W d / D	Bemerkungen Notes
		E 573	E 673	
1	00315000	1	1	LHK
1	00424100	1	1	RHK
1	01140001	1	1	LS
2	-----	-	-	
3	03522400	1	1	
4	03515400	1	1	
5	01027905	1	1	"B"
5	01027805	1	1	"A"
6	01011404	1	1	
7	-----	-	-	
8	03812102	1	1	
9	03917100	2	2	
10	50316500	2	2	M 5 X 8 DIN 6912-8.8 A3C
11	03954900	1	1	
12	03955600	1	1	
13	01011310	1	1	
14	-----	-	-	
15	50169100	1	1	19 X 1,8
16	50199200	1	1	
17	50194200	1	1	
18	03955900	1	1	"A"
18	03956000	1	1	"B"
19	-----	-	-	
20	50194400	5	5	M 6 X 25 A3C
21	50193400	2	2	
22	-----	-	-	
23	-----	-	-	
24	50195800	1	1	10 X 16 X 0,5 DIN 988
25	03813000	1	1	
26	03928600	2...4	2...4	30 X 38 X 0,15
27	50194300	2	2	AK 30 X 1,5
28	01018600	1	1	LHK 50 mm
28	01157801	1	1	LS 80 mm
28	01139902	1	1	LS 60 mm
28	01018800	1	1	LHK 108 mm
28	01047500	1	1	LHK 177 mm

A 04

Andrehkurbel, Startscheibe
Starting handle, starter pulley
Manivelle, poulie lancement
Manivela, polier de arranque
Manovella, puleggia avviamento

Tafel Nr.
Tabl. No.
Tavola N.

14

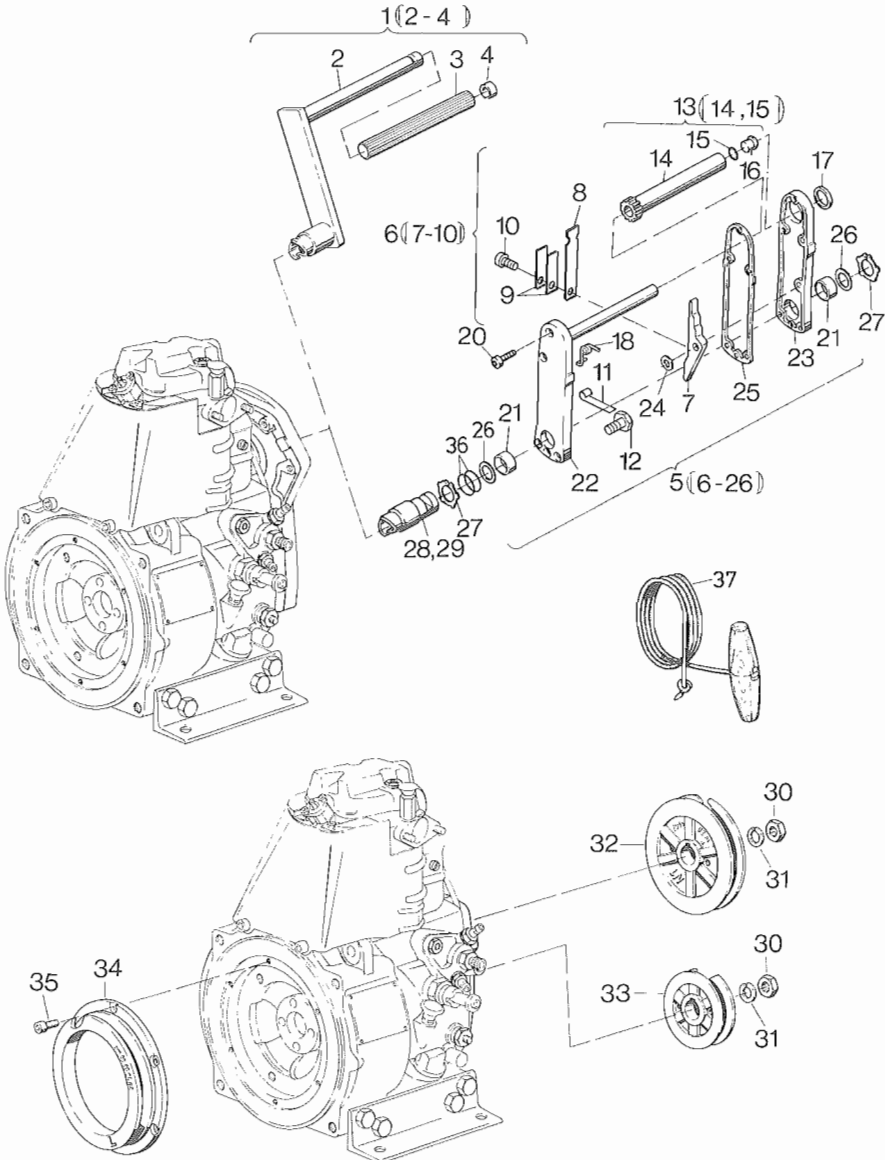

Fig.-No.	HATZ Ident-No.	Stück Qty.	P / W d / D	Bemerkungen Notes
		E 573	E 673	
29	01018700	1	1	RHK 50 mm
30	50024500	1	1	M 16 X 1,5 DIN 936-17 H
31	50003200	1	1	16 DIN 128
32	03091902	1	1	LN
32	03090102	1	1	RN
33	03090202	1	1	LK
33	03090002	1	1	RK
34	03078802	1	1	LK/LKF/LN/LNF
34	03078902	1	1	RK/RKF/RN/RNF
35	50050700	6	6	M 6 X 16 DIN 912-8.8
36	50258500	2	2	26 X 1,5
37	00409400	1	1	

A 09

Drehzahlverstellung
Speed control
Reglage régime
Ajuste de revoluciones
Comando acceleratore

A 16

Wellenstummel, Zentrierflansch
Stubshaft, cent. flange flyw. side
Bout de arbre, bride centr. c. vol.
Eje, brida de centraje
Contralbero, centraggio

Tafel Nr.
Tabl. No.
Tavola N.

15

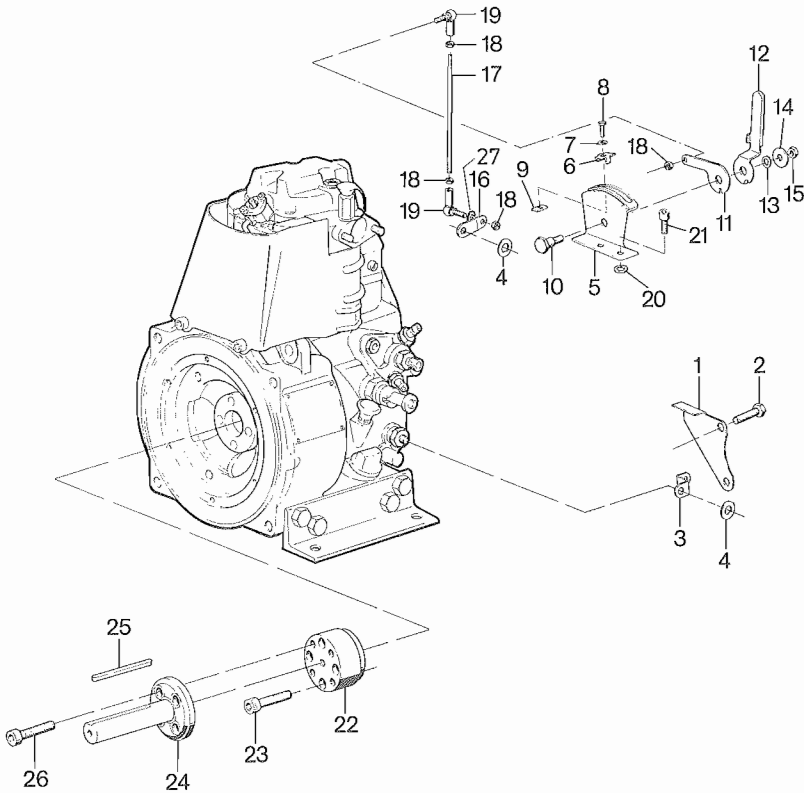

Fig.-No.	HATZ Ident-No.	Stück Qty.	P / W d / D	Bemerkungen Notes
		E 573	E 673	
1	03108200	1	1	LKF/LNF/RKF/RNF L/LK/LN/R/RK/RN
2	50029300	2	2	M 10 X 30 DIN 933-8.8
3	03108100	1	1	
4	03105600	1	1	
5	00720400	1	1	
5	01145800	1	1	LS
6	03112200	2	2	
7	50216300	2	2	5,3 DIN 125-St A3C
8	50025100	2	2	M 5 X 10 DIN 933-8.8
9	03112101	2	2	
10	03511700	1	1	
11	03511600	1	1	
11	03928700	1	1	LS
12	03511500	1	1	
12	03927600	1	1	LS
13	50003500	1	1	B 8 DIN 137
14	50062900	1	1	B 8,4 DIN 9021-St-A3C
15	50023200	2	2	BM 8 DIN 439-5
16	03511900	1	1	
17	03511000	1	1	
17	03928800	1	1	LS
18	50144400	4	4	M 6 DIN 934-8 A3C
19	50133300	2	2	
20	50123000	2	2	8,4 DIN 7349
21	50051900	2	2	M 8 X 20 DIN 912-8.8
22	03094700	1	1	
23	50054800	4	4	M 10 X 45 DIN 912-10.9
24	03027300	1	1	
25	50011700	1	1	A 8 X 7 X 63 DIN 6885
26	50053800	4	4	M 10 X 25 DIN 912-8.8
27	50144500	0...1	0...1	"LR" 6,4 DIN 125-St A3C

Anhang für nicht abgebildete Zusatzausrüstung:

Weitere Zusatzausrüstungen können aus Platzgründen in der Ersatzteilliste nicht mehr detailliert dargestellt werden. Für die Bestellung von Teilen aus nicht abgebildeten Zusatzausrüstungen verwenden Sie bitte nachfolgende Übersicht. Anhand der Skizze ist die gesuchte Zusatzausrüstung auffindbar, die für den jeweiligen Motortyp zugehörige Ident-Nr. der Ausrüstung ist aus der Tabelle ersichtlich.

Ihre zuständige HATZ-Vertretung kann Ihnen anhand dieser Ident-Nr. das gewünschte Ersatzteil heraussuchen.

Annex for additional equipment which is not illustrated:

Due to lack of space we cannot list further additional equipment in our parts list: For parts ordering not illustrated, please use the below listed survey. With the aid of sketches you can find the required additional equipment. The ident-number belonging to the corresponding engine type can be taken from the table.

Your HATZ agent is in a position to select for you the required spare part as soon as you have selected the correct ident-number.

Annexe concernant es accessoires complémentaires non-illustrés:

Un certain nombre d'accessoires complémentaires n'ont pu, par suite d'un manque de place, être représentés d'une manière détaillée dans la liste de pièces détachées.

Pour la commande de ces accessoires, qui ne sont pas illustrés, veuillez utiliser l'aperçu ci-après. A l'aide des croquis, il est possible de trouver l'accessoire souhaité, le No. ident. correspondant pour chaque type de moteur figure dans le tableau.

Grâce à ce No. ident. votre représentant HATZ pourra vous trouver la pièce souhaitée.

En relación a equipos adicionales no ilustrados:

Debido a razones de espacio no es posible ilustrar otros equipos adicionales en la lista de piezas. Para pedidos de equipos adicionales no ilustrados favor usen la siguiente orientación. A base de las ilustraciones es posible encontrar el equipo adicional buscado, el número ident para el tipo de motor para el cual se necesita el equipo se puede obtener de la tabla.





El representante HATZ para su area puede entonces a base del número ident encontrar las piezas deseadas.

Allegato concernente gli accessori complementari non illustrati:

Un certo numero di accessori complementari non sono stati inseriti in modo dettagliato sul catalogo ricambi per mancanza di spazio. Per effettuare un ordine di questi accessori vogliate utilizzare le tavole che seguono. Con l'aiuto dei disegni è possibile trovare il pezzo desiderato, ed il codice corrispondente per ogni tipo di motore.

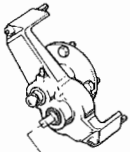
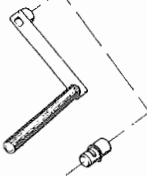

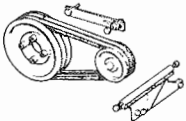
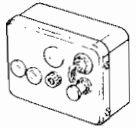

Con il codice del pezzo il vostro concessionario HATZ potrà soddisfare la vostra richiesta.

Zusatzausrüstungen
Equipements
Accessoires complémentaires
Accessori complementari
Equipos



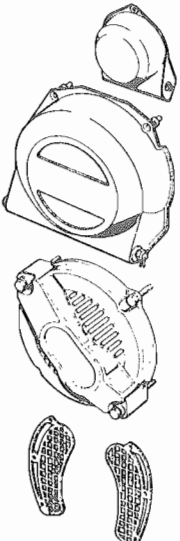

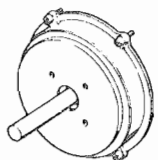
	Code	Ident-No.	E 573	E 673	Bemerkungen Notes
	A 04.70	00584301	L	L	
	A 04.70	00584401	R	R	
	A 04.70	01044400	X	X	
	A 04.70	01018002	L	L	
	A 04.70	01044300	R	R	
	A 05.20	00475202	R	L/R	
	A 05.20	00475002	RK	L/RK	
	A 05.30	00475101	L/R	L	
	A 05.30	00474601	LK/RK	LK/RK	
	A 05.60	00779501	X	X	
	A 05.60	00716102	X	X	
	A 08.10	00406300	X	X	

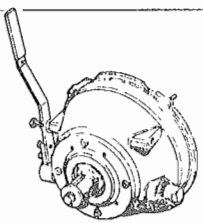
Zusatzrüstungen
 Equipements
 Accessoires complémentaires
 Accessori complementari
 Equipos

Bemerkungen
 Notes

	Code	Ident-No.	E 573	E 673	
	A 12.20	00624500	X	X	
	A 12.20	00624700	X	X	
	A 12.20	00624600	X	X	
	A 12.20	00728000	X	X	
	A 12.20	00868100	X	X	
	<hr/>				
	A 16.20	00474100	X	X	
	A 16.20	00682400	X	X	
	A 15.20	01131700	X	X	
	A 16.20	01132100	X	X	
	A 15.20	01132200	X	X	
	A 16.20	01132100	X	X	
	A 16.30	00474000	X	X	
	A 16.30	00474400	X	X	
	A 17.11	00475800	X	X	

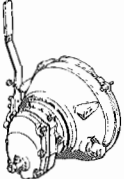
Zusatzausrüstungen
Equipements
Accessoires complémentaires
Accessori complementari
Equipos

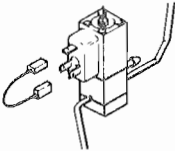
	Code	Ident-No.	E 573	E 673	Bemerkungen Notes
	A 17.30	00404800	X	X	
	A 17.30	00404900	X	X	
	A 17.50	00486400	X	X	
	A 17.50	00486500	X	X	
	A 20.10	00480301	X	X	i = 1,8
	A 21.10	00485500	X	X	i = 10,4
	A 21.10	00496601	LKF, LNF RKF, RNF	LKF, LNF RKF, RNF	i = 6,6
	A 21.10	00496401	LKF, LNF RKF, RNF	LKF, LNF RKF, RNF	i = 10,4
	A 11.10	01086500	X	X	12 V
	A 11.10	01182200	X	X	

Serien-Nr.-Änderungen
Serial-code modification list
Modification des Nos de serien
Modificación de los Nos de serie
Modifica dei codici

Bildtafel	Pos. No.	Bestell-Nr.	Stück	Bildtafel	Pos. No.	Bestell-Nr.	Stück	
Table	Fig. No.	Ordering No.	Qty.	Table	Fig. No.	Ordering No.	Qty.	IMT
Planche	Fig. No.	No. référence	Qté.	Planche	Fig. No.	No. référence	Qté.	No.
Tabla	Fig. No.	No. de pedido	Cant.	Tabla	Fig. No.	No. de pedido	Cant.	
Tavola	Rif.	Codice	Q.tà	Tavola	Rif.	Codice	Q.tà	

E 573.10

E 573.11

E 673.10

E 673.11

83.413

06	3	03208200	2	≠	08	3	03208210	2
06	9	00740120	1	=	08	9	00740121	1
06	10	03569810	2	≠	08	10	03569820	2
06	15	03208301	2	≠	08	15	03171910	2
06	61	- - - - -	-		08	61	03753800	2