

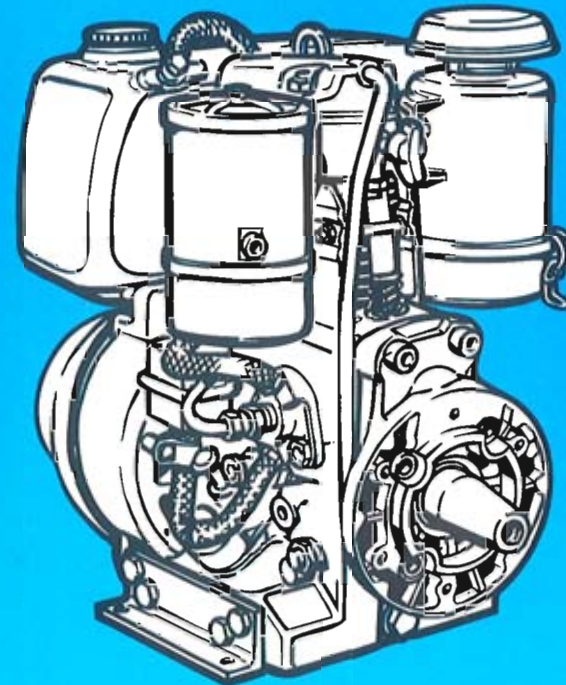

MOTORENFABRIK HATZ • D-94099 Ruhstorf • Germany  
Tel.: 0 85 31 / 319-0 • Telex: 57260 • Telefax: 0 85 31 / 31 94 18

**Original-Ersatzteile**  
Original-spare parts  
Pièces de rechange d'origine  
Repuestos originales  
Pezzi di ricambio originali



434 000 01 -05.96 - 5  
Printed in Germany

DM 3.-

E 573 ...  
E 673 ...

# Bestellung für HATZ-Original-Ersatzteile

Order for HATZ Original spare parts

Commande de pièces d'origine HATZ

Pedido de repuestos originales HATZ

Ordine parti di ricambio originali HATZ

Besteller / Customer / Client / Cliente / Cliente

TYP

MOTOR/FABRIK NO.

MIN-1



Ersatzteilliste Nr./ Spare parts list no./ Liste des pièces de rechange no./ Lista de repuestos No./ Lista ricambi n.

**E 573 . 11**

**E 673 . 11**

Stück / Qty / Q.tà	HATZ Ident No.	Stück / Qty / Q.tà	HATZ Ident No.

Versandart / Mode of dispatch / Mode d'expédition / Despacho deseado / Modo di spedizione

Post / Surface / Poste / Correo / Posta  Luftfracht / airfreight / frêt aérien / Ilete aereo / Via aerea   
Express / express / exprès / expreso / Espresso  .....

Versandadresse / Consignee / Adresse destination / Dirección / Indirizzo di destinazione

Bestellung an: Order at: Commande à: Pedido a:

- die nächste HATZ-Servicestelle (siehe Servicestellenverzeichnis)
- your nearest HATZ service station (see service-list)
- votre station-service HATZ la plus proche (voir liste "Service")
- al servicio HATZ más cercano (ver cuaderno de Servicio)
- al più vicino centro di servizio HATZ (vedi lista centri autorizzati)

**MOTORENFABRIK HATZ**  
**D-94099 RUHSTORF**

Tel: 0 85 31 / 319 - 0

Fax: 0 85 31 / 31 94 21

<b>Inhaltsverzeichnis</b>		<b>Index</b>	Tafel-Nr. Table No.
<b>M ..</b>	<b>Grundmotor</b>	<b>Basic engine</b>	
00	Ersatzteilsätze,	Spare parts kits,	01
34	Zubehör, Schilder	accessories, labels	02
01	Kurbelgehäuse	Crankcase	03
01	Drehzahlverstellung	Speed control	04
02,	Kurbelwelle	Crankshaft	05
04, 11	Nockenwelle, Steuerdeckel	Camshaft, timing cover	06
05, 06	Kolben, Pleuel, Zylinder	Piston, conrod, cylinder	07
07	Zylinderkopf	Cylinder head	08
09, 14	Stoßstange, Einspritzausrüstung	Pushrod, injection equipment	09
15, 17	Andrehvorrichtung, Schwungrad	Starting device, flywheel	10
15	Reversierstarter	Recoil starter	11
<b>A ..</b>	<b>Zusatzausrüstung</b>	<b>Equipements</b>	
01	Kraftstoffbehälter	Fuel tank	12
02, 03	Luftfilter, Auspufftopf	Air filter, exhaust silencer	13
04	Andrehkurbel, Startscheibe	Starting handle, starter pulley	14
09, 16	Drehzahlverstellung einstellbar, Wellenstummel, Zentrierflansch	Speed control, stubshaft, cent. flange flyw. side	15
			Seite/Page
	Zusatzausrüstungen	Equipements	42 – 45
	Serien-Nr.-Änderungen	Serial-code modification list	46

**Sommaire**

**Indice**

<b>M ..</b>	<b>Moteur de base</b>	<b>Motor de base</b>	
00	Jeu de pièces de rechange,	Juegos de recambios,	01
34	accessoires, plaques	accessorios, placas	02
01	Carter moteur	Caja cigueñal	03
01	Reglage régime	Ajuste de revoluciones	04
02	Vilebrequin	Cigüeñal	05
04, 11	Arbre à cames, couvercle distribution	Arbol de levas, tapa de mando	06
05, 06	Piston, bielle, cylindre	Embolo, biela, cilindro	07
07	Culasse	Culata	08
09, 14	Tige de culbuteur, Equipement d'injection	Varilla de balancín, Equipo de inyección	09
15, 17	Dispositif démarrage, volant	Dispositivo de arranque, volante	10
15	Demarreur reversible	Arrancador reversible	11

<b>A ..</b>	<b>Accessoires</b>	<b>Equipos</b>	
01	Reservoir à carburant	Depósito combustible	12
02, 03	Filtre à air, silencieux	Filtro de aire, silenciador	13
04	Manivelle, poulie lancement	Manivela, polier de arranque	14
09, 16	Reglage régime, bout de arbre, bride centr. c. vol.	Ajuste de velocidad. eje, brida de centraje	15

Page/Página No.

Aperçu de modifications	Tabla de modificaciones	42 – 45
Modification des Nos de serien	Modificación de los Nos de serie	46

<b>M ..</b>	<b>Motore di base</b>	
00	Serie guarnizioni	01
34	kit accessori	02
01	Basamento motore	03
01	Regolatore di giri	04
02	Albero a gomito	05
04, 11	Albero a camme coperchio distribuzione	06
05, 06	Pistone, biella, cilindro	07
07	Testa	08
09, 14	Asta bilancieri, Equipaggiamento di iniezione	09
15, 17	Dispositivo di avviamento, volano	10
15	Avviamento a strappo	11
<b>A ..</b>	<b>Accessori</b>	
01	Serbatoio e circuito combustibile	12
02, 03	Filtro aria, marmitta	13
04	Manovella, puleggia per avviamento	14
09, 16	Comando acceleratore, contralbero, flangia di centraggio	15
		Pagina
	Predisposizioni	42 – 45
	Modifica dei codici	46



**M00**

Ersatzteilsätze  
Spare parts kits  
Jeux de pièces de rechange  
Juegos de piezas de recambios  
Serie guarnizioni

Tafel Nr.  
Tabl.No.  
Tavola N.

**01**

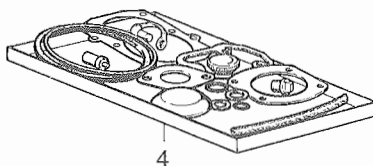
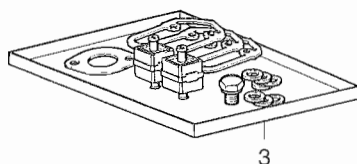
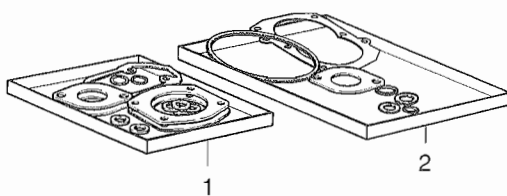

Fig.-No.	HATZ Ident-No.	Stück Qty.	P / W d / D	Bemerkungen Notes	
E 573 E 673					
W:		Im Wartungssatz enthalten. Incl. in maintenance kit. Contenu dans le jeu d'entretien. Incluido en el juego de mantenimiento. Contenuto nella serie manutenzione.		P:	Im Pannensatz enthalten. Incl. in emergency kit. Contenu dans le jeu secur. Incluido en el juego para averias. Contenuto nella serie di prima necessità.
d:		Im Dichtungssatz f. 1 Zyl.-K. enth. Incl. in gasket set f. 1 cyl. head. Contenu dans le jeu de joint p. 1 culasse. Incluido en el juego de juntas p. 1 culata. Contenuto nella serie guarnizioni per 1 testa.		D:	Im Dichtungssatz Kurbelgeh. Incl. in gasket set crankcase. Contenu dans le jeu de joints carter moteur. Incluido en el juego de juntas caja cigueñal. Contenuto nella serie guarnizioni basamento.
				1:	Anzahl pro Satz - Qty. per kit. Quantite par jeu. Cantidad por juego. Quantità per serie.
1	00910610	1	1	P1	Dichtungssatz für 1 Zylinderkopf. Gasket set for 1 cyl. head. Jeu de joint p. 1 culasse. Juego de juntas para 1 culata. Serie guarnizioni per 1 testa.
2	01229700	1	1	„LS“	Dichtungssatz für Kurbelgehäuse. Gasket set for crankcase. Jeu de joints p. carter moteur. Juego de juntas para caja cigueñal. Serie guarnizioni basamento.
2	01275900	1	1		
3	00961201	1	1		Wartungssatz für 1000 h. 1000 hours maintenance kit. Kit d'entretien 1000 heures - Juego de piezas para servicio 1000 horas. Kit di manutenzione a 1000 ore.
4	00965603	1	1		Pannensatz - Emergency kit. Kit de secours - Juego para averias Kit di prima necessità.





Fig.-No.	HATZ Ident-No.	Stück Qty.	P / W d / D	Bemerkungen Notes
		E 573	E 673	
1	00438400	1	1	Zubehörsatz - Accessoires kit Sort. accessoires Juego de accesorios Serie accessori
2	03631102	1	1	
3	03396301	1	1	
4	03589000	1	1	
5	03325510	1	1	
6	03306810	1	1	LS

Dicht- und Klebstoffe  
Sealing- and bonding adhesives  
Etanchéifiant et Colle

Materias para empaquetar y pegar  
Adesivi e collanti

A = 502 230 01	Loctite Activator N	500 ml	} siehe Hinweis auf den einzelnen Bildtafeln as specified in the individual tables suivant les remarques sur les tableau correspondant según las indicaciones de las tablas correspondientes seguire le indicazioni sul quadro corrispondente
B = 502 231 00	Loctite 573	50 ml	
C = 502 232 00	Loctite 601	50 ml	
D = 502 233 00	Loctite 221	50 ml	
E = 502 234 00	Loctite 648	10 ml	
F = 502 238 00	Technicoll 8058	0,75 kg	
+ 502 239 00	Technicoll 8367	0,75 kg	
G = 502 565 01	Loctite IS 407	20 g	
H = 502 825 01	Silicon	30 ml	
J = 502 830 02	Hochtemp. Paste	1000 g	

M 01

Kurbelgehäuse  
Crankcase  
Carter moteur  
Caja cigueñal  
Basamento motore

Tafel Nr.  
Tabl. No.  
Tavola N.

03

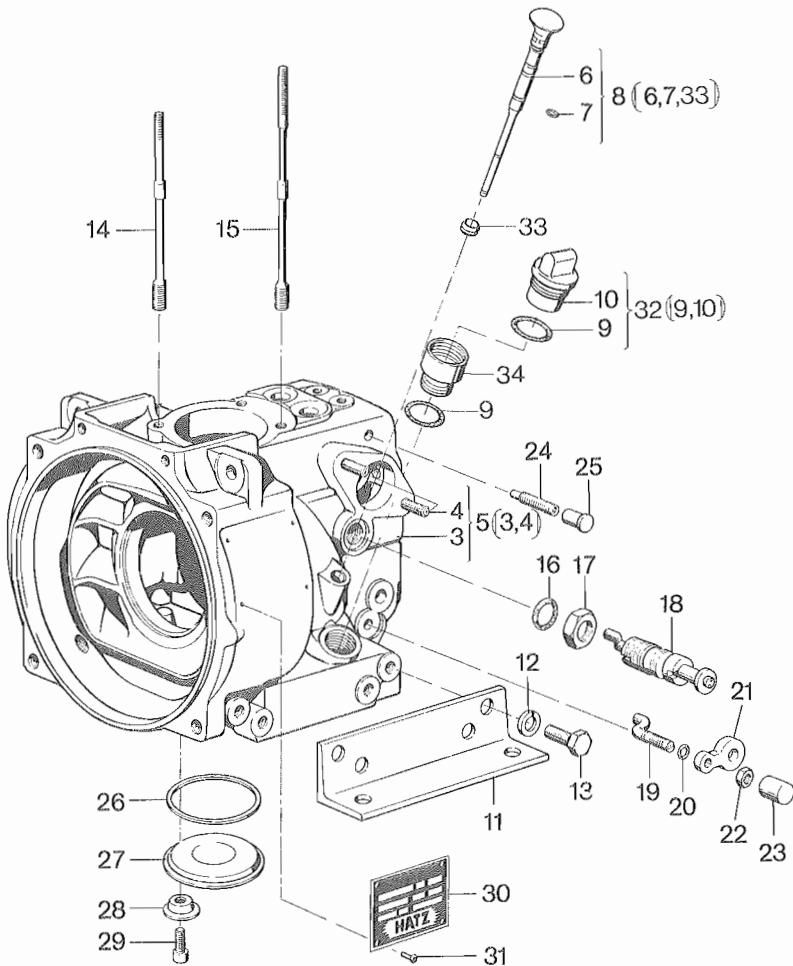

Fig.-No.	HATZ Ident-No.	Stück Qty.	P / W d / D	Bemerkungen Notes
		E 573	E 673	
1	-----	-	-	
2	-----	-	-	
3	-----	-	-	
4	50037300	2	2	M 8 X 18 DIN 835-10.9
5	00912800	1	1	
6	-----	-	-	
7	40022000	2	2	D2 5 X 2
8	00308802	1	1	
9	50153800	2	2	D1 23 X 3
10	-----	-	-	
11	03062100	2	2	
12	50002900	8	8	10 DIN 128
13	50029200	8	8	M 10 X 25 DIN 933-8.8
14	03207701	2	2	
15	03207600	2	2	
16	40022800	1	1	D1 15 X 3,2
17	50024600	1	1	M 20 X 1,5 DIN 936-17H
18	00362400	1	1	
19	03060403	1	1	
20	40021700	1	1	D1 4,47 X 1,78
21	03104901	1	1	
22	50022900	1	1	M 8 DIN 934-8
23	03205800	1	1	
24	50062100	1	1	M 8 X 25 DIN 915 TU. FLEC
25	40039701	1	1	
26	40023800	1	1	D1 74 X 3
27	03205602	1	1	
28	03206200	4	4	
29	50050400	4	4	M 6 X 8 DIN 6912-8.8
30	03225504	1	1	
31	40002500	4	4	2,4 X 6
32	00632101	1	1	W1
33	50324400	1	1	
34	03658400	1	1	

**M 01**

Drehzahlverstellung  
Speed control  
Reglage régime  
Ajuste de revoluciones  
Regolatore di giri

Tafel Nr.  
Tabl. No.  
Tavola N.

**04**

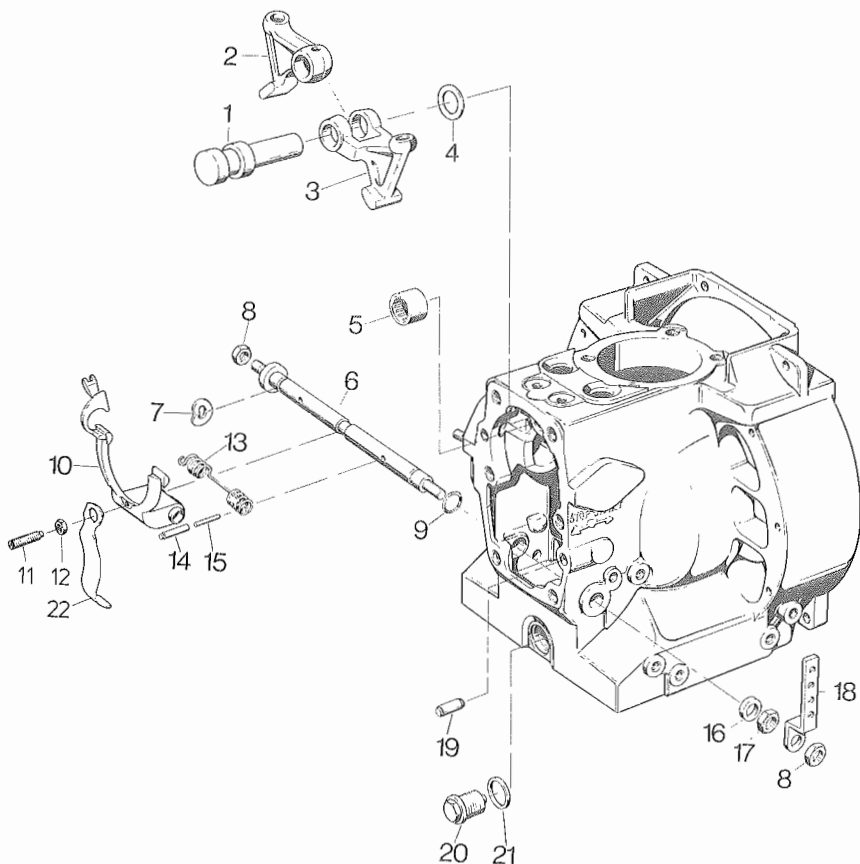

Fig.-No.	HATZ Ident-No.	Stück Qty.	P / W d / D	Bemerkungen Notes
		E 573	E 673	
1	03059700	1	1	
2	03063401	1	1	
3	03063301	1	1	
4	03169800	1	1	0,50 mm
5	40036800	1	1	
6	00427303	1	1	
7	50003600	1	1	B 12      DIN 137
8	50023500	2	2	M 10      DIN 934-8
9	40022300	2	2	D2        8 X 2
10	00308704	1	1	
11	50004200	1	1	M 6 X 20    DIN 915-45 H
12	50144400	1	1	M 6        DIN 934-8 A3C
13	03206500	1	1	2,0 mm Ø ...1800 min <sup>-1</sup>
13	04007200	1	1	2,4 mm Ø >1800...2000 min <sup>-1</sup>
13	03205704	1	1	2,7 mm Ø >2000 min <sup>-1</sup>
13	03444201	1	1	2,6 mm Ø    3000 min <sup>-1</sup> Gen.
14	50034900	2	2	5 X 36      DIN 1481
15	50034300	2	2	3 X 36      DIN 1481
16	03146201	1	1	
17	03206100	1	1	
18	03206000	1	1	
19	03169300	2	2	
19	50058600	1	1	„LS“ 8 M 6 X 50 DIN 7-9 S20K
20	03169103	1	1	W1        R 1/2
21	50001500	1	1	W7,D1    A 21 X 26    DIN 7603-Cu
22	04065500	1	1	Gen.

**M02**

Kurbelwelle  
Crankshaft  
Vilebrequin  
Cigüeñal  
Albero a gomito

Tafel Nr.  
Tabl. No.  
Tavola N.

**05**

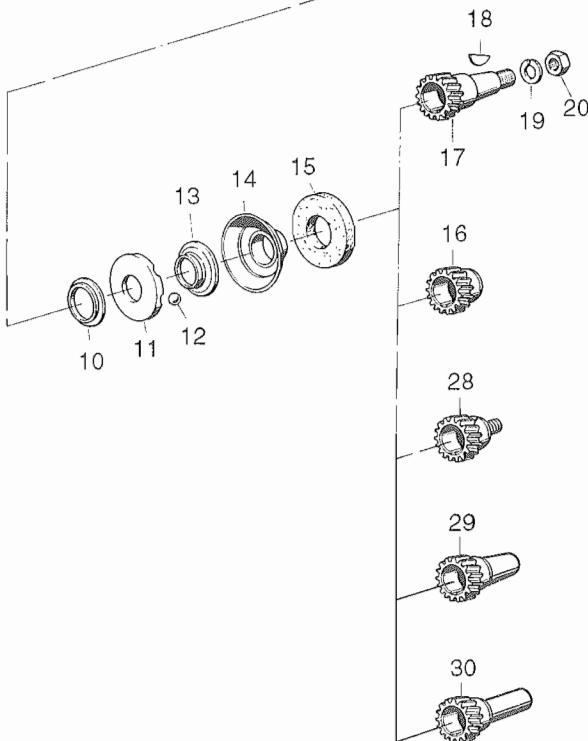
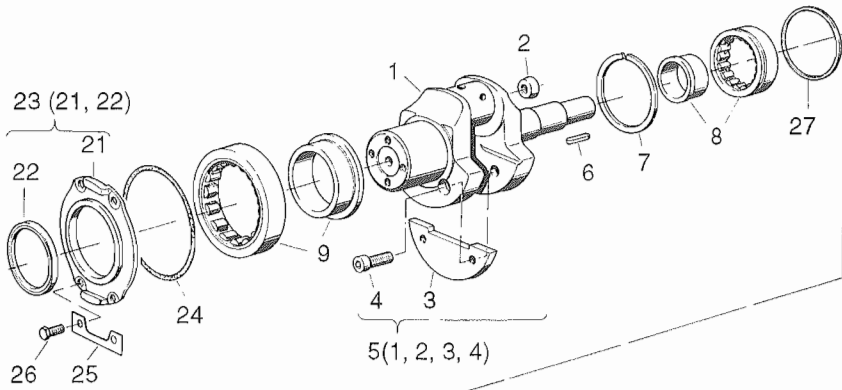

Fig.-No.	HATZ Ident-No.	Stück Qty.	P / W d / D	Bemerkungen Notes
		E 573	E 673	
1	-----	-	-	
2	03195000	1	1	
3	03060901	2	2	
4	50051800	4	4	M 8 X 18 DIN 912-8.8
5	00361202	1	1	
6	50011100	1	1	A 6 X 4 X 28 DIN 6885
7	50036200	1	1	Sp 72 DIN 5417
8	50047700	1	1	
9	50047100	1	1	
10	03206600	1	1	
11	03006602	1	1	
12	50010000	4	4	
13	03170002	1	1	
14	00742000	1	1	
14	01213200	1	1	Gen.
15	03004501	1	1	
16	03064801	1	1	LN/LNF/LS/RN/RNF/LHK/RHK/L3N
17	03064901	1	1	LK/LKF/RK/RKF
18	50017900	1	1	6 X 7,5 DIN 6888
19	50003200	1	1	16 DIN 128
20	50024500	1	1	M 16 X 1,5 DIN 936-17 H
21	-----	-	-	
22	40034200	1	1	D1 60 X 75 X 8/9
23	00563001	1	1	
24	50154000	1	1	D1 110 X 3
25	03205901	2	2	
26	50025500	4	4	M 6 X 12 DIN 933-8.8
27	03380400	0...1	0...1	0,10 mm
27	03380500	0...1	0...1	0,20 mm
27	03380600	0...1	0...1	0,30 mm
27	03380700	0...1	0...1	0,40 mm
27	03380800	0...1	0...1	0,50 mm
28	03945800	1	1	LR
29	05021900	-	1	L36, R36 „Italia“ Nr. 6
30	05048700	-	1	R47 3/4 SAE A Nr. 7



**M04**

Nockenwelle  
Camshaft  
Arbre à cames  
Arbol de levas  
Albero a camme

**M11**

Steuerdeckel  
Timing cover  
Couvercle distr.  
Tapa de mando  
Coperchio distribuzione

Tafel Nr.  
Tabl. No.  
Tavola N.

**06**

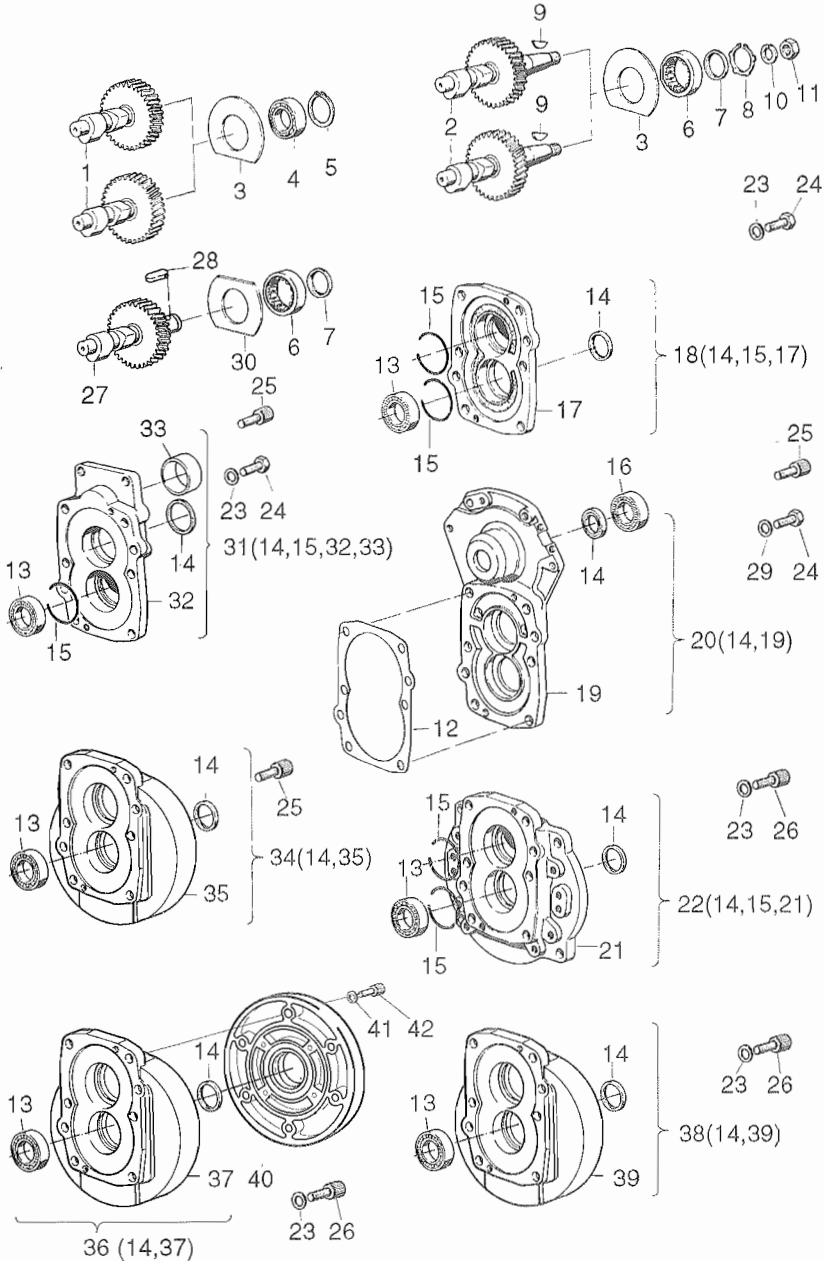

Fig.-No.	HATZ Ident-No.	Stück Qty.	P / W d / D	Bemerkungen Notes
		E 573	E 673	
1	03405901	1	1	LK/LKF/LR/L36
1	03405601	1	1	RK/RKF/R36/R47
2	03430000	1	1	LN/LNF/LHK/L3N
2	03405800	1	1	RN/RNF/RHK
3	03209300	1	1	
4	50012900	1	1	LK/LKF/RK/RKF/LR
5	50020900	1	1	LR/LKF/RK/RKF 30 X 1,5 X DIN 471
6	50062200	1	1	LN/LNF/RN/RNF/LS/LHK/RHK
7	03278000	1	1	LN/LNF/RN/RNF/LS/LHK/RHK
8	40037900	1	1	LN/LNF/RN/RNF/LHK/RHK
9	50017900	1	1	6 X 7,5 DIN 6888
10	50003200	1	1	16 DIN 128
11	50024500	1	1	M 16 X 1,5 DIN 936-17H
12	03209202	1	1	D1
13	50012900	1	1	
14	40033700	1	1	D1 30 X 47 X 8
15	03612400	2	2	LK/LN/RK/RN/LKF/LNF/RKF/RNF
15	03612400	1	1	LHK/RHK
16	50321200	1	1	LS
17	-----	-	-	
18	00362110	1	1	LK/LN/RK/RN
19	-----	-	-	
20	01236800	1	1	LS
21	-----	-	-	
22	00362210	1	1	LKF/LNF/RKF/RNF
23	50001000	5	5	D5 A 10 X 16 DIN 7603-Cu
24	50029200	6	6	LK/LN/RK/RN M 10 X 25 DIN 933-8.8
24	50029200	2	2	LS M 10 X 25 DIN 933-8.8
24	50029200	4	4	LHK/RHK M 10 X 25 DIN 933-8.8
25	50053800	2	2	LHK/RHK M 10 X 25 DIN 912-8.8
25	50053800	4	4	LS M 10 X 25 DIN 912-8.8
25	50053800	6	6	LR M 10 X 25 DIN 912-8.8
26	50054100	6	6	LKF/LNF/RKF/RNF/L36/R36/L3N M10 X 30 DIN 912-8.8
27	03912900	1	1	LS
28	50321400	1	1	6 X 6 X 14 DIN 6885

**M04**

Nockenwelle  
Camshaft  
Arbre à cames  
Arbol de levas  
Albero a camme

**M11**

Steuerdeckel  
Timing cover  
Couvercle distr.  
Tapa de mando  
Coperchio distribuzione

Tafel Nr.  
Tabl. No.  
Tavola N.

**06**

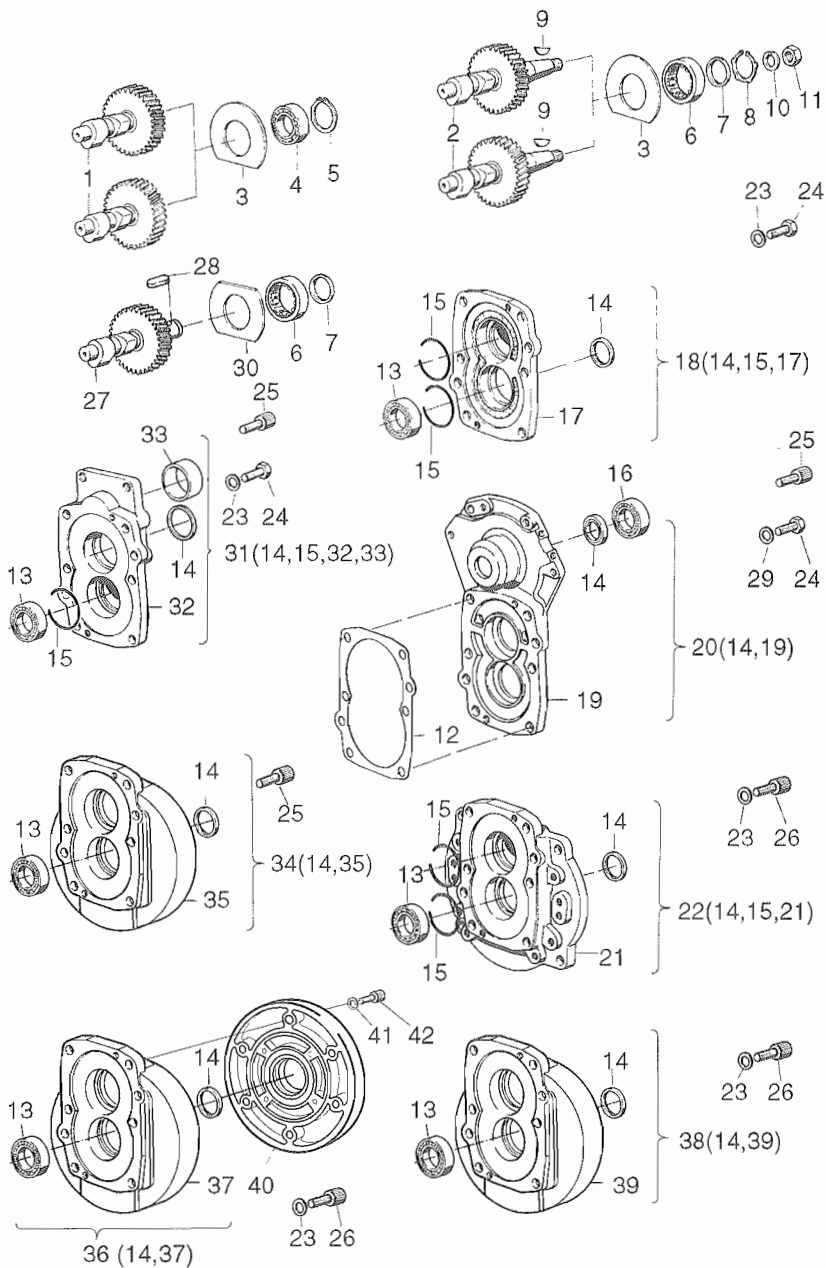

Fig.-No.	HATZ Ident-No.	Stück Qty.	P / W d / D	Bemerkungen Notes
		E 573	E 673	
29	50001000	4	4	D5
30	03939800	1	1	A 10 X 16 DIN 7603-Cu LS
31	00362310	1	1	LHK/RHK
32	-----	-	-	
33	40032900	1	1	LHK/RHK
34	01168200	1	1	LR
35	-----	-	-	
36	01474900	-	1	L36/R36/R47
37	-----	-	-	
38	01503000	-	1	L3N
39	-----	-	-	
40	05049600	-	1	R47
41	50208500	-	6	8 DIN 128-A3C
42	50052000	-	6	M 8 x 20 DIN 6912-8.8

**M05**

Kolben, Pleuel  
Piston, conrod  
Piston, bielle  
Embolo, biela  
Pistone, biella

**M06**

Zylinder  
Cylinder  
Cylindre  
Cilindro  
Cilindro

Tafel Nr.  
Tabl. No.  
Tavola N.

**07**

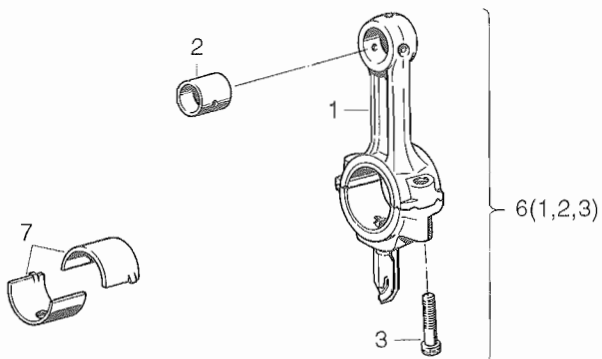
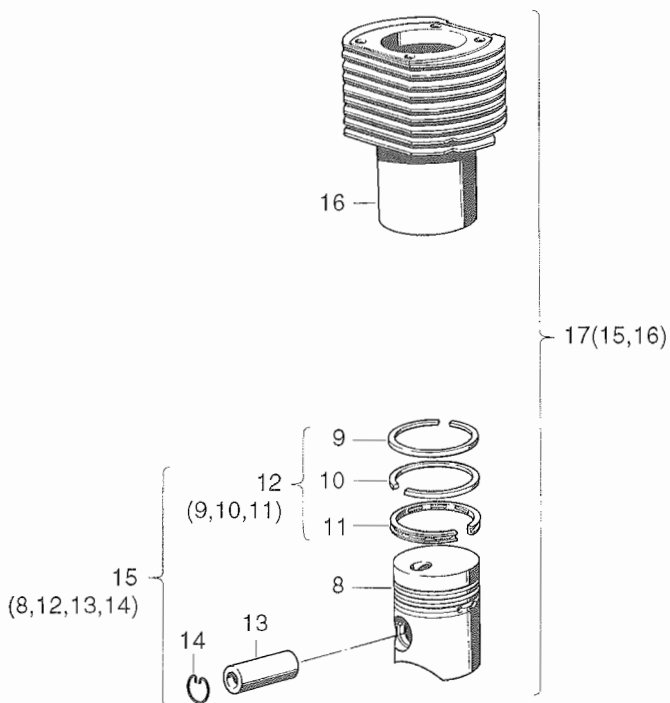

Fig.-No.	HATZ Ident-No.	Stück Qty.	P / W d / D	Bemerkungen Notes
		E 573	E 673	
1	-----	-	-	
2	03206901	1	1	
3	03393700	2	2	
4	-----	-	-	
5	-----	-	-	
6	00361301	1	1	
7	03206700	1	1	
7	03206800	1	1	- 0,5 mm
8	-----	-	-	
9	-----	-	-	
10	-----	-	-	
11	-----	-	-	
12	00904300	1	1	
12	01234000	1	1	+ 0,5 mm
12	00904400	1	1	+ 1,0 mm
13	50107500	1	1	
14	50381210	2	2	A 25 X 1,2 DIN 73130
15	00904103	1	1	
15	01233903	1	1	+ 0,5 mm
15	00909303	1	1	+ 1,0 mm
16	-----	-	-	
17	00912700	1	1	

M07

Zylinderkopf  
Cylinder head  
Culasse  
Culata  
Testa

Tafel Nr.  
Tabl. No.  
Tavola N.

08

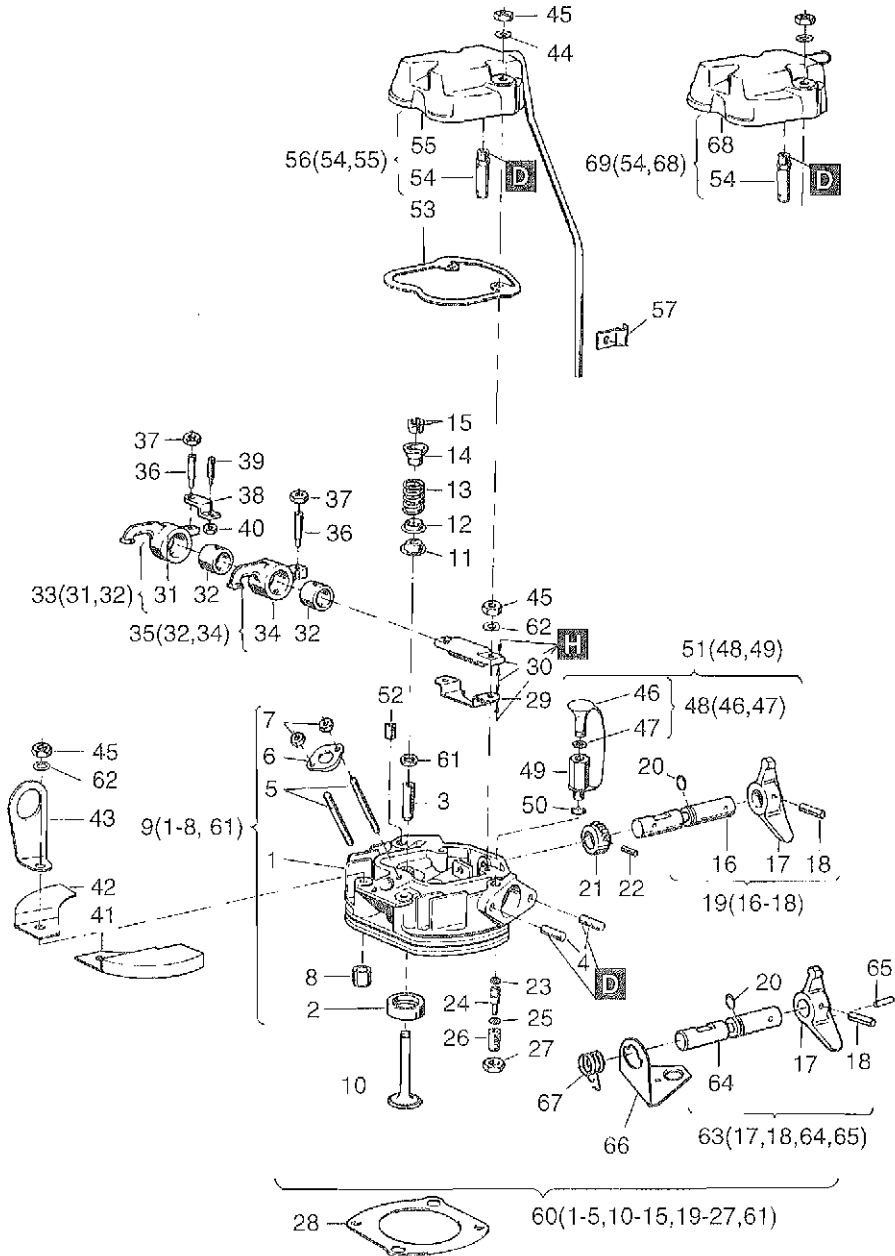

Fig.-No.	HATZ Ident-No.	Stück Qty.	P / W d / D	Bemerkungen Notes
		E 573	E 673	
1	-----	-	-	
2	-----	-	-	
3	03208210	2	2	
4	50037200	4	4	M 8 X 15 DIN 835-10.9
5	50111000	2	2	M 6 X 55 DIN 835-8.8
6	03447300	1	1	
7	50144400	2	2	M 6 DIN 934-8 A3C
8	50035700	2	2	11 X 12 DIN 7346
9	00740121	1	1	
10	03569820	2	2	
11	03208001	2	2	
12	03208400	2	2	
13	03208100	2	2	
14	03060501	2	2	
15	03171910	2	2	
16	-----	-	-	
17	03173401	1	1	
18	50034600	1	1	4 X 18 DIN 1481
19	00746800	1	1	
20	50154300	1	1	d1
21	03570600	1	1	LS/RHK/LHK/LNF/LKF/LN/LK/ RNF/RKF/RN/RK
22	50034100	1	1	3 X 16 DIN 1481
23	50154200	1	1	d1 5 X 1
24	03063800	1	1	
25	50042600	10	10	A 8 DIN 2093
26	03061100	1	1	
27	50023800	1	1	BM10 DIN 439-6
28	03770300	0...1	0...1	0,30 mm
28	03581800	0...1	0...1	d1 0,40 mm
28	03581900	0...1	0...1	0,50 mm
28	03582000	0...1	0...1	d1 0,60 mm
28	03582100	0...1	0...1	0,70 mm
28	03582200	0...1	0...1	0,80 mm
29	03092500	1	1	
30	03061501	1	1	
31	-----	-	-	



M07

Zylinderkopf  
Cylinder head  
Culasse  
Culata  
Testa

Tafel Nr.  
Tabl. No.  
Tavola N.

08

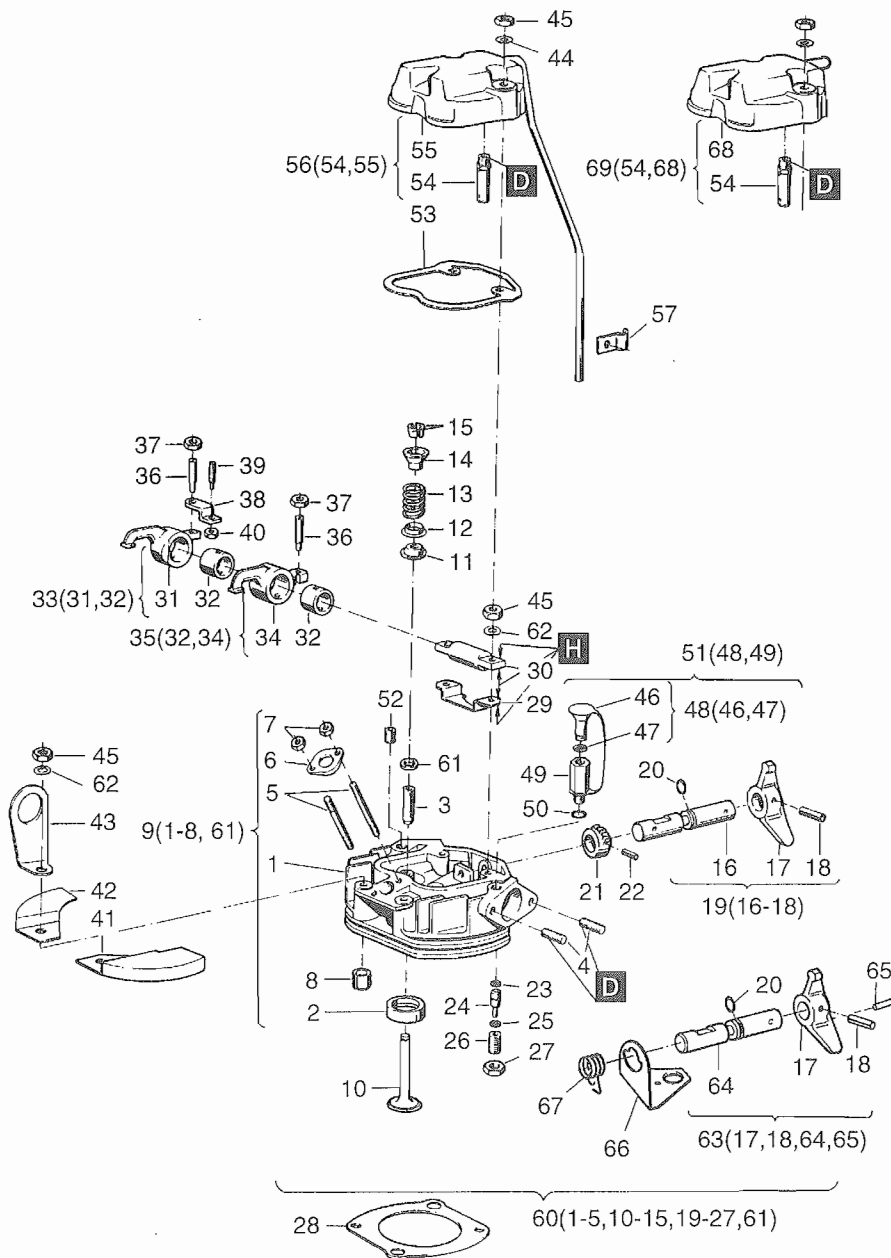

Fig.-No.	HATZ Ident-No.	Stück Qty.	P / W d / D	Bemerkungen Notes		
		E 573	E 673			
32	03430100	2	2			
33	00614201	1	1			
34	-----	-	-			
35	00614301	1	1			
36	03003700	2	2			
37	03173100	2	2	W2		
38	03060002	1	1			
39	03022001	1	1			
40	50144400	1	1	P2	M 6	DIN 934-8 A3C
41	03066401	1	1			
42	03066501	1	1			
43	03457800	1	1			
44	50003500	2	2	W2	B 8	DIN 137
45	50023400	6	6	P4/W2	M 8 X 1	DIN 934-12
46	-----	-	-			
47	40081700	2	2	d2	12 X 2	
48	00736300	1	1	P1		
49	-----	-	-			
50	50001100	1	1	d1	A 12 X 15,5	DIN 7603-Cu
51	00361801	1	1			
52	50043700	1	1		M 12 X 1,5	DIN 906
53	03208902	1	1	W3,d1		
54	00362004	1	1			
55	-----	-	-			
56	00313802	1	1			
57	-----	-	-			
58	-----	-	-			
59	50051300	1	1		M 8 X 10	DIN 912-8.8
60	00907601	1	1			
61	03753800	2	2			
62	03766300	4	4	P4		
63	01168400	1	1		LR/L36/R36/L3N/R47	
64	-----	-	-			
65	50348600	1	1		3 X 26	DIN 1481
66	03944801	1	1		LR/L36/R36/L3N/R47	
67	03944700	1	1		LR/L36/R36/L3N/R47	
68	-----	-	-			
69	01442811	1	1			

**M 09**

Stoßstange  
Pushrod  
Tige de culbuteur  
Varilla de balancin  
Asta bilanciari

**M 14**

Einspritzausrüstung  
Injection equipment  
Equipement d'injection  
Equipo de inyección  
Equipaggiamento iniezione

Tafel Nr.  
Tabl. No.  
Tavola N.

**09**

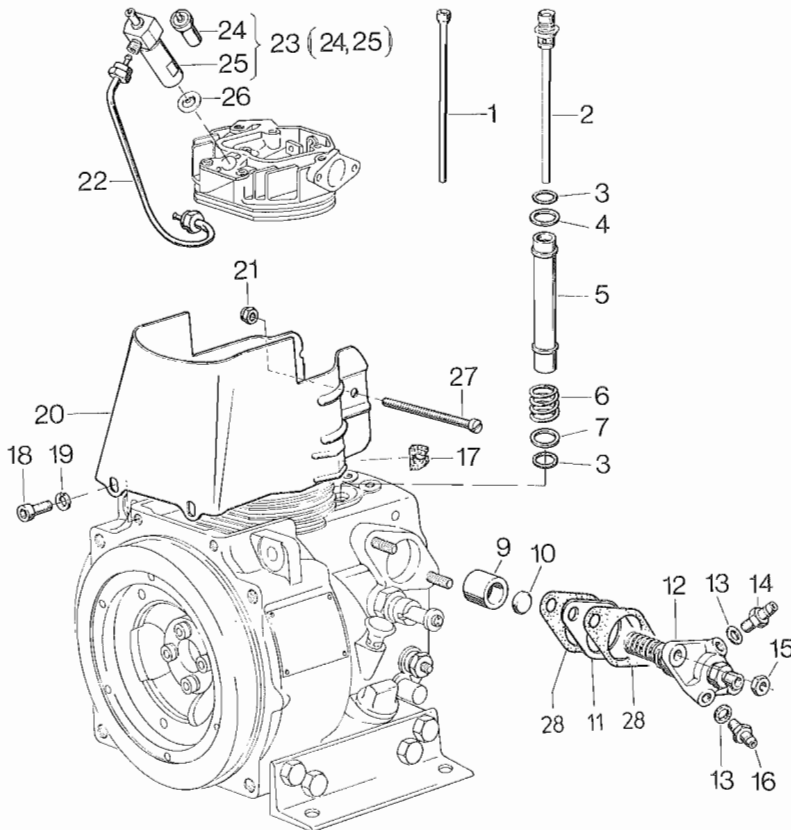

Fig.-No.	HATZ Ident-No.	Stück Qty.		P / W d / D	Bemerkungen Notes
		E 573	E 673		
1	03063901	1	1		
2	00902600	1	1		
3	50288000	4	4	d4	17 X 3
4	03209101	2	2		
5	03209002	2	2		
6	03185100	2	2		
7	03209101	2	2		
8	-----	-	-		
9	03064000	1	1		
10	03062600	1	1		
11	03209500	0...1	0...1		0,15 mm
11	03209700	0...1	0...1		0,30 mm
11	04102400	0...1	0...1		0,60 mm
11	04102800	0...1	0...1		0,65 mm
11	04102500	0...1	0...1		0,90 mm
12	40080201	1	1		
13	50001100	2	2	D2	A 12 X 15,5DIN 7603-Cu
14	00671001	1	1		
15	50022900	2	2		M 8 DIN 934-8
16	03485000	1	1		
17	03150900	1	1		
18	50051600	2	2		M 8 X 16 DIN 912-8.8
19	50148100	2	2		8,4 DIN 125 St A3C
20	03066601	1	1		
21	40028200	1	1		M 5 SSN 440-8 Cu
22	03405700	1	1		
23	40006600	1	1		
24	40004600	1	1	P1	
25	-----	-	-		
26	40003100	1	1	P1	
27	50064600	1	1		M 5 X 80 DIN 84-4.8
28	04071300	0...2	0...2	D2	0,10 mm
28	04102200	0...2	0...2		0,20 mm
28	04102300	0...2	0...2		0,30 mm

**M 15**

Andrehvorrichtung  
Starting device  
Dispositiv demarrage  
Dispositivo de arranque  
Dispositivo di avviamento

**M 17**

Schwungrad  
Flywheel  
Volant  
Volante  
Volano

Tafel Nr.  
Tabl. No.  
Tavola N.

**10**

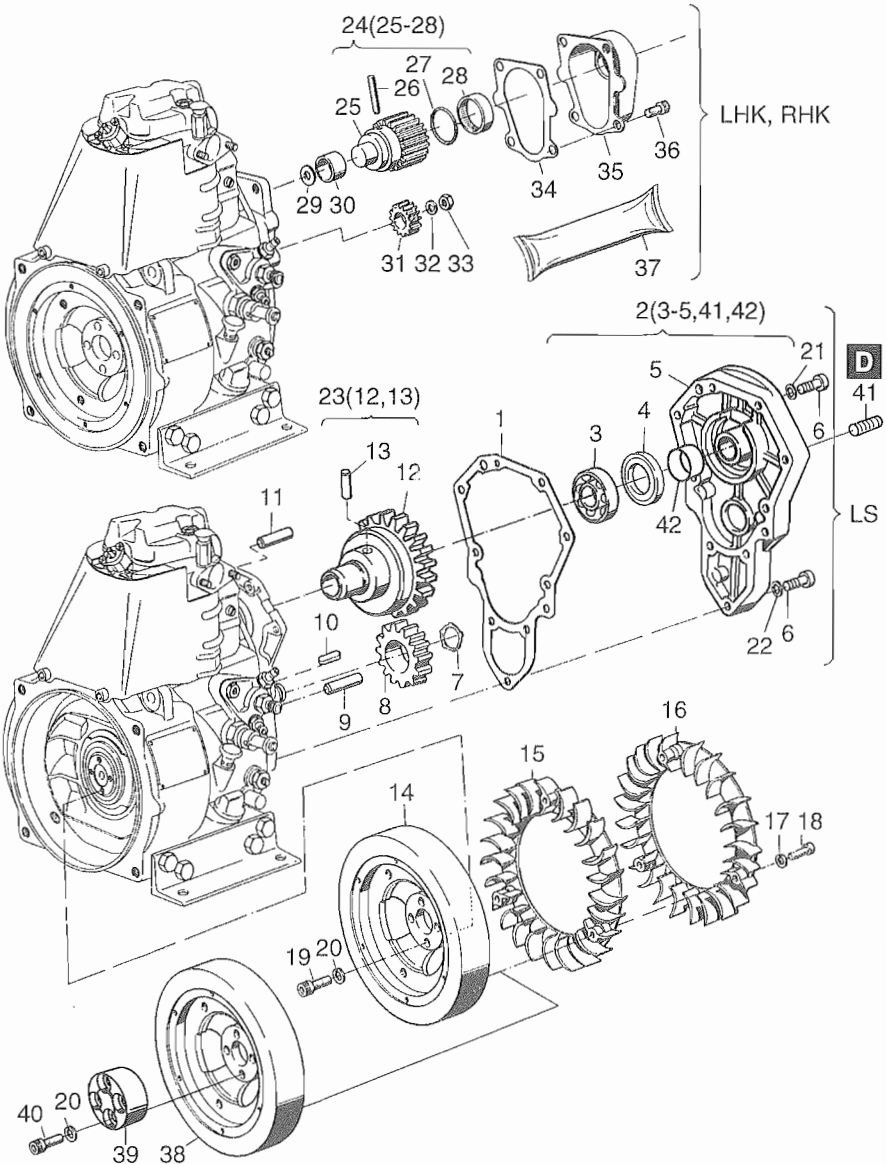

Fig.-No.	HATZ Ident-No.	Stück Qty.	P / W d / D	Bemerkungen Notes
		E 573	E 673	
1	03913100	1	1	
2	01231810	1	1	LS
3	50321300	1	1	
4	40033900	1	1	40 X 52 X 7
5	-----	-	-	
6	50051100	9	9	M 6 X 30 DIN 6912-8.8
7	50324800	1	1	AL 22 X 1,2
8	03912601	1	1	
9	50058600	1	1	8 M 6 X 50 DIN 7-9 S20K
10	50321400	1	1	A 6 X 6 X 14 DIN 6885
11	50349200	1	1	8 m 6 X 32 DIN 6325
12	-----	-	-	
13	03262000	1	1	
14	03063201	1	1	
15	00635000	1	1	LK/LKF/LN/LNF/LS/LHK/L36/L3N
16	00946800	1	1	RK/RKF/RN/RNF/RHK/R36
17	40027800	6	6	
18	40035600	6	6	
19	50054500	4	4	M 10 X 35 DIN 912-10.9
20	50002900	4	4	10 DIN 128
21	50081200	6	6	A 6 DIN 137 A3C
22	50000800	3	3	A 6,5 X 9,5 DIN 7603-Cu
23	01166301	1	1	LS
24	00410611	1	1	LHK/RHK
25	-----	-	-	
26	03262000	1	1	
27	50252400	1	1	D1
28	40019000	1	1	
29	40001300	1	1	
30	40032900	1	1	25 x 28 x 15
31	03112410	1	1	
32	50003200	1	1	16 DIN 128
33	50024500	1	1	M 16 X 1,5 DIN 936-17H
34	03210000	1	1	D1
35	00313701	1	1	
36	50053400	4	4	M 10 X 16 DIN 912-8.8
37	50342600	1	1	LHK/RHK 100 g Fett, grease
38	05020500	-	1	L36/R36/L3N
39	05021300	-	1	L36/R36/L3N
40	50055000	-	4	M 10 X 50 DIN 912-10.9
41	50003900	2	2	M 6 X 5 DIN 551-5.8
42	50387601	1	1	

Reversierstarter  
 Recoil starter  
**M15** Demarreur reversible  
 Arrancador reversible  
 Avviamento a strappo

Tafel Nr.  
 Tabl. No.  
 Tavola N.

11

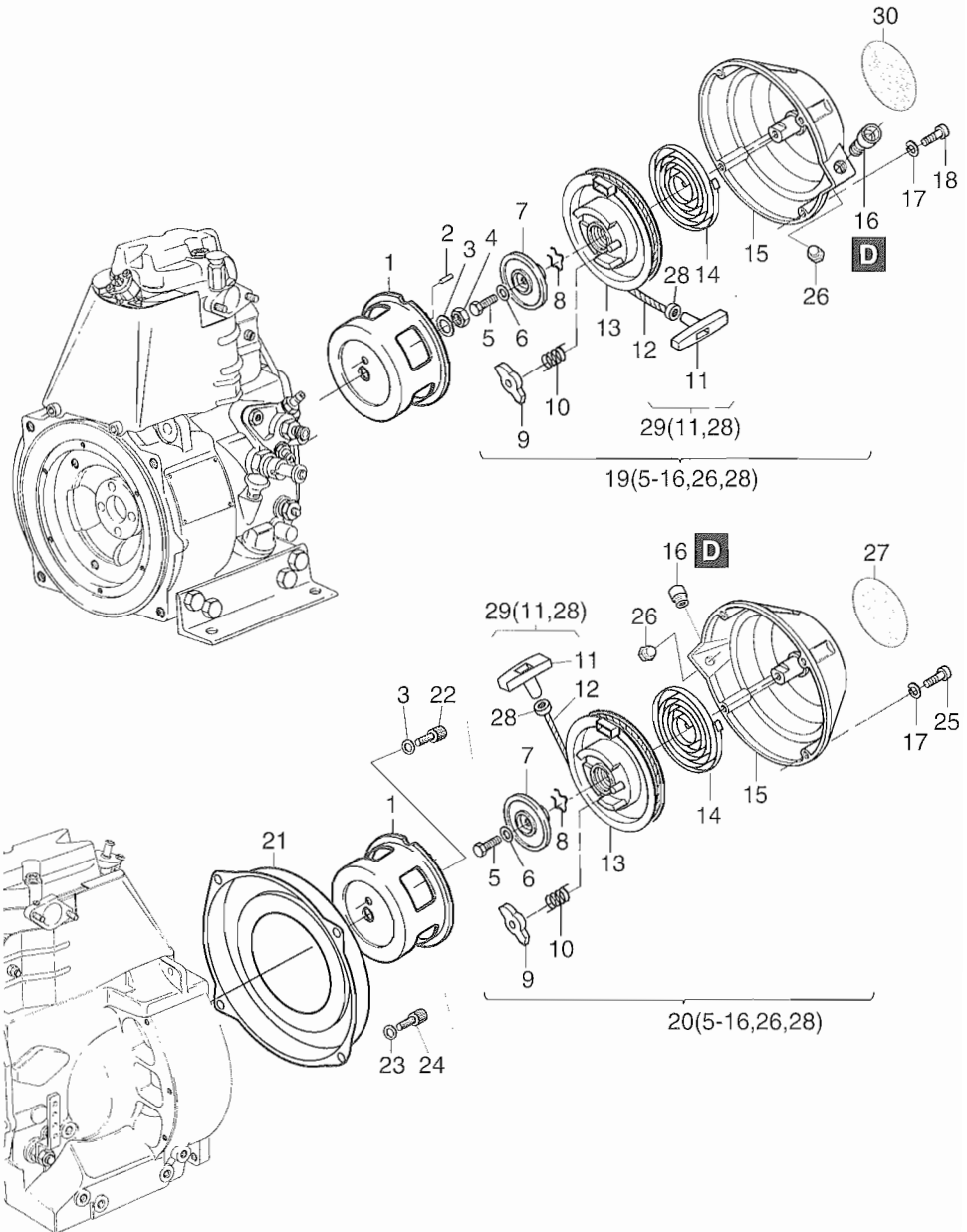

Fig.-No.	HATZ Ident-No.	Stück Qty.	P / W d / D	Bemerkungen Notes
		E 573	E 673	
1	05077900	1	1	
2	50348900	1	1	4 m 6 X 6 DIN 7
3	50348800	1	1	12 DIN 6796 FST
4	50063500	1	1	M 12 DIN 936-17 H A3C
5	50146300	1	1	M 6 X 18 DIN 933-8.8 A3C
6	50165600	1	1	6,5 X 14 DIN 6904 A3C
7	05045000	1	1	
8	05044900	1	1	
9	05044800	1	1	
10	05061300	1	1	LR/R36/R47
10	03996300	-	1	L36/L3N
11	- - - - -	-	-	
12	05068000	1	1	
13	01500500	1	1	
14	05045200	1	1	
15	03944602	1	1	
16	03946800	1	1	
17	50081200	4	4	A 6 DIN 137
18	50170600	4	4	M 6 X 20 DIN 912-8.8 A3C
19	01172702	1	1	LR/R36/R47 (R)
20	01444301	-	1	L36/L3N (L)
21	01475500	1	1	s. Taf., Tabl. 10 - Pos. 38-39
22	50390500	1	1	M 12 X 1,5 X 25 DIN 961 A3C
23	50145900	4	4	10,5 DIN 125 ST A3C
24	50173200	4	4	M 10 X 20 DIN 912-8.8 A3C
25	50170700	4	4	M 6 X 16 DIN 912-8.8 A3C
26	50043700	1	1	M 12 X 1,5 DIN 906
27	05049400	1	1	Hinweisschild, sticker label, plaque, placa, L36/R36
28	03665200	1	1	
29	01497800	1	1	
30	05049300	1	1	Hinweisschild, sticker label, plaque, placa „LR“



**A 01**

Kraftstoffbehälter  
Fuel tank  
Reservoir à carburant  
Depósito combustible  
Serbatoio e circuito combustibile

Tafel Nr.  
Tabl. No.  
Tavola N.

**12**

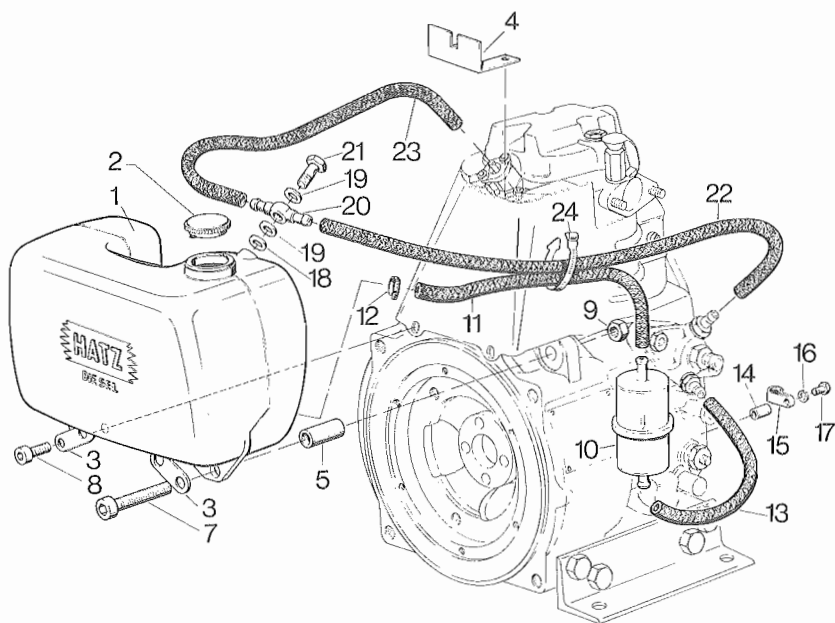

Fig.-No.	HATZ Ident-No.	Stück Qty.		P / W d / D	Bemerkungen Notes
		E 573	E 673		
1	00691300	1	1		140 mm
1	01139400	1	1		(„LS“) 120 mm „kurz“, „short“
2	40032611	1	1	P1	
3	03525800	4	4		
4	03492900	1	1		
5	03493000	2	2		9 X 16 X 31
6	-----	-	-		
7	50171600	2	2		M 8 X 65 DIN 912-8.8 A3C
8	50171500	2	2		M 8 X 25 DIN 912-8.8 A3C
9	40028400	2	2		VM 8 DIN 980-8 C3A
10	40089401	1	1	W2	
11	03493100	1	1		7 X 2,5 - 60 mm
12	40037300	1	1		
13	03493500	1	1		7 X 2,5 - 200 mm
14	03042700	1	1		7 X 12 X 20
15	03165500	1	1		
16	50165600	1	1		6,5 X 14 DIN 6904-A3C
17	50168700	1	1		M 6 X 35 DIN 931-8.8 A3C
18	50158300	1	1		10,5 DIN 125-Cu
19	50062400	2	2	D2	A 10 X 13,5 DIN 7603-Cu
20	40093300	1	1		
21	50169700	1	1		C 4 DIN 7623-Zn
22	03493600	1	1		7 X 2,5 - 330 mm
23	03493300	1	1		7 X 2,5 - 140 mm
24	40092700	1	1		

**A02**

Luftfilter  
Airfilter  
Filtre à air  
Filtro de aire  
Filtro aria

**A03**

Auspufftopf  
Exhaustsilencer  
Silencieux  
Silenciador  
Marmitta

Tafel Nr.  
Tabl. No.  
Tavola N.

**13**

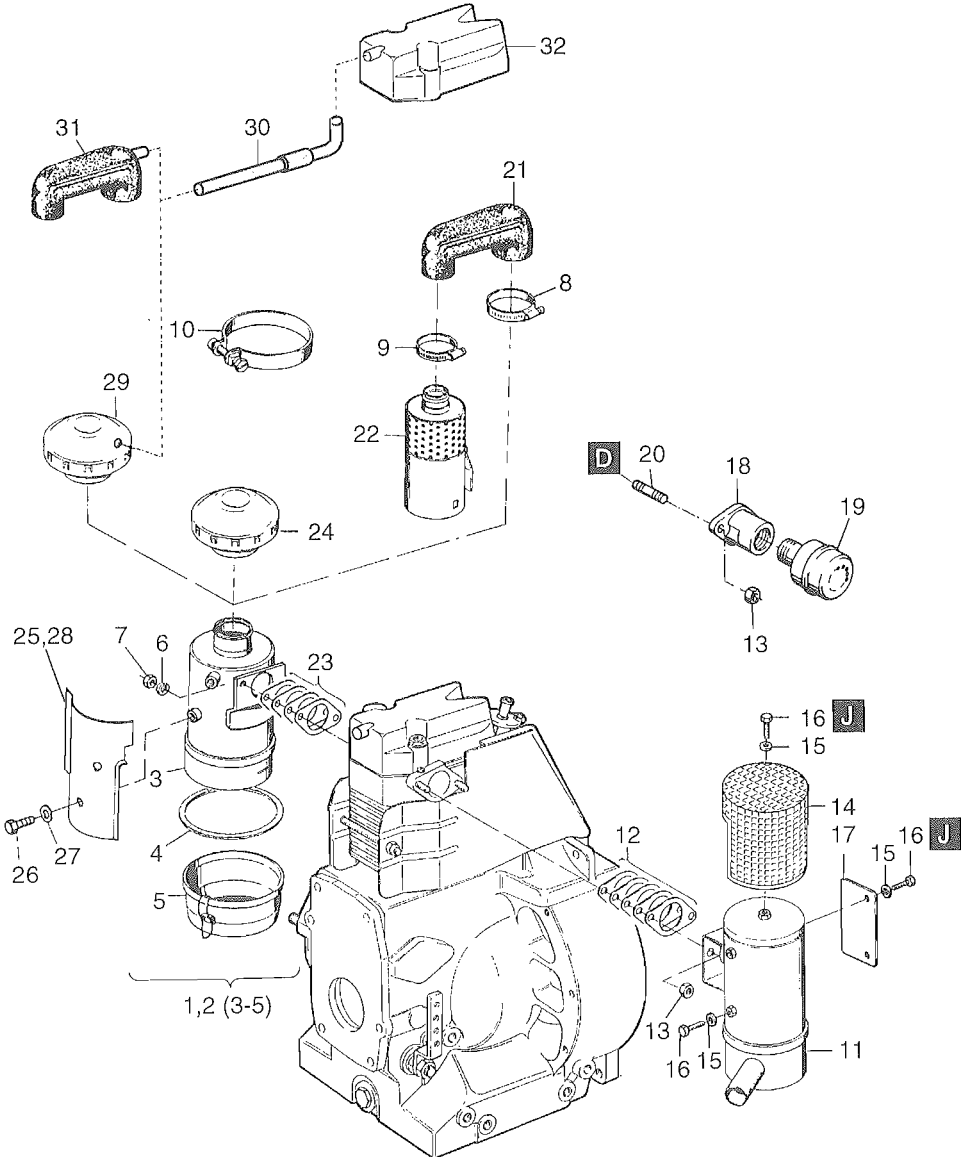

Fig.-No.	HATZ Ident-No.	Stück Qty.		P / W d / D	Bemerkungen Notes
		E 573	E 673		
1	01154400	1	1		LS
2	40099400	1	1		
3	-----	-	-		
4	49037500	1	1	P1	
5	49037600	1	1		
6	50208500	2	2		8          DIN 128-A3C
7	50023000	2	2		M 8 Ms      DIN 934-Ms
8	40053500	1	1		
9	40071500	1	1		
10	40101000	1	1		108/20
11	00864900	1	1		
12	01286100	1	1	d1	
13	40081600	2	2		M 8          Ms
14	00785200	1	1		
15	50016800	6	6		8,4 Ms      DIN 125-Ms
16	50173100	4	4		M 8 X 10    DIN 912-8.8 A3C
17	03699700	1	1		
18	03829000	1	1		R 1 1/4
19	00872200	1	1		R 1 1/4
20	50037800	2	2		M 8 X 22    DIN 835-10.9
21	03324500	1	1		
22	40099600	1	1		
23	01284600	1	1	W1,d1	
24	40099500	1	1	P1	
25	03933001	1	1		LS
26	50333500	2	2		M 6 X 8      DIN 933-8.8 A3C
27	50144500	2	2		6,4          DIN 125-St A3C
28	03940100	1	1		LS f. Taf., Tabl. 15, Pos. 1-20
29	05003400	1	1		Taf., Tabl. 08, Pos. 69
30	01542900	1	1		
31	03324510	1	1		
32	01442811	1	1		

# A04

Andrehkurbel, Startscheibe  
Starting handle, starter pulley  
Manivelle, poulie lancement  
Manivela, polier de arranque  
Manovella, puleggia avviamento

Tafel Nr.  
Tabl. No.  
Tavola N.

14

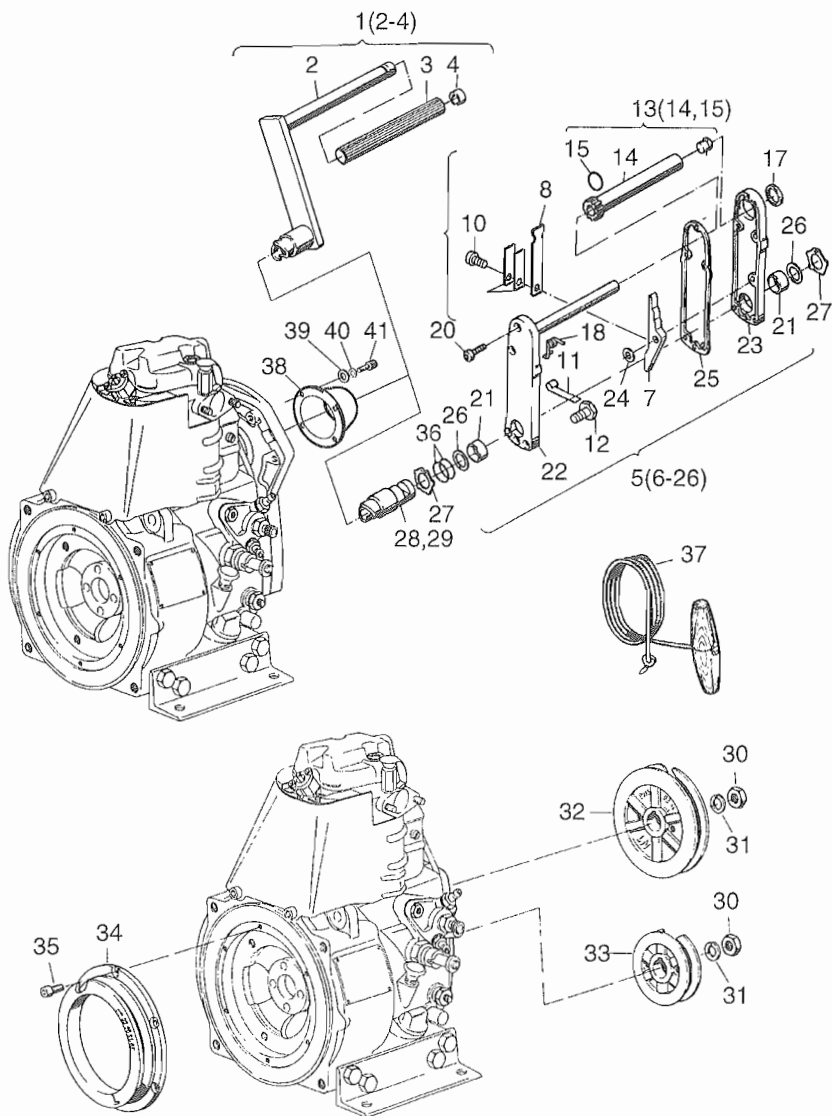

Fig.-No.	HATZ Ident-No.	Stück Qty.	P / W d / D	Bemerkungen Notes
		E 573	E 673	
1	00315000	1	1	LHK
1	00424100	1	1	RHK
1	01140001	1	1	LS
2	-----	-	-	
3	03522400	1	1	
4	03515400	1	1	
5	01027805	1	1	"A"
5	01027905	1	1	"B"
6	01011404	1	1	
7	-----	-	-	
8	03812102	1	1	
9	03917100	2	2	
10	50316500	2	2	M 5 X 8    DIN 6912-8.8 A3C
11	03954900	1	1	
12	03955600	1	1	
13	01011310	1	1	
14	-----	-	-	
15	50169100	1	1	19 X 1,8
16	50199200	1	1	
17	50194200	1	1	
18	03955900	1	1	"A"
18	03956000	1	1	"B"
19	-----	-	-	
20	50194400	5	5	M 6 X 25    WN 11084-8.8 Zn
21	50193400	2	2	
22	-----	-	-	
23	-----	-	-	
24	50195800	1	1	10 X 16 X 0,5 DIN 988
25	03813000	1	1	
26	03928600	2	2	30 X 38 X 0,15
27	50194300	2	2	AK 30 X 1,5
28	01018600	1	1	LHK 50 mm
28	01157801	1	1	LS 80 mm
28	01139902	1	1	LS 60 mm
28	01018800	1	1	LHK 108 mm
28	01047500	1	1	LHK 177 mm

**A04**

Andrehkurbel, Startscheibe  
Starting handle, starter pulley  
Manivelle, poulie lancement  
Manivela, polier de arranque  
Manovella, puleggia avviamento

Tafel Nr.  
Tabl. No.  
Tavola N.

**14**

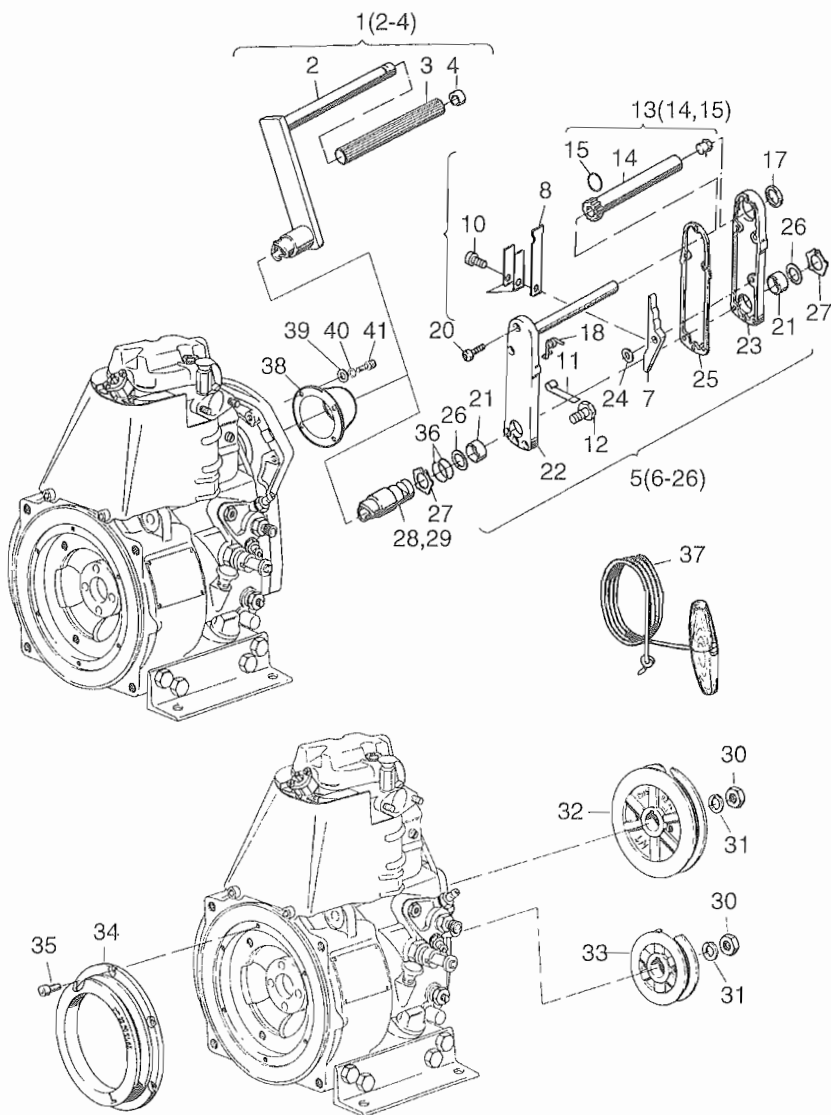

Fig.-No.	HATZ Ident-No.	Stück Qty.	P / W d / D	Bemerkungen Notes
		E 573	E 673	
29	01018700	1	1	RHK 50 mm
30	50024500	1	1	M 16 X 1,5 DIN 936-17 H
31	50003200	1	1	16           DIN 128
32	03091902	1	1	LN
32	03090102	1	1	RN
33	03090202	1	1	LK
33	03090002	1	1	RK
34	03078802	1	1	LK/LKF/LN/LNF
34	03078902	1	1	RK/RKF/RN/RNF
35	50050700	6	6	M 6 X 16   DIN 912-8.8
36	50258500	2	2	26 X 1,5
37	00409400	1	1	
38	03940000	1	1	
39	50144500	4	4	6,4           DIN 125-St A3C
40	50081200	4	4	A6           DIN 137 A3C
41	50149100	4	4	M 6 X 12   DIN 912-8.8 A3C



**A 09**

Drehzahlverstellung  
Speed control  
Reglage régime  
Ajuste de revoluciones  
Comando acceleratore

**A 16**

Wellenstummel, Zentrierflansch  
Stubshaft, cent. flange flyw. side  
Bout de arbre, bride centr. c. vol.  
Eje, brida de centrage  
Contralbero, centraggio

Tafel Nr.  
Tabl. No.  
Tavola N.

**15**

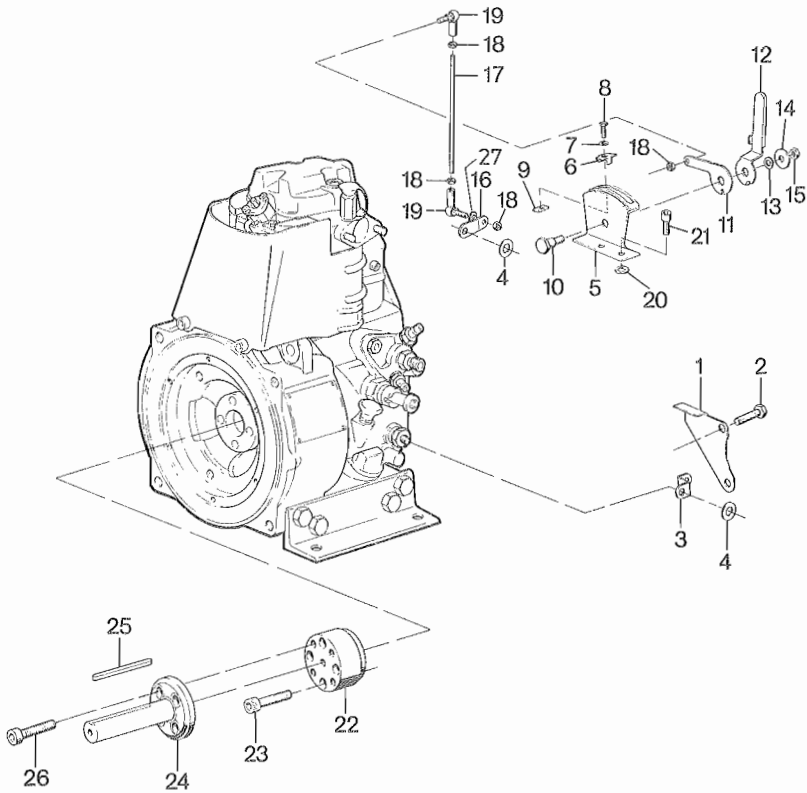

Fig.-No.	HATZ Ident-No.	Stück Qty.	P / W d / D	Bemerkungen Notes
		E 573	E 673	
1	03108200	1	1	LKF/LNF/RKF/RNF L/LK/LN/R/RK/RN
2	50029300	2	2	M 10 X 30 DIN 933-8.8
3	03108100	1	1	
4	03105600	1	1	
5	00720400	1	1	
5	01145800	1	1	LS
6	03112200	2	2	
7	50216300	2	2	5,3 DIN 125-St A3C
8	50025100	2	2	M 5 X 10 DIN 933-8.8
9	03112101	2	2	
10	03511700	1	1	
11	03511600	1	1	
11	03928700	1	1	LS
12	03511500	1	1	
12	03927600	1	1	LS
13	50003500	1	1	B 8 DIN 137
14	50062900	1	1	B 8,4 DIN 9021-St-A3C
15	50023200	2	2	BM 8 DIN 439-5
16	03511900	1	1	
17	03511000	1	1	
17	03928800	1	1	LS
18	50144400	4	4	M 6 DIN 934-8 A3C
19	50133300	2	2	
20	50123000	2	2	8,4 DIN 7349
21	50051900	2	2	M 8 X 20 DIN 912-8.8
22	03094700	1	1	
23	50054800	4	4	M 10 X 45 DIN 912-10.9
24	03027300	1	1	
25	50011700	1	1	A 8 X 7 X 63 DIN 6885
26	50053800	4	4	M 10 X 25 DIN 912-8.8
27	50144500	0...1	0...1	"LR" 6,4 DIN 125-St A3C

### **Anhang für nicht abgebildete Zusatzausrüstung:**

Weitere Zusatzausrüstungen können aus Platzgründen in der Ersatzteilliste nicht mehr detailliert dargestellt werden. Für die Bestellung von Teilen aus nicht abgebildeten Zusatzausrüstungen verwenden Sie bitte nachfolgende Übersicht. Anhand der Skizze ist die gesuchte Zusatzausrüstung auffindbar, die für den jeweiligen Motortyp zugehörige Ident-Nr. der Ausrüstung ist aus der Tabelle ersichtlich.

Ihre zuständige HATZ-Vertretung kann Ihnen anhand dieser Ident-Nr. das gewünschte Ersatzteil herausuchen.

### **Annex for additional equipment which is not illustrated:**

Due to lack of space we cannot list further additional equipment in our parts list: For parts ordering not illustrated, please use the below listed survey. With the aid of sketches you can find the required additional equipment. The ident-number belonging to the corresponding engine type can be taken from the table.

Your HATZ agent is in a position to select for you the required spare part as soon as you have selected the correct ident-number.

### **Annexe concernanti es accessoires complémentaires non-illustrés:**

Un certain nombre d'accessoires complémentaires n'ont pu, par suite d'un manque de place, être représentés d'une manière détaillée dans la liste de pièces détachées. Pour la commande de ces accessoires, qui ne sont pas illustrés, veuillez utiliser l'aperçu ci-après. A l'aide des croquis, il est possible de trouver l'accessoire souhaité, le No. ident. correspondant pour chaque type de moteur figure dans le tableau.

Grâce à ce No. ident. votre représentant HATZ pourra vous trouver la pièce souhaitée.

### **En relación a equipos adicionales no ilustrados:**

Debido a razones de espacio no es posible ilustrar otros equipos adicionales en la lista de piezas. Para pedidos de equipos adicionales no ilustrados favor usen la siguiente orientación. A base de las ilustraciones es posible encontrar el equipo adicional buscado, el número ident para el tipo de motor para el cual se necesita el equipo se puede obtener de la tabla.

El representante HATZ para su area puede entonces a base del número ident encontrar las piezas deseadas.

### **Allegato concernente gli accessori complementari non illustrati:**

Un certo numero di accessori complementari non sono stati inseriti in modo dettagliato sul catalogo ricambi per mancanza di spazio. Per effettuare un ordine di questi accessori vogliate utilizzare le tavole che seguono. Con l'aiuto dei disegni è possibile trovare il pezzo desiderato, ed il codice corrispondente per ogni tipo di motore.

Con il codice del pezzo il vostro concessionario HATZ potrà soddisfare la vostra richiesta.

**Zusatzausrüstungen****Equipements****Accessoires complémentaires****Accessori complementari****Equipos**

Code

Ident-No.

E 573

E 673

Bemerkungen

Notes

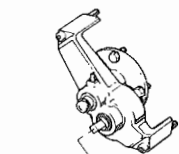

A 04.70 00584301

L

L

A 04.70 00584401

R

R

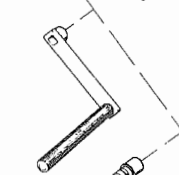

A 04.70 01044400

X

X

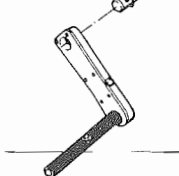

A 04.70 01018002

L

L

A 04.70 01044300

R

R



A 05.20 00475202

R

L/R

A 05.20 00475002

RK

L/RK

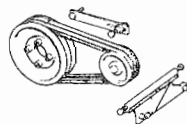

A 05.30 00475101

L/R

L

A 05.30 00474601

LK/RK

LK/RK

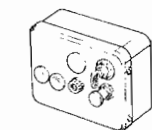

A 05.60 00779501

X

X

A 05.60 00716102

X

X

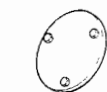





A 08.10 00406300

X



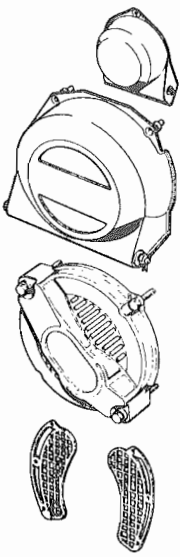

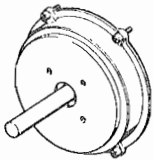
X

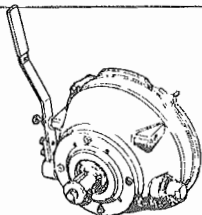
**Zusatzausrüstungen**  
**Equipements**  
**Accessoires complémentaires**  
**Accessori complementari**  
**Equipos**

Bemerkungen  
 Notes

	Code	Ident-No.	E 573	E 673	
	A 12.20	00624500	X	X	
	A 12.20	00624700	X	X	
	A 12.20	00624600	X	X	
	A 12.20	00728000	X	X	
	A 12.20	00868100	X	X	
	A 16.20	00474100	X	X	
	A 16.20	00682400	X	X	
	A 15.20	01131700	X	X	
	A 16.20	01132100	X	X	
	A 15.20	01132200	X	X	
	A 16.20	01132100	X	X	
	A 16.30	00474000	X	X	
	A 16.30	00474400	X	X	
	A 17.11	00475800	X	X	

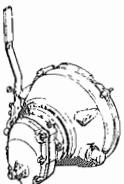
**Zusatzrüstungen**  
**Equipements**  
**Accessoires complémentaires**  
**Accessori complementari**  
**Equipos**

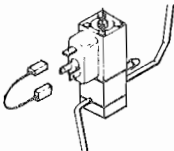
	Code	Ident-No.	E 573	E 673	Bemerkungen Notes
	A 17.30	00404800	X	X	
	A 17.30	00404900	X	X	
	A 17.50	00486400	X	X	
	A 17.50	00486500	X	X	
	A 20.10	00480301	X	X	i = 1,8
	A 21.10	00485500	X	X	i = 10,4
	A 21.10	00496601	LKF, LNF RKF, RNF	LKF, LNF RKF, RNF	i = 6,6
	A 21.10	00496401	LKF, LNF RKF, RNF	LKF, LNF RKF, RNF	i = 10,4
	A 11.10	01086500	X	X	12 V
	A 11.10	01182200	X	X	

**Serien-Nr.-Änderungen**  
**Serial-code modification list**  
**Modification des Nos de serien**  
**Modificación de los Nos de serie**  
**Modifica dei codici**

Bildtafel	Pos. No.	Bestell-Nr.	Stück	Bildtafel	Pos. No.	Bestell-Nr.	Stück	
Table	Fig. No.	Ordering No.	Qty.	Table	Fig. No.	Ordering No.	Qty.	IMT
Planche	Fig. No.	No. référence	Qté.	Planche	Fig. No.	No. référence	Qté.	No.
Tabla	Fig. No.	No. de pedido	Cant.	Tabla	Fig. No.	No. de pedido	Cant.	
Tavola	Rif.	Codice	Q.tà	Tavola	Rif.	Codice	Q.tà	

E 573.10

E 573.11

E 673.10

E 673.11

83.413

06	3	03208200	2	≠	08	3	03208210	2
06	9	00740120	1	=	08	9	00740121	1
06	10	03569810	2	≠	08	10	03569820	2
06	15	03208301	2	≠	08	15	03171910	2
06	61	-----	-		08	61	03753800	2





