

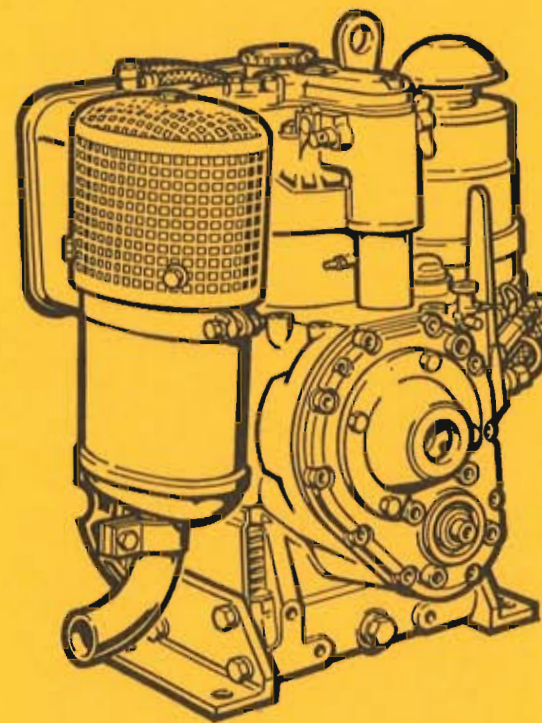

Motorenfabrik HATZ GmbH & Co KG
 D-8399 Ruhstorf a. d. Rott
 Tel.: 08531/319-1, Telex: 57260, Telefax: 08531/32716

Ersatzteil-Liste
Spare parts list
Liste des pièces de rechange
Lista de recambios



- E 71**
- E 75**
- E 79**
- E 780**
- E 786**

Druck: Krönner, 34/456-6. '88-10
 Printed in West-Germany

Schutzgebühr DM 3.—
 Protection tax
 Taxe de protection
 Derecho de protección DM

- No. E 71.16
- No. E 75.15
- No. E 79.15
- No. E 780.15
- No. E 786.11

WICHTIG — Bitte Daten eintragen
IMPORTANT — Compléter les données

IMPORTANT — Please enter data
IMPORTANTE — Favor completar datos

1.

Bitte hier **Type**, **Motornummer** und **Drehzahl** (siehe Motor-Typenschild) eintragen.

Enter here **type**, **engine no.** and **rpm.** (see engine type-plate).

Indiquer ici le **type**, **N° de moteur** et **régime** (voir plaque signalétique).

Insertar aquí **tipo- N° motor** y **r.p.m.** (vea placa del motor).



MOTORENFABRIK HATZ <small>LAUBH. KG</small>			
D-8399 RUHSTORF/ROTT			
TYP	KENNZ.		
MOTOR / FABRIK NO.	ABE/AUSEF.		
MIN ⁻¹	NH	PV	CM ³
HATZ			
DIESEL			
MADE IN GERMANY (FED. REP.)			

1

2.

Bitte **Ersatzteillistennummer** (siehe Titelseite) gemäß Type ankreuzen, z. B. bei Typ E 71:

E 71.16

Mark spare parts list no. (see title-page) acc. to type, e. g. for type E 71:

E 71.16

Cocher le N° de liste de pièces de rechange (voir: couverture) selon type, par. ex. E 71:

E 71.16

Marcar N° lista de recambios (ver: frontispició) de acuerdo aipo, ejemplo tipo E 71:

E 71.16



Ersatzteilliste Nr.

Spare parts list no.

Liste des pièces de rechange no.

Lista de recambios no.

E 71.16 E 75.15 E 79.15

E 780.15 E 786.11

2

3.

Bitte tragen Sie hier die **Anschrift** Ihrer nächsten HATZ-Service-stelle ein.

Insert here **address** of your next HATZ Service station.

Indiquer ici l'**adresse** de votre stationservice HATZ la plus proche.

Insertar aquí **dirección** de servicio HATZ más cercano.



HATZ-Service

3

MOTORENFABRIK HATZ
GmbH & Co. KG
D-8399 RUHSTORF a. d. ROTT
Federal Republic of Germany
☎ (0 85 31) 319-1 ☒ 5 7260

1

Angaben bei Ersatzteilbestellungen:

Zur richtigen und schnellen Belieferung mit Ersatzteilen sind folgende Angaben erforderlich:

1. **Type, Motornummer** und **Drehzahl** des Motors, für den das Ersatzteil benötigt wird: siehe Angaben auf Seite 1, Feld 1.
2. **Nummer der Ersatzteilliste**, aus der die Bestellnummer herausgelesen wurde: siehe Seite 1, Feld 2.
3. **Stückzahl** und **Bestell-Nr.** des gewünschten Ersatzteils.
4. Gewünschte **Versandart**, z. B. Post, Luftfracht, Express.
5. Genaue **Versandadresse**, wenn erforderlich mit Post- u. Bahnstation.

Bestellbeispiel:

Für Motortype: ES 71 - 177 b
Motornummer: 231687031814
min⁻¹ 3000/60

aus Ersatzteil-Liste E 71.16
folgende Teile:

Stück	Bestell-Nr.
2	003 409 01
6	031 684 00

per Postexpress an . . .

Die Ersatzteilbestellung richten Sie bitte an:

- die nächste HATZ-Servicestelle, Anschrift siehe Seite 1, Feld 3 oder separates Servicestellenverzeichnis.
- oder an die

Motorenfabrik Hatz GmbH & Co. KG
D - 8399 Ruhstorf a. d. Rott
Federal Republic of Germany
☎ (08531) 319-1 — ☎ 57260

Particulars for spare parts orders:

The following information is needed to ensure correct and prompt supply of spare parts:

1. **Engine type, engine number** and **r. p. m.** of the engine for which you need the spare part.
See particulars on page 1, field 1.
2. **Number of spare parts list** from which you too the ordering no., see page 1, field 2.
3. **Quantity** and **ordering no.** of requested spare part.
4. Requested **mode of dispatch**, e. g. surface / airmail, airfreight, express.
5. Exact **shipping address**, if necessary indicate local post office and/or railway station.

Example for your order:

For engine type: ES 71 - 177 b
Engine number: 231687031814
R.p.m.: 3000/60

Spare parts list no. E 71.16
The following parts:

Qty.	ordering-no.
2	003 409 01
6	031 684 00

to be mailed, express, to . . .

Please address your spare parts order to:

- your nearest Hatz service station, address see page 1, field 3 or separate Hatz-service-List
- or to

Motorenfabrik Hatz GmbH & Co. KG
D - 8399 Ruhstorf a. d. Rott
Federal Republic of Germany
☎ (08531) 319-1 — ☎ 57260

Données à indiquer lors de vos commandes de pièces détachées:

Pour nous permettre de livrer vos pièces rapidement et correctement, nous avons besoin des données suivantes:

1. **Type, No. et régime du moteur** pour lequel vous avez besoin de pièces: voir données page 1, carré 1.
2. **No. de la liste de pièces de rechange** dans laquelle figure le No. de commande: voir page 1, carré 2.
3. **Quantité et No. de commande** de la pièce souhaitée.
4. **Mode d'expédition** souhaitée: par ex. par poste, frêt aérien, exprès.
5. **Adresse exacte de destination** et, lorsque ceci est nécessaire, le nom de la poste ou de la gare, ou aéroport.

Exemple:

Pour type de moteur: ES 71 - 177 b
No. moteur: 231687031814
Régime: 3000/60

Liste de pièces de rechange: E 71.16
Les pièces suivantes:

Qté	No. commande
2	003 409 01
6	031 684 00

par poste exprès à ...

Les commandes de pièces détachées sont à adresser à:

— votre station-service HATZ la plus proche, voir adresse page 1, carré 3 ou liste de service séparée.

— ou

Motorenfabrik Hatz GmbH & Co. KG
D - 8399 Ruhstorf a. d. Rott
République Fédérale d'Allemagne
☎ (0 85 31) 319-1 — ☎ 57260

Datos para pedidos de recambios:

Para recibir sus recambios en forma rápida y correcta necesitamos las siguientes informaciones:

1. **Tipo, número del motor y revoluciones:**
ver detalles en página 1, posición 1.
2. **Número de la lista de recambios** de la cual se ha obtenido el número de pedido: ver página 1, posición 2.
3. **Cantidad y número de pedido del recambio deseado.**
4. Tipo de **despacho deseado:** por ej. correo, flete aéreo, expreso etc.
5. **Dirección exacta**, si necesario indicar la oficina de correo, la estación ferrocarril o aeropuerto.

Ejemplo de pedido:

Para motor tipo: ES 71 - 177 b
Número de motor: 231687031814
R. P. M.: 3000/60

De la lista de recambios: E 71.16
Sigüientes recambios:

Cantidad	Número de pedido
2	003 409 01
6	031 684 00

Por correo expreso a ...

El pedido de recambios favor dirigrlo a:

— Al servicio HATZ más cercano, dirección verla en página 1, posición 3 or en el índice separado de direcciones de servicio.

— Alternativa a:

Motorenfabrik Hatz GmbH & Co. KG
D - 8399 Ruhstorf a. d. Rott
República Federal de Alemania
☎ (0 85 31) 319-1 — ☎ 57260

	Inhaltsverzeichnis	Index	Tafel No. Table No.
M . . .	Grundmotor	Basic engine	
00, 34	Ersatzteilsätze, Zubehör	Spare parts kits, accessories	01
01	Kurbelgehäuse	Crankcase	02
01	Kurbelgehäuse	Crankcase	03
02, 03	Kurbelwelle, Lagerflansch	Crankshaft, bearing flange	04
04	Nockenwelle	Camshaft	05
05, 06	Kolben, Pleuel, Zylinder	Piston, conrod, cylinder	06
07	Zylinderkopf	Cylinder head	07
07	Zylinderkopf	Cylinder head	08
09, 11	Stößstangen, Steuerdeckel	Pushrod, timing cover	09
14	Einspritzausrüstung	Injection equipment	10
17, 26	Schwungräder, Verschalung	Flywheels, cowling	11
A . . .	Zusatzausrüstungen	Equipments	
01	Kraftstoffbehälter	Fuel tank	12
01	Kraftstofffilter	Fuel filter	13
02	Luftfilter	Air filter	14
03	Abgasschalldämpfer	Exhaust silencer	15
04	Andrehkurbel, Andrehvorrichtung schs.	Starting handle, starting device flywheel side	16
05	Starter, Generator	Starter, alternator	17
05	Armaturen	Electric equipment	18
15, 16	Anschlußgehäuse, elast. Kupplung, Wellenstummel	Intermed. housing, flexible coupling stubshaft	19
18	Anbautelle Hydraulikpumpe	Mount. parts hydr. pump	20
	Zusatzausrüstungen	Equipements	Seite / Page 73 - 75
	Serien-Nr.-Änderungen	Serial-code modification list	76 - 80

	Sommaire	Indice	
M . . .	Moteur de base	Motor de base	
00, 34	Lots de pièces de rechange, accessoires	Juegos de piezas de recambios, accesorios	01
01	Carter moteur	Caja cigueñal	02
01	Carter moteur	Caja cigueñal	03
02, 03	Vilebrequin, palier	Cigueñal, brida de cojinete	04
04	Arbre à cames	Arbol de levas	05
05, 06	Piston, bielle, cylindre	Embolo, biela, cilindro	06
07	Culasse	Culata	07
07	Culasse	Culata	08
09, 11	Tige de culbuteur, couvercle distribution	Varilla de balancin, tapa de mando	09
14	Equipement d'injection	Equipo de inyección	10
17, 26	Volants, tole refroid.	Volantes, revestimiento	11
A . . .	Accessoires	Equipos	
01	Reservoir à carburant	Depósito combustible	12
01	Filtre à carburant	Filtro de combustible	13
02	Filtre à air	Filtro de aire	14
03	Silencieux	Silenciador	15
04	Manivelle, dispositif démarrage	Manivela, dispositivo de arranque	16
05	Demarreur, alternateur	Arrancador, alternador	17
05	Electrique equipement	Equipo eléctrico	18
15, 16	Bride intermediere, acçouplement elast. bout d'arbre	Caja de conexion, acoplamiento elast., eje	19
18	Pièces mont. pompe hydr.	Piezas mont. bomba hidraulica	20
			Page/Página No.
	Acessolres complementaires	Equipos	73 - 75
	Modification des Nos de serien	Modificación de los Nos de serie	76 - 80

M 00

Ersatzteilsätze
Spare parts kits
Lots de pièces de rechange
Juegos de piezas de recambios

M 34

Zubehör
Accessories
Accessoires
Accesorios

Tafel Nr.
Tabl. No.

01

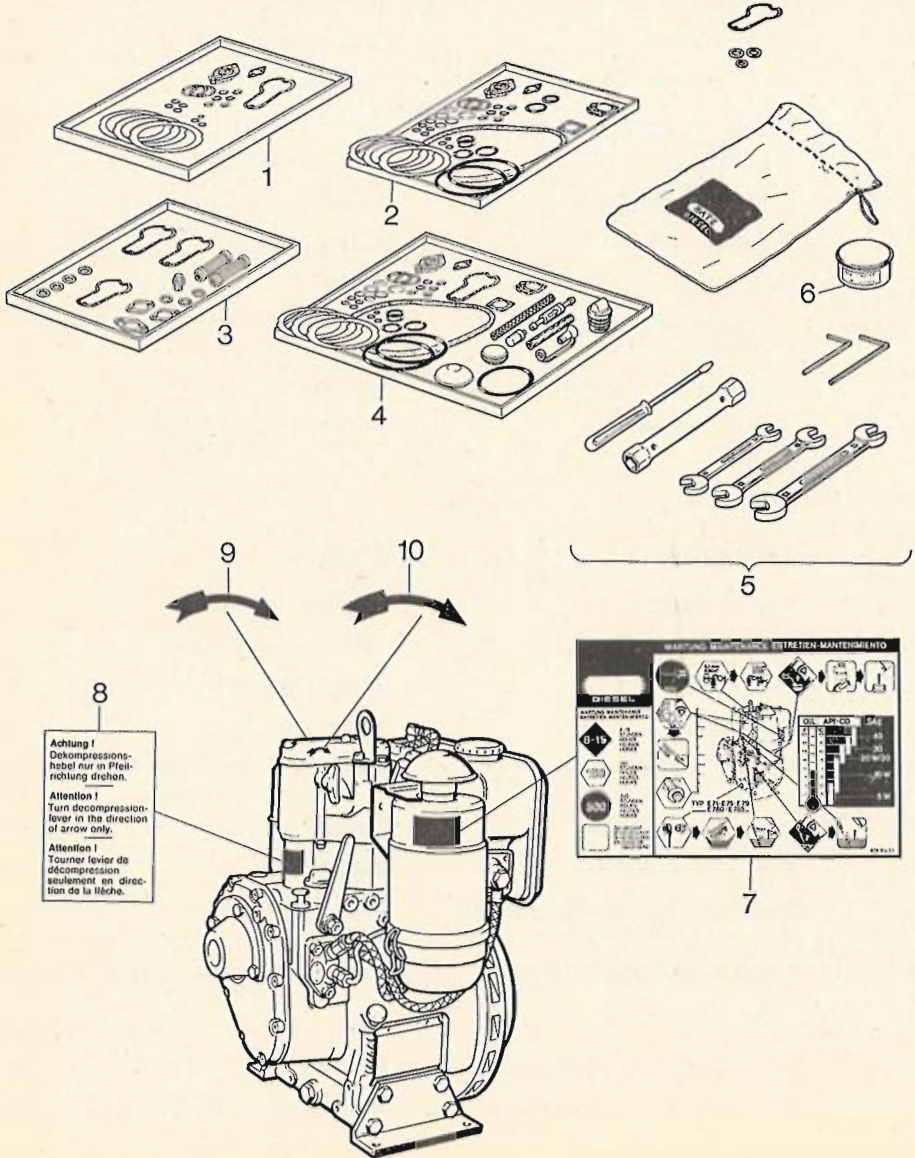

Fig. No.	Bestell-Nr.	Stück				Hinweise
	Ordering No.	Quantity				Hints
	No. référence	Quantites				Indications
	No. de pedido	Cantidades				Indicaciones

E 71 | E 75 | E 79 | E 780 | E 786

P: Im Pannensatz enthalten. — Incl. in emergency kit. — Contenu dans le jeu secur. — Contenido en el juego para averias.

W: Im Wartungssatz enthalten. — Nncl. in maintenance kit. — Contenu dans le jeu d'entretien. — Contenido en el juego de mantenimiento.

1: Anzahl pro Satz. —Qty. per kit. — Quantite par jeu. — Cantidad por juego.

1	003 394 10 P1	1	1	—	—	—	Dichtungssatz f. 1 Zylinderkopf
1	003 552 10 P1	—	—	1	1	—	Gasket set for 1 cyl. head
1	003 589 10 P1	—	—	—	—	1	Jeu de joint p. 1 culasse
							Juego de juntas para 1 culata
2	012 298 00	1	1	1	1	—	Dichtungssatz Kurbelgehäuse
2	012 299 00	—	—	—	—	1	Gasket set crankcase
							Jeu de joints carter moteur
							Juego de juntas caja cigueñal
3	009 613 01	1	1	1	1	—	Wartungssatz für 1000 h
3	009 614 01	—	—	—	—	1	1000 hours maintenance kit
							Kit d'entretien 1000 heures
							Juego de piezas para mantenimiento 1000 horas
4	009 657 03	1	1	—	—	—	Pannensatz
4	009 658 03	—	—	1	—	—	Emergency kit
4	009 659 03	—	—	—	1	—	Kit de secours
4	012 010 02	—	—	—	—	1	Juego para averias
5	004 317 00	1	1	1	1	—	Zubehörsatz
5	009 981 00	—	—	—	—	1	Accessories kit
6	400 370 00	1	1	1	1	—	Sort. accessoires
							Juego de accesorios
7	036 312 01	1	1	1	1	1	
8	033 963 01	1	1	1	1	1	
9	033 967 00	1	1	1	1	1	
10	035 890 00	1	1	1	1	1	

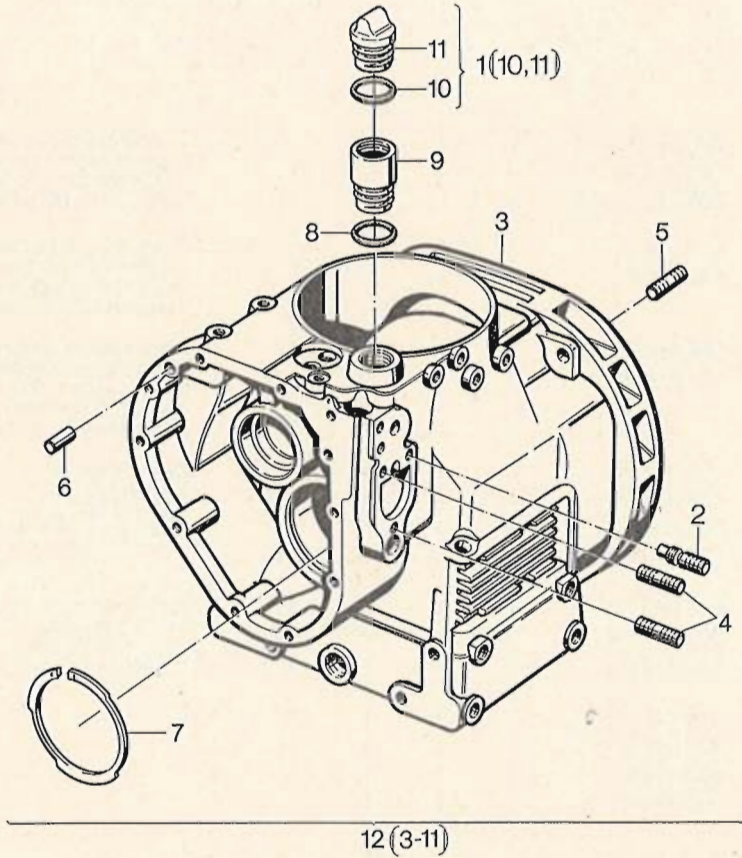

Fig. No.	Bestell-Nr. Ordering No. No. référence No. de pedido	Stück Quantity Quantites Cantidades					Hinweise Hints Indications Indicaciones	
		E 71	E 75	E 79	E 780	E 786		
1	006 321 01 W1	1	1	1	1	1		
2	037 746 00	1	1	1	1	1		
3	—	—	—	—	—	—		
4	500 377 00	2	2	2	2	2	M 8 x 20	DIN 939 - 5.6
5	500 373 00	6	6	6	10	10	M 8 x 18	DIN 835-10.9
6	031 693 00	1	1	1	1	1		
7	400 276 00	1	1	1	1	1		
8	501 538 00	1	1	1	1	1		
9	036 584 00	1	1	1	1	1		
10	501 538 00	1	1	1	1	1		
11	—	—	—	—	—	—		
12	003 554 02	1	1	1	—	—		
12	003 567 03	—	—	—	1	—		
12	003 591 02	—	—	—	—	1		

M 01

Kurbelgehäuse
Crankcase
Carter moteur
Caja cigüeñal

Tafel Nr.
Tabl. No.

03

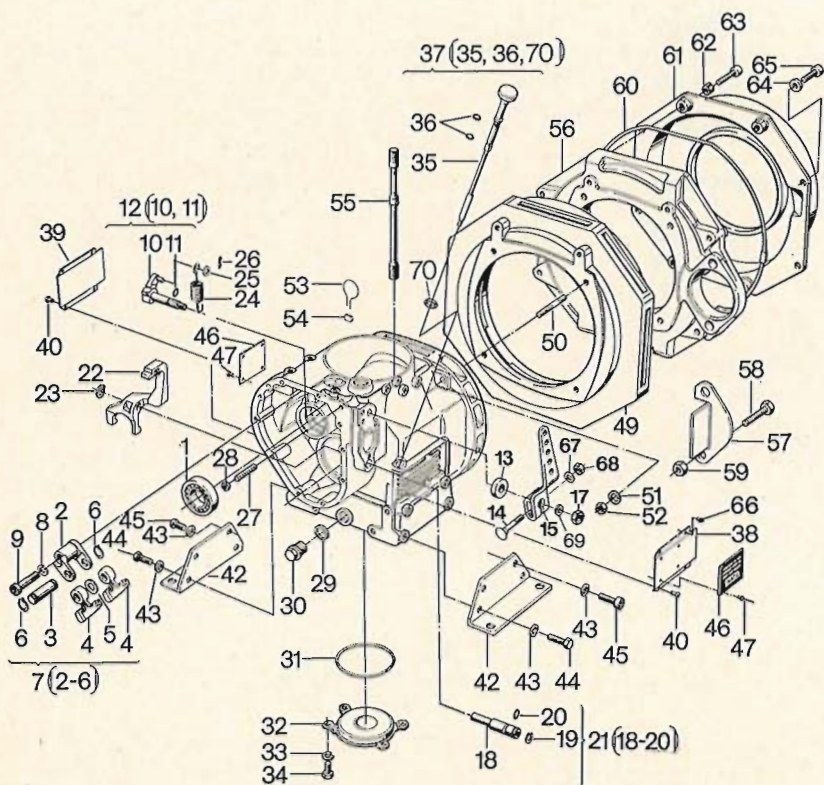

Fig. No.	Bestell-Nr. Ordering No. No. référence No. de pedido	Stück Quantity Quantities Cantidades					Hinweise Hints Indications Indicaciones	
		E 71	E 75	E 79	E 780	E 786		
1	500 142 00	1	1	1	1	1		
2	030 091 00	1	1	1	1	1		
3	031 688 00	1	1	1	1	1		
4	030 090 02	2	2	2	2	2		
5	031 694 00	0...1	0...1	0...1	0...1	0...1	0,1 mm	
5	031 696 00	0...1	0...1	0...1	0...1	0...1	0,2 mm	
5	031 697 00	0...1	0...1	0...1	0...1	0...1	0,3 mm	
5	031 698 00	0...1	0...1	0...1	0...1	0...1	0,5 mm	
6	500 195 00	2	2	2	2	2	12 x 1	DIN 471
7	003 396 00	1	1	1	1	1		
8	500 029 00	1	1	1	1	1	10	DIN 128
9	031 704 00	1	1	1	1	1		
10	—	—	—	—	—	—		
11	400 223 00	1	1	1	1	1		
12	003 002 00	1	1	1	1	1		
13	031 462 01	1	1	1	1	1		
14	039 273 00	1	1	1	1	1	M 6 x 32	
15	011 499 00	1	1	1	1	1		
16	—	—	—	—	—	—		
17	400 286 00	1	1	1	1	1	M 10	SSN 440-8 Cu
18	—	—	—	—	—	—		
19	400 310 00	1	1	1	1	1		
20	400 223 00	1	1	1	1	1		
21	005 579 00	1	1	1	1	1		
22	010 603 00	—	—	—	—	1	Federanschlag, spring stop, arrête de ressort	
22	030 084 05	1	1	1	1	—		
23	500 194 00	1	1	1	1	1	8 x 0,8	DIN 471
24	031 949 02	1	1	1	1	—	2,1 mm ϕ	$\leq 2100 \text{ min}^{-1}$
24	037 708 00	—	—	—	—	1	2,0 mm ϕ	$\leq 2100 \text{ min}^{-1}$
24	037 699 00	—	—	—	—	1	2,4 mm ϕ	$> 2100 \text{ min}^{-1}$
24	031 948 01	1	1	1	1	—	2,6 mm ϕ	$> 2100 \text{ min}^{-1}$
25	031 332 00	1	1	1	1	1		
26	500 361 00	1	1	1	1	1	2 x 22	DIN 94
27	031 695 01	1	1	1	1	1		
28	500 232 00	1	1	1	1	1	BM 8	DIN 439 - 5
29	500 015 00 W7	1	1	1	1	1	A 21 x 26	DIN 7603-Cu
30	031 691 03 W1	1	1	1	1	1		
31	502 229 00	1	1	1	1	1		
32	030 032 01	1	1	1	1	1		

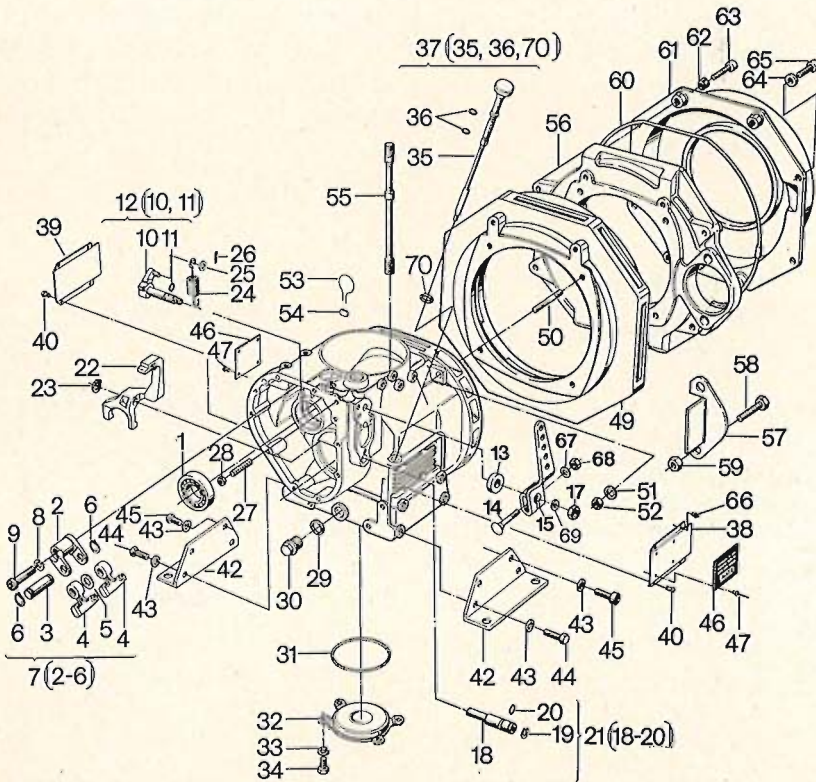

Fig. No.	Bestell-Nr. Ordering No. No. référence No. de pedido	Stück Quantity Quantities Cantidades					Hinweise Hints Indications Indicaciones	
		E 71	E 75	E 79	E 780	E 786		
33	500 028 00	4	4	4	4	4	8	DIN 128
34	500 267 00	4	4	4	4	4	M 8 x 16	DIN 933 - 8.8
35	—	—	—	—	—	—		
36	400 217 00	2	2	2	2	2		
37	003 071 02	1	1	1	1	1		
37	010 698 00	1	1	1	1	1	$n \leq 1500 \text{ min}^{-1}$ Taf./Tabl. 06, Pos. 18-21	
38	031 690 00	1	1	1	1	1		
39	031 692 00	1	1	1	1	1		
40	500 055 00	8	8	8	8	6	3 x 12	DIN 1476
42	030 075 00	2	2	2	—	—		
42	030 165 00	—	—	—	2	2		
43	500 029 00	8	8	8	8	8	10	DIN 128
44	500 293 00	8	8	8	—	—	M 10 x 30	DIN 933 - 8.8
45	500 541 00	—	—	—	8	8	M 10 x 30	DIN 912 - 8.8
46	032 255 03	1	1	1	1	1		
47	400 025 00	4	4	4	4	4		
49	032 008 03	—	—	—	—	1		
50	500 408 00	—	—	—	4	4	M 10 x 28	DIN 939-10.8
51	500 169 00	—	—	—	4	4	B 10,5	DIN 125 - St
52	500 235 00	—	—	—	4	4	M 10	DIN 934 - 8
53	400 215 00	1	1	1	1	1		
54	400 214 00	1	1	1	1	1		
55	031 716 00	4	4	4	—	—		
55	032 001 00	—	—	—	4	—		
55	032 031 01	—	—	—	—	4		
56	036 632 00	—	—	—	1	—		
57	036 634 00	—	—	—	1	—		
58	500 314 00	—	—	—	2	—	M 12 x 40	DIN 933 - 8.8
59	500 239 00	—	—	—	2	—	M 12	DIN 934 - 8
60	036 630 00	—	—	—	1	—		
60	036 156 00	1	1	1	—	—		
61	036 843 00	—	—	—	1	—		
62	036 845 00	—	—	—	4	—		
63	500 538 00	—	—	—	4	—	M 10 x 25	DIN 912 - 8.8
64	036 844 00	—	—	—	4	—		
65	500 522 00	—	—	—	4	—	M 8 x 30	DIN 912 - 8.8
66	500 183 00	—	—	—	—	2	3 x 12	DIN 1477
67	501 445 00	1	1	1	1	1	6,4	DIN 125 A3C
68	503 465 00	1	1	1	1	1	M 6	DIN 934-8 10.9
69	500 172 00	1	1	1	1	1	13	DIN 125-St
70	503 244 00	1	1	1	1	1		

M 02

Kurbelwelle
Crankshaft
Vilebrequin
Cigüeñal

M 03

Lagerflansch
Bearing flange
Palier
Brida de cojinete

Tafel Nr.
Tabl. No.

04

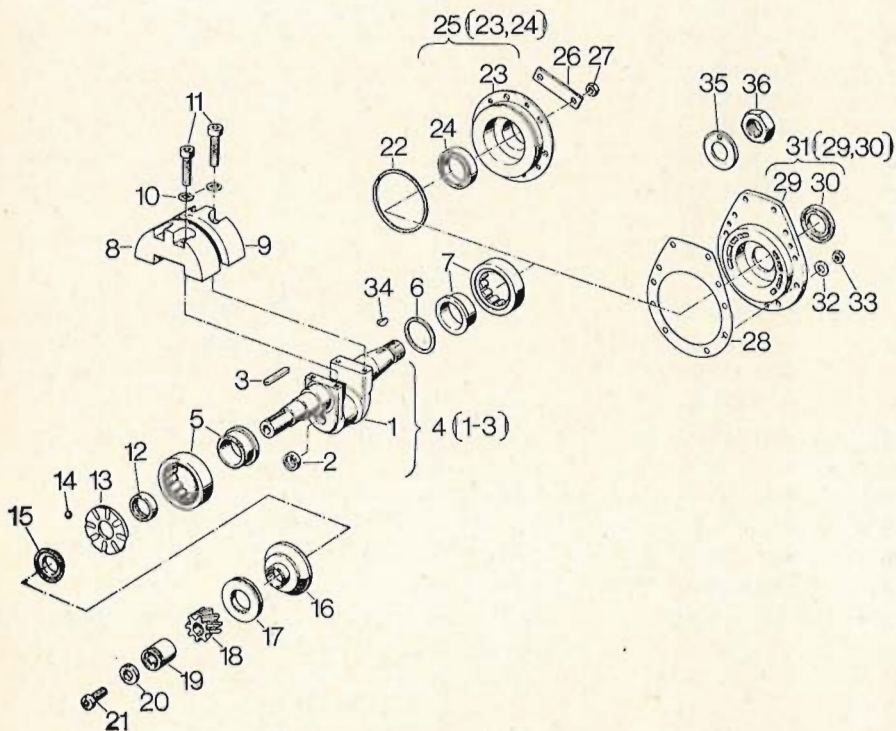

Fig. No.	Bestell-Nr. Ordering No. No. référence No. de pedido	Stück Quantity Quantites Cantidades					Hinweise Hints Indications Indicaciones
		E 71	E 75	E 79	E 780	E 786	
1	—	—	—	—	—	—	
2	031 950 00	1	1	1	1	—	
2	032 010 00	—	—	—	—	1	
3	031 951 00	1	1	1	1	1	
4	003 555 03	1	1	1	—	—	
4	003 568 02	—	—	—	1	—	
4	003 593 01	—	—	—	—	1	
5	500 479 00	1	1	1	1	1	
6	031 952 00	0...1	0...1	0...1	—	—	0,10 mm
6	031 953 00	0...1	0...1	0...1	—	—	0,20 mm
6	031 954 00	0...1	0...1	0...1	—	—	0,30 mm
6	031 955 00	0...1	0...1	0...1	—	—	0,40 mm
6	031 956 00	0...1	0...1	0...1	—	—	0,50 mm
6	031 987 00	—	—	—	0...1	—	0,10 mm
6	031 988 00	—	—	—	0...1	—	0,20 mm
6	031 989 00	—	—	—	0...1	—	0,30 mm
6	031 990 00	—	—	—	0...1	—	0,40 mm
6	031 991 00	—	—	—	0...1	—	0,50 mm
6	032 011 00	—	—	—	—	0...1	0,10 mm
6	032 012 00	—	—	—	—	0...1	0,20 mm
6	032 013 00	—	—	—	—	0...1	0,30 mm
6	032 014 00	—	—	—	—	0...1	0,40 mm
6	032 015 00	—	—	—	—	0...1	0,50 mm
7	500 479 00	1	1	1	—	—	
7	500 481 00	—	—	—	1	—	
7	500 483 00	—	—	—	—	1	
8	030 131 02	1	1	1	—	—	
8	030 152 01	—	—	—	1	—	
8	030 186 00	—	—	—	—	1	
9	034 370 00	1	1	—	—	—	
9	030 132 02	—	—	1	—	—	
9	030 153 01	—	—	—	1	—	
9	030 187 00	—	—	—	—	1	
10	500 029 00	4	4	4	4	4	10 DIN 128
11	500 550 00	4	4	4	4	—	M 10 x 50 DIN 912-10.9

M 02

Kurbelwelle
Crankshaft
Vilebrequin
Cigüeñal

M 03

Lagerflansch
Bearing flange
Palier
Brida de cojinete

Tafel Nr.
Tabl. No.

04

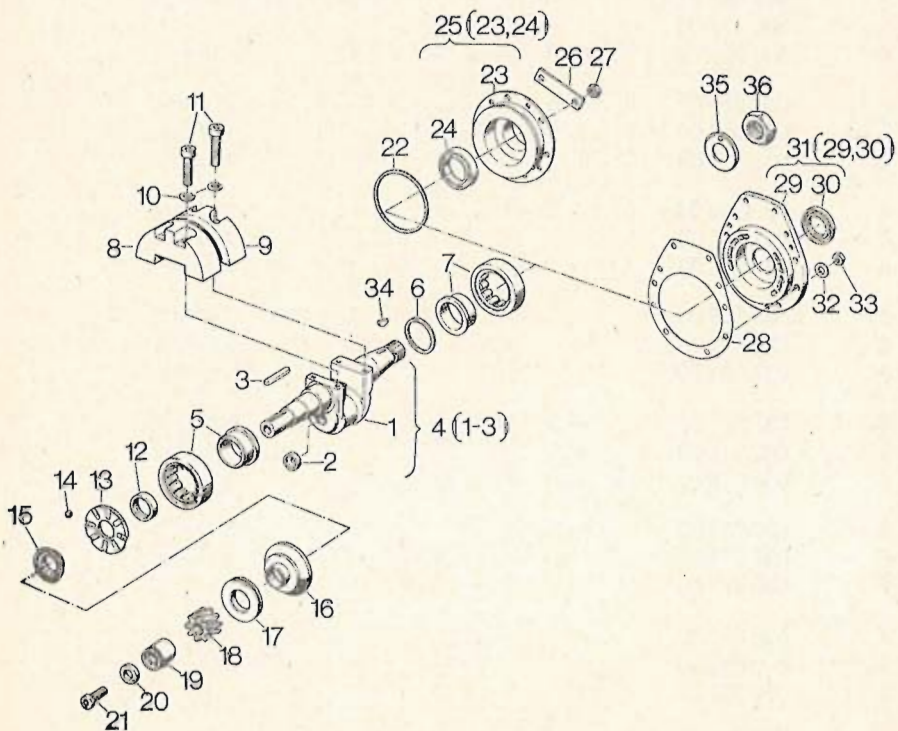

Fig. No.	Bestell-Nr. Ordering No. No. référence No. de pedido	Quantity Stück Quantites Cantidades					Hinweise Hints Indications Indicaciones	
		E 71	E 75	E 79	E 780	E 786		
11	500 553 00	—	—	—	—	4	M 10 x 60	DIN 912-10.9
12	030 130 00	1	1	1	1	1		
13	030 066 02	1	1	1	1	1		
14	500 100 00	8	8	8	8	8		
15	031 700 01	1	1	1	1	1		
16	007 420 00	1	1	1	1	—		
16	012 132 00	—	—	—	—	1		
17	030 045 01	1	1	1	1	1		
18	030 010 01	1	1	1	1	1		
19	030 016 01	1	1	1	1	1	E	
20	031 699 01	1	1	1	1	1	E	
21	500 576 00	1	1	1	1	1	M 12x1,5x28	DIN 6912-10.9
22	502 229 00	1	1	1	—	—		
23	—	—	—	—	—	—		
24	400 339 00	1	1	1	—	—		
25	003 398 02	1	1	1	—	—		
26	032 799 00	3	3	3	—	—		
27	500 229 00	6	6	6	—	—	M 8	DIN 934 - 8
28	031 992 00	—	—	—	1	1		
29	—	—	—	—	—	—		
30	400 339 00	—	—	—	1	—		
30	400 341 00	—	—	—	—	1		
31	003 570 00	—	—	—	1	—		
31	003 594 00	—	—	—	—	1		
32	031 701 00	—	—	—	10	10		
33	500 229 00	—	—	—	10	10	M 8	DIN 934 - 8
34	500 178 00	1	1	1	1	—	4 x 6,5	DIN 6888
34	500 181 00	—	—	—	—	1	8 x 11	DIN 6888
35	031 986 00	1	1	1	1	—		
35	032 009 00	—	—	—	—	1		
36	032 855 00	1	1	1	1	—		
36	032 854 00	—	—	—	—	1		

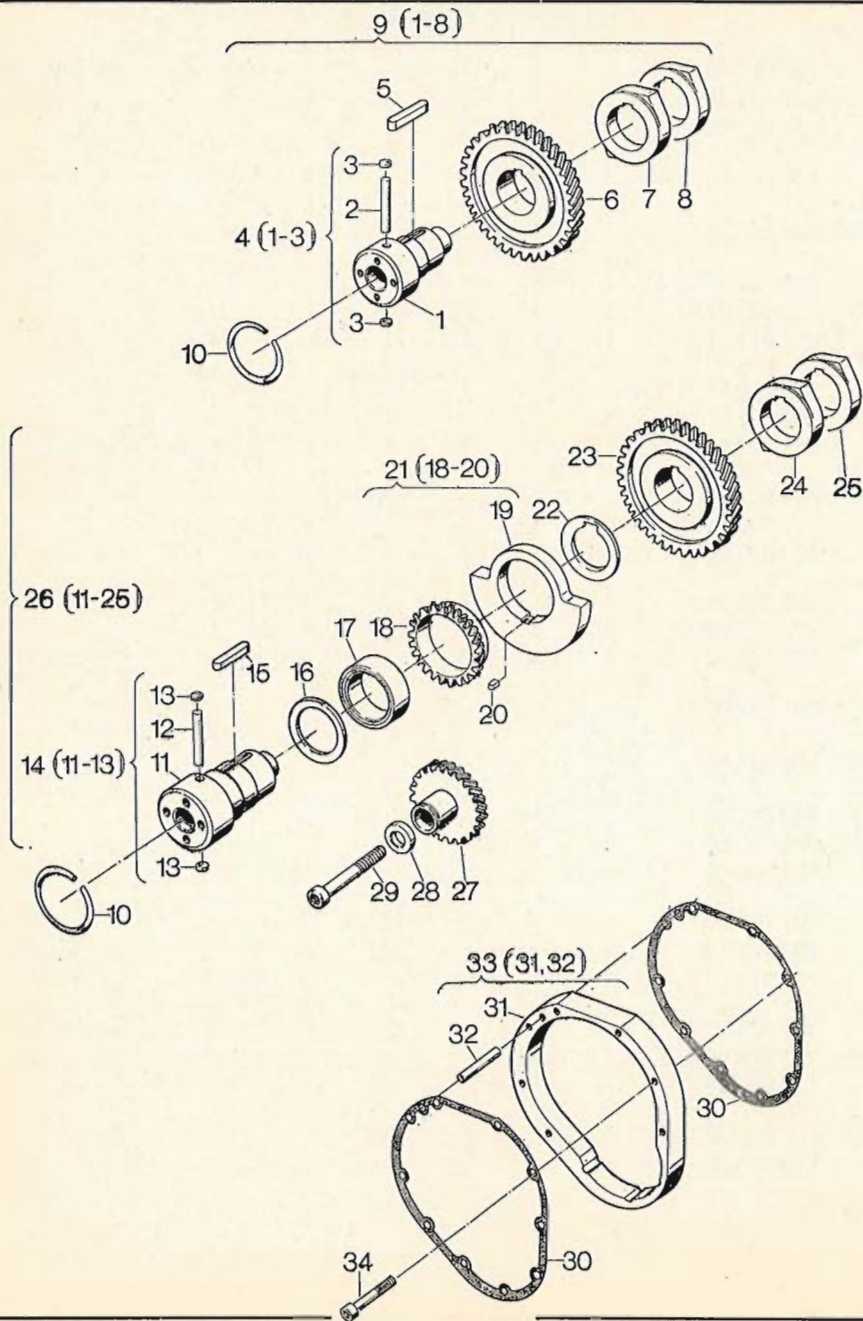

Fig. No.	Bestell-Nr.	Stück					Hinweise	
	Ordering No.	Quantity					Hints	
	No. référence	Quantités					Indications	
	No. de pedido	Cantidades					Indicaciones	
		E 71	E 75	E 79	E 780	E 786		
1	—	—	—	—	—	—		
2	030 126 00	1	1	1	1	1		
3	500 433 00	2	2	2	2	2	8	DIN 470
4	004 233 04	1	1	1	1	1		
5	500 116 00	1	1	1	1	1	A 8 x 7 x 56	DIN 6885
6	030 009 02	1	1	1	1	1		
7	030 083 05	1	1	1	1	1		
8	030 082 03	1	1	1	1	1		
9	003 400 02	1	1	1	1	1		
10	031 703 00	1	1	1	1	1		
11	—	—	—	—	—	—		
12	030 126 00	—	—	—	1	1		
13	500 433 00	—	—	—	2	2	8	DIN 470
14	005 145 00	—	—	—	1	1	U	
15	500 116 00	—	—	—	1	1	A 8 x 7 x 56	DIN 6885
16	032 565 00	—	—	—	1	1	U	
17	400 196 00	—	—	—	1	1	U	
18	—	—	—	—	—	—		
19	—	—	—	—	—	—		
20	501 704 00	—	—	—	1	1	U	A 6x4x12 DIN 6885
21	003 129 00	—	—	—	1	—	U	
21	003 127 00	—	—	—	—	1	U	
22	032 016 00	—	—	—	1	1	U	
23	030 009 02	—	—	—	1	1		
24	030 083 05	—	—	—	1	1		
25	030 082 03	—	—	—	1	1		
26	003 571 02	—	—	—	1	—	U	
26	003 595 02	—	—	—	—	1	U	
27	031 000 01	—	—	—	1	1	U	
28	031 699 01	1	1	1	1	1		
29	400 922 00	—	—	—	1	1	U	
30	031 745 00	—	—	—	2	2	U	
31	—	—	—	—	—	—		
32	500 586 00	—	—	—	1	1	8 m 6 x 50	DIN 7-9S20 k
33	004 096 00	—	—	—	1	1	U	
34	500 527 00	—	—	—	10	10	U	M 8 x 50 DIN 912 - 8.8

M 05

Kolben, Pleuel
Piston, conrod
Piston, bielle
Embolo, biela

M 06

Zylinder
Cylinder
Cylindre
Cilindro

Tafel Nr.
Tabl. No.

06

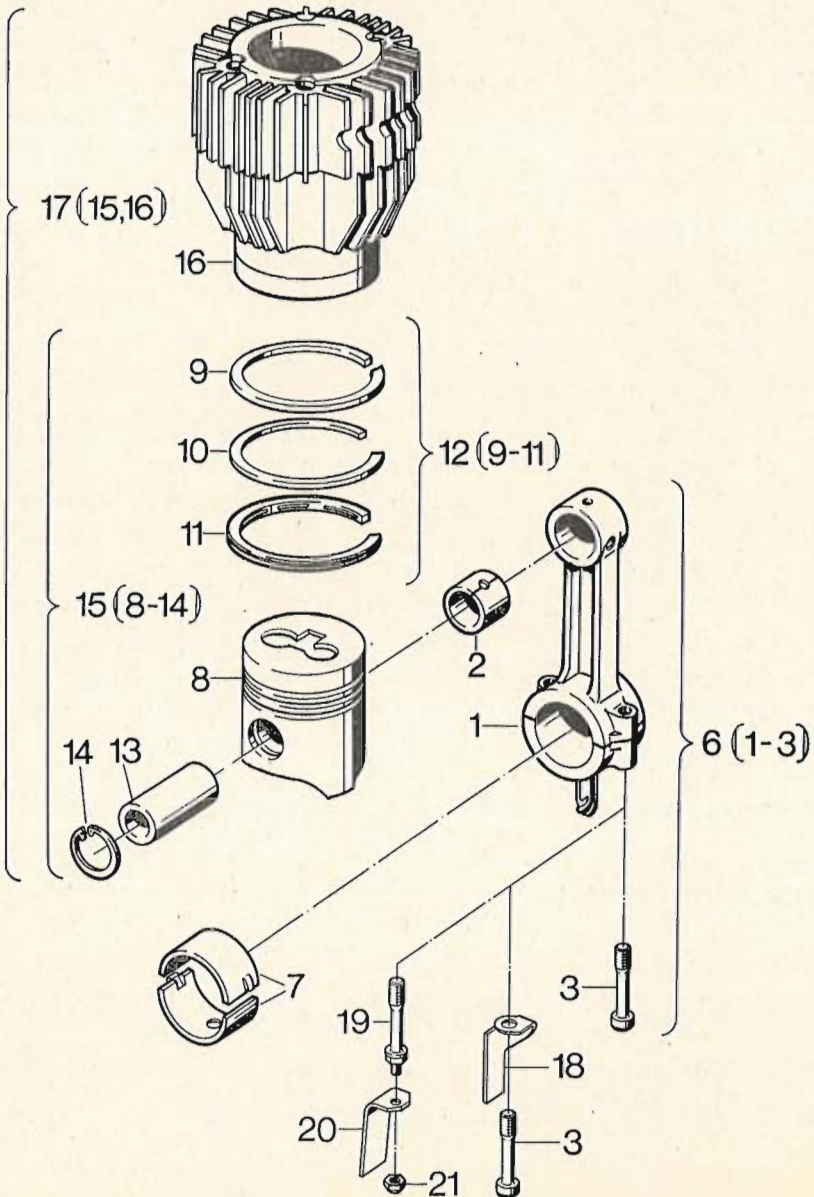

Fig. No.	Bestell-Nr. Ordering No. No. référence No. de pedido	Stück Quantity Quantités Cantidades					Hinweise Hints Indications Indicaciones
		E 71	E 75	E 79	E 780	E 786	
1	—	—	—	—	—	—	
2	030 030 01	1	1	—	—	—	
2	030 128 00	—	—	1	1	—	
2	032 020 00	—	—	—	—	1	
3	031 704 00	2	2	2	2	2	
4	—	—	—	—	—	—	
5	—	—	—	—	—	—	
6	003 403 00	1	1	—	—	—	
6	003 559 00	—	—	1	—	—	
6	003 574 00	—	—	—	1	—	
6	003 598 00	—	—	—	—	1	
7	031 957 00	1	1	1	1	—	
7	031 958 00	1	1	1	1	—	— 0,5 mm
7	032 018 00	—	—	—	—	1	
7	032 019 00	—	—	—	—	1	— 0,5 mm
8	—	—	—	—	—	—	
9	—	—	—	—	—	—	
10	—	—	—	—	—	—	
11	—	—	—	—	—	—	
12	005 714 10	1	1	—	—	—	
12	012 342 00	1	1	—	—	—	+ 0,5 mm
12	005 715 10	1	1	—	—	—	+ 1,0 mm
12	005 730 10	—	—	1	—	—	
12	012 344 00	—	—	1	—	—	+ 0,5 mm
12	005 731 10	—	—	1	—	—	+ 1,0 mm
12	005 732 02	—	—	—	1	—	
12	012 346 00	—	—	—	1	—	+ 0,5 mm
12	005 733 02	—	—	—	1	—	+ 1,0 mm
12	005 708 11	—	—	—	—	1	
12	012 348 00	—	—	—	—	1	+ 0,5 mm
12	005 709 11	—	—	—	—	1	+ 1,0 mm
13	501 018 00	1	1	—	—	—	
13	501 082 00	—	—	1	1	—	
13	501 064 00	—	—	—	—	1	
14	500 206 00	2	2	—	—	—	25 x 1,2 DIN 472
14	500 207 00	—	—	2	2	—	28 x 1,2 DIN 472

M 05

Kolben, Pleuel
Piston, conrod
Piston, bielle
Embolo, biela

M 06

Zylinder
Cylinder
Cylindre
Cilindro

Tafel Nr.
Tabl. No.

06

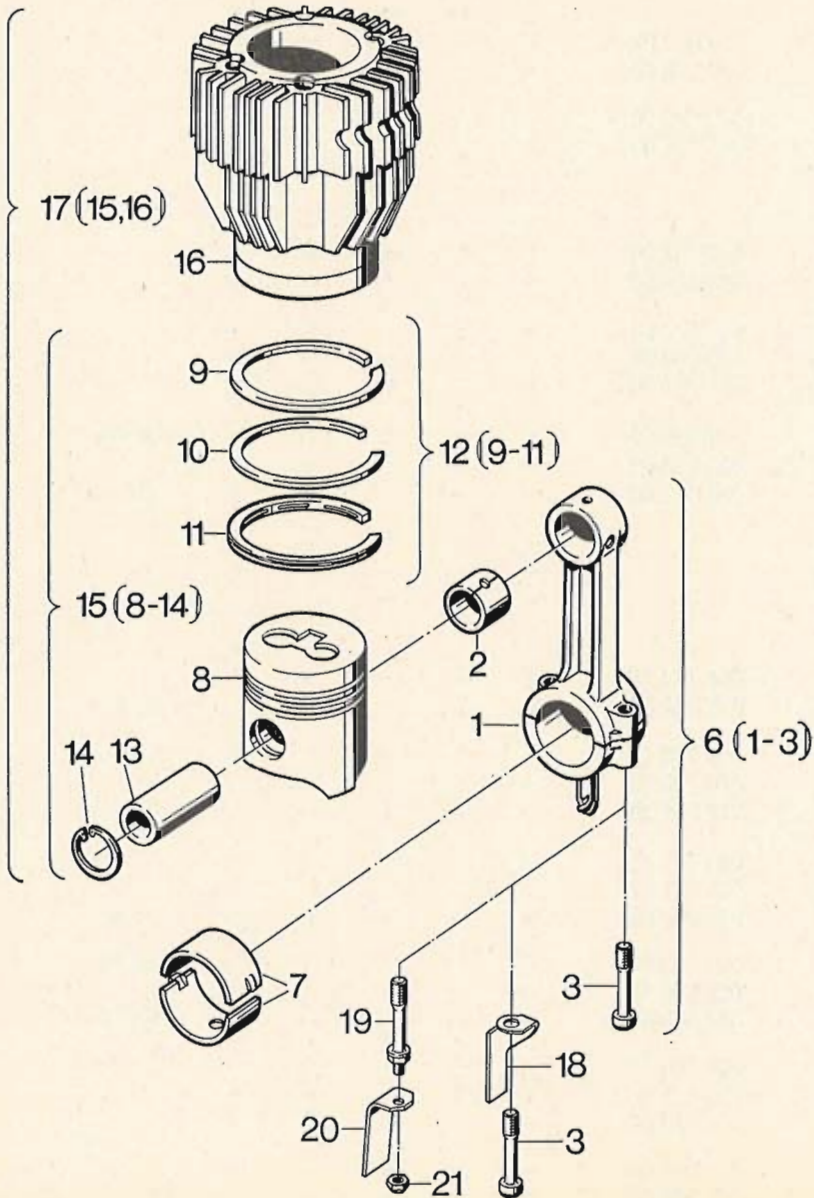

Fig. No.	Bestell-Nr. Ordering No. No. référence No. de pedido	Stück Quantity Quantites Cantidades					Hinweise Hints Indications Indicaciones
		E 71	E 75	E 79	E 780	E 786	
14	500 208 00	—	—	—	—	2	30 x 1,2 DIN 472
15	003 401 04	1	1	—	—	—	
15	012 341 00	1	1	—	—	—	+ 0,5 mm
15	003 402 04	1	1	—	—	—	+ 1,0 mm
15	003 560 01	—	—	1	—	—	
15	012 343 00	—	—	1	—	—	+ 0,5 mm
15	003 561 01	—	—	1	—	—	+ 1,0 mm
15	003 572 02	—	—	—	1	—	
15	012 345 00	—	—	—	1	—	+ 0,5 mm
15	003 573 02	—	—	—	1	—	+ 1,0 mm
15	009 971 00	—	—	—	—	1	
15	012 347 00	—	—	—	—	1	+ 0,5 mm
15	009 972 00	—	—	—	—	1	+ 1,0 mm
16	—	—	—	—	—	—	
17	005 657 00	1	1	—	—	—	
17	005 661 00	—	—	1	—	—	
17	005 662 00	—	—	—	1	—	
17	012 004 00	—	—	—	—	1	
18	037 733 01	1	1	1	—	—	$n \leq 1500 \text{ min}^{-1}$
18	037 793 00	—	—	—	1	—	$n \leq 1800 \text{ min}^{-1}$
19	037 860 00	—	—	—	—	1	} $n \leq 1500 \text{ min}^{-1}$ s. Taf./Tabl. 03, Pos. 37
20	037 862 00	—	—	—	—	1	
21	037 861 00	—	—	—	—	1	

M 07

Zylinderkopf
Cylinder head
Culasse
Culata

Tafel Nr.
Tabl. No.

07

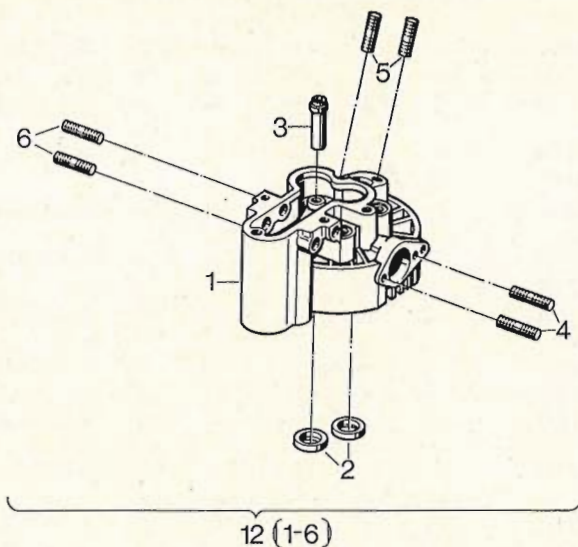

11 (3-10)

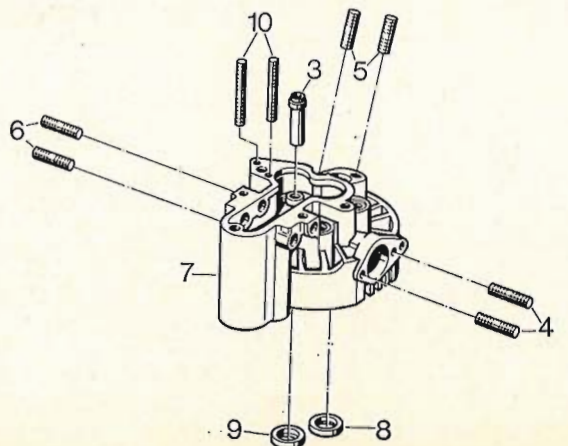

Fig. No.	Bestell-Nr. Ordering No. No. référence No. de pedido	Stück Quantity Quantities Cantidades					Hinweise Hints Indications Indicaciones	
		E 71	E 75	E 79	E 780	E 786		
1	—	—	—	—	—	—		
2	—	—	—	—	—	—		
3	031 723 10	2	2	2	2	—		
3	032 034 00	—	—	—	—	2		
4	500 373 00	2	2	2	2	—	M 8 x 18	DIN 835-10.9
4	502 851 00	—	—	2	2	—	M 8 x 25	DIN 835-10.9
4	500 403 00	—	—	—	—	2	M 10 x 22	DIN 939-5.6
5	500 383 00	2	2	2	2	—	M 8 x 30	DIN 835-5.8
5	500 385 00	—	—	—	—	2	M 8 x 40	DIN 835-5.8
6	500 378 00	2	2	2	2	—	M 8 x 22	DIN 835-10.9
6	500 403 00	—	—	—	—	2	M 10 x 22	DIN 939-5.6
7	—	—	—	—	—	—		
8	—	—	—	—	—	—		
9	—	—	—	—	—	—		
10	500 369 00	—	—	2	2	2	M 6 x 30	DIN 835-5.8
11	003 022 11	—	—	1	—	—		
11	003 005 11	—	—	—	1	—		
11	012 008 01	—	—	—	—	1		
12	003 020 10	1	—	—	—	—		
12	003 018 10	—	1	—	—	—		

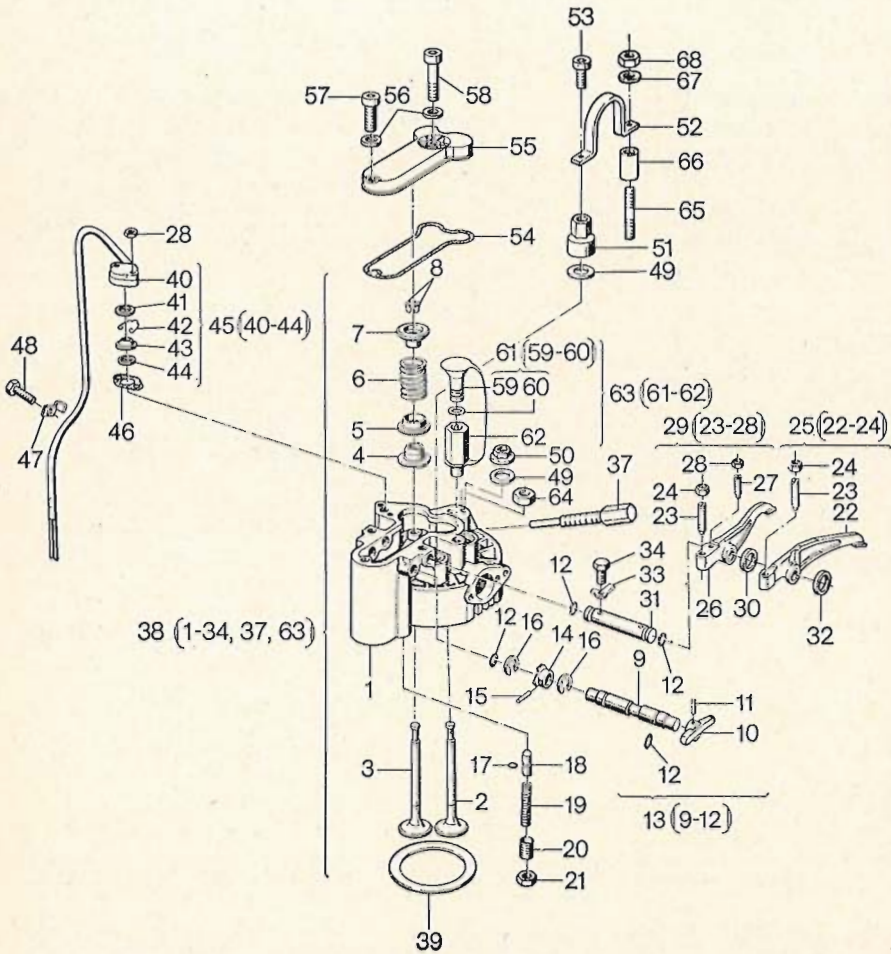

Fig. No.	Bestell-Nr. Ordering No. No. référence No. de pedido	Stück Quantity Quantites Cantidades					Hinweise Hints Indications Indicaciones	
		E 71	E 75	E 79	E 780	E 786		
1	003 020 10	1	—	—	—	—		
1	003 018 10	—	1	—	—	—		
1	003 022 10	—	—	1	—	—		
1	003 005 10	—	—	—	1	—		
1	012 008 01	—	—	—	—	1		
2	031 243 10	1	1	1	1	—		
2	037 659 00	—	—	—	—	1		
3	031 243 10	1	1	1	1	—		
3	030 199 10	—	—	—	—	1		
4	031 724 00	2	2	2	2	—		
4	032 032 00	—	—	—	—	2		
5	031 730 00	2	2	2	2	—		
5	032 033 00	—	—	—	—	2		
6	031 720 00	2	2	2	2	—		
6	031 587 01	—	—	—	—	2		
7	030 040 10	2	2	2	2	—		
7	030 185 10	—	—	—	—	2		
8	031 719 10	2	2	2	2	—		
8	036 209 00	—	—	—	—	2		
9	—	—	—	—	—	—		
10	031 734 01	1	1	1	1	1		
11	500 346 00	1	1	1	1	1	4 x 18	DIN 1481
12	400 223 00	4	4	4	4	4		
13	003 408 00	1	1	1	1	1		
14	030 008 01	1	1	1	1	1		
15	500 341 00	1	1	1	1	1	3 x 16	DIN 1481
16	400 502 00	2	2	2	2	2		
17	501 542 00	1	1	1	1	1		
18	030 103 00	1	1	1	1	1		
19	031 728 01	1	1	1	1	1		
20	500 050 00	1	1	1	1	—	AM 10 x 25	DIN 913-45 H
20	500 052 00	—	—	—	—	1	AM 10 x 35	DIN 913-45H
21	500 235 00	1	1	1	1	1	M 10	DIN 934 - 8

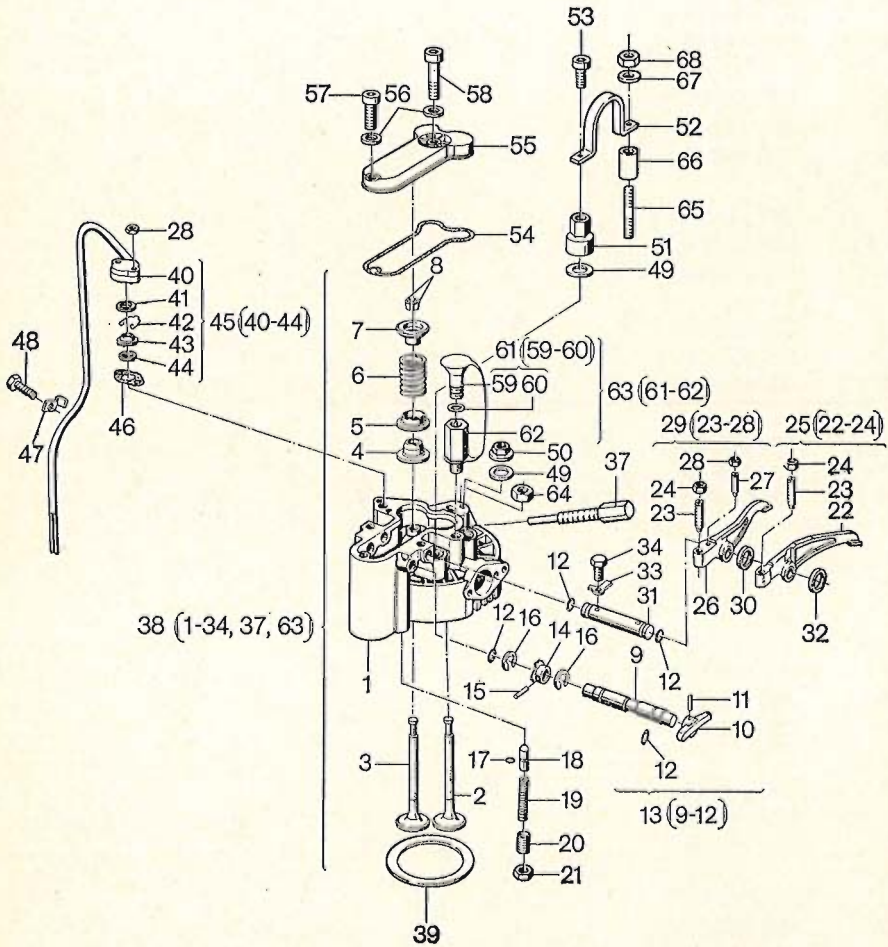

Fig. No.	Bestell-Nr. Ordering No. No. référence No. de pedido	Stück Quantity Cantidades Quantites					Hinweise Hints Indications Indicaciones	
		E 71	E 75	E 79	E 780	E 786		
22	—	—	—	—	—	—		
23	030 037 00	2	2	2	2	2		
24	031 731 00W2	2	2	2	2	2		
25	003 405 03	1	1	1	1	1		
26	—	—	—	—	—	—		
27	030 220 01	1	1	1	1	1		
28	500 227 00 P2	—	—	2	2	2	M 6	DIN 934 - 8
29	003 406 04	1	1	1	1	1		
30	030 344 01	—	—	—	—	0...1	4,0 mm	
30	034 053 00	—	—	—	—	0...1	4,1 mm	
30	034 007 00	—	—	—	—	0...1	4,2 mm	
30	034 008 00	—	—	—	—	0...1	4,3 mm	
31	031 721 00	1	1	1	1	1		
32	031 694 00	0...1	0...1	0...1	0...1	0...1	0,10 mm	
32	031 696 00	0...1	0...1	0...1	0...1	0...1	0,20 mm	
32	031 697 00	0...1	0...1	0...1	0...1	0...1	0,30 mm	
32	031 698 00	0...1	0...1	0...1	0...1	0...1	0,50 mm	
33	500 187 00	2	2	2	2	2	6,4	DIN 463 - St
34	500 255 00	2	2	2	2	—	M 6 x 12	DIN 933 - 8.8
34	500 257 00	—	—	—	—	2	M 6 x 16	DIN 933 - 8.8
37	030 115 00	1	1	1	1	—		
38	004 129 01	1	—	—	—	—		
38	004 125 03	—	1	—	—	—		
38	004 130 03	—	—	1	—	—		
38	004 131 01	—	—	—	1	—		
38	009 973 01	—	—	—	—	1		
39	031 722 00	0...1	0...1	—	—	—	0,40 mm	
39	031 735 00	0...1	0...1	—	—	—	0,50 mm	
39	031 736 00	0...1	0...1	—	—	—	0,60 mm	
39	031 737 00	0...1	0...1	—	—	—	0,70 mm	
39	031 738 00	0...1	0...1	—	—	—	0,80 mm	
39	031 739 00	0...1	0...1	—	—	—	0,90 mm	
39	031 740 00	0...1	0...1	—	—	—	1,00 mm	

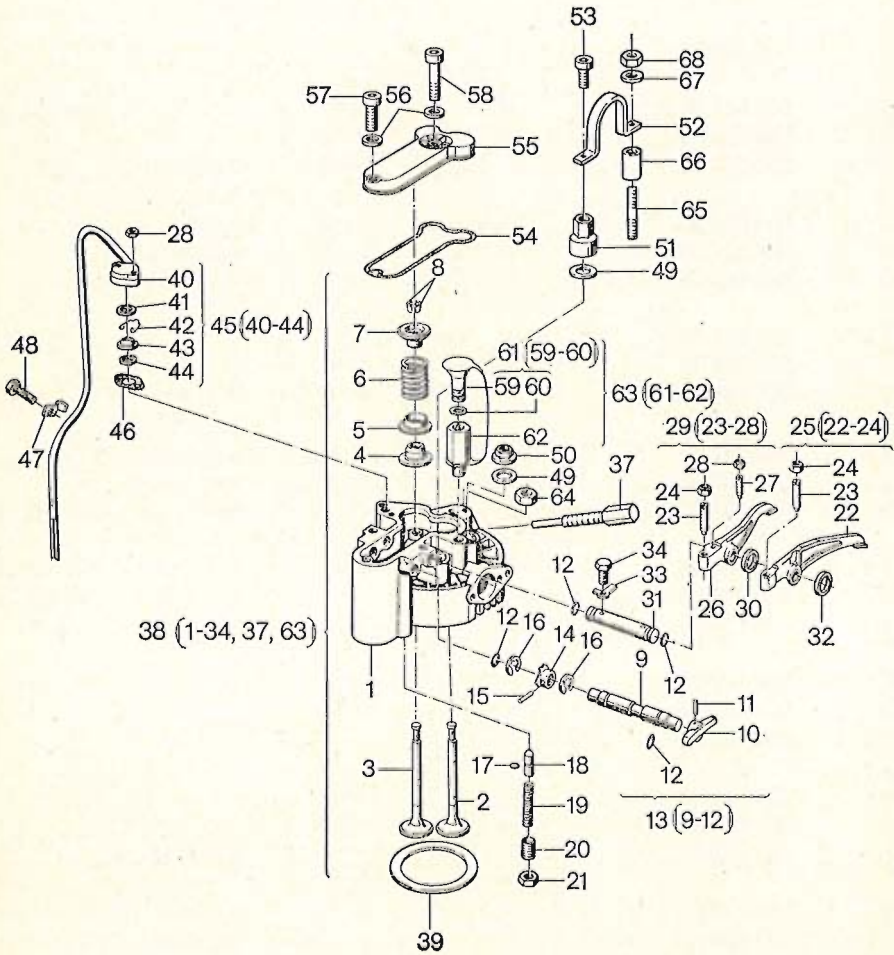

Fig. No.	Bestell-Nr. Ordering No. No. référence No. de pedido	Stück Quantity Quantites Cantidades					Hinweise Hints Indications Indicaciones
		E 71	E 75	E 79	E 780	E 786	
39	031 973 00	—	—	0...1	0...1	—	0,40 mm
39	031 974 00	—	—	0...1	0...1	—	0,50 mm
39	031 975 00	—	—	0...1	0...1	—	0,60 mm
39	031 976 00	—	—	0...1	0...1	—	0,70 mm
39	031 977 00	—	—	0...1	0...1	—	0,80 mm
39	031 978 00	—	—	0...1	0...1	—	0,90 mm
39	031 979 00	—	—	0...1	0...1	—	1,00 mm
39	032 035 00	—	—	—	—	0...1	0,40 mm
39	032 036 00	—	—	—	—	0...1	0,50 mm
39	032 037 00	—	—	—	—	0...1	0,60 mm
39	032 038 00	—	—	—	—	0...1	0,70 mm
39	032 039 00	—	—	—	—	0...1	0,80 mm
39	032 040 00	—	—	—	—	0...1	0,90 mm
39	032 041 00	—	—	—	—	0...1	1,00 mm
40	—	—	—	—	—	—	
41	034 443 00	—	—	1	1	1	
42	031 727 00	—	—	1	1	1	
43	031 725 00	—	—	1	1	1	
44	031 726 00	—	—	1	1	1	
45	003 563 01	—	—	1	—	—	
45	003 576 01	—	—	—	1	—	
45	003 600 01	—	—	—	—	1	
46	031 729 00	—	—	1	1	1	
47	031 972 00	—	—	1	—	—	
47	030 166 00	—	—	—	1	1	
48	500 267 00	—	—	1	1	1	M 8 x 16
49	031 717 00 P4	4	4	4	4	4	DIN 933-8.8
50	031 718 00 P2	2	2	2	2	—	
50	031 830 00 P2	—	—	—	—	2	
51	034 580 00 P2	2	2	2	2	—	
51	031 873 01 P2	—	—	—	—	2	
52	037 569 00	1	1	1	1	—	
52	037 568 00	—	—	—	—	1	

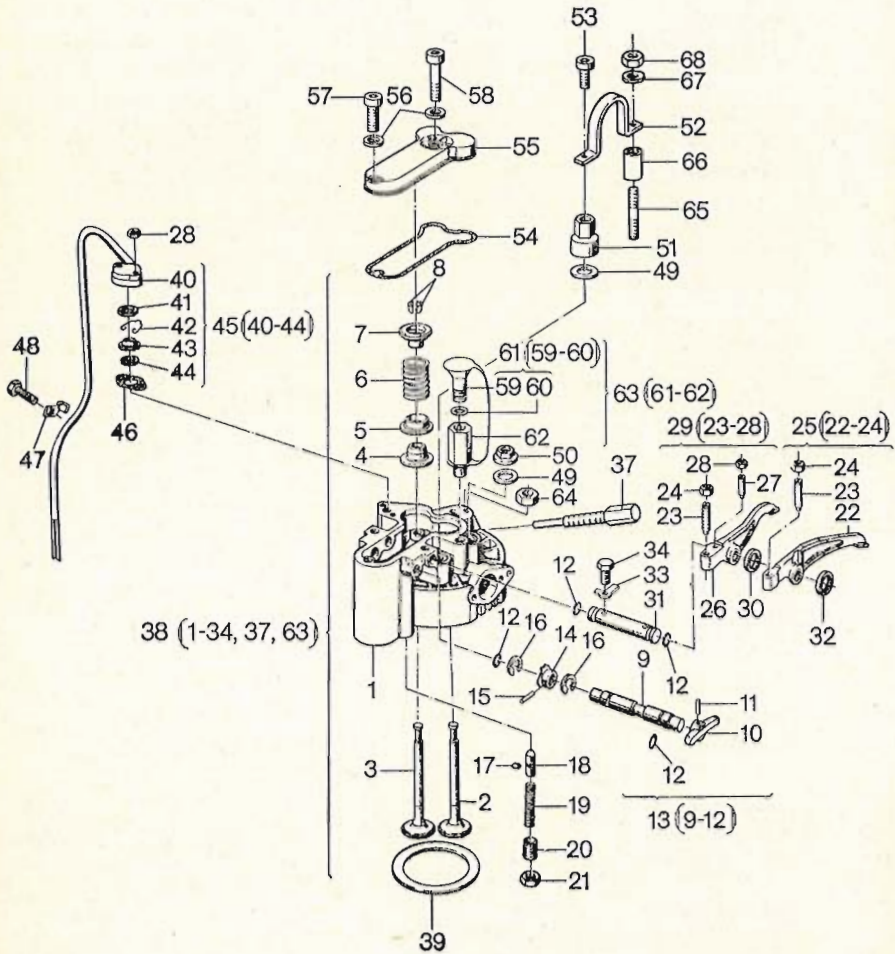

Fig. No.	Bestell-Nr.	Stück					Hints		
	Ordering No.	Quantity					Hinweise		
	No. référence	Quantites					Indications		
	No. de pedido	Cantidades					Indicaciones		
		E 71	E 75	E 79	E 780	E 786			
53	500 514 00	2	2	2	2	—	M 8 x 12	DIN 912 - 8.8	
54	031 741 00 W3	1	1	1	1	—			
54	032 042 00 W3	—	—	—	—	1			
55	031 742 00	1	1	1	1	—			
55	030 183 00	—	—	—	—	1			
56	501 629 00 W6	2	2	2	2	2	A 8 x 14	DIN 7603 - Cu	
57	500 522 00	1	1	1	1	1	M 8 x 30	DIN 912 - 8.8	
58	500 529 00	1	1	1	1	—	M 8 x 60	DIN 912 - 8.8	
58	500 530 00	—	—	—	—	1	M 8 x 70	DIN 912 - 8.8	
59	—	—	—	—	—	—			
60	501 541 00	2	2	2	2	2	12 x 2		
61	007 363 00 P1	1	1	1	1	1			
62	—	—	—	—	—	—			
63	009 507 00	1	1	1	1	1			
64	500 229 00	2	2	2	2	2	M 8	DIN 934 - 8	
65	501 300 00	—	—	—	—	2	M 8 x 35	DIN 938-8.8	
66	036 413 00	—	—	—	—	2			
67	500 167 00	—	—	—	—	2	8,4	DIN 125-St	
68	500 229 00	—	—	—	—	2	M 8	DIN 934-8	

M 09

Stoßstangen
Pushrod
Tige de culbuteur
Varilla de balancín

M 11

Steuerdeckel
Timing cover
Couvercle distribution
Tapa de mando

Tafel Nr.
Tabl. No.

09

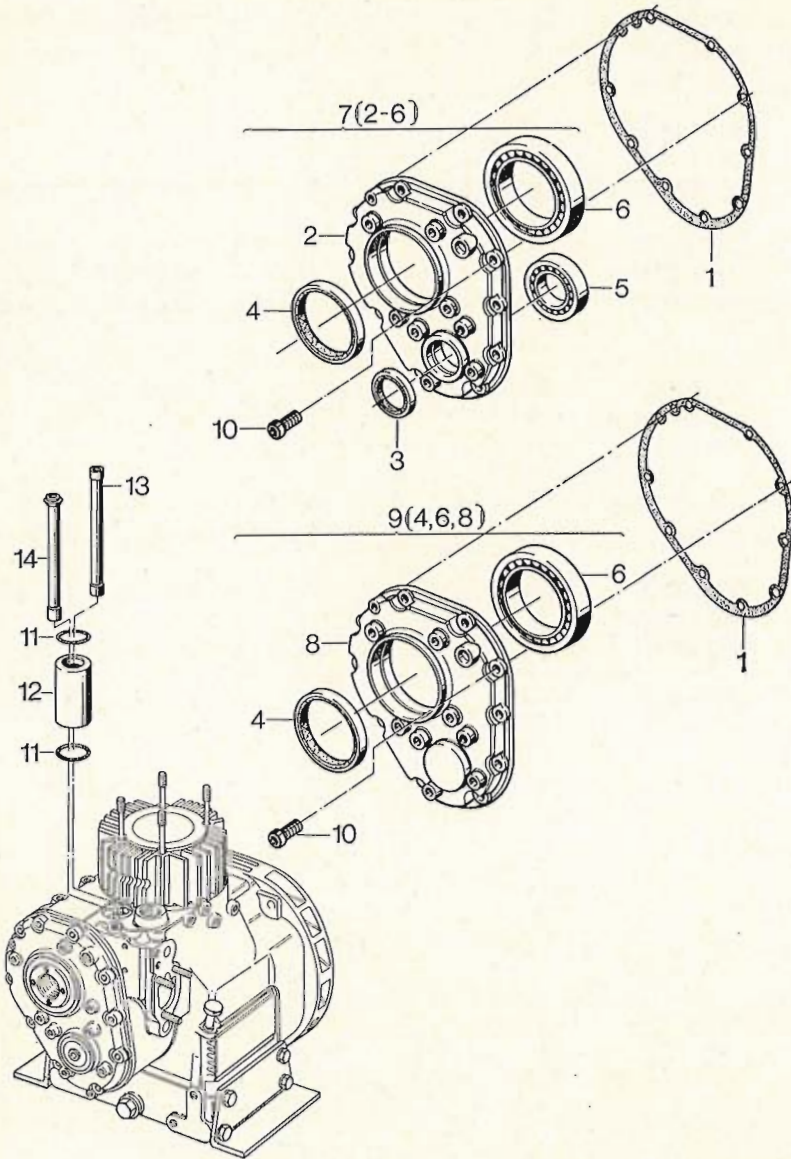

Fig. No.	Bestell-Nr. Ordering No. No. référence No. de pedido	Stück Quantity Quantities Cantidades					Hinweise Hints Indications Indicaciones	
		E 71	E 75	E 79	E 780	E 786		
1	031 745 00	1	1	1	1	1		
2	—	—	—	—	—	—		
3	400 338 00	1	1	1	1	1		
4	400 347 00	1	1	1	1	1		
5	500 130 00	1	1	1	1	1		
6	500 155 00	1	1	1	1	1		
7	003 411 01	1	1	1	1	1	E	
8	—	—	—	—	—	—		
9	003 413 01	1	1	1	1	1	ES	
10	500 521 00	10	10	10	10	10	M 8 x 25	DIN 912 - 8.8
11	400 232 00	2	2	2	2	2		
12	031 743 02	1	1	1	—	—		
12	032 003 01	—	—	—	1	—		
12	032 043 01	—	—	—	—	1		
13	003 409 01	1	1	1	—	—		
13	003 577 01	—	—	—	1	—		
13	003 601 01	—	—	—	—	1		
14	003 410 01	1	1	1	—	—		
14	003 578 01	—	—	—	1	—		
14	003 602 01	—	—	—	—	1		

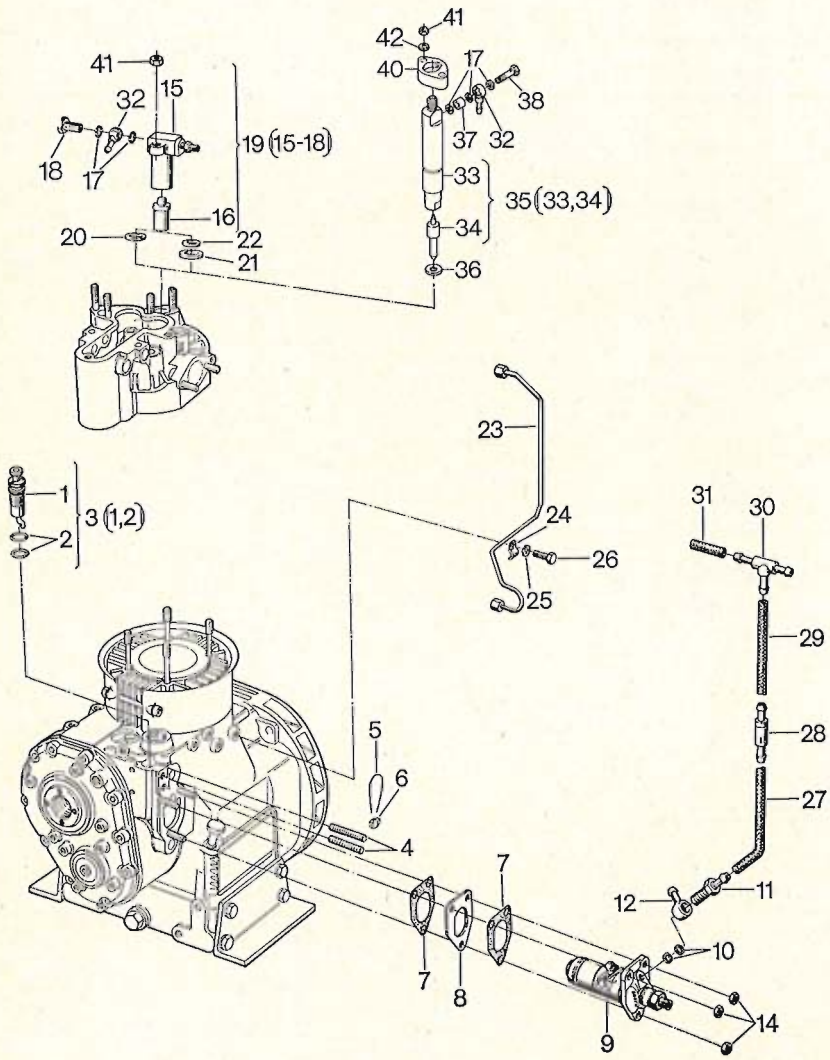

Fig. No.	Bestell-Nr.	Stück					Hinweise	
	Ordering No.	Quantity					Hints	
	No. référence	Quantites					Indications	
	No. de pedido	Cantidades					Indicaciones	
		E 71	E 75	E 79	E 780	E 786		
1	—	—	—	—	—	—		
2	400 229 00	2	2	2	2	2		
3	003 416 01	1	1	1	1	1		
4	031 746 00	2	2	2	2	2		
5	400 215 00	1	1	1	1	1		
6	400 214 00	1	1	1	1	1		
7	031 684 00	2	2	2	2	2		
8	031 683 02	0...1	0...1	0...1	0...1	0...1	0,15 mm	
8	031 685 01	0...1	0...1	0...1	0...1	0...1	0,20 mm	
8	031 686 01	0...1	0...1	0...1	0...1	0...1	0,25 mm	
8	031 687 01	0...1	0...1	0...1	0...1	0...1	0,30 mm	
9	400 052 01	1	1	1	—	—		
9	400 369 01	—	—	—	1	—		
9	502 571 10	—	—	—	—	1		
10	500 011 00	2	2	2	2	2	A 12 x 15,5	DIN 7603-Cu
11	036 623 00	1	1	1	1	1		
12	500 158 00	1	1	1	1	1		
14	500 229 00	3	3	3	3	3	M 8	DIN 934 - 8
15	—	—	—	—	—	—		
16	400 046 00 P1	1	1	1	1	—		
17	500 009 00	2	2	2	2	3	A 8 x 11,5	DIN 7603-Cu
18	500 061 00	1	1	1	1	—	A 2/3	DIN 7623
19	400 067 00	1	1	—	—	—		
19	400 068 00	—	—	1	1	—		
20	031 605 00	1	1	—	—	—		
21	030 129 00	—	—	1	1	—		
22	400 030 00 P1	—	—	1	1	—		
23	003 417 01	1	1	1	—	—		
23	003 579 00	—	—	—	1	—		
23	009 974 00	—	—	—	—	1		
24	031 747 00	1	1	1	1	1		
25	500 028 00	1	1	1	1	1		
26	500 267 00	1	1	1	1	1	M 8 x 16	DIN 933-8,8
27	036 637 00	1	1	1	1	1	4,5 x 2,5 —	50 mm
28	008 055 00 P1	1	1	1	1	1		
29	038 068 00	1	1	1	1	1	4,5 x 2,5 —	380 mm

Fig. No.	Bestell-Nr. Ordering No. No. référence No. de pedido	Stück Quantity Quantites Cantidades					Hinweise Hints Indications Indicaciones
		E 71	E 75	E 79	E 780	E 786	
30	501 578 00	1	1	1	1	1	
31	036 637 00	1	1	1	1	1	4,5 x 2,5 - 50 mm
32	500 157 00	1	1	1	1	1	
33	—	—	—	—	—	—	
34	502 576 10 P1	—	—	—	—	1	
35	502 572 10	—	—	—	—	1	
36	400 850 00	—	—	—	—	1	
37	032 929 00	—	—	—	—	1	
38	032 928 00	—	—	—	—	1	
39	—	—	—	—	—	—	
40	032 850 00	—	—	—	—	1	
41	500 229 00 P2	2	2	2	2	2	M 8 DIN 934-8
42	501 282 00 P2	—	—	—	—	2	8 DIN 127

M 17

Schwungräder
Flywheels
Volants
Volantes

M 26

Verschaltung
Cowling
Tole refroid.
Revestimiento

Tafel Nr.
Tabl. No.

11

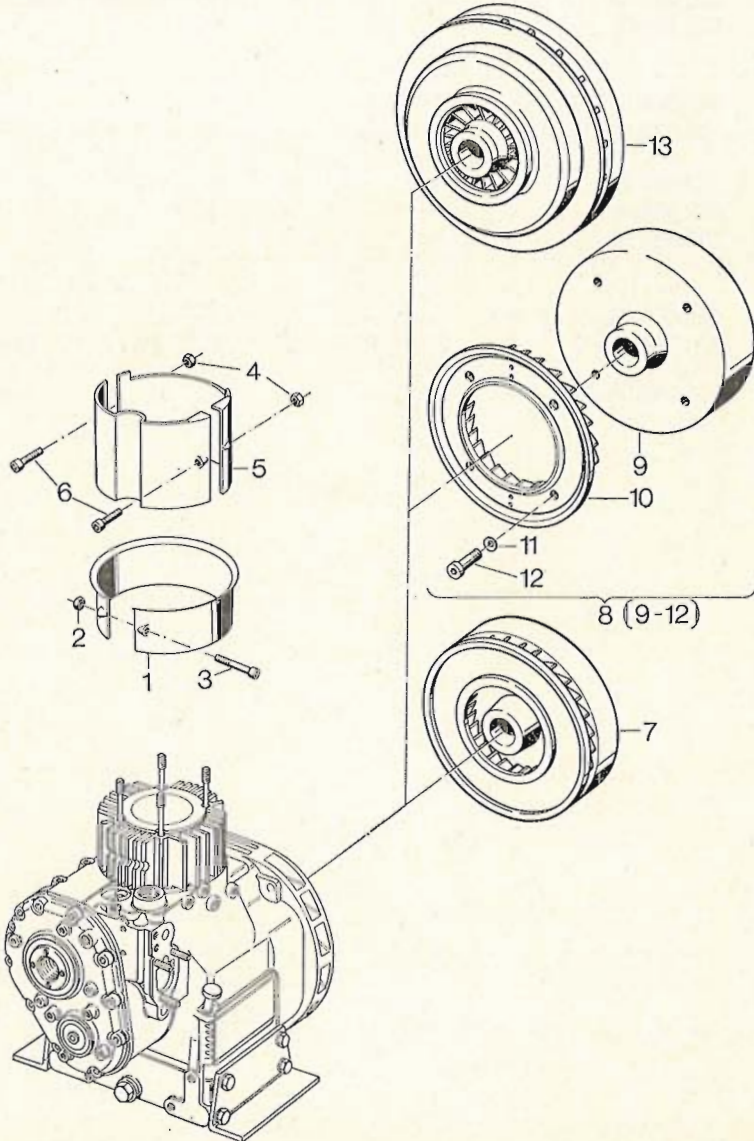

Fig. No.	Bestell-Nr. Ordering No. No. référence No. de pedido	Stück Quantity Quantites Cantidades					Hinweise Hints Indications Indicaciones	
		E 71	E 75	E 79	E 780	E 786		
1	030 068 00	1	1	—	—	—		
1	030 134 01	—	—	1	—	—		
1	030 158 01	—	—	—	1	—		
2	400 282 00	1	1	1	1	—		
3	500 498 00	1	1	1	1	—	AM 5 x 70	DIN 84-4.8
4	400 282 00	—	—	—	—	2	M 5	SSN 440-8 Cu
5	012 017 00	—	—	—	—	1		
6	500 496 00	—	—	—	—	2	AM 5 x 60	DIN 84-4.8
7	030 094 03	1	1	—	—	—		
8	009 085 00	—	—	1	—	—		
9	—	—	—	—	—	—		
10	031 130 00	1	1	1	—	—		
11	400 278 00	4	4	4	—	—		
12	400 357 00	4	4	4	—	—		
13	030 170 10	—	—	—	1	—		
13	037 691 01	—	—	—	—	1		

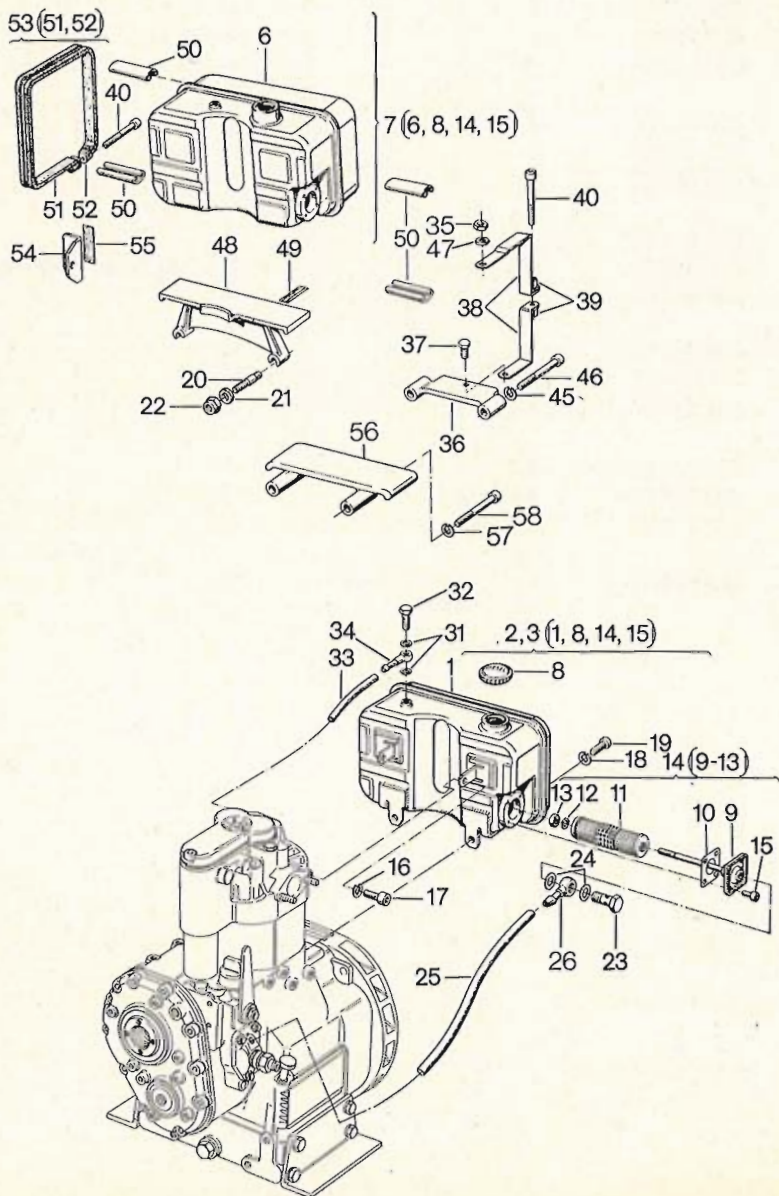

Fig. No.	Bestell-Nr.	Stück					Hinweise	
	Ordering No.	Quantity	Quantity	Quantity	Quantity	Quantity	Hints	Indications
	No. référence	Quantities	Quantities	Quantities	Quantities	Quantities	Indications	Indicaciones
	No. de pedido	Cantidades	Cantidades	Cantidades	Cantidades	Cantidades		
		E 71	E 75	E 79	E 780	E 786		
1	--	--	--	--	--	--		
2	004 126 00	1	1	1	--	--	5 Ltr.	
3	004 127 00	1	1	1	--	--	9 Ltr.	
4	--	--	--	--	--	--		
5	--	--	--	--	--	--		
6	--	--	--	--	--	--		
7	004 132 00	1	1	1	1	1	9 Ltr.	
8	400 327 00 P1	1	1	1	1	1		
9	--	--	--	--	--	--		
10	031 502 01 W2	1	1	1	1	1		
11	400 438 00 W2	1	1	1	1	1		
12	031 506 00 W1	1	1	1	1	1		
13	400 835 00 W1	1	1	1	1	1	M 8	SSN003-04Zn
14	003 291 02	1	1	1	1	1		
15	500 627 00 W4	4	4	4	4	4	M 6 x 10	DIN 912 - 8.8
16	502 085 00	2	2	2	2	--	8	DIN 128-A3C
16	501 356 00	--	--	--	--	2	10	DIN 128-A3C
17	501 654 00	2	2	2	--	--	M 8 x 16	DIN 912-8.8A3C
17	500 519 00	2	2	2	2	--	M 8 x 20	DIN 912 - 8.8
17	500 538 00	--	--	--	--	2	M 10 x 25	DIN 912 - 8.8
18	500 029 00	2	2	2	--	--	10	DIN 128
19	501 732 00	2	2	2	--	--	M 10 x 20	DIN 912-8.8A3C
20	501 803 00	--	--	--	2	2	M 10x35	DIN 938-8.8 A3C
21	500 169 00	2	2	2	2	2	B 10,5	DIN 125 - St
22	501 802 00	--	--	--	2	2	BM 10	SSN 001-8 Zn
23	500 064 00	1	1	1	1	1	A 8	DIN 7623
24	500 012 00 W4	2	2	2	2	2	A 14 x 18	DIN 7603-Cu
25	036 934 00	1	1	1	1	1	7,00 x 2,5 - 360 mm	
26	500 159 00	1	1	1	1	1		
31	500 009 00	2	2	2	2	2	A 8 x 11,5	DIN 7603-Cu
32	500 061 00	1	1	1	1	1	A 2/3	DIN 7623
33	036 637 00	1	1	1	1	1	4,5 x 2,5 - 50 mm	
34	500 157 00	1	1	1	1	1		

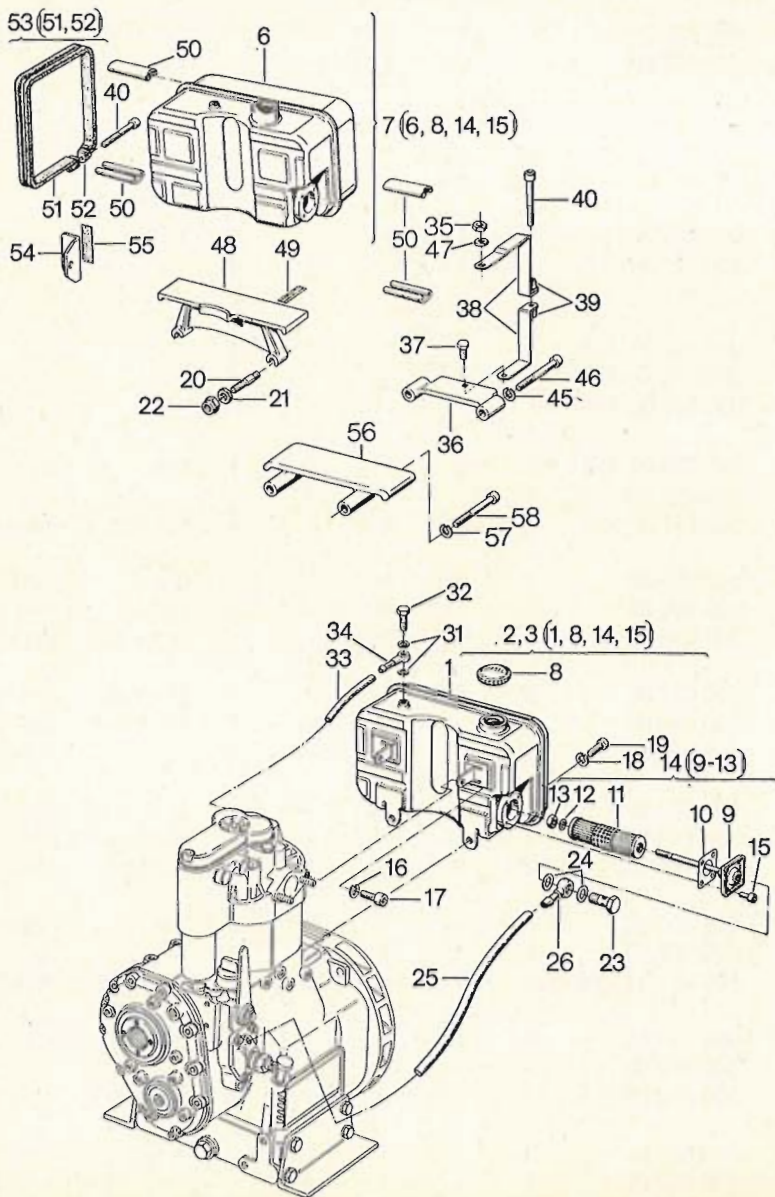

Fig. No.	Bestell-Nr. Ordering No. No. référence No. de pedido	Stück Quantity Quantites Cantidades					Hinweise Hints Indications Indicaciones	
		E 71	E 75	E 79	E 780	E 786		
35	501 480 00	1	1	1	—	—	M 8	DIN 934-8 A3C
36	030 063 10	1	1	1	—	—		
37	501 655 00	1	1	1	—	—	M 6 x 12	DIN 933-8.8 A3C
38	007 783 00	1	1	1	—	—	5 Ltr.	
39	007 782 01	1	1	1	—	—	9 Ltr.	
40	035 377 00	2	2	2	2	2		
43	—	—	—	—	—	—		
44	—	—	—	—	—	—		
45	500 029 00	2	2	2	—	—	10	DIN 128
46	500 552 00	2	2	2	—	—	M 10 x 60	DIN 912 - 8.8
47	501 481 00	1	1	1	—	—	8,4	DIN 125-St A3C
48	030 157 01	—	—	—	1	—		
48	030 190 01	—	—	—	—	1		
49	035 063 00	2	2	2	2	—		
49	035 064 00	—	—	—	—	2		
50	031 886 00	4	4	4	2	4		
51	005 627 00	2	2	2	—	—		
51	032 005 00	—	—	—	2	2		
52	007 785 00	—	—	—	2	2		
53	005 627 00	—	—	—	2	2		
54	030 148 00	2	2	2	2	—		
54	030 182 00	—	—	—	—	2		
55	035 062 00	2	2	2	2	2		
56	038 533 00	1	1	1	—	—		
57	500 169 00	2	2	2	—	—	10,5	DIN 125-St
58	500 840 00	2	2	2	—	—	M 10 x 90	DIN 912-8.8

A 01

Kraftstoffilter
Fuel filter
Filtre à carburant
Filtro de combustible

Tafel Nr.
Tabl. No.

13

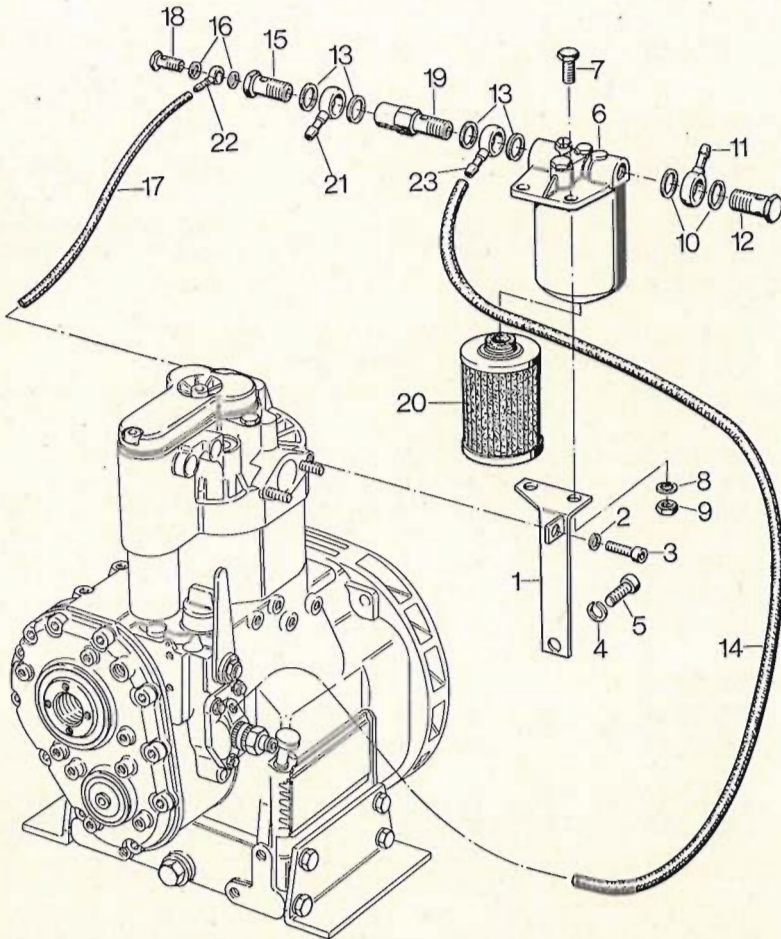

Fig. No.	Bestell-Nr. Ordering No. No. référence No. de pedido	Stück Quantity Quantites Cantidades					Hinweise Hints Indications Indicaciones	
		E 71	E 75	E 79	E 780	E 786		
1	006 211 00	1	1	1	—	—		
1	004 202 00	—	—	—	1	—		
1	004 203 00	—	—	—	—	1		
2	500 028 00	1	1	1	1	—	8	DIN 128
2	500 029 00	—	—	—	—	1	10	DIN 128
3	500 519 00	1	1	1	1	1	M 8 x 20	DIN 912-8.8
3	500 538 00	—	—	—	—	1	M 10 x 25	DIN 912-8.8
4	500 029 00	1	1	1	1	1	10	DIN 128
5	500 536 00	—	—	—	—	1	M 10 x 20	DIN 912-8.8
5	500 292 00	1	1	1	1	1	M 10 x 25	DIN 933-8.8
6	400 674 00	1	1	1	1	1		
7	500 293 00	2	2	2	2	2	M 10 x 30	DIN 933-8.8
8	500 029 00	2	2	2	2	2	10	DIN 128
9	500 235 00	2	2	2	2	2	M 10	DIN 934-8
10	500 012 00	2	2	2	2	2	A 14 x 18	DIN 7603-Cu
11	500 159 00	1	1	1	1	1		
12	500 064 00	1	1	1	1	1	A 8	DIN 7623
13	500 012 00	4	4	4	4	4	A 14 x 18	DIN 7603-Cu
14	036 732 00	1	1	1	—	—	7,0 x 2,5 — 470 mm	
14	036 742 00	—	—	—	1	1	7,0 x 2,5 — 550 mm	
15	032 807 00	1	1	1	1	1		
16	500 009 00	2	2	2	2	2	A 8 x 11,5	DIN 7603-Cu
17	036 637 00	1	1	1	—	—	4,5 x 2,5 — 50 mm	
17	036 731 00	—	—	—	1	1	4,5 x 2,5 — 65 mm	
18	500 061 00	1	1	1	1	1	A 2/3	DIN 7623
19	034 977 00	1	1	1	1	1		
20	400 073 00	1	1	1	1	1		
21	501 517 00	1	1	1	1	1		
22	500 157 00	1	1	1	1	1		
23	500 159 00	1	1	1	1	1		

A 02

Luftfilter
Air filter
Filtre à air
Filtro de aire

Tafel Nr.
Tabl. No.

14

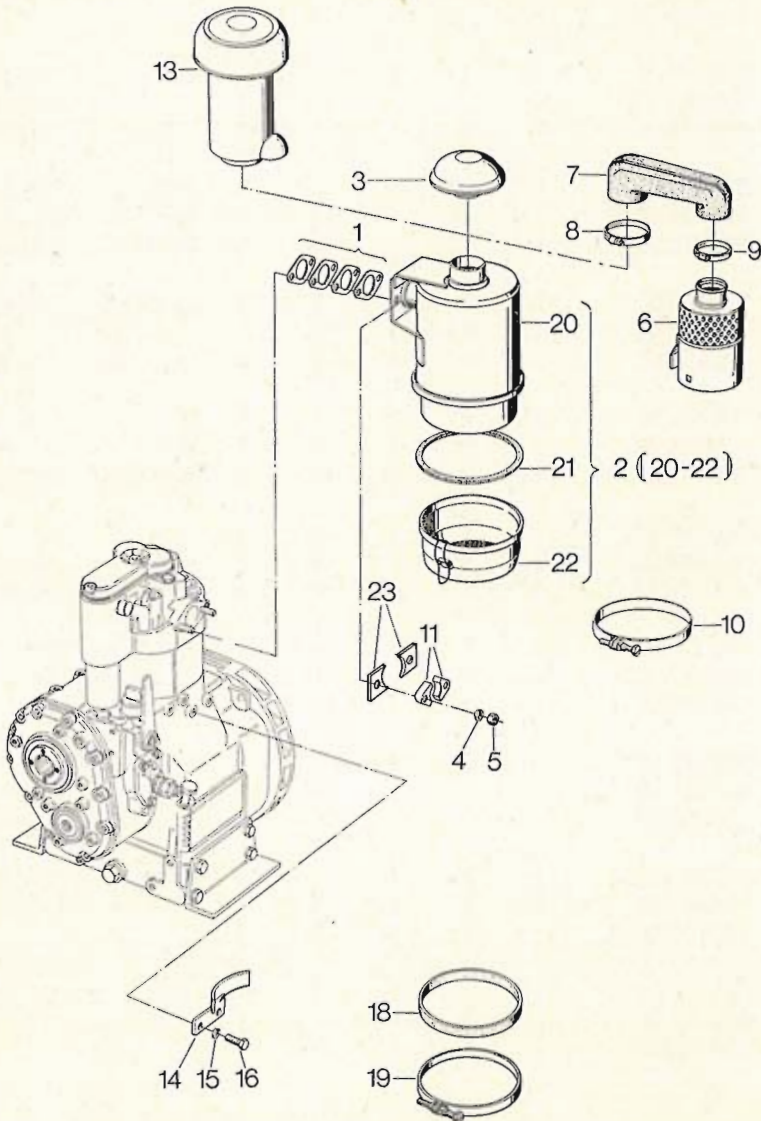

Fig. No.	Bestell-Nr. Ordering No. No. référence No. de pedido	Stück Quantity Quantites Cantidades					Hinweise Hints Indications Indicaciones	
		E 71	E 75	E 79	E 780	E 786		
1	011 540 00W1	1	1	1	1	—		
1	011 587 00 W1	—	—	—	—	1		
2	401 029 00	1	1	—	—	—		
2	400 892 00	—	—	1	—	—		
2	401 030 00	—	—	—	1	—		
2	010 785 00	—	—	—	—	1		
3	400 995 00 P1	1	1	—	—	—		
3	400 893 00 P1	—	—	1	—	—		
3	400 404 00 P1	—	—	—	1	—		
3	400 367 00 P1	—	—	—	—	1	62 mm	
4	502 085 00	2	2	—	—	—	8 Zn	DIN 128
4	502 852 00	—	—	2	2	—	VSK 8	A3C
4	501 356 00	—	—	—	—	2	10 Zn	DIN 128
5	400 816 00	2	2	—	—	—	M 8	Ms
5	400 284 00	—	—	2	2	—	SSN 440-8 Cu	
5	501 458 00	—	—	—	—	2	M 10 Zn	DIN 934-8 A3C
6	400 996 00	1	1	—	—	—		
6	401 031 00	—	—	—	1	—		
7	033 245 00	1	1	—	—	—		
7	035 319 00	—	—	—	1	—		
8	400 535 00	1	1	—	—	—		
8	400 955 00	—	—	—	1	—		
9	400 715 00	1	1	—	1	—		
10	401 010 00	1	1	—	—	—		
10	400 296 00	—	—	—	1	—		
11	039 037 00	—	—	2	2	—		
12	—	—	—	—	—	—		
13	400 351 00	—	—	1	—	—		
13	011 194 00	—	—	—	—	1		
14	030 133 00	—	—	1	—	—		
15	500 028 00	—	—	1	—	—	8	DIN 128
16	500 267 00	—	—	1	—	—	M 8 x 16	DIN 933-8.8
17	—	—	—	—	—	—		
18	031 767 01	—	—	1	—	—		
19	400 293 00	—	—	1	—	—		
20	—	—	—	—	—	—		

Fig. No.	Bestell-Nr. Ordering No. No. référence No. de pedido	Stück Quantity Quantites Cantidades					Hinweise Hints Indications Indicaciones
		E 71	E 75	E 79	E 780	E 786	
21	490 375 00 P1	1	1	—	—	—	
21	490 196 00 P1	—	—	1	—	—	
21	490 380 00 P1	—	—	—	1	1	
22	490 381 00	1	1	—	—	—	
22	490 186 00	—	—	1	—	—	
22	490 379 00	—	—	—	1	—	
22	490 566 00	—	—	—	—	1	
23	039 454 00	—	—	—	—	2	

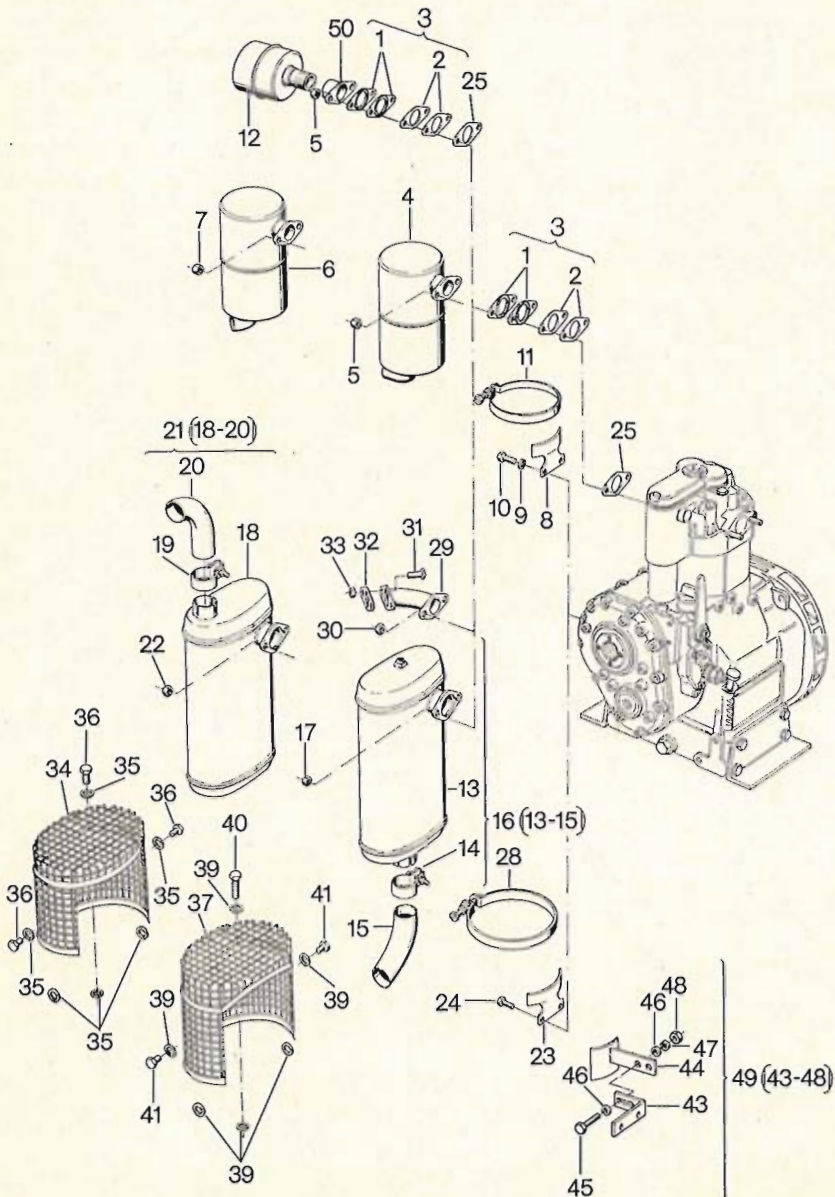

Fig. No.	Bestell-Nr.	Stück					Hinweise	
	Ordering No.	Quantity					Hints	
	No. référence	Quantites					Indications	
	No. de pedido	Cantidades					Indicaciones	
		E 71	E 75	E 79	E 780	E 786		
1	—	—	—	—	—	—		
2	—	—	—	—	—	—	32 x 53	DIN 71511
3	011 539 00	1	1	1	1	—		
4	008 599 00	1	1	1	—	—		
5	500 230 00	2	2	2	2	—	M 8	Ms DIN 934
5	500 237 00	—	—	—	—	2	M 10	DIN 934-Ms
6	008 600 00	1	1	1	—	—		
7	400 816 00	2	2	2	—	—	M 8	Ms
8	030 783 00	1	1	1	—	—		
9	500 028 00	2	2	2	—	—	8	DIN 128
10	500 267 00	2	2	2	—	—	M 8 x 16	DIN 933 - 8.8
11	400 290 00	1	1	1	—	—		
12	008 722 00	1	1	1	1	1		
13	—	—	—	—	—	—		
14	037 271 00	1	1	1	1	1		
15	037 272 00	1	1	1	1	—		
15	037 407 00	—	—	—	—	1		
16	008 593 00	1	1	1	1	—		
16	008 579 00	—	—	—	—	1		
17	400 816 00	2	2	2	2	—		
17	500 237 00	—	—	—	—	2	M 10 Ms	DIN 934 Ms
18	—	—	—	—	—	—		
19	037 271 00	1	1	1	1	1		
20	037 272 00	1	1	1	1	—		
20	037 407 00	—	—	—	—	1		
21	008 622 00	1	1	1	1	—		
21	008 578 00	—	—	—	—	1		
22	400 816 00	2	2	2	2	—		
22	500 237 00	—	—	—	—	2	M 10 Ms	DIN 934 Ms
23	030 051 01	1	1	1	—	—		
23	030 156 00	—	—	—	1	—		
23	030 668 00	—	—	—	—	1		
24	500 267 00	2	2	2	2	2	M 8 x 16	DIN 933 - 8.8

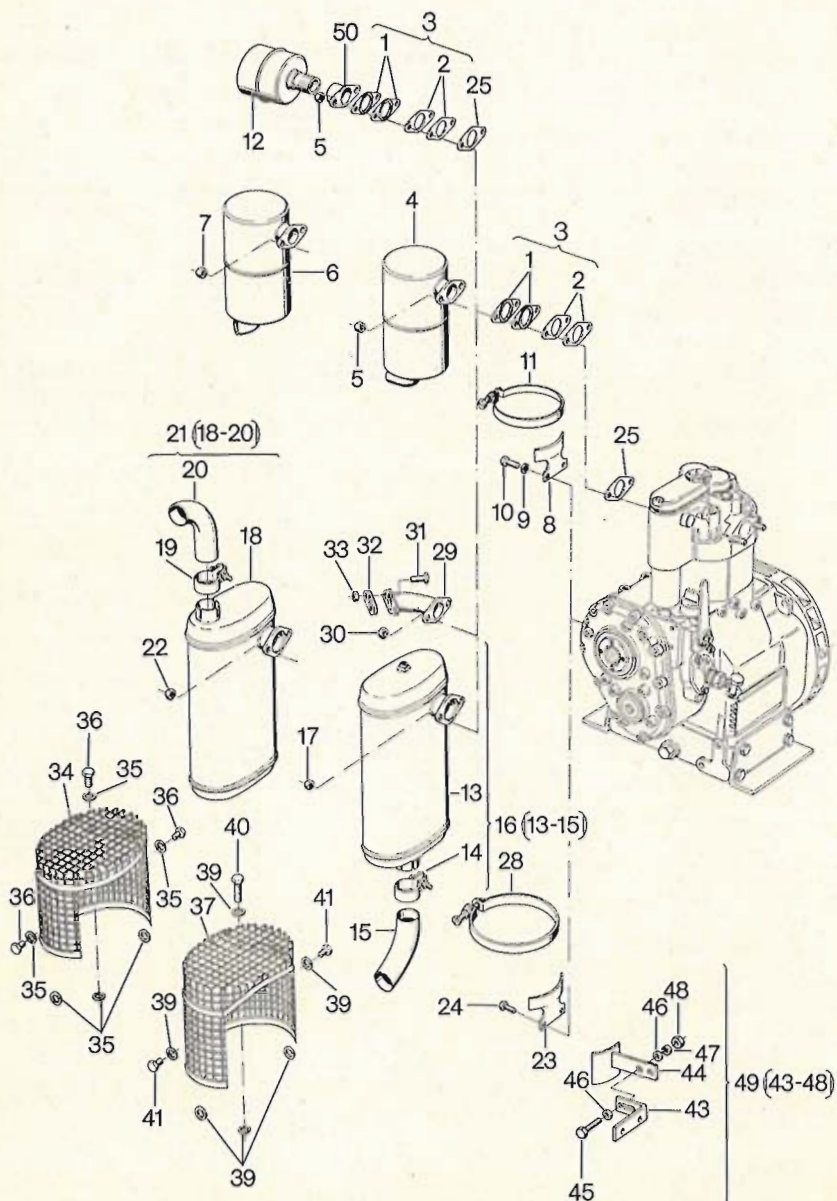

Fig. No.	Bestell-Nr. Ordering No. No. référence No. de pedido	Stück Quantity Quantities Cantidades					Hinweise Hints Indications Indicaciones	
		E 71	E 75	E 79	E 780	E 786		
25	500 023 00	—	—	—	—	1		
28	400 294 00	1	1	1	1	—		
28	400 296 00	—	—	—	—	1		
29	003 125 00	1	1	1	1	—		
30	400 816 00	2	2	2	2	—		
31	501 354 00	2	2	2	2	—	M 8 x 20	DIN 933-8.8 A3C
32	502 868 00	4	4	4	4	—	32 x 53	DIN 71511
33	400 816 00	2	2	2	2	—		
34	007 853 00	1	1	1	1	—		
35	500 168 00	6	6	6	6	—	8,4	DIN 125 Ms
36	501 731 00	3	3	3	3	—	M 8 x 10	DIN912-8.8Zn
37	007 854 00	—	—	—	—	1		
39	500 168 00	—	—	—	—	6	8,4	DIN 125 Ms
40	501 731 00	—	—	—	—	1	M 8 x 10	DIN912-8.8Zn
41	501 731 00	—	—	—	—	2	M 8 x 10	DIN912-8.8Zn
42	—	—	—	—	—	—		
43	—	—	—	—	—	—		
44	—	—	—	—	—	—		
45	500 268 00	2	2	2	—	—	M 8 x 20	DIN 933 - 8.8
46	500 167 00	4	4	4	—	—	8,4	DIN 125 - St
47	500 028 00	2	2	2	—	—	8	DIN 128
48	500 229 00	2	2	2	—	—	8	DIN 934 - 8
49	003 144 10	1	1	1	—	—		
50	038 289 00	1	1	1	1	—		
50	038 291 00	—	—	—	—	1		

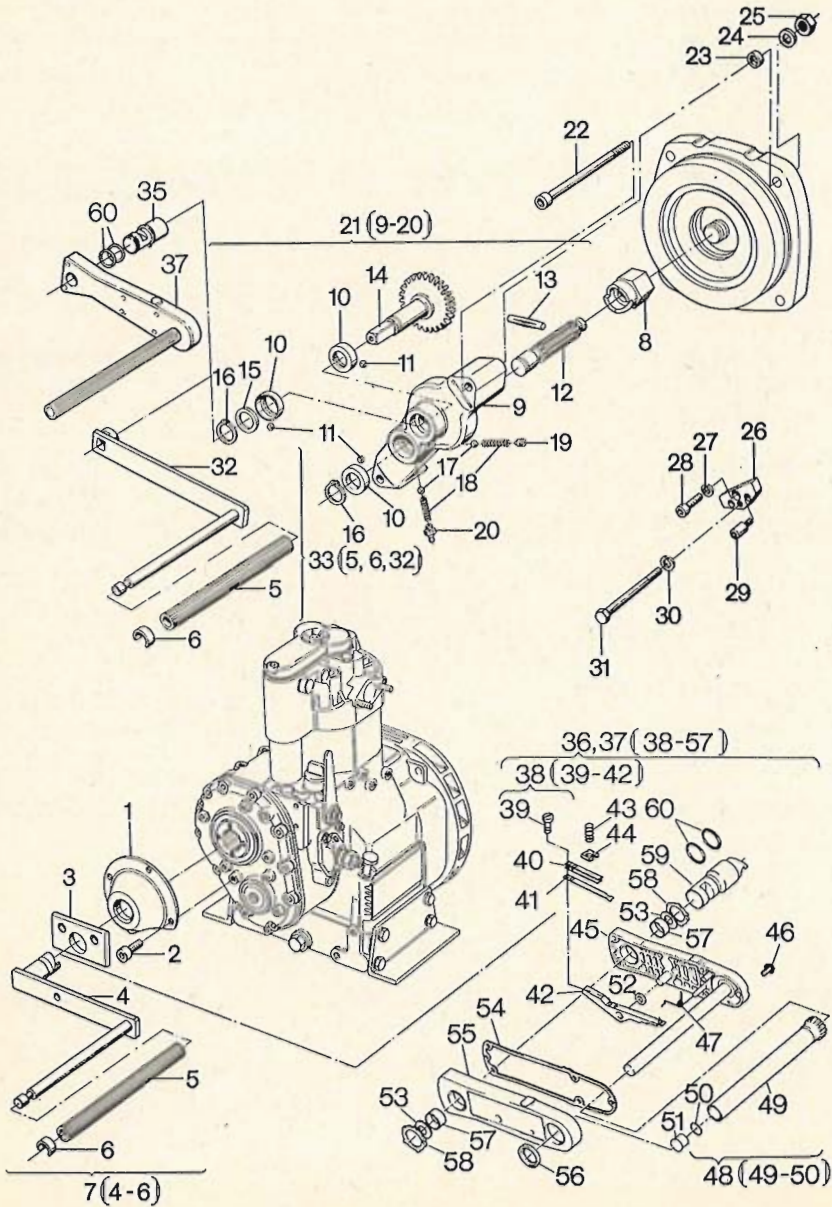

Fig. No.	Bestell-Nr. Ordering No. No. référence No. de pedido	Stück Quantity Quantites Cantidades					Hinweise Hints Indicaciones Indicaciones	
		E 71	E 75	E 79	E 780	E 786		
1	033 827 00	1	1	1	1	1		
2	501 654 00	4	4	4	4	4	M 8 x 16	DIN 912-A3C
3	030 107 00	1	1	1	1	1		
4	—	—	—	—	—	—		
5	035 224 00	1	1	1	1	1		
6	035 154 00	1	1	1	1	1		
7	003 019 02	1	1	1	1	1	50 mm	
7	003 033 02	1	1	1	1	1	77 mm	
7	003 032 02	1	1	1	1	1	122 mm	
7	003 015 00	1	1	1	1	1	177 mm	
7	003 031 02	1	1	1	1	1	242 mm	
7	008 637 00	1	1	1	1	1	320 mm	
8	030 074 01	1	1	1	—	—		
8	037 324 00	—	—	—	1	—		
8	030 669 00	—	—	—	—	1		
9	—	—	—	—	—	—		
10	031 763 01	3	3	3	3	3		
11	500 098 00	45	45	45	45	45		
12	030 085 00	1	1	1	1	1		
13	500 095 00	1	1	1	1	1	8 x 45	DIN 1475
14	030 113 00	1	1	1	1	1		
15	030 124 01	1	1	1	1	1		
16	500 204 00	2	2	2	2	2	24 x 1,2	DIN 471
17	500 098 00	2	2	2	2	2		
18	031 591 00	2	2	2	2	2		
19	030 794 00	1	1	1	1	1		
20	500 078 00	1	1	1	1	1	AM 8 x 1	DIN 71412
21	003 419 03	1	1	—	—	—		
21	003 356 02	—	—	1	1	1		
22	500 559 00	2	2	—	—	—	M 10 x 120	DIN 912 - 8.8
23	031 754 00	2	2	2	—	—		
24	500 169 00	2	2	4	—	—	B 10,5	DIN 125 - St
25	500 235 00	2	2	2	—	—	M 10	DIN 934 - 8

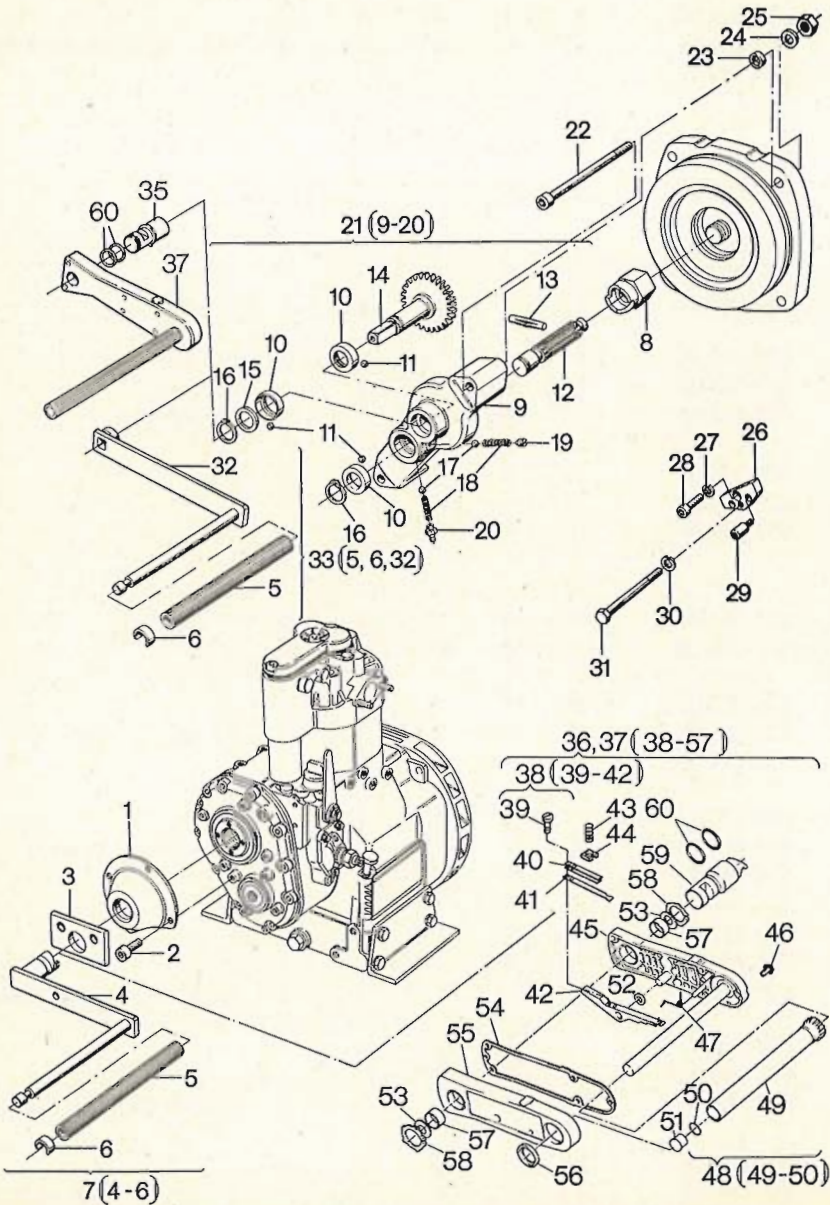

Fig. No.	Bestell-Nr. Ordering No. No. référence No. de pedido	Stück Quantity Quantites Cantidades					Hinweise Hints Indications Indicaciones	
		E 71	E 75	E 79	E 780	E 786		
26	030 123 01	—	—	2	—	—		
26	037 323 00	—	—	—	2	—		
27	—	—	—	—	—	—		
28	500 416 00	—	—	2	—	—	M 10 x 55	DIN 938 - 5.6
28	500 526 00	—	—	—	4	—	M 8 x 45	DIN 912 - 8.8
29	500 832 00	—	—	4	4	—	8 m 6 x 30	DIN 7-St50k
30	500 029 00	—	—	4	2	2	10	DIN 128
31	500 304 00	—	—	2	2	2	M 10 x 90	DIN 931 - 8.8
32	—	—	—	—	—	—		
33	003 030 02	1	1	1	1	1		
35	010 189 00	1	1	1	1	1		
36	010 278 04	1	1	1	1	1	„A“	
37	010 279 04	1	1	1	1	1	„B“	
38	010 114 03	1	1	1	1	1		
39	503 165 00	2	2	2	2	2	M 5x8	DIN 6912-8.8
40	039 171 00	2	2	2	2	2		
41	038 121 02	1	1	1	1	1		
42	—	—	—	—	—	—		
43	038 184 00	1	1	1	1	1		
44	038 820 00	1	1	1	1	1		
45	—	—	—	—	—	—		
46	501 944 00	5	5	5	5	5	M 6 x 25	DIN 6912-8.8 A3C
47	038 784 00	1	1	1	1	1	„A“	
47	038 785 00	1	1	1	1	1	„B“	
48	010 113 10	1	1	1	1	1		
49	—	—	—	—	—	—		
50	501 691 00	1	1	1	1	1	19 x 1,8	DIN 769
51	501 992 00	1	1	1	1	1		
52	501 958 00	1	1	1	1	1	10 x 16 x 1,0	DIN 988
53	039 286 00	0...2	0...2	0...2	0...2	0...2	30 x 38 x 0,15	
54	038 130 00	1	1	1	1	1		
55	—	—	—	—	—	—		
56	501 942 00	1	1	1	1	1		
57	501 934 00	2	2	2	2	2		
58	501 943 00	2	2	2	2	2	A 30 x 1,5 K	DIN 983
59	010 196 00	1	1	1	1	1	77 mm	
59	010 197 00	1	1	1	1	1	122 mm	
59	010 200 00	1	1	1	1	1	242 mm	
59	010 487 00	1	1	1	1	1	320 mm	
60	502 585 00	2	2	2	2	2		

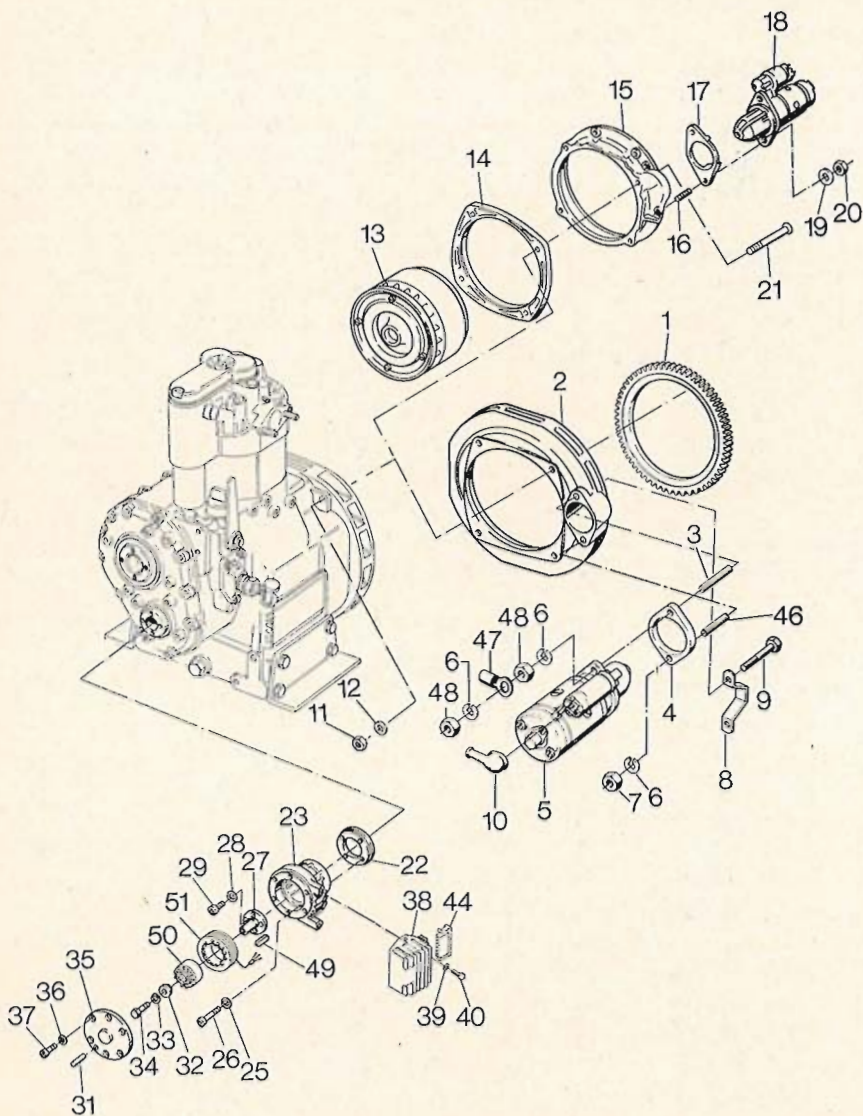

Fig. No.	Bestell-Nr. Ordering No. No. référence No. de pedido	Stück Quantity Quantities Cantidades					Hinweise Hints Indications Indicaciones	
		E 71	E 75	E 79	E 780	E 786		
1	032 044 10	—	—	—	1	1		
1	038 095 01	1	1	1	—	—		
2	003 115 00	—	—	—	—	1		
3	502 897 00	—	—	—	1	1	M 12 x 45	DIN 835-8.8 A3C
4	030 200 00	—	—	—	1	1		
5	400 005 00	—	—	—	1	1	12 V	
6	500 632 00	—	—	—	3	3	12	DIN 128 A3C
7	500 936 00	—	—	—	1	1	M 12	DIN 934-8 A3C
8	036 842 00	—	—	—	1	—		
9	500 318 00	—	—	—	2	—	M 12 x 70	DIN 931-8.8
10	400 266 00	—	—	—	1	1		
11	400 286 00	4	4	4	—	—	M 10	SSN 440-8Cu
12	501 459 00	4	4	4	—	—	10,5	DIN 125-St A3C
13	038 092 01	—	—	1	—	—		
14	030 141 00	—	—	1	—	—		
15	038 039 00	1	1	1	—	—		
16	501 453 00	2	2	2	—	—	M 10 x 65	DIN 835-8.8 A3C
17	038 090 00	1	1	1	—	—		
18	501 930 00	1	1	1	—	—	12 V	
19	500 617 00	2	2	2	—	—	A 10	DIN 137
20	500 235 00	2	2	2	—	—	M 10	DIN 934-8
21	400 270 00	4	4	—	—	—	M 10 x 65	
21	502 687 00	—	—	4	—	—	M 10 x 90	DIN 7991-8.8
22	038 484 01	—	—	—	1	1	„U“	
23	038 475 01	1	1	1	1	1		
24	—	—	—	—	—	—		
25	500 028 00	4	4	4	4	4	8	DIN 128
26	500 521 00	4	4	4	4	4	M 8 x 25	DIN 912-8.8
26	500 523 00	4	4	4	4	4	M 8 x 35	DIN 912-8.8 „U“
27	038 562 10	1	1	1	1	1		
28	500 617 00	4	4	4	4	4	A 10	DIN 137
29	500 535 00	4	4	4	4	4	M 10x16	DIN 6912-8.8
30	—	—	—	—	—	—		

A 05

Starter, Generator
Starter, alternateur
Demarreur, alternateur
Arrancador, alternador

Tafel Nr.
Tabl. No.

17

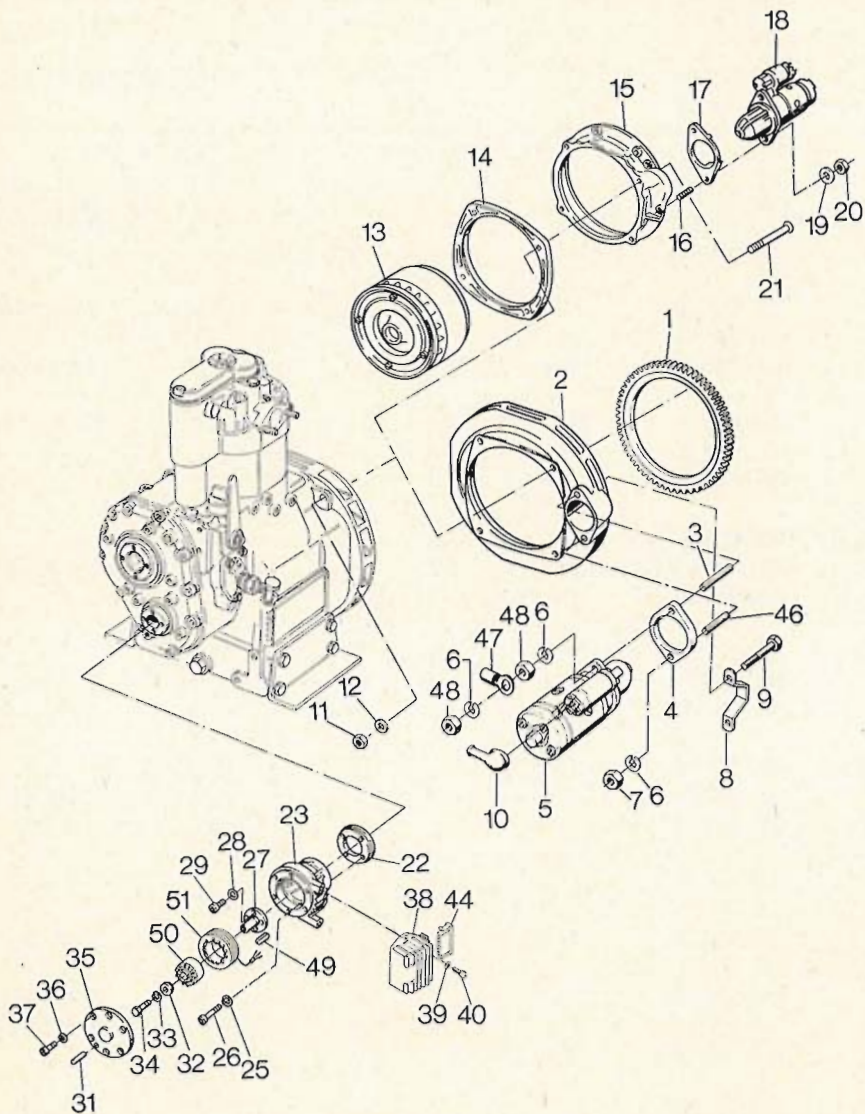

Fig. No.	Bestell-Nr. Ordering No. No. référence No. de pedido	Stück Quantity Quantites Cantidades					Hinweise Hints Indications Indicaciones		
		E 71	E 75	E 79	E 780	E 786			
31	500 124 00	1	1	1	1	1	5 x 24	DIN 1472	
32	500 706 00	1	1	1	1	1	10,5	DIN 7349 A3C	
33	502 451 00	1	1	1	1	1	B 10 x 18	DIN 137	
34	500 540 00	1	1	1	1	1	M 10 x 25	DIN 6912-8.8	
35	038 476 01	1	1	1	1	1			
36	500 026 00	6	6	6	6	6	5	DIN 128	
37	502 696 00	6	6	6	6	6	M 5 x 25	DIN 912-8.8	
38	502 694 00	1	1	1	1	1			
39	500 951 00	2	2	2	2	2	A 8	DIN 137	
40	502 432 00	2	2	2	2	2	M 8 x 25	DIN 933-8.8 A3C	
41	038 011 00	1	1	1	1	1			
42	500 027 00	1	1	1	1	1	6	DIN 128	
43	500 503 00	1	1	1	1	1	M 6 x 8	DIN 912-8.8	
44	502 802 00	1	1	1	1	1			
45	501 674 00	1	1	1	1	1			
46	500 424 00	—	—	—	1	1	M 12 x 35	DIN 835-5.6 A3C	
47	500 634 00	—	—	—	1	1			
48	500 635 00	—	—	—	2	2	M 12	DIN 936-17 H A3E	
49	500 108 00	1	1	1	1	1	4 x 4 x 25	DIN 6885	
50	039 439 00	1	1	1	1	1			
51	503 455 03	1	1	1	1	1			

38 (5-7,17-18,23-28,30-36,40-46)
 39 (5-6,17-18,23-28,30-36,40-46)

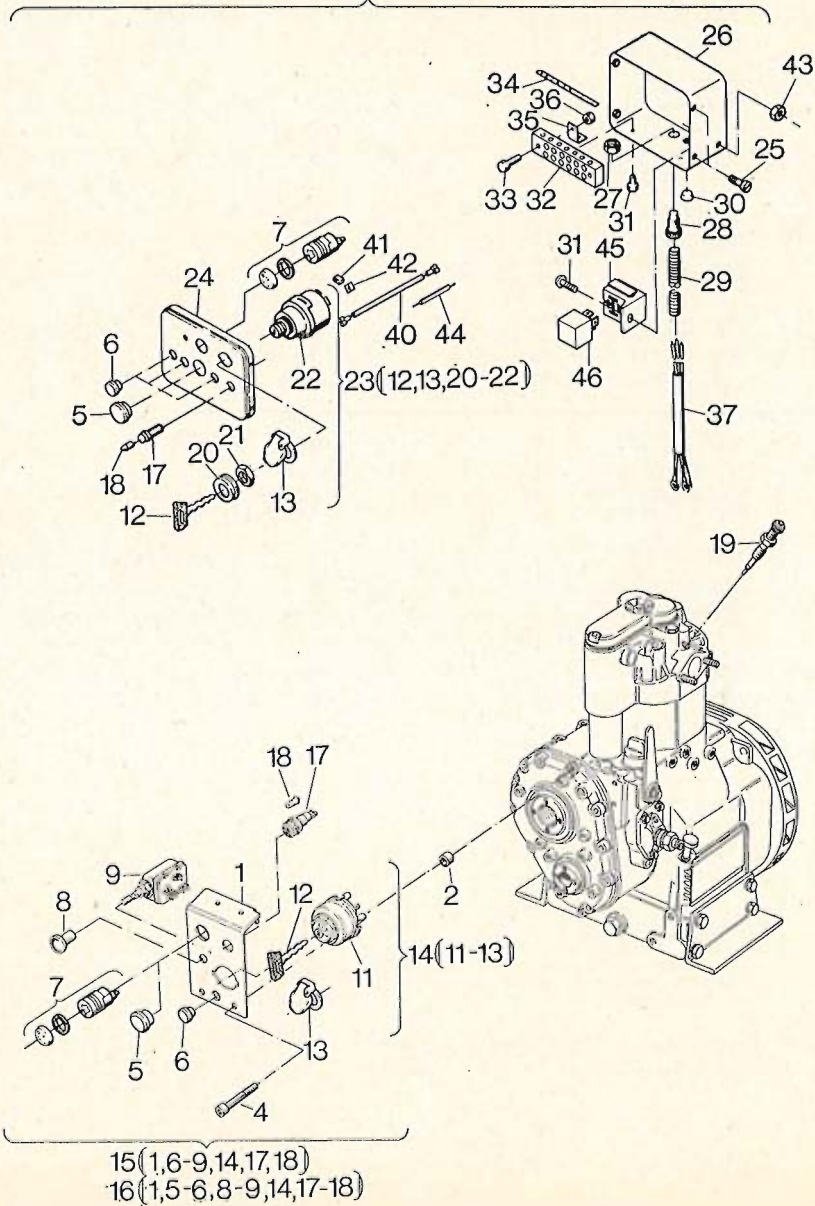

Fig. No.	Bestell-Nr. Ordering No. No. référence No. de pedido	Stück Quantity Quantites Cantidades					Hinweise Hints Indications Indicaciones	
		E 71	E 75	E 79	E 780	E 786		
1	035 086 00	1	1	1	1	1		
2	032 004 00	2	2	2	2	2		
3	—	—	—	—	—	—		
4	502 488 00	2	2	2	2	2	M 8x60	DIN 912-8.8 A3C
4	501 209 00	—	—	—	2	2	„U“ M8x85	DIN 912-8.8 A3C
5	400 914 00	1	1	1	1	1	24	
6	400 960 00	3	3	3	3	3	17	
7	400 109 00	1	1	1	1	—		
8	400 154 00	1	1	1	1	1		
9	400 095 00	1	1	1	1	1		
10	—	—	—	—	—	—		
11	—	—	—	—	—	—		
12	503 453 00	1	1	1	1	1		
13	490 509 00	1	1	1	1	1		
14	501 661 00	1	1	1	1	1		
15	007 100 01	1	1	1	1	—		
16	010 593 00	—	—	—	—	1		
17	501 765 00	1	1	1	1	1	BATT	
18	400 097 00	1	1	1	1	1	12 V	2 W
19	400 312 00	1	1	1	1	—		
20	—	—	—	—	—	—		
21	—	—	—	—	—	—		
22	—	—	—	—	—	—		
23	502 765 01	1	1	1	1	1		
24	035 092 11	1	1	1	1	1		
25	502 892 00	4	4	4	4	4	M 6 x 12	DIN 7985-8.8 Zn
26	007 163 11	1	1	1	1	1		
27	501 591 00	1	1	1	1	1		
28	501 590 10	1	1	1	1	1		
29	—	—	—	—	—	—		
30	501 608 00	2	2	2	2	2		
31	500 493 00	3	3	3	3	3	M5x10	DIN 7985-4.8 A3R
32	501 607 00	1	1	1	1	1		

38 (5-7,17-18,23-28,30-36,40-46)
 39 (5-6,17-18,23-28,30-36,40-46)

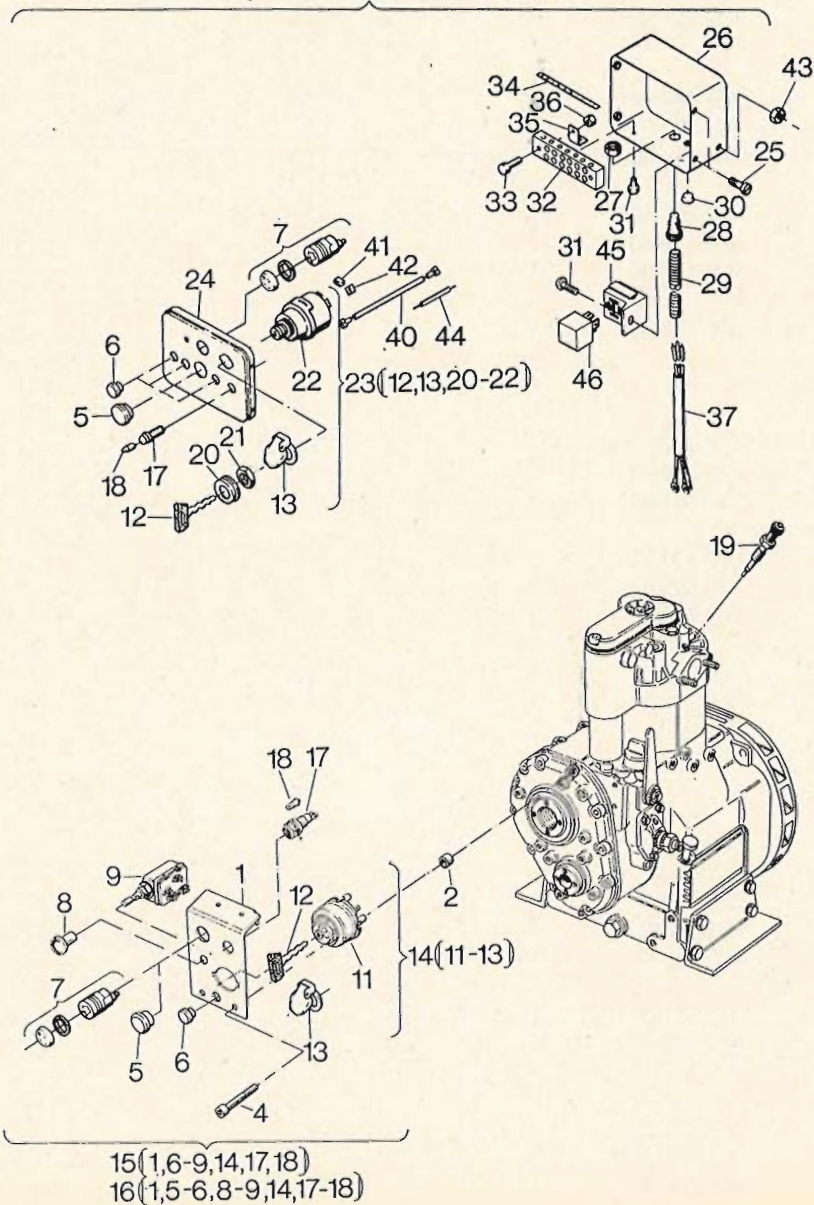

Fig. No.	Bestell-Nr. Ordering No. No. référence No. de pedido	Stück Quantity Quantités Cantidades					Hinweise Hints Indications Indicaciones	
		E 71	E 75	E 79	E 780	E 786		
33	501 588 00	2	2	2	2	2	M 4 x 20	DIN 84-4.8 A3C
34	038 862 00	1	1	1	1	1		
35	036 667 00	2	2	2	2	2		
36	501 471 00	2	2	2	2	2	M 4	DIN 934-8 A3C
37	—	—	—	—	—	—		
38	010 920 01	1	1	1	1	—		
39	010 961 01	—	—	—	—	1		
40	008 182 03	1	1	1	1	1		
41	502 766 00	1	1	1	1	1		
42	502 767 00	1	1	1	1	1	M 5	SSN 440-8 Cu
43	400 282 00	1	1	1	1	1		
44	011 501 01	1	1	1	1	1		
45	502 760 00	1	1	1	1	1		
46	502 777 01	1	1	1	1	1	12 V	

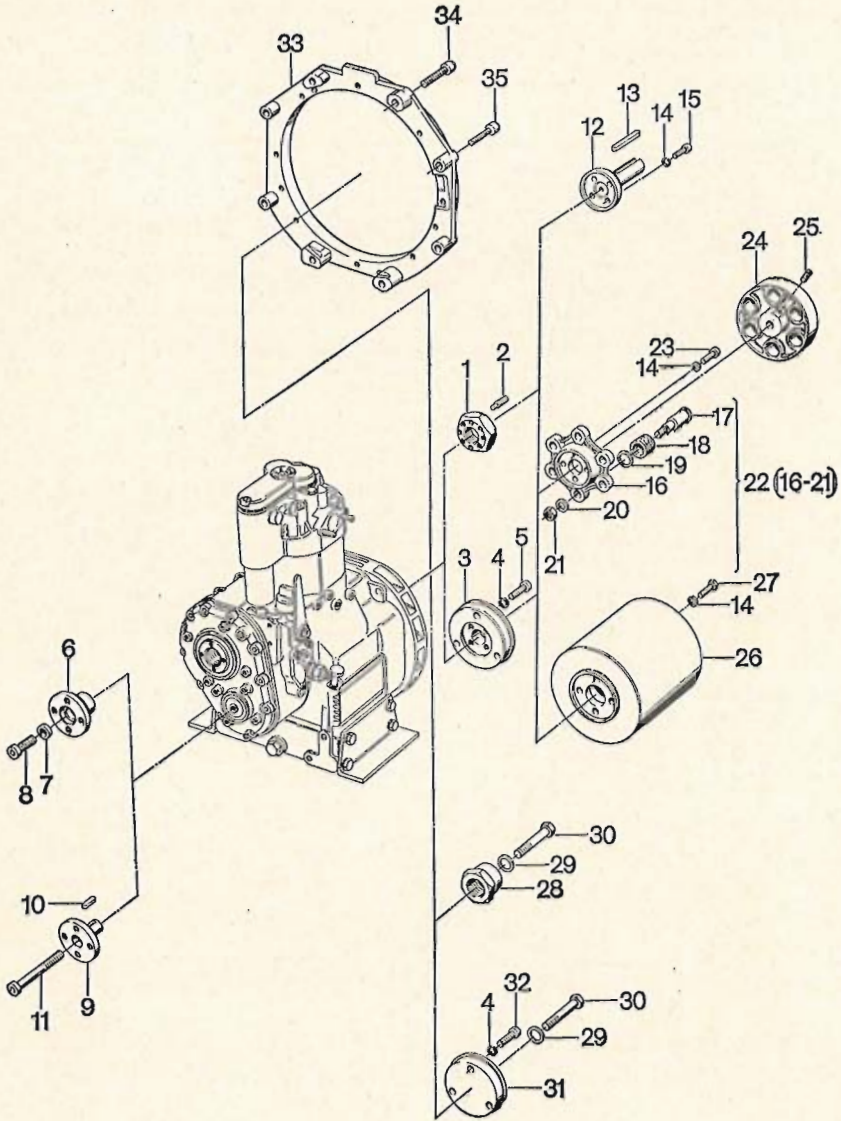

Fig. No.	Bestell-Nr. Ordering No. No. référence No. de pedido	Stück Quantity Quantites Cantidades					Hinweise Hints Indications Indicaciones	
		E 71	E 75	E 79	E 780	E 786		
1	030 114 00	1	1	—	—	—		
2	500 051 00	1	1	—	—	—	AM 10 x 25	DIN 915-45 H
3	030 175 00	—	—	1	1	1		
4	500 028 00	—	—	3	3	3	8	DIN 128
5	500 521 00	—	—	3	3	3	M 8 x 25	DIN 912 - 8.8
6	030 026 01	1	1	1	1	1		
7	031 699 01	1	1	1	1	1		
8	500 576 00	1	1	1	1	1	M 12x1,5x28	DIN 6912-10.9
9	031 003 01	—	—	—	1	1	U	
10	500 110 00	—	—	—	1	1	U A 6x4x22	DIN 6885
11	400 944 00	—	—	—	1	1	U M 12x1,5x65	DIN 6912-10.9
12	030 273 00	1	1	1	1	1		
13	500 117 00	1	1	1	1	1	A 8 x 7 x 63	DIN 6885
14	501 356 00	4	4	4	4	4	10	DIN 128 A3C
15	500 538 00	4	4	4	4	4	M 10 x 25	DIN 912 - 8.8
16	030 042 01	1	1	1	1	1		
17	003 072 00	6	6	6	6	6		
18	031 510 00	6	6	6	6	6		
19	030 790 00	6	6	6	6	6		
20	500 172 00	6	6	6	6	6	13	DIN 125 - St
21	500 239 00	6	6	6	6	6	M 12	DIN 934 - 8
22	003 418 01	1	1	1	1	1		
23	500 538 00	4	4	4	4	4	M 10 x 25	DIN 912-8.8 Zn
24	030 046 01	1	1	1	1	1		
25	500 046 00	1	1	1	1	1	AM 8 x 15	DIN 916-45 H
26	030 255 01	1	1	1	1	1	125 mm	
26	030 256 01	1	1	1	1	1	150 mm	
26	030 257 01	1	1	1	1	1	175 mm	
27	501 732 00	4	4	4	4	4	M 10 x 20	DIN 912-8.8 A3C
28	030 077 02	1	1	—	—	—		
28	030 136 01	—	—	1	1	—		
29	500 036 00	1	1	1	1	—	B 12	DIN 137
30	500 319 00	1	1	1	1	—	M 12 x 80	DIN 931 - 8.8
31	030 786 00	—	—	—	—	1		
32	500 521 00	—	—	—	—	3	M 8 x 25	DIN 912 - 8.8
33	036 633 00	—	—	—	1	—		
34	500 546 00	—	—	—	4	—	M 10 x 40	DIN 912 - 8.8
35	500 525 00	—	—	—	4	—	M 8 x 40	DIN 912 - 8.8

A 18

Anbauteile Hydraulikpumpe
Mount. parts hydr. pump
Pièces mont.-pompe hydr.
Piezas mont. bomba hidraulica

Tafel Nr.
Tabl. No.

20

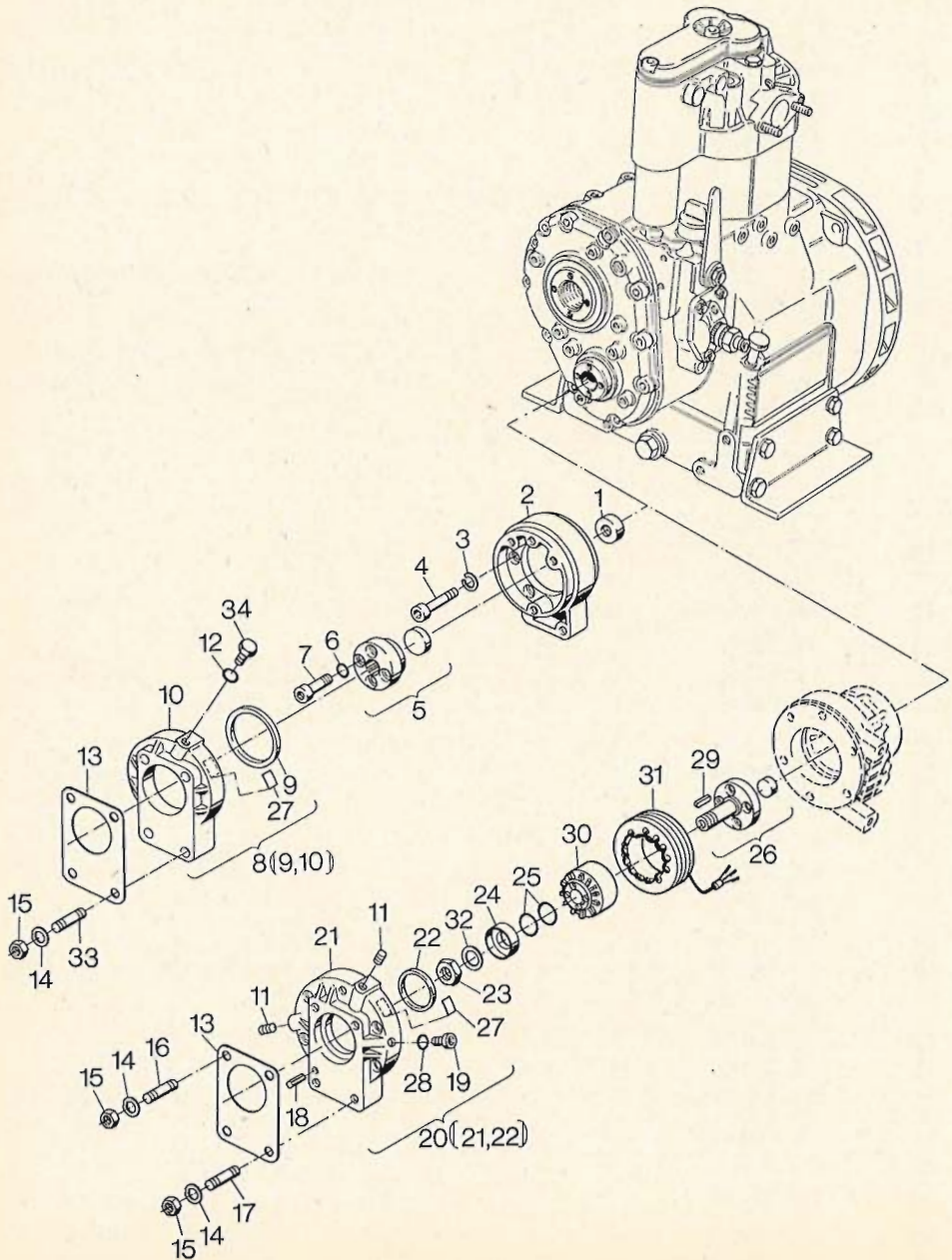

Fig. No.	Bestell-Nr. Ordering No. No. référence No. de pedido	Stück Quantity Quantites Cantidades					Hinweise Hints Indications Indicaciones	
		E 71	E 75	E 79	E 780	E 786		
1	039 036 00	1	1	1	1	1		
2	038 664 01	1	1	1	1	1	12,2x26x6	
3	500 028 00	4	4	4	4	4	8	DIN 128
4	500 521 00	4	4	4	4	4	M 8x25	DIN 912-8.8
5	011 226 00	1	1	1	1	1		
6	500 010 00	4	4	4	4	4	A 10x16	DIN 7603-Cu
7	500 535 00	4	4	4	4	4	M 10x16	DIN 6912-8.8
8	011 249 00	1	1	1	1	1		
9	502 866 00	1	1	1	1	1	70x90x7	
10	—	—	—	—	—	—		
11	500 043 00	2	2	2	2	2	M 8x10	DIN 553-5.8
12	501 629 00	2	2	2	2	2	A 8x14	DIN 7603-Cu
13	035 680 00	1	1	1	1	1		
14	500 951 00	4	4	4	4	4	A 8	DIN 137 A3C
15	501 480 00	4	4	4	4	4	M 8	DIN 934-8 A3C
16	500 377 00	2	2	2	2	2	M 8x20	DIN 939-5.6
17	500 375 00	2	2	2	2	2	M 8x20	DIN 835-5.8
18	500 124 00	1	1	1	1	1	5x24	DIN 1472
19	501 389 00	1	1	1	1	1	M 8x12	DIN 912-8.8 C4P
20	011 248 01	1	1	1	1	1		
21	—	—	—	—	—	—		
22	502 865 00	1	1	1	1	1	50x72x7	
23	038 666 00	1	1	1	1	1	M 24 x 1,5	
24	039 034 01	1	1	1	1	1		
25	502 864 00	1	1	1	1	1	A 24x29	DIN 7603-Cu
26	011 225 02	1	1	1	1	1		
27	039 130 00	1	1	1	1	1		
28	500 009 00	1	1	1	1	1	A 8x11,5	DIN 7603-Cu
29	503 436 00	1	1	1	1	1	A 5x3x25	DIN 6885
30	039 440 00	1	1	1	1	1		
31	503 455 00	1	1	1	1	1		
32	502 698 00	1	1	1	1	1	B 24	DIN 137
33	500 385 00	4	4	4	4	4	M 8x40	DIN 939-5.6
34	500 962 00	2	2	2	2	2	M 8x12	DIN 933-8.8 A3C

Anhang für nicht abgebildete Zusatzausrüstung:

Weitere Zusatzausrüstungen können aus Platzgründen in der Ersatzteilliste nicht mehr detailliert dargestellt werden. Für die Bestellung von Teilen aus nicht abgebildeten Zusatzausrüstungen verwenden Sie bitte nachfolgende Übersicht. Anhand der Skizze ist die gesuchte Zusatzausrüstung auffindbar, die für den jeweiligen Motortyp zugehörige Ident-Nr. der Ausrüstung ist aus der Tabelle ersichtlich. Ihre zuständige HATZ-Vertretung kann Ihnen anhand dieser Ident-Nr. das gewünschte Ersatzteil heraussuchen.

Annex for additional equipment which is not illustrated:

Due to lack of space we cannot list further additional equipment in our parts list: For parts ordering not illustrated, please use the below listed survey. With the aid of sketches you can find the required additional equipment. The Ident-number belonging to the corresponding engine type can be taken from the table. Your HATZ agent is in a position to select for you the required spare part as soon as you have selected the correct ident-number.

Annexe concernant les accessoires complémentaires non-illustrés:

Un certain nombre d'accessoires complémentaires n'ont pu, par suite d'un manque de place, être représentés d'une manière détaillée dans la liste de pièces détachées. Pour la commande de ces accessoires, qui ne sont pas illustrés, veuillez utiliser l'aperçu ci-après. A l'aide des croquis, il est possible de trouver l'accessoire souhaité, le No. ident. correspondant pour chaque type de moteur figure dans le tableau. Grâce à ce No. ident. votre représentant HATZ pourra vous trouver la pièce souhaitée.

En relación a equipos adicionales no ilustrados.

Debido a razones de espacio no es posible ilustrar otros equipos adicionales en la lista de piezas. Para pedidos de equipos adicionales no ilustrados favor usen la siguiente orientación. A base de las ilustraciones es posible encontrar el equipo adicional buscado, el número ident para el tipo de motor para el cual se necesita el equipo se puede obtener de la tabla.

El representante HATZ para su area puede entonces a base del número ident encontrar las piezas deseadas.

Zusatzausrüstungen
Equipements
Accessoires complémentaires
Equipos

Code

Ident-Nr.

E 71 / 75

E 79

E 780

E 786

Hinweise

Hints

Indications

Indications

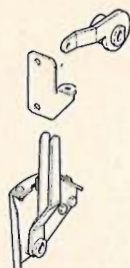

A 09.20	004 470 00	1	1	1	1	
A 09.20	004 647 00	—	—	1	1	E 780 U, E 786 U

A 09.40	004 472 02	1	1	1	1	
---------	------------	---	---	---	---	--



A 11.10	008 438 02	1	1	1	1	12 V
A 11.10	008 439 02	1	1	1	1	24 V



A 11.10	004 478 05	1	1	1	1	
---------	------------	---	---	---	---	--

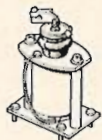

A 11.30	010 108 00	1	1	—	—	
---------	------------	---	---	---	---	--

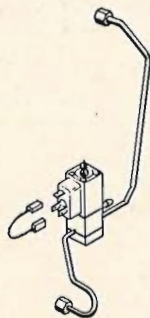

A 11.10	010 869 00	1	1	—	—	12 V
A 11.10	010 871 00	—	—	1	—	12 V
A 11.10	010 879 00	—	—	1	—	24 V
A 11.10	010 875 00	—	—	—	1	12 V

Zusatzausrüstungen

Equipements

Accessoires complémentaires

Equipos

Code

Ident-Nr.

E 71/75

E 79

E 780

E 786

Hinweise

Hints

Indications

Indications



A 12.10	004 455 02	1	1	1	—
A 12.10	005 944 01	—	—	1	1
A 12.10	006 714 01	—	—	1	—
A 12.10	006 280 01	—	—	—	1

E 780 U

E 786 U

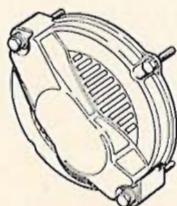

A 12.20	007 282 00	1	—	—	—
---------	------------	---	---	---	---

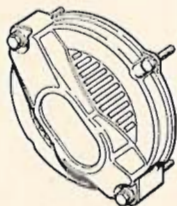

A 12.20	007 281 00	1	—	—	—
A 12.20	010 007 00	—	—	1	—



A 14.10	004 467 01	1	—	—	—
A 14.10	004 485 00	—	1	—	—

270 Ø

270 Ø



A 15.20	011 330 00	1	1	—	—
A 16.20	011 321 00	1	1	—	—
A 15.20	011 334 00	—	—	1	—
A 16.20	011 321 00	—	—	1	—
A 15.20	011 336 00	—	—	—	1
A 16.20	011 321 00	—	—	—	1

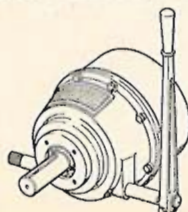

A 17.21	006 616 01	1	—	—	—
A 17.21	006 772 00	—	1	—	—
A 17.21	006 540 00	—	—	1	—

Zusatzrüstungen
Equipements
Accessoires complémentaires
Equipos

Code

Ident-Nr.

E 71/75

E 79

E 780

E 786

Hinweise

Hints

Indications

Indications

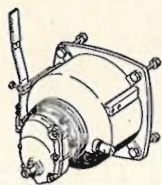

A 20.11	004 492 02	1	—	—	—	i = 1,8
A 20.11	004 488 01	1	—	—	—	i = 2,8
A 20.11	005 915 02	—	1	—	—	i = 1,8
A 20.11	005 917 01	—	1	—	—	i = 2,8
A 20.11	004 631 01	—	—	1	—	i = 1,8
A 20.11	003 992 00	—	—	1	—	i = 2,8
A 20.11	008 878 00	—	—	—	1	i = 1,8



A 21.11	004 497 00	1	—	—	—	i = 6,6
A 21.11	004 493 00	1	—	—	—	i = 10,4
A 21.11	005 918 00	—	1	—	—	i = 6,6
A 21.11	005 920 00	—	1	—	—	i = 10,4
A 21.11	004 633 00	—	—	1	—	i = 6,6
A 21.11	003 993 00	—	—	1	—	i = 10,4

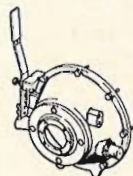

A 20.60	007 580 00/01	—	—	1	—
A 20.60	007 581 00/01	—	—	—	1

Serien-Nr.-Änderungen
Serial-code modification list
Modification des Nos de serien
Modificación de los Nos de serie

E 71

Bildtafel	Pos. Nr.	Bestell-Nr.	Stück	Bildtafel	Pos. Nr.	Bestell-Nr.	Stück	IMT No.
Table	Fig. No.	Ordering No.	Qty.	Table	Fig. No.	Ordering No.	Qty.	
Planche	Fig. No.	No. référence	Qté.	Planche	Fig. No.	No. référence	Qté.	
Tabla	Fig. No.	No. de pedido	Cant.	Tabla	Fig. No.	No. de pedido	Cant.	

E 71.15

E 71.16

81.334

10	11	036 135 00	1 ≠	10	11	036 623 00	1	
10	12	500 008 00	1 ≠	10	12	500 158 00	1	
10	13	036 136 00	1	—	—	—	—	
				10	27	036 737 00	1	
				10	28	008 055 00	1	
				10	29	036 636 00	1	
				10	30	501 578 00	1	
				10	31	036 637 00	1	
—	—	—	—	02	02	037 746 00	1	—
02	04	500 377 00	3	02	04	500 377 00	2	—
09	56	500 009 00	2	08	56	501 629 00	2	—
04	05	500 613 00	1	04	05	500 479 00	1	—
03	14	500 104 00	1	03	14	502 803 00	1	—
03	15	007 341 00	1	03	15	038 883 00	1	—
—	—	—	—	03	67	501 143 00	1	—
—	—	—	—	03	68	501 444 00	1	—
—	—	—	—	03	70	503 244 00	1	—
03	15	038 883 00	1	03	15	011 499 00	1	—
03	16	039 284 00	1	—	—	—	—	—
02	11	030 690 04	1	02	01	006 321 01	1	—
14	01	034 769 02	4	14	01	011 540 00	1	—
15	01	039 157 00	2	} 15	03	011 539 00	1	—
15	02	502 868 00	2					
—	—	—	—	17	50	039 439 00	1	88.480
17	30	010 824 01	1 ≠	17	51	503 455 00	1	
17	32	036 772 00	1 ≠	17	32	500 706 00	1	
17	33	502 698 00	1 ≠	17	33	502 451 00	1	
17	27	038 562 01	1 ≠	17	27	038 562 10	1	
—	—	—	—	17	49	500 108 00	1	
20	26	011 225 01	1 =	20	26	011 225 02	1	
—	—	—	—	20	29	503 436 00	1	
—	—	—	—	20	30	039 440 00	1	
—	—	011 591 00	1 =	20	31	503 455 00	1	
—	—	—	—	20	32	502 698 00	1	

Serien-Nr.-Änderungen
Serial-code modification list
Modification des Nos de serien
Modificación de los Nos de serie

E 75

Bildtafel	Pos. Nr.	Bestell-Nr.	Stück	Bildtafel	Pos. Nr.	Bestell-Nr.	Stück	IMT No.
Table	Fig. No.	Ordering No.	Qty.	Table	Fig. No.	Ordering No.	Qty.	
Planche	Fig. No.	No. référence	Qté.	Planche	Fig. No.	No. référence	Qté.	
Tabla	Fig. No.	No. de pedido	Cant.	Tabla	Fig. No.	No. de pedido	Cant.	

E 75.14

E 75.15

81.334

10	11	036 135 00	1	≠	10	11	036 623 00	1	
10	12	500 008 00	1	≠	10	12	500 158 00	1	
10	13	036 136 00	1	≠	—	—	—	—	
					10	27	036 737 00	1	
					10	28	008 055 00	1	
					10	29	036 636 00	1	
					10	30	501 578 00	1	
					10	31	036 637 00	1	
—	—	—	—		02	02	037 746 00	1	—
02	04	500 377 00	3		02	04	500 377 00	2	—
09	56	500 009 00	2		08	56	501 629 00	2	—
04	05	500 613 00	1		04	05	500 479 00	1	—
03	14	500 104 00	1		03	14	502 803 00	1	—
03	15	007 341 00	1		03	15	038 883 00	1	—
—	—	—	—		03	67	501 143 00	1	—
—	—	—	—		03	68	501 444 00	1	—
—	—	—	—		03	70	503 244 00	1	—
03	15	038 883 00	1		03	15	011 499 00	1	—
03	16	039 284 00	1	—	—	—	—	—	—
02	11	030 690 04	1		02	01	006 321 01	1	—
14	01	034 769 02	4		14	01	011 540 00	1	—
15	01	039 157 00	2	}	15	03	011 539 00	1	—
15	02	502 868 00	2						
									88.480
—	—	—	—		17	50	039 439 00	1	
17	30	010 824 01	1	≠	17	51	503 455 00	1	
17	32	036 772 00	1	≠	17	32	500 706 00	1	
17	33	502 698 00	1	≠	17	33	502 451 00	1	
17	27	038 562 01	1	≠	17	27	038 562 10	1	
—	—	—	—		17	49	500 108 00	1	
20	26	011 225 01	1	=	20	26	011 225 02	1	
—	—	—	—		20	29	503 436 00	1	
—	—	—	—		20	30	039 440 00	1	
—	—	011 591 00	1	=	20	31	503 455 00	1	
—	—	—	—		20	32	502 698 00	1	

Serien-Nr.-Änderungen
Serial-code modification list
Modification des Nos de serien
Modificación de los Nos de serie

E 79

Bildtafel	Pos. Nr.	Bestell-Nr.	Stück	Bildtafel	Pos. Nr.	Bestell-Nr.	Stück	IMT No.
Table	Fig. No.	Ordering No.	Qty.	Table	Fig. No.	Ordering No.	Qty.	
Planche	Fig. No.	No. référence	Qté.	Planche	Fig. No.	No. référence	Qté.	
Tabla	Fig. No.	No. de pedido	Cant.	Tabla	Fig. No.	No. de pedido	Cant.	

E 79.14

E 79.15

81.334

10	11	036 135 00	1 ≠	10	11	036 623 00	1	
10	12	500 008 00	1 ≠	10	12	500 158 00	1	
10	13	036 136 00	1 ≠	—	—	—	—	
				10	27	036 737 00	1	
				10	28	008 055 00	1	
				10	29	036 636 00	1	
				10	30	501 578 00	1	
				10	31	036 637 00	1	
				02	02	037 746 00	1	
02	04	500 377 00	3	02	04	500 377 00	2	—
09	56	500 009 00	2	08	56	501 629 00	2	—
03	14	500 104 00	1	03	14	502 803 00	1	—
03	15	007 341 00	1	03	15	038 883 00	1	—
—	—	—	—	03	67	501 143 00	1	—
—	—	—	—	03	68	501 444 00	1	—
—	—	—	—	03	70	503 244 00	1	—
03	15	038 883 00	1	03	15	011 499 00	1	—
02	11	030 690 04	1	02	01	006 321 01	1	—
14	01	034 769 02	4	14	01	011 540 00	1	—
15	01	039 157 00	2	15	03	011 539 00	1	—
15	02	502 868 00	2					

88.480

—	—	—	—	17	50	039 439 00	1	
17	30	010 824 01	1 ≠	17	51	503 455 00	1	
17	32	036 772 00	1 ≠	17	32	500 706 00	1	
17	33	502 698 00	1 ≠	17	33	502 451 00	1	
17	27	038 562 01	1 ≠	17	27	038 562 10	1	
—	—	—	—	17	49	500 108 00	1	
20	26	011 225 01	1 =	20	26	011 225 02	1	
—	—	—	—	20	29	503 436 00	1	
—	—	—	—	20	30	039 440 00	1	
—	—	011 591 00	1 =	20	31	503 455 00	1	
—	—	—	—	20	32	502 698 00	1	

Serien-Nr.-Änderungen
Serial-code modification list
Modification des Nos de serien
Modificación de los Nos de serie

E 780

Bildtafel	Pos. Nr.	Bestell-Nr.	Stück	Bildtafel	Pos. Nr.	Bestell-Nr.	Stück	IMT No.
Table	Fig. No.	Ordering No.	Qty.	Table	Fig. No.	Ordering No.	Qty.	
Planche	Fig. No.	No. référence	Qté.	Planche	Fig. No.	No. référence	Qté.	
Tabla	Fig. No.	No. de pedido	Cant.	Tabla	Fig. No.	No. de pedido	Cant.	

E 780.14

10	11	036 135 00	1	≠
10	12	500 008 00	1	≠
10	13	036 136 00	1	≠
—	—	—	—	—
02	04	500 377 00	3	
09	56	500 009 00	2	
03	14	500 104 00	1	
03	15	007 341 00	1	
—	—	—	—	
—	—	—	—	
—	—	—	—	
03	15	038 883 00	1	
02	11	030 690 04	1	
14	01	034 769 02	4	
15	01	039 157 00	2	}
15	02	502 868 00	2	

E 780.15

11	036 623 00	1	
12	500 158 00	1	
—	—	—	
10	036 737 00	1	
10	008 055 00	1	
10	036 636 00	1	
10	501 578 00	1	
10	036 637 00	1	
02	037 746 00	1	—
02	500 377 00	2	—
08	501 629 00	2	—
03	502 803 00	1	—
03	038 883 00	1	—
03	501 143 00	1	—
03	501 444 00	1	—
03	503 244 00	1	—
03	011 499 00	1	—
02	006 321 01	1	—
14	011 540 00	1	—
15	011 539 00	1	—

81.334

88.480

—	—	—	—	17	50	039 439 00	1	
17	30	010 824 01	1	≠	17	51	503 455 00	1
17	32	036 772 00	1	≠	17	32	500 706 00	1
17	33	502 698 00	1	≠	17	33	502 451 00	1
17	27	038 562 01	1	≠	17	27	038 562 10	1
—	—	—	—	17	49	500 108 00	1	
20	26	011 225 01	1	=	20	26	011 225 02	1
—	—	—	—	20	29	503 436 00	1	
—	—	—	—	20	30	039 440 00	1	
—	—	011 591 00	1	=	20	31	503 455 00	1
—	—	—	—	20	32	502 698 00	1	

Serien-Nr.-Änderungen
Serial-code modification list
Modification des Nos de serien
Modificación de los Nos de serie

E 786

Bildtafel	Pos. Nr.	Bestell-Nr.	Stück	Bildtafel	Pos. Nr.	Bestell-Nr.	Stück	IMT No.
Table	Fig. No.	Ordering No.	Qty.	Table	Fig. No.	Ordering No.	Qty.	
Planche	Fig. No.	No. référence	Qté.	Planche	Fig. No.	No. référence	Qté.	
Tabla	Fig. No.	No. de pedido	Cant.	Tabla	Fig. No.	No. de pedido	Cant.	

E 786.10

E 786.11

85.447

03	22	030 084 05	1	03	22	010 603 00	1	
11	09	502 571 00	1	10	09	502 571 10	1	
11	35	502 572 00	1	10	35	502 572 10	1	
11	34	502 576 00	1	10	34	502 576 10	1	
01	04	012 010 00	1	01	04	012 010 01	1	
03	14	500 104 00	1	03	14	502 803 00	1	—
03	15	007 341 00	1	03	15	038 883 00	1	—
—	—	—	—	03	67	501 143 00	1	—
—	—	—	—	03	68	501 444 00	1	—
—	—	—	—	03	70	503 244 00	1	—
03	15	038 883 00	—	03	15	011 499 00	1	—
02	11	030 690 04	—	02	01	006 321 01	1	—
14	01	032 300 00	1 =	14	01	011 587 00	1	—

88.480

—	—	—	—	17	50	039 439 00	1	
17	30	010 824 01	1 ≠	17	51	503 455 00	1	
17	32	036 772 00	1 ≠	17	32	500 706 00	1	
17	33	502 698 00	1 ≠	17	33	502 451 00	1	
17	27	038 562 01	1 ≠	17	27	038 562 10	1	
—	—	—	—	17	49	500 108 00	1	
20	26	011 225 01	1 =	20	26	011 225 02	1	
—	—	—	—	20	29	503 436 00	1	
—	—	—	—	20	30	039 440 00	1	
—	—	011 591 00	1 =	20	31	503 455 00	1	
—	—	—	—	20	32	502 698 00	1	