

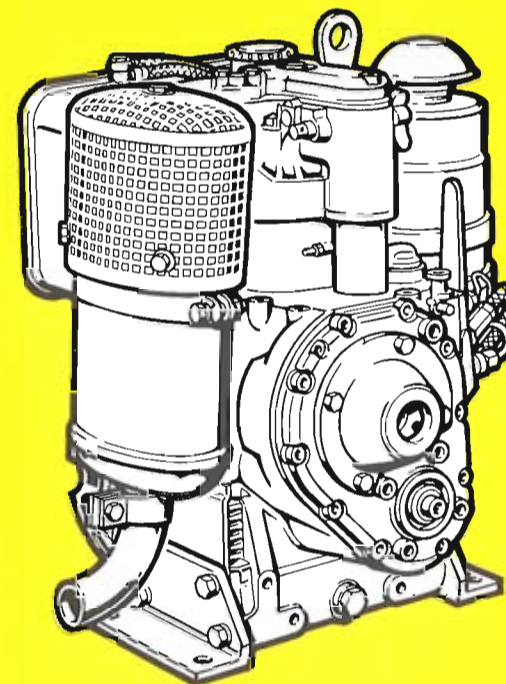

MOTORENFABRIK HATZ • D-94099 Ruhstorf • Germany
Tel.: 0 85 31 / 319-0 • Telex: 57260 • Telefax: 0 85 31 / 31 94 18

Original-Ersatzteile

Original-spare parts
Pièces de rechange d'origine
Repuestos originales



- E 71
- E 75
- E 79
- E 780
- E 786

434 100 00 -12.95 - 7.5
Printed in Germany

DM 3.-

Bestellung für HATZ-Original-Ersatzteile

Order for HATZ Original spare parts

Commande de pièces d'origine HATZ

Pedido de repuestos originales HATZ

1

Besteller / Customer / Client / Cliente

2

TYP	KENNZ.
MOTOR/FABRIK NO.	
MIN-1	



3

Ersatzteilliste Nr./ Spare parts list no./ Liste des pièces de rechange no./ Lista de repuestos No.

E 71.16 E 75.15 E 79.15
E 780.15 E 786.11

4

Stück / Qty	HATZ Ident No.	Stück / Qty	HATZ Ident No.

5

Versandart / Mode of dispatch / Mode d'expédition / Despacho deseado

Post / Surface / Poste / Correo Luftfracht / airfreight / frêt aérien / flete aereo
Express / express / exprès / expreso

6

Versandadresse / Consignee / Adresse destination / Dirección

Bestellung an: Order at: Commande à: Pedido a:
- die nächste HATZ-Servicestelle (siehe Servicestellenverzeichnis)
- your nearest HATZ service station (see service-list)
- votre station-service HATZ la plus proche (voir liste "Service")
- al servicio HATZ más cercano (ver cuaderno de Servicio)

MOTORENFABRIK HATZ
D-94099 RUHSTORF
Tel: 0 85 31 / 319 - 0
Fax: 0 85 31 / 31 94 21

Inhaltsverzeichnis		Index	Tafel-Nr. Table No.
M ..	Grundmotor	Basic engine	
00	Ersatzteilsätze,	Spare parts kits,	01
34	Zubehör, Schilder	accessories, labels	02
01	Kurbelgehäuse	Crankcase	03
01	Kurbelgehäuse	Crankcase	04
02, 03	Kurbelwelle, Lagerflansch	Crankshaft, bearing flange	05
04	Nockenwelle,	Camshaft,	06
05, 06	Kolben, Pleuel, Zylinder	Piston, conrod, cylinder	07
07	Zylinderkopf	Cylinder head	08
07	Zylinderkopf	Cylinder head	09
09, 11	Stoßstangen, Steuerdeckel	Pushrod, timing cover	10
14	Einspritzausrüstung	Injection equipment	11
17, 26	Schwungräder, Verschalung	Flywheels, cowling	12
A ..	Zusatzausrüstung	Equipements	
01	Kraftstoffbehälter	Fuel tank	13
01	Kraftstofffilter	Fuel filter	14
02	Luftfilter	Air filter	15
03	Abgasschalldämpfer	Exhaust silencer	16
04	Andrehkurbel, Andrehvorrichtung schs.	Starting handle, starting device, flywheel side	17
05	Starter, Generator	Starter, alternator	18
05	Armaturen	Electric equipment	19
16	Anschlußgehäuse, elast. Kupplung, Wellenstummel	Intermed. housing, flexible coupling, stubshaft	20
17	Kupplung kurz ausrückbar	Clutch short discon.	21 / 22
18	Anbauteile Hydraulikpumpe	Mount. parts hydr. pump	23 / 24
			Seite/Page
	Zusatzausrüstungen	Equipements	88 – 91
	Serien-Nr.-Änderungen	Serial-code modification list	92 – 96

Sommaire

Indice

M ..	Moteur de base	Motor de base	
00	Jeu de pièces de rechange,	Juegos de recambios,	01
34	accessoires, plaques	accessorios, placas	02
01	Carter moteur	Caja cigueñal	03
01	Carter moteur	Caja cigueñal	04
02, 03	Vilebrequin, palier	Cigueñal, brida de cojinete	05
04	Arbre à cames,	Arbol de levas,	06
05, 06	Piston, bielle, cylindre	Embolo, biela, cilindro	07
07	Culasse	Culata	08
07	Culasse	Culata	09
09, 11	Tige de culbuteur, couverture distribution	Varilla de balancín, tapa de mando	10
14	Equipement d'injection	Equipo de inyección	11
17, 26	Volants, tole refroid.	Volantes, revestimiento	12

A ..	Accessoires	Equipos	
01	Reservoir à carburant	Depósito combustible	13
01	Filtre à carburant	Filtro de combustible	14
02	Filtre à air	Filtro de aire	15
03	Silencieux	Silenciador	16
04	Manivelle, dispositif demarrage	Manivela, dispositivo de arranque	17
05	Demarreur, alternateur	Arrancador, alternador	18
05	Electrique equipement	Equipo eléctrico	19
16	Bride intermediere, accouplem. elast. bout d'arbre,	Caja de conexion, acoplamiento elast., eje	20
17	Embrayage debr. cout.	Embrague momentano	21 / 22
18	Pièces mont. pompe hydr.	Piezas mont. bomba hidraulica	23 / 24

Page/Página No

Accessoires complementaires Equipos 88 – 91

Modification des Nos de serien Modificación de los Nos de serie 92 – 96

M00

Ersatzteilsätze
Spare part kits
Jeux de pièces de rechange
Juegos de piezas de recambios
Serie guarnizioni

Tafel Nr.
Tabl. No.
Tavola N.

01

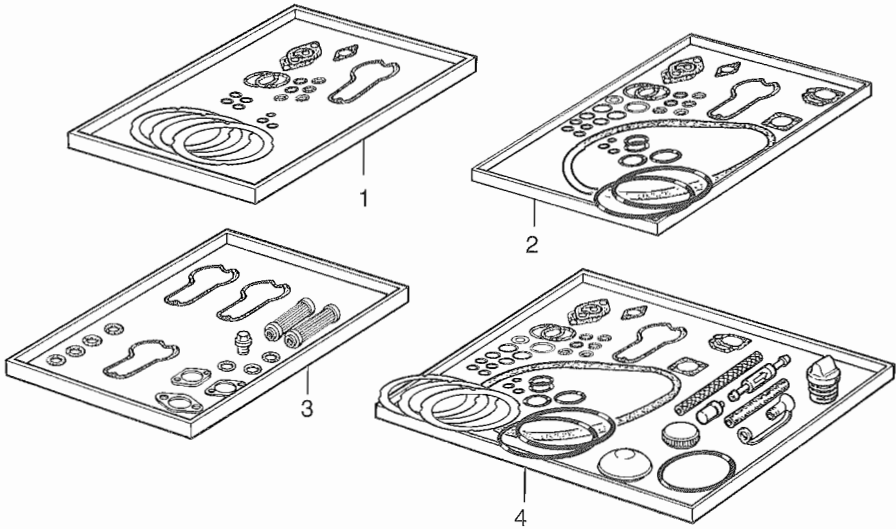

Fig.- No.	HATZ Ident-No.	Stück Qty.	P / W d / D	Bemerkungen Notes
--------------	-------------------	---------------	----------------	----------------------

E 71 E 75 E 79 E780 E786

W: Im Wartungssatz enthalten.

Incl. in maintenance kit.

Contenu dans le jeu d'entretien.

Incluido en el juego de mantenimiento.

d: Im Dichtungssatz für 1 Zyl.-Kopf enthalten.

Incl. in gasket set for 1 cylinder head.

Contenu dans le jeu de joint p. 1 culasse.

Incluido en el juego de juntas p. 1 culata.

P: Im Pannensatz enthalten.

Incl. in emergency kit.

Contenu dans le jeu secour.

Incluido en el juego para averias.

D: Im Dichtungssatz Kurbelgehäuse

Incl. in gasket set crankcase.

Contenu dans le jeu de joints

carter moteur

Incluido en el juego de juntas

caja cigüeñal.

1: Anzahl pro Satz - Qty. per kit

Quantite par jeu

Cantidad por juego

1	00339410	1	1	-	-	-	P1	Dichtungssatz für 1 Zylinderkopf
1	00355210	-	-	1	1	-	P1	Gasket set for 1 cyl. head
1	00358910	-	-	-	-	1	P1	Jeu de joint p. 1 culasse Juego de juntas para 1 culata
2	01229800	1	1	1	1	-		Dichtungssatz für Kurbelgehäuse
2	01229900	-	-	-	-	1		Gasket set for crankcase Jeu de joints p. carter moteur Juego de juntas para caja cigueñal
3	00961302	1	1	1	1	-		Wartungssatz für 1000 h
3	00961402	-	-	-	-	1		1000 hours maintenance kit Kit d'entretien 1000 heures Juego de piezas para servicio 1000 horas
4	00965704	1	1	-	-	-		Pannensatz - Emergency kit
4	00965804	-	-	1	-	-		Kit de secours
4	00965904	-	-	-	1	-		Juego para averias
4	01201003	-	-	-	-	1		

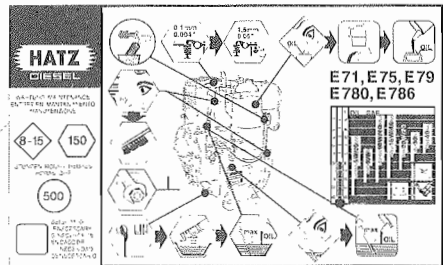
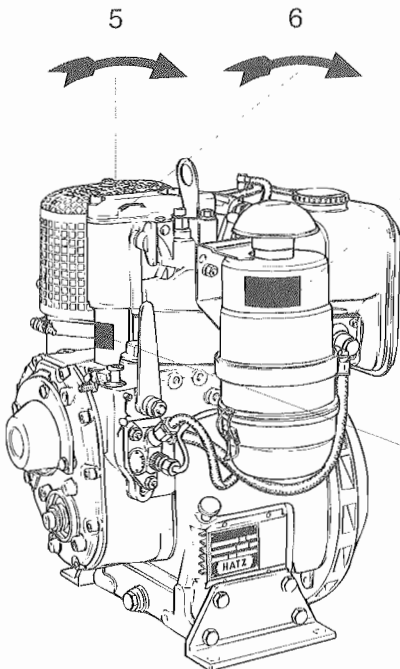
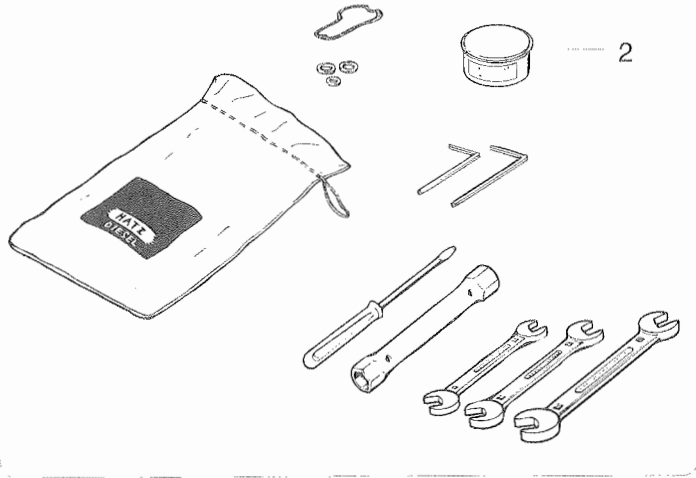

Achtung!
Dekompressions-
hebel nur in Pfeil-
richtung drehen.

Attention!
Turn decompression-
lever in the direction
of arrow only.

Attention!
Tourner levier de
décompression
seulement en direc-
tion de la flèche.

Fig.- No.	HATZ Ident-No.	Stück Qty.					P / W d / D	Bemerkungen Notes
		E 71	E 75	E 79	E780	E786		
1	00431701	1	1	1	1	-	Zubehörsatz - Accessoires kit	
1	00998100	-	-	-	-	1	Sort. accessoires	
2	40037000	1	1	1	1	-	Juego de accesorios	
3	03631201	1	1	1	1	1		
4	03396301	1	1	1	1	1		
5	03396700	1	1	1	1	1		
6	03589000	1	1	1	1	1		

Dicht- und Klebstoffe
Sealing- and bonding adhesives

Etanchéifiant et Colle
Materias para empaquetar y pegar

A = 502 230 01	Loctite Activator N	500 ml	} siehe Hinweis auf den einzelnen Bildtafeln as specified in the individual tables suivant les remarques sur les tableau correspondant según las indicaciones de las tablas correspondientes
B = 502 231 00	Loctite 573	50 ml	
C = 502 232 00	Loctite 601	50 ml	
D = 502 233 00	Loctite 221	50 ml	
E = 502 234 00	Loctite 648	10 ml	
F = 502 238 00	Technicoll 8058	0,75 kg	
+ 502 239 00	Technicoll 8367	0,75 kg	
G = 502 565 01	Loctite IS 407	20 ml	
H = 502 825 01	Silicon	30 ml	
J = 502 830 02	Hochtemp. Paste	1000 g	

M 01

Kurbelgehäuse
Crankcase
Carter moteur
Caja cigueñal
Basamento motore

Tafel Nr.
Tabl. No.
Tavola N.

03

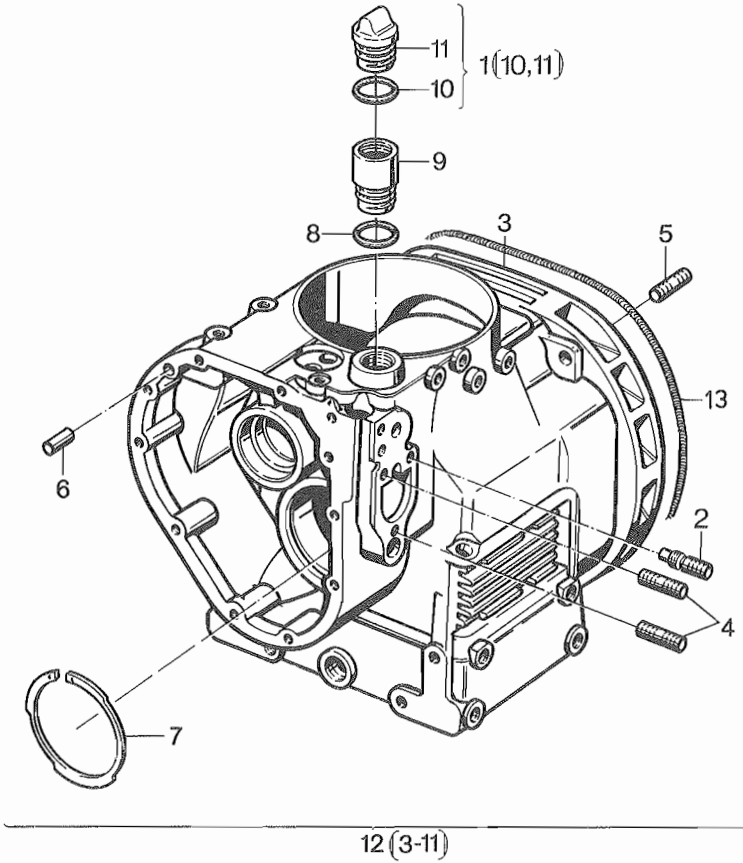

Fig.- No.	HATZ Ident-No.	Stück Qty.					P / W d / D	Bemerkungen Notes
		E 71	E 75	E 79	E780	E786		
1	00632101	1	1	1	1	1	W1	
2	03774600	1	1	1	1	1		
3	-----	-	-	-	-	-		
4	50037700	2	2	2	2	2		M 8 x 20 DIN 939-5.6
5	50037300	6	6	6	10	10		M 8 x 18 DIN 835-10.9
6	03169300	1	1	1	1	1		
7	40027600	1	1	1	1	1		
8	50153800	1	1	1	1	1		
9	03658400	1	1	1	1	1		
10	50153800	1	1	1	1	1	D1	
11	-----	-	-	-	-	-		
12	00355402	1	1	1	-	-		
12	00356703	-	-	-	1	-		
12	00359102	-	-	-	-	1		
13	03615600	1	1	1	-	-		

M 01

Kurbelgehäuse
Crankcase
Carter moteur
Caja cigueñal
Basamento motore

Tafel Nr.
Tabl. No.
Tavola N.

04

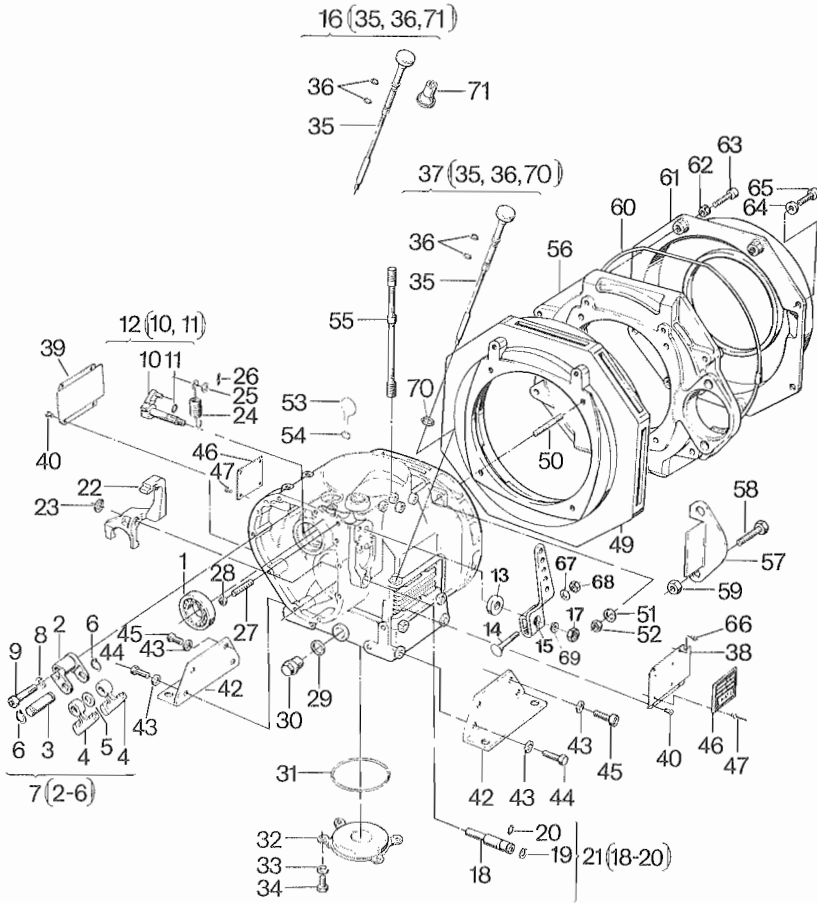

Fig.- No.	HATZ Ident-No.	Stück Qty.					P / W d / D	Bemerkungen Notes
		E 71	E 75	E 79	E780	E786		
1	50014200	1	1	1	1	1		
2	03009100	1	1	1	1	1		
3	03168800	1	1	1	1	1		
4	03009002	2	2	2	2	2		
5	03169400	0..1	0..1	0..1	0..1	0..1		0,1 mm
5	03169600	0..1	0..1	0..1	0..1	0..1		0,2 mm
5	03169700	0..1	0..1	0..1	0..1	0..1		0,3 mm
5	03169800	0..1	0..1	0..1	0..1	0..1		0,5 mm
6	50019500	2	2	2	2	2		12 x 1 DIN 471
7	00339600	1	1	1	1	1		
8	50002900	1	1	1	1	1		10 DIN 128
9	03170400	1	1	1	1	1		
10	-----	-	-	-	-	-		
11	40022300	1	1	1	1	1	D2	
12	00300200	1	1	1	1	1		
13	03146201	1	1	1	1	1		
14	03927300	1	1	1	1	1		M 6 x 32
15	01149900	1	1	1	1	1		
16	01242500	-	-	-	1	1		n > 1800 / 1500 min ⁻¹
16	01242600	-	-	-	1	-		n ≤ 1800 min ⁻¹
16	01242600	-	-	-	-	1		n ≤ 1500 min ⁻¹
17	40028600	1	1	1	1	1		M 10 SSN 440-8 Cu
18	-----	-	-	-	-	-		
19	40031000	1	1	1	1	1		
20	40022300	1	1	1	1	1	D2	
21	00557900	1	1	1	1	1		
22	01060300	-	-	-	-	1		Federanschlag, spring stop, arrête de ressort, arresto a molla
22	03008405	1	1	1	1	-		
23	50019400	1	1	1	1	1		8 x 0,8 DIN 471
24	03194902	1	1	1	1	-		2,1 mm Ø ≤ 2100 min ⁻¹
24	03770800	-	-	-	-	1		2,0 mm Ø ≤ 2100 min ⁻¹
24	03769900	-	-	-	-	1		2,4 mm Ø > 2100 min ⁻¹
24	03194801	1	1	1	1	-		2,6 mm Ø > 2100 min ⁻¹
25	03133200	1	1	1	1	1		
26	50036100	1	1	1	1	1		2 x 22 DIN 94

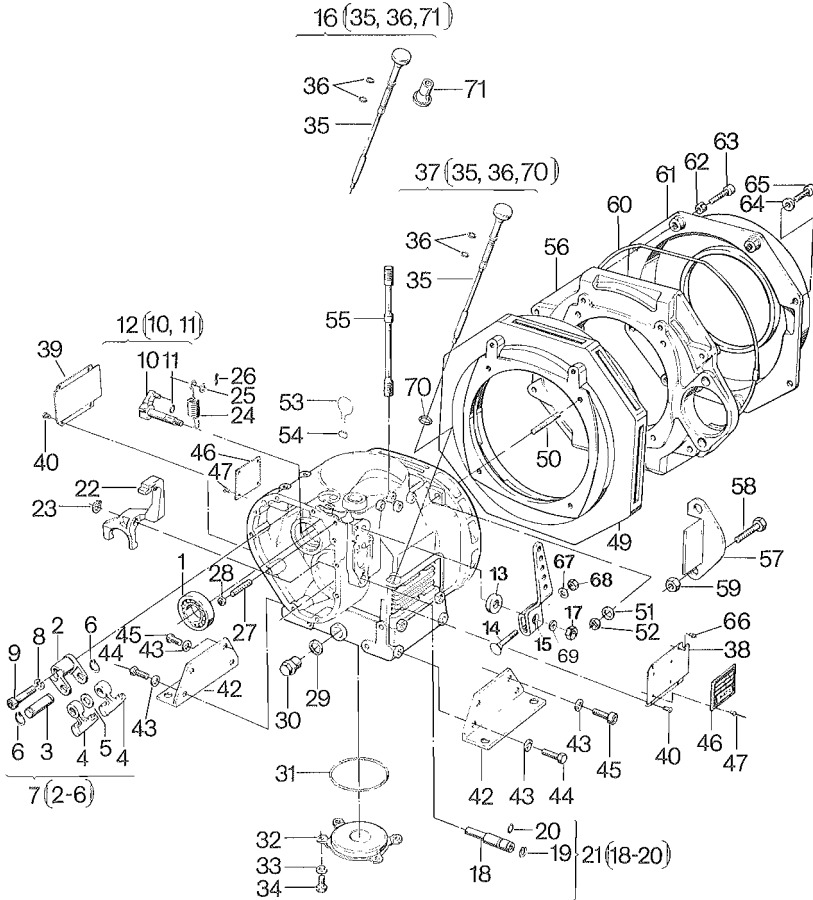

Fig.- No.	HATZ Ident-No.	Stück Qty.					P / W d / D	Bemerkungen Notes
		E 71	E 75	E 79	E780	E786		
27	03169501	1	1	1	1	1		
28	50023200	1	1	1	1	1		BM 8 DIN 439-5
29	50001500	1	1	1	1	1	W7,D1	A 21 x 26 DIN 7603-Cu
30	03169103	1	1	1	1	1	W1	
31	50222900	1	1	1	1	1	D2	
32	03003201	1	1	1	1	1		
33	50002800	4	4	4	4	4		8 DIN 128
34	50026700	4	4	4	4	4		M 8 x 16 DIN 933-8.8
35	-----	-	-	-	-	-		
36	40021700	2	2	2	2	2	D2	
37	00307102	1	1	1	-	-		
37	01069800	1	1	1	-	-		n ≤ 1500 min ⁻¹ Taf. / Tabl. 07, Pos. 18 - 21
38	03169200	1	1	1	1	1		
39	03169000	1	1	1	1	1		
40	50005500	8	8	8	8	6		3 x 12 DIN 1476
42	03007500	2	2	2	-	-		
42	03016500	-	-	-	2	2		
43	50002900	8	8	8	8	8		10 DIN 128
44	-----	-	-	-	-	-		
45	50054100	8	8	8	8	8		M 10 x 30 DIN 912-8.8
46	03225504	1	1	1	1	1		
47	40002500	4	4	4	4	4		
49	03200803	-	-	-	-	1		
50	50040800	-	-	-	4	4		M 10 x 28 DIN 939-10.9
51	50145900	-	-	-	4	4		B 10,5 DIN 125-St A3C
52	50023500	-	-	-	4	4		M 10 DIN 934-8
53	40021500	1	1	1	1	1		
54	40021400	1	1	1	1	1		
55	03171600	4	4	4	-	-		
55	03200100	-	-	-	4	-		
55	03203101	-	-	-	-	4		

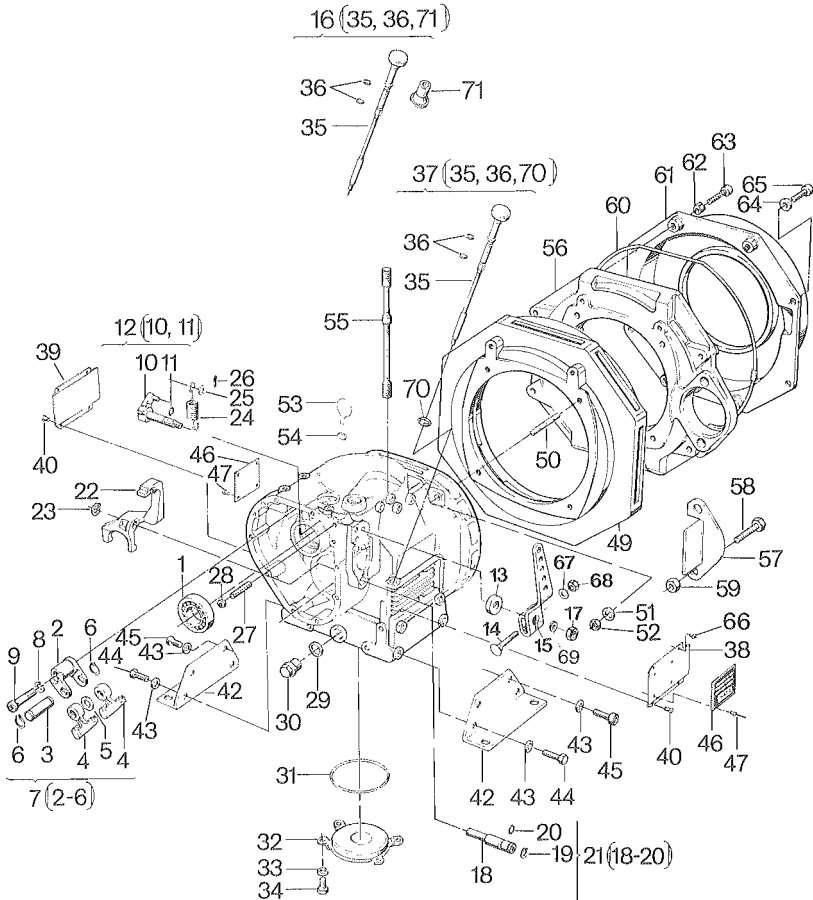

Fig.- No.	HATZ Ident-No.	Stück Qty.					P / W d / D	Bemerkungen Notes
		E 71	E 75	E 79	E780	E786		
56	03663200	-	-	-	1	-		
57	03663400	-	-	-	1	-		
58	50031400	-	-	-	2	-	M 12 x 40 DIN 933-8.8	
59	50023900	-	-	-	2	-	M 12 DIN 934-8	
60	03663000	-	-	-	1	-		
61	03684300	-	-	-	1	-		
62	03684500	-	-	-	4	-		
63	50053800	-	-	-	4	-	M 10 x 25 DIN 912-8.8	
64	03684400	-	-	-	4	-		
65	50052200	-	-	-	4	-	M 8 x 30 DIN 912-8.8	
66	50018300	-	-	-	-	2	3 x 12 DIN 1477	
67	50144500	1	1	1	1	1	6,4 DIN 125 A3C	
68	50346500	1	1	1	1	1	M 6 DIN 934-8 10.9	
69	50017200	1	1	1	1	1	13 DIN 125-St	
70	50324400	1	1	1	-	-		
71	04039100	-	-	-	1	1		

M 02

Kurbelwelle
Crankshaft
Vilebrequin
Cigüeñal
Albero a gomito

M 03

Lagerflansch
Bearing flange
Palier
Brida de cojinete
Supporto

Tafel Nr.
Tabl. No.
Tavola N.

05

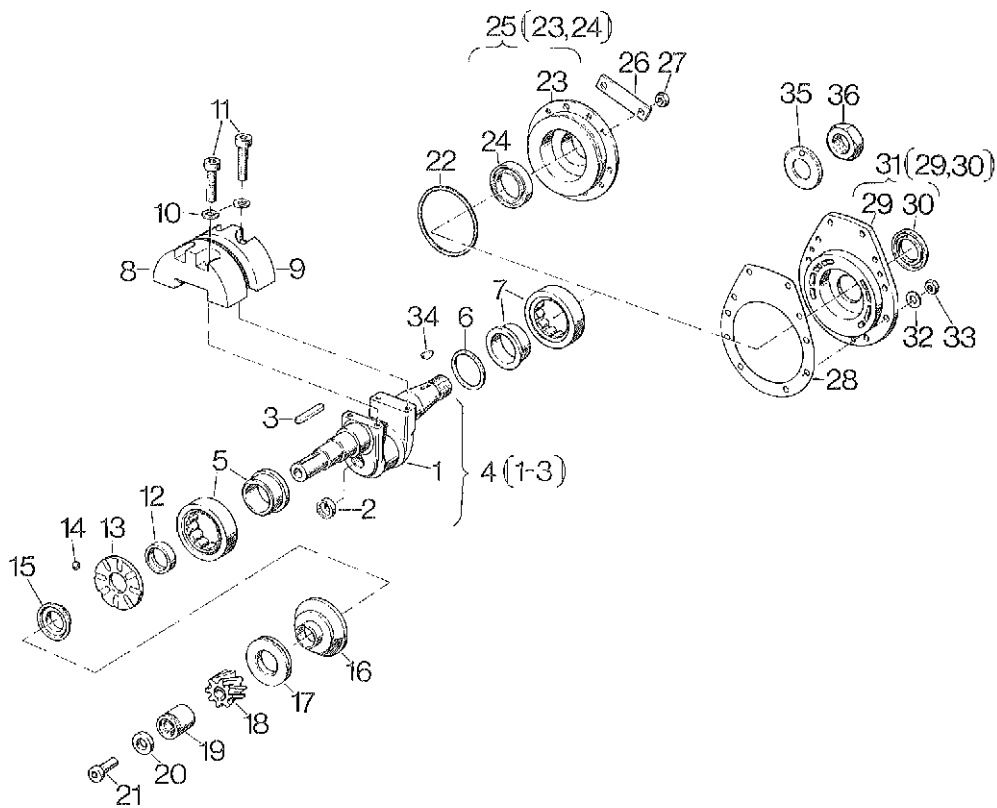

Fig.- No.	HATZ Ident-No.	Stück Qty.					P / W d / D	Bemerkungen Notes
		E 71	E 75	E 79	E780	E786		
1	-----	-	-	-	-	-		
2	03195000	1	1	1	1	-		
2	03201000	-	-	-	-	1		
3	03195100	1	1	1	1	1		
4	00355503	1	1	1	-	-		
4	00356802	-	-	-	1	-		
4	00359301	-	-	-	-	1		
5	50047900	1	1	1	1	1		
6	03195200	0..1	0..1	0..1	-	-	0,10 mm	
6	03195300	0..1	0..1	0..1	-	-	0,20 mm	
6	03195400	0..1	0..1	0..1	-	-	0,30 mm	
6	03195500	0..1	0..1	0..1	-	-	0,40 mm	
6	03195600	0..1	0..1	0..1	-	-	0,50 mm	
6	03198700	-	-	-	0..1	-	0,10 mm	
6	03198800	-	-	-	0..1	-	0,20 mm	
6	03198900	-	-	-	0..1	-	0,30 mm	
6	03199000	-	-	-	0..1	-	0,40 mm	
6	03199100	-	-	-	0..1	-	0,50 mm	
6	03201100	-	-	-	-	0..1	0,10 mm	
6	03201200	-	-	-	-	0..1	0,20 mm	
6	03201300	-	-	-	-	0..1	0,30 mm	
6	03201400	-	-	-	-	0..1	0,40 mm	
6	03201500	-	-	-	-	0..1	0,50 mm	
7	50047900	1	1	1	-	-		
7	50048100	-	-	-	1	-		
7	50048300	-	-	-	-	1		
8	03013102	1	1	1	-	-		
8	03015201	-	-	-	1	-		
8	03018600	-	-	-	-	1		
9	03437000	1	1	-	-	-		
9	03013202	-	-	1	-	-		
9	03015301	-	-	-	1	-		
9	03018700	-	-	-	-	1		
10	50002900	4	4	4	4	4	10 DIN 128	
11	50055000	4	4	4	4	-	M 10 x 50 DIN 912-10.9	
11	50055300	-	-	-	-	4	M 10 x 60 DIN 912-10.9	

M 02

Kurbelwelle
Crankshaft
Vilebrequin
Cigüeñal
Albero a gomito

M 03

Lagerflansch
Bearing flange
Palier
Brida de cojinete
Supporto

Tafel Nr.
Tabl. No.
Tavola N.

05

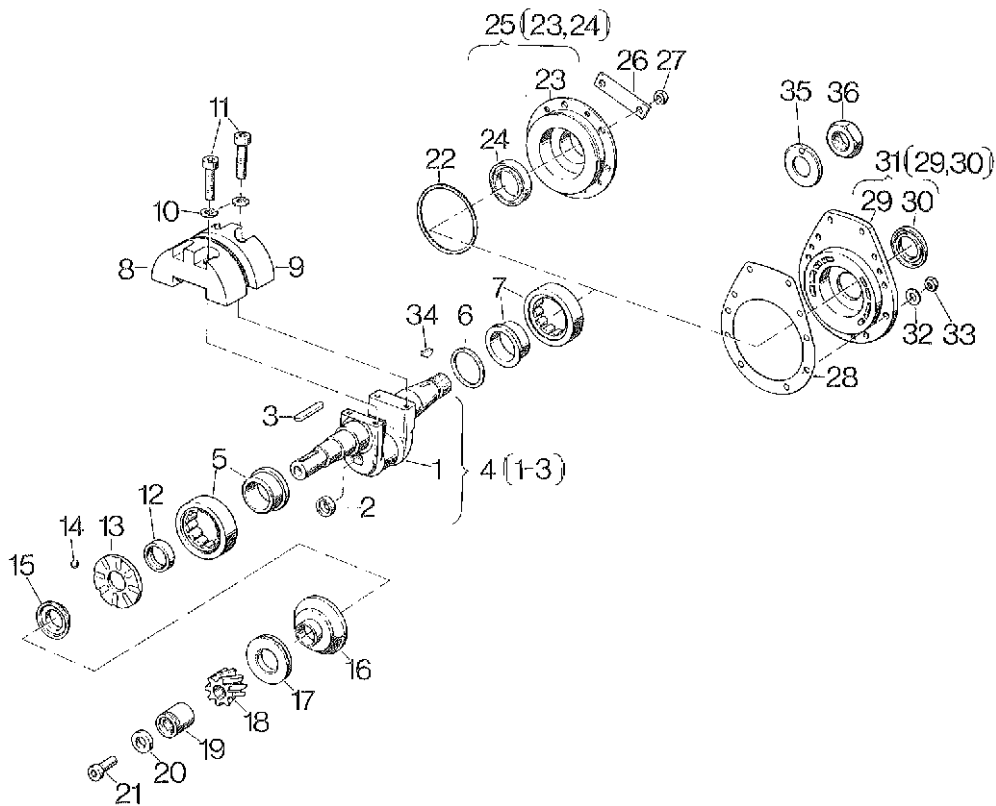

Fig.- No.	HATZ Ident-No.	Stück Qty.					P / W d / D	Bemerkungen Notes
		E 71	E 75	E 79	E780	E786		
12	03013000	1	1	1	1	1		
13	03006602	1	1	1	1	1		
14	50010000	8	8	8	8	8		
15	03170001	1	1	1	1	1		
16	00742000	1	1	1	1	-		
16	01213200	-	-	-	-	1		
17	03004501	1	1	1	1	1		
18	03001001	1	1	1	1	1		
19	03001601	1	1	1	1	1	E	
20	03169901	1	1	1	1	1	E	
21	50057600	1	1	1	1	1	M 12 x 1,5 x 28 DIN 6912-10.9	
22	50222900	1	1	1	-	-		
23	- - - - -	-	-	-	-	-		
24	40033900	1	1	1	-	-	D1	
25	00339802	1	1	1	-	-		
26	03279900	3	3	3	-	-		
27	50022900	6	6	6	-	-	M 8 DIN 934-8	
28	03199200	-	-	-	1	1	D1	
29	- - - - -	-	-	-	-	-		
30	40033900	-	-	-	1	-	D1	
30	40034100	-	-	-	-	1	D1	
31	00357000	-	-	-	1	-		
31	00359400	-	-	-	-	1		
32	03170100	-	-	-	10	10		
33	50022900	-	-	-	10	10	M 8 DIN 934-8	
34	50017800	1	1	1	1	-	4 x 6,5 DIN 6888	
34	50018100	-	-	-	-	1	8 x 11 DIN 6888	
35	03198600	1	1	1	1	-		
35	03200900	-	-	-	-	1		
36	03285500	1	1	1	1	-		
36	03285400	-	-	-	-	1		

M 04

Nockenwelle, Massenausgleich
Camshaft, compensation of masses
Arbre à cames, équilibrage
Arbol de levas, compensación de las masas
Albero a camme, masse equilibratura

Tafel Nr.
Tabl. No.
Tavola N.

06

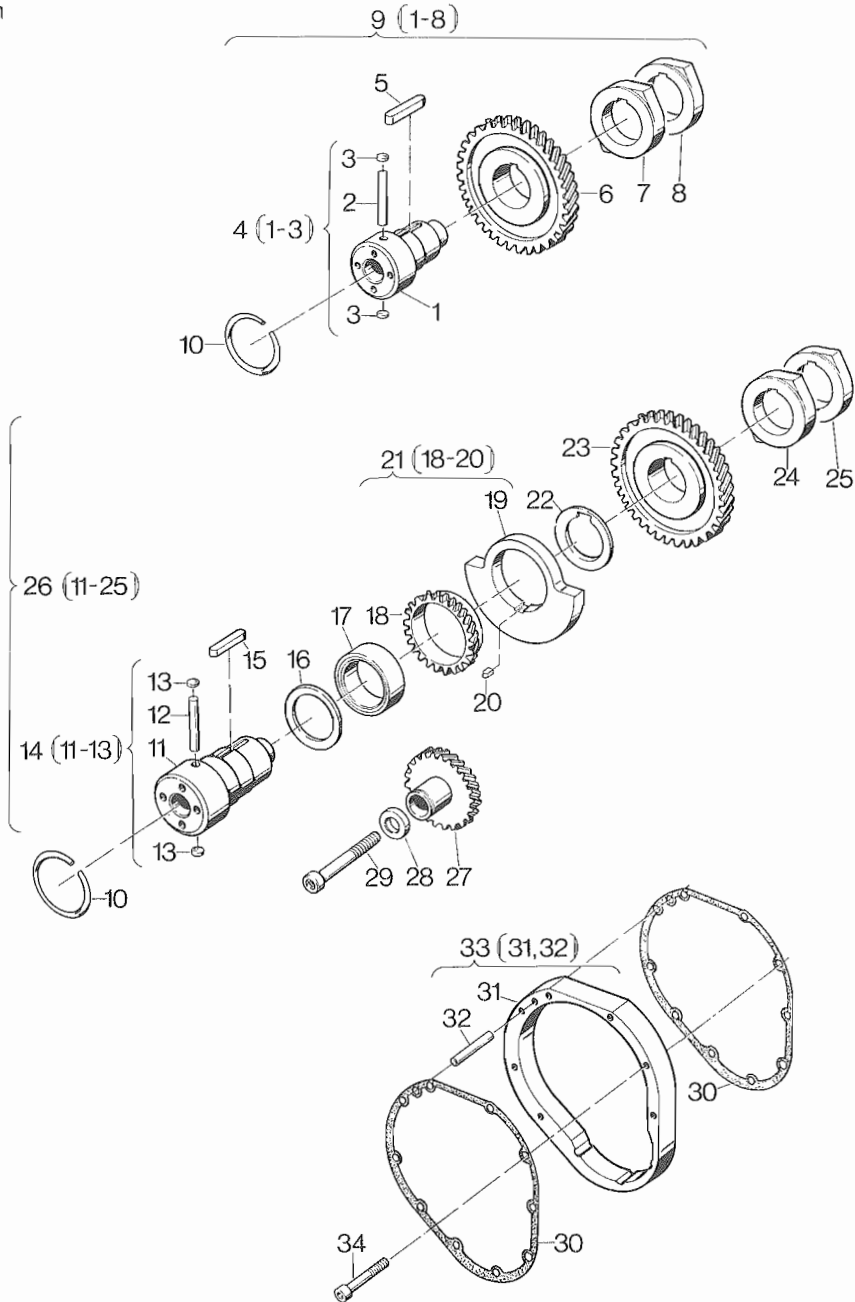

Fig.- No.	HATZ Ident-No.	Stück Qty.					P / W d / D	Bemerkungen Notes
		E 71	E 75	E 79	E780	E786		
1	-----	-	-	-	-	-		
2	03012600	1	1	1	1	1		
3	50043300	2	2	2	2	2	8 DIN 470	
4	00423304	1	1	1	1	1		
5	50011600	1	1	1	1	1	A 8 x 7 x 56 DIN 6885	
6	03000902	1	1	1	1	1		
7	03008305	1	1	1	1	1		
8	03008203	1	1	1	1	1		
9	00340002	1	1	1	1	1		
10	03170300	1	1	1	1	1		
11	-----	-	-	-	-	-		
12	03012600	-	-	-	1	1		
13	50043300	-	-	-	2	2	8 DIN 470	
14	00514500	-	-	-	1	1	U	
15	50011600	-	-	-	1	1	A 8 x 7 x 56 DIN 6885	
16	03256500	-	-	-	1	1	U	
17	40019600	-	-	-	1	1	U	
18	-----	-	-	-	-	-		
19	-----	-	-	-	-	-		
20	50170400	-	-	-	1	1	U A 6 x 4 x 12 DIN 6885	
21	00312900	-	-	-	1	-	U	
21	00312700	-	-	-	-	1	U	
22	03201600	-	-	-	1	1	U	
23	03000902	-	-	-	1	1		
24	03008305	-	-	-	1	1		
25	03008203	-	-	-	1	1		
26	00357102	-	-	-	1	-	U	
26	00359502	-	-	-	-	1	U	
27	03100001	-	-	-	1	1	U	
28	03169901	1	1	1	1	1		
29	40092200	-	-	-	1	1	U	
30	03174500	-	-	-	2	2	U	
31	-----	-	-	-	-	-		
32	50058600	-	-	-	1	1	8 m 6 x 50 DIN 7-9S20k	
33	00409600	-	-	-	1	1	U	
34	50052700	-	-	-	10	10	U M 8 x 50 DIN 912-8.8	

M 05

Kolben, Pleuel
Piston, conrod
Pistone, bielle
Embolo, biela
Pistone, biella

M 06

Zylinder
Cylinder
Cylindre
Cilindro
Cilindro

Tafel Nr.
Tabl. No.
Tavola N.

07

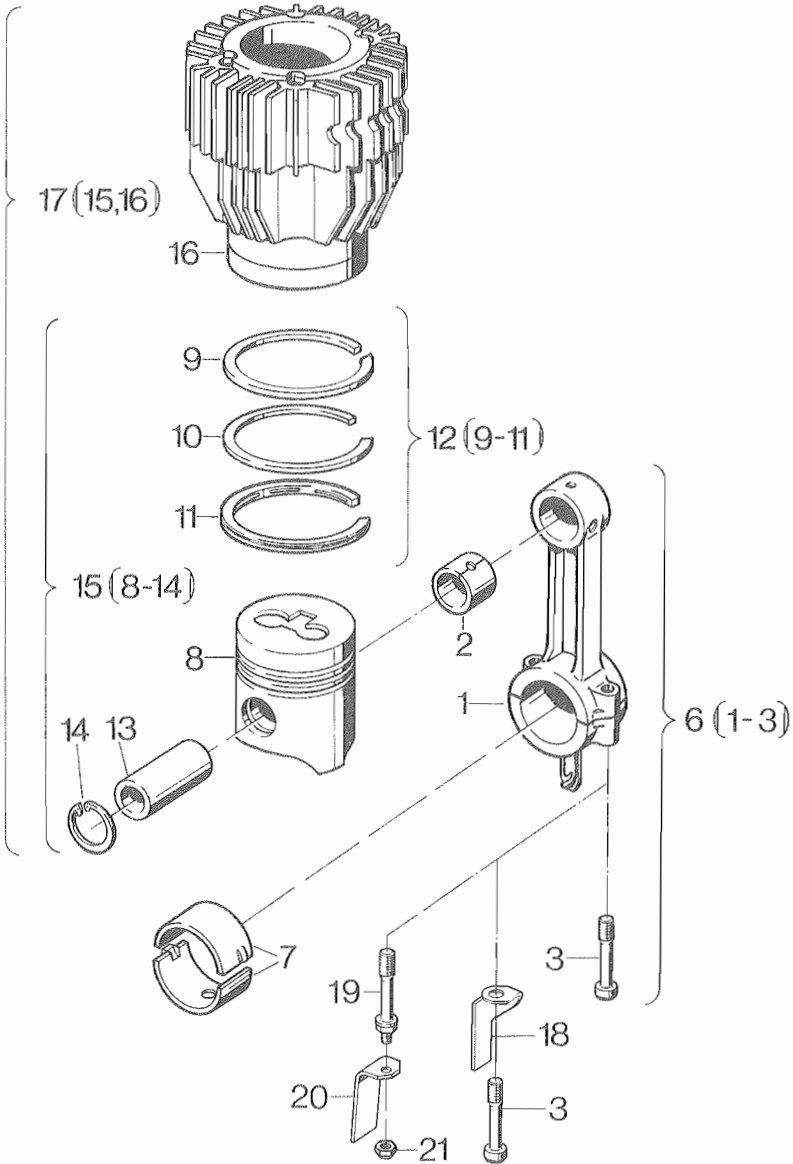

Fig.- No.	HATZ Ident-No.	Stück Qty.					P / W d / D	Bemerkungen Notes
		E 71	E 75	E 79	E780	E786		
1	-----	-	-	-	-	-		
2	03003001	1	1	-	-	-		
2	03012800	-	-	1	1	-		
2	03202000	-	-	-	-	1		
3	03170400	2	2	2	2	2		
4	-----	-	-	-	-	-		
5	-----	-	-	-	-	-		
6	00340301	1	1	-	-	-		
6	00355901	-	-	1	-	-		
6	00357401	-	-	-	1	-		
6	00359801	-	-	-	-	1		
7	03195700	1	1	1	1	-		
7	03195800	1	1	1	1	-	- 0,5 mm	
7	03201800	-	-	-	-	1		
7	03201900	-	-	-	-	1	- 0,5 mm	
8	-----	-	-	-	-	-		
9	-----	-	-	-	-	-		
10	-----	-	-	-	-	-		
11	-----	-	-	-	-	-		
12	00571410	1	1	-	-	-		
12	01234200	1	1	-	-	-	+ 0,5 mm	
12	00571510	1	1	-	-	-	+ 1,0 mm	
12	00573010	-	-	1	-	-		
12	01234400	-	-	1	-	-	+ 0,5 mm	
12	00573110	-	-	1	-	-	+ 1,0 mm	
12	00573203	-	-	-	1	-		
12	01234601	-	-	-	1	-	+ 0,5 mm	
12	00573303	-	-	-	1	-	+ 1,0 mm	
12	01273800	-	-	-	-	1		
12	01234801	-	-	-	-	1	+ 0,5 mm	
12	01274200	-	-	-	-	1	+ 1,0 mm	

M 05

Kolben, Pleuel
Piston, conrod
Piston, bielle
Embolo, biela
Pistone, biella

M 06

Zylinder
Cylinder
Cylindre
Cilindro
Cilindro

Tafel Nr.
Tabl. No.
Tavola N.

07

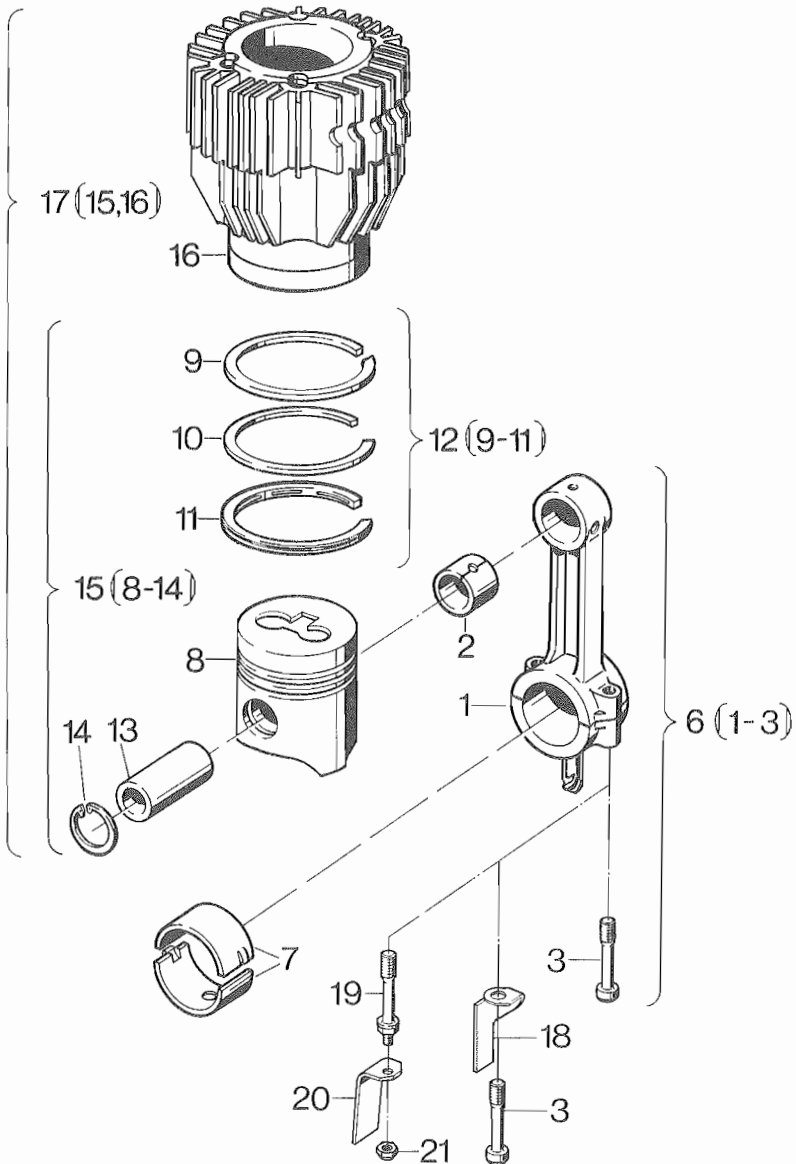

Fig.- No.	HATZ Ident-No.	Stück Qty.					P / W d / D	Bemerkungen Notes
		E 71	E 75	E 79	E780	E786		
13	50101800	1	1	-	-	-		
13	50108200	-	-	1	1	-		
13	50106400	-	-	-	-	1		
14	50020600	2	2	-	-	-	25 x 1,2 DIN 472	
14	50020700	-	-	2	2	-	28 x 1,2 DIN 472	
14	50020800	-	-	-	-	2	30 x 1,2 DIN 472	
15	00340104	1	1	-	-	-		
15	01234100	1	1	-	-	-	+ 0,5 mm	
15	00340204	1	1	-	-	-	+ 1,0 mm	
15	00356001	-	-	1	-	-		
15	01234300	-	-	1	-	-	+ 0,5 mm	
15	00356101	-	-	1	-	-	+ 1,0 mm	
15	00357203	-	-	-	1	-		
15	01234501	-	-	-	1	-	+ 0,5 mm	
15	00357303	-	-	-	1	-	+ 1,0 mm	
15	00997101	-	-	-	-	1		
15	01234701	-	-	-	-	1	+ 0,5 mm	
15	00997201	-	-	-	-	1	+ 1,0 mm	
16	-----	-	-	-	-	-		
17	00565700	1	1	-	-	-		
17	00566100	-	-	1	-	-		
17	00566201	-	-	-	1	-		
17	01200400	-	-	-	-	1		
18	03773301	1	1	1	-	-	n ≤ 1500 min ⁻¹	
18	03779300	-	-	-	1	-	n ≤ 1800 min ⁻¹	
19	03786000	-	-	-	-	1		
20	03786200	-	-	-	-	1	n ≤ 1500 min ⁻¹	
21	03786100	-	-	-	-	1	s. Taf. / Tabl. 04, Pos. 37	

M 07

Zylinderkopf
Cylinder head
Culasse
Culata
Testa

Tafel Nr.
Tabl. No.
Tavola N.

08

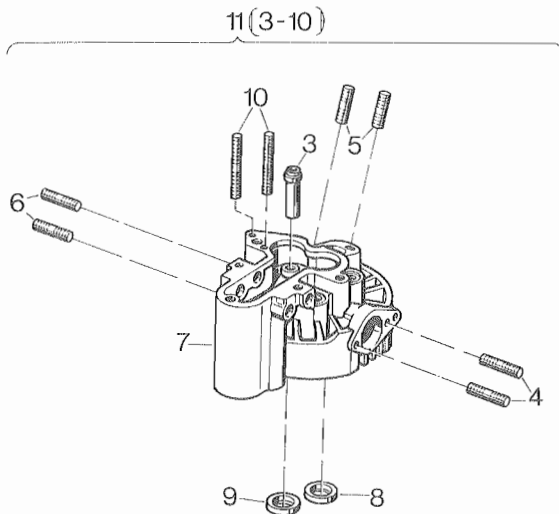
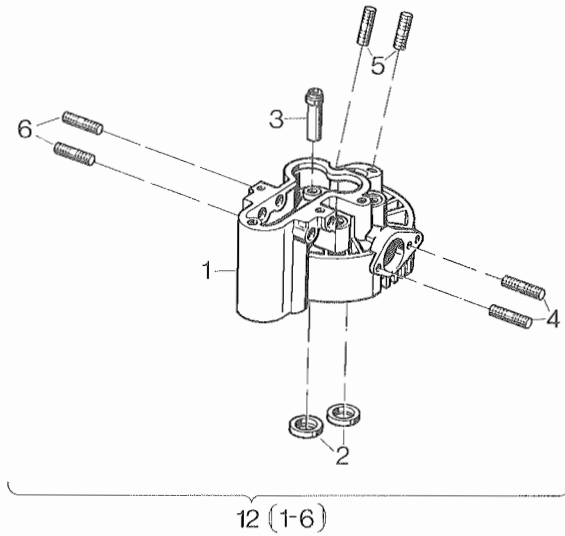

Fig.- No.	HATZ Ident-No.	Stück Qty.					P / W d / D	Bemerkungen Notes
		E 71	E 75	E 79	E780	E786		
1	-----	-	-	-	-	-		
2	-----	-	-	-	-	-		
3	03172310	2	2	2	2	-		
3	03203400	-	-	-	-	2		
4	50037300	2	2	-	-	-	M 8 x 18 DIN 835-10.9	
4	50285100	-	-	2	2	-	M 8 x 25 DIN 835-10.9	
4	50040300	-	-	-	-	2	M 10 x 22 DIN 939-5.6	
5	50038300	2	2	2	2	-	M 8 x 30 DIN 835-5.8	
5	50038500	-	-	-	-	2	M 8 x 40 DIN 835-5.8	
6	50037800	2	2	2	2	-	M 8 x 22 DIN 835-10.9	
6	50040300	-	-	-	-	2	M 10 x 22 DIN 939-5.6	
7	-----	-	-	-	-	-		
8	-----	-	-	-	-	-		
9	-----	-	-	-	-	-		
10	50036900	-	-	2	2	2	M 6 x 30 DIN 835-5.8	
11	00302211	-	-	1	-	-		
11	00300511	-	-	-	1	-		
11	01200801	-	-	-	-	1		
12	00302010	1	-	-	-	-		
12	00301810	-	1	-	-	-		

M 07

Zylinderkopf
Cylinder head
Culasse
Culata
Testa

Tafel Nr.
Tabl. No.
Tavola N.

09

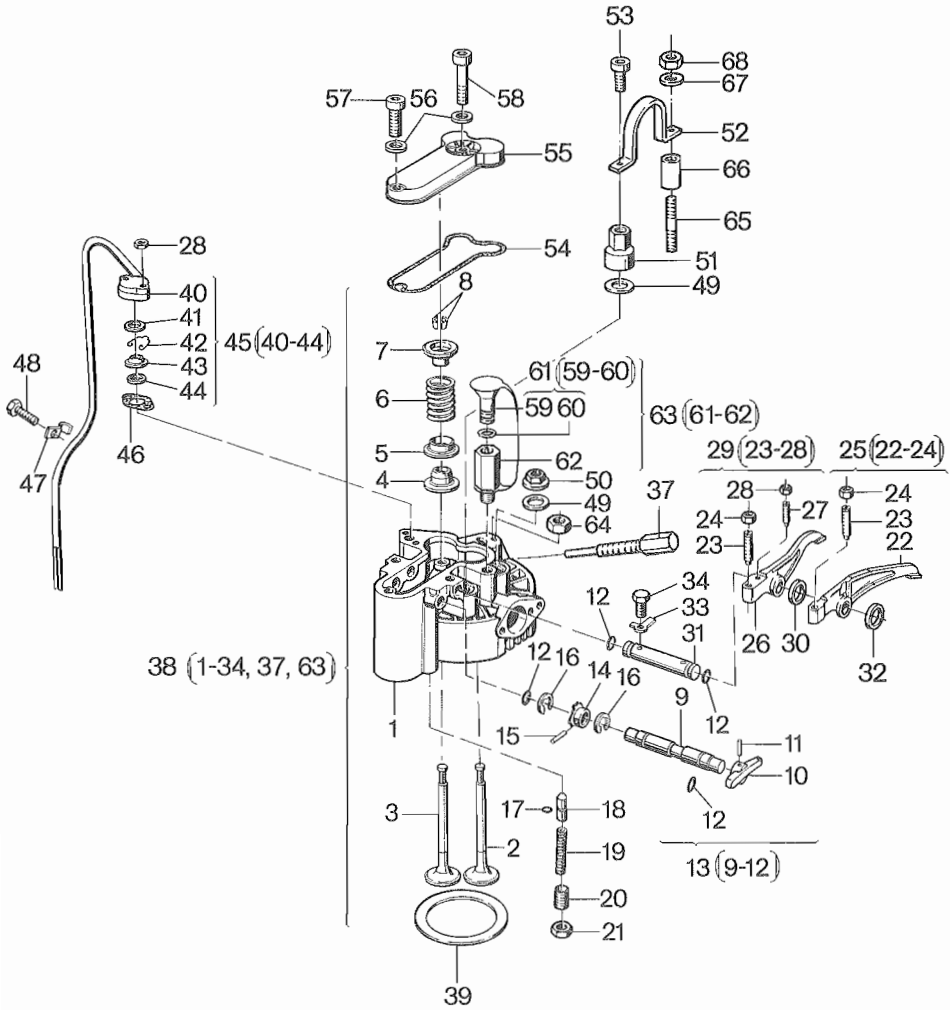

Fig.- No.	HATZ Ident-No.	Stück Qty.					P / W d / D	Bemerkungen Notes
		E 71	E 75	E 79	E780	E786		
1	00302010	1	-	-	-	-		
1	00301810	-	1	-	-	-		
1	00302211	-	-	1	-	-		
1	00300511	-	-	-	1	-		
1	01200801	-	-	-	-	1		
2	03124310	1	1	1	1	-		
2	03765900	-	-	-	-	1		
3	03124310	1	1	1	1	-		
3	03019910	-	-	-	-	1		
4	03172400	2	2	2	2	-		
4	03203200	-	-	-	-	2		
5	03173000	2	2	2	2	-		
5	03203300	-	-	-	-	2		
6	03172000	2	2	2	2	-		
6	03158701	-	-	-	-	2		
7	03004010	2	2	2	2	-		
7	03018510	-	-	-	-	2		
8	03171910	2	2	2	2	-		
8	03620900	-	-	-	-	2		
9	-----	-	-	-	-	-		
10	03173401	1	1	1	1	1		
11	50034600	1	1	1	1	1	d1	4 x 18 DIN 1481
12	40022300	4	4	4	4	4		
13	00340800	1	1	1	1	1		
14	03000801	1	1	1	1	1		
15	50034100	1	1	1	1	1		3 x 16 DIN 1481
16	40050200	2	2	2	2	2		
17	50154200	1	1	1	1	1	d1	
18	03010300	1	1	1	1	1		
19	03172801	1	1	1	1	1		
20	50005000	1	1	1	1	-		AM 10 x 25 DIN 913-45H
20	50005200	-	-	-	-	1		AM 10 x 35 DIN 913-45H
21	50023500	1	1	1	1	1		M 10 DIN 934-8

M 07

Zylinderkopf
Cylinder head
Culasse
Culata
Testa

Tafel Nr.
Tabl. No.
Tavola N.

09

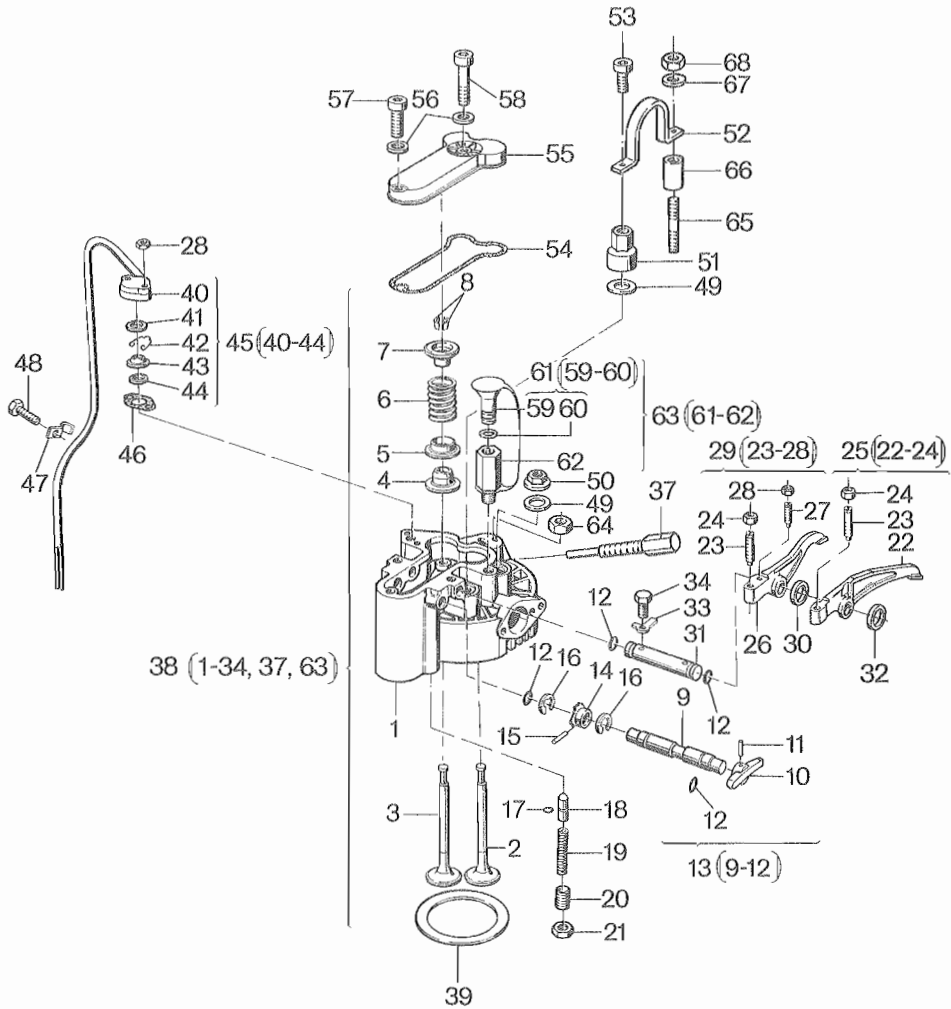

Fig.- No.	HATZ Ident-No.	Stück Qty.					P / W d / D	Bemerkungen Notes
		E 71	E 75	E 79	E780	E786		
22	-----	-	-	-	-	-		
23	03003700	2	2	2	2	2		
24	03173100	2	2	2	2	2	W2	
25	00340503	1	1	1	1	1		
26	-----	-	-	-	-	-		
27	03022001	1	1	1	1	1		
28	50144400	-	-	1	1	1	P2	M 6 DIN 934-8 A3C
29	00340604	1	1	1	1	1		
30	03034401	-	-	-	-	0..1		4,0 mm
30	03405300	-	-	-	-	0..1		4,1 mm
30	03400700	-	-	-	-	0..1		4,2 mm
30	03400800	-	-	-	-	0..1		4,3 mm
31	03172100	1	1	1	1	1		
32	03169400	0..1	0..1	0..1	0..1	0..1		0,10 mm
32	03169600	0..1	0..1	0..1	0..1	0..1		0,20 mm
32	03169700	0..1	0..1	0..1	0..1	0..1		0,30 mm
32	03169800	0..1	0..1	0..1	0..1	0..1		0,50 mm
33	50018700	2	2	2	2	2		6,4 DIN 463-St
34	50025500	2	2	2	2	-		M 6 x 12 DIN 933-8.8
34	50025700	-	-	-	-	2		M 6 x 16 DIN 933-8.8
37	03011500	1	1	1	1	-		
38	00412901	1	-	-	-	-		
38	00412503	-	1	-	-	-		
38	00413003	-	-	1	-	-		
38	00413101	-	-	-	1	-		
38	00997302	-	-	-	-	1		
39	03172200	0..1	0..1	-	-	-		0,40 mm
39	03173500	0..1	0..1	-	-	-	d1	0,50 mm
39	03173600	0..1	0..1	-	-	-		0,60 mm
39	03173700	0..1	0..1	-	-	-	d1	0,70 mm
39	03173800	0..1	0..1	-	-	-		0,80 mm
39	03173900	0..1	0..1	-	-	-		0,90 mm
39	03174000	0..1	0..1	-	-	-		1,00 mm

M 07

Zylinderkopf
Cylinder head
Culasse
Culata
Testa

Tafel Nr.
Tabl. No.
Tavola N.

09

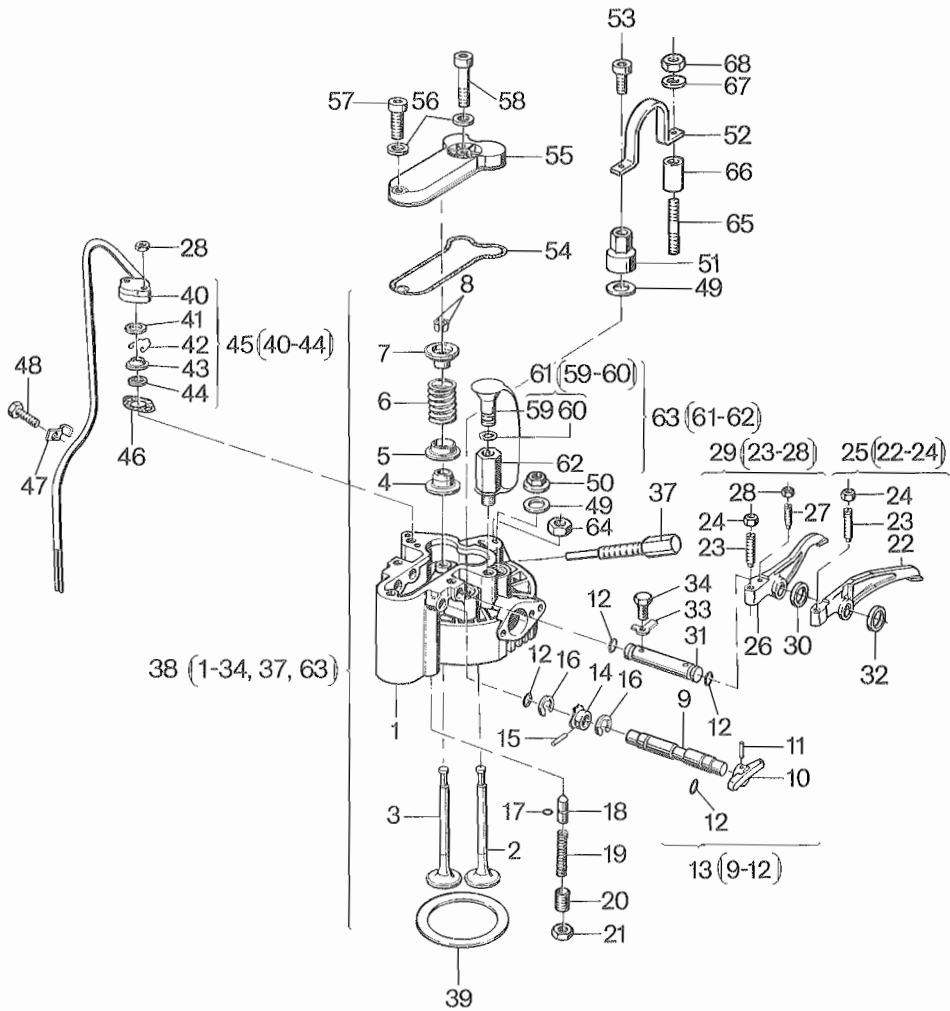

Fig.- No.	HATZ Ident-No.	Stück Qty.					P / W d / D	Bemerkungen Notes
		E 71	E 75	E 79	E780	E786		
39	03197300	-	-	0..1	0..1	-		0,40 mm
39	03197400	-	-	0..1	0..1	-	d1	0,50 mm
39	03197500	-	-	0..1	0..1	-		0,60 mm
39	03197600	-	-	0..1	0..1	-	d1	0,70 mm
39	03197700	-	-	0..1	0..1	-		0,80 mm
39	03197800	-	-	0..1	0..1	-	d1	0,90 mm
39	03197900	-	-	0..1	0..1	-		1,00 mm
39	03203500	-	-	-	-	0..1		0,40 mm
39	03203600	-	-	-	-	0..1		0,50 mm
39	03203700	-	-	-	-	0..1		0,60 mm
39	03203800	-	-	-	-	0..1	d1	0,70 mm
39	03203900	-	-	-	-	0..1		0,80 mm
39	03204000	-	-	-	-	0..1	d1	0,90 mm
39	03204100	-	-	-	-	0..1		1,00 mm
40	-----	-	-	-	-	-		
41	03444300	-	-	1	1	1		
42	03172700	-	-	1	1	1		
43	03172500	-	-	1	1	1		
44	03172600	-	-	1	1	1		
45	00356301	-	-	1	-	-		
45	00357601	-	-	-	1	-		
45	00360001	-	-	-	-	1		
46	03172901	-	-	1	1	1	d1	
47	03197201	-	-	1	-	-		
47	03016600	-	-	-	1	1		
48	50026700	-	-	1	1	1		M 8 x 16 DIN 933-8.8
49	03171700	4	4	4	4	4	P4	
50	03171800	2	2	2	2	-	P2	
50	03183000	-	-	-	-	2	P2	
51	03458000	2	2	2	2	-	P2	
51	03187301	-	-	-	-	2	P2	
52	03756900	1	1	1	1	-		
52	03756800	-	-	-	-	1		

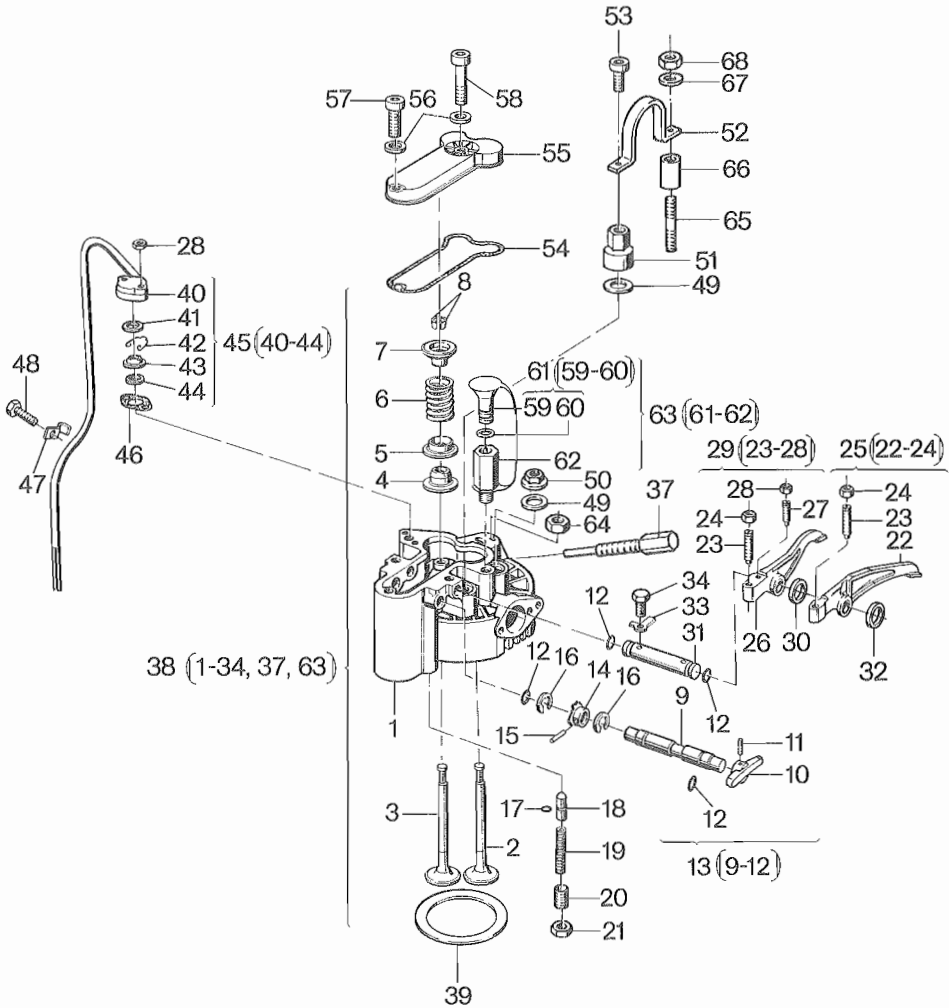

Fig.- No.	HATZ Ident-No.	Stück Qty.					P / W d / D	Bemerkungen Notes	
		E 71	E 75	E 79	E780	E786			
53	50051400	2	2	2	2	-		M 8 x 12	DIN 912-8.8
54	03174100	1	1	1	1	-	W3, d1		
54	03204200	-	-	-	-	1	W3, d1		
55	03174200	1	1	1	1	-			
55	03018300	-	-	-	-	1			
56	50162900	2	2	2	2	2	W6, d2	A 8 x 14	DIN 7603-Cu
57	50052200	1	1	1	1	1		M 8 x 30	DIN 912-8.8
58	50052900	1	1	1	1	-		M 8 x 60	DIN 912-8.8
58	50053000	-	-	-	-	1		M 8 x 70	DIN 912-8.8
59	-----	-	-	-	-	-			
60	40081700	2	2	2	2	2	d2	12 x 2	
61	00736300	1	1	1	1	1	P1		
62	-----	-	-	-	-	-			
63	00950700	1	1	1	1	1			
64	50022900	2	2	2	2	2		M 8	DIN 934-8
65	50130000	-	-	-	-	2		M 8 x 35	DIN 938-8.8
66	03641300	-	-	-	-	2			
65	50148100	-	-	-	-	2		8,4	DIN 125-St A3C
68	50022900	-	-	-	-	2		M 8	DIN 934-8

M 09

Stoßstangen
Pushrod
Tige de culbuteur
Varilla de balancin
Asta bilancieri

M 11

Steuerdeckel
Timing cover
Couvercle distribution
Tapa de mando
Coperchio distribuzione

Tafel Nr.
Tabl. No.
Tavola N.

10

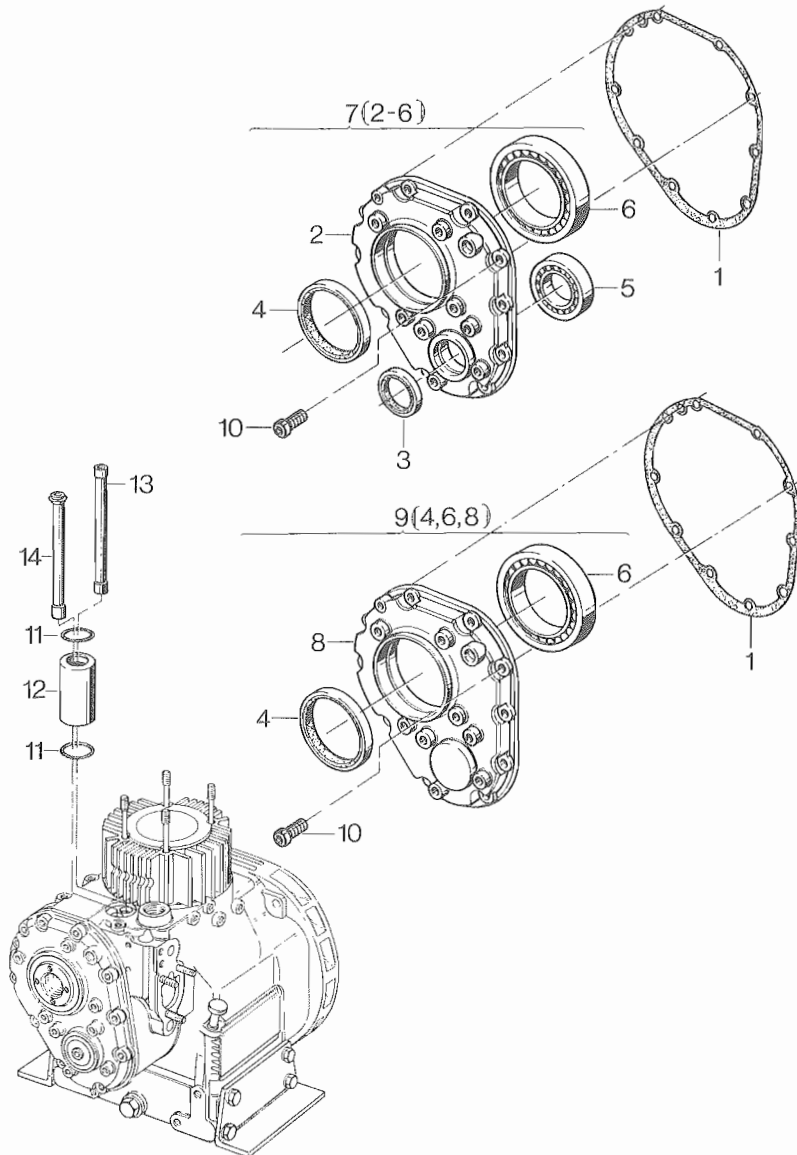

Fig.- No.	HATZ Ident-No.	Stück Qty.					P / W d / D	Bemerkungen Notes
		E 71	E 75	E 79	E780	E786		
1	03174500	1	1	1	1	1	D1	
2	-----	-	-	-	-	-		
3	40033800	1	1	1	1	1	D1	
4	40034700	1	1	1	1	1	D1	
5	50013000	1	1	1	1	1		
6	50015500	1	1	1	1	1		
7	00341101	1	1	1	1	1		E
8	-----	-	-	-	-	-		
9	00341301	1	1	1	1	1		ES
10	50052100	10	10	10	10	10		M 8 x 25 DIN 912-8.8
11	40023200	2	2	2	2	2	d2	
12	03174302	1	1	1	-	-		
12	03200301	-	-	-	1	-		
12	03204301	-	-	-	-	1		
13	00340901	1	1	1	-	-		
13	00357701	-	-	-	1	-		
13	00360101	-	-	-	-	1		
14	00341001	1	1	1	-	-		
14	00357801	-	-	-	1	-		
14	00360201	-	-	-	-	1		

M 14

Einspritzausrstung
Injection equipment
Equipment d'injection
Equipo de inyeccin
Equipaggiamento iniezione

Tafel Nr.
Tabl. No.
Tavola N.

11

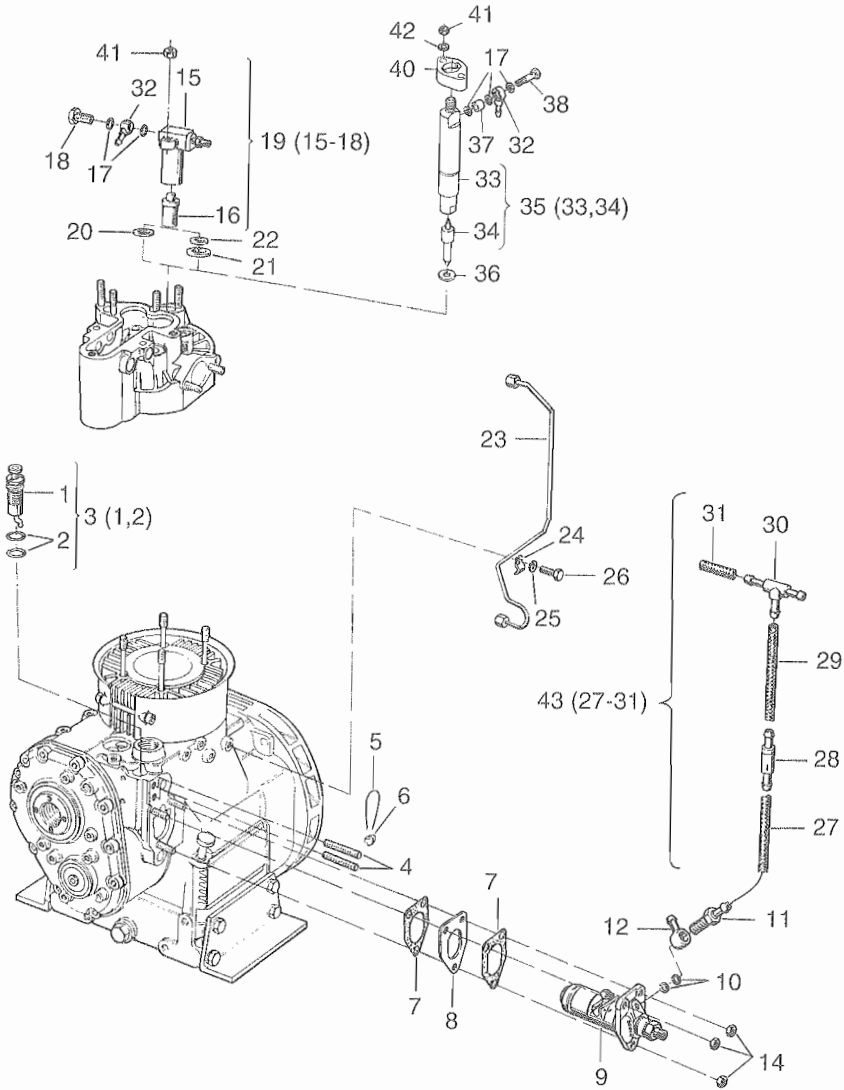

Fig.- No.	HATZ Ident-No.	Stück Qty.					P / W d / D	Bemerkungen Notes
		E 71	E 75	E 79	E780	E786		
1	-----	-	-	-	-	-		
2	40022900	2	2	2	2	2		
3	00341601	1	1	1	1	1		
4	03174600	2	2	2	2	2		
5	40021500	1	1	1	1	1		
6	40021400	1	1	1	1	1		
7	03168400	2	2	2	2	2	D2	
8	03168302	0..1	0..1	0..1	0..1	0..1		0,15 mm
8	03168501	0..1	0..1	0..1	0..1	0..1		0,20 mm
8	03168601	0..1	0..1	0..1	0..1	0..1		0,25 mm
8	03168701	0..1	0..1	0..1	0..1	0..1		0,30 mm
9	40005201	1	1	1	-	-		
9	40036901	-	-	-	1	-		
9	50257110	-	-	-	-	1		
10	50001100	2	2	2	2	2	D2	A 12 x 15,5 DIN 7603-Cu
11	03662300	1	1	1	1	1		
12	50015800	1	1	1	1	1		
14	50022900	3	3	3	3	3		M 8 DIN 934-8
15	-----	-	-	-	-	-		
16	40004600	1	1	1	1	-	P1	
17	50000900	2	2	2	2	3	d2	A 8 x 11,5 DIN 7603-Cu
18	50006100	1	1	1	1	-		A 2/3 DIN 7623
19	40006700	1	1	-	-	-		
19	40006800	-	-	1	1	-		
20	03160500	1	1	-	-	-	d1	
21	03012900	-	-	1	1	-		
22	40003000	-	-	1	1	-	P1	
23	00341701	1	1	1	-	-		
23	00357900	-	-	-	1	-		
23	00997400	-	-	-	-	1		
24	03174700	1	1	1	1	1		
25	50002800	1	1	1	1	1		8 DIN 128
26	50026700	1	1	1	1	1		M 8 x 16 DIN 933-8.8

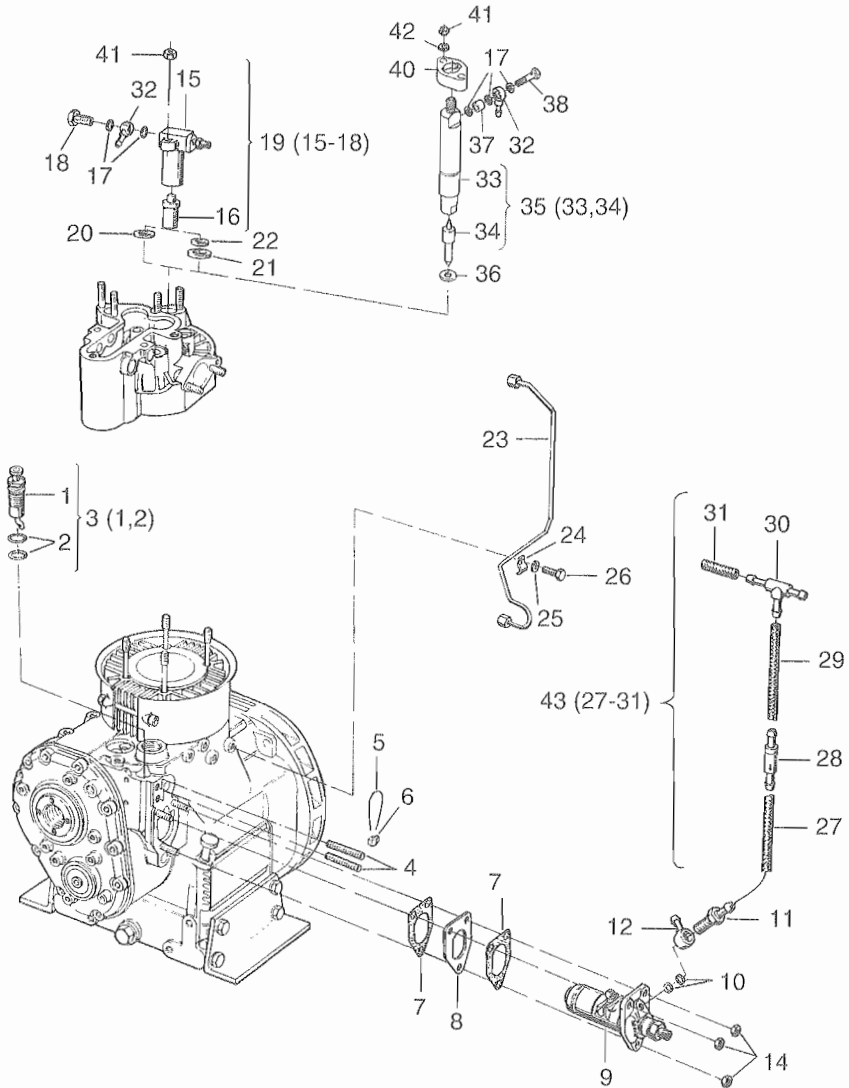

Fig.- No.	HATZ Ident-No.	Stück Qty.					P / W d / D	Bemerkungen Notes	
		E 71	E 75	E 79	E780	E786			
27	03663700	1	1	1	1	1		4,5 x 2,5 – 50 mm	
28	00805500	1	1	1	1	1	P1		
29	03806800	1	1	1	1	1		4,5 x 2,5 – 380 mm	
30	50157800	1	1	1	1	1			
31	03663700	1	1	1	1	1		4,5 x 2,5 – 50 mm	
32	50015700	1	1	1	1	1			
33	-----	-	-	-	-	-			
34	50257610	-	-	-	-	1	P1		
35	50257210	-	-	-	-	1			
36	40085001	-	-	-	-	1	d1		
37	03292900	-	-	-	-	1			
38	03292800	-	-	-	-	1			
39	-----	-	-	-	-	-			
40	03285000	-	-	-	-	1			
41	50022900	2	2	2	2	2	P2	M 8	DIN 934-8
42	50002800	-	-	-	-	2	P2	8	DIN 128
43	00835100	1	1	1	1	1			

M 17

Schwungräder
Flywheels
Volants
Volantes
Volano

M 26

Verschaltung
Cowling
Tole refroid.
Revestimiento
Carter ventilatore

Tafel Nr.
Tabl. No.
Tavola N.

12

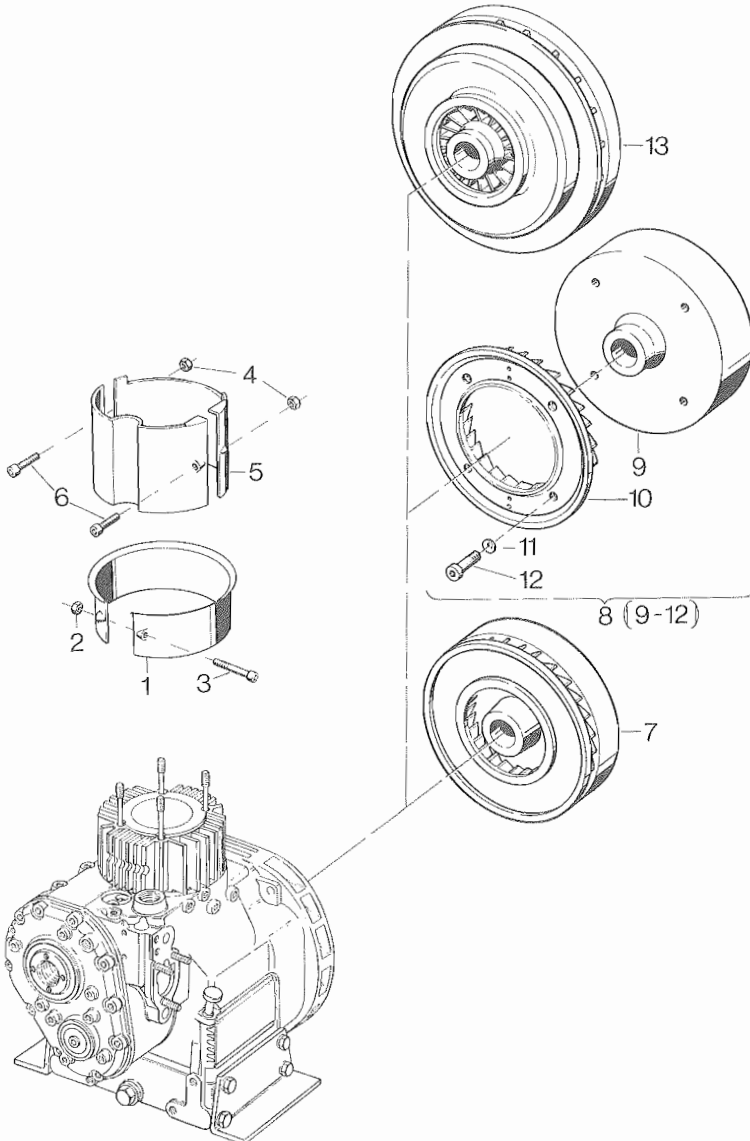

Fig.- No.	HATZ Ident-No.	Stück Qty.					P / W d / D	Bemerkungen Notes
		E 71	E 75	E 79	E780	E786		
1	03006800	1	1	-	-	-		
1	03013401	-	-	1	-	-		
1	03015801	-	-	-	1	-		
2	40028200	1	1	1	1	-	M 5	
3	50049800	1	1	1	1	-	AM 5 x 70 DIN 84-8.8	
4	40028200	-	-	-	-	2	M 5 SSN 440-8 Cu	
5	01201700	-	-	-	-	1		
6	50049600	-	-	-	-	2	AM 5 x 60 DIN 84-4.8	
7	03009403	1	1	-	-	-		
8	00908500	-	-	1	-	-		
9	-----	-	-	-	-	-		
10	03113000	1	1	1	-	-		
11	40027800	4	4	4	-	-		
12	40035700	4	4	4	-	-	M 8 x 35 DIN 6912-10.9	
13	03017010	-	-	-	1	-		
13	03769101	-	-	-	-	1		

Kraftstoffbehälter

Fuel tank

A 01

Reservoir à carburant

Depósito combustible

Serbatoio e circuito combustibile

Tafel Nr.

Tabl. No.

Tavola N.

13

53(51,52)

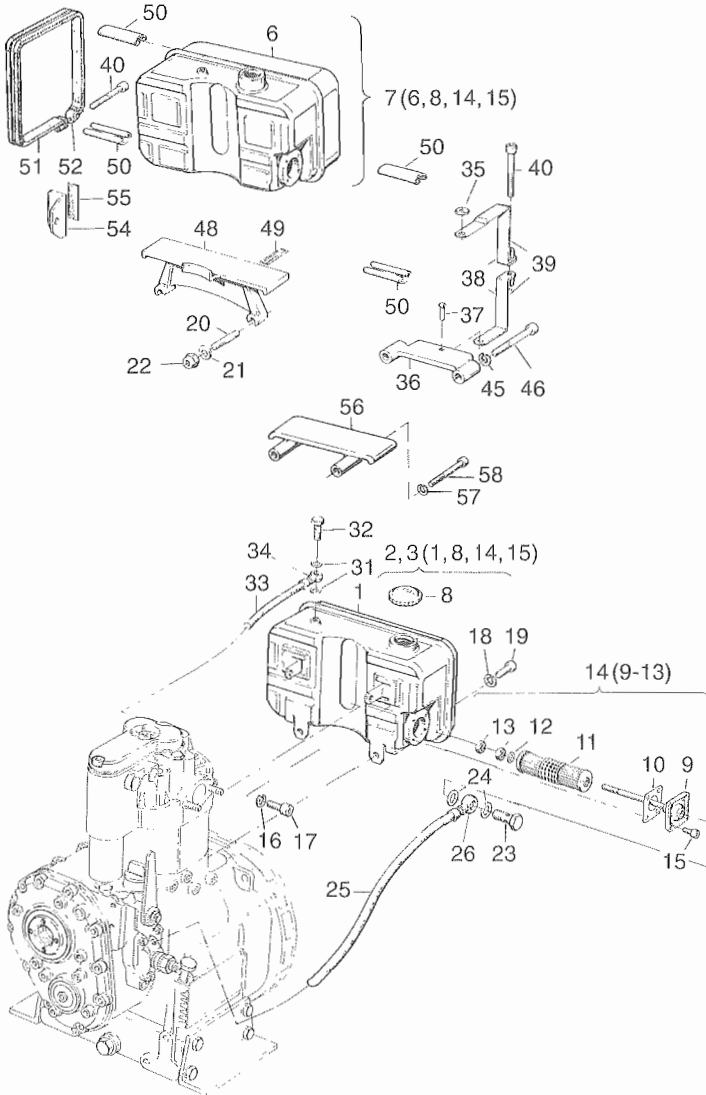

Fig.- No.	HATZ Ident-No.	Stück Qty.					P / W d / D	Bemerkungen Notes	
		E 71	E 75	E 79	E780	E786			
1	-----	-	-	-	-	-			
2	00412600	1	1	1	-	-		5 Ltr.	
3	00412700	1	1	1	-	-		9 Ltr.	
4	-----	-	-	-	-	-			
5	-----	-	-	-	-	-			
6	-----	-	-	-	-	-			
7	00413200	1	1	1	1	1		9 Ltr.	
8	40032701	1	1	1	1	1	P1		
9	-----	-	-	-	-	-			
10	03150202	1	1	1	1	1	W2,D1		
11	40043800	1	1	1	1	1	W2		
12	03150600	1	1	1	1	1	W1		
13	50023200	2	2	2	2	2	W2	BM 8	DIN 439-5 A3C
14	00329102	1	1	1	1	1			
15	50062700	4	4	4	4	4	W4	M 6 x 10	DIN 912-8.8
16	50208500	2	2	2	2	-		8	DIN 128-A3C
16	50135600	-	-	-	-	2		10	DIN 128-A3C
17	50165400	2	2	2	-	-		M 8 x 16	DIN 912-8.8 A3C
17	50051900	-	-	-	2	-		M 8 x 20	DIN 912-8.8
17	50053800	-	-	-	-	2		M 10 x 25	DIN 912-8.8
18	50135600	2	2	2	-	-		10	DIN 128-A3C
19	50173200	2	2	2	-	-		M 10 x 20	DIN 912-8.8 A3C
20	50180300	-	-	-	2	2		M 10 x 35	DIN 938-8.8 A3C
21	50145900	2	2	2	2	2		B 10,5	DIN 125-St A3C
22	50180200	-	-	-	2	2		M10	SSN001-8Zn
23	50006400	1	1	1	1	1		10-3	DIN 7643
24	50001200	2	2	2	2	2	W4,D2	A 14 x 18	DIN 7603-Cu
25	03693400	1	1	1	1	1		7,00 x 2,5 – 360 mm	
26	50015900	1	1	1	1	1		NW 8/6	
31	50000900	2	2	2	2	2		A 8 x 11,5	DIN 7603-Cu
32	50006100	1	1	1	1	1		4-5-3	DIN 7643
33	03663700	1	1	1	1	1		4,5 x 2,5 – 50 mm	
34	50015700	1	1	1	1	1		NW 3	

Kraftstoffbehälter
 Fuel tank
A 01 Reservoir à carburant
 Depósito combustible
 Serbatoio e circuito combustibile

Tafel Nr.
 Tabl. No.
 Tavola N.

13

53 (51, 52)

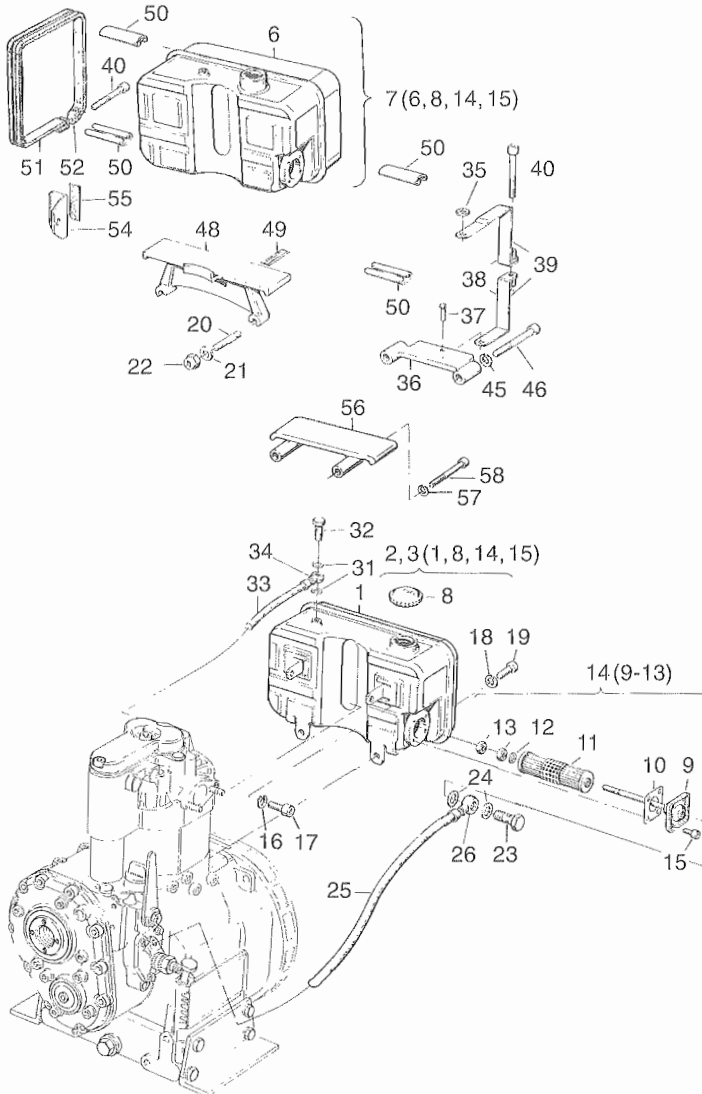

Fig.- No.	HATZ Ident-No.	Stück Qty.					P / W d / D	Bemerkungen Notes
		E 71	E 75	E 79	E780	E786		
35	50148000	1	1	1	-	-	M 8	DIN 934-8 A3C
36	03006310	1	1	1	-	-		
37	50165500	1	1	1	-	-	M 6 x 12	DIN 933-8.8 A3C
38	00778300	1	1	1	-	-	5 Ltr.	
39	00778201	1	1	1	-	-	9 Ltr.	
40	03537700	2	2	2	2	2		
43	-----	-	-	-	-	-		
44	-----	-	-	-	-	-		
45	50002900	2	2	2	-	-	10	DIN 128
46	50055200	2	2	2	-	-	M 10 x 60	DIN 912-8.8
47	-----	-	-	-	-	-		
48	03015701	-	-	-	1			
48	03019001	-	-	-	-	1		
49	03506300	2	2	2	2	-		
49	03506400	-	-	-	-	2		
50	03188600	4	4	4	4	4		
51	00562700	2	2	2	-	-		
51	03200500	-	-	-	2	2		
52	00778500	-	-	-	2	2		
53	00562700	-	-	-	2	2		
54	03014800	2	2	2	2	-		
54	03018200	-	-	-	-	2		
55	03506200	2	2	2	2	2		
56	03853300	1	1	1	-	-		
57	50145900	2	2	2	-	-	10,5	DIN 125-St A3C
58	50084000	2	2	2	-	-	M 10 x 90	DIN 912-8.8

A 01

Kraftstofffilter
Fuel filter
Filtre à carburant
Depósito combustible
Filtro de combustible

Tafel Nr.
Tabl. No.
Tavola N.

14

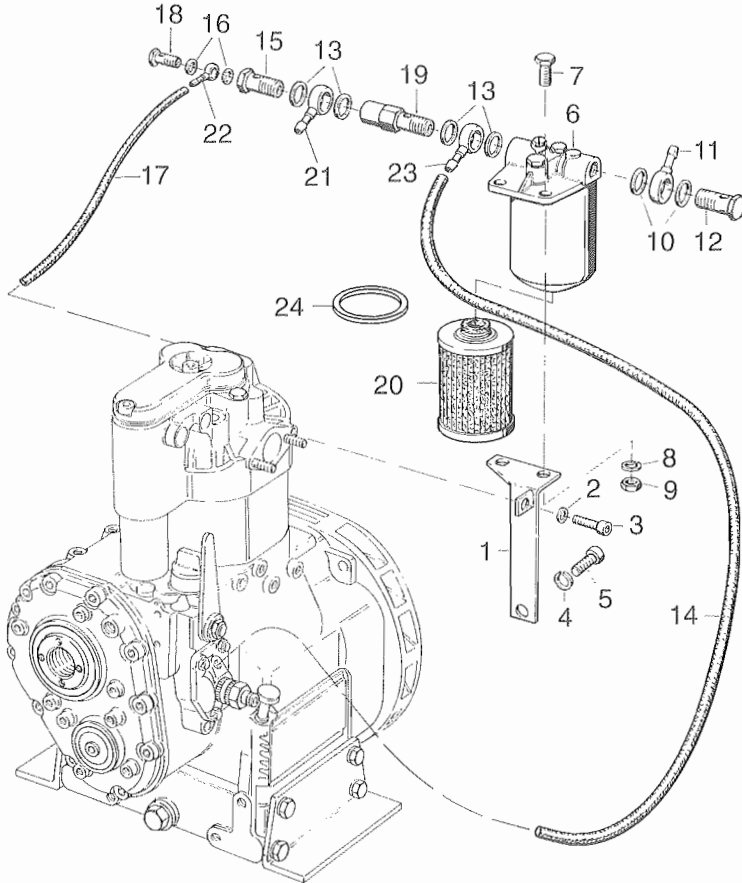

Fig.- No.	HATZ Ident-No.	Stück Qty.					P / W d / D	Bemerkungen Notes
		E 71	E 75	E 79	E780	E786		
1	00621100	1	1	1	-	-		
1	00420200	-	-	-	1	-		
1	00420300	-	-	-	-	1		
2	50002800	1	1	1	1	-	8 DIN 128	
2	50002900	-	-	-	-	1	10 DIN 128	
3	50051900	1	1	1	1	1	M 8 x 20 DIN 912-8.8	
3	50053800	-	-	-	-	1	M 10 x 25 DIN 912-8.8	
4	50002900	1	1	1	1	1	10 DIN 128	
5	50053600	-	-	-	-	1	M 10 x 20 DIN 912-8.8	
5	50029200	1	1	1	1	1	M 10 x 25 DIN 933-8.8	
6	40067400	1	1	1	1	1		
7	50029300	2	2	2	2	2	M 10 x 30 DIN 933-8.8	
8	50002900	2	2	2	2	2	10 DIN 128	
9	50023500	2	2	2	2	2	M 10 DIN 934-8	
10	50001200	2	2	2	2	2	D2 A 14 x 18 DIN 7603-Cu	
11	50015900	1	1	1	1	1	NW 8/6	
12	50006400	1	1	1	1	1	10/3 DIN 7643	
13	50001200	4	4	4	4	4	A 14 x 18 DIN 7603-Cu	
14	03673200	1	1	1	-	-	7,0 x 2,5 – 470 mm	
14	03674200	-	-	-	1	1	7,0 x 2,5 – 550 mm	
15	03280700	1	1	1	1	1	M 14 x 1,5	
16	50000900	2	2	2	2	2	A 8 x 11,5 DIN 7603-Cu	
17	03663700	1	1	1	-	-	4,5 x 2,5 – 50 mm	
17	03673100	-	-	-	1	1	4,5 x 2,5 – 65 mm	
18	50006100	1	1	1	1	1	4-5-3 DIN 7643	
19	03497700	1	1	1	1	1		
20	40007300	1	1	1	1	1		
21	50151700	1	1	1	1	1	NW 8/4	
22	50015700	1	1	1	1	1	NW 3	
23	50015900	1	1	1	1	1	NW 8/6	
24	49036500	1	1	1	1	1		

A 02

Luftfilter
Air filter
Filtre à air
Filtro de aire
Filtro aria

Tafel Nr.
Tabl. No.
Tavola N.

15

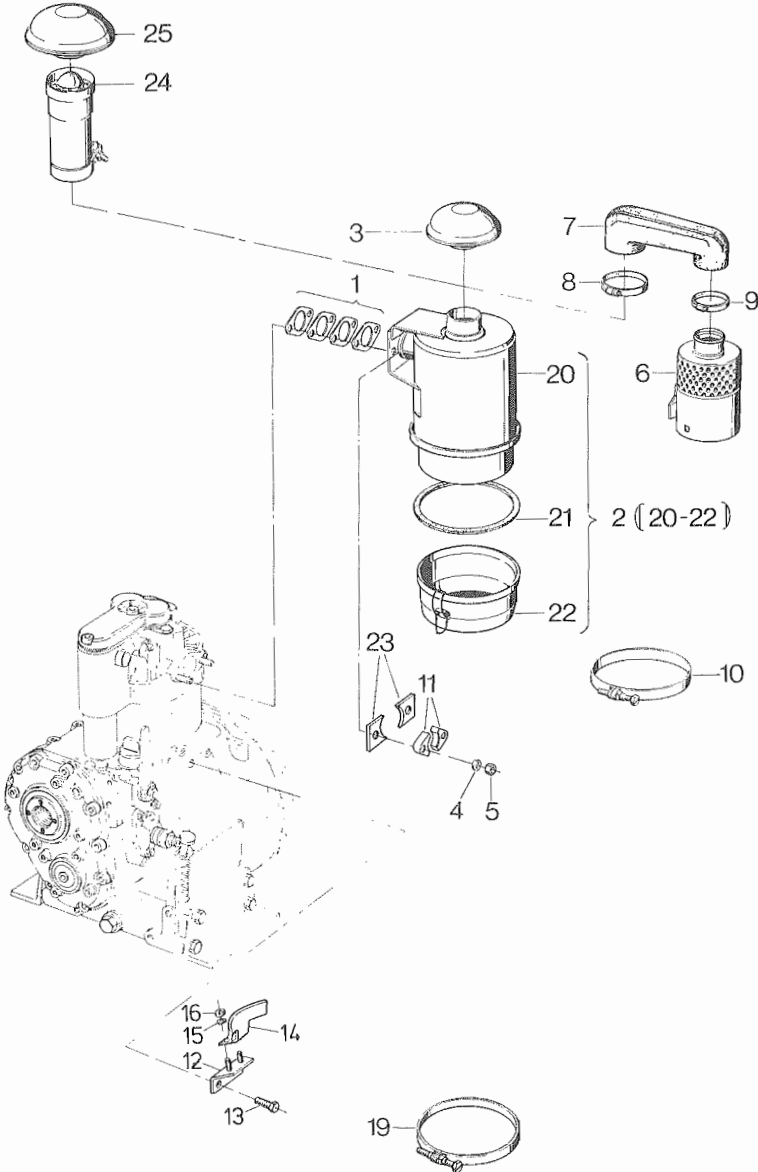

Fig.- No.	HATZ Ident-No.	Stück Qty.					P / W d / D	Bemerkungen Notes	
		E 71	E 75	E 79	E780	E786			
1	01154000	1	1	1	1	-	W1,d1		
1	01158700	-	-	-	-	1	W1,d1		
2	40102900	1	1	-	-	-			
2	01410801	-	-	1	-	-			
2	40103000	-	-	-	1	-			
2	01078501	-	-	-	-	1			
3	40099500	1	1	-	-	-	P1		
3	40040400	-	-	1	1	-	P1		
3	40036700	-	-	-	-	1	P1	62 mm	
4	50208500	2	2	-	-	-	8	DIN 128-A3C	
4	50285200	-	-	2	2	-	VSK 8	A3C	
4	50135600	-	-	-	-	2	10	DIN 128-A3C	
5	40081600	2	2	-	-	-	M 8	Ms	
5	40028400	-	-	2	2	-		DIN980-8 C3A	
5	50145800	-	-	-	-	2	M 10	DIN 934-8 A3C	
6	40099600	1	1	-	-	-			
6	40103100	-	-	-	1	-			
7	03324500	1	1	-	-	-			
7	03531900	-	-	-	1	-			
8	40053500	1	1	-	-	-			
8	40095500	-	-	-	1	-			
9	40071500	1	1	-	1	-			
10	40101000	1	1	-	-	-			
10	40029600	-	-	-	1	-			
11	03903700	-	-	2	2	-			
12	01164100	-	-	-	-	1			
13	50026700	-	-	-	-	2	M 8 x 16	DIN 933-8.8	
14	03943800	-	-	-	-	1			
15	50114300	-	-	-	-	2	6,4	DIN 7349 Zn	
16	50026700	-	-	-	-	2	M 6	DIN 934-8 A3C	
17	-----	-	-	-	-	-			
19	40029600	-	-	-	-	1			

Luftfilter
Air filter
Filtre à air
Filtro de aire
Filtro aria

A 02

Tafel Nr.
Tabl. No.
Tavola N.

15

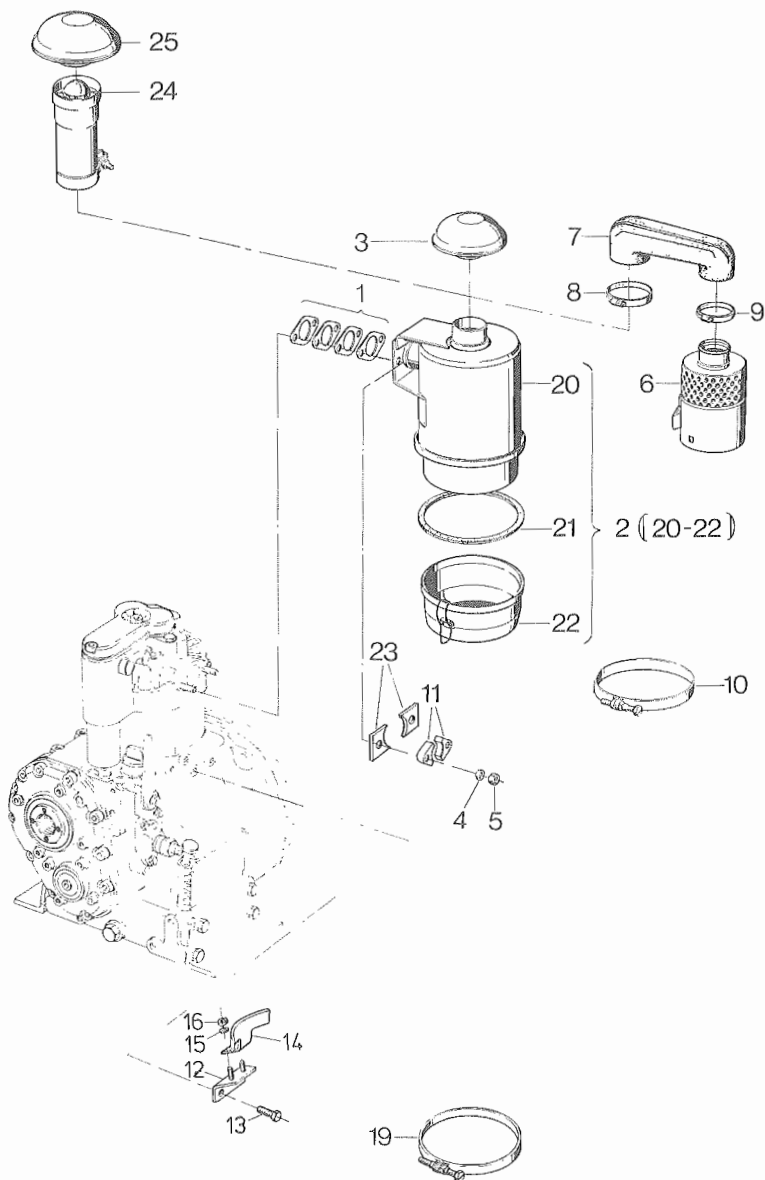

Fig.- No.	HATZ Ident-No.	Stück Qty.					P / W d / D	Bemerkungen Notes
		E 71	E 75	E 79	E780	E786		
20	-----	-	-	-	-	-		
21	49037500	1	1	-	-	-	P1	
21	49061900	-	-	1	-	-	P1	
21	49038000	-	-	-	1	1	P1	
22	49038100	1	1	-	-	-		
22	49061800	-	-	1	-	-		
22	49037900	-	-	-	1	-		
22	49056600	-	-	-	-	1		
23	03945400	-	-	-	-	2		
24	01411000	-	-	1	-	-		
24	01119401	-	-	-	-	1		
25	40036600	-	-	1	-	1		

Abgasschalldämpfer
 Exhaust silencer
 Silencieux
 Silenciador
 Marmitta

Tafel Nr.
 Tabl. No.
 Tavola N.

A 03

16

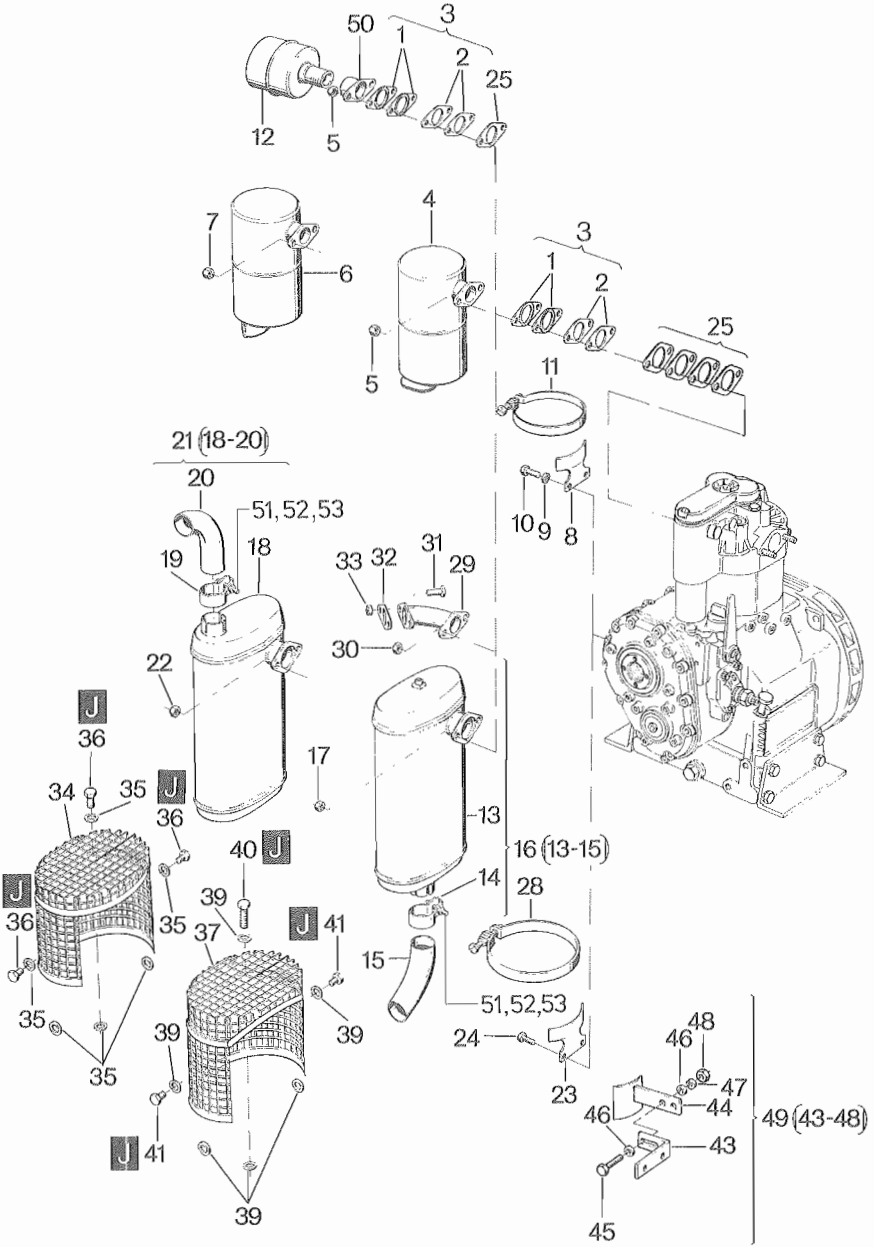

Fig.- No.	HATZ Ident-No.	Stück Qty.	E 71	E 75	E 79	E780	E786	P / W d / D	Bemerkungen Notes
			E 71	E 75	E 79	E780	E786		
1	-----	-	-	-	-	-	-		
2	-----	-	-	-	-	-	-		
3	01153900	1	1	1	1	1	-	d1	
4	00859901	1	1	1	-	-	-		
5	50023000	2	2	2	2	-	-	M 8 Ms	DIN 934
5	50023700	-	-	-	-	2	-	M 10	DIN 934-Ms
6	00860001	1	1	1	-	-	-		
7	40081600	2	2	2	-	-	-	M 8 Ms	
8	03078300	1	1	1	-	-	-		
9	50002800	2	2	2	-	-	-	8	DIN 128
10	50026700	2	2	2	-	-	-	M 8 x 16	DIN 933-8.8
11	40029000	1	1	1	-	-	-		
12	00872200	1	1	1	1	1	1	R 1 1/4	
13	-----	-	-	-	-	-	-		
14	03727100	1	1	1	1	1	1		
15	03727200	1	1	1	1	-	-		
15	03740700	-	-	-	-	1	-		
16	00859300	1	1	1	1	-	-		
16	00857900	-	-	-	-	1	-		
17	40081600	2	2	2	2	-	-	M 8 Ms	
17	50023700	-	-	-	-	2	-	M 10	DIN 934 Ms
18	-----	-	-	-	-	-	-		
19	03727100	1	1	1	1	1	1		
20	03727200	1	1	1	1	-	-		
20	03740700	-	-	-	-	1	-		
21	00862200	1	1	1	1	-	-		
21	00857800	-	-	-	-	1	-		
22	40081600	2	2	2	2	-	-	M 8 Ms	
22	50023700	-	-	-	-	2	-	M 10	DIN 934 Ms
23	03005101	1	1	1	-	-	-		
23	03015600	-	-	-	1	-	-		
23	03066800	-	-	-	-	1	-		
24	50026700	2	2	2	2	2	2	M 8 x 16	DIN 933-8.8

Abgasschalldämpfer
 Exhaust silencer
 Silencieux
 Silenciador
 Marmitta

Tafel Nr.
 Tabl. No.
 Tavola N.

A 03

16

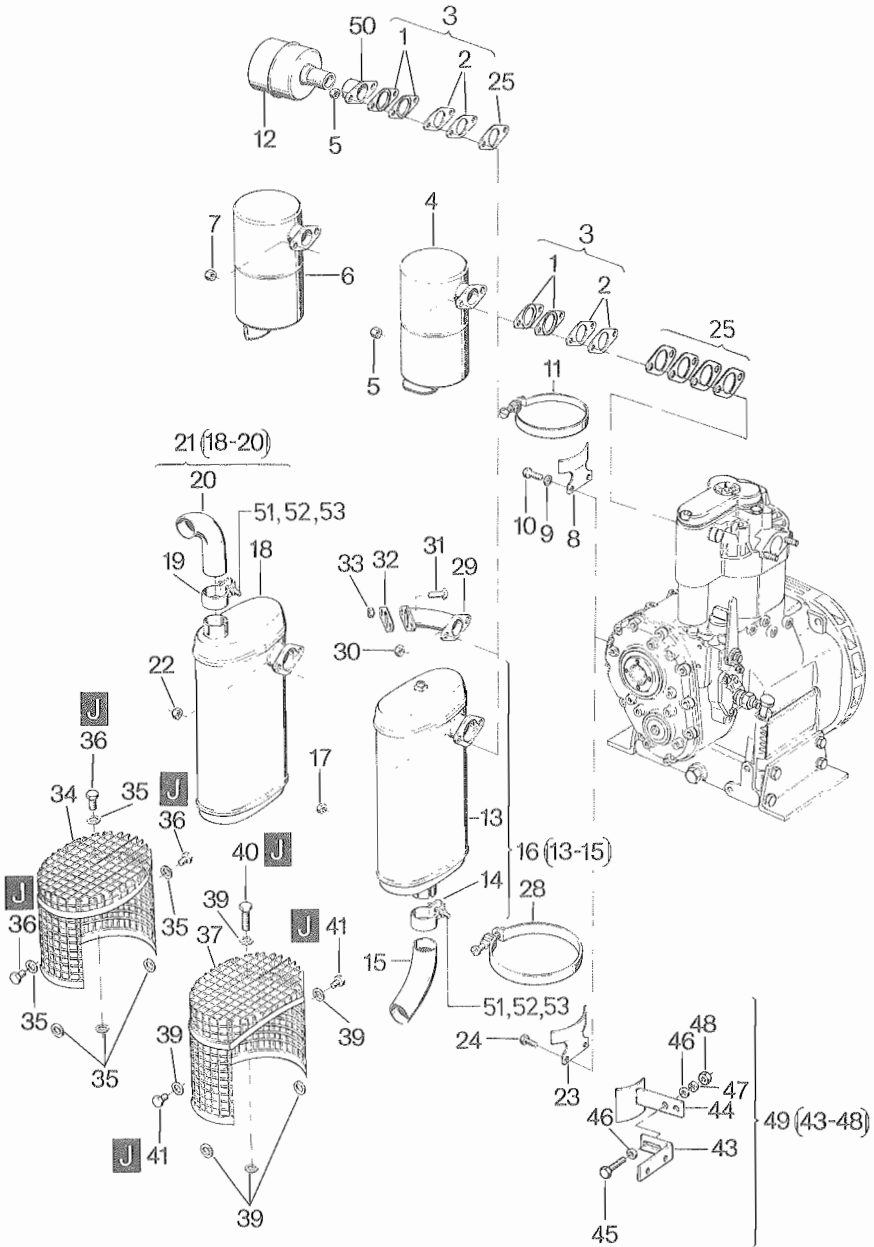

Fig.- No.	HATZ Ident-No.	Stück Qty.					P / W d / D	Bemerkungen Notes
		E 71	E 75	E 79	E780	E786		
25	01285800	-	-	-	-	1	d1	
28	40029400	1	1	1	1	-		
28	40029600	-	-	-	-	1		
29	00312500	1	1	1	1	-		
30	40081600	2	2	2	2	-	M 8 Ms	
31	50135400	2	2	2	2	-	M 8 x 20	DIN 933-8.8 A3C
32	01153900	1	1	1	1	-		
33	40081600	2	2	2	2	-	M 8 Ms	
34	00785300	1	1	1	1	-		
35	50016800	6	6	6	6	-	8,4	DIN 125 Ms
36	50173100	3	3	3	3	-	M 8 x 10	DIN 912-8.8 A3C
37	00785400	-	-	-	-	1		
39	50016800	-	-	-	-	6	8,4	DIN 125 Ms
40	50173100	-	-	-	-	1	M 8 x 10	DIN 912-8.8 A3C
41	50173100	-	-	-	-	2	M 8 x 10	DIN 912-8.8 A3C
42	-----	-	-	-	-	-		
43	-----	-	-	-	-	-		
44	-----	-	-	-	-	-		
45	50026800	2	2	2	-	-	M 8 x 20	DIN 933-8.8
46	50148100	4	4	4	-	-	8,4	DIN 125-St
47	50002800	2	2	2	-	-	8	DIN 128
48	50022900	2	2	2	-	-	8	DIN 934-8
49	00314410	1	1	1	-	-		
50	03828900	1	1	1	1	-		
50	03829100	-	-	-	-	1		
51	50028100	1	1	1	1	1	M 8 x 50	DIN 931-8.8
52	50128200	1	1	1	1	1	8	DIN 127
53	50022900	1	1	1	1	1	M 8	DIN 934-8

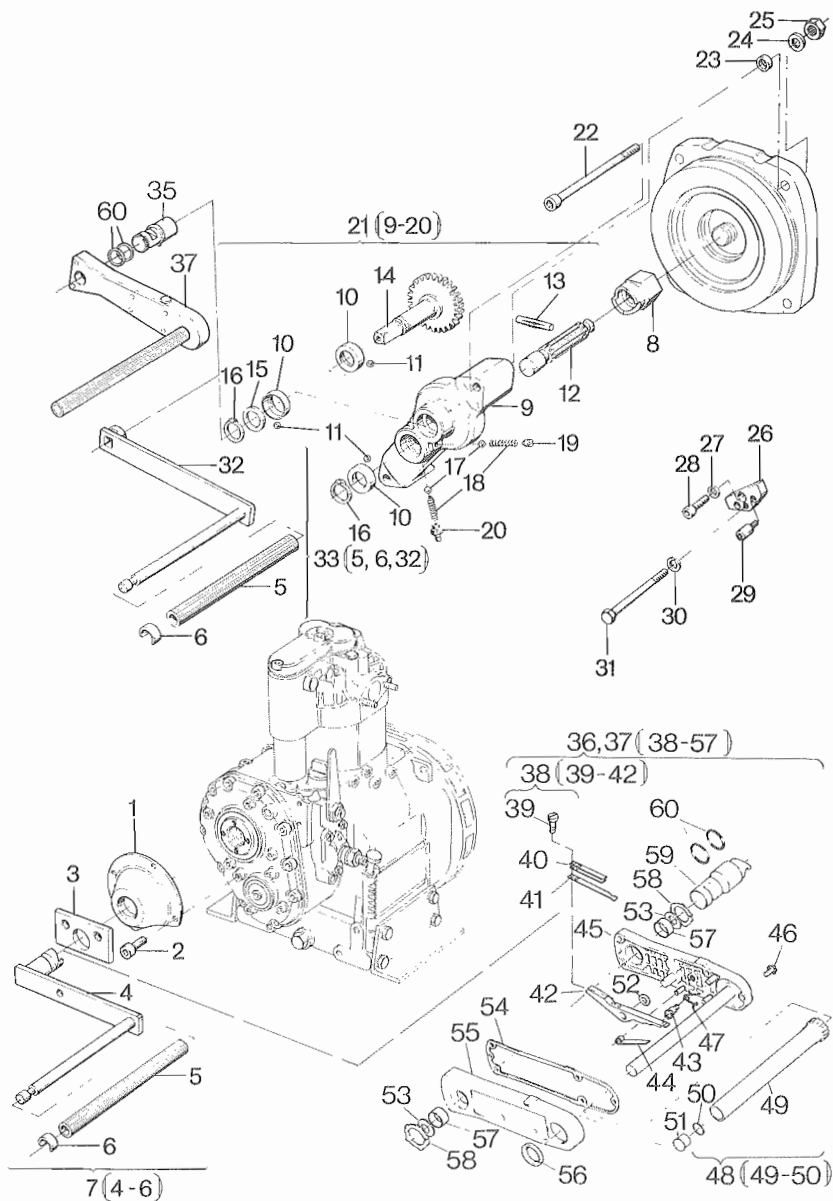

Fig.- No.	HATZ Ident-No.	Stück Qty.					P / W d / D	Bemerkungen Notes
		E 71	E 75	E 79	E780	E786		
1	03382700	1	1	1	1	1		
2	50165400	4	4	4	4	4	M 8 x 16 DIN 912-A3C	
3	03010700	1	1	1	1	1		
4	-----	-	-	-	-	-		
5	03522400	1	1	1	1	1		
6	03515400	1	1	1	1	1		
7	00301902	1	1	1	1	1	50 mm	
7	00303302	1	1	1	1	1	77 mm	
7	00303202	1	1	1	1	1	122 mm	
7	00301500	1	1	1	1	1	177 mm	
7	00303102	1	1	1	1	1	242 mm	
7	00863700	1	1	1	1	1	320 mm	
8	03007401	1	1	1	-	-		
8	03732400	-	-	-	1	-		
8	03066900	-	-	-	-	1		
9	-----	-	-	-	-	-		
10	03175301	3	3	3	3	3		
11	50009800	45	45	45	45	45		
12	03008500	1	1	1	1	1		
13	50009500	1	1	1	1	1	8 x 45 DIN 1475	
14	03011300	1	1	1	1	1		
15	03012401	1	1	1	1	1		
16	50020400	2	2	2	2	2	24 x 1,2 DIN 471	
17	50009800	2	2	2	2	2		
18	03159100	2	2	2	2	2		
19	03079400	1	1	1	1	1		
20	50007800	1	1	1	1	1	AM 8 x 1 DIN 71412	
21	00341903	1	1	-	-	-		
21	00335602	-	-	1	1	1		
22	50055900	2	2	-	-	-	M 10 x 120 DIN 912-8.8 A3C	
23	03175400	2	2	2	-	-		
24	50145900	2	2	2	-	-	10,5 DIN 125-St A3C	
25	50023500	2	2	2	-	-	M 10 DIN 934-8	
26	03012301	-	-	2	-	-		
26	03732300	-	-	-	2	-		

A 04

Andrehkurbel, Andrehvorrichtung schs.
Starting handle, starting device flywheel side
Manivelle, dispositif demarrage
Manivella, dispositivo de arranque
Manovella, dispositivo di avviamento

Tafel Nr.
Tabl. No.
Tavola N.

17

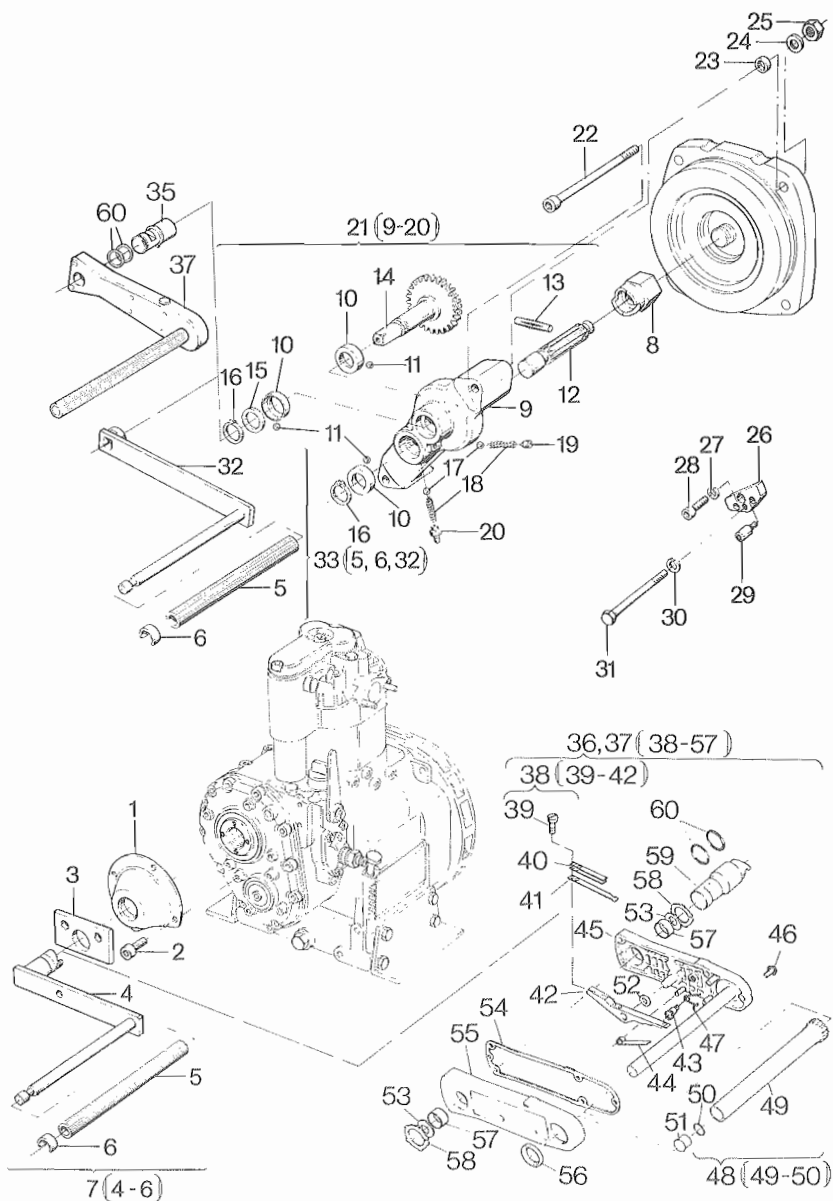

Fig.- No.	HATZ Ident-No.	Stück Qty.	P / W d / D	Bemerkungen Notes			
		E 71 E 75 E 79 E780 E786					
27	-----	-	-	-			
28	50041600	-	-	2	-	M 10 x 55 DIN 938-5.6	
28	50052600	-	-	-	4	M 8 x 45 DIN 912-8.8	
29	50083200	-	-	4	4	8 m 6 x 30 DIN 7-St 50 k	
30	50002900	-	-	4	2	2	10 DIN 128
31	50030400	-	-	2	2	2	M 10 x 90 DIN 931-8.8
32	-----	-	-	-	-	-	
33	00303002	1	1	1	1	1	
35	01018900	1	1	1	1	1	
36	01027805	1	1	1	1	1	„A“
37	01027905	1	1	1	1	1	„B“
38	01011404	1	1	1	1	1	
39	50316500	2	2	2	2	2	M 5 x 8 DIN 6912-8.8
40	03917100	2	2	2	2	2	
41	03812102	1	1	1	1	1	
42	-----	-	-	-	-	-	
43	03955600	1	1	1	1	1	
44	03954900	1	1	1	1	1	
45	-----	-	-	-	-	-	
46	50194400	5	5	5	5	5	M 6 x 25 A3C
47	03955900	1	1	1	1	1	„A“
47	03956000	1	1	1	1	1	„B“
48	01011310	1	1	1	1	1	
49	-----	-	-	-	-	-	
50	50169100	1	1	1	1	1	19 x 1,8
51	50199200	1	1	1	1	1	
52	50195800	1	1	1	1	1	10 x 16 x 0,5 DIN 988
53	03928600	2	2	2	2	2	30 x 38 x 0,15
54	03813000	1	1	1	1	1	
55	-----	-	-	-	-	-	
56	50194200	1	1	1	1	1	
57	50193400	2	2	2	2	2	
58	50194300	2	2	2	2	2	AK 30 x 1,5 K
59	01019500	1	1	1	1	1	50 mm
59	01019600	1	1	1	1	1	77 mm
59	01019700	1	1	1	1	1	122 mm
59	01020000	1	1	1	1	1	242 mm
59	01048700	1	1	1	1	1	320 mm
60	50258500	2	2	2	2	2	

Fig.- No.	HATZ Ident-No.	Stück Qty.					P / W d / D	Bemerkungen Notes
		E 71	E 75	E 79	E780	E786		
1	03809500	1	1	1	-	-		
1	03204410	-	-	-	1	1		
2	00311500	-	-	-	-	1		
3	50331400	-	-	-	2	2	M 12 x 35 DIN 835-8.8 A3C	
4	03020000	-	-	-	1	1		
5	40000500	-	-	-	1	1	12 V	
6	50063200	-	-	-	3	3	12 DIN 128 A3C	
7	50093600	-	-	-	1	1	M 12 DIN 934-8 A3C	
8	03684200	-	-	-	1	-		
9	50031800	-	-	-	2	-	M 12 x 70 DIN 931-8.8 A3C	
10	40026600	-	-	-	1	1		
11	40028600	4	4	4	-	-	VM 10 DIN 980-8 C3A	
12	50145900	4	4	4	-	-	10,5 DIN 125-St A3C	
13	03809201	-	-	1	-	-		
14	03014100	-	-	1	-	-		
15	03803901	1	1	1	-	-	SAE 6	
16	50145300	2	2	2	-	-	M 10 x 65 DIN 835-8.8 A3C	
17	03809000	1	1	1	-	-		
18	50193000	1	1	1	-	-	12 V - 0,8 kW	
19	50061700	2	2	2	-	-	A 10 DIN 137	
20	50023500	2	2	2	-	-	M 10 DIN 934-8	
21	40027000	4	4	-	-	-	M 10 x 65	
21	50055800	-	-	4	-	-	M 10 x 85 DIN 6912-8.8	
22	03848401	-	-	-	1	1	„U“	
23	03847502	1	1	1	1	1		
24	-----	-	-	-	-	-		
25	50002800	4	4	4	4	4	8 DIN 128	
26	50052100	4	4	4	4	4	M 8 x 25 DIN 912-8.8	
26	50052300	-	-	-	4	4	M 8 x 35 DIN 912-8.8 „U“	
27	03856210	1	1	1	1	1		
28	50061700	4	4	4	4	4	A 10 DIN 137	
29	50053500	4	4	4	4	4	M 10 x 16 DIN 6912-8.8	
30	-----	-	-	-	-	-		

Starter, Generator
 Starter, alternator
A 05 Demarreur, alternateur
 Arrancador, alternador
 Motorino avviamento, alternatore

Tafel Nr.
 Tabl. No.
 Tavola N.

18

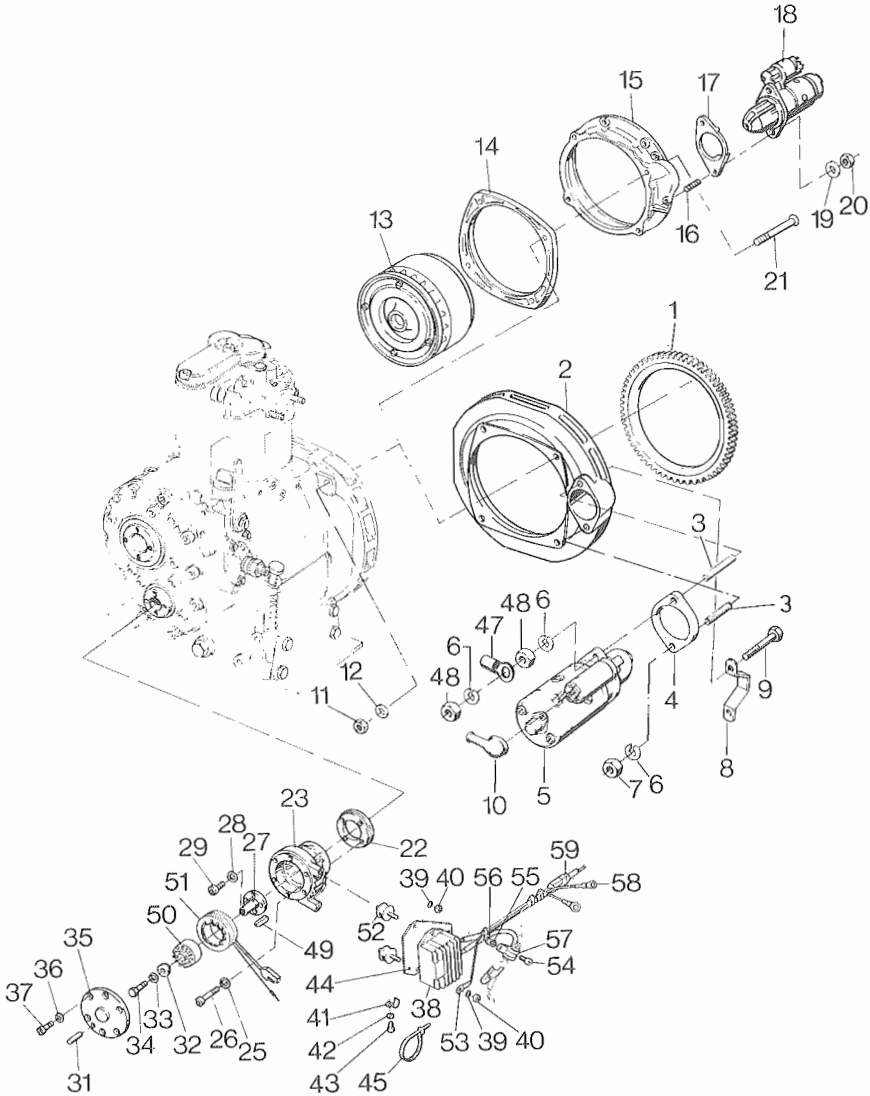

Fig.- No.	HATZ Ident-No.	Stück Qty.					P / W d / D	Bemerkungen Notes	
		E 71	E 75	E 79	E780	E786			
31	50012400	1	1	1	1	1		5 x 24	DIN 1472
32	50070600	1	1	1	1	1		10,5	DIN 7349 A3C
33	50245100	1	1	1	1	1		B 10 x 18	DIN 137
34	50054000	1	1	1	1	1		M 10 x 25	DIN 6912-8.8
35	03847601	1	1	1	1	1			
36	50002600	6	6	6	6	6		5	DIN 128 A3C
37	50269600	6	6	6	6	6		M 5 x 25	DIN 912-8.8
38	50269410	1	1	1	1	1		12 V	
39	50095100	2	2	2	2	2		A 8	DIN 137 A3C
40	50335300	2	2	2	2	2		M 8	SW 12 A3C
41	03801100	1	1	1	1	1			
42	50002700	1	1	1	1	1		6	DIN 128
43	50050300	1	1	1	1	1		M 6 x 8	DIN 912-8.8
44	03946300	1	1	1	1	1			
45	50167400	6	6	6	4	4			
46	-----	-	-	-	-	-			
47	50160400	-	-	-	1	1			
48	50063500	-	-	-	2	2		M 12	DIN 936-17H A3C
49	50010800	1	1	1	1	1		4 x 4 x 25	DIN 6885
50	03943900	1	1	1	1	1			
51	50345510	1	1	1	1	1			
52	50347400	2	2	2	2	2			
53	01167700	1	1	1	1	1		290 mm	
54	50170700	1	1	1	1	1		M 6 x 16	DIN 912-8.8 A3C
55	50081200	1	1	1	1	1		A 6	DIN 137 A3C
56	50144400	1	1	1	1	1		M 6	DIN 934-8 A3C
57	50158400	1	1	1	1	1			
58	01172400	1	1	1	-	-		800 mm	Gen. B+
58	01171200	-	-	-	1	1		340 mm	Gen. B+
59	50349500	1	1	1	1	1			

A 05

Armaturen
 Electric equipment
 Equipement électrique
 Equipo eléctrico
 Equipaggiamento elettrico

Tafel Nr.
 Tabl. No.
 Tavola N.

19

38 (5-7,17-18,23-28,30-36,40-46)
 39 (5-6,17-18,23-28,30-36,40-46)

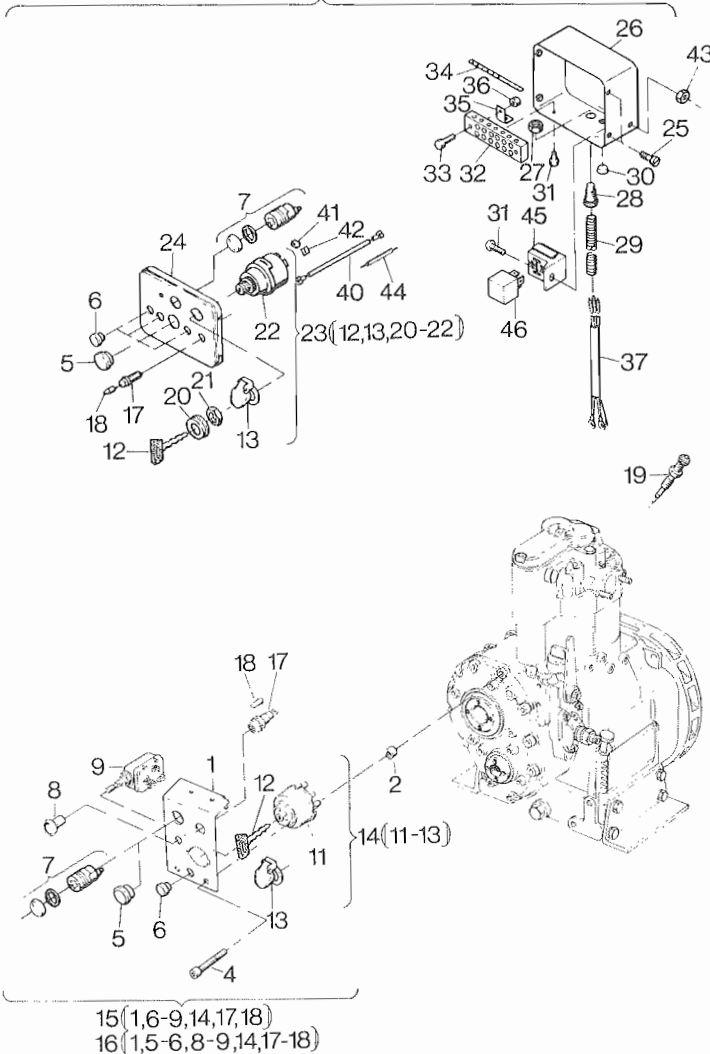

Fig.- No.	HATZ Ident-No.	Stück Qty.					P / W d / D	Bemerkungen Notes
		E 71	E 75	E 79	E780	E786		
1	03508600	1	1	1	1	1		
2	03200400	2	2	2	2	2		
3	-----	-	-	-	-	-		
4	50248800	2	2	2	2	2	M 8 x 60 DIN 912-8.8 A3C	
4	50120900	-	-	-	2	2	„U“ M 8 x 85 DIN 912-8.8 A3C	
5	40091400	1	1	1	1	1	24	
6	40096000	3	3	3	3	3	17	
7	40010900	1	1	1	1	-		
8	40015400	1	1	1	1	1		
9	40009500	1	1	1	1	1		
10	-----	-	-	-	-	-		
11	-----	-	-	-	-	-		
12	50345300	1	1	1	1	1		
13	49050900	1	1	1	1	1		
14	50166100	1	1	1	1	1		
15	00710001	1	1	1	1	-	12 V	
16	01059300	-	-	-	-	1	12 V	
17	50176500	1	1	1	1	1	BATT	
18	40009700	1	1	1	1	1	12 V 2 W	
19	40031200	1	1	1	1	-		
20	-----	-	-	-	-	-		
21	-----	-	-	-	-	-		
22	-----	-	-	-	-	-		
23	50276502	1	1	1	1	1		
24	03509211	1	1	1	1	1		
25	50289200	4	4	4	4	4	M 6 x 12 KZ1-8.8-A3D	
26	00716311	1	1	1	1	1		
27	50159100	1	1	1	1	1		
28	50159010	1	1	1	1	1		
29	03668210	1	1	1	1	1		
30	50160800	2	2	2	2	2		

A 05

Armaturen
 Electric equipment
 Equipement électrique
 Equipo eléctrico
 Equipaggiamento elettrico

Tafel Nr.
 Tabl. No.
 Tavola N.

19

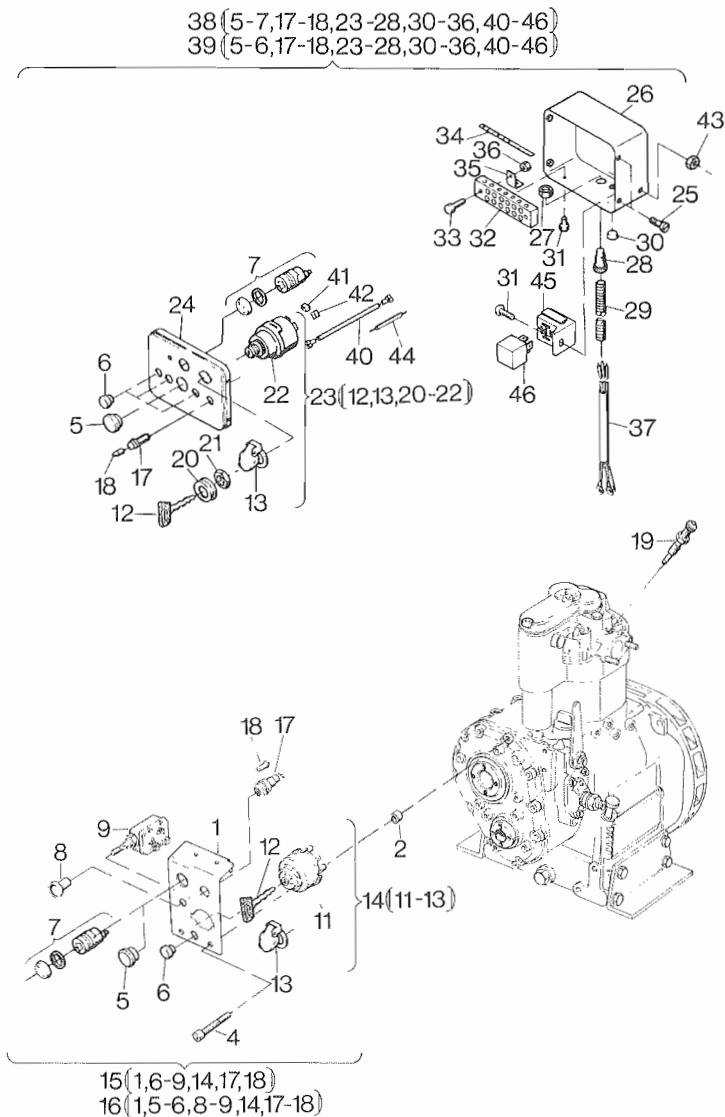

Fig.- No.	HATZ Ident-No.	Stück Qty.					P / W d / D	Bemerkungen Notes
		E 71	E 75	E 79	E780	E786		
31	50049300	3	3	3	3	3	M 5 x 10	DIN 7985-4.8 A3R
32	50160700	1	1	1	1	1		
33	50158800	2	2	2	2	2	M 4 x 20	DIN 84-4.8 A3C
34	05004300	1	1	1	1	1		
35	03666700	2	2	2	2	2		
36	50147100	2	2	2	2	2	M 4	DIN 934-8 A3C
37	01089310	1	1	1	-	-		
37	01092910	-	-	-	1	1		
38	01092002	1	1	1	1	-	12 V	
39	01096102	-	-	-	-	1	12 V	
40	00818203	1	1	1	1	1		
41	50276600	1	1	1	1	1		
42	50276700	1	1	1	1	1		
43	40028200	1	1	1	1	1	M 5	SSN 440-8 Cu
44	01150101	1	1	1	1	1		
45	50276000	1	1	1	1	1		
46	50277701	1	1	1	1	1	12 V	

A 16

Anschlußgehäuse, elast. Kupplung, Wellenstummel
Intermed. housing, flexible coupling, stubshaft
Bride intermediaire, accouplement elast., bout d'arbre
Caja de conexión, acoplamiento elast., eje
Campana accoppiamento, giunto elastico, contralbero

Tafel Nr.
Tabl. No.
Tavola N.

20

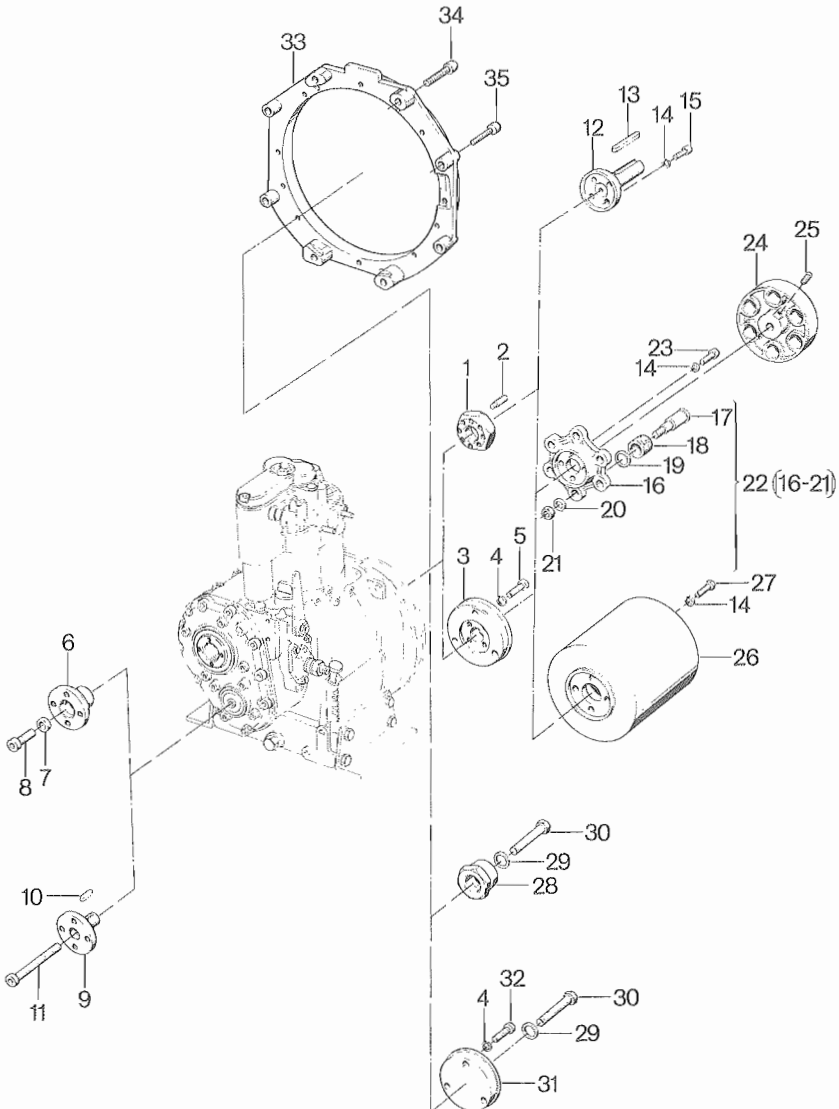

Fig.- No.	HATZ Ident-No.	Stück Qty.					P / W d / D	Bemerkungen Notes
		E 71	E 75	E 79	E780	E786		
1	03011400	1	1	-	-	-		
2	50005100	1	1	-	-	-	M 10 x 25 DIN 915-45 H	
3	03017500	-	-	1	1	1		
4	50002800	-	-	3	3	3	8 DIN 128	
5	50052100	-	-	3	3	3	M 8 x 25 DIN 912-8.8	
6	03002601	1	1	1	1	1		
7	03169901	1	1	1	1	1		
8	50057600	1	1	1	1	1	M 12 x 1,5 x 28 DIN 6912-10.9	
9	03100301	-	-	-	1	1	U	
10	50011000	-	-	-	1	1	U A 6 x 4 x 22 DIN 6885	
11	40094400	-	-	-	1	1	U M 12x1,5x65 DIN 6912-10.9	
12	03027300	1	1	1	1	1		
13	50011700	1	1	1	1	1	A 8 x 7 x 63 DIN 6885	
14	50135600	4	4	4	4	4	10 DIN 128 A3C	
15	50290300	4	4	4	4	4	M 10 x 25 DIN 912-8.8 A3C	
16	03004201	1	1	1	1	1		
17	00307200	6	6	6	6	6		
18	03151000	6	6	6	6	6		
19	03079000	6	6	6	6	6		
20	50017200	6	6	6	6	6	13 DIN 125-St	
21	50023900	6	6	6	6	6	M 12 DIN 934-8	
22	00341801	1	1	1	1	1		
23	50053800	4	4	4	4	4	M 10 x 25 DIN 912-8.8	
24	03004602	1	1	1	1	1		
25	50004600	1	1	1	1	1	AM 8 x 16 DIN 916-45H	
26	03025501	1	1	1	1	1	125 mm	
26	03025601	1	1	1	1	1	150 mm	
26	03025701	1	1	1	1	1	175 mm	
27	50173200	4	4	4	4	4	M 10 x 20 DIN 912-8.8 A3C	
28	03007702	1	1	-	-	-		
28	03013601	-	-	1	1	-		
29	50003600	1	1	1	1	-	B 12 DIN 137	
30	50031900	1	1	1	1	-	M 12 x 80 DIN 931-8.8	
31	03078600	-	-	-	-	1		
32	50052100	-	-	-	-	3	M 8 x 25 DIN 912-8.8	
33	03663300	-	-	-	1	-		
34	50054600	-	-	-	4	-	M 10 x 40 DIN 912-8.8	
35	50052500	-	-	-	4	-	M 8 x 40 DIN 912-8.8	

Kupplung kurz ausrückbar E 71 – E 79
 Clutch short discon. E 71 – E 79
 Embrayage debr. cout. E 71 – E 79
 Embrague momentano E 71 – E 79
 Frizione P.M. E 71 – E 79

Tafel Nr.
 Tabl. No.
 Tavola N.

21

A 17

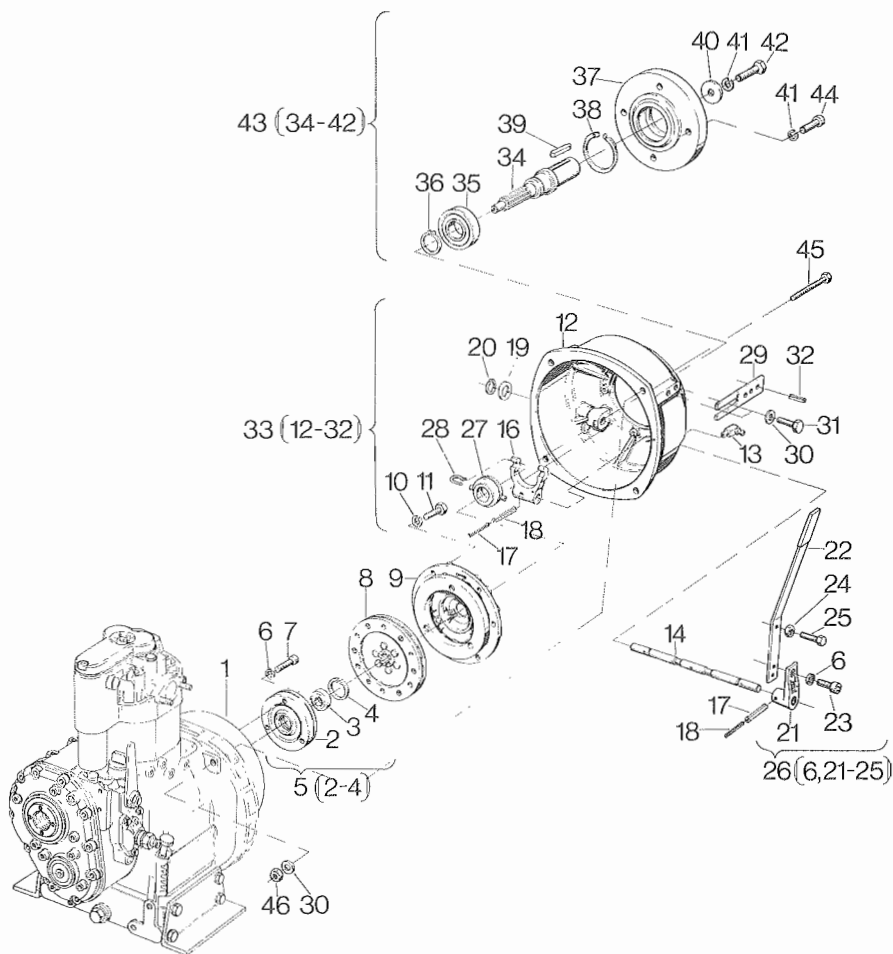

Fig.- No.	HATZ Ident-No.	Stück Qty.					P / W d / D	Bemerkungen Notes	
		E 71	E 75	E 79	E780	E786			
1	00908500	1	1	-	-	-			
2	03016400	1	1	1	-	-			
3	50014500	1	1	1	-	-			
4	50021300	1	1	1	-	-	37 x 1,5	DIN 472	
5	00358000	1	1	1	-	-			
6	50002800	5	5	5	-	-	8	DIN 128	
7	50051900	3	3	3	-	-	M 8 x 20	DIN 912-8.8	
8	40017301	1	1	1	-	-			
9	40003900	1	1	1	-	-			
10	50002700	6	6	6	-	-	6	DIN 128	
11	50025700	6	6	6	-	-	M 6 x 16	DIN 933-8.8	
12	03014200	1	1	1	-	-			
13	50007900	2	2	2	-	-	CM 8 x 1	DIN 71412	
14	03001902	1	1	1	-	-			
15	-----	-	-	-	-	-			
16	03030102	1	1	1	-	-			
17	50035300	2	2	2	-	-	6 x 28	DIN 1481	
18	50034400	2	2	2	-	-	3,5 x 28	DIN 1481	
19	50016700	1	1	1	-	-	8,4	DIN 125-St	
20	50020000	1	1	1	-	-	18 x 1,2	DIN 471	
21	03032000	1	1	1	-	-			
22	-----	-	-	-	-	-			
23	50051600	2	2	2	-	-	M 8 x 16	DIN 912-8.8	
24	50022900	1	1	1	-	-	M 8	DIN 934-8	
25	50027100	1	1	1	-	-	BM 8 x 25	DIN 561-8.8 Zg	
26	00332602	1	1	1	-	-			
27	40015300	1	1	1	-	-			
28	40009200	2	2	2	-	-			
29	03030000	1	1	1	-	-			
30	50145900	6	6	6	-	-	B 10,5	DIN 125-St A3C	
31	50029200	2	2	2	-	-	M 10 x 25	DIN 933-8.8	
32	50059300	2	2	2	-	-	6 x 16	DIN 1481	
33	00450700	1	1	1	-	-			

Kupplung kurz ausrückbar E 71 – E 79
 Clutch short discon. E 71 – E 79
 Embrayage debr. cout. E 71 – E 79
 Embrague momentano E 71 – E 79
 Frizione P.M. E 71 – E 79

Tafel Nr.
 Tabl. No.
 Tavola N.

A 17

21

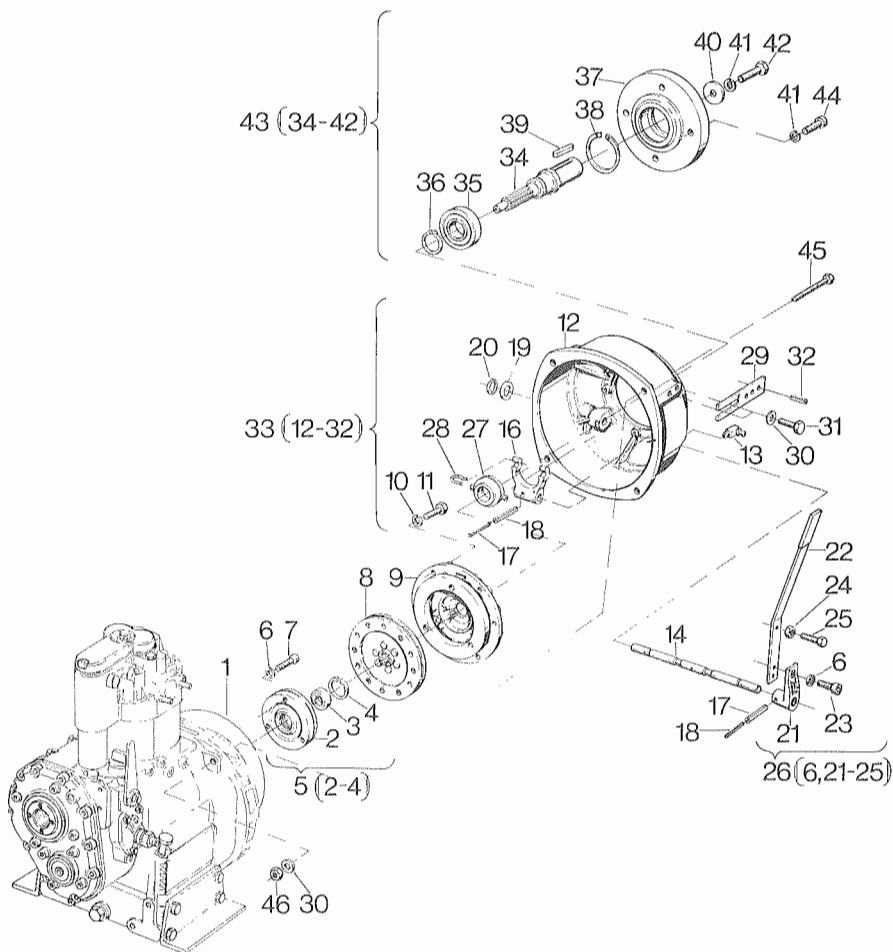

Fig.- No.	HATZ Ident-No.	Stück Qty.					P / W d / D	Bemerkungen Notes
		E 71	E 75	E 79	E780	E786		
34	03015900	1	1	1	-	-		
35	50015000	1	1	1	-	-		
36	50021100	1	1	1	-	-	35 x 1,5 DIN 471	
37	03031701	1	1	1	-	-		
38	40027600	1	1	1	-	-		
39	50012000	1	1	1	-	-	A 10 x 8 x 50 DIN 6885	
40	03321300	1	1	1	-	-		
41	50002900	5	5	5	-	-	10 DIN 128	
42	50029300	1	1	1	-	-	M 10 x 30 DIN 933-8.8	
43	00358200	1	1	1	-	-		
44	50053800	4	4	4	-	-	M 10 x 25 DIN 912-8.8	
45	50055400	4	4	4	-	-	M 10 x 65 DIN 912-8.8	
46	50023500	4	4	4	-	-	M 10 DIN 934-8	

Kupplung kurz ausrückbar E 780 – E 786
 Clutch short discon. E 780 – E 786
 Embrayage debr. cout. E 780 – E 786
 Embrague momentano E 780 – E 786
 Frizione P.M. E 780 – E 786

Tafel Nr.
 Tabl. No.
 Tavola N.

22

A 17

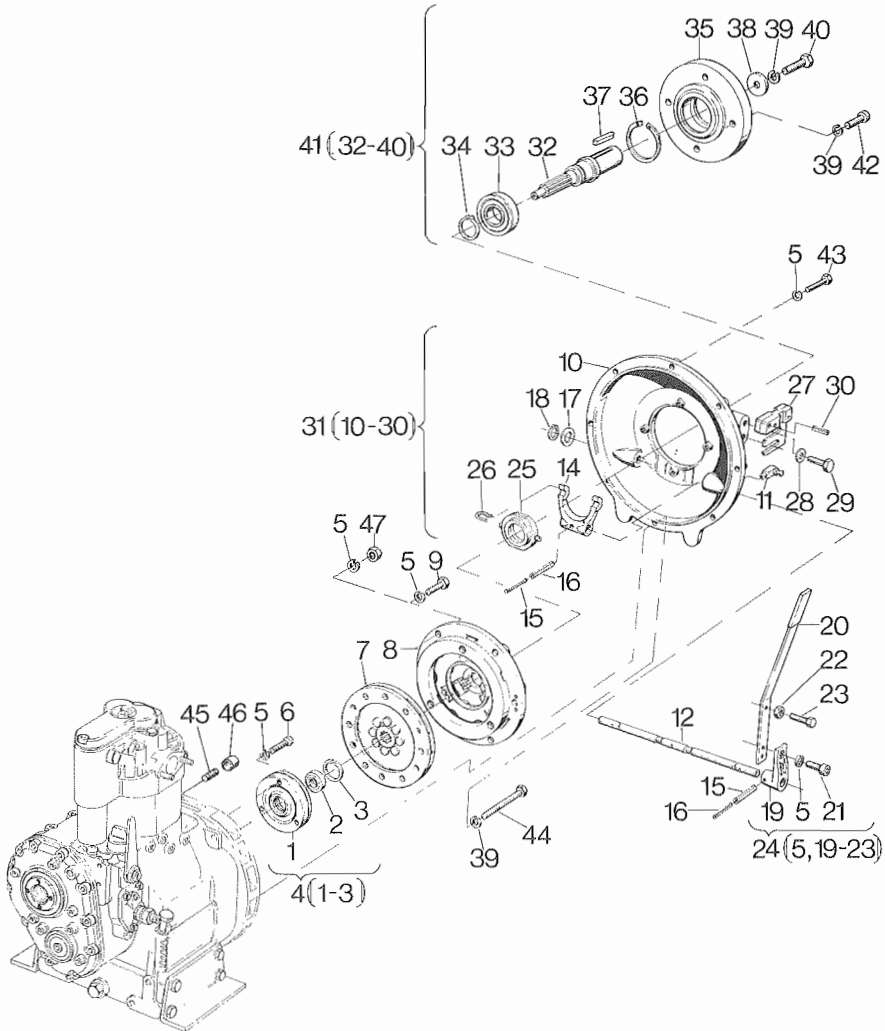

Fig.- No.	HATZ Ident-No.	Stück Qty.					P / W d / D	Bemerkungen Notes	
		E 71	E 75	E 79	E780	E786			
1	03016400	-	-	-	1	1			
2	50014500	-	-	-	1	1			
3	50021300	-	-	-	1	1	37 x 1,5	DIN 472	
4	00358000	-	-	-	1	1			
5	50002800	-	-	-	19	11	8	DIN 128	
6	50051900	-	-	-	3	3	M 8 x 20	DIN 912-8.8	
7	40017401	-	-	-	1	1			
8	40004000	-	-	-	1	1			
9	50026700	-	-	-	6	-	M 8 x 16	DIN 933-8.8	
10	03017700	-	-	-	1	-			
10	03020100	-	-	-	-	1			
11	50007900	-	-	-	2	2	CM 8 x 1	DIN 71412	
12	03029402	-	-	-	1	1			
13	-----	-	-	-	-	-			
14	03030201	-	-	-	1	1			
15	50035300	-	-	-	2	2	6 x 28	DIN 1481	
16	50034400	-	-	-	1	1	3,5 x 28	DIN 1481	
17	50017600	-	-	-	1	1	19	DIN 433-St	
18	50020000	-	-	-	1	1	18 x 1,2	DIN 471	
19	03032000	-	-	-	1	1			
20	-----	-	-	-	-	-			
21	50051600	-	-	-	2	2	M 8 x 16	DIN 912-8.8	
22	50022900	-	-	-	1	1	M 8	DIN 934-8	
23	50027100	-	-	-	1	1	BM 8 x 25	DIN 561-8.8 Zg	
24	00332602	-	-	-	1	1			
25	40015000	-	-	-	1	1			
26	40009200	-	-	-	2	2			
27	03015101	-	-	-	1	1			
28	50145900	-	-	-	2	2	B 10,5	DIN 125-St	
29	50029200	-	-	-	2	2	M 10 x 25	DIN 933-8.8	
30	50059300	-	-	-	2	2			
31	00358100	-	-	-	1	-			
31	00360400	-	-	-	-	1			

Kupplung kurz ausrückbar E 780 – E 786
 Clutch short discon. E 780 – E 786
 Embrayage debr. cout. E 780 – E 786
 Embrague momentano E 780 – E 786
 Frizione P.M. E 780 – E 786

Tafel Nr.
 Tabl. No.
 Tavola N.

22

A 17

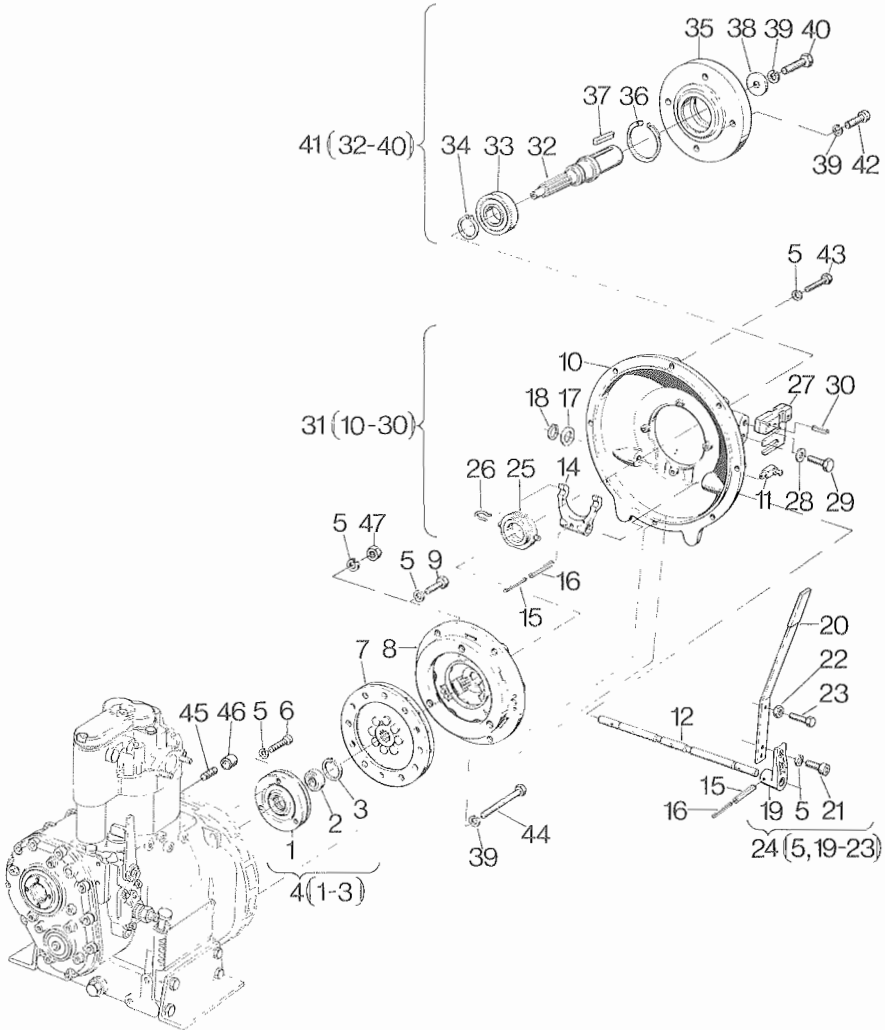

Fig.- No.	HATZ Ident-No.	Stück Qty.					P / W d / D	Bemerkungen Notes
		E 71	E 75	E 79	E780	E786		
32	03015900	-	-	-	1	1		
33	50015000	-	-	-	1	1		
34	50021100	-	-	-	1	1	35 x 1,5 DIN 471	
35	03031701	-	-	-	1	1		
36	40027600	-	-	-	1	1		
37	50012000	-	-	-	1	1	A 10 x 8 x 50 DIN 6885	
38	03321300	-	-	-	1	1		
39	50002900	-	-	-	5	11	10 DIN 128	
40	50029300	-	-	-	1	1	M 10 x 30 DIN 933-8.8	
41	00358200	-	-	-	1	1		
42	50053800	-	-	-	4	4	M 10 x 25 DIN 912-8.8	
43	50027300	-	-	-	8	-	M 8 x 30 DIN 933-8.8	
44	50030100	-	-	-	-	6	M 10 x 65 DIN 931-8.8	
45	50038100	-	-	-	-	6	M 8 x 25 DIN 939-5.6	
46	03935700	-	-	-	-	6	9 x 14 x 6,65	
47	50022900	-	-	-	-	6	M 8 DIN 934-8	

A 18

Anbauteile Hydraulikpumpe
Mount. parts hydr. pump
Pièces mont.-pompe hydr.
Piezas mont. bomba hidraulica
Particolari p. montaggio pompa idraulica

Tafel Nr.
Tabl. No.
Tavola N.

23

Fig.- No.	HATZ Ident-No.	Stück Qty.					P / W d / D	Bemerkungen Notes
		E 71	E 75	E 79	E780	E786		
1	-----	-	-	-	-	-		
2	40033800	1	1	1	1	1		
3	40034700	1	1	1	1	1		
4	50013000	1	1	1	1	1		
5	50015500	1	1	1	1	1		
6	00446300	1	1	1	1	1		
7	40094400	-	-	-	1	1	U M12x1,5x65 DIN 6912-10.9	
8	03105300	4	4	4	4	4		
9	50145900	8	8	8	8	8	B 10,5 DIN 125-St A3C	
9	50145900	4	4	4	4	4	B 10,5 DIN 125-St A3C	
9	50017000	12	12	12	12	12	10,5 DIN 433-St	
10	03177300	4	4	4	4	4		
11	03007200	4	4	4	4	4		
12	03169300	2	2	2	2	2		
12	50058500	-	-	-	2	2	U 8 M 6 x 36 DIN 7-9S20k	
13	03101200	-	-	-	2	2	U	
14	03003100	1	1	1	1	1		
15	50017200	2	2	2	2	2	13 DIN 125-St	
16	50031900	-	-	-	2	2	U M12 x 80 DIN 931-8.8	
17	50031800	2	2	2	2	2	M 12 x 70 DIN 931-8.8 A3C	
18	03006700	1	1	1	1	1		

A 18

Anbauteile Hydraulikpumpe
Mount. parts hydr. pump
Pièces mont.-pompe hydr.
Piezas mont. bomba hidraulica
Particolari p. montaggio pompa idraulica

Tafel Nr.
Tabl. No.
Tavola N.

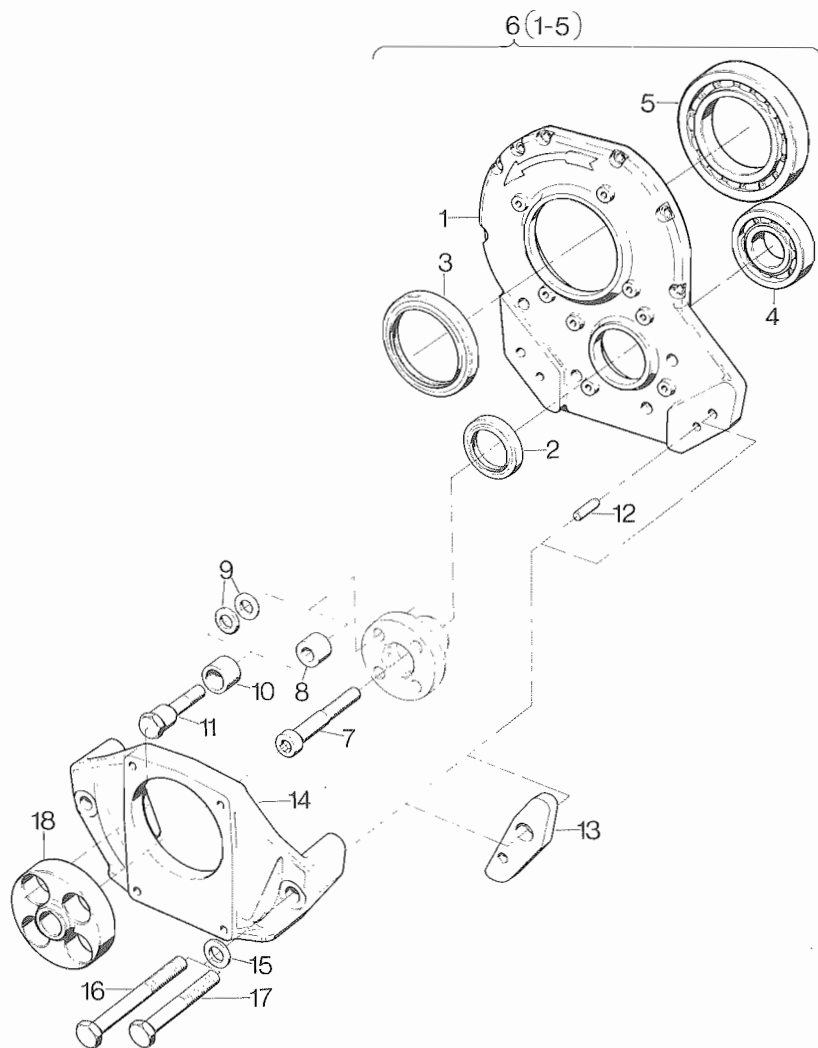
24

Fig.- No.	HATZ Ident-No.	Stück Qty.					P / W d / D	Bemerkungen Notes
		E 71	E 75	E 79	E780	E786		
1	03903600	1	1	1	1	1		
2	03866401	1	1	1	1	1	12,2 x 26 x 6	
3	50002800	4	4	4	4	4	8 DIN 128	
4	50052100	4	4	4	4	4	M 8 x 25 DIN 912-8.8	
5	01122600	1	1	1	1	1		
6	50001000	4	4	4	4	4	A 10 x 16 DIN 7603-Cu	
7	50053500	4	4	4	4	4	M 10 x 16 DIN 6912-8.8	
8	01124900	1	1	1	1	1		
9	50286600	1	1	1	1	1	70 x 90 x 7	
10	-----	-	-	-	-	-		
11	50125600	2	2	2	2	2	M 8 x 12 DIN 914-45 H	
12	50162900	2	2	2	2	2	A 8 x 14 DIN 7603-Cu	
13	03568000	1	1	1	1	1		
14	50095100	4	4	4	4	4	A 8 DIN 137 A3C	
15	50148000	4	4	4	4	4	M 8 DIN 934-8 A3C	
16	50037700	2	2	2	2	2	M 8 x 20 DIN 939-5.6	
17	50037500	2	2	2	2	2	M 8 x 20 DIN 835-5.8	
18	50012400	1	1	1	1	1	5 x 24 DIN 1472	
19	50138900	1	1	1	1	1	M 8 x 12 DIN 912-8.8 C4P	
20	01124801	1	1	1	1	1		
21	-----	-	-	-	-	-		
22	50286500	1	1	1	1	1	50 x 72 x 7	
23	03866600	1	1	1	1	1	M 24 x 1,5	
24	03903401	1	1	1	1	1		
25	50286400	1	1	1	1	1	A 24 x 29 DIN 7603-Cu	
26	01122502	1	1	1	1	1		
27	03913000	1	1	1	1	1		
28	50000900	1	1	1	1	1	A 8 x 11,5 DIN 7603-Cu	
29	50343600	1	1	1	1	1	A 5 x 3 x 25 DIN 6885	
30	03944000	1	1	1	1	1		
31	50345510	1	1	1	1	1		
32	50269800	1	1	1	1	1	B 24 DIN 137	
33	50038600	4	4	4	4	4	M 8 x 45 DIN 835-5.6	
34	50096200	2	2	2	2	2	M 8 x 12 DIN 933-8.8 A3C	

Anhang für nicht abgebildete Zusatzausrüstung:

Weitere Zusatzausrüstungen können aus Platzgründen in der Ersatzteilliste nicht mehr detailliert dargestellt werden. Für die Bestellung von Teilen aus nicht abgebildeten Zusatzausrüstungen verwenden Sie bitte nachfolgende Übersicht. Anhand der Skizze ist die gesuchte Zusatzausrüstung auffindbar, die für den jeweiligen Motortyp zugehörige Ident-Nr. der Ausrüstung ist aus der Tabelle ersichtlich.

Ihre zuständige HATZ-Vertretung kann Ihnen anhand dieser Ident-Nr. das gewünschte Ersatzteil heraussuchen.

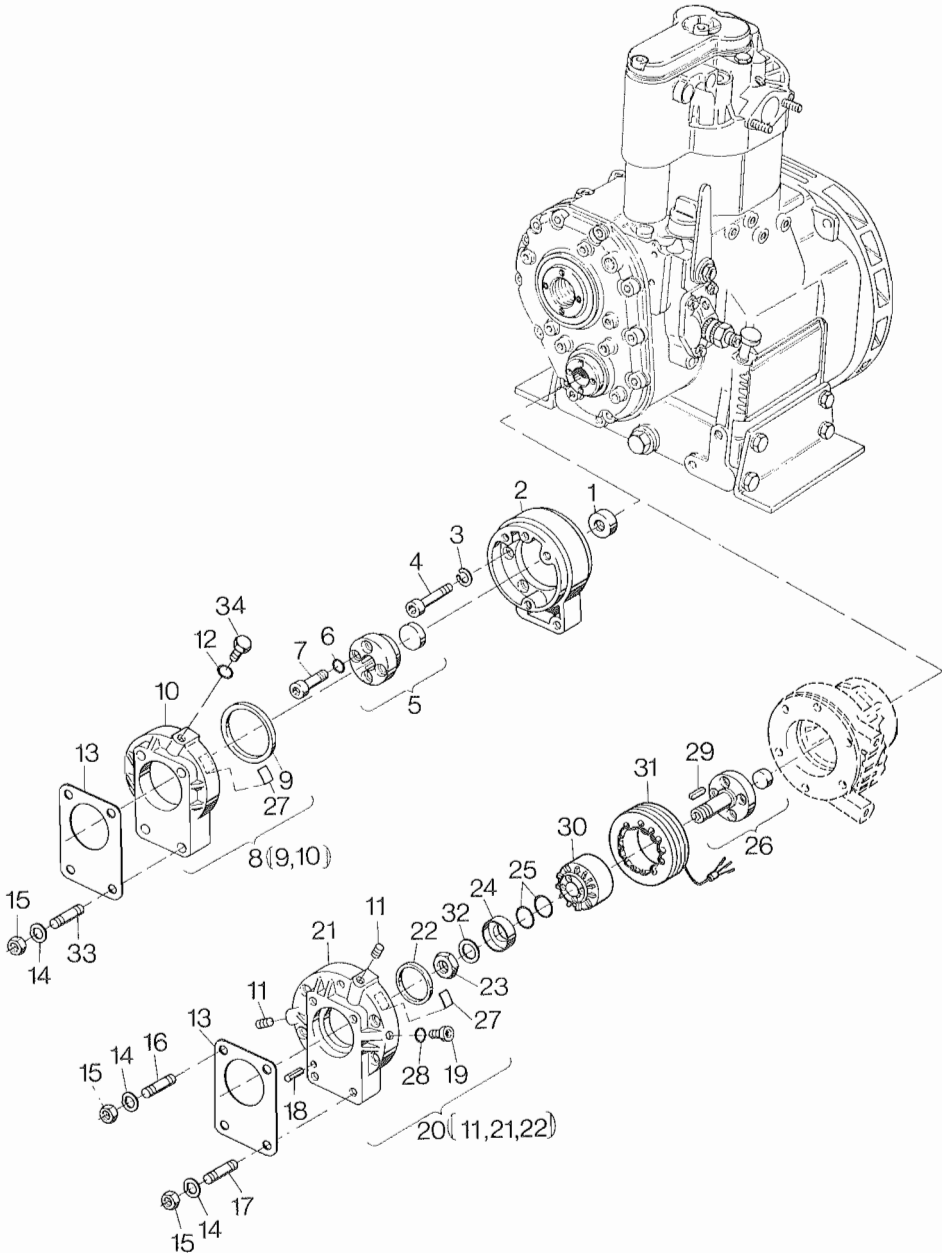
Annex for additional equipment which is not illustrated:

Due to lack of space we cannot list further additional equipment in our parts list: For parts ordering not illustrated, please use the below listed survey. With the aid of sketches you can find the required additional equipment. The ident-number belonging to the corresponding engine type can be taken from the table.

Your HATZ agent is in a position to select for you the required spare part as soon as you have selected the correct ident-number.

Annexe concernant les accessoires complémentaires non-illustrés:

Un certain nombre d'accessoires complémentaires n'ont pu, par suite d'un manque de place, être représentés d'une manière détaillée dans la liste de pièces détachées. Pour la commande de ces accessoires, qui ne sont pas illustrés, veuillez utiliser l'aperçu ci-après. A l'aide des croquis, il est possible de trouver l'accessoire souhaité, le No. ident. correspondant pour chaque type de moteur figure dans le tableau.

Grâce à ce No. ident. votre représentant HATZ pourra vous trouver la pièce souhaitée.

En relación a equipos adicionales no ilustrados:

Debido a razones de espacio no es posible ilustrar otros equipos adicionales en la lista de piezas. Para pedidos de equipos adicionales no ilustrados favor usen la siguiente orientación. A base de las ilustraciones es posible encontrar el equipo adicional buscado, el número ident para el tipo de motor para el cual se necesita el equipo se puede obtener de la tabla.







El representante HATZ para su area puede entonces a base del número ident encontrar las piezas deseadas.

Allegato concernente gli accessori complementari non illustrati:

Un certo numero di accessori complementari non sono stati inseriti in modo dettagliato sul catalogo ricambi per mancanza di spazio. Per effettuare un ordine di questi accessori vogliate utilizzare le tavole che seguono. Con l'aiuto dei disegni è possibile trovare il pezzo desiderato, ed il codice corrispondente per ogni tipo di motore.

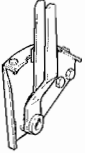
Con il codice del pezzo il vostro concessionario HATZ potrà soddisfare la vostra richiesta.

Zusatzausrüstungen
Equipements
Accessoires complémentaires
Accessori complementari
Equipos

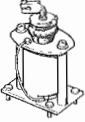
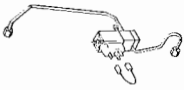
	Code	Ident-No.	E 71				Bemerkungen
			E 75	E 79	E780	E786	Notes
	A 09.20	00447000	1	1	1	1	
	A 09.20	00464700	-	-	1	1	E 780 U, E 786 U
	A 09.40	00447202	1	1	1	1	
	A 11.10	00843802	1	1	1	1	12 V
	A 11.10	00843902	1	1	1	1	24 V
	A 11.10	00447805	1	1	1	1	
	A 11.30	01010800	1	1	-	-	
	A 11.10	01086900	1	1	-	-	12 V
	A 11.10	01087100	-	-	1	-	12 V
	A 11.10	01087900	-	-	1	-	24 V
	A 11.10	01087500	-	-	-	1	12 V

Zusatzausrüstungen
 Equipements
 Accessoires complémentaires
 Accessori complementari
 Equipos

E 71
 E 75 E 79 E780 E786

Bemerkungen
 Notes

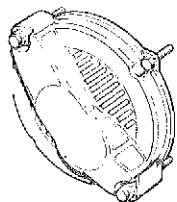

A 12.20 00728200 1 - - -

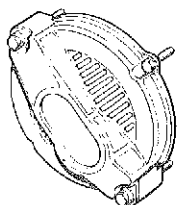

A 12.20 00728100 1 - - -
 A 12.20 01000700 - - 1 -

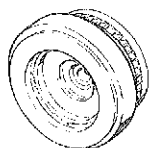

A 14.10 00446701 1 - - - 270 Ø
 A 14.10 00448500 - 1 - - 270 Ø

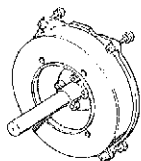

A 15.20 01133000 1 1 - -
 A 16.20 01132100 1 1 - -
 A 15.20 01133400 - - 1 -
 A 16.20 01132100 - - 1 -
 A 15.20 01133600 - - - 1
 A 16.20 01132100 - - - 1

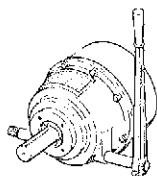

A 17.21 00661601 1 - - -
 A 17.21 00677200 - 1 - -
 A 17.21 00654000 - - 1 -

Zusatzausrüstungen

Equipements

Accessoires complémentaires

Accessori complementari

Equipos

Code

Ident-No.

E 71

E 75

E 79

E780

E786

Bemerkungen

Notes

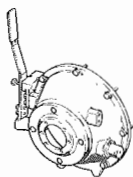

A 20.60	00758000	-	-	1	-
A 20.60	00758102	-	-	-	1

Serien-Nr.-Änderungen
Serial-code modification list
Modification des Nos de serien
Modificación de los Nos de serie
Modifica dei codici

E 71

Bildtafel	Pos. No.	Bestell-Nr.	Stück	Bildtafel	Pos. No.	Bestell-Nr.	Stück	
Table	Fig. No.	Ordering No.	Qty.	Table	Fig. No.	Ordering No.	Qty.	IMT
Planche	Fig. No.	No. référence	Qté.	Planche	Fig. No.	No. référence	Qté.	No.
Tabla	Fig. No.	No. de pedido	Cant.	Tabla	Fig. No.	No. de pedido	Cant.	
Tavola	Rif.	Codice	Q.tà	Tavola	Rif.	Codice	Q.tà	

E 71.15				E 71.16				88.480
--	--	-----	-	18	50	03943900	1	
17	30	01082401	1 ≠	18	51	50345500	1	
17	32	03677200	1 ≠	18	32	50070600	1	
17	33	50269800	1 ≠	18	33	50245100	1	
17	27	03856201	1 ≠	18	27	03856210	1	
--	--	-----	-	24	49	50010800	1	
20	26	01122501	1 =	24	26	01122502	1	
--	--	-----	-	24	29	50343600	1	
--	--	-----	-	24	30	03944000	1	
--	--	-----	-	24	31	50345500	1	
--	--	01159100	1 =	24	32	50269800	1	
--	--	-----	-					

Serien-Nr.-Änderungen
Serial-code modification list
Modification des Nos de serien
Modificación de los Nos de serie
Modifica dei codici

E 75

Bildtafel	Pos. No.	Bestell-Nr.	Stück	Bildtafel	Pos. No.	Bestell-Nr.	Stück	
Table	Fig. No.	Ordering No.	Qty.	Table	Fig. No.	Ordering No.	Qty.	IMT
Planche	Fig. No.	No. référence	Qté.	Planche	Fig. No.	No. référence	Qté.	No.
Tabla	Fig. No.	No. de pedido	Cant.	Tabla	Fig. No.	No. de pedido	Cant.	
Tavola	Rif.	Codice	Q.tà	Tavola	Rif.	Codice	Q.tà	

E 75.14				E 75.15				88.480
--	--	-----	-	18	50	03943900	1	
17	30	01082401	1	≠	18	51	50345500	1
17	32	03677200	1	≠	18	32	50070600	1
17	33	50269800	1	≠	18	33	50245100	1
17	27	03856201	1	≠	18	27	03856210	1
--	--	-----	-	24	26	01122502	1	
20	26	01122501	1	=	24	29	50343600	1
--	--	-----	-	24	30	03944000	1	
--	--	-----	-	24	31	50345500	1	
--	--	01159100	1	=	24	32	50269800	1
--	--	-----	-					

Serien-Nr.-Änderungen
Serial-code modification list
Modification des Nos de serien
Modificación de los Nos de serie
Modifica dei codici

E 79

Bildtafel	Pos. No.	Bestell-Nr.	Stück	Bildtafel	Pos. No.	Bestell-Nr.	Stück	
Table	Fig. No.	Ordering No.	Qty.	Table	Fig. No.	Ordering No.	Qty.	IMT
Planche	Fig. No.	No. référence	Qté.	Planche	Fig. No.	No. référence	Qté.	No.
Tabla	Fig. No.	No. de pedido	Cant.	Tabla	Fig. No.	No. de pedido	Cant.	
Tavola	Rif.	Codice	Q.tà	Tavola	Rif.	Codice	Q.tà	

E 79.14

E 79.15

88.480

--	--	-----	-	18	50	03943900	1	
17	30	01082401	1 ≠	18	51	50345500	1	
17	32	03677200	1 ≠	18	32	50070600	1	
17	33	50269800	1 ≠	18	33	50245100	1	
17	27	03856201	1 ≠	18	27	03856210	1	
--	--	-----	-	24	49	50010800	1	
20	26	01122501	1 =	24	26	01122502	1	
--	--	-----	-	24	29	50343600	1	
--	--	-----	-	24	30	03944000	1	
--	--	-----	-	24	31	50345500	1	
--	--	01159100	1 =	24	32	50269800	1	
--	--	-----	-					

Serien-Nr.-Änderungen
Serial-code modification list
Modification des Nos de serien
Modificación de los Nos de serie
Modifica dei codici

E 780

Bildtafel	Pos. No.	Bestell-Nr.	Stück	Bildtafel	Pos. No.	Bestell-Nr.	Stück	
Table	Fig. No.	Ordering No.	Qty.	Table	Fig. No.	Ordering No.	Qty.	IMT
Planche	Fig. No.	No. référence	Qté.	Planche	Fig. No.	No. référence	Qté.	No.
Tabla	Fig. No.	No. de pedido	Cant.	Tabla	Fig. No.	No. de pedido	Cant.	
Tavola	Rif.	Codice	Q.tà	Tavola	Rif.	Codice	Q.tà	

E 780.14

E 780.15

88.480

--	--	-----	-	18	50	03943900	1	
17	30	01082401	1	≠ 18	51	50345500	1	
17	32	03677200	1	≠ 18	32	50070600	1	
17	33	50269800	1	≠ 18	33	50245100	1	
17	27	03856201	1	≠ 18	27	03856210	1	
--	--	-----	-	24	49	50010800	1	
20	26	01122501	1	= 24	26	01122502	1	
--	--	-----	-	24	29	50343600	1	
--	--	-----	-	24	30	03944000	1	
--	--	-----	-	24	31	50345500	1	
--	--	01159100	1	= 24	32	50269800	1	
--	--	-----	-					

Serien-Nr.-Änderungen
Serial-code modification list
Modification des Nos de serien
Modificación de los Nos de serie
Modifica dei codici

E 786

Bildtafel	Pos. No.	Bestell-Nr.	Stück	Bildtafel	Pos. No.	Bestell-Nr.	Stück	
Table	Fig. No.	Ordering No.	Qty.	Table	Fig. No.	Ordering No.	Qty.	IMT
Planche	Fig. No.	No. référence	Qté.	Planche	Fig. No.	No. référence	Qté.	No.
Tabla	Fig. No.	No. de pedido	Cant.	Tabla	Fig. No.	No. de pedido	Cant.	
Tavola	Rif.	Codice	Q.tà	Tavola	Rif.	Codice	Q.tà	

E 786.10

E 786.11

88.480

--	--	-----	-	18	50	03943900	1	
17	30	01082401	1 ≠	18	51	50345500	1	
				18	32	50070600	1	
17	32	03677200	1 ≠	18	33	50245100	1	
17	33	50269800	1 ≠	18	27	03856210	1	
17	27	03856201	1 ≠	18	49	50010800	1	
--	--	-----	-	24	26	01122502	1	
20	26	01122501	1 =	24	29	50343600	1	
--	--	-----	-	24	30	03944000	1	
--	--	-----	-	24	31	50345500	1	
--	--	01159100	1 =	24	32	50269800	1	
--	--	-----	-					

