

**HATZ**  
DIESEL

Motorenfabrik HATZ GmbH & Co KG  
D-8399 Ruhstorf a. d. Rott  
☎ 08531/319-0 · ☎ 67260 · Telefax 08531/319418

Druck: Kröner, 34/367 - 7.81 - 3.  
Printed in West-Germany

Schutzgebühr DM 3.-  
Protection tax  
Taxe de protection  
Derecho de protección

Ersatzteil-Liste  
Spare parts list  
Liste des pièces de rechange  
Lista de recambios

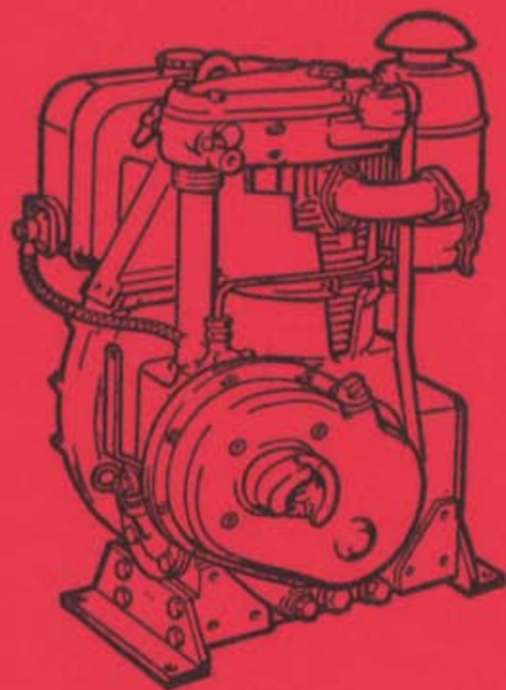

**HATZ**  
DIESEL

**E88G**  
**E88FG**

**E89G**  
**E89FG**

**No. E 88.10**  
**No. E 89.14**



WICHTIG – Bitte Daten eintragen  
IMPORTANT – Compléter les données

IMPORTANT – Please enter data  
IMPORTANTE – Favor completar datos

1.

Bitte hier **Type, Motornummer und Drehzahl** (siehe Motor-Typenschild) eintragen.

Enter here **type engine no. and rpm.** (see engine type-plate).

Indiquer ici le **type, N° de moteur et régime** (voir plaque signalétique).

Insertar aquí **tipo- N° motor y r.p.m.** (vea placa del motor).

MOTORENFABRIK HATZ GmbH & Co. KG  
D-8399 RUHSTORF/ROTT

TYP.	KENNZ.		
MOTOR/FABRIK NO.	ABE/AUSF.		
MIN <sup>-1</sup>	NH	PV	CM <sup>3</sup>

**HATZ**  
**DIESEL**  
MADE IN GERMANY (FED. REP.)

1

2.

Bitte **Ersatzteillistennummer** (siehe Titelseite) gemäß Type ankreuzen, z. B. Typ E 88:

E 88.10

Mark **spare parts list no.** (see title-page) acc. to type, e. g. for type E 88:

E 88.10

Cocher le **N° de liste de pièces de rechange** (voir: couverture) selon type, par. ex. E 88:

E 88.10

Marcar **N° lista de recambios** (ver: frontispició) de acuerdo aipo, ejemplo tipo E 88:

E 88.10



Ersatzteilliste Nr.

Spare parts list no.

Liste des pièces de rechange no.

Lista de recambios no.

E 88.10

E 89.14

2

3.

Bitte tragen Sie hier die **Anschrift** Ihrer nächsten HATZ-Service-stelle ein.

Insert here **address** of your next HATZ Service station.

Indiquer ici **l'adresse** de votre stationservice HATZ la plus proche.

Insertar aquí **dirección** de servicio HATZ más cercano.



HATZ-Service

3

MOTORENFABRIK HATZ  
GmbH & Co. KG  
D - 8399 RUHSTORF a. d. ROTT  
Federal Republic of Germany  
☎ (0 85 31) 319-0 · ☒ 5 7260

### Angaben bei Ersatzteilbestellungen:

Zur richtigen und schnellen Belieferung mit Ersatzteilen sind folgende Angaben erforderlich.

1. **Type, Motornummer und Drehzahl** des Motors, für den das Ersatzteil benötigt wird: siehe Angaben auf Seite 1, Feld 1.
2. **Nummer der Ersatzteilliste**, aus der die Bestellnummer herausgelesen wurde: siehe Seite 1, Feld 2.
3. **Stückzahl und Bestell-Nr.** des gewünschten Ersatzteils.
4. Gewünschte **Versandart**, z. B. Post, Luftfracht, Express.
5. Genaue **Versandadresse**, wenn erforderlich mit Post- u. Bahnstation.

### Bestellbeispiel:

Für Motortype: E 88 FG - 190j  
Motornummer: 551090005561  
min<sup>-1</sup>: 2300/60

aus Ersatzteilliste E 88.10

folgende Teile:

Stück	Bestell-Nr.
2	003 351 00
6	031 684 00

per Postexpress an ...

### Die Ersatzteilbestellung richten Sie bitte an:

— die nächste HATZ-Servicestelle, Anschrift siehe Seite 1, Feld 3 oder separates Servicestellenverzeichnis

— oder an die

Motorenfabrik Hatz GmbH & Co. KG  
D - 8399 Ruhstorf a. d. Rott  
Federal Republic of Germany  
☎ (08531) 319-0 — ☎ 57260

### Particulars for spare parts orders:

The following information is needed to ensure correct and prompt supply of spare parts:

1. **Engine type, engine number and r.p.m.** of the engine for which you need the spare part.  
See particulars on page 1, field 1.
2. **Number of spare parts list** from which you took the ordering no., see page 1, field 2.
3. **Quantity and ordering no.** of requested spare part.
4. Requested **mode of dispatch**, e. g. surface/airmail, airfreight, express.
5. Exact **shipping address**, if necessary indicate local post office and/or railway station.

### Example for your order:

For engine type: E 88 FG - 190j  
Engine number: 551090005561  
R. p. m.: 2300/60

Spare parts list no. E 88.10

The following parts:

Qty.	ordering-no.
2	003 351 00
6	031 684 00

to be mailed, express, to ...

### Please address your spare parts order to:

— your nearest Hatz service station, address see page 1, field 3 or separate Hatz-service-List

— or to

Motorenfabrik Hatz GmbH & Co. KG  
D - 8399 Ruhstorf a. d. Rott  
Federal Republic of Germany  
☎ (08531) 319-0 — ☎ 57260

### Données à indiquer lors de vos commandes de pièces détachées:

Pour nous permettre de livrer vos pièces rapidement et correctement, nous avons besoin des données suivantes:

1. **Type, No. et régime du moteur** pour lequel vous avez besoin de pièces: voir données page 1, carré 1.
2. **No. de la liste de pièces de rechange** dans laquelle figure le No. de commande: voir page 1, carré 2.
3. **Quantité et No. de commande** de la pièce souhaitée.
4. **Mode d'expédition** souhaitée: par ex. par poste, frêt aérien, exprès.
5. **Adresse exacte de destination** et, lorsque ceci est nécessaire, le nom de la poste ou de la gare, ou aéroport.

#### Exemple:

Pour type de moteur: E 88 FG - 190j  
No. moteur: 551090005561  
Régime: 2300/60

Liste de pièces de rechange: E 88.10

Les pièces suivantes:

Qté	No. commande
2	003 351 00
6	031 684 00

par poste exprès à . . . .

#### Les commandes de pièces détachées sont à adresser à:

— votre station-service HATZ la plus proche, voir adresse page 1, carré 3 ou liste de service séparée.

— ou

Motorenfabrik Hatz GmbH & Co. KG  
D - 8399 Ruhstorf a. d. Rott  
République Fédérale d'Allemagne  
☎ (08531) 319-0 — ☎ 5 7260

### Datos para pedidos de recambios:

Para recibir sus recambios en forma rápida y correcta necesitamos las siguientes informaciones:

1. **Tipo, número del motor y revoluciones:**  
ver detalles en página 1, posición 1.
2. **Número de la lista de recambios** de la cual se ha obtenido el número de pedido: ver página 1, posición 2.
3. **Cantidad y número de pedido** del recambio deseado.
4. Tipo de **despacho deseado:** por ej. correo, flete aéreo, expreso etc.
5. **Dirección exacta**, si necesario indicar la oficina de correo, la estación ferroviaria o aeropuerto.

#### Ejemplo de pedido:

Para motor tipo: E 88 FG - 190j  
Número de motor: 551090005561  
R. P. M.: 2300/60

De la lista de recambios: E 88.10

Siguientes recambios:

Cantidad	Número de pedido
2	003 351 00
6	031 684 00

Por correo expreso para . . . .

#### El pedido de recambios favor dirigirlo a:

— Al servicio HATZ más cercano, dirección verla en página 1, posición 3 or en el índice separado de direcciones de servicio.

— Alternativa a:

Motorenfabrik Hatz GmbH & Co. KG  
D - 8399 Ruhstorf a. d. Rott  
República Federal de Alemania  
☎ (08531) 319-0 — ☎ 5 7260

	<b>Inhaltsverzeichnis:</b>	<b>Index:</b>	<b>Tafel No. Table No.</b>
M . . .	Grundmotor	Basic engine	
00, 34	Ersatzteilsätze, Zubehör	Spare part kits, accessories	01
01	Kurbelgehäuse	Crankcase	02, 03
02, 03	Kurbelwelle	Crankshaft	04
05, 06	Kolben, Pleuel, Zylinder	Piston, conrod, cylinder	05
07	Zylinderkopf	Cylinder head	06
04, 09	Nockenwelle, Stoßstangen,	Camshaft, pushrod,	07
10, 11 14	Ölpumpe, Steuergehäuse Einspritzausrüstung	oil pump, governor housing Injection equipment	08
17, 26	Schwungrad, Luftführung	Flywheel, air ducting	09
A . . .	Zusatzausrüstung	Equipments	
01	Kraftstoffbehälter, Absperrventil, Leitungen	Fuel tank, shut off valve, pipes	10
01	Filter, Leitungen	Filter, pipes	11
02	Luftfilter	Air filter	12
03	Auspufftopf	Exhaust silencer	13
04	Andrehkurbel, Andrehvorrichtung schs.	Starting handle, starting device flywheel side	14
04, 12	Andrehkurbel, Keilriemenschutz	Starting handle, v-belt guard	15
04, 07	Dekompression, Öleinfüllung	Decompression, oil filling	16
05	Starter, Armaturen	Starter, electric equipment	17
05	Generator	Alternator	18
16	Steuergehäuse, elast. Kupplung, Wellenstummel	Governor housing, flexible coupling, stubshaft	19
17	Kupplung kurzaustrückbar	Clutch short discon.	20
17, 07	Kupplung daueraustrückbar, Ölkühler	Clutch perm. disconn., oil cooler	21
20, 21	Untersetzungsgetriebe	Reduction gear	22
			<b>Seite/Page</b>
	Zusatzausrüstungen	Equipements	69-70
	Serien-Nr.-Änderungen	Serial-code modification list	71-72

	<b>Sommaire:</b>	<b>Indice:</b>	
M . . .	<b>Motor de base</b>	<b>Moteur de base</b>	
00, 34	Jeux de pièces de rechange, accessoires	Juegos de piezas de recambio, accesorios	01
01	Carter moteur	Caja cigueñal	02, 03
02, 03	Vilebrequin	Cigüeñal	04
05, 06	Piston, bielle, cylindre	Embolo, biela, cilindro	05
07	Culasse	Culata	06
04, 09 10, 11	Arbre à cames, tige de culbut., pompe à huile, carter distribution	Arbol de levas, varilla de balancin, bomba de aceite, caja de mando	07
14	Equipement d'injection	Equipo de inyección	08
17, 26	Volant, carter ventilation	Volante, conduccion de aire	09
A . . .	<b>Accessoires</b>	<b>Equipos</b>	
01	Reservoir à carburant, soupape d'arrêt, filtre conduites	Depósito combustible, valvula de parada, filtro tubería	10
01	Filtre, conduites	Filtro, tubería	11
02	Filtre à air	Filtro de aire	12
03	Silencieux	Silenciador	13
04	Manivelle, dispositif démarrage	Manivela, dispositivo de arranque	14
04, 12	Manivelle, protection courroie	Manivela, revestimiento	15
04, 07	Décompression, remplissage huile	Decompresión, tubuladura	16
05	Démarrreur, equipment électrique	Arrancador, equipo eléctrico	17
05	Alternateur	Alternador	18
16	Carter distribution, accouplement elast., bout d'arbre	Caja de mando, acoplamiento elast., eje	19
17	Embrayage depr. cout.	Embrague momentano	20
17, 07	Embrayage depr. continu., radiateur huile	Embrague permanente, radiador de acéite	21
20, 21	Reducteur	Reductor	22
			Page / Pagina No.
	Accessoires complémentaires	Equipos	69-70
	Modification des Nos de serien	Modificación de los Nos de serie	71-72





Fig. No.	Bestell-Nr. Ordering No. No. référence No. de pedido	Stück Quantity Quantités Cantidades	Hinweise Hints Indications Indicaciones	
----------	---	--	--	--

E 88 | E 89

P: Im Pannensatz enthalten. — Incl. in emergency kit. — Contenu dans le jeu secours. — Incluido en el juego para averías.  
W: Im Wartungssatz enthalten. — Incl. in maintenance kit. — Contenu dans le jeu d'entretien. — Incluido en el juego de mantenimiento.  
1: Anzahl pro Satz. — Qty. per kit. — Quantite par jeu. — Cantidad por juego.  
d: Im Dichtungssatz f. 1 Zyl.-K. enthalten. — Incl. in gasket set f. 1 cyl. head. — Contenu dans le jeu de joint p. 1 culasse. — Incluido en el juego de juntas p. 1 culata.  
D: Im Dichtungssatz Kurbelgeh. enth. — Incl. in gasket set crankcase. — Contenu dans le jeu de joints carter moteur. — Incluido en el juego de juntas caja cigüeñal.

1	003 333 10 P1	1	1	Dichtungssatz für 1 Zylinderkopf Gasket set for 1 cyl. head Jeu de joint p. 1 culasse Juego de juntas para 1 culata
2	012 300 00	1	1	Dichtungssatz Kurbelgehäuse Gasket set crankcase Jeu de joints carter moteur Juego de juntas caja cigüeñal
3	009 616 01	1	1	Wartungssatz für 1000 h 1000 hours maintenance kit Kit d'entretien 1000 heures Juego de piezas para mantenimiento 1000 horas
4	009 663 04	1	1	Pannensatz Emergency kit Kit de secours Juego para averías
5	004 522 01	1	1	Zubehörsatz Accessories kit Sort. accessoires Juego de accesorios
6	036 314 01	1	1	
7	033 963 01	1	1	
8	033 968 00	1	1	

Dicht- und Klebstoffe  
Sealing- and bonding adhesives

Etanchéifiant et Colle  
Materias para empaquetar y pegar

A =	502 230 00	Loctite Activator N	— 165 ml
B =	502 231 00	Loctite 573	— 50 ml
C =	502 232 00	Loctite 601	— 50 ml
D =	502 233 00	Loctite 221	— 50 ml
E =	502 234 00	Loctite 648	— 10 ml
F =	502 238 00	Technicoll 8058	— 0,750 kg
+ =	502 239 00	Technicoll 8366	— 0,750 kg
G =	502 565 01	Loctite IS 407	— 20 ml
H =	502 825 01	Silicon	— 30 ml
J =	502 830 00	Hochtemp. Paste	— 250 g

s. Hinweis auf den einzelnen Bildtafeln  
as specified in the individual tables  
suivant les remarques sur les tableau  
correspondant  
Según las indicaciones de las tablas  
correspondientes



Fig. No.	Bestell-Nr. Ordering No. No. référence No. de pedido	Stück Quantity Quantités Cantidades		Hinweise Hints Indications Indicaciones	
		E 88	E 89		
1	---	---	---		
2	---	---	---		
3	---	---	---		
4	500 436 00	2	2	M 10 x 1	DIN 906
5	500 373 00	11	11	M 8 x 18	DIN 835-10.9
6	500 367 00	2	2	6 x 22	DIN 1474
7	030 258 02	1	1		
8	502 376 00	1	1		
9	003 336 02	1	1		
10	032 255 03	1	1		
11	400 025 00	4	4		

M 01

Kurbelgehäuse  
Crankcase  
Carter moteur  
Caja cigueñal

Tafel Nr.  
Tabl. No.

03

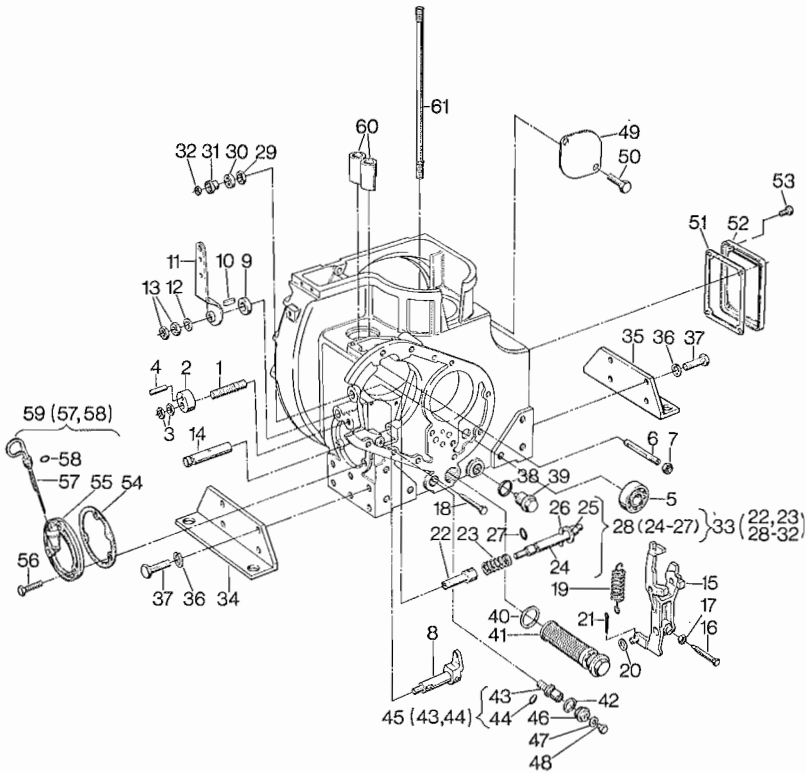

Fig. No.	Bestell-Nr. Ordering No. No. référence No. de pedido	Stück Quantity Quantités Cantidades		Hinweise Hints Indications Indicaciones	
		E 88	E 89		
1	500 407 00	1	1	M 10 x 30	DIN 939-5.6
2	030 222 00	1	1		
3	500 238 00	2	2	BM 10	DIN 439-6
4	500 124 00	1	1	5 x 24	DIN 1472
5	500 147 00	1	1	6304	DIN 625
6	031 567 00	1	1		
7	500 232 00	1	1	BM 8	DIN 439-5
8	003 024 01	1	1		
9	031 462 01	1	1		
10	500 106 00	1	1	A 4 x 4 x 14	DIN 6885
11	007 342 00	1	1		
12	501 459 00	1	1	B 10,5	DIN 125-St A3C
13	500 238 00	2	2	BM 10	DIN 439-6
14	030 214 00	1	1		
15	003 337 10	1	1		
16	500 262 00	1	1	BM 6 x 30	DIN 561-8.8
17	500 227 00	1	1	M 6	DIN 934-8
18	500 262 00	1	1	BM 6 x 30	DIN 561-8.8
19	034 307 00	1	1	2,7 mm $\phi$	1500 min <sup>-1</sup> Gen.
19	032 874 00	1	1	3,0 mm $\phi$	1800 min <sup>-1</sup> Gen.
19	037 714 00	1	1	3,1 mm $\phi$	2170, 2350 min <sup>-1</sup> Gen.
19	034 399 00	1	1	3,3 mm $\phi$	$\leq$ 2100 min <sup>-1</sup>
19	031 460 01	1	1	3,7 mm $\phi$	$>$ 2100 min <sup>-1</sup>
20	031 332 00	1	1		
21	500 361 00	1	1	2 x 22	DIN 94
22	030 360 00	1	1		
23	031 602 00	1	1		
24	—	—	—		
25	—	—	—		
26	—	—	—		
27	501 537 00 D1	1	1	4,48 x 1,78	
28	003 353 01	1	1		
29	500 240 00	1	1	M 12	DIN 936-17 H
30	031 603 00	1	1		
31	030 398 01	1	1		
32	031 604 00	1	1		

M 01

Kurbelgehäuse  
Crankcase  
Carter moteur  
Caja cigüeñal

Tafel Nr.  
Tabl. No.

03

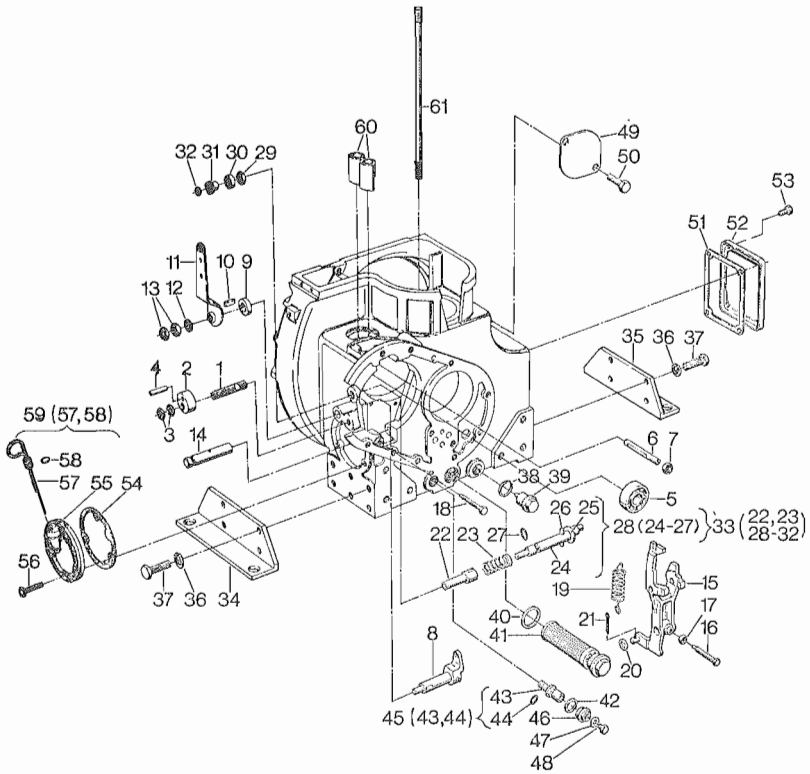

Fig. No.	Bestell-Nr. Ordering No. No. référence No. de pedido	Stück Quantity Quantités Cantidades		Hinweise Hints Indications Indicaciones	
		E 88	E 89		
33	004 416 01	1	1		
34	030 319 00	1	1		
35	030 338 00	1	1		
36	500 029 00	8	8	10	DIN 128
37	500 293 00	8	8	M 10 x 30	DIN 933-8.8
38	500 015 00 W7, D1	1	1	A 21 x 26	DIN 7603-Cu
39	031 691 03 W1	1	1		
40	500 018 00 W7, D1	1	1	A 30 x 36	DIN 7603-Cu
41	003 287 02	1	1		
42	500 016 00 D1	1	1	A 22 x 27	DIN 7603-Cu
43	---	---	---		
44	400 227 00 D1	1	1		
45	003 288 01	1	1		
46	033 272 00	1	1		
47	500 624 00	1	1	A 10 x 13,5	DIN 7603-Cu
48	500 623 00	1	1	M 10 x 1	DIN 908-4.6 A3C
49	030 331 00	1	1		
50	500 308 00	2	2	M 12 x 16	DIN 933-8.8
51	031 461 00 D1	1	1		
52	030 216 01	1	1		
53	500 267 00	4	4	M 8 x 16	DIN 933-8.8
54	031 560 00 D1	1	1		
55	031 559 01	1	1		
56	500 270 00	3	3	M 8 x 25	DIN 933-8.8
57	---	---	---		
58	400 224 00 D1	1	1	8 x 2	
59	004 425 00	1	1		
60	031 598 00	2	2		
61	031 483 00	4	4		

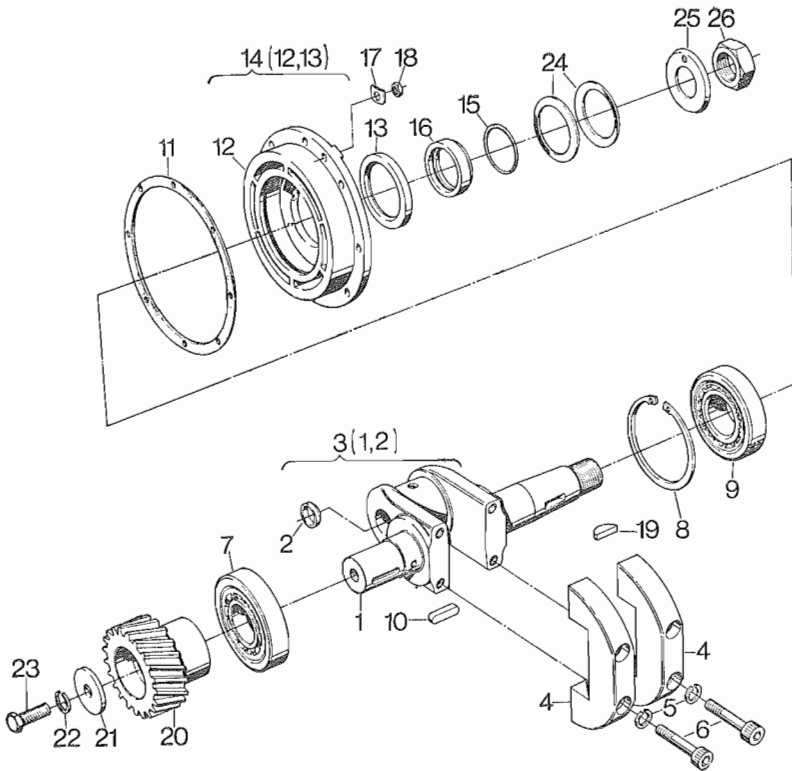



Fig. No.	Bestell-Nr. Ordering No. No. référence No. de pedido	Stück Quantity Quantités Cantidades		Hinweise Hints Indications Indicaciones	
		E 88	E 89		
1	—	—	—		
2	500 432 00	1	1	25	DIN 443
3	003 339 01	1	1		
4	030 359 01	2	2		
5	500 029 00	4	4	10	DIN 128
6	500 550 00	4	4	M 10 x 50	DIN 912-10.9
7	500 476 00	1	1	NJ 309 E C3	DIN 5412
8	500 221 00	1	1	100 x 3	DIN 472
9	500 489 00	1	1	NUP 309 E C3	DIN 5412
10	500 119 00	1	1	A 10 x 8 x 35	DIN 6885
11	031 464 01 D1	1	1		
12	—	—	—		
13	500 454 00 D1	1	1	55 x 70 x 8 BB	
14	003 273 01	1	1		
15	400 237 00 D1	1	1	45 x 2	
16	030 287 01	1	1		
17	500 188 00	8	8	8,4	DIN 432
18	500 229 00	8	8	M 8	DIN 934-8
19	500 181 00	1	1	8 x 11	DIN 6888
20	030 275 02	1	1	15 <sup>0</sup>	
21	030 211 00	1	1		
22	500 030 00	1	1	12	DIN 128
23	500 312 00	1	1	M 12 x 30	DIN 933-8.8
24	031 463 00	2	2		
25	031 986 00	1	1		
26	032 853 00	1	1		

**M 05**

Kolben, Pleuel  
Piston, conrod  
Piston, bielle  
Embolo, biela

**M 06**

Zylinder  
Cylinder  
Cylindre  
Cilindro

Tafel Nr.  
Tabl. No.

**05**

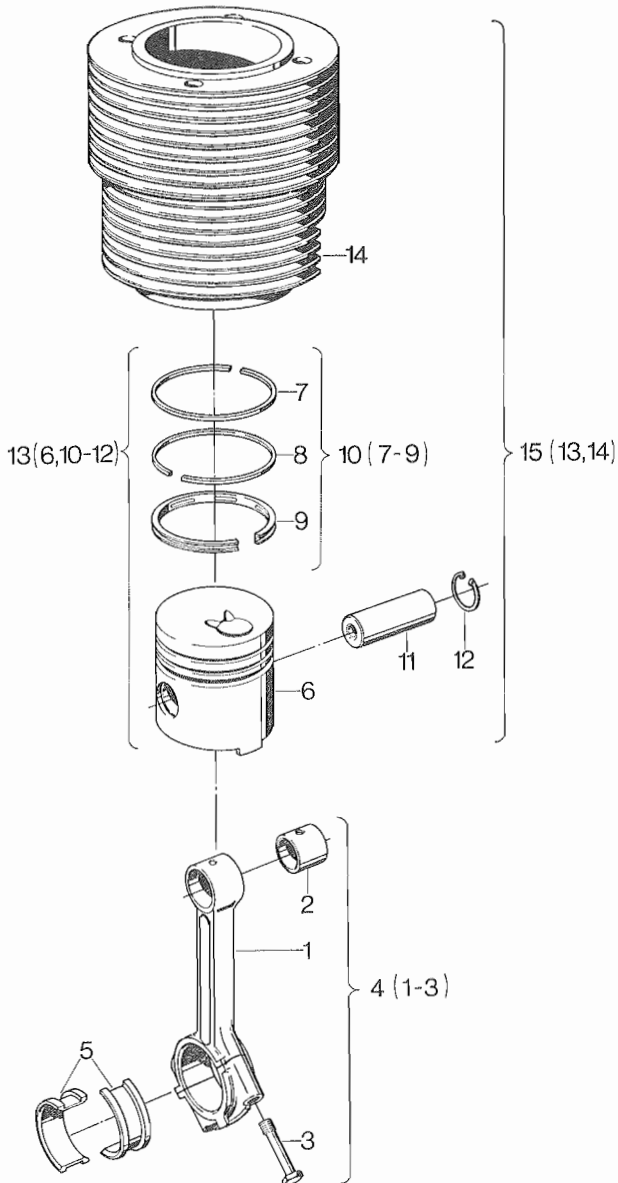

Fig. No.	Bestell-Nr. Ordering No. No. référence No. de pedido	Stück Quantity Quantités Cantidades		Hinweise Hints Indications Indicaciones
		E 88	E 89	
1	—	—	—	
2	030 215 00	1	1	
3	031 467 01	2	2	
4	003 011 01	1	1	
5	031 465 01	1	1	
5	031 466 01	1	1	— 0,5 mm
6	—	—	—	
7	—	—	—	
8	—	—	—	
9	—	—	—	
10	005 710 10	1	1	
10	012 354 00	1	1	+ 0,5 mm
10	005 711 10	1	1	+ 1,0 mm
11	501 005 01	1	1	
12	500 208 00	2	2	30 x 1,2      DIN 472
13	003 347 02	1	1	
13	012 353 00	1	1	+ 0,5 mm
13	003 348 02	1	1	+ 1,0 mm
14	—	—	—	
15	009 923 00	1	—	
15	005 656 00	—	1	

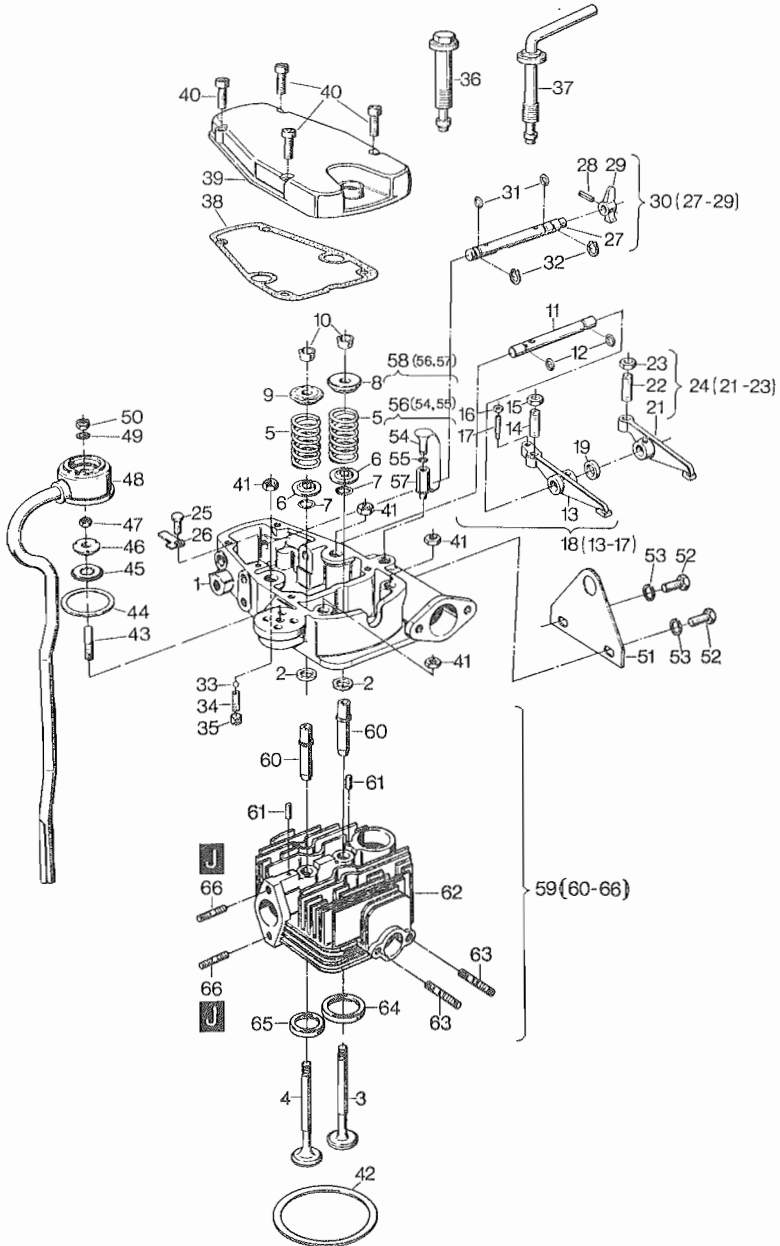

Fig. No.	Bestell-Nr. Ordering No. No. référence No. de pedido	Stück Quantity Quantités Cantidades		Hinweise Hints Indications Indicaciones	
		E 88	E 89		
1	030 370 04	1	1		
2	031 487 00 d2	2	2		
3	030 388 10	1	1		
4	030 389 10	1	1		
5	031 587 01	2	2		
6	031 491 00	2	2		
7	400 225 00 d2	2	2		
8	030 223 10	1	1		
9	030 356 10	1	1		
10	037 863 00	2	2		
11	031 489 01	1	1		
12	400 223 00 d4	2	2		
13	—	—	—		
14	030 221 00	1	1		
15	031 490 00 W2	1	1		
16	500 227 00	1	1	M 6	DIN 934-8
17	030 220 01	1	1		
18	003 280 01	1	1		
19	030 344 01	1	1	4,0 mm	
19	034 053 00	1	1	4,1 mm	
19	034 007 00	1	1	4,2 mm	
19	034 008 00	1	1	4,3 mm	
20	—	—	—		
21	—	—	—		
22	030 221 00	1	1		
23	031 490 00 W2	1	1		
24	003 279 01	1	1		
25	500 255 00	1	1	M 6 x 12	DIN 933-8.8
26	500 187 00	1	1	6,4	DIN 463-St
27	—	—	—		
28	500 346 00	1	1	4 x 18	DIN 1481
29	031 734 01	1	1		
30	009 222 00	1	1		
31	400 223 00 d4	2	2		
32	500 195 00	2	2	12 x 1	DIN 471
33	500 098 00	1	1	6 mm III	DIN 5401

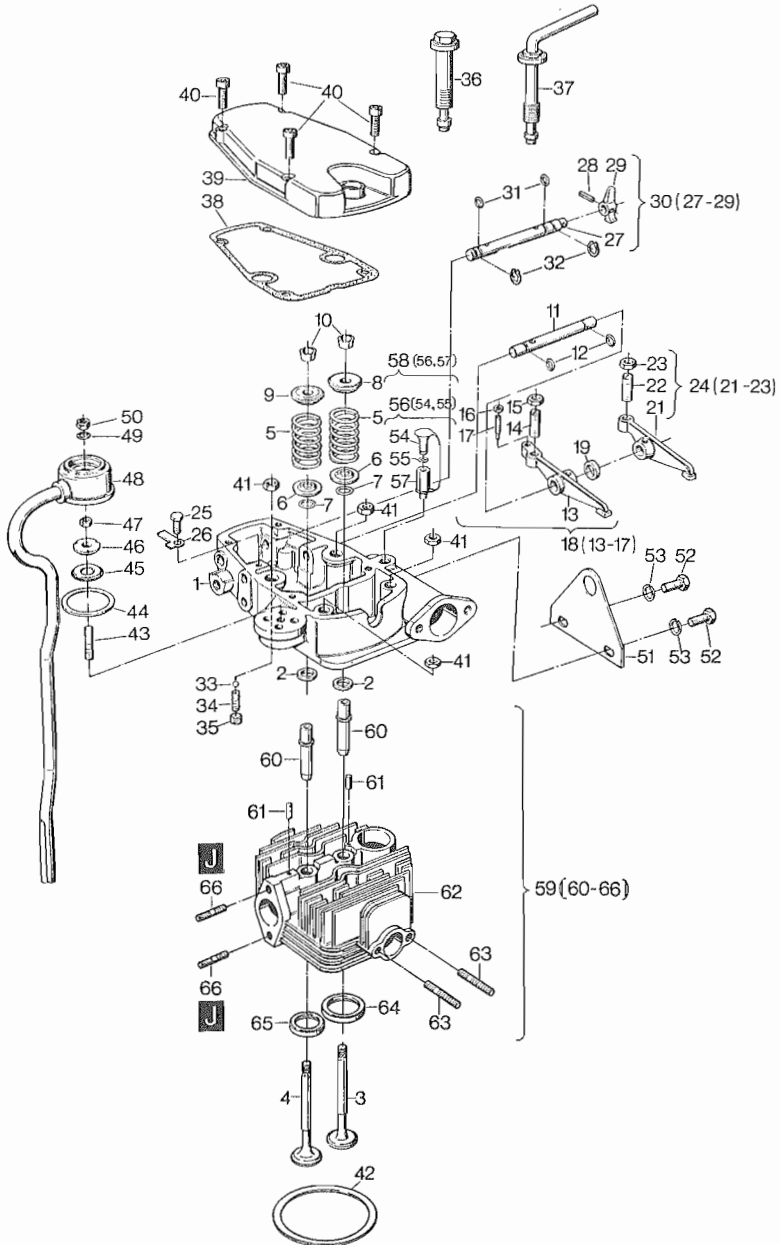

Fig. No.	Bestell-Nr. Ordering No. No. référence No. de pedido	Stück Quantity Quantités Cantidades		Hinweise Hints Indications Indicaciones	
		E 88	E 89		
34	031 591 00	1	1		
35	030 795 00	1	1		
36	003 281 00	1	1		
37	003 282 00	1	1		
38	031 597 01 W3, d1	1	1		
39	031 596 02	1	1		
40	500 522 00	4	4	M 8 x 30	DIN 912-8.8
41	500 239 00 P4	4	4	M 12	DIN 934-8
42	032 682 00 d1	1	1	0,5 mm	
42	031 586 00	0 ... 1	0 ... 1	0,6 mm	
42	031 593 00 d1	0 ... 1	0 ... 1	0,7 mm	
42	031 594 00	0 ... 1	0 ... 1	0,8 mm	
42	031 595 00	0 ... 1	0 ... 1	0,9 mm	
43	031 590 01	1	1		
44	031 589 00 d1	1	1		
45	031 497 00	1	1		
46	031 588 00	1	1		
47	500 229 00 P2	1	1	M 8	DIN 934-8
48	003 043 03	1	1		
49	031 332 00 P1	1	1	13 x 8,4 x 2	
50	400 284 00 P1	1	1	M 8	SSN 440-8 Cu
51	033 296 00	1	1		
52	500 292 00	2	2	M 10 x 25	DIN 933-8.8
53	500 029 00	2	2	10	DIN 128
54	—	—	—		
55	400 817 00 d2	2	2	12 x 2	
56	007 363 00 P1	1	1		
57	—	—	—		
58	009 507 00	1	1		
59	003 349 01	1	1		
60	031 484 01	2	2		
61	500 365 00	2	2	5 x 12	DIN 1474
62	—	—	—		
63	500 383 00	2	2	M 8 x 30	DIN 835-5.8
64	—	—	—		
65	—	—	—		
66	500 375 00	2	2	M 8 x 20	DIN 835-5.8

**M 04**

Nockenwelle  
Camshaft  
Arbre à cames  
Arbol de levas

**M 09**

Stoßstangen  
Pushrod  
Tige de culbut.  
Varilla de balancin

**M 10**

Ölpumpe  
Oil pump  
Pompe à huile  
Bomba de aceite

**M 11**

Steuergehäuse  
Gov. housing  
Carter distrib.  
Caja de mando

Tafel Nr.  
Tabl. No.

07

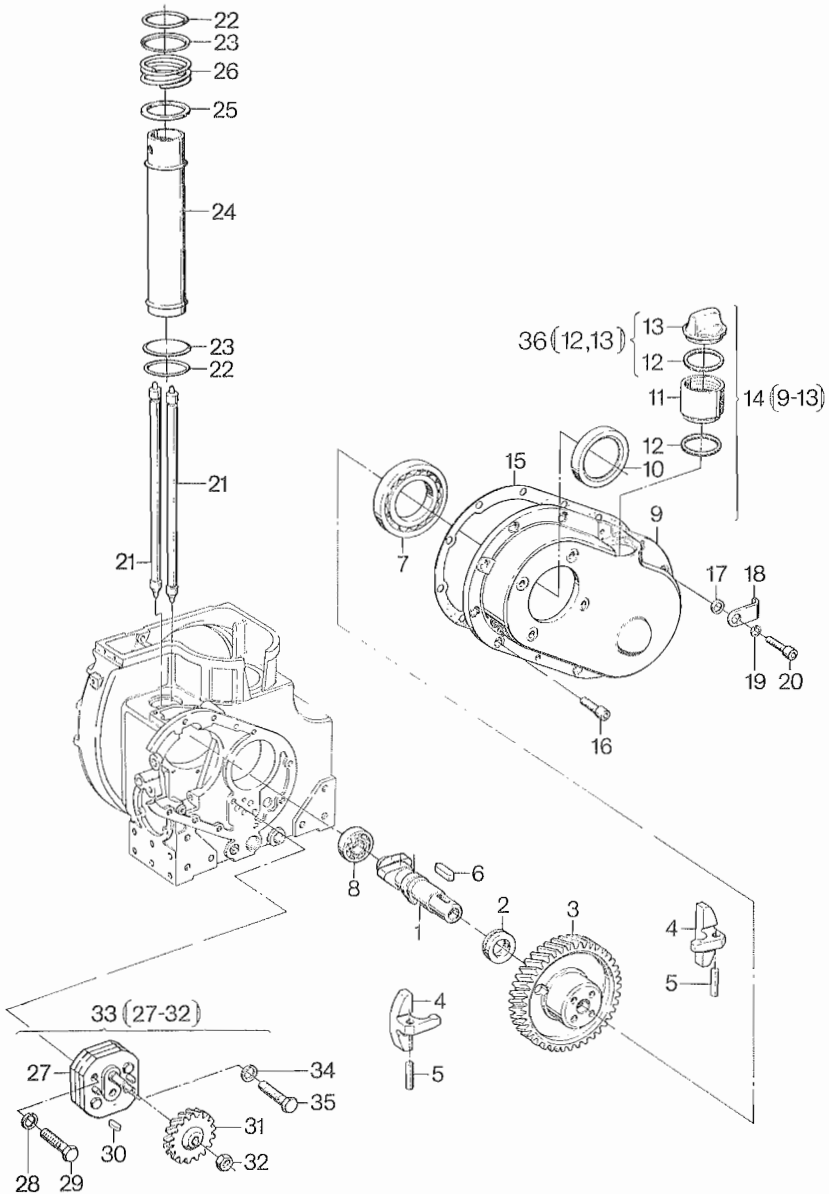



Fig. No.	Bestell-Nr. Ordering No. No. référence No. de pedido	Stück Quantity Quantités Cantidades		Hinweise Hints Indications Indicaciones	
		E 88	E 89		
1	030 376 11	1	1		
2	034 518 01	1	1		
3	030 274 03	1	1		
4	030 377 01	2	2		
5	031 569 00	2	2		
6	500 114 00	1	1	A 8 x 7 x 25	DIN 6885
7	500 155 00	1	1	16014	DIN 625
8	500 147 00	1	1	6304	DIN 625
9	—	—	—		
10	500 456 00 D1	1	1	70 x 85 x 8 BB	
11	036 566 00	1	1		
12	400 236 00 D1	2	2		
13	—	—	—		
14	003 285 00	1	1		
15	031 500 00 D1	1	1		
16	500 519 00	9	9	M 8 x 20	DIN 912-8.8
17	031 332 00	1	1		
18	031 592 00	1	1		
19	500 028 00	1	1	8	DIN 128
20	500 521 00	1	1	M 8 x 25	DIN 912-8.8
21	003 351 00	2	2		
22	400 235 00 d2	2	2	35 x 6	
23	031 599 00	2	2		
24	030 380 02	1	1		
25	031 601 00	1	1		
26	031 600 00	1	1		
27	—	—	—		
28	500 028 00	1	1	8	DIN 128
29	500 275 00	1	1	M 8 x 35	DIN 931-8.8
30	500 104 00	1	1	A 4 x 4 x 10	DIN 6885
31	030 278 02	1	1	15°	
32	400 284 00	1	1	M 8	SSN 440-8 Cu
33	004 292 02	1	1		
34	500 028 00	1	1	8	DIN 128
35	500 275 00	1	1	M 8 x 35	DIN 931-8.8
36	005 623 00	1	1		

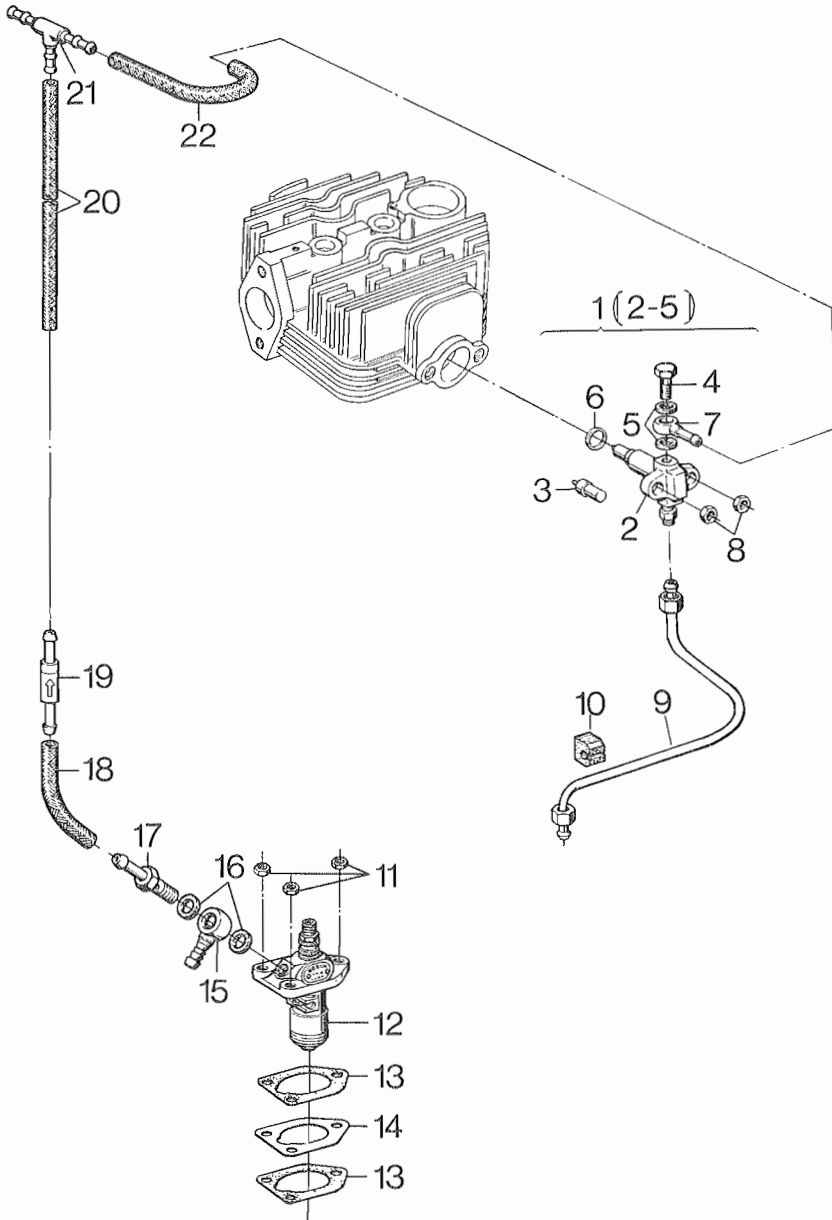

Fig. No.	Bestell-Nr. Ordering No. No. référence No. de pedido	Stück Quantity Quantités Cantidades		Hinweise Hints Indications Indicaciones	
		E 88	E 89		
1	400 063 02	1	1		
2	—	—	—		
3	400 045 01 P1	1	1		
4	500 061 00	1	1	A 2/3	DIN 7623
5	500 009 00 d2	2	2	A 8 x 11,5	DIN 7603-Cu
6	031 605 00 d1	1	1		
7	500 157 00	1	1		
8	500 229 00	2	2	M 8	DIN 934-8
9	003 354 01	1	1		
10	031 509 00	1	1		
11	500 229 00	3	3	M 8	DIN 934-8
12	400 053 01	1	1		
13	031 684 00 D2	2	2		
14	031 683 02	0 ... 2	0 ... 2	0,15 mm	
14	031 685 01	0 ... 2	0 ... 2	0,20 mm	
14	031 686 01	0 ... 2	0 ... 2	0,25 mm	
14	031 687 01	1	1	0,30 mm	
15	500 158 00	1	1		
16	500 011 00 D2	2	2	A 12 x 15,5	DIN 7603-Cu
17	036 623 00	1	1		
18	036 637 00	1	1	4,5 x 2,5 - 50 mm	
19	008 055 00 P1	1	1		
20	038 070 00	1	1	4,5 x 2,5 - 410 mm	
21	501 578 00	1	1		
22	036 642 00	1	1	4,5 x 2,5 - 130 mm	

**M 17**

Schwungräder  
Flywheels  
Volants  
Volantes

**M 26**

Luftführung  
Air ducting  
Carter ventilation  
Conduccion de aire

Tafel Nr.  
Tabl. No.

09

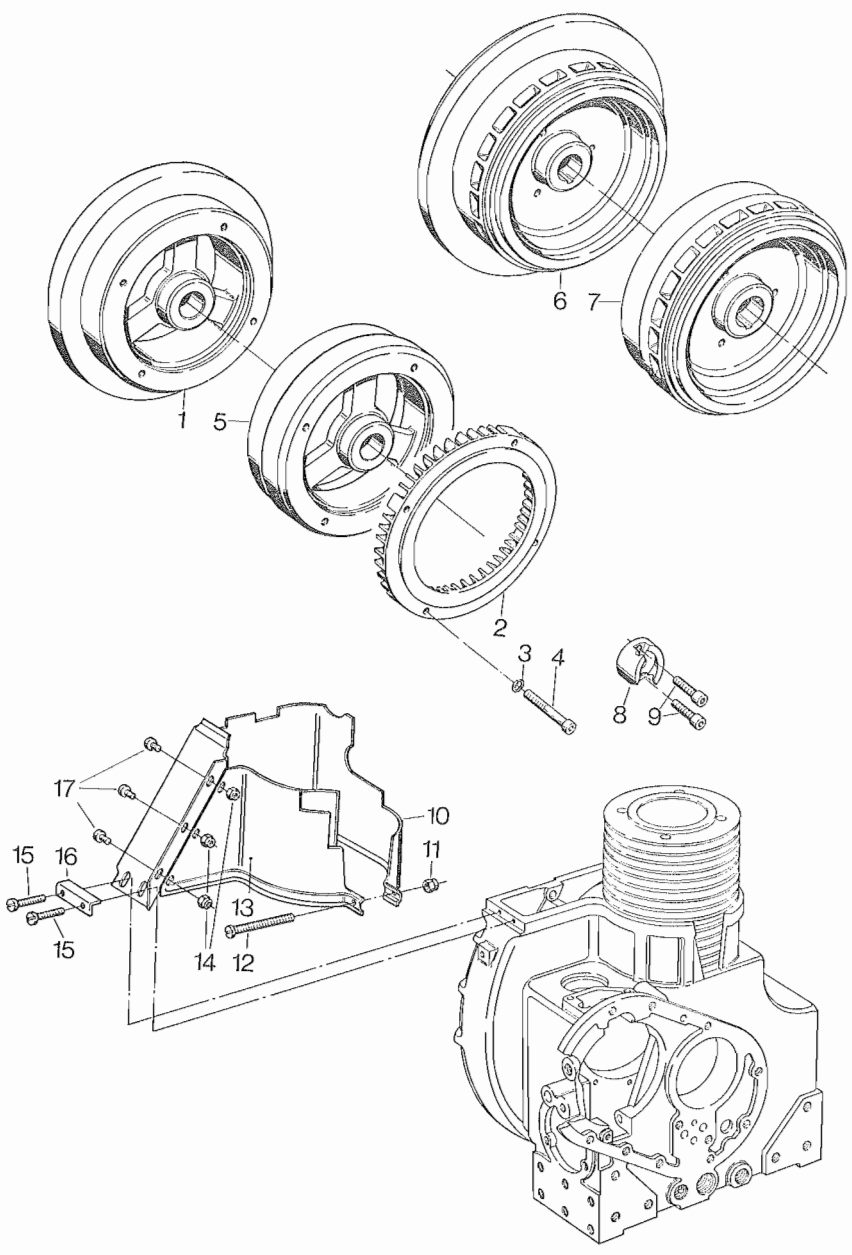

Fig. No.	Bestell-Nr. Ordering No. No. référence No. de pedido	Stück Quantity Quantités Cantidades		Hinweise Hints Indications Indicaciones	
		E 88	E 89		
1	030 325 00	1	—	„G“	
2	030 303 00	1	—		
3	500 028 00	4	—	8	DIN 128
4	500 527 00	4	—	M 8 x 50	DIN 912-8.8
5	030 324 00	1	—	„FG“	
6	030 382 01	—	1	„G“	
7	030 381 01	—	1	„FG“	
8	030 249 01	1	1		
9	500 538 00	2	2	M 10 x 25	DIN 912-8.8
10	030 366 01	1	1		
11	400 282 00	1	1		
12	500 499 00	1	1		
13	030 365 01	1	1		
14	400 282 00	3	3	M 5	SSN 440-8 Cu
15	500 494 00	2	2	M 5 x 20	DIN 84-4.8
16	034 492 00	1	1		
17	500 059 00	3	3	AM 5 x 8	DIN 84-4.8

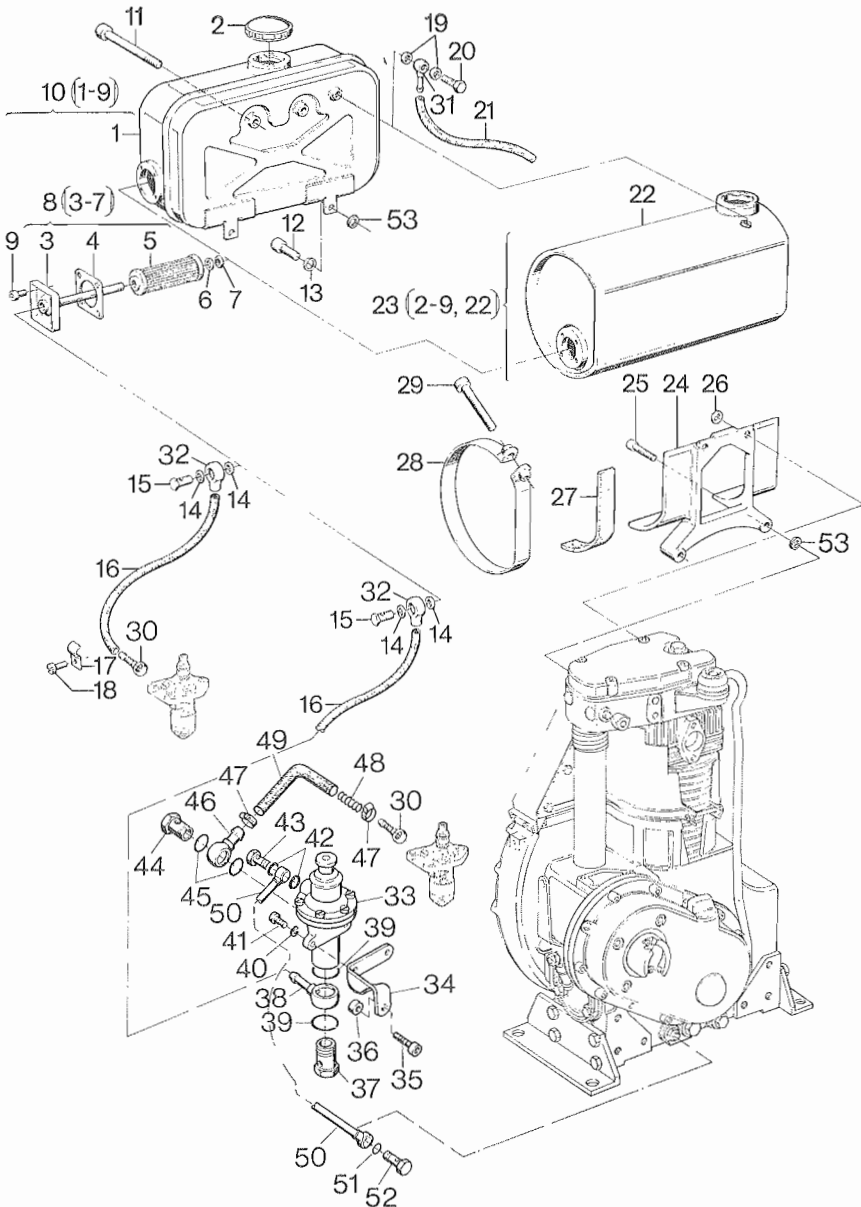

Fig. No.	Bestell-Nr.	Stück	Hinweise	
	Ordering No.	Quantity	Hints	
	No. référence	Quantités	Indications	
	No. de pedido	Cantidades	Indicaciones	
		E 88	E 89	
1	—	—	—	
2	400 327 00 P1	1	1	
3	—	—	—	
4	031 502 02 W2, D1	1	1	
5	400 438 00 W2	1	1	
6	031 506 00 W1	1	1	
7	400 835 00 W1	1	1	
8	003 291 02	1	1	
9	500 627 00 W4	4	4	M 6 x 10      DIN 912-8.8
10	004 118 01	1	1	7 Ltr.
11	500 559 00	2	2	M 10 x 120      DIN 912-8.8
12	500 538 00	2	2	M 10 x 25      DIN 912-8.8
13	500 029 00	2	2	10      DIN 128
14	500 012 00 W4, D2	2	2	A 14 x 18      DIN 7603-Cu
15	500 064 00	1	1	A8      DIN 7623
16	036 934 00	1	1	7,0 x 2,5 — 360 mm
16	036 743 00	1	1	7,0 x 2,5 - 305 mm
17	500 003 00	1	1	BSN 12      DIN 1592
18	502 892 00	1	1	M 6 x 12      DIN 8.8 A3D
19	500 009 00 D5	2	2	A 8 x 11,5      DIN 7603-Cu
20	500 061 00	1	1	A 2/3      DIN 7623
21	036 637 00	1	1	4,5 x 2,5 - 50 mm (7 Ltr.)
21	036 643 00	1	1	4,5 x 2,5 - 75 mm (11,5 Ltr.)
22	—	—	—	
23	003 064 01	1	1	11,5 Ltr.
24	033 782 01	1	1	
25	500 550 00	2	2	M 10 x 50      DIN 912-10.9
26	500 617 00	2	2	A 10      DIN 137
27	034 925 00	4	4	
28	007 786 00	4	4	
29	035 377 00	4	4	
30	500 158 00	1	1	
31	500 157 00	1	1	
32	500 159 00	1	1	
33	008 401 00	1	1	
34	038 033 00	1	1	

**A 01**

Kraftstoffbehälter, Absperrventil, Leitungen  
Fuel tank, shut off valve, pipes  
Reservoir à carburant, soupape d'arrêt, filtre conduites  
Depósito combustible, valvula de parada, filtro tubería

Tafel Nr.  
Tabl. No.

10

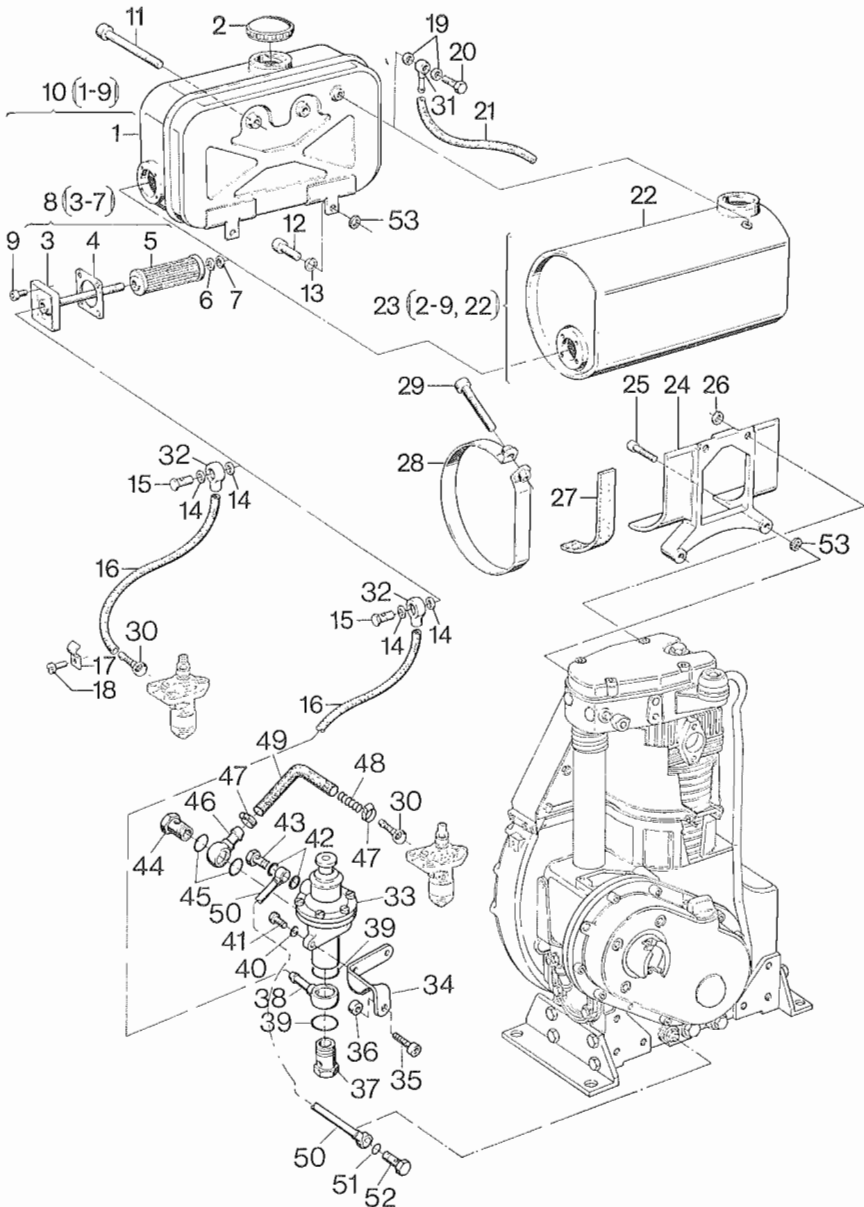



Fig. No.	Bestell-Nr. Ordering No. No. référence No. de pedido	Stück Quantity Quantités Cantidades		Hinweise Hints Indications Indicaciones	
		E 88	E 89		
35	500 522 00	1	1	M 8 x 30	DIN 912-8,8
36	036 516 00	1	1		
37	500 064 00	1	1	10 - 3	DIN 7643
38	500 159 00	1	1		
39	500 012 00 D2	2	2	A 14 x 16	DIN 7603-Cu
40	500 026 00	2	2	5	DIN 128
41	501 109 00	2	2	M 5 x 16	DIN 84-4.8
42	500 009 00 D5	2	2	A 8 x 11,5	DIN 7603-Cu
43	500 061 00	1	1	4 - 5 - 3	DIN 7643
44	500 063 00	1	1	8 - 3	DIN 7643
45	500 011 00 D2	2	2	A 12 x 15,5	DIN 7603-Cu
46	500 158 00	1	1		
47	400 373 00	2	2	8 - 12	
48	038 125 00	1	1		
49	038 034 00	1	1		
50	010 027 01	1	1		
51	500 624 00	1	1	A 10 x 13,5	DIN 7603-Cu
52	500 062 00	1	1	6 - 3	DIN 7643
53	500 706 00	2	2	10,5	DIN 7349-A3C

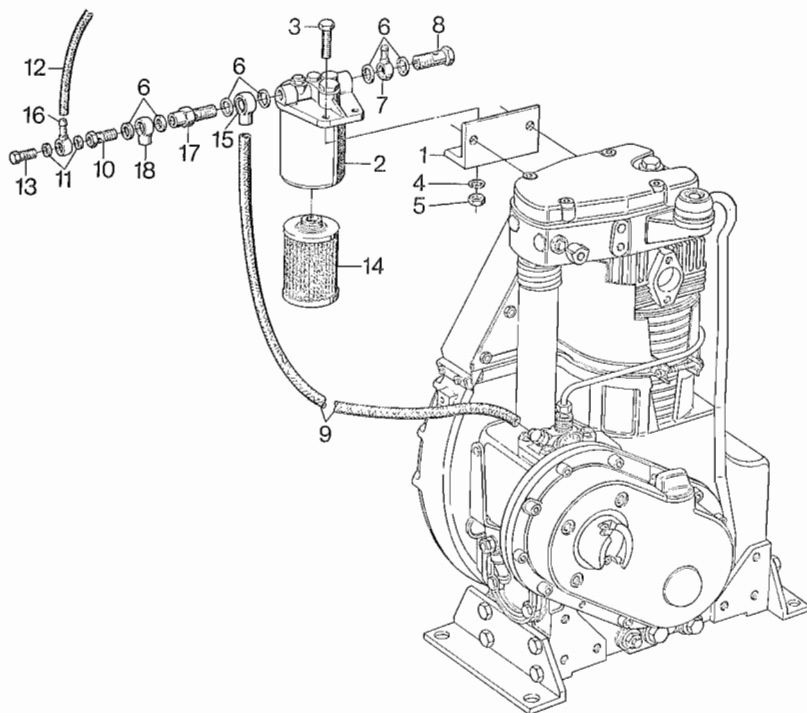

Fig. No.	Bestell-Nr. Ordering No. No. référence No. de pedido	Stück Quantity Quantités Cantidades		Hinweise Hints Indications Indicaciones	
		E 88	E 89		
1	035 240 00	1	1		
2	400 674 00	1	1		
3	500 293 00	2	2	M 10 x 30	DIN 933-8.8
4	500 029 00	2	2	10	DIN 128
5	500 235 00	2	2	M 10	DIN 934-8
6	500 012 00	6	6	A 14 x 18	DIN 7603-Cu
7	500 159 00	1	1		
8	500 064 00	1	1	A 8	DIN 7623
9	036 734 00	1	1	7,0 x 2,5 - 510 mm	
10	032 807 00	1	1		
11	500 009 00 D5	2	2	A 8 x 11,5	DIN 7603-Cu
12	036 637 00	1	1	4,5 x 2,5 - 50 mm	
13	500 061 00	1	1	A 2/3	DIN 7623
14	400 073 00	1	1		
15	500 160 00	1	1		
16	500 157 00	1	1		
17	034 977 00	1	1		
18	501 517 00	1	1		

**A 02**

Luftfilter  
Air filter  
Filtre à air  
Filtro de aire

Tafel Nr.  
Tabl. No.

12

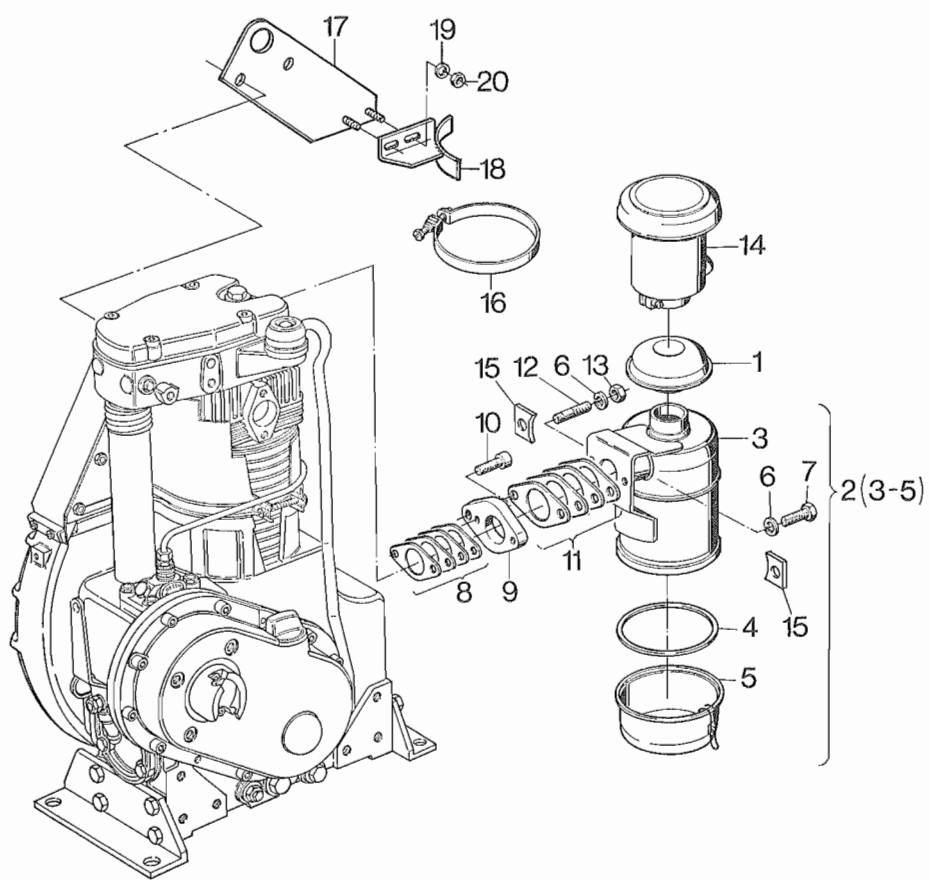

Fig. No.	Bestell-Nr. Ordering No. No. référence No. de pedido	Stück Quantity Quantités Cantidades		Hinweise Hints Indications Indicaciones	
		E 88	E 89		
1	400 367 00 P1	1	1	62 mm $\phi$	
2	010 785 00	1	1		
3	—	—	—		
4	490 380 00 P1	1	1		
5	490 566 00	1	1		
6	501 356 00	2	2	10	DIN 128-A3C
7	501 499 00	1	1	M 10 x 30	DIN 933.8.8 A3C
8	012 847 00 W2, d1	1	1		
9	030 400 00	1	1		
10	500 538 00	1	1	M 10 x 25	DIN 912-8.8
11	011 587 00 W2, d1	1	1		
12	500 415 00	1	1	M 10 x 50	DIN 938-5.8 A3C
13	501 458 00	1	1	M 10	DIN 934-8 A3C
14	011 194 00	1	1		
15	039 454 00	2	2		
16	400 296 00	1	1	145/20	
17	011 638 00	1	1		
18	011 639 00	1	1		
19	501 143 00	2	2	6,4	DIN 7349 Zn
20	501 444 00	2	2	M 6	DIN 934-8 A3C

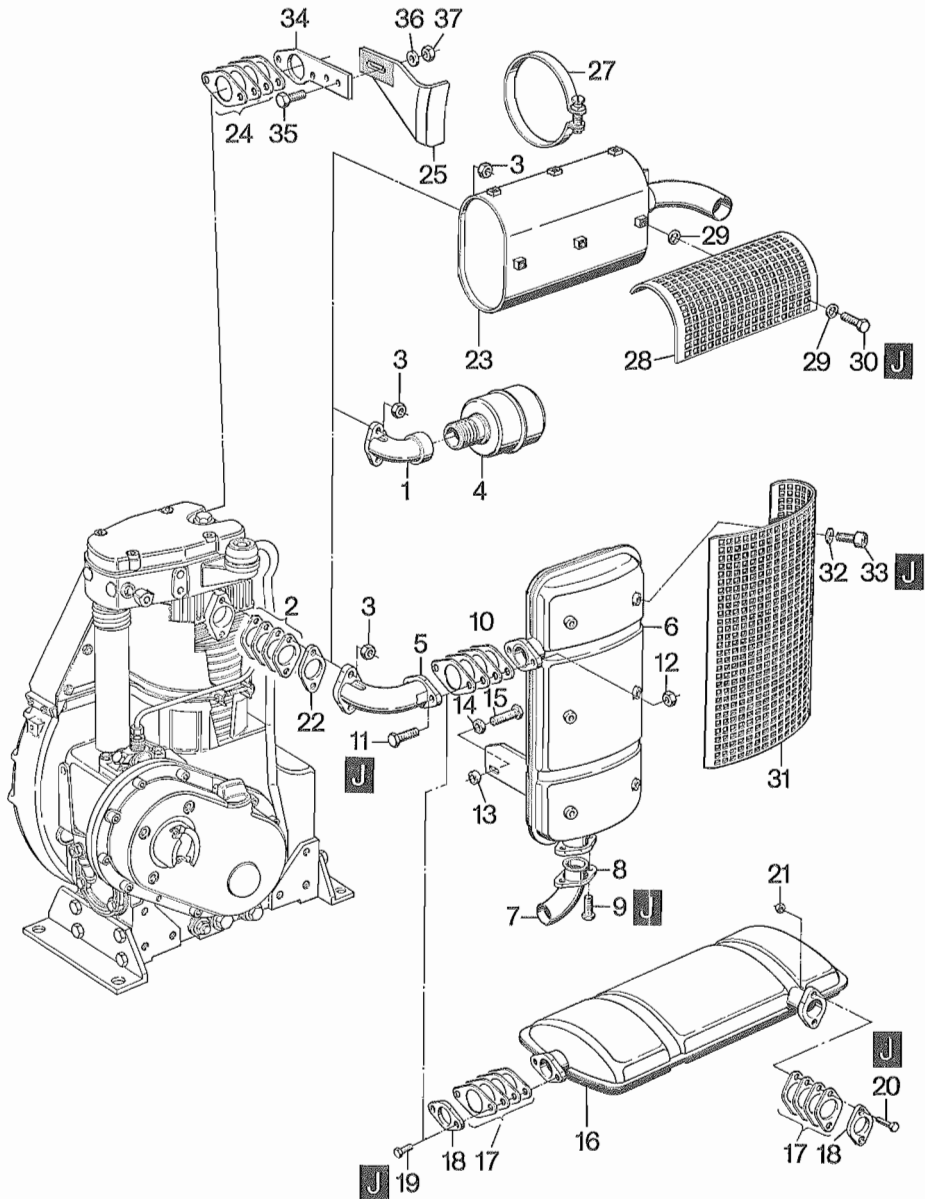

Fig. No.	Bestell-Nr. Ordering No. No. référence No. de pedido	Stück Quantity Quantités Cantidades		Hinweise Hints Indications Indicaciones	
		E 88	E 89		
1	030 342 00	1	1		
2	012 860 00 d1	1	1		
3	500 230 00	2	2	M 8 Ms	DIN 934-Ms
4	008 722 00	1	1		
5	031 023 00	1	1		
6	003 102 01	1	1		
7	031 763 00	1	1		
8	032 988 00	1	1		
9	500 268 00	2	2	M 8 x 30	DIN 933-8.8
10	012 860 00 d1	1	1		
11	500 273 00	2	2	M 8 x 30	DIN 933-8.8
12	500 230 00	2	2	M 8 Ms	DIN 934-Ms
13	037 141 00	2	2		
14	037 142 00	2	2		
15	501 759 00	2	2	M 8 x 30	DIN 912-8.8 A3C
16	008 618 00	1	1		
17	012 860 00 d1	2	2		
18	033 242 00	2	2		
19	500 268 00	2	2	M 8 x 20	DIN 933-8.8
20	500 270 00	2	2	M 8 x 25	DIN 933-8.8
21	500 230 00	2	2	M 8 Ms	DIN 934-Ms
22	033 242 00	1	1		
23	008 660 00	1	1		
24	012 847 00 W2, d1	1	1		
25	037 312 00	1	1		
26	—	—	—		
27	400 296 00	1	1		
28	035 456 00	1	1		
29	500 168 00	12	12	8,4 Ms	DIN 125-Ms
30	501 731 00	6	6	M 8 x 10	DIN 912-8.8 Zn
31	037 294 00	1	1		
32	501 200 00	7	7	A 6,4	DIN 9021-St Zn
33	501 390 00	7	7	M 6 x 10	DIN 912-8.8 C4P
34	035 335 10	1	1		
35	501 354 00	2	2	M 8 x 20	DIN 933-8.8 A3C
36	501 481 00	2	2	8,4	DIN 125 St A3C
37	501 480 00	2	2	M 8	DIN 934-8 A3C

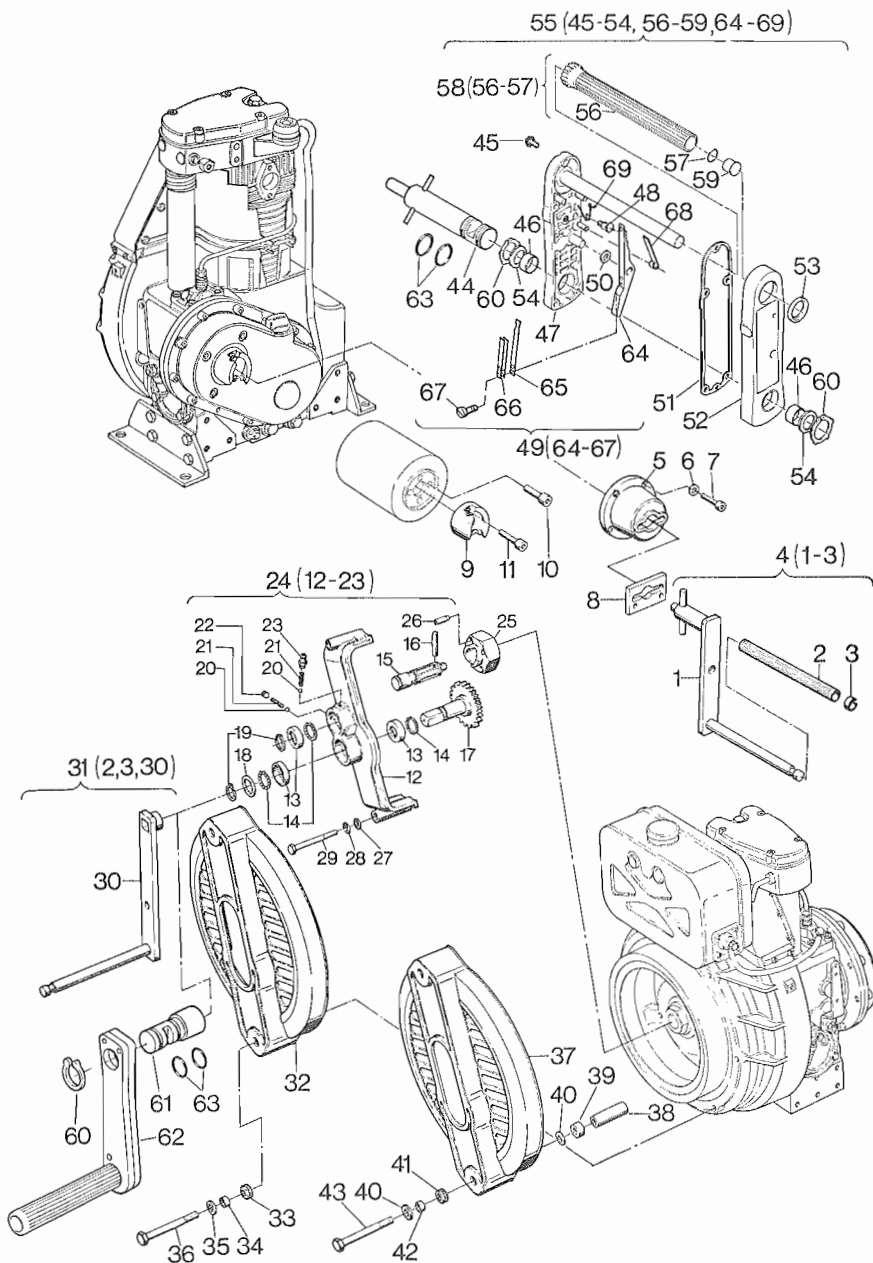



Fig. No.	Bestell-Nr.	Stück		Hinweise	
	Ordering No.	Quantity	Quantités	Hints	
	No. référence	Quantités	Cantidades	Indications	
	No. de pedido	Cantidades		Indicaciones	
		E 88	E 89		
1	—	—	—		
2	035 224 00	1	1		
3	035 154 00	1	1		
4	003 023 02	1	1	25 mm	
4	003 028 03	1	1	82 mm	
4	003 050 00	1	1	125 mm	
4	003 025 02	1	1	184 mm	
4	003 049 00	1	1	265 mm	
4	004 912 00	1	1	422 mm	
5	030 811 01	1	1		
6	501 481 00	4	4	8,4	DIN 125-St A3C
7	501 715 00	4	4	M 8 x 25	DIN 912-8.8 A3C
8	030 266 00	1	1		
9	030 250 00	1	1		
10	500 538 00	2	2	M 10 x 25	DIN 912-8.8
11	500 541 00	2	2	M 10 x 30	DIN 912-8.8
12	—	—	—		
13	031 753 01	3	3		
14	500 098 00	45	45	6 mm III	DIN 5401
15	030 085 00	1	1		
16	500 095 00	1	1	8 x 45	DIN 1475
17	030 113 00	1	1		
18	030 124 01	1	1		
19	500 204 00	2	2	24 x 1,2	DIN 471
20	500 098 00	2	2	6 mm III	DIN 5401
21	031 591 00	2	2		
22	030 794 00	1	1		
23	500 078 00	1	1	AM 8 x 1	DIN 71412
24	003 356 02	1	1	„FG“	
25	030 374 00	1	1		
26	500 051 00	1	1	AM 10 x 25	DIN 915-45 H
27	500 170 00	2	2	10,5	DIN 433-St
28	500 029 00	2	2	10	DIN 128
29	500 304 00	2	2	M 10 x 90	DIN 931-8.8
30	—	—	—		
31	003 030 02	1	1		
32	035 137 00	1	1	„FG“	
33	036 652 00	6	6		
34	035 147 00	2	2		

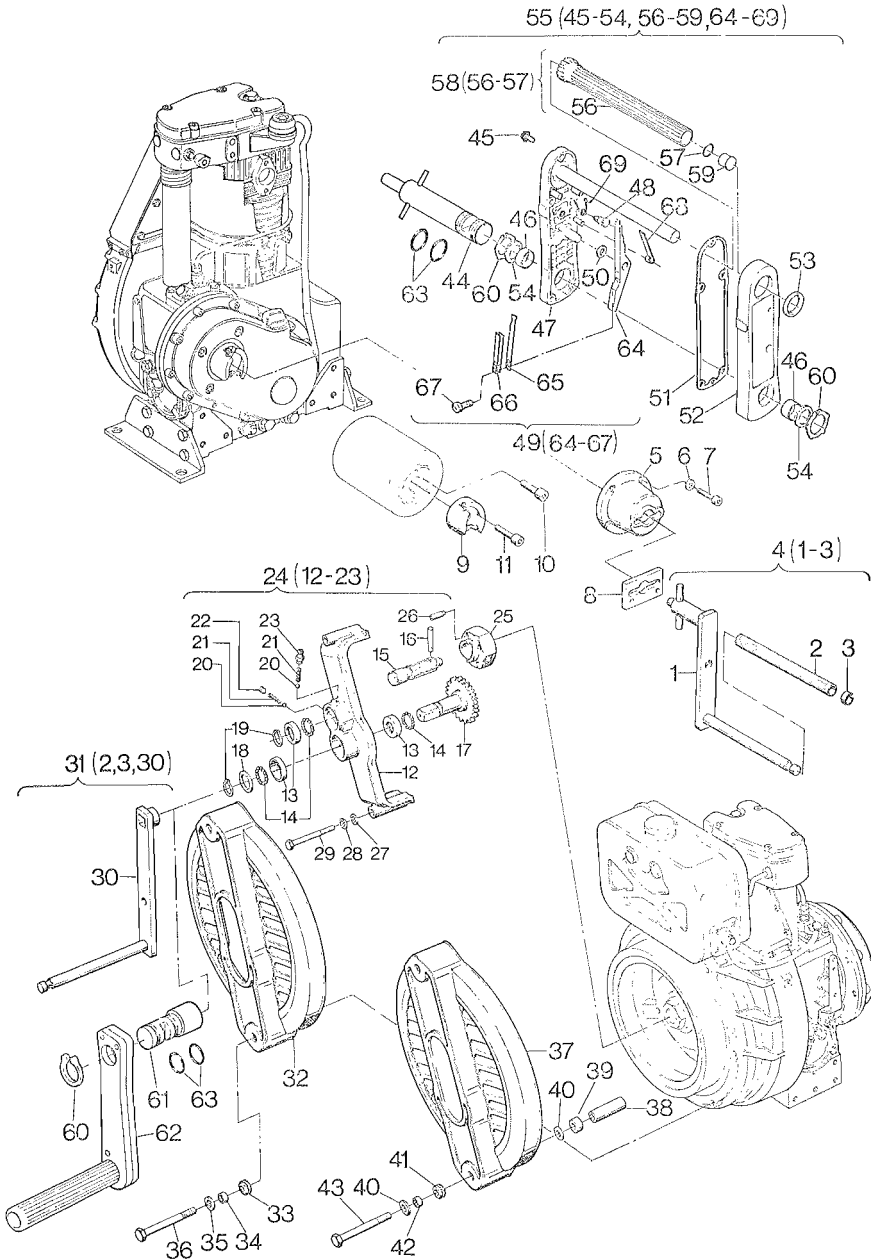

Fig. No.	Bestell-Nr. Ordering No. No. référence No. de pedido	Stück Quantity Quantités Cantidades		Hinweise Hints Indications Indicaciones	
		E 88	E 89		
35	500 170 00	2	2	10,5	DIN 433-St
36	500 305 00	2	2	M 10 x 100	DIN 931-8.8
37	035 138 00	1	1	„FG“	
38	031 233 00	2	2		
39	033 006 00	2	2		
40	501 459 00	4	4	B 10,5	DIN 125-StA3C
41	036 652 00	6	6		
42	035 147 00	2	2		
43	500 305 00	2	2	M 10 x 100	DIN 931-8.8
44	010 190 00	1	1	82 mm	
44	010 191 00	1	1	125 mm	
44	010 192 00	1	1	184 mm	
44	010 193 00	1	1	265 mm	
44	010 194 00	1	1	422 mm	
45	501 944 00	5	5	M 6 x 25	DIN 6912-8.8 A3C
46	501 934 00	2	2		
47	—	—	—		
48	039 556 00	1	1		
49	010 114 04	1	1		
50	501 958 00	1	1	10 x 16 x 0,5	DIN 988
51	038 130 00	1	1		
52	—	—	—		
53	501 942 00	1	1		
54	039 286 00	0 ... 4	0 ... 4		
55	010 278 05	1	1	„A“	
56	—	—	—		
57	501 691 00	1	1	19 x 1,8	DIN 769
58	010 113 10	1	1		
59	501 992 00	1	1		
60	501 943 00	2	2	A 30 x 1,5 K	DIN 983
61	010 189 00	1	1		
62	010 279 05	1	1	„B“	
63	502 585 00	2	2	26 x 1,5	
64	—	—	—		
65	038 121 02	1	1		
66	039 171 00	2	2		
67	503 165 00	2	2	M 5 x 8	DIN 6912-8.8
68	039 549 00	1	1		
69	039 559 00	1	1	„A“	
69	039 560 00	1	1	„B“	

**A 04, 12**

Andrehkurbel, Keilriemenschutz  
Starting handle, v-belt guard  
Manivelle, protection courroie  
Manivela, revestimiento

Tafel Nr.  
Tabl. No.

15

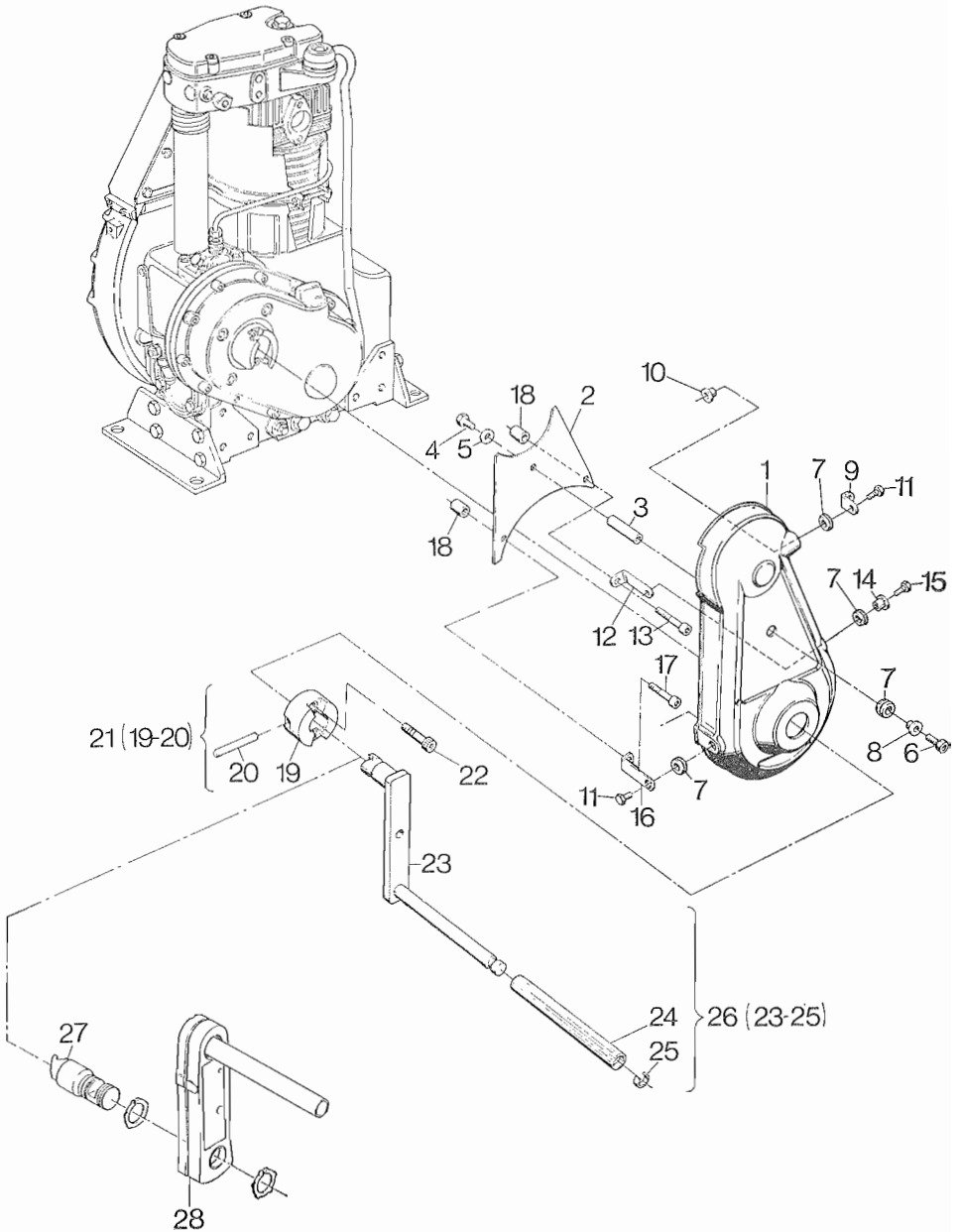

Fig. No.	Bestell-Nr. Ordering No. No. référence No. de pedido	Stück Quantity Quantités Cantidades		Hinweise Hints Indications Indicaciones	
		E 88	E 89		
1	035 441 00	1	1		
2	035 440 00	1	1		
3	036 852 00	1	1		
4	500 267 00	1	1	M 8 x 16	DIN 933-8.8
5	501 481 00	2	2	8,4	DIN 125-StA3C
6	502 063 00	1	1	M 8 x 18	DIN 912-8.8 A3C
7	036 652 00	4	4		
8	035 283 00	1	1		
9	035 439 00	1	1		
10	035 359 00	2	2		
11	501 491 00	2	2	M 6 x 12	DIN 912-8.8 A3C
12	036 771 00	1	1		
13	500 527 00	1	1	M 8 x 50	DIN 912-8.8
14	033 776 00	1	1		
15	501 707 00	1	1	M 6 x 16	DIN 912-8.8 A3C
16	033 856 00	1	1		
17	500 526 00	1	1	M 8 x 45	DIN 912-8.8
18	033 695 00	2	2		
19	—	—	—		
20	030 126 00	1	1		
21	008 021 00	1	1		
22	500 550 00	2	2	M 10 x 50	DIN 912-10.9
23	—	—	—		
24	035 224 00	1	1		
25	035 154 00	1	1		
26	003 019 02	1	1		
27	010 195 00	1	1	50 mm	
28	010 278 05	1	1	„A“	

A 04

Dekompression  
Decompression  
Décompression  
Decompresión

A 07

Öleinfüllung  
Oil filling  
Remplissage huile  
Tubuladura

Tafel Nr.  
Tabl. No.

16

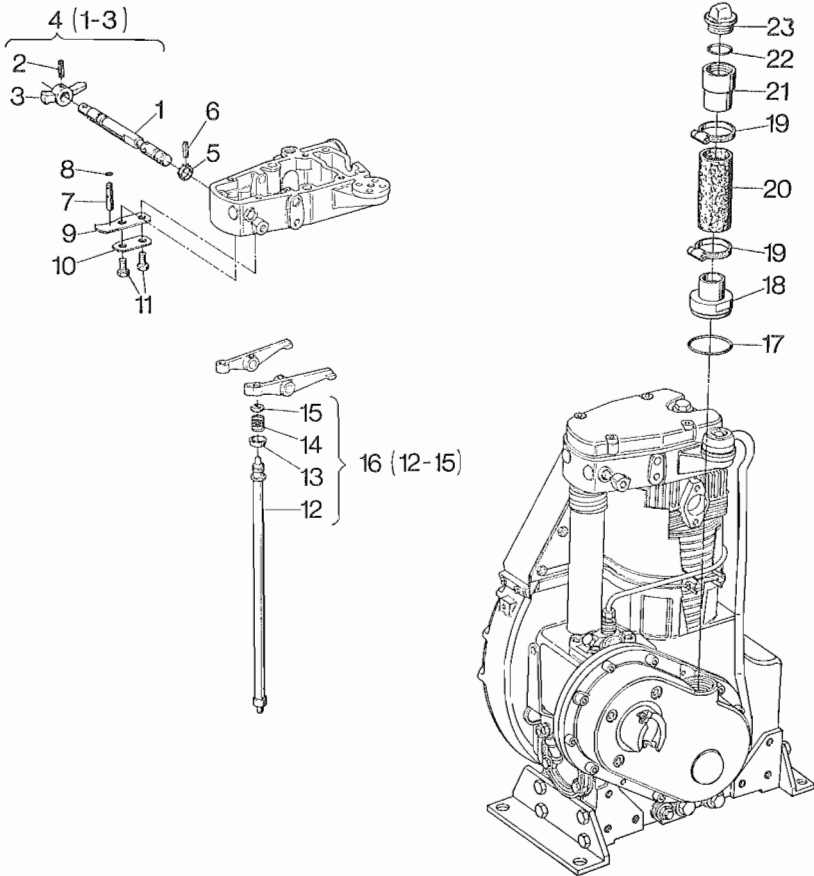

Fig. No.	Bestell-Nr.	Stück	Hinweise	
	Ordering No.	Quantity	Hints	
	No. référence	Quantités	Indications	
	No. de pedido	Cantidades	Indicaciones	
		E 88	E 89	
1	—	—	—	
2	500 346 00	1	1	4 x 18
3	031 734 01	1	1	DIN 1481
4	003 283 00	1	1	
5	030 276 00	1	1	
6	500 341 00	1	1	3 x 16
7	030 264 00	1	1	DIN 1481
8	400 216 00 d2	2	2	
9	031 512 00	1	1	
10	031 513 00	1	1	
11	500 255 00	2	2	M 6 x 12
12	—	—	—	DIN 933-8.8
13	030 004 01	1	1	
14	031 744 02	1	1	
15	400 309 00	1	1	
16	003 352 00	1	1	
17	400 236 00 D1	1	1	36 x 4
18	035 193 00	1	1	
19	400 865 00	2	2	
20	035 195 00	1	1	
21	034 730 00	1	1	
22	501 538 00	1	1	
23	030 690 04	1	1	

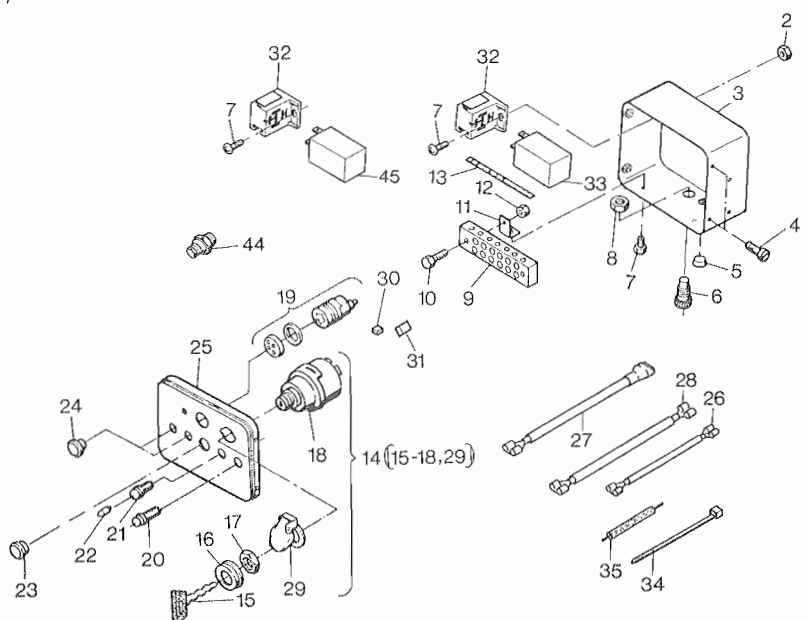
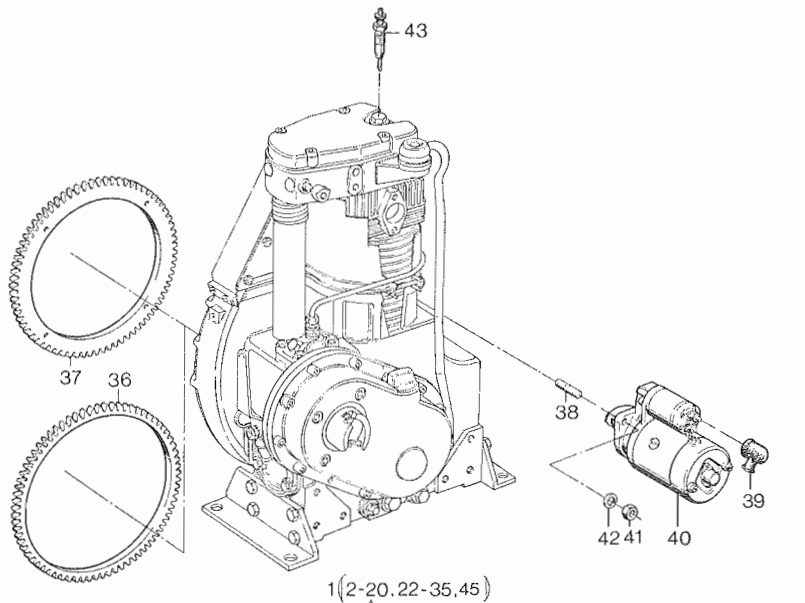



Fig. No.	Bestell-Nr. Ordering No. No. référence No. de pedido	Stück Quantity Quantités Cantidades		Hinweise Hints Indications Indicaciones	
		E 88	E 89		
1	003 329 22	1	1		
2	400 282 00	2	2	M 5	
3	007 163 11	1	1		
4	502 892 00	4	4	M 6 x 12	
5	501 608 00	2	2		
6	501 590 10	1	1		
7	500 493 00	4	4	M 5 x 10	DIN 7985-4.8 A3R
8	501 591 00	1	1		
9	501 607 00	1	1		
10	501 588 00	2	2	M 4 x 20	DIN 84.4.8 A3C
11	036 667 00	2	2		
12	501 471 00	2	2	M 4	DIN 934-8 A3C
13	—	—	—		
14	502 765 01	1	1		
15	503 453 00 P1	1	1		
16	—	—	—		
17	—	—	—		
18	—	—	—		
19	400 109 00	1	1		
20	501 765 00	1	1		BATT
21	501 766 00	1	1		OIL
22	400 097 00	1	1		12V 2W
23	400 914 00	1	1		F 24
24	400 960 00	3	3		F 17
25	035 092 11	1	1		
26	008 182 03	1	1		
27	010 898 01	1	1		
28	010 899 01	1	1		
29	490 509 00	1	1		
30	502 766 00	1	1		4 - P
31	502 767 00	1	1		6 - P
32	502 760 00	2	2		
33	502 758 01	1	1		12V HATZ
34	503 584 00	1	1		
35	503 444 00	1	1		
36	031 561 01	—	1		

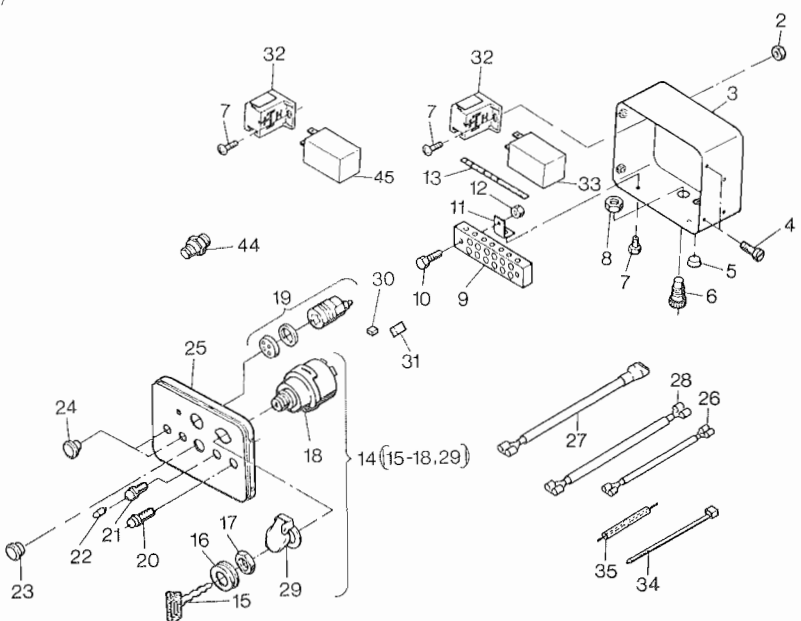
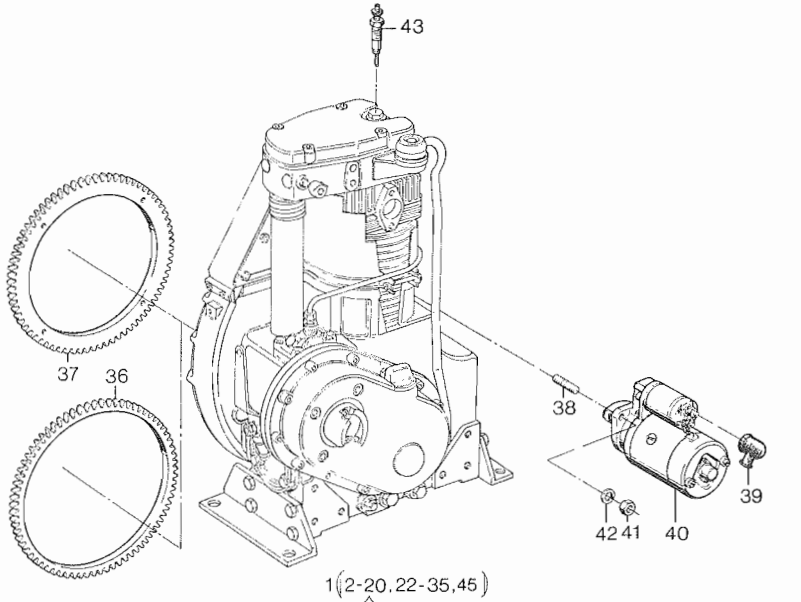

Fig. No.	Bestell-Nr. Ordering No. No. référence No. de pedido	Stück Quantity Quantités Cantidades		Hinweise Hints Indications Indicaciones	
		E 88	E 89		
37	031 561 00	1	—		
38	500 421 00	2	2	M 12 x 22	DIN 835-5.6
39	400 266 00	1	1		
40	400 004 00	1	1	12 V - 1,2 kW	
41	500 936 00	2	2	M 12	DIN 934-8 A3C
42	500 632 00	2	2	12	DIN 128 A3C
43	400 102 00	1	1		
44	400 213 00	1	1	12 V - 24 V	
45	502 777 01	1	1	12 V	

**A 05**

Generator  
Alternator  
Alternateur  
Alternador

Tafel Nr.  
Tabl. No.

18

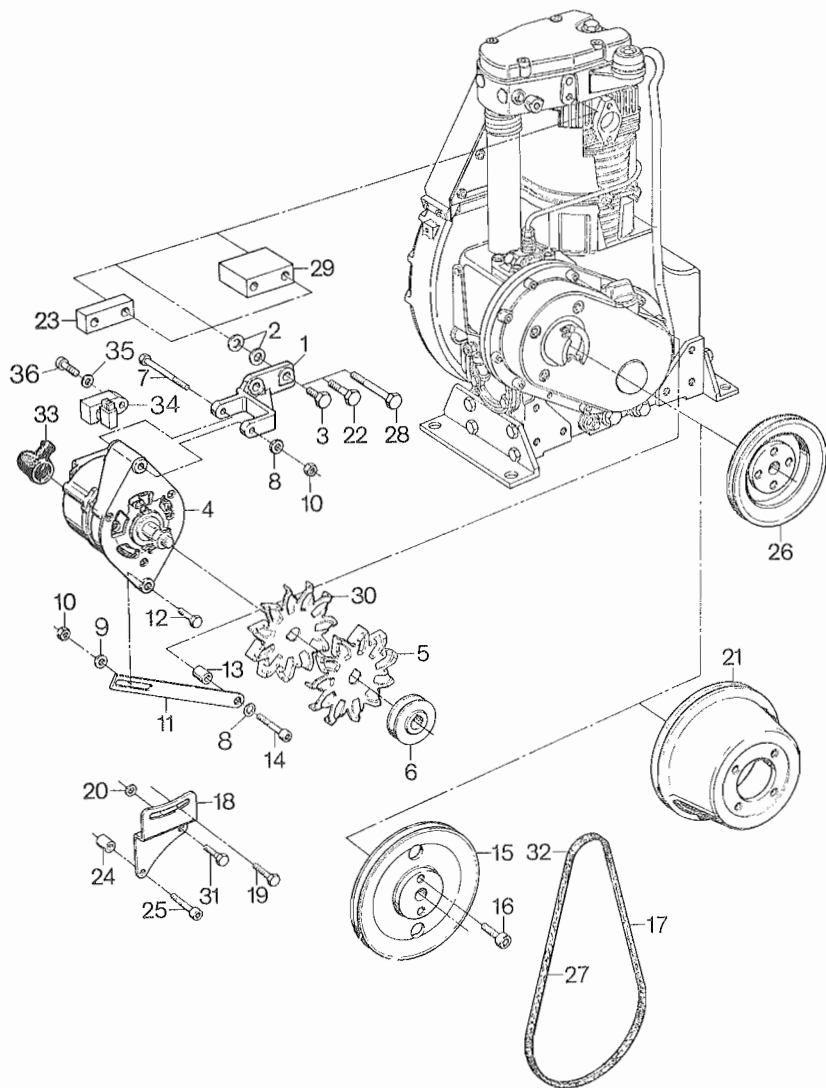

Fig. No.	Bestell-Nr. Ordering No. No. référence No. de pedido	Stück Quantity Quantités Cantidades		Hinweise Hints Indications Indicaciones	
		E 88	E 89		
1	035 112 01	1	1		
2	501 459 00	4	4	B 10,5	DIN 125-StA3C
3	500 293 00	2	2	M 10 x 30	DIN 933-8.8
4	400 993 00	1	1		
5	400 992 00	1	1		
6	035 114 00	1	1		
7	501 831 00	1	1	M 8 x 90	DIN 912-8.8 A3C
8	501 481 00	2	2	8,4	DIN 125-St A3C
9	037 142 00	2	2		
10	400 284 00	2	2	M 8	SSN 440-8 Cu
11	035 321 00	1	1		
12	501 830 00	1	1	M 8 x 35	DIN 912-8.8 A3C
13	033 695 00	1	1		
14	500 527 00	1	1	M 8 x 50	DIN 912.8.8
15	030 308 00	1	1		
16	500 544 00	2	2	M 10 x 35	DIN 912-8.8
17	501 368 00	1	1	10 x 875 mm	DIN 2215
18	035 202 00	1	1		
19	500 275 00	1	1	M 8 x 35	DIN 931-8.8
20	031 332 00	5	5		
21	030 310 00	1	1		
22	500 810 00	2	2	M 10 x 50	DIN 931-8.8
23	030 296 00	1	1		
24	035 206 00	2	2		
25	500 527 00	1	1	M 8 x 50	DIN 912-8.8
26	030 311 01	1	1		
27	501 251 00	1	1	10 x 800 mm	DIN 2215
28	500 304 00	2	2	M 10 x 90	DIN 931-8.8
29	035 222 00	1	1		
30	400 939 00	1	1		
31	501 830 00	1	1	M 8 x 35	DIN 912-8.8 A3C
32	501 235 00	1	1	10 x 1000 mm	DIN 2215
33	400 267 00	1	1		
34	490 374 00	1	1		
35	—	—	—		
36	—	—	—		

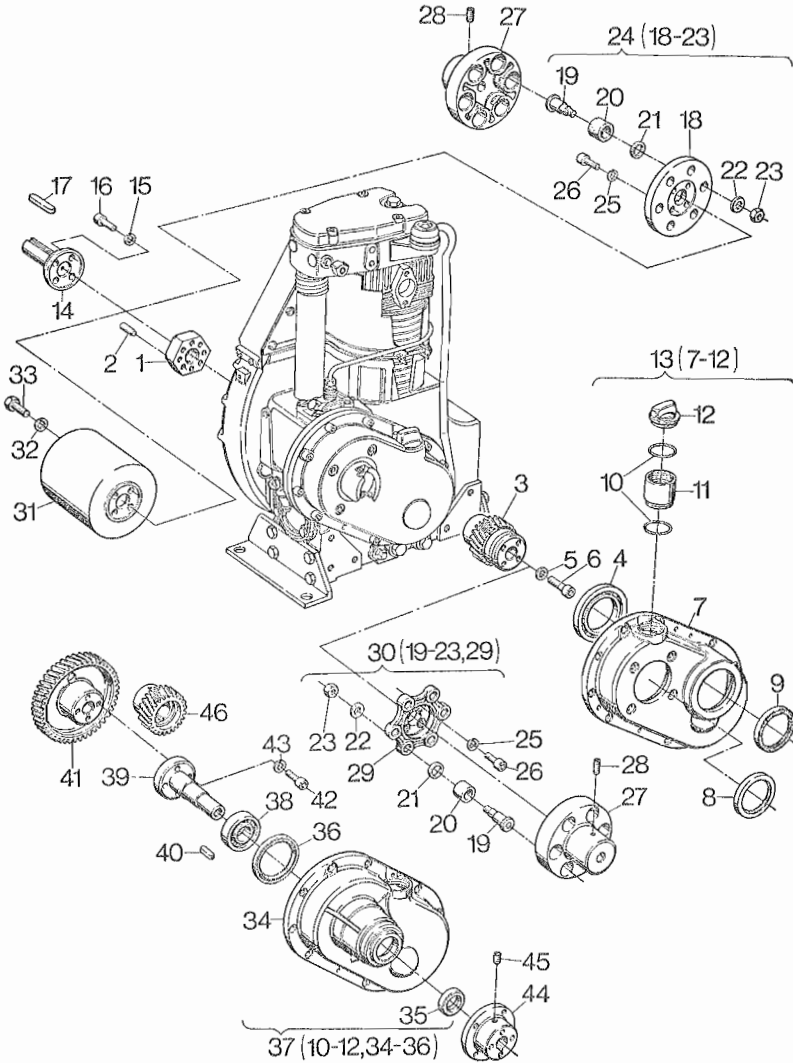

Fig. No.	Bestell-Nr. Ordering No. No. référence No. de pedido	Stück Quantity Quantités Cantidades		Hinweise Hints Indications Indicaciones	
		E 88	E 89		
1	030 260 00	1	1		
2	500 051 00	1	1	AM 10 x 25	DIN 915-45 H
3	030 284 01	1	1		
4	500 155 00	1	1	16014	DIN 625
5	400 332 00	1	1		
6	500 566 00	1	1	M 12 x 50	DIN 912-8.8
7	—	—	—		
8	500 456 00 D1	1	1	70 x 85 x 8 BB	
9	400 347 00	1	1		
10	400 236 00 D1	2	2		
11	036 566 00	1	1		
12	031 689 01	1	1		
13	003 298 00	1	1		
14	030 273 00	1	1		
15	501 356 00	4	4	10	DIN 128 A3C
16	500 538 00	4	4	M 10 x 25	DIN 912-8.8
17	500 117 00	1	1	A 8 x 7 x 63	DIN 6885
18	030 224 00	1	1		
19	003 072 00	6	6		
20	031 510 00	6	6		
21	030 790 00	6	6		
22	500 172 00	6	6	13	DIN 125-St
23	500 239 00	6	6	M 12	DIN 934-8
24	003 355 00	1	1		
25	500 029 00	4	4	10	DIN 128
26	500 538 00	4	4	M 10 x 25	DIN 912-8.8
27	030 358 00	1	1		
28	500 046 00	1	1	AM 8 x 15	DIN 916-45 H
29	030 042 01	1	1		
30	003 418 01	1	1		
31	030 255 01	1	1	125 $\phi$	
31	030 256 01	1	1	150 $\phi$	
31	030 257 01	1	1	175 $\phi$	
32	500 029 00	4	4	10	DIN 128
33	500 934 00	4	4	M 10 x 30	DIN 912-8.8
34	—	—	—		

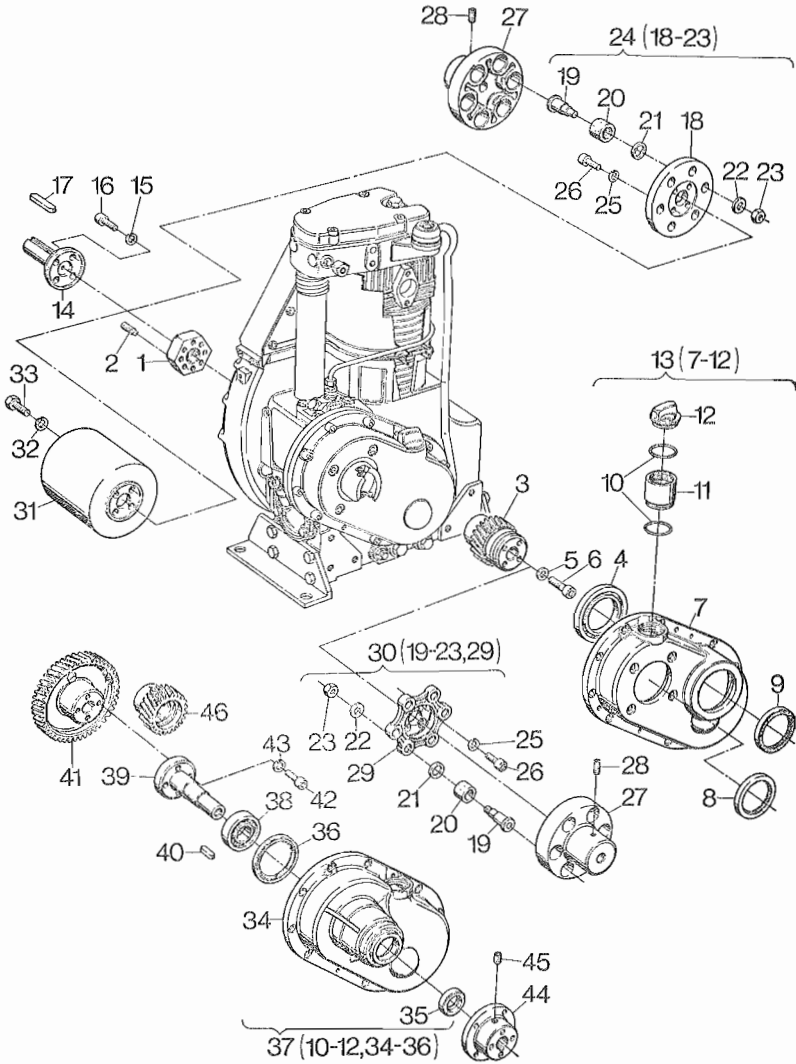



Fig. No.	Bestell-Nr. Ordering No. No. référence No. de pedido	Stück Quantity Quantités Cantidades		Hinweise Hints Indications Indicaciones	
		E 88	E 89		
35	500 451 00	1	1	30 x 50 x 12	
36	500 457 00	1	1	75 x 90 x 8	
37	005 622 00	1	1		
38	500 472 00	1	1	NJ 306	DIN 5412
39	030 228 00	1	1		
40	500 115 00	1	1	A 8 x 7 x 35	DIN 6885
41	030 394 02	1	1		
42	500 541 00	4	4	M 10 x 30	DIN 912-8.8
43	500 029 00	4	4	10	DIN 128
44	030 227 00	1	1		
45	500 048 00	1	1	AM 10 x 15	DIN 914-8.8
46	030 397 01	1	1		

A 17

Kupplung kurzaustrückbar  
Clutch short discon.  
Embrayage debr. cont.  
Embraque momentano

Tafel Nr.  
Tabl. No.

20

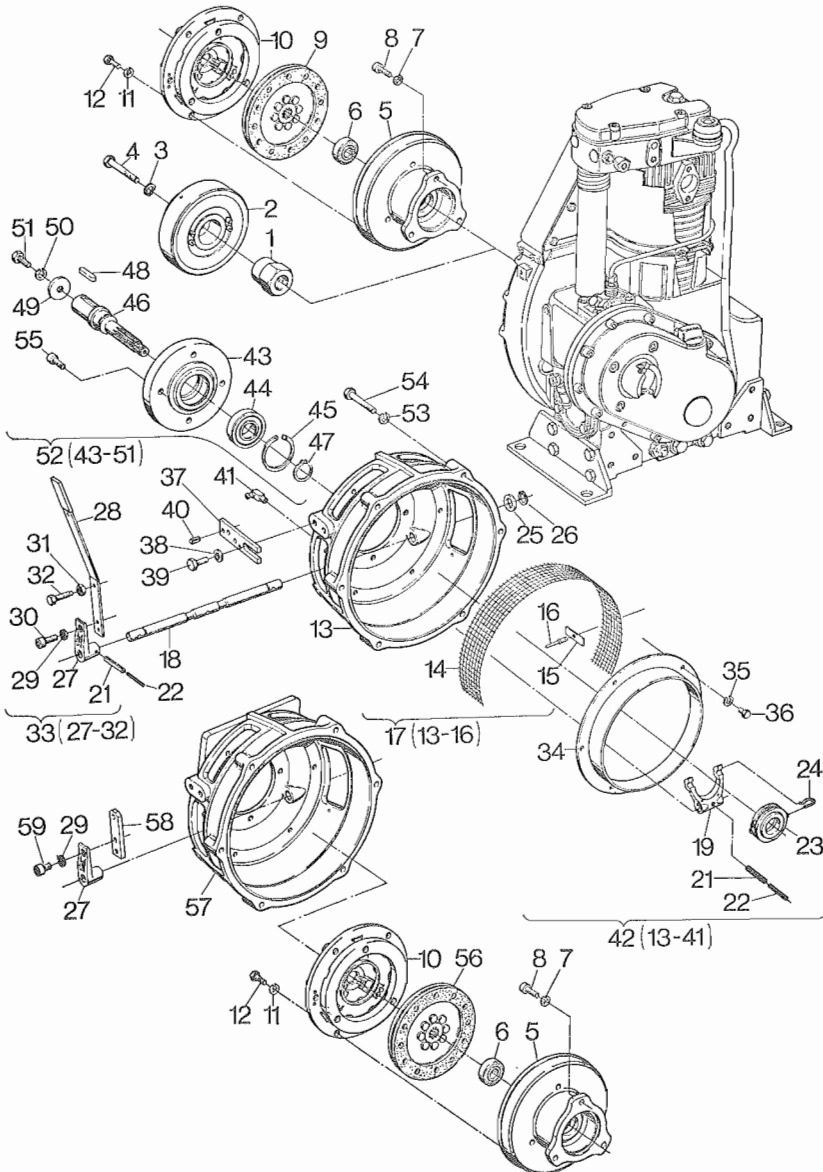

Fig. No.	Bestell-Nr. Ordering No. No. référence No. de pedido	Stück Quantity Quantités Cantidades		Hinweise Hints Indications Indicaciones	
		E 88	E 89		
1	030 252 00	1	1		
2	400 086 01	1	1		
2	400 088 00	1	1		
3	500 036 00	1	1	B 12	DIN 137
4	500 319 00	1	1	M 12x80	DIN 931-8.8
5	030 293 00	1	1	„FG“	
6	501 185 00	1	1	6204 2 RS C3	
7	500 029 00	3	3	10	DIN 128
8	500 541 00	3	3	M 10x30	DIN 912-8.8
9	400 174 01	1	1		
10	400 040 00	1	1		
11	500 028 00	6	6	8	DIN 128
12	500 267 00	6	6	M 8x16	DIN 933-8.8
13	—	—	—		
14	030 322 00	1	1		
15	030 297 00	5	5		
16	400 028 00	5	5	4,0x15	AF 40 150
17	006 174 01	1	1	„FG“	
18	030 294 02	1	1		
19	030 302 01	1	1		
20	—	—	—		
21	500 353 00	2	2	6x28	DIN 1481
22	500 344 00	2	2	3,5x28	DIN 1481
23	400 150 00	1	1		
24	400 092 00	2	2		
25	500 176 00	1	1	19	DIN 433-St
26	500 200 00	1	1	18x 1,2	DIN 471
27	030 320 00	1	1		
28	004 502 01	1	1		
29	500 028 00	2	2	8	DIN 128
30	500 516 00	2	2	M 8x 16	DIN 912-8.8
31	500 229 00	1	1	M 8	DIN 934-8
32	500 271 00	1	1	BM 8x25	DIN 561-8.8 Zg
33	003 326 02	1	1	„FG“	
34	031 563 00	1	1		
35	500 027 00	6	6	6	DIN 128

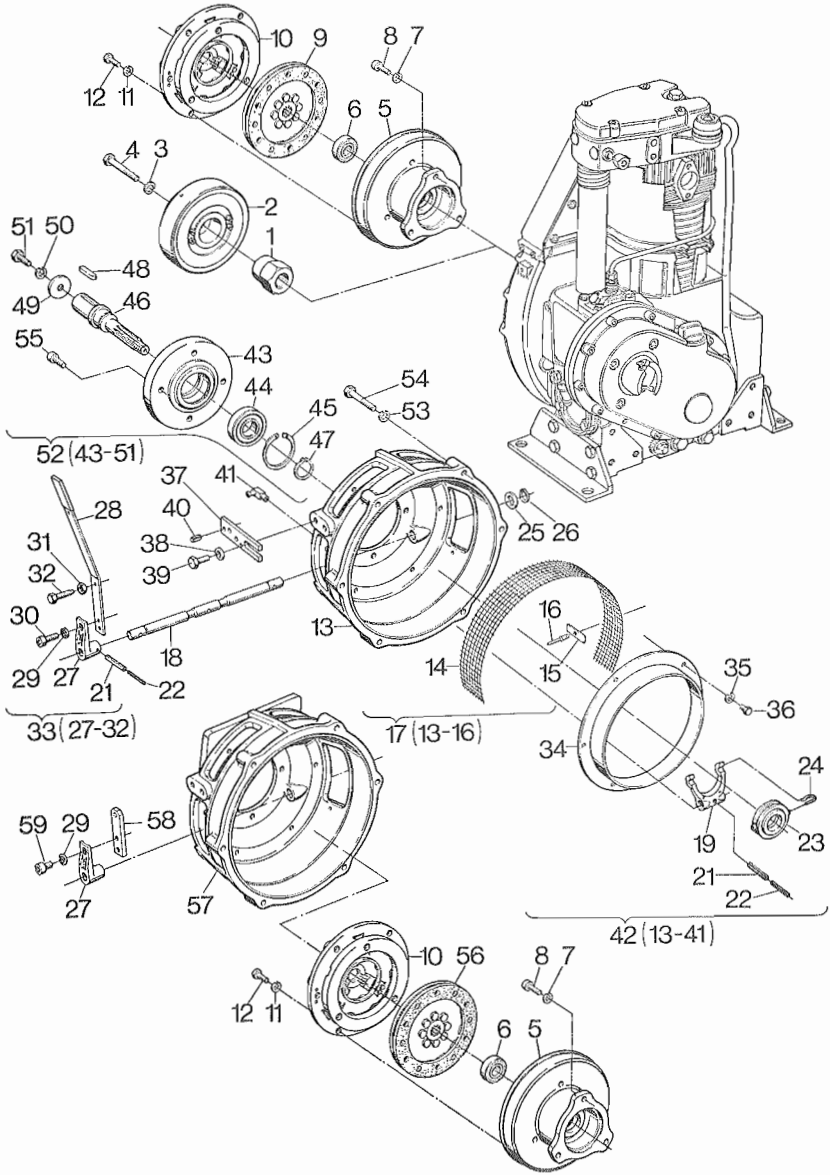

Fig. No.	Bestell-Nr. Ordering No. No. référence No. de pedido	Stück Quantity Quantités Cantidades		Hinweise Hints Indications Indicaciones	
		E 88	E 89		
36	500 253 00	6	6	M 6x8	DIN 933-8.8
37	032 621 00	1	1		
38	501 459 00	2	2	B 10,5	DIN 125-St A3C
39	500 292 00	2	2	M 10x25	DIN 933-8.8
40	500 593 00	2	2	6x16	DIN 1481
41	500 079 00	2	2	CM 8x1	DIN 71412
42	003 324 01	1	1	„FG“	
43	030 317 01	1	1		
44	500 150 00	1	1	6307 2 RS	DIN 625
45	400 276 00	1	1	JV 80x2,5	
46	030 313 03	1	1		
47	500 211 00	1	1	35x1,5	DIN 471
48	500 120 00	1	1	A 10x8x50	DIN 6885
49	033 213 00	1	1	11x45x5	
50	500 029 00	1	1	10	DIN 128
51	500 293 00	1	1	M 10x30	DIN 933-8.8
52	003 325 01	6	6		
53	500 029 00	6	6	10	DIN 128
54	500 301 00	6	6	M 10x65	DIN 931-8.8 A3C
55	500 538 00	4	4	M 10x25	DIN 912-8.8
56	400 704 01	1	1	SAE 7/8 - 10 C	
57	033 464 00	1	1	„FG“	
58	033 469 00	1	1		
59	500 514 00	2	2	M 8x12	DIN 912-8.8

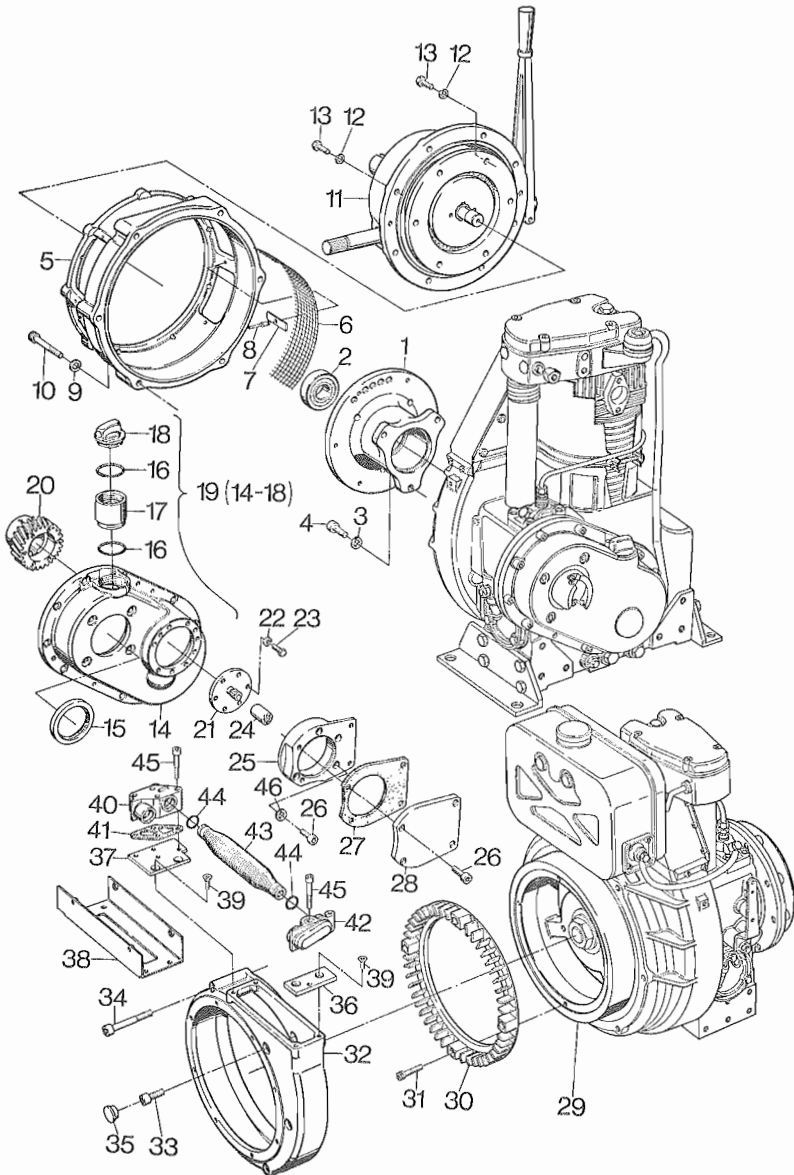

Fig. No.	Bestell-Nr. Ordering No. No. référence No. de pedido	Stück Quantity Quantités Cantidades		Hinweise Hints Indications Indicaciones
		E 88	E 89	
1	034 727 01	1	1	„FG“
2	501 142 00	1	1	„FG“ 6305 2 RS DIN 625
3	500 029 00	3	3	„FG“ 10 DIN 128
4	500 541 00	3	3	„FG“ M 10x30 DIN 912-8.8
5	034 724 00	1	1	„FG“
6	035 067 00	2	2	„FG“
7	030 297 00	6	6	„FG“
8	400 028 00	6	6	„FG“ 4,0 x 15
9	500 029 00	6	6	„FG“ 10 DIN 128
10	500 555 00	6	6	„FG“ M 10x70 DIN 912-8.8
11	400 862 00	1	1	„FG“
12	500 028 00	14	14	„FG“ 8 DIN 128
13	500 270 00	14	14	„FG“ M 8x25 DIN 933-8.8
14	—	—	—	
15	500 456 00	1	1	70x85x8 BB
16	400 236 00	2	2	
17	036 566 00	1	1	
18	031 689 01	1	1	
19	003 360 01	1	1	
20	030 395 01	1	1	
21	030 340 00	1	1	
22	500 027 00	6	6	6 DIN 128
23	500 257 00	6	6	M 6x16 DIN 933-8.8
24	400 165 00	1	1	
25	030 401 01	1	1	
26	500 521 00	8	8	M 8x25 DIN 912-8.8
27	031 611 00	1	1	
28	031 083 00	1	1	
29	035 306 00	1	1	„FG“
30	035 305 00	1	1	„FG“
31	500 523 00	4	4	„FG“ M 8x35 DIN 912-8.8
32	035 298 00	1	1	„FG“
33	500 541 00	3	3	„FG“ M 10x30 DIN 912-8.8
34	500 556 00	3	3	„FG“ M 10x80 DIN 912-8.8
35	400 333 00	3	3	„FG“
36	035 304 00	1	1	„FG“

**A 17**

Kupplung dauerausrückbar, Ölkühler  
Clutch perm. disconn., oil cooler  
Embrayage debr. continu., radiateur huile  
Embrague permanente, radiador de aceite

Tafel Nr.  
Tabl. No.

21

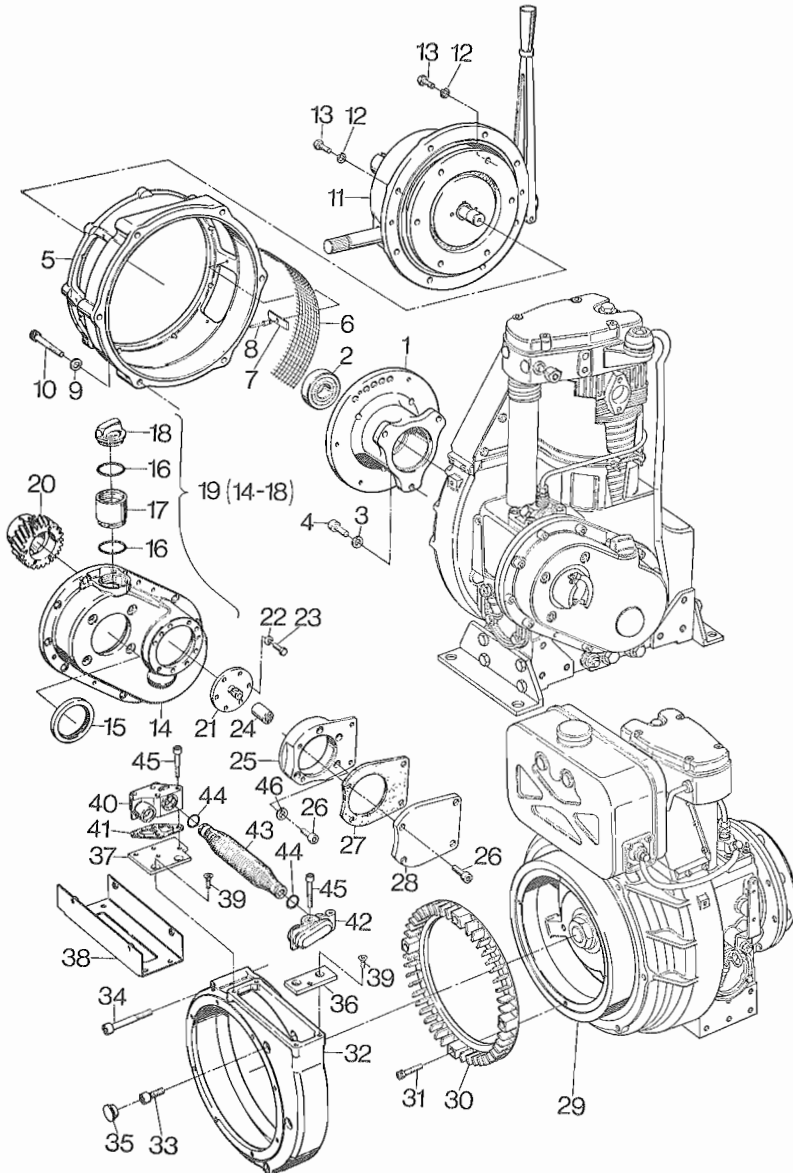



Fig. No.	Bestell-Nr. Ordering No. No. référence No. de pedido	Stück Quantity Quantités Cantidades		Hinweise Hints Indications Indicaciones
		E 88	E 89	
		37	035 296 00	
38	007 629 00	1	1	„FG“
39	501 124 00	4	4	„FG“ M 8x20 DIN 7991-8.8
40	033 530 00	1	1	„FG“
41	033 531 00	1	1	„FG“
42	033 430 02	1	1	„FG“
43	033 532 00	2	2	„FG“
44	400 798 00	4	4	„FG“ 20,3x2,4
45	500 527 00	5	5	„FG“ M 8x50 DIN 912-8.8
46	501 629 00	4	4	A 8x14            DIN 7603-Cu

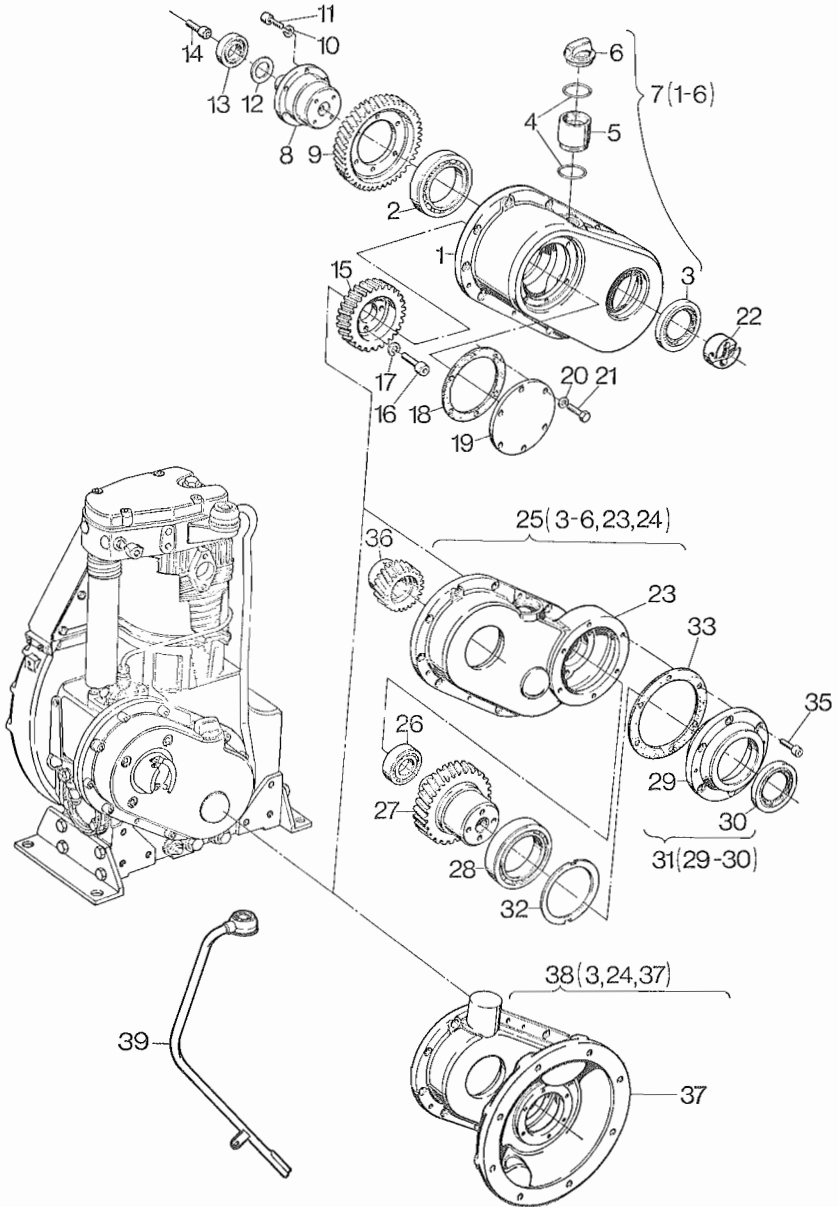

Fig. No.	Bestell-Nr. Ordering No. No. référence No. de pedido	Stück Quantity Quantités Cantidades		Hinweise Hints Indications Indicaciones	
		E 88	E 89		
1	—	—	—		
2	500 155 00	1	1	1604	DIN 625
3	500 456 00 D1	1	1		
4	400 236 00 D1	2	2		
5	036 566 00	1	1		
6	031 689 01	1	1		
7	003 296 00	1	1		
8	030 253 00	1	1		
9	030 280 01	1	1	1 : 3	
10	500 028 00	6	6	8	DIN 128
11	500 519 00	6	6	M 8 x 20	DIN 912-8.8
12	035 312 00	1	1	0,20 mm	
12	033 334 00	1	1	0,40 mm	
12	033 335 00	1	1	0,60 mm	
12	033 336 00	1	1	0,80 mm	
12	033 337 00	1	1	1,00 mm	
13	500 142 00	1	1	6206	DIN 625
14	500 562 00	1	1	M 12 x 25	DIN 6912-8.8
15	030 279 01	1	1	1 : 3	
16	500 541 00	4	4	M 10 x 30	DIN 912-8.8
17	500 029 00	4	4	10	DIN 128
18	031 265 00	1	1		
19	031 264 00	1	1		
20	500 009 00 D5	6	6	A 8 x 11,5	DIN 7603-Cu
21	500 267 00	6	6	M 8 x 16	DIN 933-8.8
22	032 222 00	1	1		
23	—	—	—		
24	—	—	—		
25	003 357 00	1	1		
26	500 470 00	1	1	NJ 207	DIN 5412
27	030 396 01	1	1	1 : 1,45	
28	500 155 00	1	1	16014	DIN 625
29	—	—	—		
30	400 347 00	1	1	70 x 85 x 8/9	
31	003 358 00	1	1		
32	033 267 00	1...2	1...2		

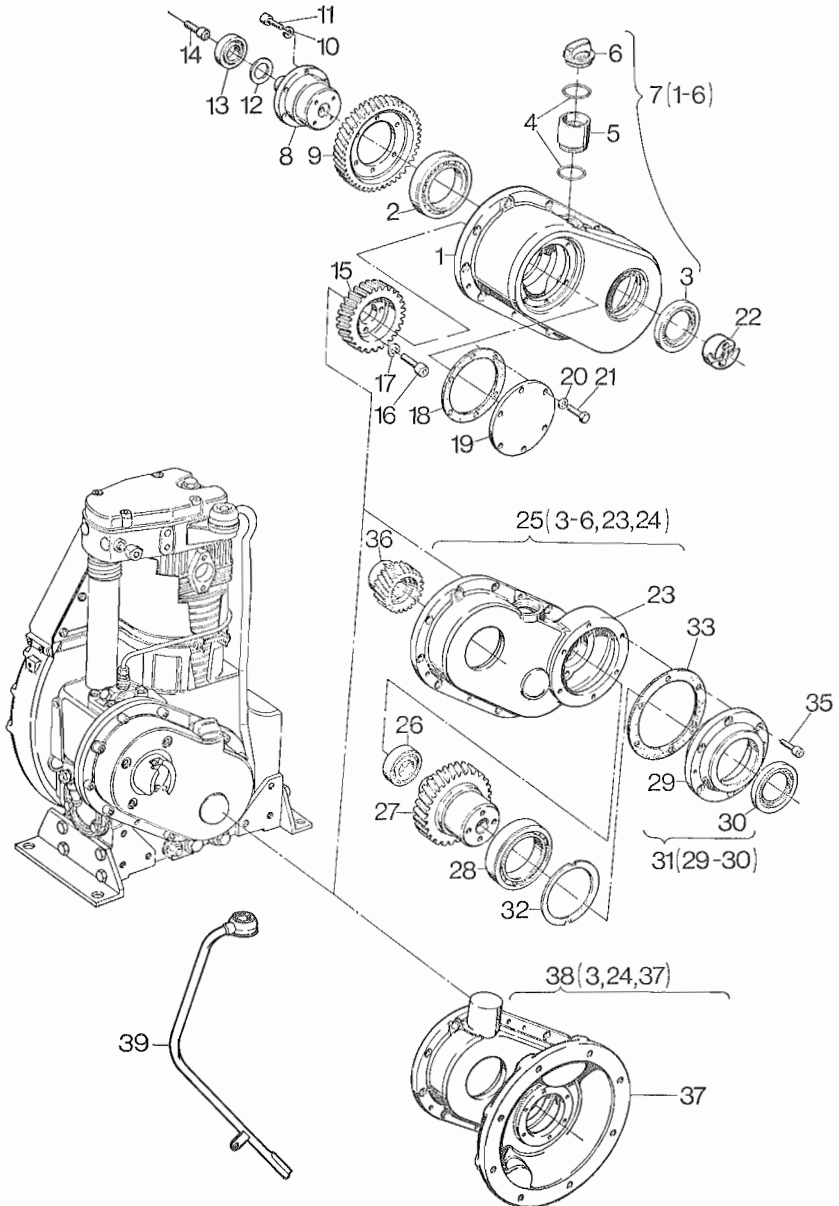

Fig. No.	Bestell-Nr. Ordering No. No. référence No. de pedido	Stück Quantity Quantites Cantidades		Hinweise Hints Indications Indicaciones	
		E 88	E 89		
33	031 607 00	1	1		
34	---	---	---		
35	500 519 00	6	6	M 8 x 20	DIN 912-8.8
36	030 397 01	1	1		
37	---	---	---		
38	008 122 00	1	1		
39	010 714 00	1	1		

### **Anhang für nicht abgebildete Zusatzausrüstung**

Weitere Zusatzausrüstungen können aus Platzgründen in der Ersatzteilliste nicht mehr detailliert dargestellt werden. Für die Bestellung von Teilen aus nicht abgebildeten Zusatzausrüstungen verwenden Sie bitte nachfolgende Übersicht. Anhand der Skizze ist die gesuchte Zusatzausrüstung auffindbar, die für den jeweiligen Motortyp zugehörige Ident-Nr. der Ausrüstung ist aus der Tabelle ersichtlich. Ihre zuständige HATZ-Vertretung kann Ihnen anhand dieser Ident-Nr. das gewünschte Ersatzteil heraussuchen.

### **Annex for additional equipment which is not illustrated**

Due to lack of space we cannot list further additional equipment in our parts list. For parts ordering not illustrated, please use the below listed survey. With the aid of sketches you can find the required additional equipment. The ident-number belonging to the corresponding engine type can be taken from the table. Your HATZ agent is in a position to select for you the required spare part as soon as you have selected the correct ident-number.

### **Annexe concernant les accessoires complémentaires non-illustrés**

Un certain nombre d'accessoires complémentaires n'ont pu, par suite d'un manque de place, être représentés d'une manière détaillée dans la liste de pièces détachées. Pour la commande de ces accessoires, qui ne sont pas illustrés, veuillez utiliser l'aperçu ci-après. A l'aide des croquis, il est possible de trouver l'accessoire souhaité, le No. ident. correspondant pour chaque type de moteur figure dans le tableau. Grâce à ce No. ident. votre représentant HATZ pourra vous trouver la pièce souhaitée.

### **En relación a equipos adicionales no ilustrados.**

Debido a razones de espacio no es posible ilustrar otros equipos adicionales en la lista de piezas. Para pedidos de equipos adicionales no ilustrados favor usen la siguiente orientación. A base de las ilustraciones es posible encontrar el equipo adicional buscado. el número ident para el tipo de motor para el cual se necesita el equipo se puede obtener de la tabla.

El representante HATZ para su area puede entonces a base del número ident encontrar las piezas deseadas.

Zusatzausrüstungen Equipements Accessoires complémentaires Equipos	Code	Ident.-Nr.	E 88	E 89	Hinweise Hints Indications Indicaciones
---	------	------------	------	------	--

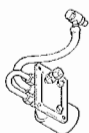

A 07.20	006 653 01	X	X
---------	------------	---	---



A 07.40	010 088 00	X	X
---------	------------	---	---



A 07.60	005 479 01	X	X
---------	------------	---	---



A 10.70	008 865 00	X	X
---------	------------	---	---



A 11.10	010 040 00	X	X
---------	------------	---	---

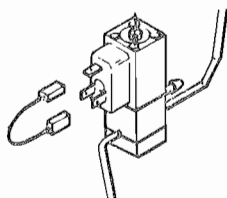

A 11.10	010 876 00	X	X	12 V
---------	------------	---	---	------

Zusatzrüstungen Equipements Accessoires complémentaires Equipos	Code	Ident.-Nr.	E 88	E 89	Hinweise Hints Indications Indicaciones
--	------	------------	------	------	--

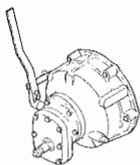

A 20.11	008 874 00	X	X	i = 1.8
---------	------------	---	---	---------



**Serien-Nr.-Änderungen**  
**Serial-code modification list**  
**Modification des Nos de serien**  
**Modificación de los Nos de serie**

**E 88**

Bildtafel	Pos. Nr.	Bestell-Nr.	Stück	Bildtafel	Pos. Nr.	Bestell-Nr.	Stück	IMT NO.
Table	Fig. No.	Ordering No.	Qty.	Table	Fig. No.	Ordering No.	Qty.	
Planche	Fig. No.	No. référence	Qté.	Planche	Fig. No.	No. référence	Qté.	
Tabla	Fig. No.	No. de pedido	Cant.	Tabla	Fig. No.	No. de pedido	Cant.	
								84.422
02	46	031 501 00	1	03	46	033 272 00	1	
02	47	500 009 00	1	03	47	500 624 00	1	
02	48	500 333 00	1	03	48	500 623 00	1	
13	06	400 204 00	1	12	1	010 785 00	1	—
13	07	400 404 00	1	12	2	400 367 00	1	—
13	11	032 300 00	1	12	11	011 587 00	1	—

**Serien-Nr.-Änderungen**  
**Serial-code modification list**  
**Modification des Nos de serien**  
**Modificación de los Nos de serie**

**E 89**

Bildtafel	Pos. No.	Bestell-Nr.	Stück	Bildtafel	Pos. No.	Bestell-Nr.	Stück	IMT NO.
Table	Fig. No.	Ordering No.	Qty.	Table	Fig. No.	Ordering No.	Qty.	
Planche	Fig. No.	No. référence	Qté.	Planche	Fig. No.	No. référence	Qté.	
Tabla	Fig. No.	No. de pedido	Cant.	Tabla	Fig. No.	No. de pedido	Cant.	
E 89.13				E 89.14				81.345
07	40	500 063 00	1	08	17	036 623 00	1	
				08	15	500 158 00	1	
				08	18	036 737 00	1	
				08	19	008 055 00	1	
				08	20	036 740 00	1	
				08	22	036 642 00	1	
				08	21	501 578 00	1	
				08	7	500 157 00	1	
								84.422
02	46	031 501 00	1	03	46	033 272 00	1	
02	47	500 009 00	1	03	47	500 624 00	1	
02	48	500 333 00	1	03	48	500 623 00	1	
13	06	400 204 00	1	12	1	010 785 00	1	—
13	07	400 404 00	1	12	2	400 367 00	1	—
13	11	032 300 00	1	12	11	011 587 00	1	—