

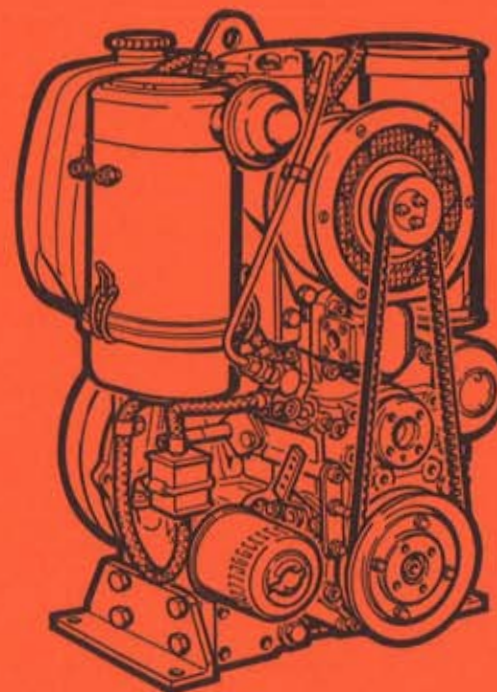

MOTORENFABRIK HATZ GMBH & CO KG · D-8399 RUHSTORF a. d. ROTT
TEL. (08531) 3021 · TELEX 57260

Ersatzteil-Liste
Spare parts list
Liste des pièces de rechange
Lista de recambios



E 950

WICHTIG – Bitte Daten eintragen
IMPORTANT – Compléter les données

IMPORTANT – Please enter data
IMPORTANTE – Favor completar datos

1.

Bitte hier **Type**, **Motornummer** und **Drehzahl** (siehe Motor-Typenschild) eintragen.

Enter here **type engine no.** and **rpm.** (see engine type-plate).

Indiquer ici le **type**, **N° de moteur** et **régime** (voir plaque signalétique).

Insertar aquí **tipo- N° motor** y **r.p.m.** (vea placa del motor).

MOTORENFABRIK HATZ ^{GMBH} KG ¹ CO			
D-8399 RUHSTORF/ROTT			
TYP	KENNZ.		
MOTOR/FABRIK NO.		ABE/AUSEF.	
MIN ⁻¹	NH	PV	CM ³
HATZ			
DIESEL			
MADE IN GERMANY (FED. REP.)			

1

Ersatzteilliste Nr.

Spare parts list no.

Liste des pièces de rechange no.

Lista de recambios no.

E 950.18

2

3.

Bitte tragen Sie hier die **Anschrift** Ihrer nächsten HATZ-Service-stelle ein.

Insert here **address** of your next HATZ Service station.

Indiquer ici l'**adresse** de votre stationservice HATZ la plus proche.

Insertar aquí **dirección** de servicio HATZ más cercano.

HATZ-Service

3

MOTORENFABRIK HATZ
GmbH & Co. KG
D - 8399 RUHSTORF a. d. ROTT
Federal Republic of Germany
☎ (085 31) 30 21 — Telex 5 7260

1

Angaben bei Ersatzteilbestellungen:

Zur richtigen und schnellen Belieferung mit Ersatzteilen sind folgende Angaben erforderlich:

1. **Type, Motornummer und Drehzahl** des Motors, für den das Ersatzteil benötigt wird: siehe Angaben auf Seite 1, Feld 1.
2. **Nummer der Ersatzteilliste**, aus der die Bestellnummer herausgelesen wurde: siehe Seite 1.
3. **Stückzahl und Bestell-Nr.** des gewünschten Ersatzteils.
4. Gewünschte **Versandart**, z. B. Post, Luftfracht, Express.
5. Genaue **Versandadresse**, wenn erforderlich mit Post- u. Bahnstation.

Bestellbeispiel:

Für Motortype: E 950 - 152 e
Motornummer: 441887011231
min⁻¹: 2700/190

aus Ersatzteilliste E 950.18
folgende Teile:

Stück	Bestell-Nr.
2	006 338 00
6	031 684 00

per Postexpress an

Die Ersatzteilbestellung richten Sie bitte an:

— die nächste HATZ-Servicestelle, Anschrift siehe Seite 1, Feld 3 oder separates Servicestellenverzeichnis

— oder an die

Motorenfabrik Hatz GmbH & Co. KG
D-8399 Ruhstorf a. d. Rott
Federal Republic of Germany
☎ (085 31) 30 21 — Telex 57260

Particulars for spare parts orders:

The following information is needed to ensure correct and prompt supply of spare parts:

1. **Engine type, engine number and r.p.m.** of the engine for which you need the spare part.
See particulars on page 1, field 1.
2. **Number of spare parts list** from which you took the ordering no., see page 1.
3. **Quantity and ordering no.** of requested spare part.
4. Requested **mode of dispatch**, e. g. surface / airmail, airfreight, express.
5. Exact **shipping address**, if necessary indicate local post office and/or railway station.

Example for your order:

For engine type: E 950 - 152 e
Engine number: 441887011231
R. p. m.: 2700/190

Spare parts list no. E 950.18

The following parts:

Qty.	ordering-no:
2	006 338 00
6	031 684 00

to be mailed, express, to

Please address your spare parts order to:

— your nearest Hatz service station, address see page 1, field 3 or separate Hatz-service-List

— or to

Motorenfabrik Hatz GmbH & Co. KG
D-8399 Ruhstorf a. d. Rott
Federal Republic of Germany
☎ (085 31) 30 21 — Telex 57260

Données à indiquer lors de vos commandes de pièces détachées:

Pour nous permettre de livrer vos pièces rapidement et correctement, nous avons besoin des données suivantes:

1. **Type, No. et régime du moteur** pour lequel vous avez besoin de pièces: voir données page 1, carré 1.
2. **No. de la liste de pièces de rechange** dans laquelle figure le No. de commande: voir page 1.
3. **Quantité et No. de commande** de la pièce souhaitée.
4. **Mode d'expédition** souhaitée: par ex. par poste, fret aérien, exprès.
5. **Adresse exacte de destination** et, lorsque ceci est nécessaire, le nom de la poste et de la gare, ou aéroport.

Exemple:

Pour type de moteur: E 950 - 152 e
No. moteur: 441887011231
Régime: 2700/190

Liste de pièces de rechange: E 950.18
Les pièces suivantes:

Qté.	No. commande
2	006 338 00
6	031 684 00

par poste exprès à

Les commandes de pièces détachées sont à adresser à:

— votre station-service HATZ la plus proche, voir adresse page 1, carré 3 ou liste de service séparée.

— ou

Motorenfabrik Hatz GmbH & Co. KG
D-8399 Ruhstorf a. d. Rott
République Fédérale d'Allemagne
☎ (0 85 31) 30 21 — Telex 5 7260

Datos para pedidos de recambios:

Para recibir sus recambios en forma rápida y correcta necesitamos las siguientes informaciones:

1. **Tipo, número del motor y revoluciones:**
ver detalles en página 1, posición 1.
2. **Número de la lista de recambios** de la cual se ha obtenido el número de pedido: ver página 1.
3. **Cantidad y número de pedido** del recambio deseado.
4. **Tipo de despacho deseado:** por ej. correo, fiete aereo, expreso etc.
5. **Dirección exacta**, si necesario indicar la oficina de correo, la estación ferrocarril o aeropuerto.

Ejemplo de pedido:

Para motor tipo: E 950 - 152 e
Número de motor: 441887011231
R. P. M.: 2700/190

De la lista de recambios: E 950.18
Sigüientes recambios:

Cantidad	Número de pedido
2	006 338 00
6	031 684 00

Por correo expreso a

El pedido de recambios favor dirigirlo a:

— Al servicio HATZ más cercano, dirección verla en página 1, position 3 o en el índice separado de direcciones de servicio.

— Alternativa a:

Motorenfabrik Hatz GmbH & Co. KG
D-8399 Ruhstorf a. d. Rott
República Federal de Alemania
☎ (0 85 31) 30 21 — Telex 5 7260

Inhaltsverzeichnis:		Index:	
M ...	Grundmotor	Basic engine	
00, 34	Ersatzteilsätze, Zubehör	Spare parts kits, accessories	01
01	Kurbelgehäuse	Crankcase	02
01, 10	Kurbelgehäuse, Ölpumpe	Crankcase, oil pump	03
02, 03	Kurbelwelle, Lagerflansch	Crankshaft, bearing flange	04
04, 11	Nockenwelle, Steuerdeckel	Camshaft, timing cover	05
05, 06	Kolben, Pleuel, Zylinder	Piston, conrod, cylinder	06
07	Zylinderkopf	Cylinder head	07
13	Gebälse, Luftführung	Blower, air ducting	08
14, 17	Einspritzausrüstung, Schwungrad, Startfüllung	Injection equipment, flywheel, extra fuel device	09
32	Drehzahlverstellung	Speed control	10
A ...	Zusatzausrüstungen	Equipments	
01	Kraftstoffbehälter, Filter, Leitungen	Fuel tank, filter, pipes	11
02-04	Luftfilter, Auspuff, Andrehkurbel	Air filter, exhaust silencer, starting handle	12
05	Starter, Generator, Armaturen	Starter, alternator, el. equipment	13
10	Kühlgebläseüberwachung	Air blower control	14
10	Kraftstoffabsperrventil	Shut-off valve	15
16	Wellenstummel, Elast. Kupplung	Stubshaft, flexible coupling	16
			Seite/Page
	Weitere Zusatzausrüstungen	Further additional equipment	52
	Änderungsübersicht	Modification table	56

Sommaire:

Indice:

M...	Moteur de base	Motor de base	
00, 34	Jeux de pièces de rechange, accessoires	Juegos de piezas de recambios, accesorios	01
01	Carter moteur	Caja cigueñal	02
01, 10	Carter moteur, Pompe a huile	Caja cigueñal, Bomba de aceite,	03
02, 03	Vilebrequin, palier	Cigueñal, brida de cojinete	04
04, 11	Arbre à cames, couvercle distribut.	Arbol de levas, tapa de mando	05
05, 06	Piston, bielle, cylindre	Embolo, biela, cilindro	06
07	Culasse	Culata	07
13	Soufflerie, carter ventilation	Ventilador, conducción de aire	08
14, 17	Equipment d'injection, volant, surcharge	Equipo de inyección, volante, sobre alément - arranque	09
32	Reglage régime, bride moteur	Ajuste de revoluciones	10

A...	Accessoires	Equipos	
01	Reservoir à carburant, filtre, conduites	Deposito combustible, filtro, tuberia	11
02-04	Filtre à air, silencieux, manivelle	Filtro de aire, silenciador, manivela	12
05	Demarreur, alternateur, équipement électrique	Arrancador, alternador, equipo eléctrico	13
10	Surveill. ventilat.	Disp. desconectador	14
10	Soupape d'arrêt	Válvula cierre	15
16	Bout d'arbre, accouplement elastic	Eje, acoplamiento elast.	16

Page/Página No.

Autres accessoires complémentaires	Otros equipos adicionales	52
Aperçu de modification	Tabla de modificaciones	56

M 00

Ersatzteilsätze
Spare parts kits
Jeux de pièces de rechange
Juegos de piezas de recambios

M 34

Zubehör
Accessories
Accessoires
Accessorios

Tafel Nr.
Tabl. No.
01

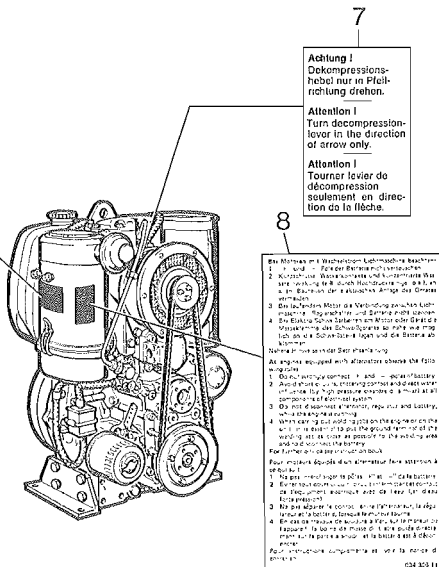
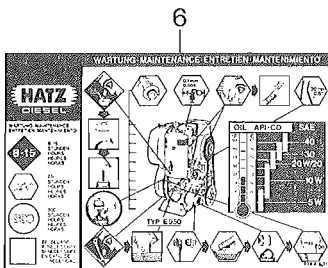
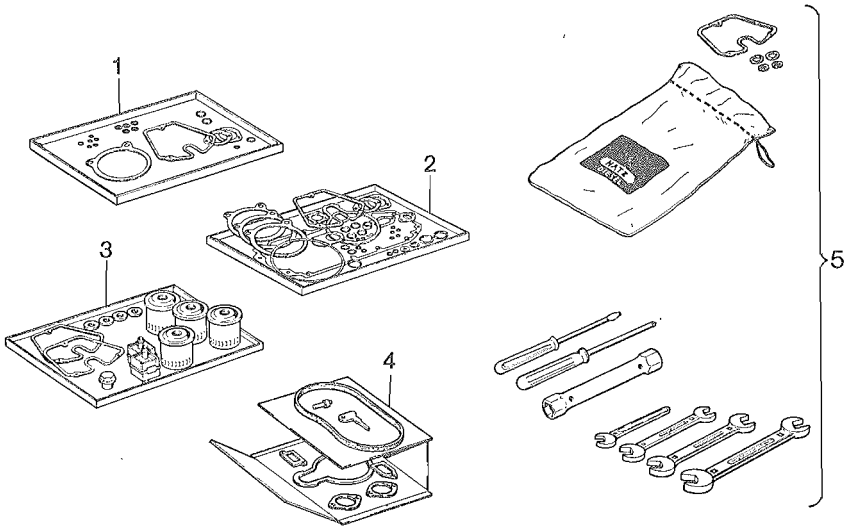

Fig. No.	Bestell-Nr. Ordering No. No. référence No. de pedido	Stück Quantity Quantités Cantidades	Hinweise Hints Indications Indicaciones
			<p>P: Im Pannensatz enthalten. -- Incl. in emergency kit. -- Contenu dans le jeu secur. -- Contenido en el juego para averjas.</p> <p>W: Im Wartungssatz enthalten. -- Incl. in maintenance kit. -- Contenu dans le jeu d'entretien. -- Contenido en el juego de mantenimiento.</p> <p>1: Anzahl pro Satz. -- Qty. per kit. -- Quantjite par jeu. -- Cantidad por juego.</p>
1	007 037 10 P1	1	Dichtungssatz f. 1 Zylinderkopf Gasket set for 1 cyl. head Jeu de joint p. 1 culasse Juego de juntas para 1 culata
2	012 301 00	1	Dichtungssatz Kurbelgehäuse Gasket set crankcase Jeu de joints carter moteur Juego de juntas caja cigueñal
3	009 617 01	1	Wartungssatz für 1000 h 1000 hours maintenance kit Kit d'entretien 1000 heures Juego de piezas para mantenimiento 1000 horas.
4	009 664 03	1	Pannensatz Emergency kit Kit de secours Juego para averias
5	007 368 00	1	Zubehörsatz Accessories kit Sort. accessoires Juego de accesorios
6	036 316 01	1	
7	033 963 01	1	
8	034 306 11	1	

M 01

Kurbelgehäuse
Crankcase
Carter moteur
Caja cigueñal

Tafel Nr.
Tabl. No.

02

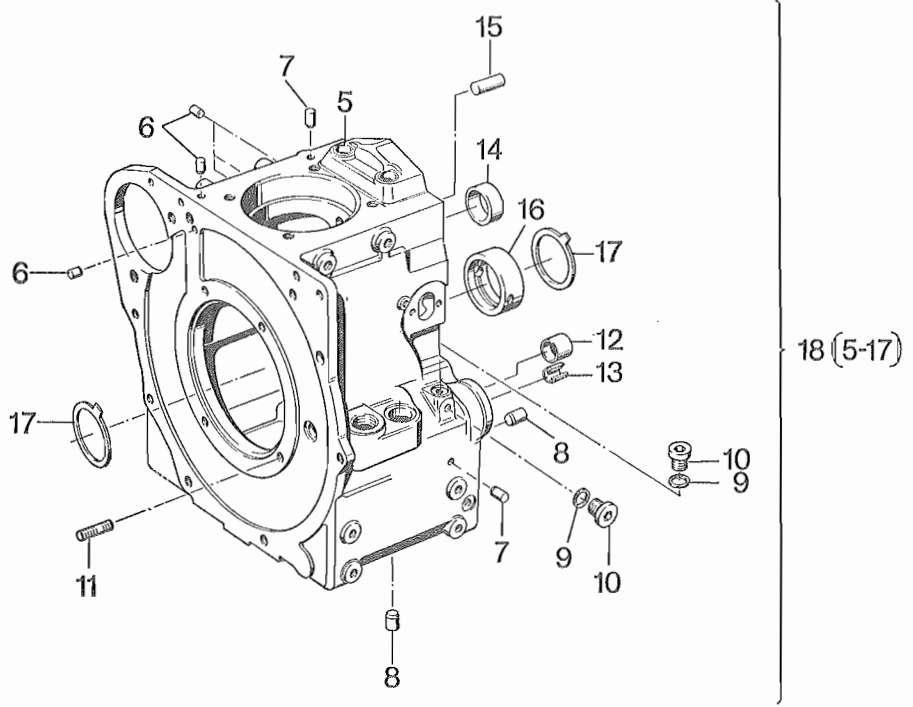

Fig. No.	Bestell-Nr. Ordering No. No. référence No. de pedido	Stück Quantity Quantités Cantidades	Hinweise Hints Indications Indicaciones	
1	—	—		
2	—	—		
3	—	—		
4	—	—		
5	—	—		
6	—	—		
7	032 123 00	2		
8	—	—		
9	500 624 00	2	A 10 x 13,5	DIN 7603 - Cu
10	500 623 00	2	M 10 x 1	DIN 908-4.6A3C
11	500 401 00	4	M 10 x 20	DIN 835 - 8.8
12	033 651 00	1		
13	500 357 00	1	11 x 12	DIN 7346
14	034 345 00	1		
15	501 150 00	2	10 M 6 x 20	DIN 7-9 S 20 K
16	033 679 00	1		
16	034 567 00	1	— 0,5 mm	
17	033 680 00	2		
18	007 312 02	1		

M 01 Kurbelgehäuse
Crankcase
Carter moteur
Caja cigueñal

M 10 Ölpumpe
Oil pump
Pompe a huile
Bomba de aceite

Tafel Nr.
Tabl. No.
03

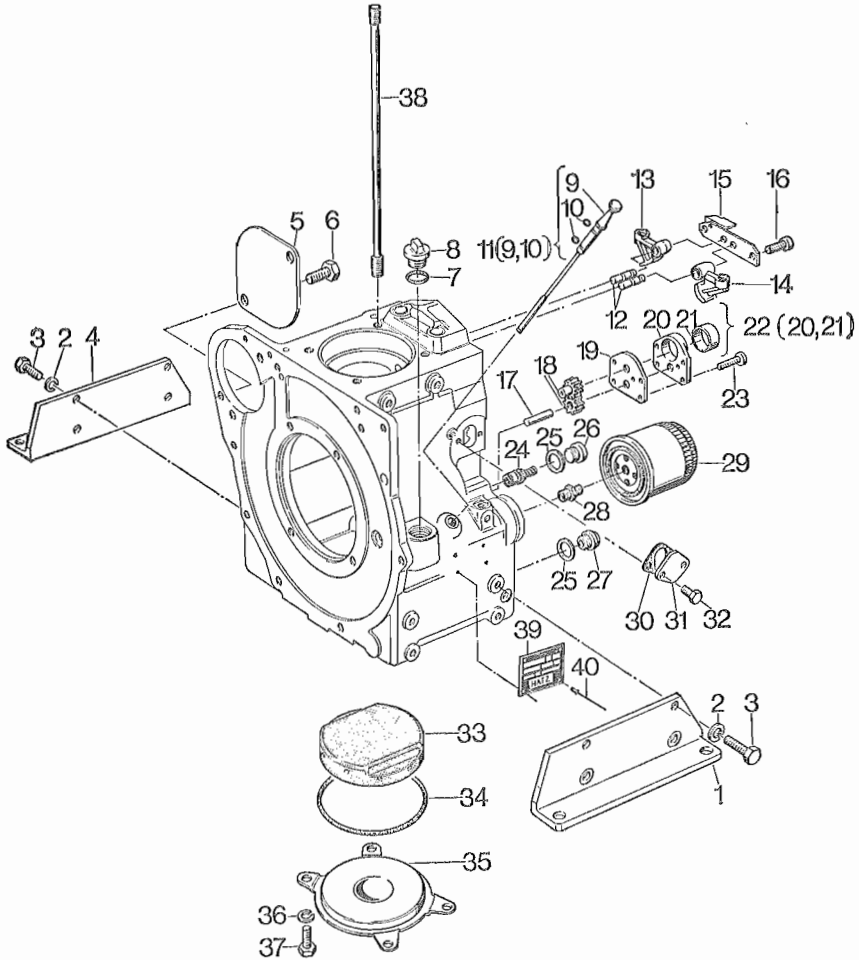

Fig. No.	Bestell-Nr. Ordering No. No. référence No. de pedido	Stück Quantity Quantités Cantidades	Hinweise Hints Indications Indicaciones
1	030 319 00	1	
2	500 029 00	8	10
3	500 293 00	8	M 10 x 30
4	030 338 00	1	
5	030 331 00	1	
6	500 308 00	2	M 12 x 16
7	501 538 00	1	23 x 3
8	030 690 04	P1 1	
9	—	—	
10	400 220 00	2	
11	006 136 00	1	
12	034 360 00	2	
13	034 361 00	1	
14	034 362 00	1	
15	007 364 00	1	
16	500 536 00	2	M 10 x 20
17	034 357 00	1	
18	007 313 02	1	
19	034 355 01	1	
20	—	—	
21	034 345 00	1	
22	007 318 01	1	
23	501 144 00	4	M 8 x 25
24	003 288 01	1	
25	500 016 00	W4 2	A 22 x 27
26	500 443 00	1	M 22 x 1,5
27	500 444 00	W1 1	CM 22 x 1,5
28	400 654 00	1	
29	400 381 00	W4 1	
30	034 387 00	1	
31	034 386 00	1	
32	500 266 00	2	M 8 x 12
33	034 468 00	1	
34	502 229 00	1	100 x 4
35	030 032 01	1	
36	500 028 00	4	8
37	500 267 00	4	M 8 x 16
38	031 483 00	4	
39	032 255 03	1	
40	400 025 00	4	

M 02
Kurbelwelle
Crankshaft
Vilebrequin
Cigüeñal

M 03
Lagerflansch
Bearing flange
Palier
Brida de cojinete

Tafel Nr.
Tabl. No.
04

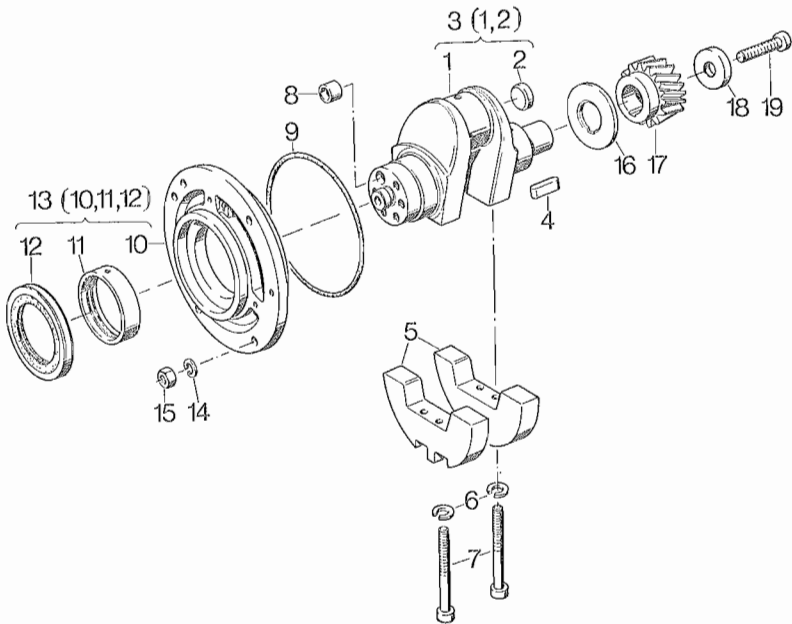

Fig. No.	Bestell-Nr. Ordering No. No. référence No. de pedido	Stück Quantity Quantités Cantidades	Hinweise Hints Indications Indicaciones
1	—	—	
2	500 432 00	1	25
3	006 468 01	1	DIN 443
4	500 113 00	1	A 8 x 7 x 22
5	033 654 00	2	
6	500 029 00	4	10
			DIN 128
7	500 550 00	4	M 10 x 50
8	031 237 00	1	
9	400 371 00	1	
10	031 218 03	1	
11	032 135 00	1	
11	032 625 00	1	—0,5 mm
12	501 147 01	1	
13	003 638 01	1	
14	500 029 00	4	10
			DIN 128
15	500 235 00	4	M 10
16	033 911 00	1	
17	033 707 00	1	
18	034 369 00	1	
19	501 153 00	1	M 12 x 1,5 x 40
			DIN 6912 - 8.8

Fig. No.	Bestell-Nr. Ordering No. No. référence No. de pedido	Stück Quantity Quantités Cantidades	Hinweise Hints Indications Indicaciones
1	033 681 02	1	
2	501 122 00	3	M 8 x 18
3	500 822 00	1	DIN 939 - 10.9
4	501 152 00	1	
5	500 016 00	1	A 22 x 27
6	500 444 00	1	CM 22 x 1,5
			DIN 7603 - Cu
			DIN 7604
7	500 821 00	1	
8	500 820 00	1	
9	400 821 00	2	
10	—	—	
11	033 914 00	1	
12	007 346 00	1	3000 min ⁻¹
13	500 113 00	1	A 8 x 7 x 22
			DIN 6885
14	400 656 00	1	
15	500 216 00	1	45 x 1,75
			DIN 471
16	033 708 00	1	
17	—	—	
18	034 471 00	1	
19	—	—	
20	—	—	
21	007 316 10	1	
22	501 129 00	1	A 6 x 4 x 36
			DIN 6885 St-60
23	033 678 10	1	
24	036 376 00	2	1500 min ⁻¹
24	036 447 00	2	1800m in ⁻¹
24	036 377 00	2	≤2300 min ⁻¹
24	036 378 00	2	>2300 min ⁻¹
25	502 200 00	16	5 x 10 x 1,0
			DIN 988 > 1800 min ⁻¹
26	502 019 00	2	
27	500 346 00	2	4 x 18
			DIN 1481
28	502 020 01	1	
29	033 929 00	1	
30	034 324 00	1	
31	400 811 00	4	6 x 22
32	031 699 01	1	
33	500 576 00	1	M 12 x 1,5 x 28
			DIN 6912 - 10.8

Fig. No.	Bestell-Nr. Ordering No. No. référence No. de pedido	Stück Quantity Quantités Cantidades	Hinweise Hints Indications Indicaciones	
34	034 032 00	2		
35	034 422 00	7		
36	400 283 00	4	M 6	SSN 440 - 8 Cu
37	502 198 00	2	5 x 10 x 0,1	DIN 988
38	502 199 00	2	5 x 10 x 0,2	DIN 988

M 05

Kolben, Pleuel
Piston, conrod
Piston, bielle
Embolo, biela

M 06

Zylinder
Cylinder
Cylindre
Cilindro

Tafel Nr.
Tabl. No.

06

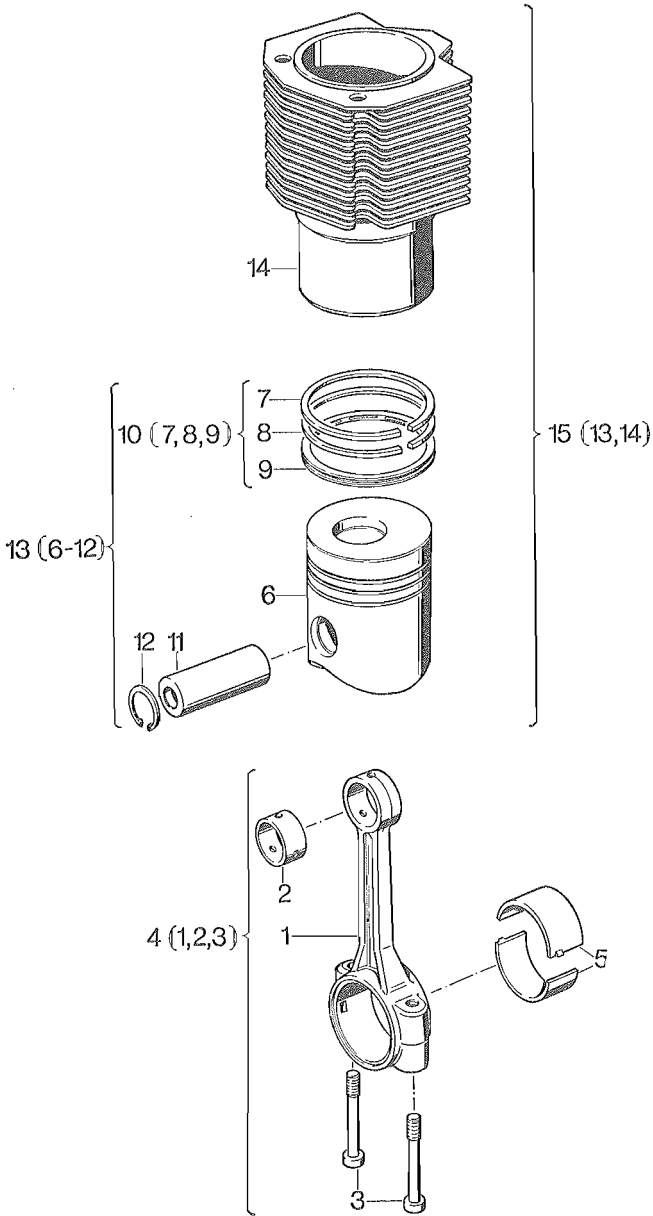

Fig. No.	Bestell-Nr. Ordering No. No. référence No. de pedido	Stück Quantity Quantités Cantidades	Hinweise Hints Indications Indicaciones
1	—	—	
2	032 020 00	1	
3	031 704 00	2	
4	005 624 00	1	
5	033 682 00	1	
5	034 568 00	1	-0,5 mm
6	—	—	
7	—	—	
8	—	—	
9	—	—	
10	006 470 00	1	
10	007 354 00	1	+1,0 mm
11	501 064 00	1	
12	500 208 00	2	30 x 1,2
13	006 469 00	1	
13	007 357 00	1	+1,0 mm
14	033 662 00	1	
15	007 317 00	1	

DIN 472

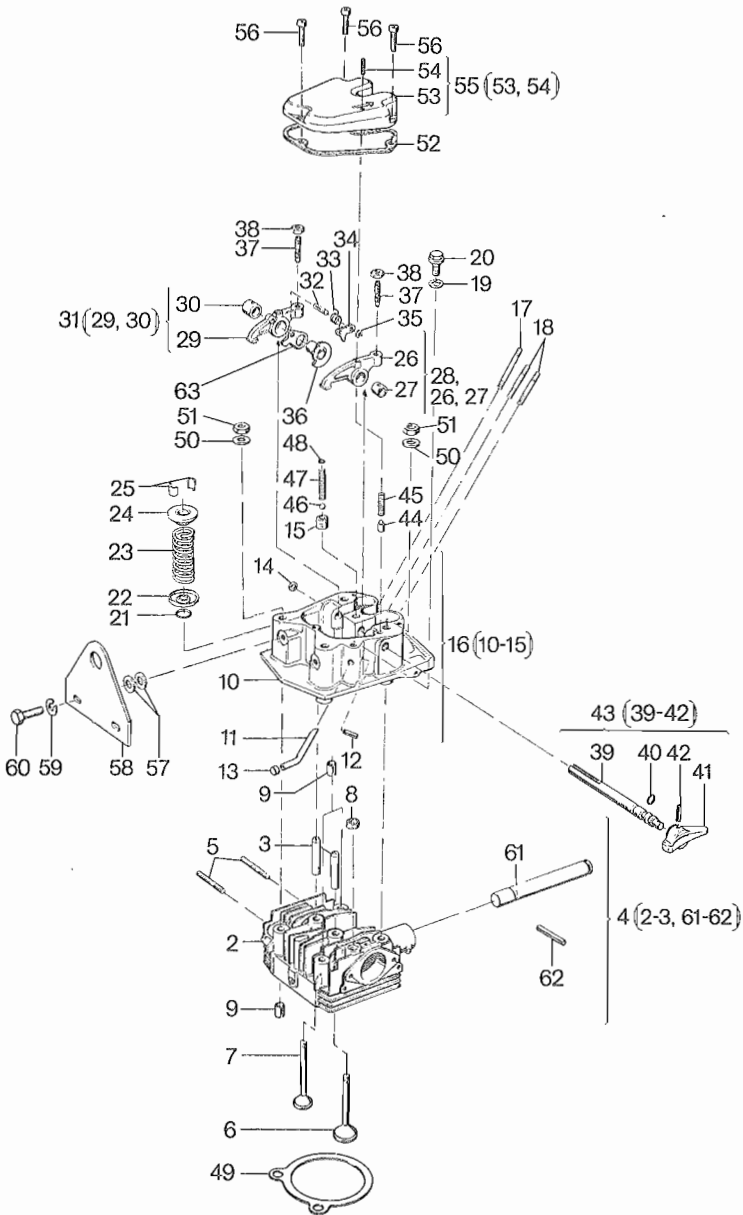

Fig. No.	Bestell-Nr. Ordering No. No. référence No. de pedido	Stück Quantity Quantités Cantidades	Hinweise Hints Indications Indicaciones
2	—	—	
3	034 487 01	2	
4	006 474 02	1	
5	500 379 00	2	M 8 x 25
6	036 145 00	1	
7	036 146 00	1	
8	400 734 00	1	
9	501 151 00	4	16 x 22
10	—	—	
11	—	—	
12	—	—	
13	—	—	
14	—	—	
15	034 589 10	1	
16	007 314 06	1	
17	501 110 00	1	M 6 x 55
18	501 111 00	2	M 6 x 35
19	032 288 00	1	
20	500 447 00	1	R 1/4"
21	400 228 00	2	
22	033 930 10	2	
23	033 256 00	2	
24	030 434 02	2	
25	036 209 00	2	
26	—	—	
27	033 652 00	1	
28	006 477 00	1	
29	—	—	
30	034 408 00	1	
31	006 478 00	1	
32	501 170 00	1	B 5 x 16
33	033 660 01	1	
34	033 657 10	1	
35	501 172 00	1	4
36	034 459 10	1	
37	030 431 00	2	

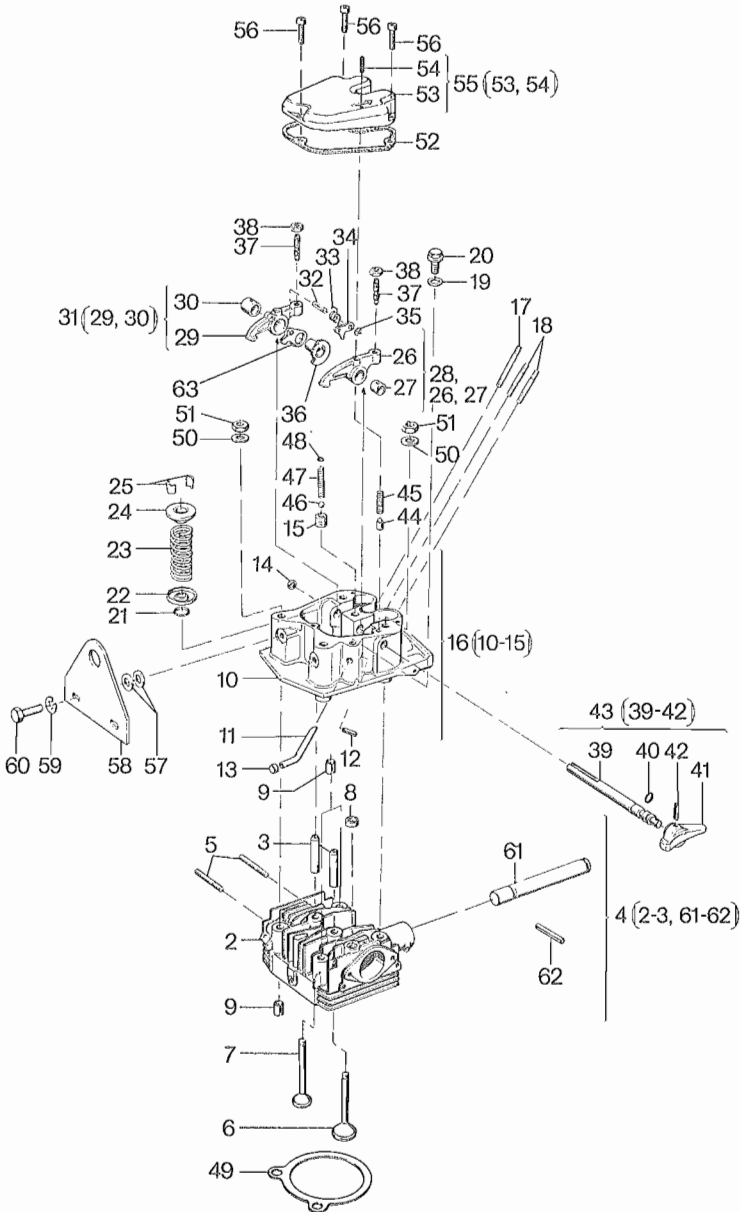

Fig. No.	Bestell-Nr. Ordering No. No. référence No. de pedido	Stück Quantity Quantités Cantidades	Hinweise Hints Indications Indicaciones	
38	031 490 00 W2	2		
39	—	—		
40	400 815 00	1		
41	036 009 00	1		
42	500 346 00	1	4 x 18	DIN 1481
43	007 315 10	1		
44	034 441 01 P1	1		
45	033 659 01 P1	1		
46	501 238 00 P1	1	7 mm III	DIN 5401
47	035 697 00 P1	1		
48	501 542 00 W1	1		
49	033 667 00	1	0,5 mm	
49	033 668 00	1	0,6 mm	
49	033 669 00	1	0,8 mm	
50	034 575 00 P4	4		
51	033 665 00 P4	4		
52	033 941 00 W2	1		
53	—	—		
54	—	—		
55	007 438 10	1		
56	500 508 00	3	M 6 x 18	DIN 912 - 8.8
57	500 169 00	4	B 10,5	DIN 125 - St
58	033 296 00	1		
59	500 029 00	2	10	DIN 128
60	500 538 00	2	M 10 x 25	DIN 912 - 8.8
61	033 943 00	1		
62	500 350 00	1	5 x 40	DIN 1481
63	037 784 00	1		

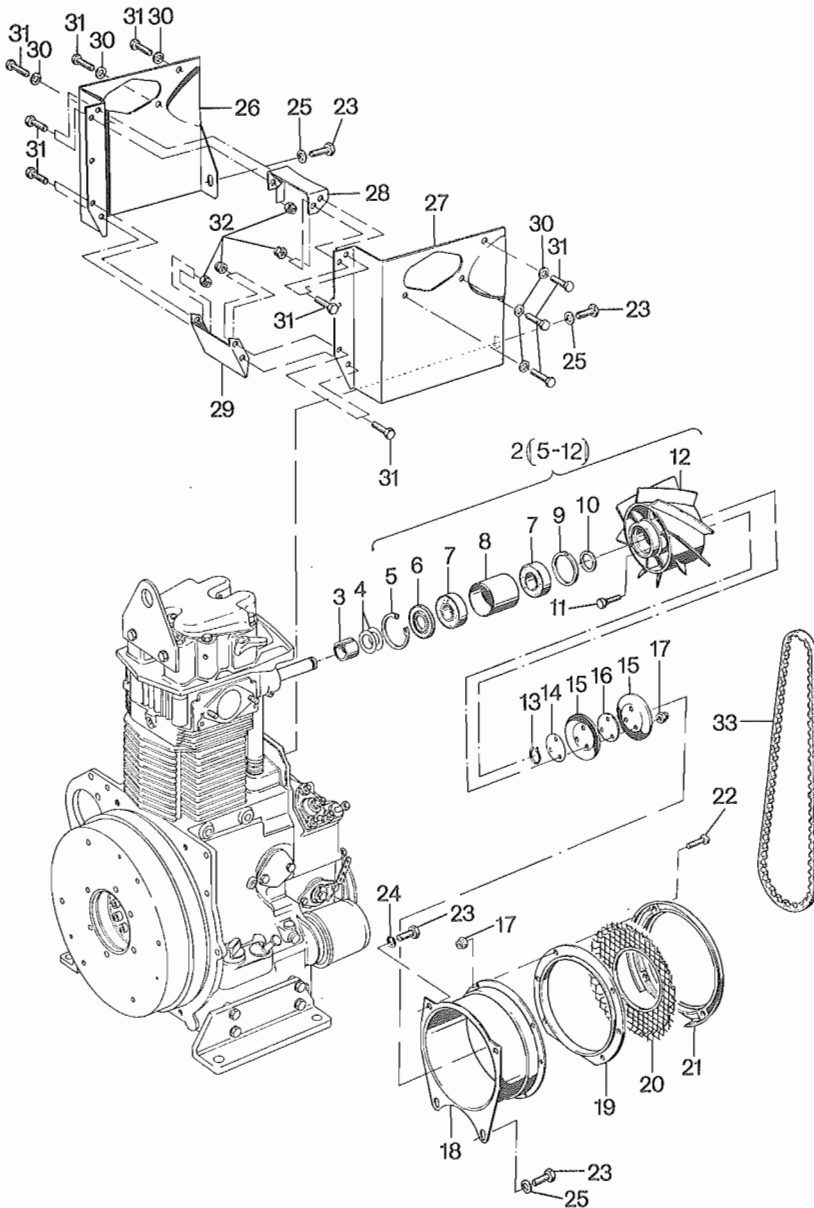

Fig. No.	Bestell-Nr. Ordering No. No. référence No. de pedido	Stück Quantity Quantités Cantidades	Hinweise Hints Indications Indicaciones
1	—	—	
2	007 325 03	1	
3	033 944 00	1	
4	400 832 00	2	
5	400 830 00	1	
6	400 831 00	1	
7	501 185 00	2	
8	033 980 01	1	
9	033 981 00	1	
10	400 736 00	1	
11	400 738 00	3	
12	006 390 02	1	
13	500 203 00	1	20 x 1,2 DIN 471
14	034 445 01	1	
15	034 030 01	2	
16	034 031 01	7	
17	400 282 00	3	M 6 SSN 440-8Cu
18	005 778 00	1	
18	039 015 00	1	f. Taf./Tabl. 13, Pos. 35-42
19	033 971 00	1	
20	006 128 00	1	
21	033 970 00	1	
22	501 109 00	6	M 5 x 16 DIN 84 - 4.8
23	500 267 00	6	M 8 x 16 DIN 933 - 8.8
24	500 028 00	2	8 DIN 128
25	500 167 00	4	8,4 DIN 125 St
26	033 915 00	1	
27	033 916 00	1	
28	034 382 00	1	
29	034 383 00	1	
30	500 166 00	6	6,4 DIN 125 - St
31	500 255 00	14	M 6 x 12 DIN 933 - 8.8
32	400 283 00	8	M 6 SSN 440-8Cu
33	400 829 00 P1	1	9,5 x 1100

M 14

Einspritzausrstung
Injection equipment
Equipement d'injection
Equipo de inyeccin

M 17

Schwungrad
Flywheel
Volant
Volante

Tafel Nr.
Tabl. No.

09

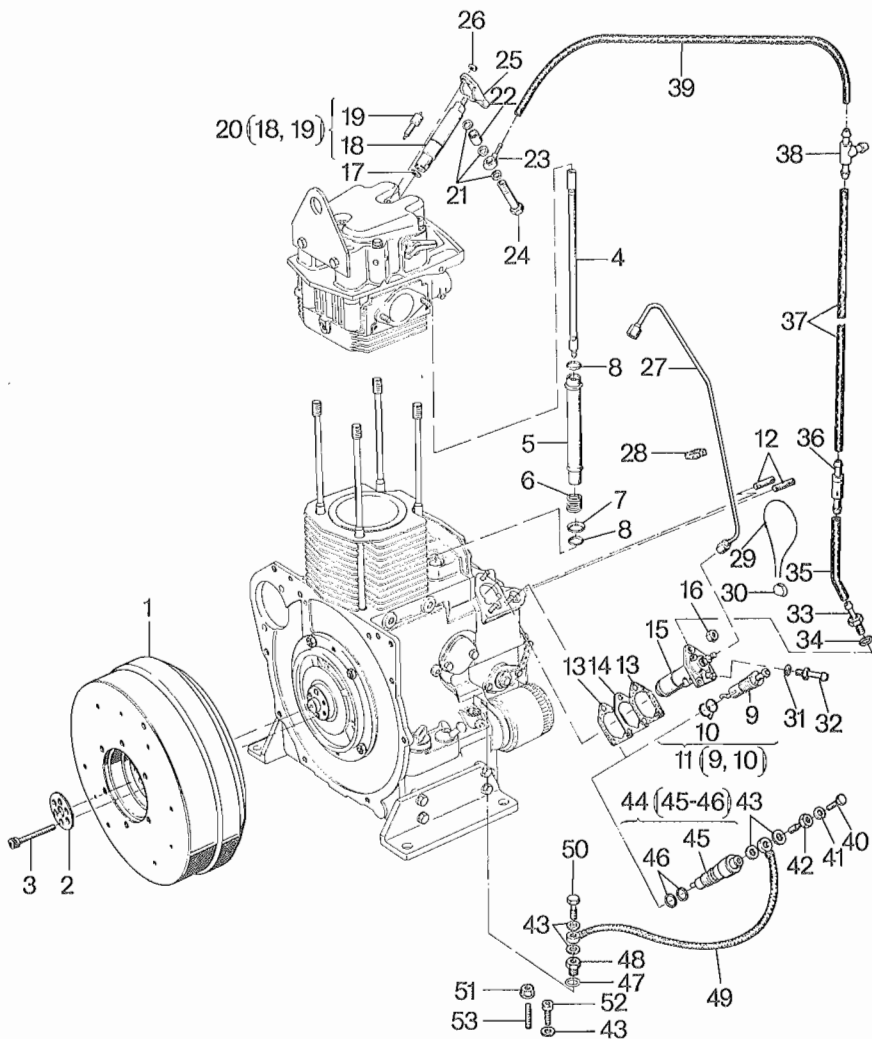

Fig. No.	Bestell-Nr. Ordering No. No. référence No. de pedido	Stück Quantity Quantités Cantidades	Hinweise Hints Indications Indicaciones
1	033 617 10	1	
2	032 169 00	1	
3	500 570 00	6	M 12 x 75 DIN 912 - 12.9
4	006 338 00	2	
5	032 163 00	2	
6	031 851 00	2	
7	031 852 00	2	
8	502 580 00	4	
9	—	—	
10	400 229 00	2	
11	003 416 01	1	
12	031 746 00	2	
13	031 684 00	2	
14	031 683 02	0 ... 1	0,15 mm
14	031 685 01	0 ... 1	0,20 mm
14	031 686 01	0 ... 1	0,25 mm
14	031 687 01	0 ... 1	0,30 mm
15	400 814 10	1	
16	500 229 00	3	M 8 DIN 934 - 8
17	400 558 00	1	
18	—	—	
19	400 827 01	P1 1	
20	400 826 10	1	
21	500 009 00	3	A 8 x 11,5 DIN 7603 - Cu
22	032 929 00	1	
23	500 157 00	1	
24	032 928 00	1	
25	033 931 00	1	
26	500 227 00	P3 3	M 6 DIN 934 - 8
27	006 137 10	1	
28	031 509 00	1	
29	400 215 00	1	
30	400 214 00	1	
31	500 011 00	1	A 12 x 15,5 DIN 7603 - Cu
32	034 850 00	1	
33	036 629 00	1	

M 14

Einspritzausrstung
Injection equipment
Equipement d'injection
Equipo de inyeccin

M 17

Schwungrad
Flywheel
Volant
Volante

Tafel Nr.
Tabl. No.

09

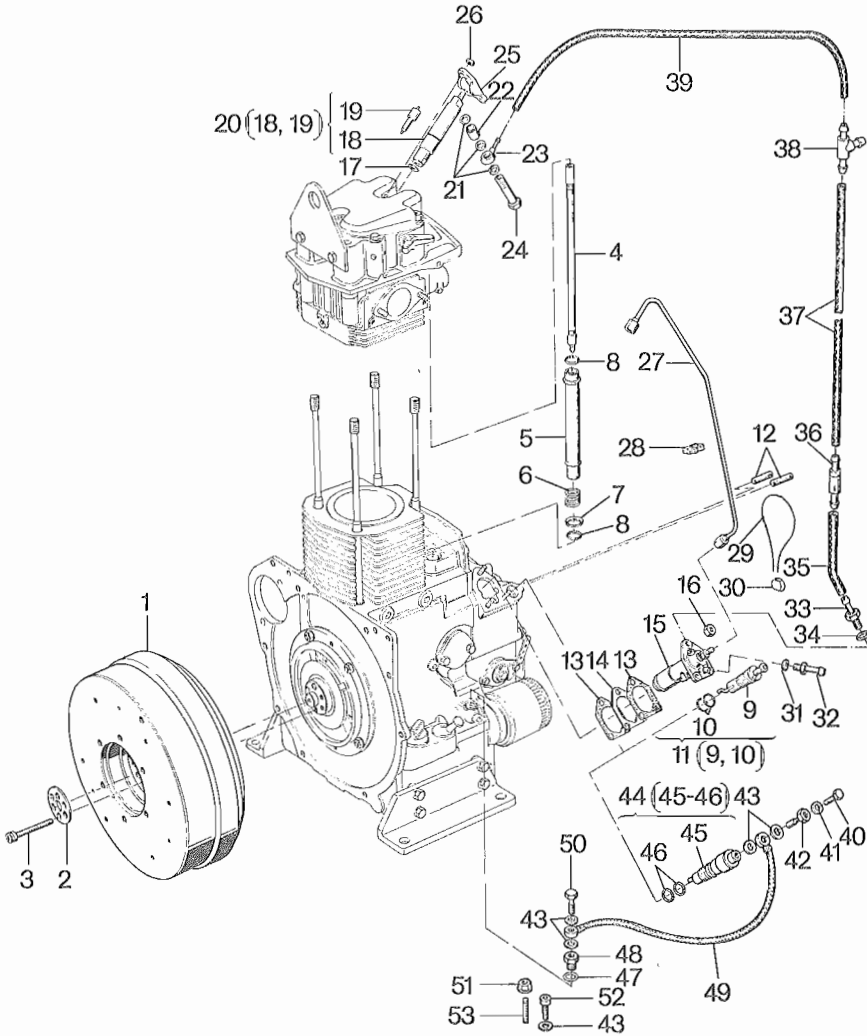

Fig. No.	Bestell-Nr. Ordering No. No. référence No. de pedido	Stück Quantity Quantités Cantidades	Hinweise Hints Indications Indicaciones
34	500 008 00	1	A 6,5 x 9,5 DIN 7603 - Cu
35	036 637 00	1	4,5 x 2,5 - 50 mm
36	008 055 00	P1 1	
37	038 071 00	1	4,5 x 2,5 - 150 mm
38	501 578 00	1	
39	036 642 00	1	4,5 x 2,5 - 130 mm
40	500 253 00	1	M 6 x 8 DIN 933 - 8.8
41	500 008 00	1	A 6,5 x 9,5 DIN 7603 - Cu
42	037 248 00	1	
43	500 009 00	5	A 8 x 11,5 DIN 7603 - Cu
44	008 510 00	1	
45	—	—	
46	501 691 00	2	
47	500 624 00	1	A 10 x 13,5 DIN 7603 - Cu
48	037 184 00	1	
49	010 068 00	1	
50	500 061 00	1	A 2/3 DIN 7623 Zn
51	501 836 00	1	M 8 SEAL - LOCK
52	037 016 00	1	
53	036 574 00	1	

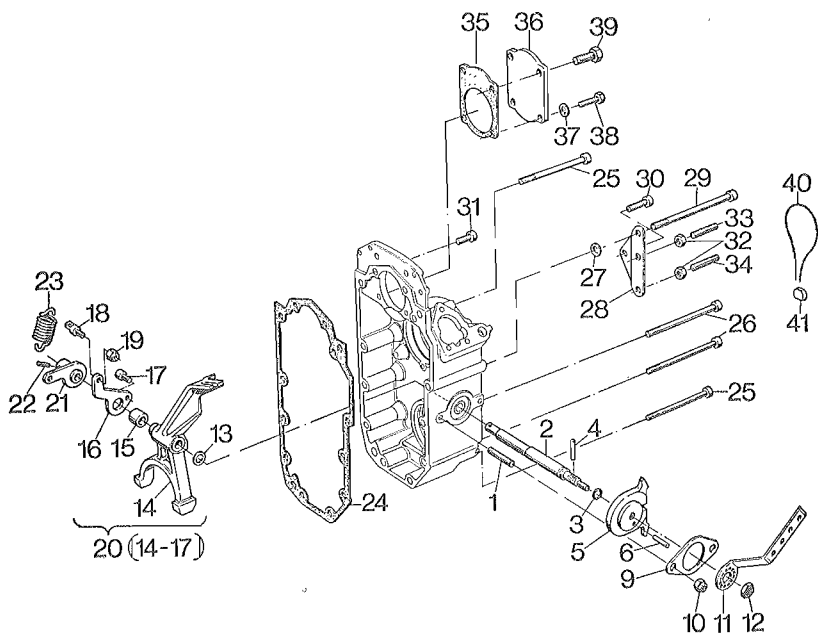

Fig. No.	Bestell-Nr. Ordering No. No. référence No. de pedido	Stück Quantity Quantités Cantidades	Hinweise Hints Indications Indicaciones
1	500 374 00	2	M 8 x 18 DIN 939 - 5.6
2	034 013 20	1	
3	502 481 00	1	
4	500 341 00	1	3 x 16 DIN 1481
5	034 314 10	1	
6	501 366 00	1	4 x 12 DIN 7344
7	—	—	
8	—	—	
9	032 126 00	1	
10	400 284 00	2	M 8 SSN 440 - 8 Cu
11	034 029 00	1	
12	400 835 00	1	M 8 SSN 003 - 04 Zn
13	035 649 00	1	
14	—	—	
15	502 130 00	2	
16	036 363 00	1	
17	500 506 00	1	M 6 x 12 DIN 912 - 8.8
18	036 365 00	1	
19	400 283 00	1	M 6 SSN 440 - 8 Cu
20	009 409 00	1	
21	009 422 00	1	
22	501 320 00	1	4 x 16 DIN 1481
23	035 000 10	1	2,7 mm ϕ
24	033 921 00	1	
25	500 532 00	4	M 8 x 80 DIN 912 - 8.8
26	500 597 00	4	M 8 x 100 DIN 912 - 8.8
27	031 332 00	1	
28	033 693 00	1	
29	500 648 00	2	M 8 x 120 DIN 912 - 8.8
30	500 516 00	1	M 8 x 16 DIN 912 - 8.8
31	500 519 00	2	M 8 x 20 DIN 912 - 8.8
32	500 229 00	2	M 8 DIN 934 - 8
33	036 574 00	1	
34	031 695 01	1	
35	034 385 00	1	
36	034 384 00	1	

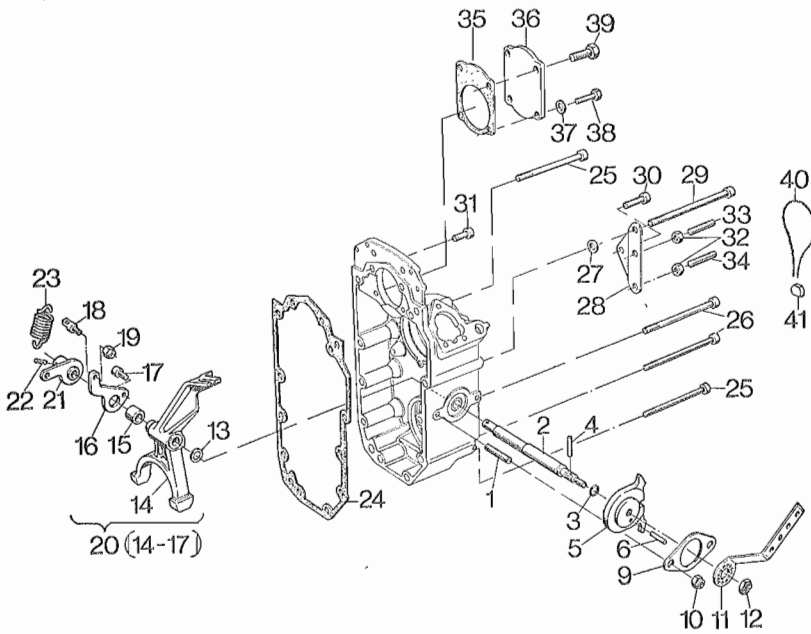

Fig. No.	Bestell-Nr. Ordering No. No. référence No. de pedido	Stück Quantity Quantités Cantidades	Hinweise Hints Indications Indicaciones	
37	500 009 00	2	A 8 x 11,5	DIN 7603 - Cu
38	500 268 00	2	M 8 x 20	DIN 933 - 8.8
39	500 291 00	2	M 10 x 20	DIN 933 - 8.8
40	400 215 00	1		
41	400 214 00	1		

A 01

Kraftstoffbehälter, Filter, Leitungen
Fuel tank, filter, pipes
Reservoir à carburant, filtre, conduites
Depósito combustible, filtro, tubería

Tafel Nr.
Tabl. No.

11

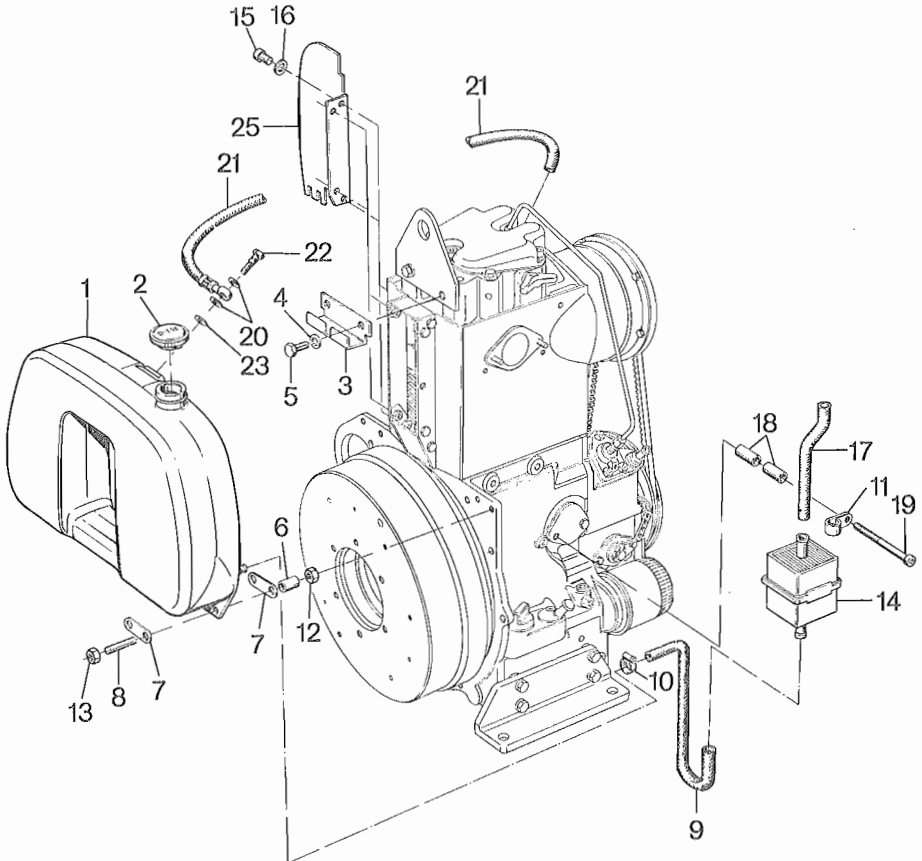

Fig. No.	Bestell-Nr. Ordering No. No. référence No. de pedido	Stück Quantity Quantités Cantidades	Hinweise Hints Indications Indicaciones	
1	007 588 00	1		
2	400 327 00 P1	1		
3	035 257 00	1		
4	500 029 00	2	10	DIN 128
5	500 538 00	2	M 10 x 25	DIN 933-8.8
6	035 206 00	4		
7	035 258 00	4		
8	500 385 00	4	M 8 x 40	DIN 835-5.6
9	035 256 00	1	7,00 x 2,5	- 400 mm
10	400 261 00	1		
11	031 655 00	1		
12	501 480 00	4	M 8	DIN 934-8 Zn
13	400 284 00	4	M 8	SSN 440-8 Cu
14	400 894 01 W2	1		
15	500 166 00	8	6,4	DIN 125 St
16	500 506 00	8	M 6 x 12	DIN 912-8.8
17	035 255 00	1	7,0 x 2,5	- 180 mm
18	032 004 00	2		
19	501 209 00	1	M 8 x 85	DIN 912-8.8
20	500 624 00	2	A 10 x 13,5	DIN 7603 - Cu
21	036 738 00	1	4,5 x 2,5	- 275 mm
22	501 697 00	1	C 4 kadm	DIN 7623
23	501 583 00	1	10,5 Cu	DIN 125

A 02 Luftfilter
Air filter
Filtre à air
Filtro de aire

A 03 Auspuff
Exhaust silencer
Silencieux
Silenciador

A 04 Andrehkurbel
Starting handle
Manivelle
Manivela

Tafel Nr.
Tabl. No.
12

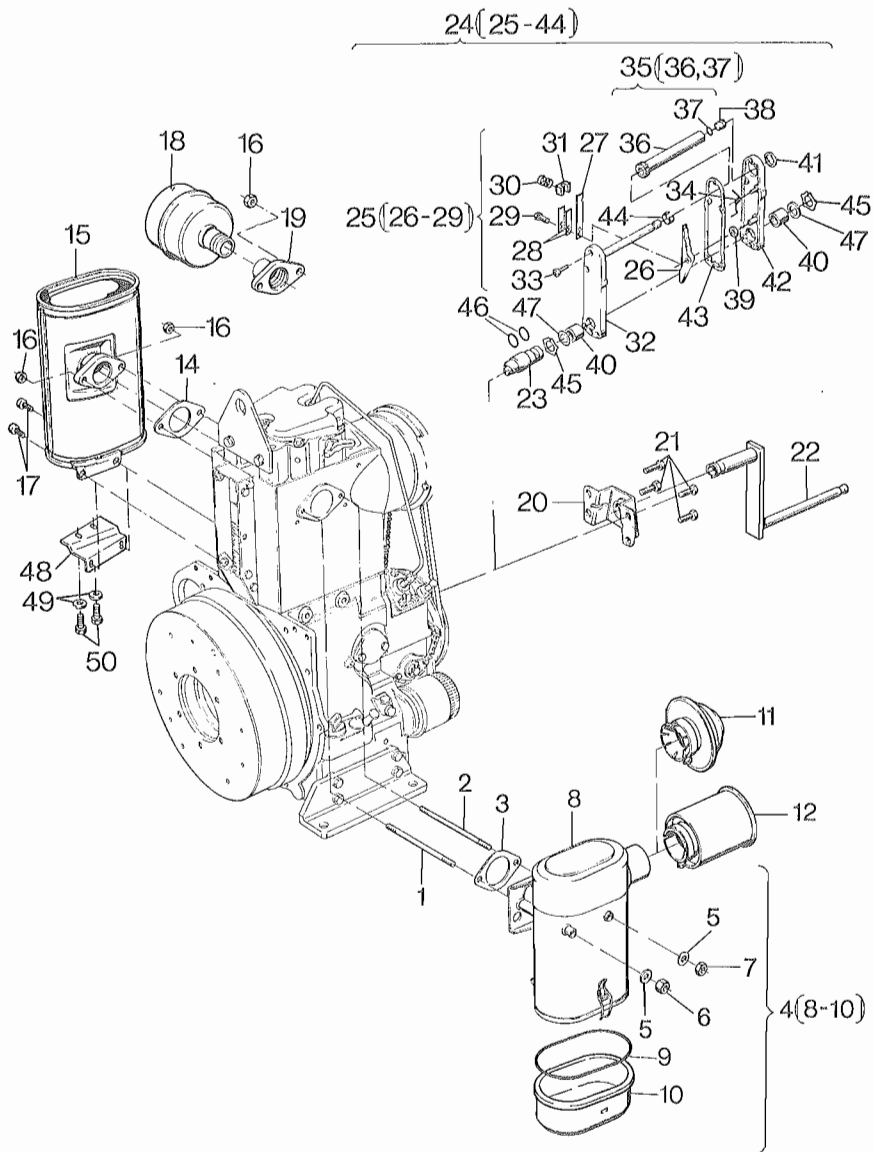

Fig. No.	Bestell-Nr. Ordering No. No. référence No. de pedido	Stück Quantity Quantités Cantidades	Hinweise Hints Indications Indicaciones	
1	501 245 00	1	M 8 x 150	DIN 835 - 5 D
2	501 272 00	1	M 8 x 155	DIN 835 - 5 D
3	034 767 00 W1	1		
4	008 576 00	1		
5	500 168 00	2	8,4	DIN 125 Ms
6	400 816 00	1		
7	500 230 00	1	M 8 Ms	DIN 934 - Ms
8	---	---		
9	490 377 00 P1	1		
10	490 378 00	1		
11	400 404 00	1		
12	010 359 00	1		
13	---	---		
14	500 023 00	1		
15	008 580 01	1		
16	400 816 00	2	M 8 MS	
17	501 357 00	2	M 10 x 16	DIN 912-8.8A3C
18	008 722 00	1		
19	038 292 00	1		
20	034 879 00	1		
21	501 389 00	4	M 8 x 12	DIN 912-8.8A3C
22	007 261 00	1	107 mm	
22	003 032 02	1	122 mm	
22	003 031 02	1	242 mm	
22	008 637 00	1	320 mm	
23	010 198 00	1	107 mm	
23	010 197 00	1	122 mm	
23	010 200 00	1	242 mm	
24	010 278 02	1	„A“	
25	010 114 03	1		
26	---	---		
27	038 121 02	1		
28	039 171 00	2		
29	503 165 00	2	M 5 x 8	
30	038 184 00	1		
31	038 820 00	1		

A 02 Luftfilter
Air filter
Filtre à air
Filtro de aire

A 03 Auspuff
Exhaust silencer
Silencieux
Silenciador

A 04 Andrehkurbel
Starting handle
Manivelle
Manivela

Tafel Nr.
Tabl. No.
12

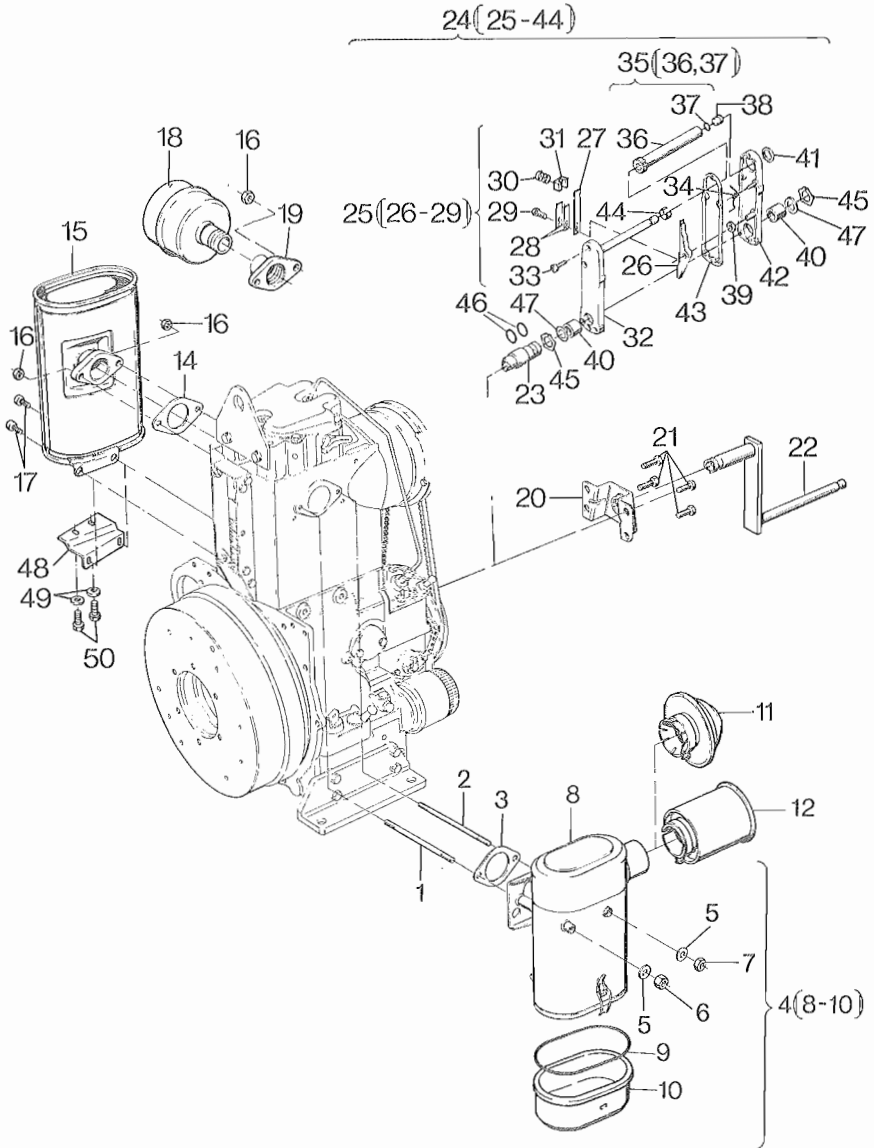

Fig. No.	Bestell-Nr. Ordering No. No. référence No. de pedido	Stück Quantity Quantités Cantidades	Hinweise Hints Indications Indicaciones
32	—	—	
33	501 944 00	5	6 x 25
34	038 784 00	1	„A“
35	010 113 00	1	
36	—	—	
37	501 691 00	1	19 x 1,8
38	501 992 00	1	
39	501 958 00	1	
40	501 934 00	2	
41	501 942 00	1	
42	—	—	
43	038 130 00	1	
44	035 154 00	1	
45	501 943 00	2	A 30 x 1,5 K
46	502 585 00	2	DIN 983
47	039 286 00	2...4	0,15 mm
48	037 398 00	1	
49	500 167 00	2	8,4
50	500 266 00	2	M 8 x 12
			DIN 125 - St
			DIN 933-8.8

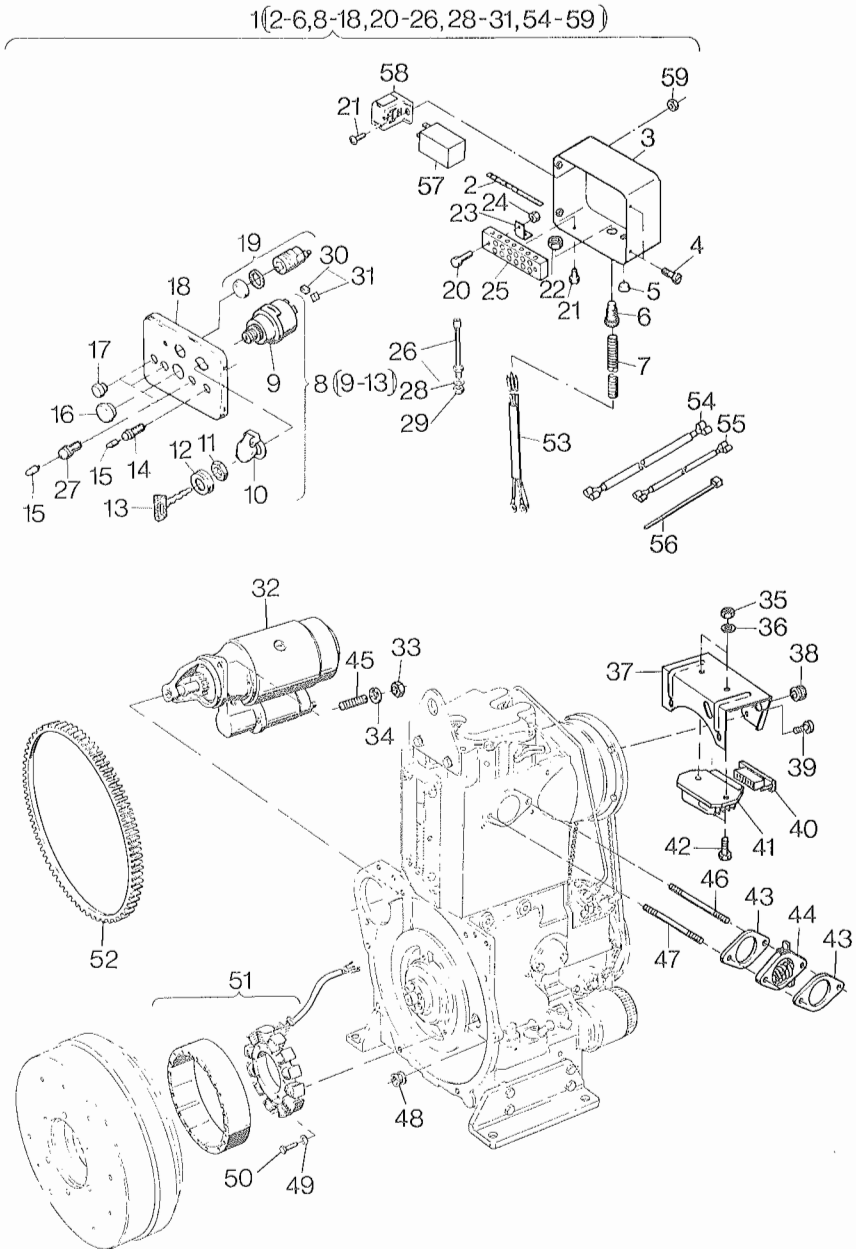

Fig. No.	Bestell-Nr. Ordering No. No. référence No. de pedido	Stück Quantity Quantités Cantidades	Hinweise Hints Indications Indicaciones
1	011 129 01	1	
2	038 862 00	1	
3	007 163 10	1	
4	501 383 00	4	M 6 x 10
5	501 608 00	2	DIN 7985-8.8 Zn
6	501 590 10	1	
7	—	—	
8	502 765 00	1	
9	—	—	
10	490 509 00	1	
11	—	—	
12	—	—	
13	501 664 00	P1 1	
14	501 765 00	1	BATT
15	400 097 00	2	
16	400 914 00	2	24
17	400 960 00	2	
18	035 092 11	1	
19	502 808 00	1	
20	501 588 00	2	M 4 x 20
21	500 493 00	3	5 x 10
			DIN 7985-4.8 Zn
22	501 591 00	1	
23	036 667 00	2	
24	501 471 00	2	M 4
			DIN 934-8 A3C
25	501 607 00	1	
26	008 756 00	1	
27	501 766 00	1	OEL
28	500 168 00	1	8,4
			DIN 125-Ms
29	500 230 00	1	M 8
			DIN 934-Ms
30	502 767 00	1	6 - P
31	502 766 00	1	4 - P
32	400 873 00	1	12 V
			1,9 kW
33	500 936 00	2	M 12
			DIN 934-8 A3C
34	500 632 00	2	12
			DIN 128-A3C
35	400 283 00	2	M 6
			SSN 440-8 Cu
36	501 445 00	2	6,4
			DIN 125-St A3C

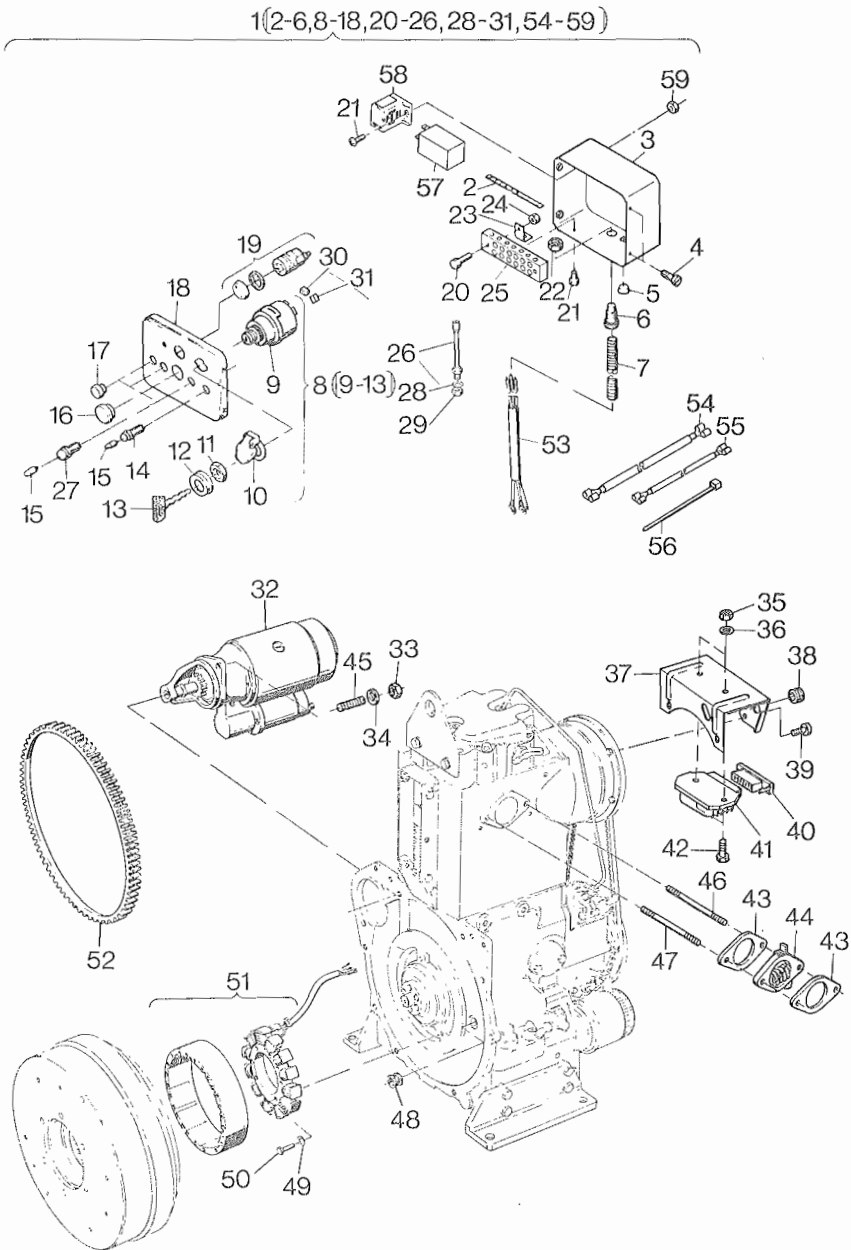

Fig.No.	Bestell-Nr. Ordering No. No. référence No. de pedido	Stück Quantity Quantities Cantidades	Hinweise Hints Indications Indicaciones
37	011 079 00	1	
38	501 587 00	1	
39	500 494 00	2	M 5 x 20 DIN 84-4.8
40	502 839 00	1	
41	502 838 00	1	
42	502 079 00	2	M 6 x 20 DIN 933-8.8 A3C
43	500 023 00	2	40 / 1,2
44	502 807 00	1	12 / 40 MW
45	500 423 00	2	M 12 x 25 DIN 939-5.6 A3C
46	502 810 00	1	M 8 x 170 DIN 835-8.8
47	502 809 00	1	M 8 x 165 DIN 835-8.8
48	400 413 00	1	
49	400 277 00	3	6
50	500 507 00	3	M 6 x 16 DIN 912-8.8
51	502 836 00	1	
52	031 561 01	1	
53	—	—	
54	010 898 00	1	
55	010 899 00	1	
56	400 947 00	1	
57	502 758 01	1	MSR 12 V
58	502 760 00	1	
59	400 282 00	1	M 5

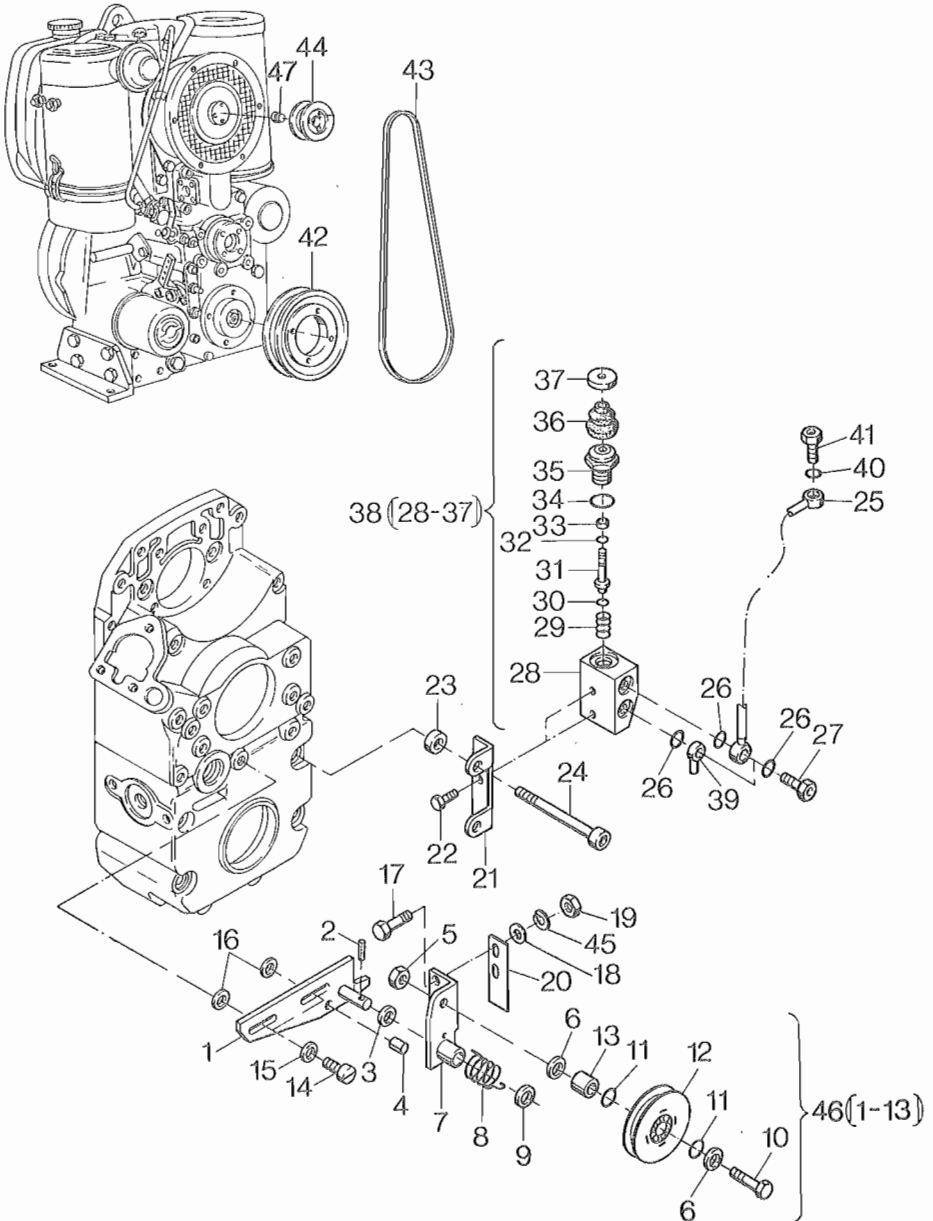

Fig. No.	Bestell-Nr. Ordering No. No. référence No. de pedido	Stück Quantity Quantities Cantidades	Hinweise Hints Indications Indicaciones
1	010 371 01	1	
2	500 347 00	1	4 x 22
3	037 256 00	1	10 x 15 x 1
4	500 849 00	1	8 x 12
5	400 835 00	1	M 8
6	038 408 00	2	12 x 18 x 2,5
7	010 372 00	1	
8	034 679 00	1	
9	039 266 00	1	16 x 11 x 8
10	500 270 00	1	M 8 x 25
11	502 534 00	2	6201 ZAV
12	010 390 00	1	
13	038 300 00	1	8,4 x 12 x 14
14	500 521 00	2	M 8 x 25
15	501 481 00	2	8,4
16	501 230 00	2	8,4
17	500 252 00	2	M 5 x 16
18	502 163 00	2	5,3
19	500 943 00	2	M 5
20	038 675 00	1	
21	038 672 00	1	
22	500 251 00	2	M 5 x 10
23	039 058 00	2	9 x 14 x 3,5
24	502 068 00	2	M 8 x 105
25	010 691 00	1	
26	500 624 00	4	A 10 x 13,5
27	500 062 00	2	A 4
28	038 193 01	1	
29	036 178 00	1	
30	036 913 00	1	
31	038 196 01	1	
32	400 220 00	1	5 x 2
33	502 494 00	1	
34	500 013 00	1	16 x 22
35	038 194 00	1	
36	502 489 00	1	

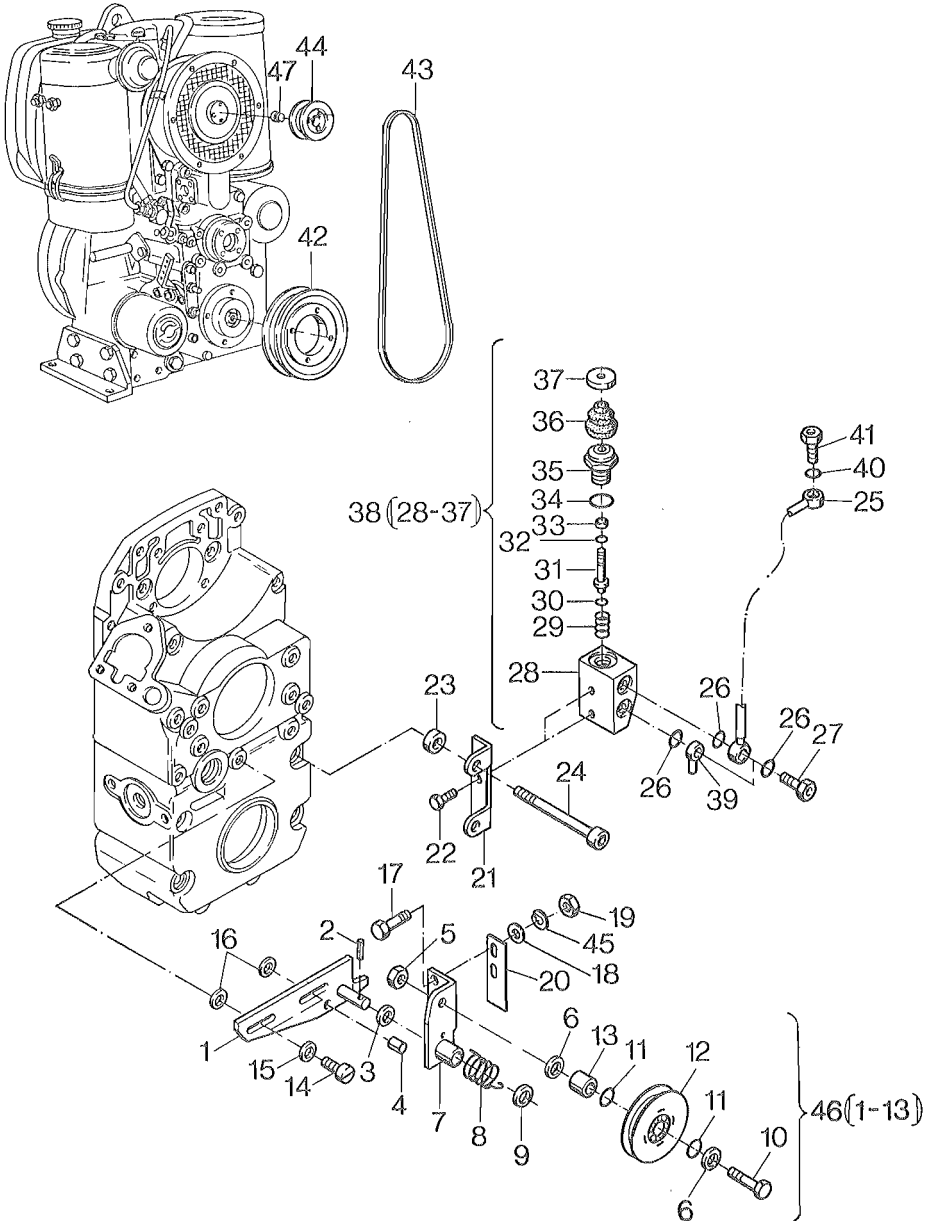

Fig. No.	Bestell-Nr. Ordering No. No. référence No. de pedido	Stück Quantity Quantities Cantidades	Hinweise Hints Indications Indicaciones
37	038 674 00	1	
38	010 182 01	1	
39	400 926 00	1	NW 4/6
40	500 011 00	1	A 12 x 15,5
41	500 063 00	1	A 6
42	038 540 00	1	
43	502 850 00	1	FO-Z
44	038 541 00	1	
45	500 026 00	2	5
46	009 227 11	1	
47	039 076 00	1	

A 10

Kraftstoffabsperrentil
Shut-off valve
Soupape d'arrêt
Válvula cierre

Tafel Nr.
Tabl. No.

15

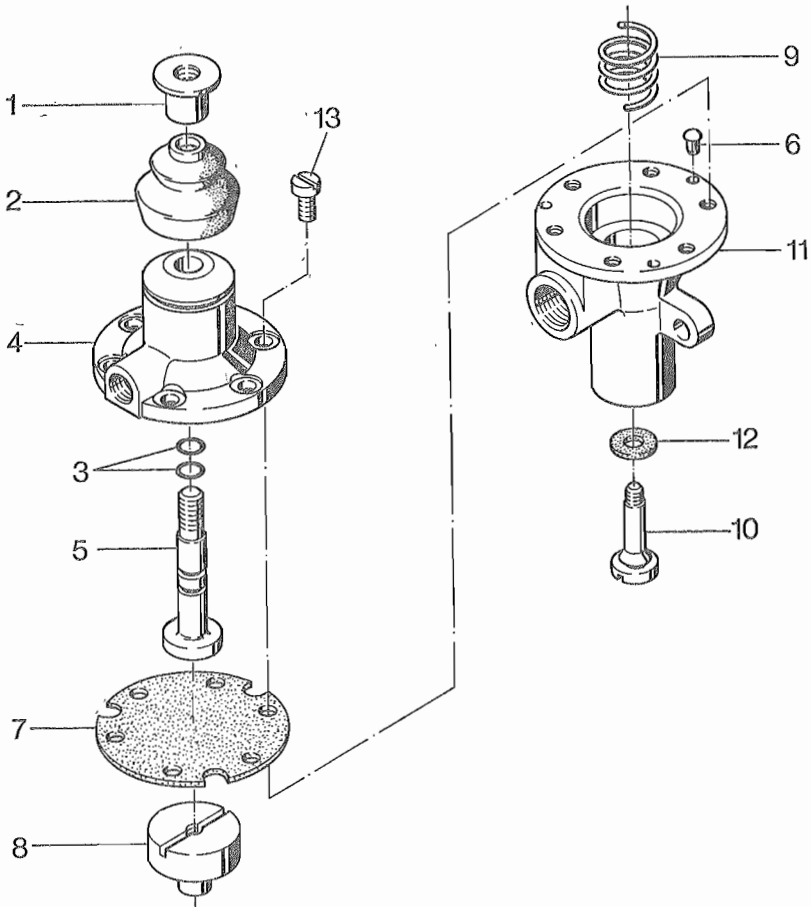

Fig. No.	Bestell-Nr. Ordering No. No. référence No. de pedido	Stück Quantity Quantites Cantidades	Hinweise Hints Indications Indicaciones
1	035 359 00	1	
2	502 489 00	1	
3	501 670 00	2	
4	036 922 00	1	
5	036 920 00	1	
6	—	—	
7	036 921 00	1	
8	036 918 00	1	
9	036 914 00	1	
10	036 912 00	1	
11	036 923 00	1	
12	036 913 00	1	
13	500 492 00	6	M 4 x 10 DIN 84-4.8 A3C

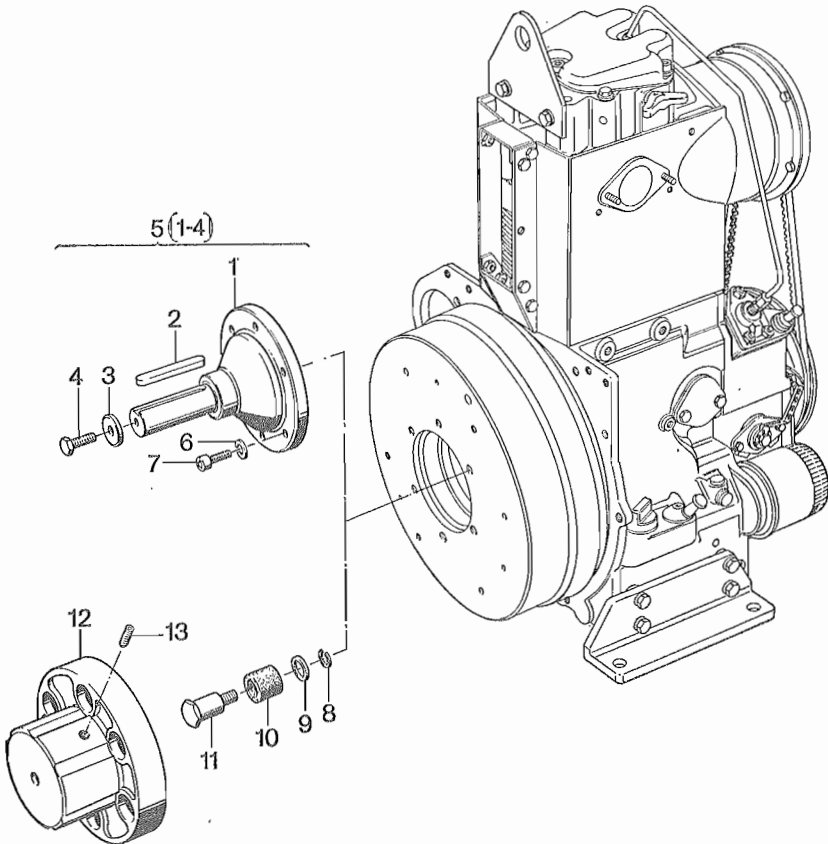

Fig. No.	Bestell-Nr. Ordering No. No. référence No. de pedido	Stück Quantity Quantities Cantidades	Hinweise Hints Indications Indicaciones
1	—	—	
2	500 626 00	1	A 14 x 9 x 100 DIN 6885
3	032 867 00	1	
4	500 313 00	1	M 12 x 35 DIN 933 - 8.8
5	003 491 02	1	
6	500 030 00	6	12 DIN 128
7	500 563 00	6	M 12 x 30 DIN 912 - 8.8
8	500 616 00	6	12 DIN 7980
9	030 790 00	6	
10	031 510 00	6	
11	030 469 00	6	
12	030 405 00	1	
13	500 046 00	1	AM 8 x 15 DIN 916-45 H

Anhang für nicht abgebildete Zusatzausrüstung

Weitere Zusatzausrüstungen können aus Platzgründen in der Ersatzteilliste nicht mehr detailliert dargestellt werden. Für die Bestellung von Teilen aus nicht abgebildeten Zusatzausrüstungen verwenden Sie bitte nachfolgende Übersicht. Anhand der Skizze ist die gesuchte Zusatzausrüstung auffindbar, die für den jeweiligen Motortyp zugehörige Ident-Nr. der Ausrüstung ist aus der Tabelle ersichtlich. Ihre zuständige HATZ-Vertretung kann Ihnen anhand dieser Ident-Nr. das gewünschte Ersatzteil heraussuchen.

Annex for additional equipment which is not illustrated

Due to lack of space we cannot list further additional equipment in our parts list. For parts ordering not illustrated, please use the below listed survey. With the aid of sketches you can find the required additional equipment. The ident-number belonging to the corresponding engine type can be taken from the table. Your HATZ agent is in a position to select for you the required spare part as soon as you have selected the correct ident-number.

Annexe concernant les accessoires complémentaires non-illustrés

Un certain nombre d'accessoires complémentaires n'ont pu, par suite d'un manque de place, être représentés d'une manière détaillée dans la liste de pièces détachées. Pour la commande de ces accessoires, qui ne sont pas illustrés, veuillez utiliser l'aperçu ci-après. A l'aide des croquis, il est possible de trouver l'accessoire souhaité, le No. ident. correspondant pour chaque type de moteur figure dans le tableau. Grâce à ce No. ident. votre représentant HATZ pourra vous trouver la pièce souhaitée.

En relación a equipos adicionales no ilustrados

Debido a razones de espacio no es posible ilustrar otros equipos adicionales en la lista de piezas. Para pedidos de equipos adicionales no ilustrados favor usen la siguiente orientación. A base de las ilustraciones es posible encontrar el equipo adicional buscado, el número ident para el tipo de motor para el cual se necesita el equipo se puede obtener de la tabla.

El representante HATZ para su area puede entonces a base del número ident encontrar las piezas deseadas.

Zusatzausrüstungen
Equipements
Accessoires complémentaires
Equipos

Hinweise
Hints
Indications
Indications

Code Ident-Nr.



A 07.40 008 391 01



A 09.40 007 591 00



A 10.20 008 902 00





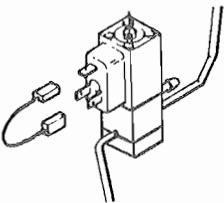

A 10.70 008 867 00

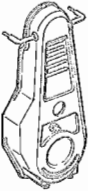

A 11.10 010 877 00

Zusatzausrüstungen
Equipements
Accessoires complémentaires
Equipos

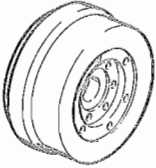
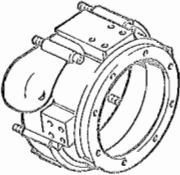
Hinweise
 Hints
 Indications
 Indications

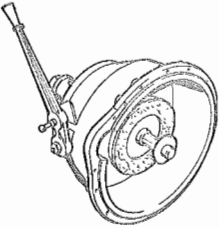
	Code	Ident-Nr.	
	A 12.10	006 966 02	
	A 12.30	007 900 00	
	A 14.10	007 118 02	
	A 15.20	007 117 00	SAE 6
	A 15.20	008 249 00	SAE 5
	A 16.40	005 082 00	∅ 260
	A 16.40	005 083 00	∅ 240
	A 16.40	005 084 00	∅ 220
	A 16.40	005 085 00	∅ 200
	A 17.11	005 927 00	

**Zusatzausrüstungen
Equipements**

**Accessoires complémentaires
Equipos**

Hinweise
Hints
Indications
Indicaciones

Code Ident-Nr.

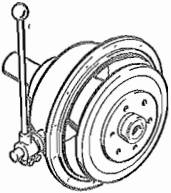

A 17.21 007 254 02



A 17.30 003 875 00

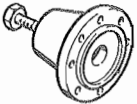

A 17.50 003 877 01



A 18.10 006 044 00

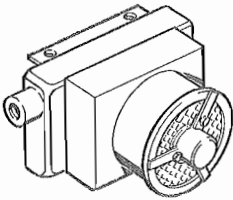

A 18.30 010 049 00

ca. 5 kW
12 V, 6 A

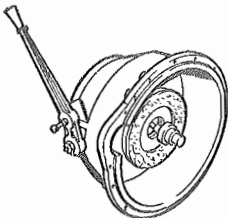

A 20.60 007 577 01

Änderungsübersicht E 950
Modification table E 950
Aperçu de modifications E 950
Tabla de modificaciones E 950

Bildtafel	Pos. No.	Bestell-Nr.	Stück	Bildtafel	Pos. No.	Bestell-Nr.	Stück	IMT NO.	
Table	Fig. No.	Ordering No.	Qty.	Table	Fig. No.	Ordering No.	Qty.		
Planche	Fig. No.	No. référence	Qté.	Planche	Fig. No.	No. référence	Qté.		
Tabla	Fig. No.	No. de pedido	Cant.	Tabla	Fig. No.	No. de pedido	Cant.		
E 950.17				E 950.18				87.463	
08	15	—	1	07	15	034 589 10	1		
08	16	007 314 05	1	07	16	007 314 06	1		
08	34	033 657 00	1	07	34	033 657 10	1		
08	36	034 459 01	1	07	36	034 459 10	1		
08	43	007 315 02	1	07	43	007 315 10	1		
08	55	007 438 01	1	07	55	007 438 10	1		
—	—	—	—	07	63	037 784 00	1		