

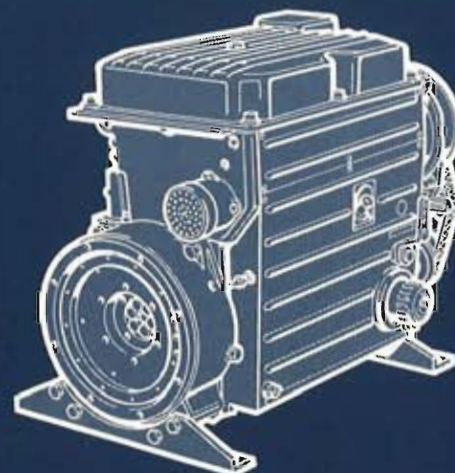

MOTORENFABRIK HATZ GMBH & CO KG · D-8399 RUHSTORF a. d. ROTT
TEL. (08531) 30 21 · TELEX 5 7260

Ersatzteil-Liste
Spare parts list
Liste des pièces de rechange
Lista de recambios



2...4L31S
2...4L31Z
2...4L40S
2...4L40Z

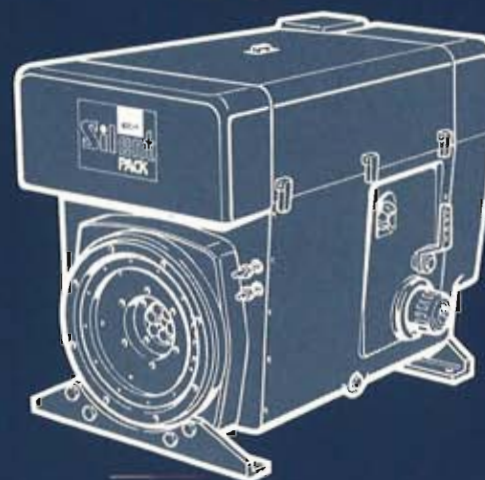

2...4L31C
4L31K
2...4L40C
4L40K

WICHTIG – Bitte Daten eintragen
IMPORTANT – Compléter les données

IMPORTANT – Please enter data
IMPORTANTE – Favor completar datos

1.

Bitte hier **Type**, **Motornummer** und **Drehzahl** (siehe Motor-Typenschild) eintragen.

Enter here **type engine no.** and **rpm.** (see engine type-plate).

Indiquer ici le **type**, **N° de moteur** et **régime** (voir plaque signalétique).

Insertar aquí **tipo- N° motor** y **r.p.m.** (vea placa del motor).



2.

Bitte **Ersatzteillistennummer** (siehe Titelseite) gemäß Type ankreuzen, z. B. Typ 4 L 31:

4 L 31.11

Mark spare parts list no. (see title-page) acc. to type, e.g. for type 4 L 31:

4 L 31.11

Cocher le N° de liste de pièces de rechange (voir: couverture) selon type, par. ex. 4 L 31:

4 L 31.11

Marcar N° lista de recambios (ver: frontispició) de acuerdo aipo, ejemplo tipo 4 L 31:

4 L 31.11



Ersatzteilliste Nr.

Spare parts list no.

Liste des pièces de rechange no.

Lista de recambios no.

2 L 31.11 3 L 31.11 4 L 31.11

2 L 40.18 3 L 40.17 4 L 40.17

2

3.

Bitte tragen Sie hier die **Anschrift** Ihrer nächsten HATZ-Service-stelle ein.

Insert here **address** of your next HATZ Service station.

Indiquer ici l'**adresse** de votre stationservice HATZ la plus proche.

Insertar aquí **dirección** de servicio HATZ más cercano.



HATZ-Service

3

MOTORENFABRIK HATZ
GmbH & Co. KG
D - 8399 RUHSTORF a. d. ROTT
Federal Republic of Germany
☎ (085 31) 30 21 – ☒ 5 7260

Angaben bei Ersatzteilbestellungen:

Zur richtigen und schnellen Belieferung mit Ersatzteilen sind folgende Angaben erforderlich:

1. **Type, Motornummer** und **Drehzahl** des Motors, für den das Ersatzteil benötigt wird: siehe Angaben auf Seite 1, Feld 1.
2. **Nummer der Ersatzteilliste**, aus der die Bestellnummer herausgelesen wurde: siehe Seite 1, Feld 2.
3. **Stückzahl** und **Bestell-Nr.** des gewünschten Ersatzteils.
4. Gewünschte **Versandart**, z. B. Post, Luftfracht, Express.
5. Genaue **Versandadresse**, wenn erforderlich mit Post- u. Bahnstation.

Bestellbeispiel:

Für Motortype: 4 L31 C - 154b
Motornummer: 7011870212
min⁻¹: 3000/60

aus Ersatzteil-Liste 4 L31.11

folgende Teile:

Stück	Bestell-Nr.
2	500 526 00
8	500 812 00

per Postexpress an ...

Die Ersatzteilbestellung richten Sie bitte an:

— die nächste HATZ-Servicestelle, Anschrift siehe Seite 1, Feld 3 oder separates Servicestellenverzeichnis

— oder an die

Motorenfabrik Hatz GmbH & Co. KG
D - 8399 Ruhstorf a. d. Rott
Federal Republic of Germany
☎ (085 31) 3021 — ☎ 57260

Particulars for spare parts orders:

The following information is needed to ensure correct and prompt supply of spare parts:

1. **Engine type, engine number** and **r.p.m.** of the engine for which you need the spare part.
See particulars on page 1, field 1.
2. **Number of spare parts list** from which you took the ordering no., see page 1, field 2.
3. **Quantity** and **ordering no.** of requested spare part.
4. Requested **mode of dispatch**, e. g. surface/airmail, airfreight, express.
5. Exact **shipping address**, if necessary indicate local post office and/or railway station.

Example for your order:

For engine type: 4 L31 C - 154b
Engine number: 7011870212
R. p. m.: 3000/60

Spare parts list no. 4 L31.11

The following parts:

Qty.	ordering-no.
2	500 526 00
8	500 812 00

to be mailed, express, to ...

Please address your spare parts order to:

— your nearest HATZ service station, address see page 1, field 3 or separate HATZ-service-list.

— or to

Motorenfabrik Hatz GmbH & Co. KG
D - 8399 Ruhstorf a. d. Rott
Federal Republic of Germany
☎ (085 31) 3021 — ☎ 57260

Données à indiquer lors de vos commandes de pièces détachées:

Pour nous permettre de livrer vos pièces rapidement et correctement, nous avons besoin des données suivantes:

1. **Type, No. et régime du moteur** pour lequel vous avez besoin de pièces: voir données page 1, carré 1.
2. **No de la liste de pièces de rechange** dans laquelle figure le No. de commande: voir page 1, carré 2.
3. **Quantité et No. de commande** de la pièce souhaitée.
4. **Mode d'expédition** souhaitée: par ex. par poste, fret aérien, exprès.
5. **Adresse exacte de destination** et, lorsque ceci est nécessaire, le nom de la poste ou de la gare, ou aéroport.

Exemple:

Pour type de moteur: 4 L31 C - 154b
No. moteur: 7011870212
Régime: 3000/60

Liste de pièces de rechange: 4 L31.11

Les pièces suivantes:

Qté	No. commande
2	500 526 00
8	500 812 00

par poste exprès à ...

Les commandes de pièces détachées sont à adresser à:

— votre station-service HATZ la plus proche, voir adresse page 1, carré 3 ou liste de service séparée.

— ou

Motorenfabrik Hatz GmbH & Co. KG
D - 8399 Ruhstorf a. d. Rott
République Fédérale d'Allemagne
☎ (085 31) 3021 — ☒ 57260

Datos para pedidos de recambios:

Para recibir sus recambios en forma rápida y correcta necesitamos las siguientes informaciones:

1. **Tipo, número del motor y revoluciones:**
ver detalles en página 1, posición 1.
2. **Número de la lista de recambios** de la cual se ha obtenido el número de pedido: ver página 1, posición 2.
3. **Cantidad y número de pedido del recambio deseado.**
4. Tipo de **despacho deseado:** por ej. correo, flete aereo, expreso etc.
5. **Dirección** exacta, si necesario indicar la oficina de correo, la estación ferrocarril o aeropuerto.

Ejemplo de pedido:

Para motor tipo: 4 L31 C - 154b
Número de motor: 7011870212
R. P. M.: 3000/60

De la lista de recambios: 4 L31.11

Siguientes recambios:

Cantidad	Número de pedido
2	500 526 00
8	500 812 00

Por correo expreso a ...

El pedido de recambios favor dirigirlo a:

— Alservicio HATZ más cercano, dirección verla en página 1, posición 3 o en el índice separado de direcciones de servicio.

— Alternativa a:

Motorenfabrik Hatz GmbH & Co. KG
D - 8399 Ruhstorf a. d. Rott
República Federal de Alemania
☎ (085 31) 3021 — ☒ 57260

Inhaltsverzeichnis:		Index:	
M...	Grundmotor	Basic engine	
00, 34	Ersatzteilsätze, Zubehör	Spare part kits, accessories	01
01	Kurbelgehäuse	Crankcase	02+03
01	Massenausgleich	Compensation of masses	04
02, 03	Kurbelwelle	Crankshaft	05
04	Nockenw., Regler, Spritzversteller	Camshaft, governor, timer	06
04	Drehzahlverstellung	Speed control	07
05, 06	Kolben, Pleuelstange, Zylinder	Piston, conrod, cylinder	08
07	Zylinderkopf	Cylinder head	09
09, 10	Stoßstange, Ölpumpe	Pushrod, oil pump	10
11	Steuerdeckel	Timing cover	11
12	Startfüllung	Extra fuel device	12
13	Gebälse	Blower	13
14	Einspritzausrüstung	Injection equipment	14
16, 17 20	Riemenscheibe, Schwungrad, Hydr. Abstellvorrichtung	Pulley, flywheel, hydr. belt tensioner	15
22, 27	Luftfilter, Luftansaugrohr	Air filter, air intake manifold	16
26	Luftführung	Air ducting	17
26	Luftführung S/Z	Air ducting S/Z	18
26	Luftführung	Air ducting	19
35	Kapsel C	Capsule C	20+23
35	Kapsel - Abluftschacht 2-3 L... C	Capsule - air ducting 2-3 L... C	21
35	Kapsel - Abluftschacht 4 L... C/K	Capsule - air ducting 4 L... C/K	22
A...	Zusatzausrüstung	Equipments	
01	Kraftstoff	Fuel	24
03	Auspuff S/Z	Exhaust S/Z	25
03	Auspuff C	Exhaust C	26
04	Startfreigabe	Start release device	27
05	Starter, Generator	Starter, alternator	28
05, 10	Armaturenkasten	Instrument box	29
05, 10	Armaturen, Leitungen	El. equipment, wirings	30
06, 12 15	Motorfüße, Keilriemenschutz, Anschlußgehäuse	Engine brackets, V-belt guard, intermediate housing	31
07	Ölkühler, Ölwanne	Oil cooler, oil sump	32
18	Steuerdeckel f. Hydraulik	Timing cover hydr.	33
	Serien-Nr.-Änderungen	Serial-code modification list	Seite/Page 100

Sommaire:	Indice:	
M...	Moteur de base	Motor de base
00, 34	Jeux de pièces de rechange, accessoires	Juegos de piezas de recambios, accesorios 01
01	Carter moteur	Caja cigueñal 02+03
01	Equilibrage des masses	Compensación de las masas 04
02, 03	Vilebrequin	Cigüeñal 05
04	Arbre à cames, regulateur, variateur d'avance	Arbol de levas, regulador, variador de avance 06
04	Reglage regime	Ajuste de revoluciones 07
05, 06	Piston, bielle, cylindre	Émbolo, biela, cilindro 08
07	Culasse	Culata 09
09, 10	Tige de culbuteur, pompe a huile	Varilla de balancín, bomba de aceite 10
11	Couvercle distribution	Tapa de mando 11
12	Sucharge	Sobre aliment.-arranque 12
13	Soufflerie	Ventilador 13
14	Équipement d'injection	Equipo de inyección 14
16, 17, 20	Poulie, volant, tendeur hydr.	Polea, volante, tensor hidráulico 15
22, 27	Filtre à air, collecteur d'admission	Filtro de aire,tubo de aspiración 16
26	Carter ventilation	Conducción de aire 17
26	Carter ventilation S/Z	Conducción de aire S/Z 18
26	Carter ventilation	Conducción de aire 19
35	Capsule C	Cápsula C 20+23
35	Capsule - carter ventilation 2-3 L... C	Capsula - chapa de aire 2-3 L... C 21
35	Capsule - carter ventilation 4 L... C/K	Capsula - chapa de aire 4 L... C/K 22
A...	Accessoires	Equipos
01	Carburant	Combustible 24
03	Echappement S/Z	Escape S/Z 25
03	Echappement C	Escape C 26
04	Deblocage demarrage	Disparo de arranque 27
05	Demarreur, alternateur	Arrancador, alternador 28
05, 10	Boîtier de bord	Cuadro de mando 29
05, 10	Équipement électrique, cable	Equipo eléctrico, cables 30
06, 12, 15	Pieds moteur, protecteur courroie, Bride raccord,	Soportes del motor, protección corea, caja de conexión 31
07	Radiateur d'huile, carter d'huile	Radiador de aceite, carter de aceite 32
18	Couvercle p. hydr.	Tapa de mando p. hidráulico 33

M 00

Ersatzteilsätze
Spare parts kits
Jeux de pièces de rechange
Juegos de piezas de recambios

M 34

Zubehör
Accessories
Accessoires
Accesorios

Tafel Nr.
Tabl. No.
01

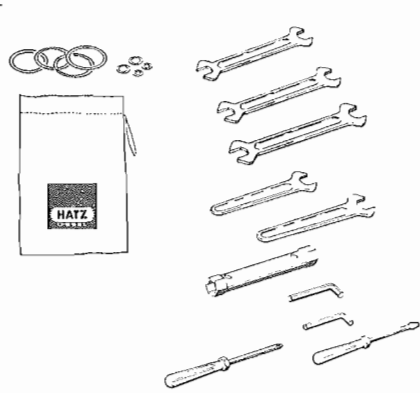
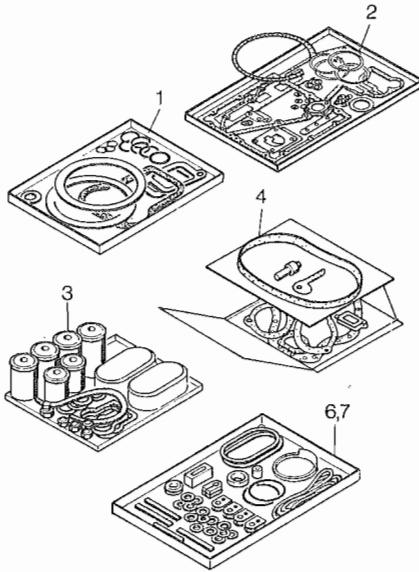

Achtung!
Mitte nur für Gasbetrieb oder
Kapsel betriebers

Attention!
Opérateur ne pas ouvrir
capsule proprement fermée

Attention!
Le silencieux doit être fermé
correctement avant de
prendre en marche le Pack 1
2-3-4-L30C 630/14100

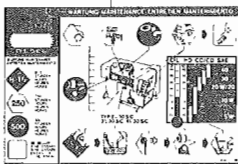

Stop Start — 11

12 — ⊖ 12 Volt ⊕

13 — ⊖ 24 Volt ⊕

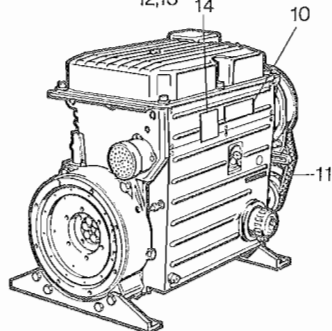
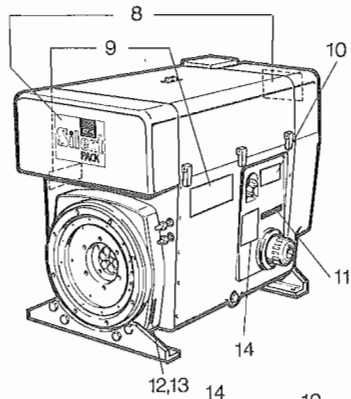
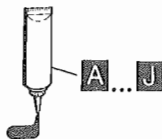

Fig. No.	Bestell-Nr. Ordering No. No. référence No. de pedido	Stück Quantity Quantités Cantidades				Hinweise Hints Indications Indicaciones
----------	---	--	--	--	--	--

2L40S/Z	2L40C 2...3L31	3L40...	4L...
---------	-------------------	---------	-------

P: Im Pannensatz enthalten. — Incl. in emergency kit. — Contenu dans le jeu secour. — Contenido en el juego para averias.
 W: Im Wartungssatz enthalten. — Incl. in maintenance kit. — Contenu dans le jeu d'entretien. — Contenido en el juego de mantenimiento.
 1: Anzahl pro Satz. — Qty. per kit. — Quantite par jeu. — Cantidad por juego.

1	009 922 00 P1	2	2...3	3	4	Dichtungssatz f. 1 Zylinderkopf Gasket set for 1 cyl. head Jeu de joint p. 1 culasse Juego de juntas para 1 culata
2	012 309 00	1	1	1	1	Dichtungssatz Kurbelgehäuse Gasket set crankcase Jeu de joints carter moteur Juego de juntas caja cigueñal
3	009 871 02	1	1	—	—	Wartungssatz für 1000 h 1000 hours maintenance kit
3	009 915 02	—	—	1	—	Kit d'entretien 1000 heures
3	012 033 02	—	—	—	1	Juego de piezas para mantenimiento 1000 horas
4	009 872 02	1	—	1	1	Pannensatz — Emergency kit —
4	012 057 01	—	1	—	—	Kit de secours — Juego para averias
5	009 383 01	1	1	1	1	Zubehörsatz — Accessories kit — Sort. accessoires — Juego de accesorios
6	012 156 00	1	1	1	1	„S/Z“ Gummitellesatz, Rubber comp. set
7	012 157 00	1	1	1	1	„C/K“ Garniture caout., Guarnicion goma
8	036 389 00	—	2	2	2	„C“
9	036 144 00	—	2	2	2	„C“
10	036 317 01	1	1	1	1	
11	033 254 00	1	1	1	1	
12	031 752 00	1	1	1	1	12 V „C/K“
13	036 694 00	1	1	1	1	24 V „C/K“
14	034 306 11	1	1	1	1	

Dicht- und Klebstoffe Sealing- and bonding adhesives		Étanchéifiant et Colle Materias para empaquetar y pegar	
A = 502 230 00	Loctite Activator	—	165 ml
B = 502 231 00	Loctite 573	—	50 ml
C = 502 232 00	Loctite 601	—	50 ml
D = 502 233 00	Loctite 221	—	50 ml
E = 502 234 00	Loctite 648	—	10 ml
F = 502 238 00	Technicol 8058	—	0,750 kg
+ 502 239 00	Technicol 8366	—	0,750 kg
G = 502 565 01	Loctite IS 407	—	20 ml
H = 502 825 00	Silicon	—	75 ml
J = 502 830 00	Hochtemp. Paste	—	100 g

s. Hinweis auf den einzelnen Bildtafeln
 as specified in the individual tables
 suivant les remarques sur les tableaux
 correspondant
 Según las indicaciones de las tablas
 correspondientes

M 01

Kurbelgehäuse
Crankcase
Carter moteur
Caja cigüeñal

Tafel Nr.
Tabl. No.

02

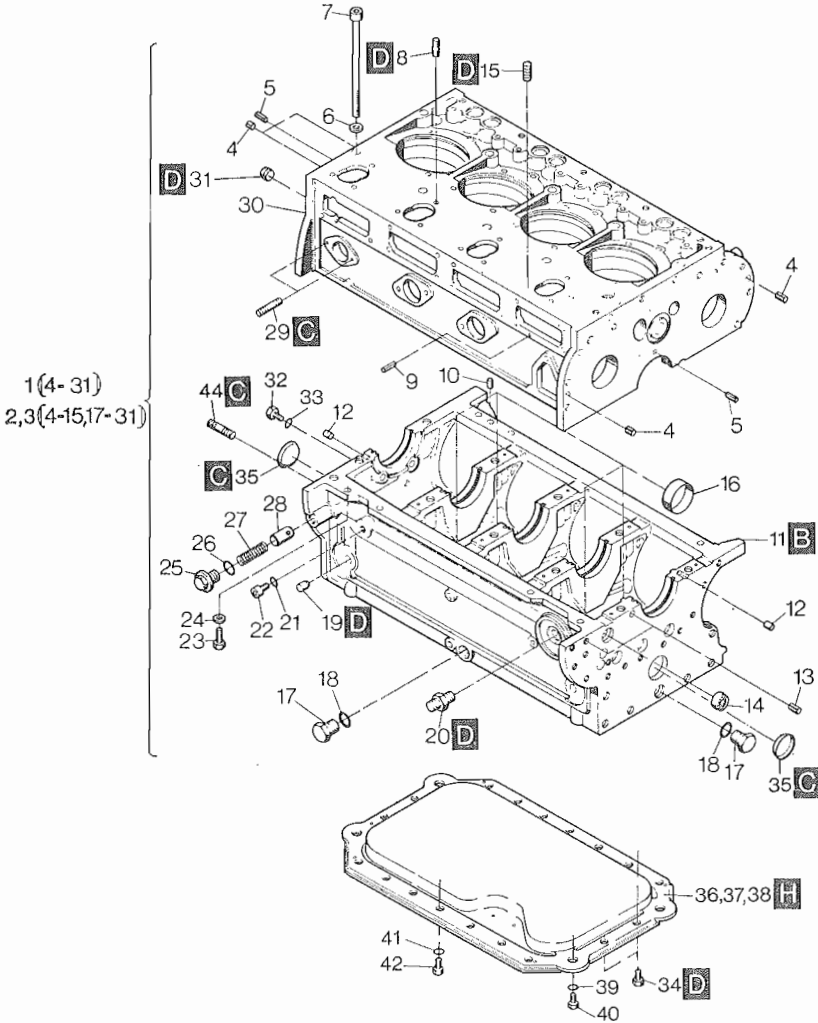

Fig. No.	Bestell-Nr. Ordering No. No. référence No. de pedido	Stück Quantity Quantities Cantidades			Hinweise Hints Indications Indicaciones
		2L...	3L...	4L...	
1	012 009 00	—	—	1	„S/K“
2	009 918 01	—	1	—	
3	009 757 01	1	—	—	
3	012 021 00	—	—	1	„Z/C“
4	501 400 00	4	4	4	8 x 8 DIN 7346
5	501 305 00	2	2	2	5 x 24 DIN 1481
6	034 693 00	6	8	10	
7	501 259 00	6	8	10	M 12x1,5x190 DIN 912-10.9
8	502 908 00	5	8	11	M 8x20 DIN 939-10.9
9	501 305 00	1	1	1	5 x 24 DIN 1481
10	036 353 00	1	1	1	
11	—	—	—	—	
12	501 314 00	2	2	2	10m 6x14 DIN 7-St 50K
13	500 849 00	2	2	2	8 x 12 DIN 7346
14	501 302 00	1	1	1	
15	038 636 00	1	1	1	
16	036 271 00	—	—	4	„S/K“ 48
17	501 404 00 W1	2	2	2	M 22x1,5 DIN 7604-5.8
18	500 016 00 W4	2	2	2	A 22 x 27 DIN 7603-Cu
19	036 457 00	1	1	1	„S/Z“ $n \leq 1500 \text{ min}^{-1}$
20	400 654 00	1	1	1	
21	500 624 00	1	1	1	A 10 x 13,5 DIN 7603-Cu
22	500 623 00	1	1	1	M 10 x 1 DIN 908
23	500 268 00	8	12	17	8 x 20 DIN 933-8.8
24	500 028 00	8	12	17	8 DIN 128
25	032 493 00	1	1	1	
26	500 014 00 W4	1	1	1	A 18 x 22 DIN 7603-Cu
27	036 399 00	1	1	1	
28	036 398 00	1	1	1	
29	501 392 00	2	2	2	M 6 x 16 DIN 939-8.8
30	—	—	—	—	
31	500 438 00	1	1	1	M 14 x 1,5 DIN 906
32	500 265 00	2	2	—	„S“ M8x10 DIN 933-8.8
33	501 629 00	2	2	—	„S“ M8x14 DIN 7603-Cu
34	502 793 00	4	4	—	M 8 x 16 DIN 933-8.8
35	501 408 00	2	2	—	38 DIN 443

M 01

Kurbelgehäuse
Crankcase
Carter moteur
Caja cigueñal

Tafel Nr.
Tabl. No.

02

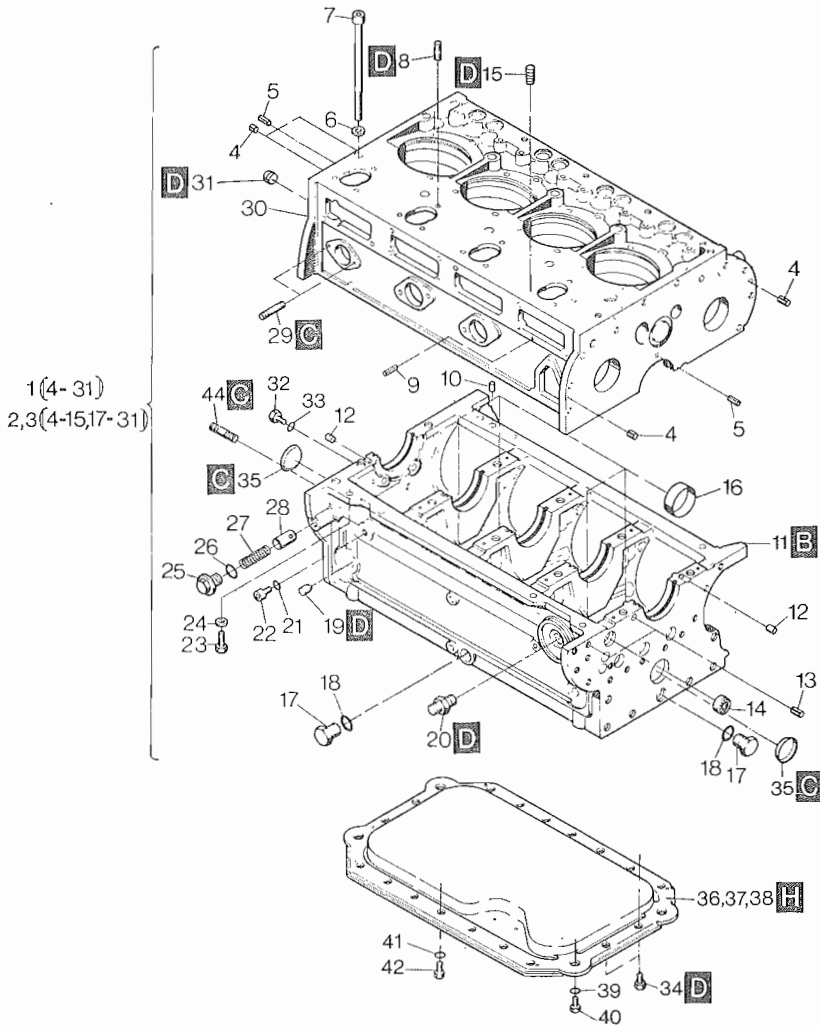

Fig. No.	Bestell-Nr. Ordering No. No. référence No. de pedido	Stück Quantity Quantites Cantidades			Hinweise Hints Indications Indicaciones
		2L...	3L...	4L...	
36	037 526 01	1	—	—	
37	037 527 01	—	1	—	
38	—	—	—	—	s.Taf., Tabl.32, Pos.44
39	500 030 00	4	4	—	12 DIN 128
40	500 806 00	4	4	—	M 12 x 20 DIN 912-8.8
41	500 028 00	8	14	—	8 DIN 128
42	500 267 00	8	14	—	M 8 x 16 DIN 933-8.8
43	502 825 00	1	1	1	
44	502 408 00	2	2	—	„C/Z" M8x12 DIN 938-8.8

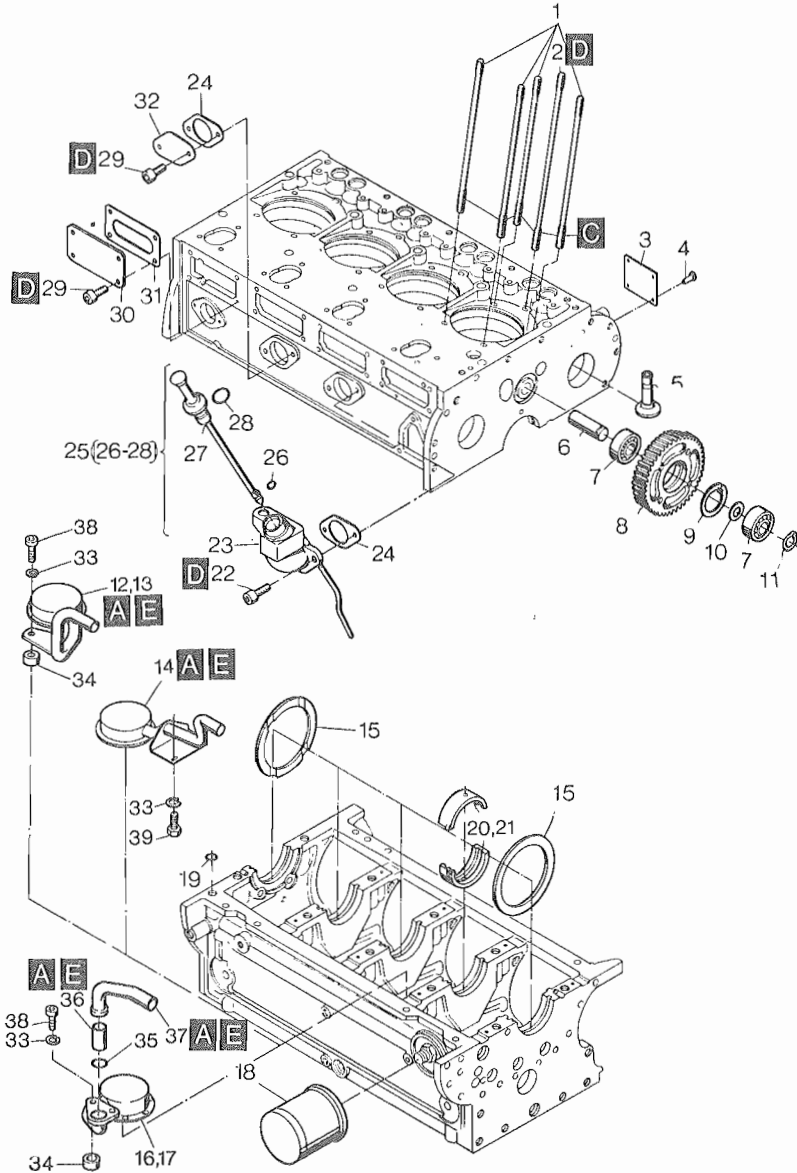

Fig. No.	Bestell-Nr. Ordering No. No. référence No. de pedido	Stück Quantity Quantites Cantidades			Hinweise Hints Indications Indicaciones	
		2L...	3L...	4L...		
1	036 257 02	8	12	16		
2	036 258 02	2	3	4		
3	032 255 03	1	1	1		
4	400 025 00	4	4	4		
5	035 545 01	4	6	8		
6	034 696 01	1	1	1		
7	500 137 00	2	2	2		
8	035 617 02	1	1	1		
9	500 217 00	1	1	1	47 x 1,75	DIN 472
10	034 623 00	1	1	1		
11	501 276 00	1	1	1	20 x 1,75	DIN 471
12	009 293 01	1	—	—		
13	009 294 01	—	1	—		
14	009 292 01	—	—	1	f. Taf./Tabl. 32, Pos. 44	
15	034 633 00	2	2	2		
16	009 290 01	1	—	—	} f. Taf./Tabl. 32, Pos. 42, 43	
17	009 291 01	—	1	—		
18	400 653 00 W4	1	1	1		
19	502 194 00	1	1	1		
20	035 555 00	3	4	5	72 mm ϕ	
21	035 516 00	3	4	5	71,5 mm ϕ	0,5 —
22	500 519 00	2	2	2	M 8 x 20	DIN 912-8.8
23	009 326 01	1	—	—		
23	009 148 03	—	1	1		
24	501 290 00	1	1	2	36	DIN 71511
25	007 397 02	1	1	—	„A“	
25	009 311 00	1	—	—	„C“	} f. Taf./Tabl. 32 Pos. 42, 43, 44
25	009 308 00	—	1	1	„D“	
26	502 025 02	1	1	1		
27	—	—	—	—		
28	501 399 00	1	1	1		
29	501 289 00	4	8	14	M 8 x 16	DIN 912-8.8
30	034 692 00	1	2	3		
31	035 513 00	1	2	3		
32	032 633 00	—	—	1		
33	500 028 00	2	2	2	8	DIN 128

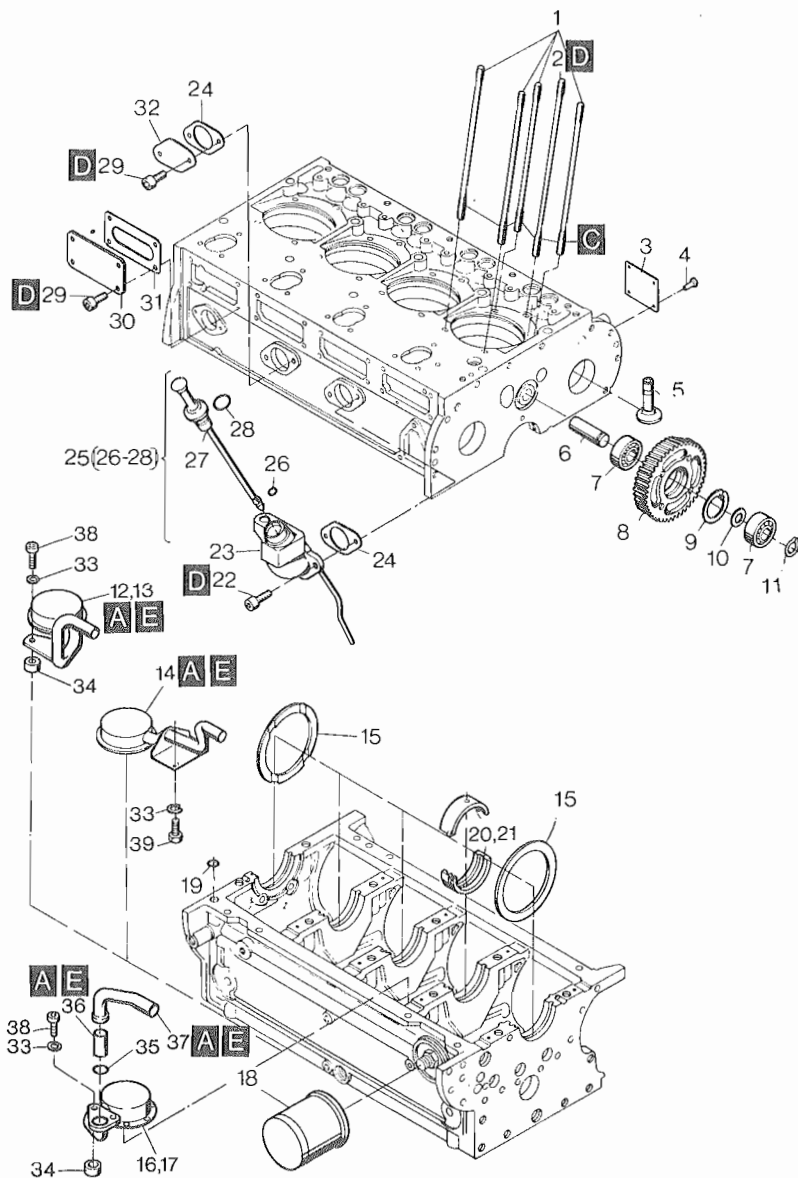

Fig. No.	Bestell-Nr. Ordering No. No. référence No. de pedido	Stück Quantity Quantites Cantidades			Hinweise Hints Indications Indicaciones
		2L...	3L...	4L...	
34	034 670 00	2	2	—	} f. Taf./Tabl. 31, Pos. 42, 43
35	502 580 00	1	1	—	
36	036 176 00	1	1	—	
37	036 165 00	1	1	—	} M 8 x 20 DIN 912-8.8 M 8 x 16 DIN 933-8.8
38	500 519 00	2	2	—	
39	500 267 00	—	—	2	

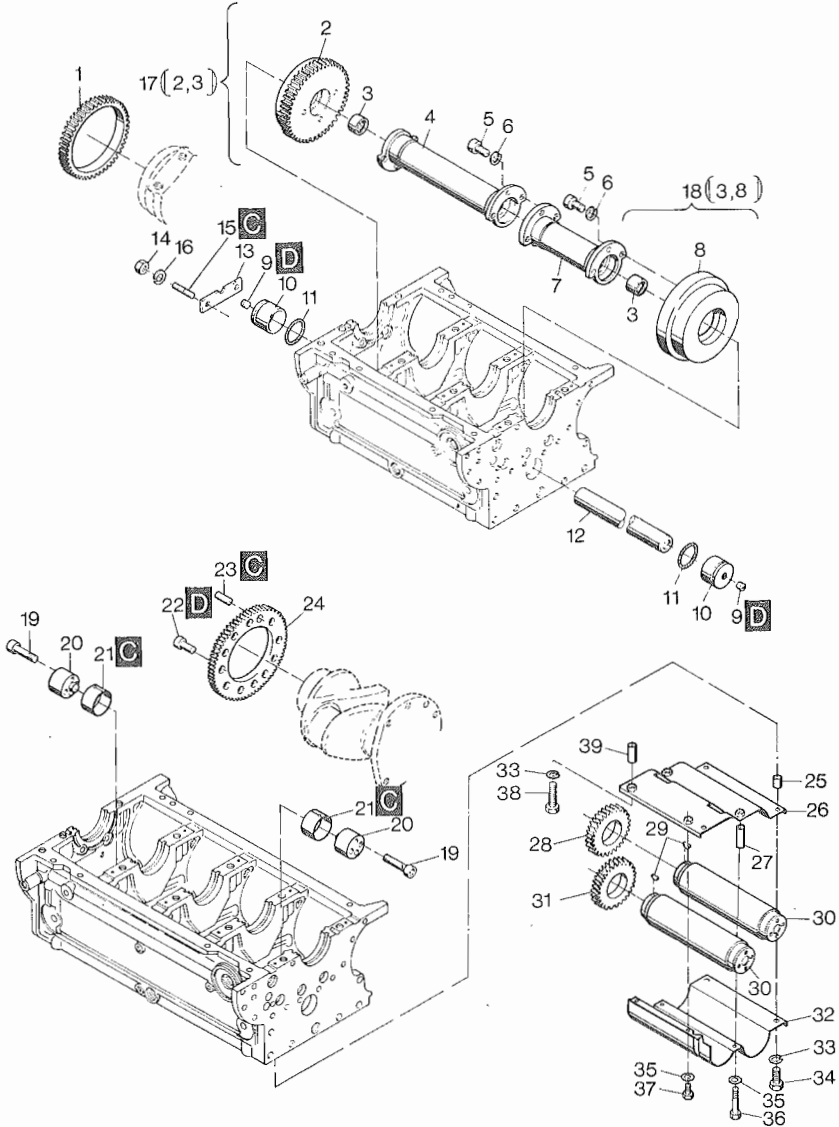

Fig. No.	Bestell-Nr. Ordering No. No. référence No. de pedido	Stück / Quantity Quantites Cantidades			Hinweise Hints Indications Indicaciones	
		2L...Z/C	3L...Z/C	4L...C		
1	035 533 00	1	1	—		
2	—	—	—	—		
3	501 285 00	2	2	—		
4	035 530 00	1	1	—		
5	500 520 00	6	9	—	M 8 x 20	DIN 6912-8.8
6	501 282 00	6	9	—	8	DIN 127
7	035 683 00	—	1	—		
8	—	—	—	—		
9	500 436 00	2	2	—	M 10 x 1	DIN 906
10	034 634 00	2	2	—		
11	501 322 00	2	2	—		
12	035 900 00	—	1	—		
12	034 635 00	1	—	—		
13	034 629 00	1	1	—		
14	500 229 00	2	2	—	M 8	DIN 934-8
15	502 408 00	2	2	—	M 8 x 12	DIN 938-8.8
16	500 028 00	2	2	—	8	DIN 128
17	009 020 00	1	1	—		
18	009 019 00	1	1	—		
19	501 279 00	—	—	16	M 8 x 40	DIN 912-10.9
20	036 270 00	—	—	4		
21	036 272 01	—	—	4		
22	502 044 00	—	—	8	M 10 x 20	DIN 6912-12.9
23	502 043 00	—	—	1	10m 6x20	DIN 7-St 50K
24	035 538 04	—	—	1		
25	035 996 00	—	—	2		
26	009 178 00	—	—	1		
27	035 998 00	—	—	2		
28	035 534 03	—	—	1		
29	500 177 00	—	—	2	4 x 5	DIN 6888
30	009 356 00	—	—	2		
31	035 536 03	—	—	1		
32	035 992 00	—	—	1		
33	500 028 00	—	—	4	8	DIN 128
34	500 519 00	—	—	2	M 8 x 20	DIN 912-8.8
35	500 812 00	—	—	4	A 6	DIN 137

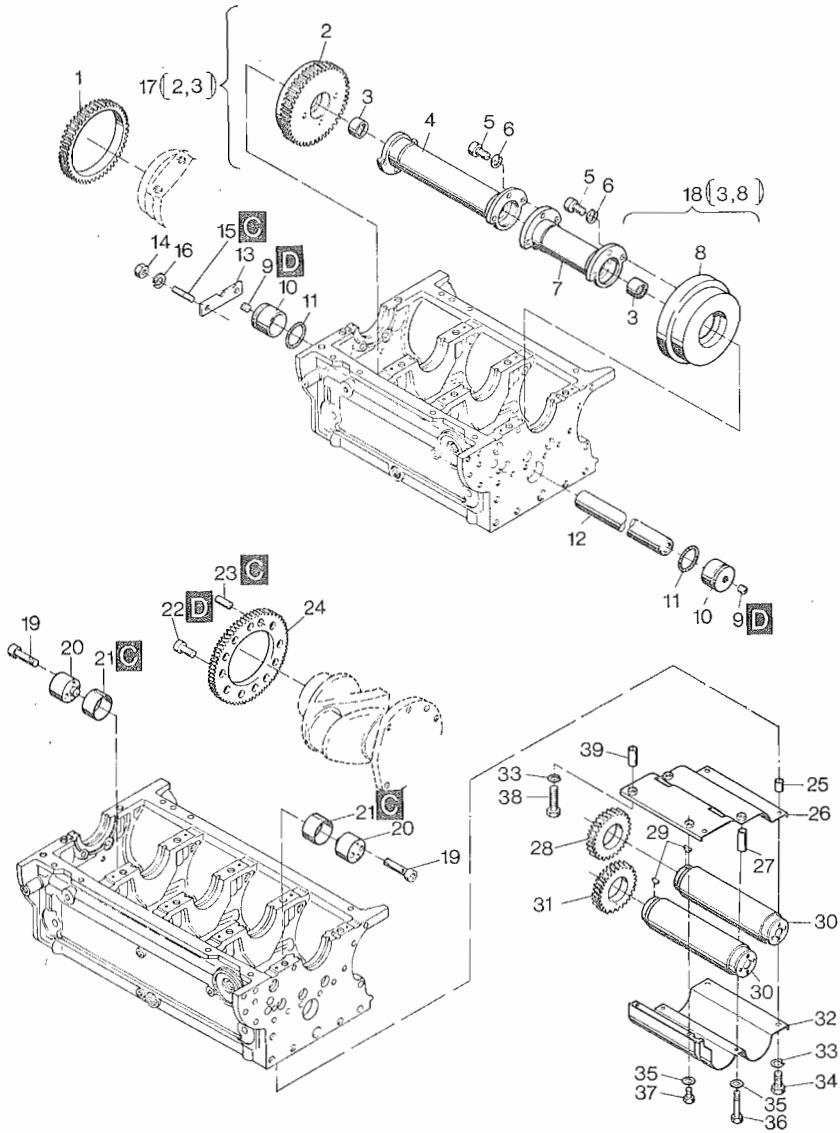

Fig. No.	Bestell-Nr.	Stück			Hinweise	
	Ordering No.	Quantity	Quantity	Quantity	Hints	
	No. référence	Quantites	Quantites	Quantites	Indications	
	No. de pedido	Cantidades	Cantidades	Cantidades	Indicaciones	
		2 L...Z/C	3 L...Z/C	4 L...C		
36	500 737 00	--	--	2	M 6 x 45	DIN 931-8.8
37	500 506 00	--	--	2	M 6 x 12	DIN 931-8.8
38	500 521 00	--	--	2	M 8 x 25	DIN 912-8.8
39	035 997 00	--	--	2		

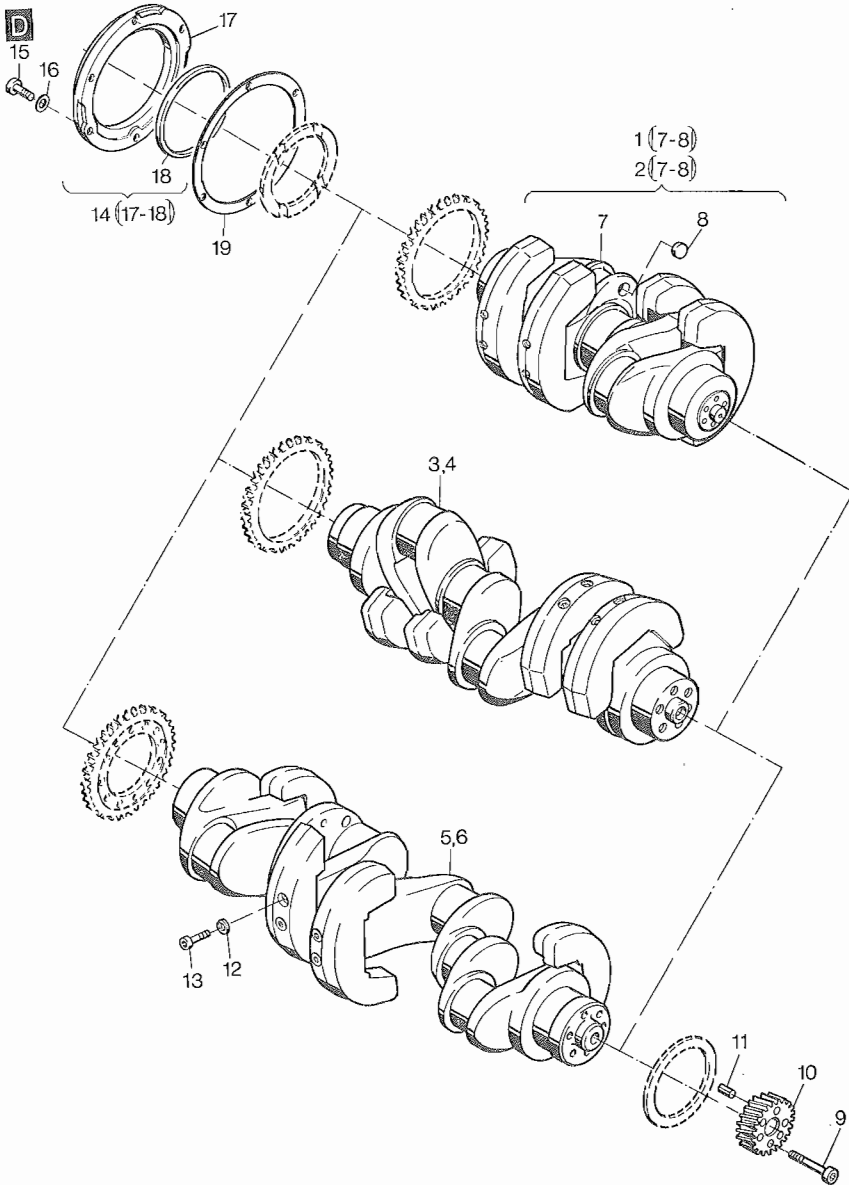

Fig. No.	Bestell-Nr. Ordering No. No. référence No. de pedido	Stück Quantity Quantités Cantidades			Hinweise Hints Indications Indicaciones	
		2 L...	3 L...	4 L...		
1	009 727 00	1	—	—	2 L 31	
2	009 508 01	1	—	—	2 L 40	
3	009 902 00	—	1	—	3 L 31	
4	009 550 00	—	1	—	3 L 40	
5	009 948 00	—	—	1	4 L 31	
6	009 563 00	—	—	1	4 L 40	
7	—	—	—	—		
8	502 072 00	2	—	—	2 L 40	
9	501 279 00	6	6	6	M 8 x 40	DIN 912-10.9
10	035 616 01	1	1	1		
11	501 280 00	1	1	1	11 x 10	DIN 7346 55SI7
12	500 029 00	8	8	8	10	DIN 128
13	501 328 00	8	8	8	M 10 x 40	DIN 912-10.9
14	009 575 00	1	1	1		
15	502 366 00	6	6	6	M 6 x 25	DIN 912-8.8
16	500 812 00	6	6	6	A 6	DIN 137
17	—	—	—	—		
18	502 246 01	1	1	1	80 x 100 x 10	
19	035 506 01	1	1	1		

M 04

Nockenwelle, Regler, Spritzversteller
Camshaft, governor, timer
Arbre à cames, regulateur, variateur d'avance
Arbol de levas, regulador, variador de avance

Tafel Nr.
Tabl. No.

06

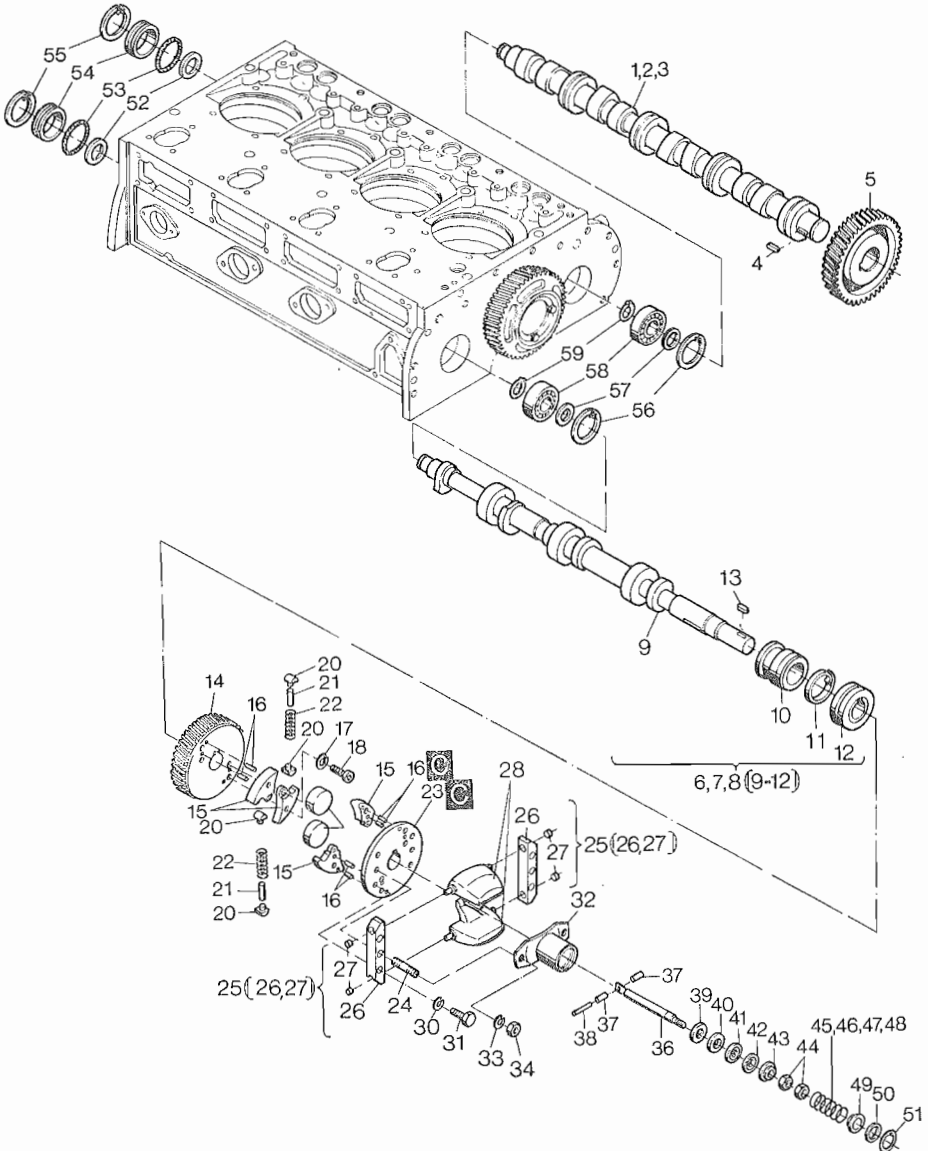

Fig. No.	Bestell-Nr. Ordering No. No. référence No. de pedido	Stück Quantity Quantités Cantidades			Hinweise Hints Indications Indicaciones
		2L...	3L...	4L...	
1	035 567 00	1	—	—	
2	035 557 00	—	1	—	
3	035 580 00	—	—	1	
4	500 113 00	1	1	1	A 8 x 7 x 22 DIN 6885
5	035 618 00	1	1	1	
6	012 120 00	1	—	—	
7	012 121 00	—	1	—	
8	012 122 00	—	—	1	
9	—	—	—	—	
10	—	—	—	—	
11	035 765 01	1	1	1	
12	—	—	—	—	
13	501 316 00	1	1	1	A 6 x 6 x 20 DIN 6885 ST6
14	035 619 00	1	1	1	
15	034 627 01	4	4	4	
16	500 579 00	8	8	8	4 m 6 x 8 DIN 7-9S 20K
17	501 401 00	8	8	8	6 DIN 7980
18	501 432 00	8	8	8	M 6 x 18 DIN 6912-8.8
19	034 601 00	2	2	2	
20	034 645 00	4	4	4	
21	035 613 00	2	2	2	
22	035 614 00	2	2	2	
23	035 547 00	1	1	1	
24	501 315 00	2	2	2	M 8 x 30 DIN 938-8.8
25	007 458 00	2	2	2	
26	—	—	—	—	
27	035 721 00	4	4	4	
28	035 729 00	2	2	2	
30	501 282 00	4	4	4	8 DIN 127
31	500 270 00	4	4	4	M 8 x 25 DIN 938-8.8
32	037 731 01	1	1	1	
33	400 278 00	2	2	2	8
34	500 229 00	2	2	2	
35	—	—	—	—	
36	037 726 00	1	1	1	
37	037 725 00	2	2	2	

M 04

Nockenwelle, Regler, Spritzversteller
Camshaft, governor, timer
Arbre à cames, regulateur, variateur d'avance
Arbol de levas, regulador, variador de avance

Tafel Nr.
Tabl. No.

06

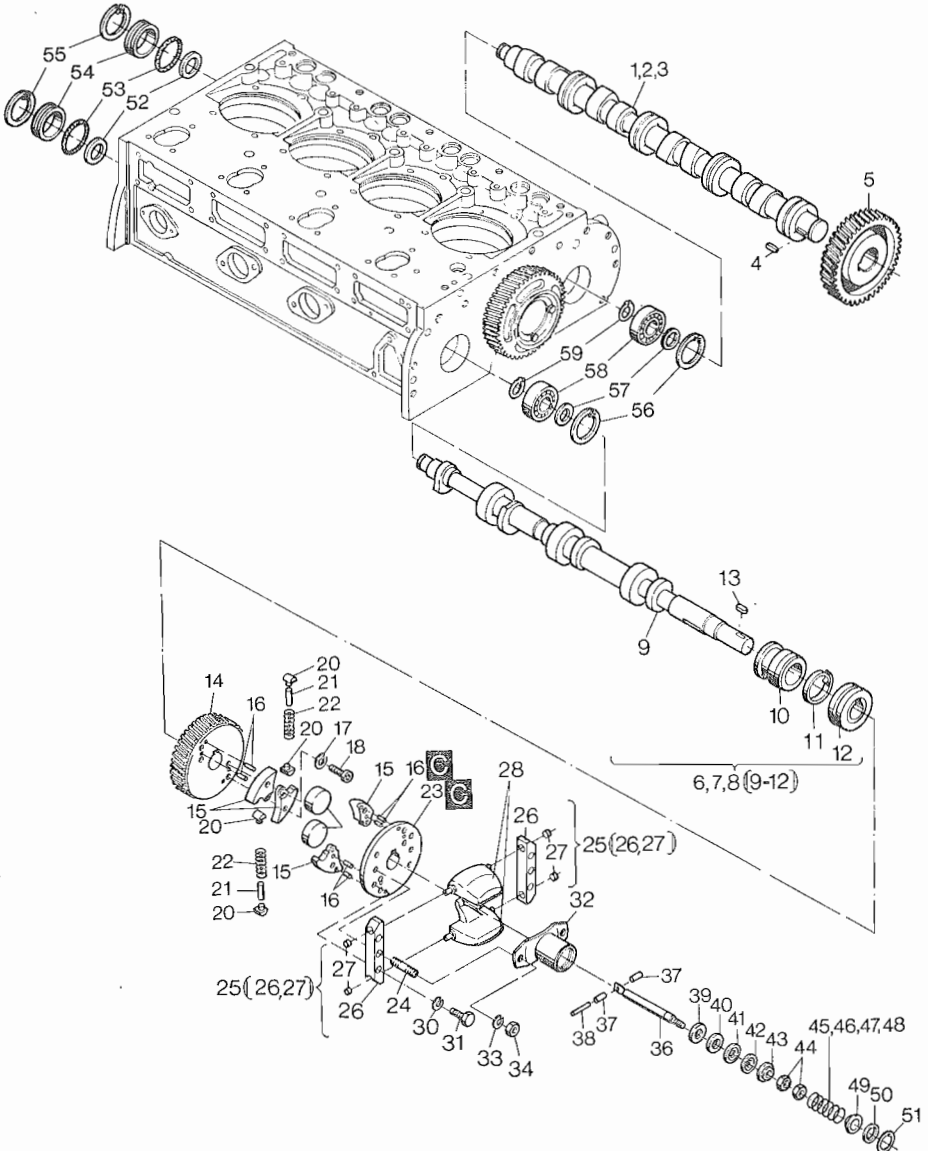

Fig. No.	Bestell-Nr. Ordering No. No. référence No. de pedido	Stück Quantity Quantités Cantidades			Hinweise Hints Indications Indicaciones
		2L...	3L...	4L...	
38	035 764 00	1	1	1	
39	037 727 00	1	1	1	
40	502 680 00	1	1	1	6 x 12 x 0,5 DIN 988
41	502 681 00	1	1	1	
42	502 682 00	1	1	1	
43	037 728 00	1	1	1	
44	500 227 00	2	2	2	M 6 DIN 934-8
45	036 014 01	1	1	1	2,5 mm ϕ 1500 min ⁻¹ Gen
46	036 013 01	1	1	1	2,6 mm ϕ 1800 min ⁻¹ Gen
47	036 012 01	1	1	1	3,0 mm ϕ \leq 2300 min ⁻¹
48	035 744 01	1	1	1	3,2 mm ϕ $>$ 2300 min ⁻¹
49	035 719 00	1	1	1	
50	037 729 00	1	1	1	
51	500 210 00	1	1	1	32 x 1,2 DIN 472
52	501 327 00	0...4	0...4	0...4	37 x 47 x 0,1 DIN 472
52	502 773 00	0...1	0...1	0...1	37 x 47 x 0,5 DIN 988
53	501 307 00	2	2	2	
54	034 697 00	2	2	2	
55	500 217 00	2	2	2	47 x 1,75 DIN 472
56	500 217 00	2	2	2	47 x 1,75 DIN 472
57	501 329 00	0...3	0...3	0...3	20 x 28 x 0,1 DIN 988
58	500 137 00	2	2	2	C3 DIN 6204
59	501 276 00	2	2	2	AS 20 x 1,75 DIN 471

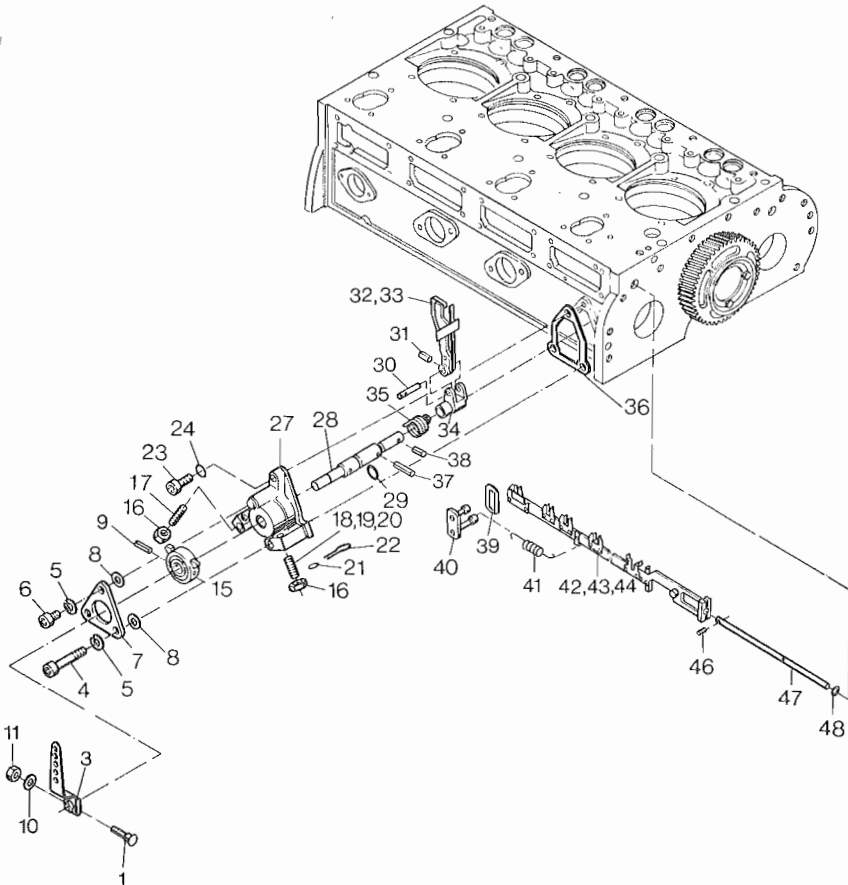

Fig. No.	Bestell-Nr.	Stück			Hinweise	
	Ordering No.	Quantity	Quantity	Quantity	Hints	
	No. référence	Quantités	Quantités	Quantités	Indications	
	No. de pedido	Cantidades			Indicaciones	
		2L...	3L...	4L...		
1	039 273 00	1	1	1	M 6x32	DIN 603-8.8 A3C
2	—	—	—	—		
3	038 883 00	1	1	1		
4	500 530 00	2	2	2	M 8 x 70	DIN 912-8.8
5	501 282 00	3	3	3	8	DIN 127
6	500 516 00	1	1	1	M 8 x 16	DIN 912-8.8
7	034 658 00	1	1	1		
8	032 130 00	0...3	0...3	0...3	0,3 mm	
8	032 131 00	0...3	0...3	0...3	0,5 mm	
9	500 350 00	1	1	1	5 x 40	DIN 1481
10	501 143 00	1	1	1	6,4	DIN 7349 Zn
11	501 444 00	1	1	1	M 6	DIN 934-8 A3C
12	—	—	—	—		
13	—	—	—	—		
14	—	—	—	—		
15	034 688 10	1	1	1		
16	500 229 00	2	2	2	M 8	DIN 934-8
17	032 459 00	1	1	1	AM 8x35	
18	032 459 00	1	1	1	AM 8x35	n > 2600 min ⁻¹
19	036 429 00	1	1	1	AM 8x45	n = 2200...2600 min ⁻¹
19	037 740 00	1	1	1	AM 8x40	n = 2200...2600 min ⁻¹
20	031 695 01	1	1	1	AM 8x50	n < 2200 min ⁻¹
21	400 214 00	1	1	1		
22	400 215 00	1	1	1		
23	500 519 00	1	1	1	M 8 x 20	DIN 912-8.8
24	501 629 00	1	1	1	A 8 x 14	DIN 7603-Cu
25	—	—	—	—		
26	—	—	—	—		
27	035 542 11	1	1	1		
28	034 689 40	1	1	1		
29	400 817 00	1	1	1		
30	034 690 10	1	1	1		
31	501 275 00	1	1	1	3 x 14	DIN 1481
32	010 862 00	1	1	1	L 40	
33	012 138 00	1	1	1	L 31	
34	034 691 10	1	1	1		

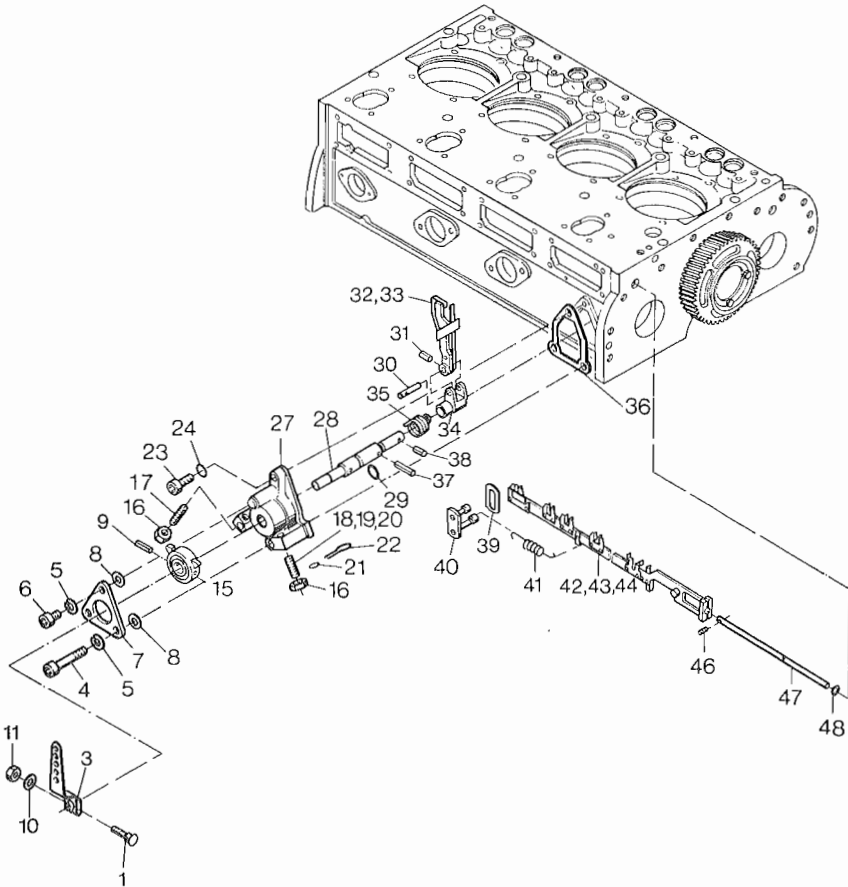

Fig. No.	Bestell-Nr. Ordering No. No. référence No. de pedido	Stück Quantity Quantites Cantidades			Hinweise Hints Indications Indicaciones	
		2L...	3L...	4L...		
35	038 61400	1	1	1		
36	034 659 00	1	1	1		
37	502 690 00	1	1	1	4 x 26	DIN 1481
38	501 319 00	1	1	1	4 x 12	DIN 1481
39	038 650 00	0...3	0...3	0...3		
40	010 667 00	1	1	1		
41	034 681 00	1	1	1		
42	010 668 02	1	—	—		
43	010 669 02	—	1	—		
44	010 670 02	—	—	1		
46	501 318 00	1	1	1	2,5 x 10	DIN 1481
47	034 606 00	1	1	1		
48	400 223 00	1	1	1	8 x 2	

M 05

Kolben, Pleuel
Piston, conrod
Piston, bielle
Embolo, biela

M 06

Zylinder
Cylinder
Cylindre
Cilindro

Tafel Nr.
Tabl. No.

08

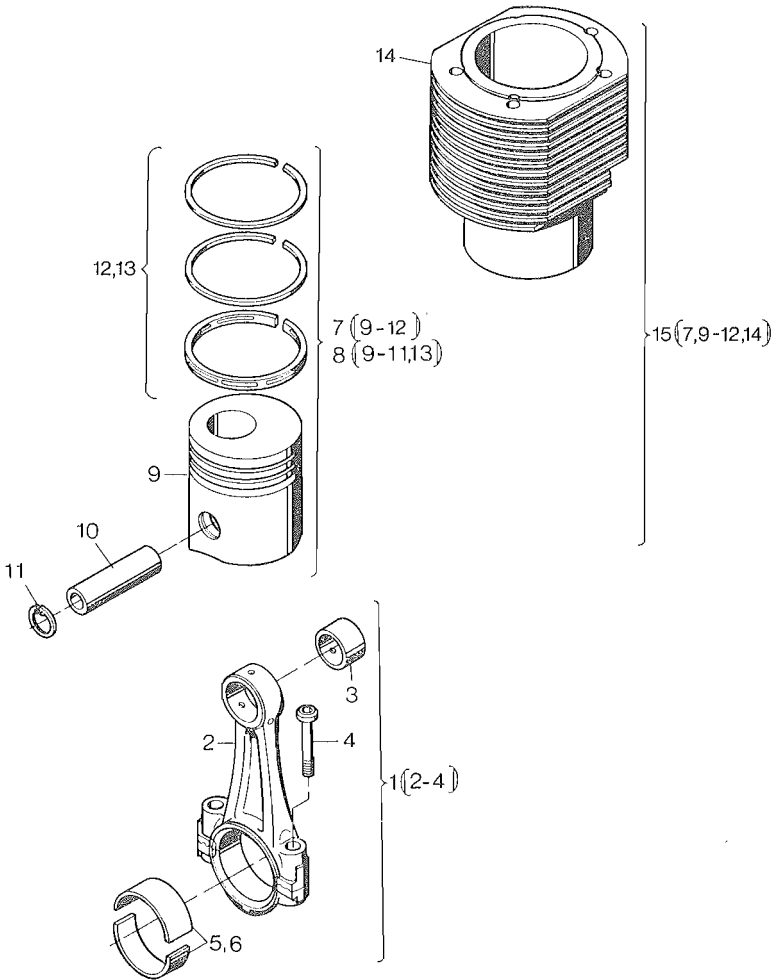

Fig. No.	Bestell-Nr. Ordering No. No. référence No. de pedido	Stück Quantity Quantites Cantidades						Hinweise Hints Indications Indicaciones
		2 L31	3 L31	4 L31	2 L40	3 L40	4 L40	
1	009 297 02	2	3	4	2	3	4	
2	—	—	—	—	—	—	—	
3	037 530 00	2	3	4	2	3	4	
4	037 752 00	4	6	8	4	6	8	
5	036 184 01	2	3	4	2	3	4	
6	037 531 00	2	3	4	2	3	4	- 0,5 mm
7	012 136 00	2	3	4	—	—	—	
7	009 541 01	—	—	—	2	3	4	
8	012 359 00	2	3	4	—	—	—	+0,5 mm
8	012 357 00	—	—	—	2	3	4	+0,5 mm
9	—	—	—	—	—	—	—	
10	502 361 00	2	3	4	2	3	4	
11	502 360 00	4	6	8	4	6	8	36 x 1,5 DIN 472
12	009 558 00	2	3	4	2	3	4	
13	012 358 00	2	3	4	2	3	4	+0,5 mm
14	036 185 02	2	3	4	2	3	4	
15	012 182 00	2	3	4	—	—	—	
15	009 734 01	—	—	—	2	3	4	

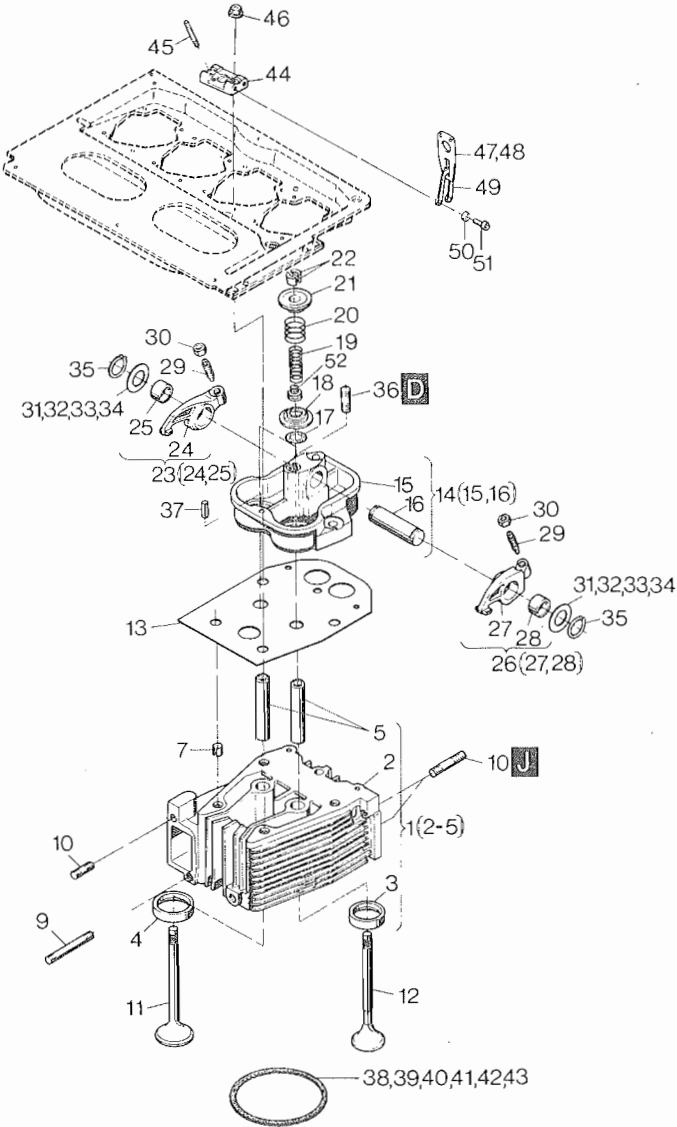

Fig. No.	Bestell-Nr. Ordering No. No. référence No. de pedido	Stück Quantity Quantites Cantidades			Hinweise Hints Indications Indicaciones	
		2L...	3L...	4L...		
1	009 330 01	2	3	4		
2	—	—	—	—		
3	—	—	—	—		
4	—	—	—	—		
5	034 487 01	4	6	8		
6	—	—	—	—		
7	502 248 00	8	12	16	13 x 14	DIN 7346
8	—	—	—	—		
9	501 325 00	2	3	4	M 8 x 65	DIN 835-8.8
10	501 281 00	6	9	12	M 8 x 30	DIN 935-10.9
11	036 255 01	2	3	4		
12	036 256 00	2	3	4		
13	036 248 00	2	3	4		
14	009 562 00	2	3	4		
15	—	—	—	—		
16	034 698 00	2	3	4		
17	502 881 00	4	6	8		
18	033 930 10	4	6	8		
19	031 835 00	4	6	8		
20	033 256 00	4	6	8		
21	030 434 02	4	6	8		
22	036 209 00	4	6	8		
23	005 325 00	2	3	4		
24	—	—	—	—		
25	031 841 00	2	3	4		
26	009 328 00	2	3	4		
27	—	—	—	—		
28	031 841 00	2	3	4		
29	030 431 00	4	6	8	n > 2300 min ⁻¹	
29	037 720 00	4	6	8	n < 2300 min ⁻¹	
30	031 490 00	4	6	8		
31	035 806 00	0...4	0...6	0...8	0,15 mm	
32	032 332 00	0...4	0...6	0...8	0,20 mm	
33	032 333 00	0...4	0...6	0...8	0,30 mm	
34	034 560 00	0...4	0...6	0...8	0,40 mm	
35	500 202 00	4	6	8	19 x 1,2	DIN 471

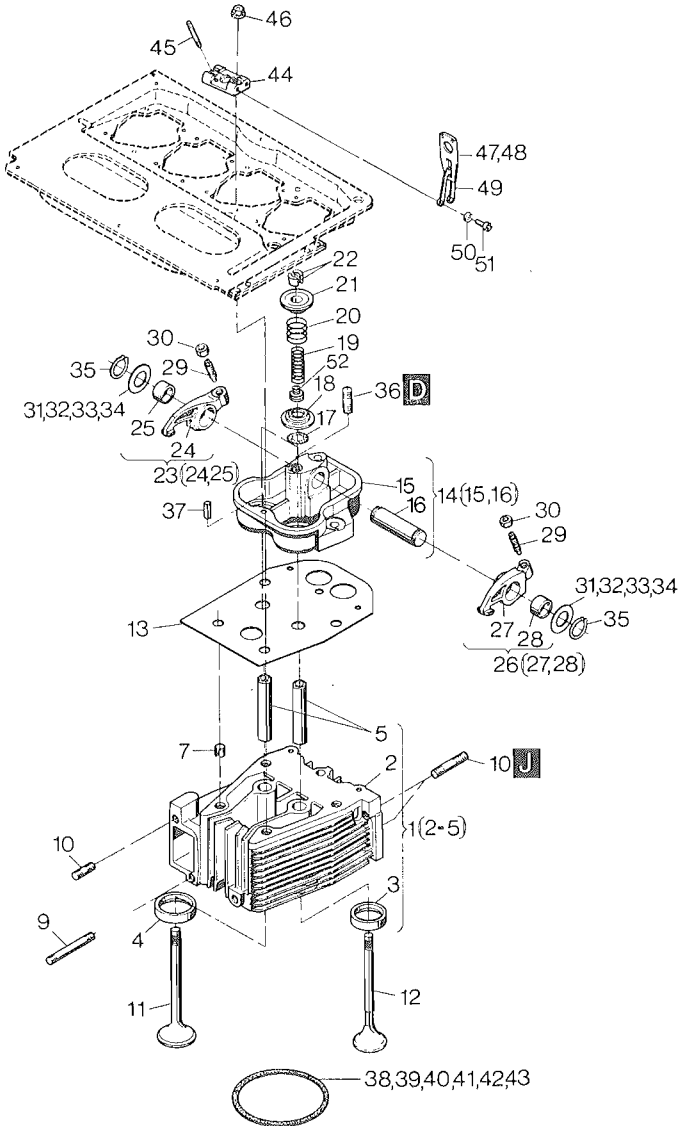

Fig. No.	Bestell-Nr. Ordering No. No. référence No. de pedido	Stück Quantity Quantities Cantidades			Hinweise Hints Indications Indicaciones	
		2L...	3L...	4L...		
36	500 405 00	2	3	4	M 10 x 25	DIN 939-5.6
37	500 352 00	2	3	4	6 x 12	DIN 1481
38	036 259 01	0...2	0...3	0...4	0,7 mm	
39	036 260 01	0...2	0...3	0...4	0,8 mm	
40	036 261 01	0...2	0...3	0...4	0,9 mm	
41	036 262 01	0...2	0...3	0...4	1,0 mm	
42	036 263 01	0...2	0...3	0...4	1,1 mm	
43	036 264 01	0...2	0...3	0...4	1,2 mm	
44	036 249 00	2	3	4		
45	502 390 00	4	6	8	M 8 x 55	DIN 933-8.8
46	036 481 00 P5	10	15	20		
47	035 691 00	1	1	1	S/Z	
48	035 920 00	1	1	1	C/K	
49	036 250 00	1	1	1		
50	501 282 00	2	2	2	8	DIN 127
51	501 297 00	2	2	2	M 8 x 18	DIN 912-10.9
52	502 848 00	4	6	8	n ≤ 2300 min ⁻¹	

M 09

Stoßstange
Pushrod
Tige de culbuteur
Varilla de balancin

M 10

Ölpumpe
Oil pump
Pompe a huile
Bomba de aceite

Tafel Nr.
Tabl. No.

10

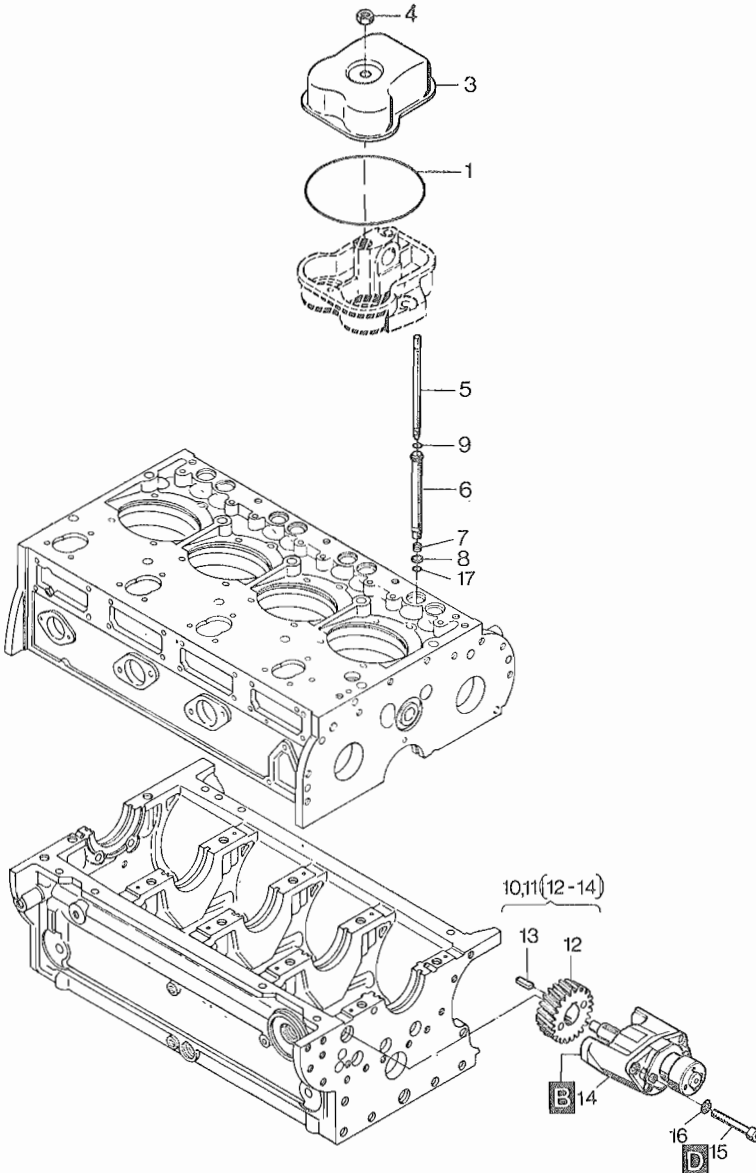

Fig. No.	Bestell-Nr. Ordering No. No. référence No. de pedido	Stück Quantity Quantites Cantidades			Hinweise Hints Indications Indicaciones
		2L...	3L...	4L...	
1	502 249 00 W4/6/8	2	3	4	123x2,5
2	---	---	---	---	
3	036 426 01	2	3	4	
4	501 323 00 W2/3/4	2	3	4	M 10
5	007 436 00	4	6	8	
6	035 667 01	4	6	8	
7	031 851 00	4	6	8	
8	031 852 00	4	6	8	
9	502 580 00	4	6	8	17x3
10	009 242 04	1	1	—	
11	009 239 04	—	—	1	
12	035 620 20	1	1	1	
13	503 168 00	1	1	1	4 x 4 x 20 DIN 6885
14	---	---	---	---	
15	502 068 00	3	3	3	M 8 x 105 DIN 912-8.8
16	500 028 00	3	3	3	8 DIN 128
17	400 228 00	4	6	8	15x3,2

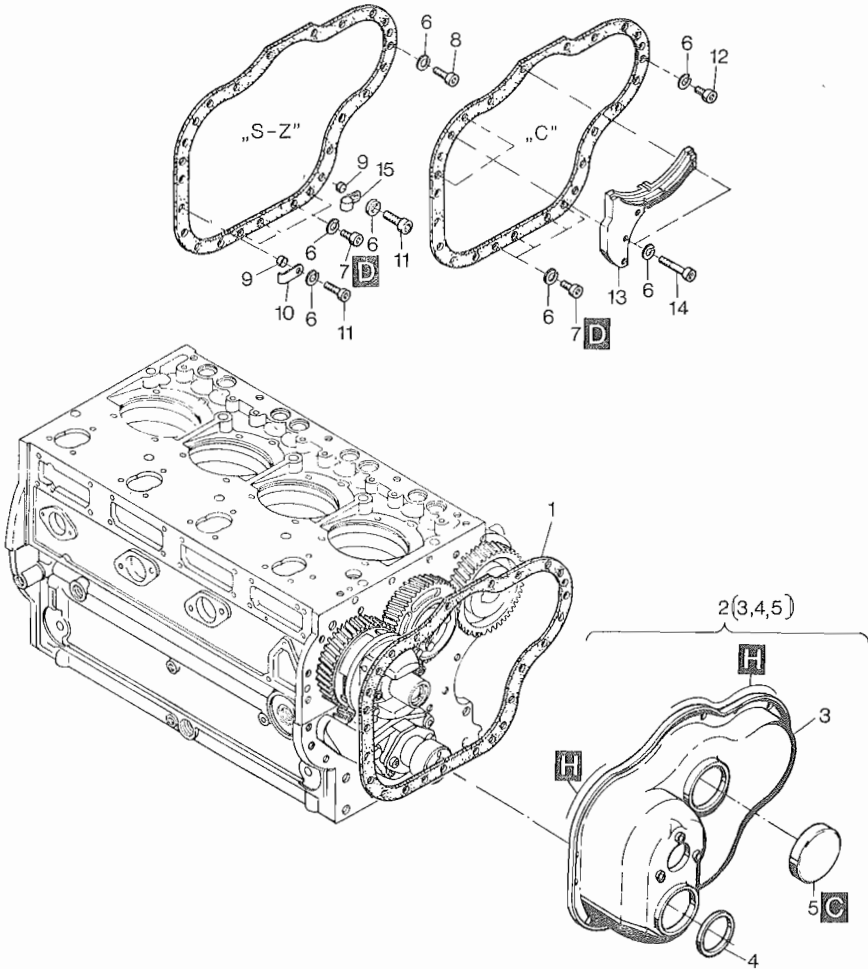

Fig. No.	Bestell-Nr.	Stück	Hinweise	
	Ordering No.	Quantity	Hints	
	No. référence	Quantites	Indications	
	No. de pedido	Cantidades	Indicaciones	
		2...4L...S/Z	2...4L...C/K	
1	035 569 01	1	1	
2	009 932 00	1	1	
3	—	—	—	
4	501 291 00	1	1	
5	501 265 00	1	1	70 DIN 442
6	500 028 00	22	22	8 DIN 128
7	502 058 00	4	4	M 8 x 12 DIN 912-8.8
8	500 516 00	16	—	M 8 x 16 DIN 912-8.8
9	031 167 00	2	—	
10	031 592 00	1	—	
11	500 521 00	2	—	M 8 x 25 DIN 912-8.8
12	500 516 00	—	13	M 8 x 16 DIN 912-8.8
13	009 028 00	—	1	
14	500 528 00	—	5	M 8 x 55 DIN 912-8.8
15	031 655 00	1	—	

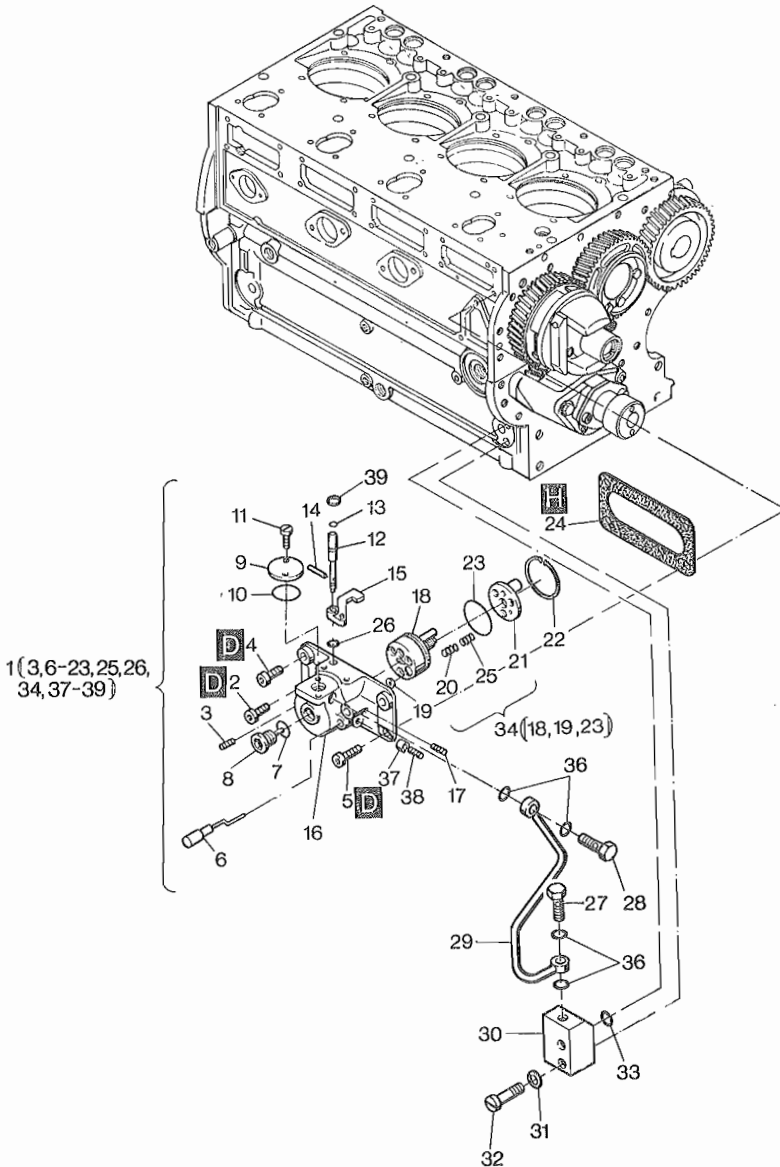

Fig. No.	Bestell-Nr.	Stück	Hinweise	
	Ordering No.	Quantity	Hints	Indications
	No. référence	Quantites	Indications	
	No. de pedido	Cantidades	Indicaciones	
		2...4L...S/Z	2...4L...C/K	
1	012 019 03	1	1	
2	501 349 00	1	1	M 8 x 16 DIN 6912-8.8
3	502 624 00	1	1	M 6 x 10 DIN 916
4	501 289 00	1	1	M 8 x 16 DIN 912-8.8
5	400 808 00	2	2	M 8 x 20 DIN 912
6	010 762 00	1	1	
7	500 012 00	1	1	14 x 18 DIN 7603-Cu
8	010 978 00	1	1	M 14 x 1,5
9	038 591 00	1	1	
10	501 304 00	1	1	16,3x2,4
11	503 180 00	2	2	M 4x8 DIN 912-8.8
12	038 288 00	1	1	
13	400 217 00	1	1	4,47 x 8,03 x 1,78
14	501 318 00	1	1	2,5 x 10 DIN 1481
15	036 702 10	1	1	
16	—	—	—	
17	502 863 00	1	1	6x16 DIN 915-45 H
18	—	—	—	
19	038 515 01	1	1	
20	038 811 00	3	3	
21	038 542 00	1	1	
22	500 215 00	1	1	42 x 1,75 DIN 472
23	502 631 00	1	1	37,8 x 1,5
24	036 140 00	1	1	
25	038 813 00	3	3	
26	501 172 00	1	1	4 DIN 6799
27	039 170 00	1	1	
28	500 061 00	1	1	A 2/3 DIN 7623-Zn
29	038 801 00	1	1	
30	038 806 00	1	1	
31	500 035 00	2	2	B 8 DIN 137
32	500 523 00	2	2	M 8 x 35 DIN 912-8.8
33	501 304 00	1	1	16,3 x 2,4
34	012 018 11	1	1	
35	—	—	—	
36	500 009 00	4	4	A 8 x 11,5 DIN 7603-Cu
37	038 895 00	1	1	
38	502 623 00	1	1	M 4x10 DIN 915-45H TU
39	503 244 00	1	1	

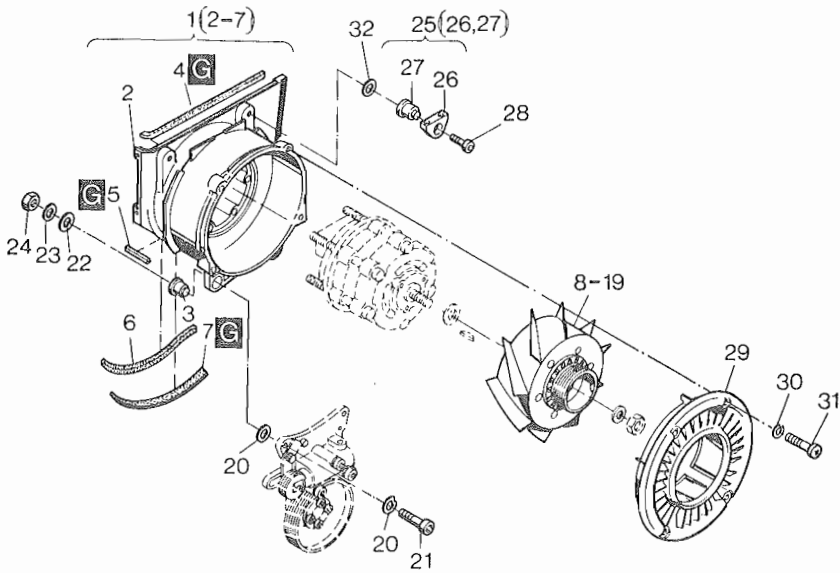

Fig. No.	Bestell-Nr. Ordering No. No. référence No. de pedido	Stück Quantity Quantites Cantidades			Hinweise Hints Indications Indicaciones
		2...4 L31 S/Z 2...3 L40 S/Z	4 L40 S/Z	2...4 L...C/K	
1	007 402 01	1	—	—	
1	012 037 00	—	1	1	
2	—	—	—	—	
3	035 625 00	2	2	2	
4	035 526 00	1	1	1	335 mm
5	035 985 00	1	1	1	33 mm
6	035 524 01	1	1	1	240 mm
7	036 127 00	1	1	1	193 mm
8	009 202 01	1	—	—	2 L 31 S/Z
9	009 590 00	1	—	—	2 L 40 S/Z
10	012 114 00	—	—	1	2 L 31 C
11	012 052 01	—	—	1	2 L 40 C
12	009 209 01	1	—	—	3 L 31 S/Z
13	009 897 01	1	—	1	3 L 40 S/Z, 4 L 40 C/K
14	012 051 01	—	—	1	3 L 31 C
15	009 991 00	—	—	1	3 L 40 C
16	009 351 00	1	—	—	4 L 31 S/Z
17	009 900 10	—	1	—	4 L 40 S/Z
18	009 702 01	—	—	1	4 L 31 C/K
19	—	—	—	—	
20	500 617 00	4	4	4	A 10 DIN 137
21	500 551 00	2	2	2	M 10 x 55 DIN 912-8.8
22	500 706 00	2	2	2	10,5 DIN 7349
23	501 278 00	2	2	2	A 10 DIN 127
24	500 235 00	2	2	2	M 10 DIN 934-8
25	009 198 00	2	2	2	
26	—	—	—	—	
27	035 625 00	2	2	2	
28	500 526 00	2	2	2	M 8 x 45 DIN 912-8.8
29	037 628 00	—	—	1	
30	500 812 00	—	—	4	A 6 DIN 137
31	502 532 00	—	—	4	M 6 x 50 DIN 7985-4.8 A3R
32	035 956 00	0...4	0...4	0...4	

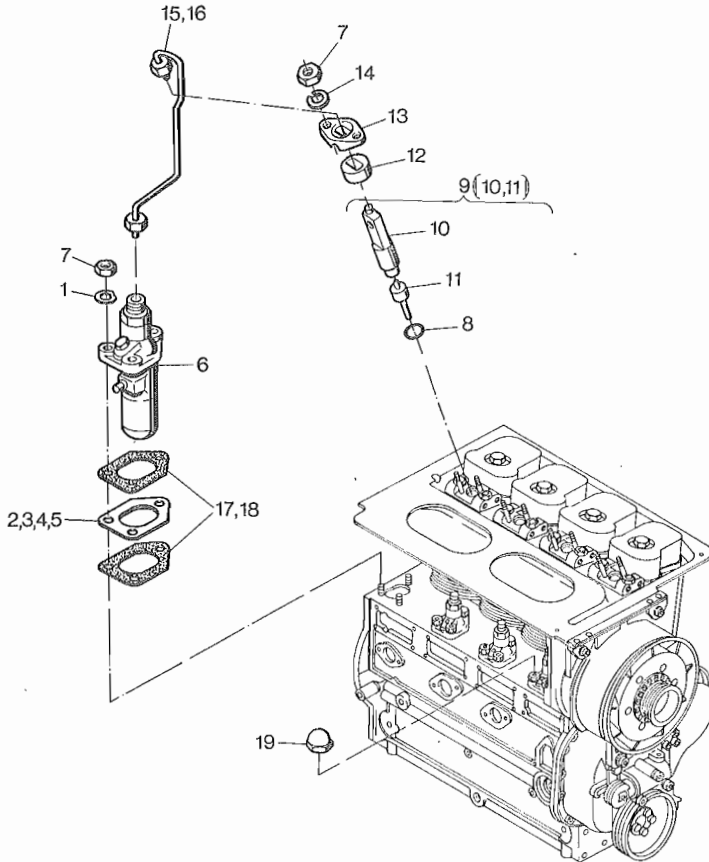

Fig. No.	Bestell-Nr. Ordering No. No. référence No. de pedido	Stück Quantity Quantites Cantidades			Hinweise Hints Indications Indicaciones	
		2L...	3L...	4L...		
1	500 035 00	6	9	12	B 8	DIN 137
2	031 687 01	0...2	0...3	0...4	0,30 mm	
3	038 971 00	0...2	0...3	0...4	0,60 mm	
4	038 972 00	0...2	0...3	0...4	0,90 mm	
5	038 973 00	0...2	0...3	0...4	1,20 mm	
6	502 630 01	2	3	4		
7	500 229 00 P4	9	14	19	M 8	DIN 934-8
8	400 850 00	2	3	4		
9	401 209 01	2	3	4		
10	—	—	—	—		
11	501 413 01 P1	2	3	4		
12	034 665 00	2	3	4		
13	034 605 00	2	3	4		
14	501 282 00 P4	4	6	8	8	DIN 127
15	012 038 00	2	3	4		
16	—	—	—	—		
17	038 968 00	0...4	0...6	0...8	0,20 mm	
18	038 969 00	0...4	0...6	0...8	0,30 mm	
19	502 676 00	1	1	1	M 8	DIN 1587

M 16

Riemenscheibe
Pulley
Poulie
Polea

M 17

Schwungrad
Flywheel
Volant
Volante

M 20

Hydr. Abstellschr.
Hydr. belt tensioner
Tendeur hydr.
Tensor hidr.

Tafel Nr.
Tabl. No.
15

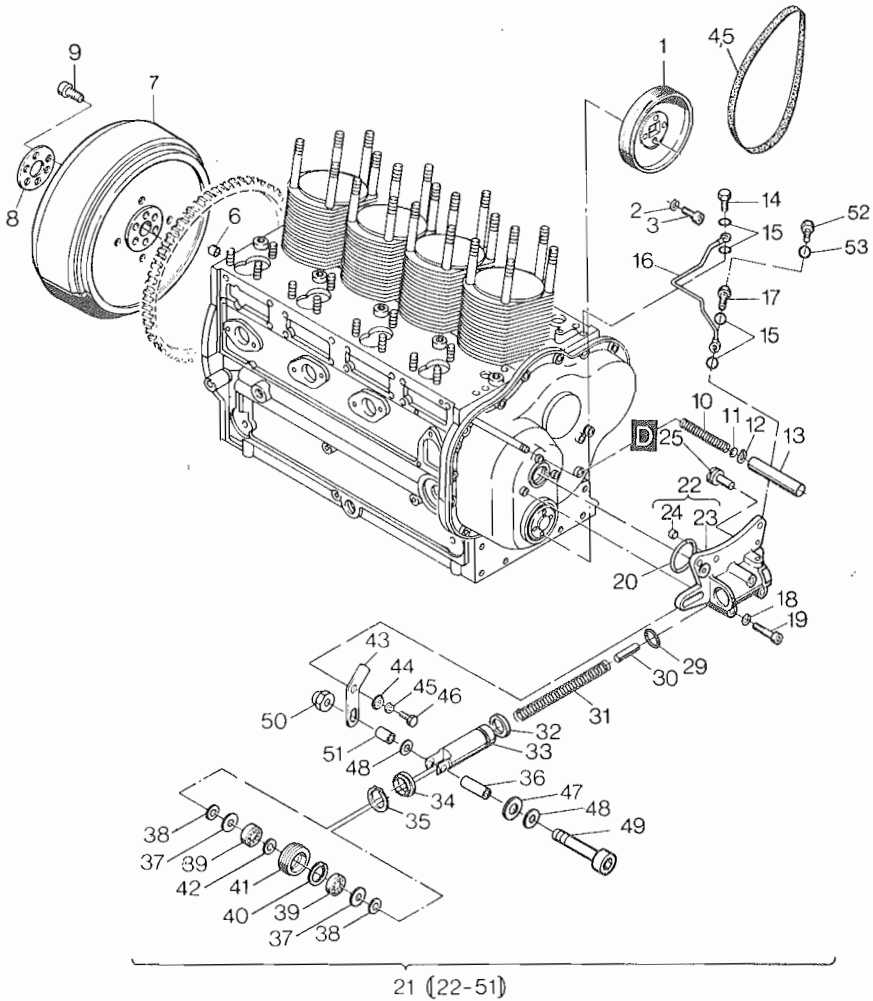

Fig. No.	Bestell-Nr. Ordering No. No. référence No. de pedido	Stück Quantity Quantites Cantidades		Hinweise Hints Indications Indicaciones	
		2...3 L31... 2 L40 C	2 L40 S/Z 3 L40... 4 L...		
1	035 898 01	1	1		
2	501 282 00	4	4	8	DIN 127
3	500 519 00	4	4	M 8 x 20	DIN 931-8.8
4	501 415 00 P1	—	1	9 J 910	
5	502 031 00 P1	1	—	9 J 920	
6	036 306 00	1	1		
7	037 337 01	1	1	SAE J 620	
8	036 458 00	1	1		
9	502 251 00	6	6	M 14x1,5x45	DIN 912-10.9
10	034 680 00	1	1		
11	031 332 00	1	1		
12	500 194 00	1	1	8 x 0,8	DIN 471
13	035 682 00	1	1		
14	500 061 00	1	1	A 2/3	DIN 7623
15	500 009 00	4	4	A 8 x 11,5	DIN 7603-Cu
16	009 100 00	1	1		
17	037 248 00	1	1		
18	500 035 00	3	3	B 8	DIN 137
19	500 818 00	3	3	M 8 x 65	DIN 912-8.8
20	501 324 01	1	1		
21	009 414 04	1	1		
22	009 276 30	1	1		
23	—	—	—		
24	400 847 00	1	1		
25	037 506 00	1	1		
26	—	—	—		
27	—	—	—		
28	—	—	—		
29	502 197 00	1	1		
30	036 393 00	1	1		
31	035 891 00	1	1		
32	502 211 00	1	1		
33	035 896 21	1	1		
34	036 430 01	1	1		
35	502 904 00	1	1	45 x 1,75	DIN 472
36	037 646 00	1	1		

M 16

Riemenscheibe
Pulley
Poulie
Polea

M 17

Schwungrad
Flywheel
Volant
Volante

M 20

Hydr. Abstellvorr.
Hydr. belt tensioner
Tendeur hydr.
Tensor hidr.

Tafel Nr.
Tabl. No.
15

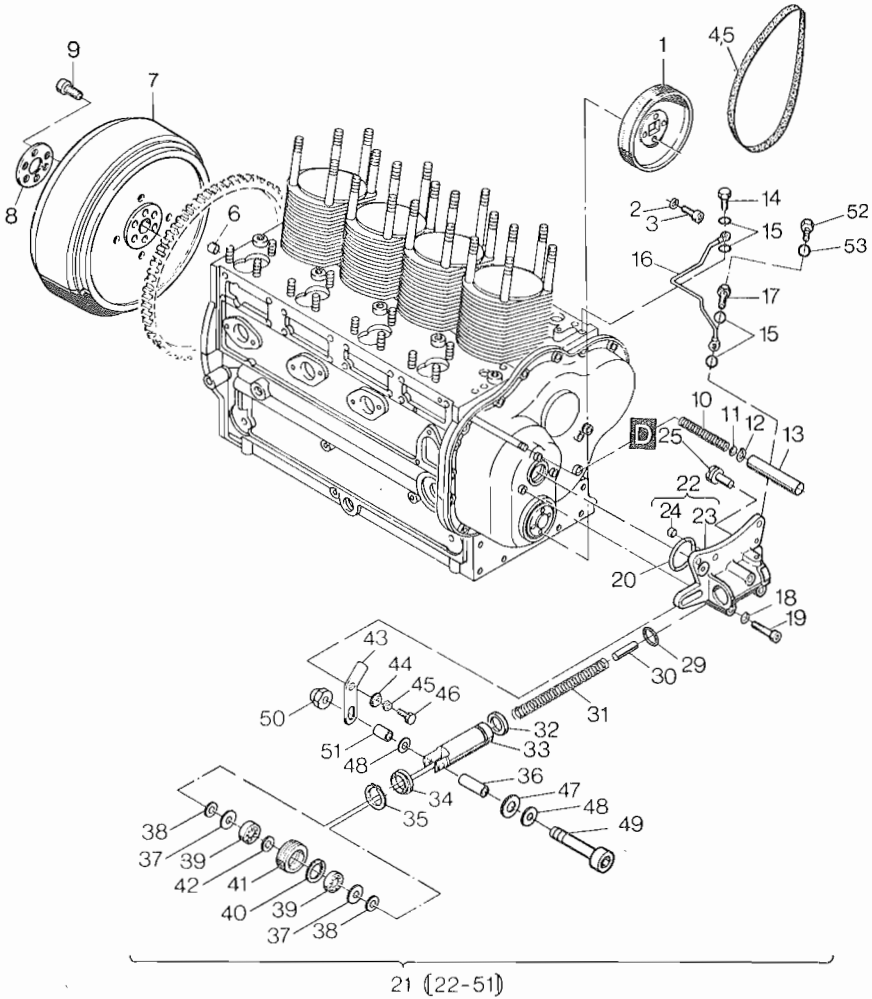

Fig. No.	Bestell-Nr. Ordering No. No. référence No. de pedido	Stück Quantity Quantites Cantidades		Hinweise Hints Indications Indicaciones	
		2... 3 L31... 2 L 40 C		2 L 40 S/Z 3 L 40 4 L...	
37	502 500 00	2		2	
38	037 648 00	2		2	
39	502 499 00	2		2	
40	500 207 00	1		1	
41	035 894 20	1		1	28 x 1,2 DIN 472
42	501 321 00	1		1	12 x 18 x 1,2
43	035 895 10	1		1	
44	035 893 00	1		1	
45	500 027 00	1		1	6 DIN 128
46	500 258 00	1		1	M 6 x 20 DIN 933-8.8
47	037 649 00	1		1	
48	500 167 00	2		2	A 8,4 DIN 125 St
49	500 818 00	1		1	M 8 x 65 DIN 912-8.8
50	400 284 00	1		1	M 8 SSN 440-8 Cu
51	037 647 00	1		1	
52	500 253 00	1		1	M 6 x 8 DIN 933-8.8
53	500 008 00	1		1	A 6,5 x 9,5 DIN 7603-Cu

M 22

Luftfilter
 Air filter
 Filtre à air
 Filtro de aire

M 27

Luftansaugrohr
 Air intake manifold
 Collecteur d'admission
 Tubo de aspiración

Tafel Nr.
 Tabl. No.

16

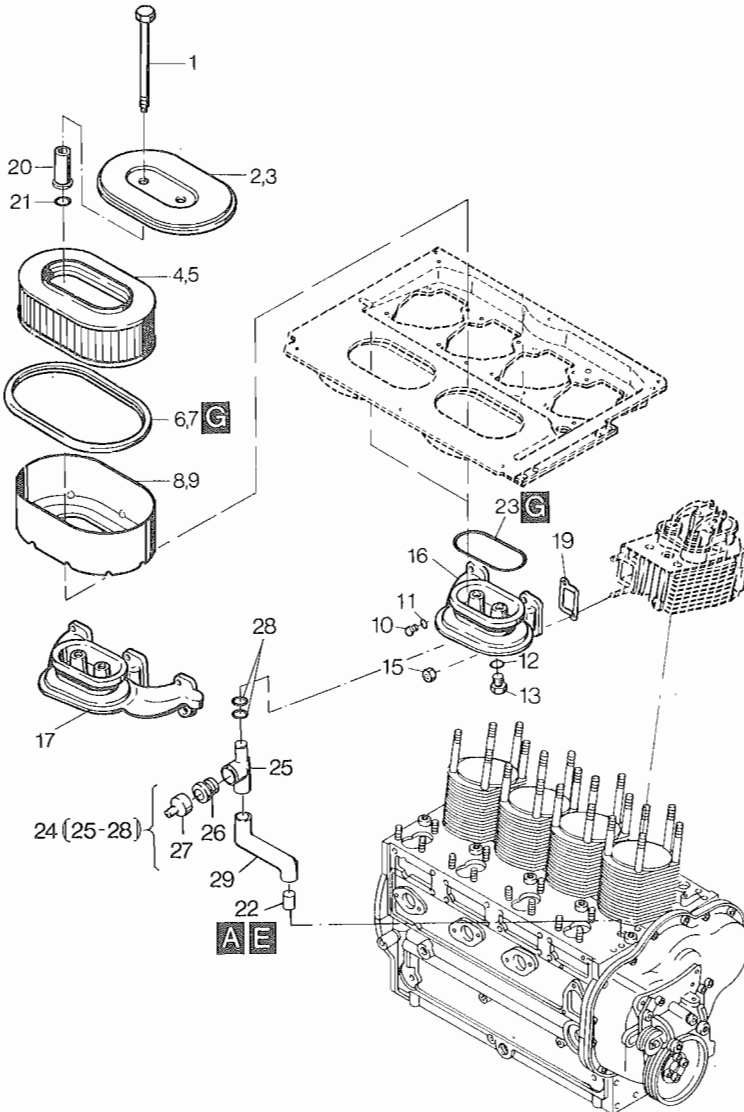

Fig. No.	Bestell-Nr. Ordering No. No. référence No. de pedido	Stück Quantity Quantités Cantidades			Hinweise Hints Indications Indicaciones
		2L...	3L...	4L...	
1	037 523 02	2	2	4	
2	009 530 01	1	—	2	
3	009 995 00	—	1	—	
4	009 529 00 W2/4	1	1	2	
5	—	—	—	—	
6	036 476 00 W1/2	1	—	2	
7	037 698 00 W1	—	1	—	
8	036 465 00	1	—	2	
9	009 994 00	—	1	—	
10	500 623 00	1	1	2	M 10 x 1 DIN 908
11	500 624 00	1	1	2	A 10 x 13,5 DIN 7603-Cu
12	500 016 00	1	1	2	A 22 x 27 DIN 7603-Cu
13	501 404 00	1	1	2	AM 22 x 1,5 DIN 7604
14	—	—	—	—	
15	502 236 00 P4	4	6	8	M 8 A3C
16	036 243 04	1	—	2	
17	036 321 03	—	1	—	
18	—	—	—	—	
19	036 244 00	2	3	4	
20	012 184 00	2	2	4	
21	400 221 00	2	2	4	7x2
22	036 490 00	1	1	1	
23	036 486 00	1	1	2	
24	009 478 00	1	1	1	
25	—	—	—	—	
26	035 687 00	1	1	1	
27	035 686 00	1	1	1	
28	503 267 00	2	2	2	9,7 x 1
29	036 489 00	1	1	1	

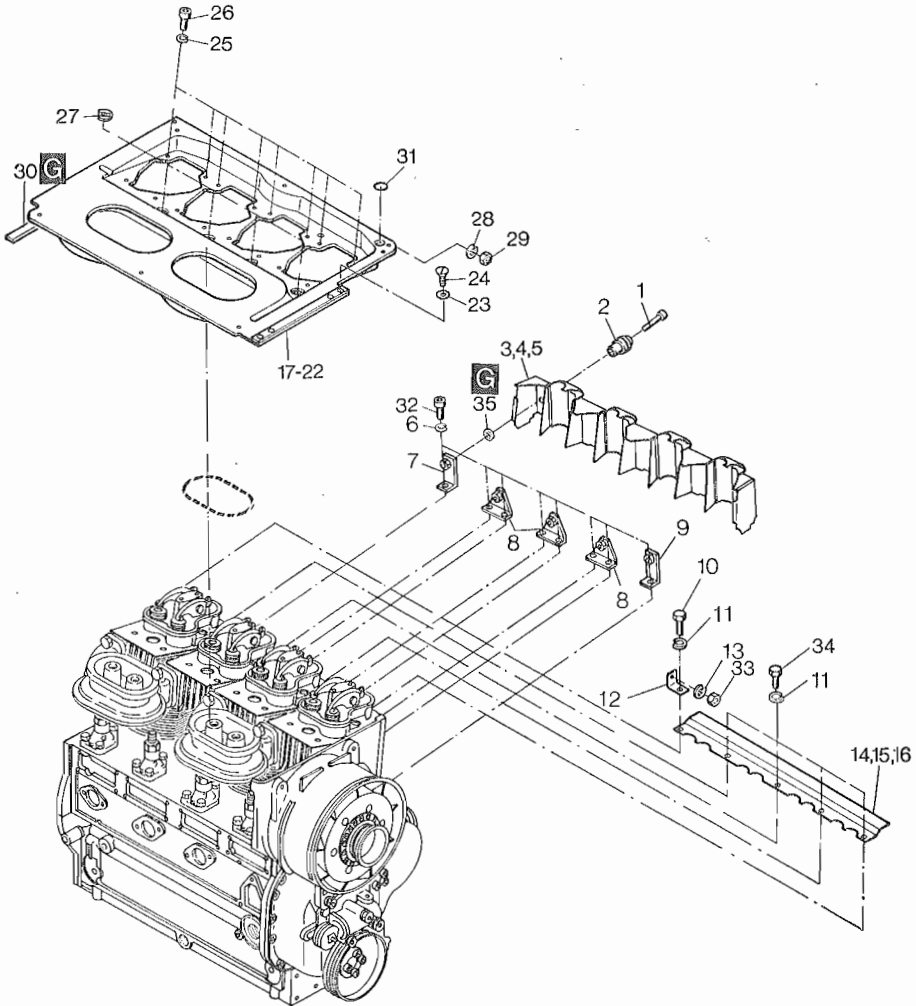

Fig. No.	Bestell-Nr. Ordering No. No. référence No. de pedido	Stück Quantity Quantites Cantidades			Hinweise Hints Indications Indicaciones	
		2L...	3L...	4L...		
1	500 511 00	3	4	5	M 6 x 30	DIN 6912-8.8
2	009 327 00	3	4	5		
3	009 380 00	1	—	—		
4	009 381 00	—	1	—		
5	009 382 00	—	—	1		
6	500 028 00	4	6	8	8	DIN 128
7	009 234 00	1	1	1		
8	009 233 00	1	2	3		
9	009 235 00	1	1	1		
10	500 267 00	1	1	1	M 8x16	DIN 933-8.8
11	500 028 00	3	6	8	8	DIN 128
12	035 856 01	1	1	1	„C/K“	
13	500 812 00	4	6	8	A 6	DIN 137
14	035 907 00	1	—	—	„C“	
15	035 915 01	—	1	—	„C“	
16	—	—	—	—		
17	009 342 01	1	—	—	„S/Z“	
18	009 343 02	1	—	—	„C“	
19	009 395 01	—	1	—	„S/Z“	
20	009 397 02	—	1	—	„C“	
21	009 396 00	—	—	1	„S/Z“	
22	009 398 02	—	—	1	„C/K“	
23	502 051 00 P4	4	4	4	V 8,4	DIN 6797
24	502 052 00 P4	4	4	4	M 8 x 16	DIN 965-8.8
25	500 812 00 P4	4	6	8	A 6	DIN 137
26	500 507 00 P4	4	6	8	M 6 x 16	DIN 912-8.8
27	035 927 00 P2	2	3	4		
28	500 027 00 P3	3	3	3	„S/Z“ 6	DIN 128
29	500 227 00 P3	3	3	3	„S/Z“ M 6	DIN 934-8
30	036 485 00	1	1	1	„C/K“	
31	012 139 00	1	1	1	„C/K“	
32	500 516 00	8	8	8	M 8x16	DIN 912-8.8
33	500 227 00	7	7	7	„C/K“ M6	DIN 934-8
34	500 266 00	2	3	—	„C“ M8x12	DIN 933-8.8
35	035 755 00	3	4	5		

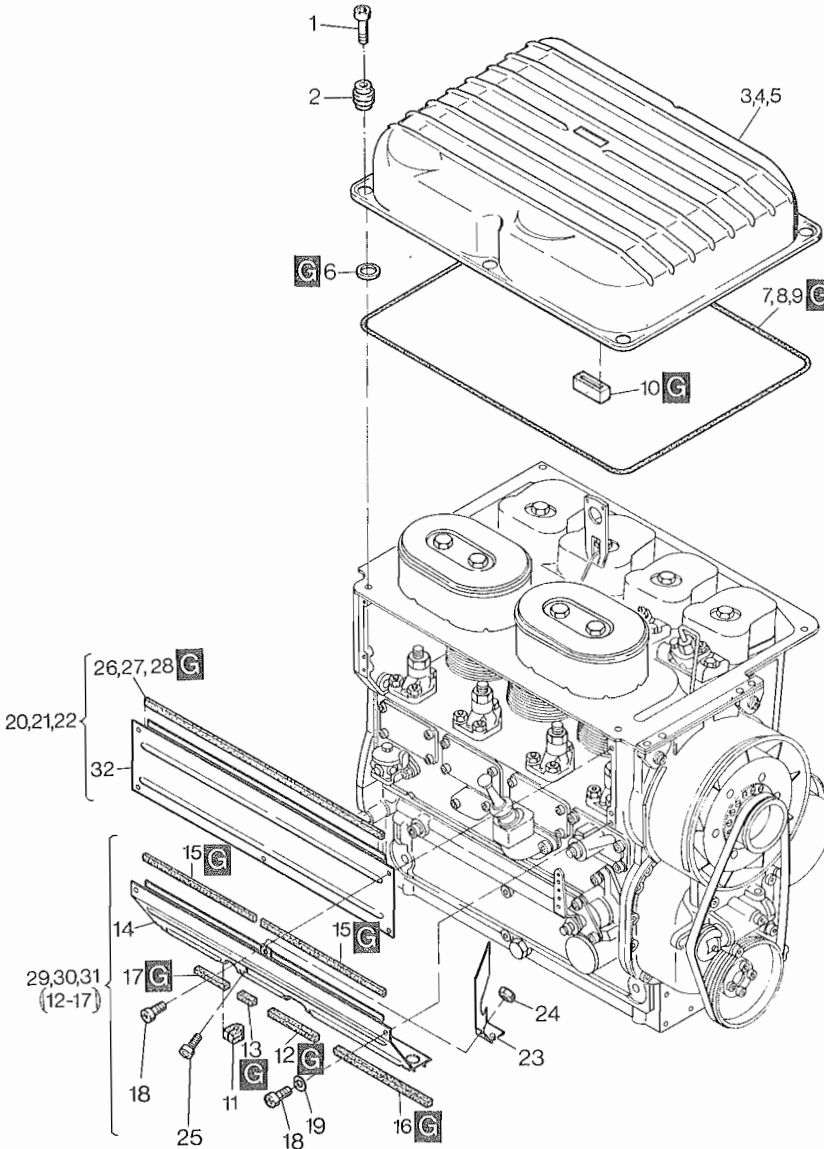

Fig. No.	Bestell-Nr. Ordering No. No. référence No. de pedido	Stück Quantity Quantites Cantidades			Hinweise Hints Indications Indicaciones	
		2 L...S/Z	3 L...S/Z	4 L...S/Z		
1	501 144 00	4	5	6	M 8 x 25	DIN 6912-8.8
2	009 214 00	4	5	6		
3	007 394 00	1	—	—		
4	007 423 01	—	1	—		
5	007 450 00	—	—	1		
6	035 755 00	4	5	6		
7	034 642 00	1	—	—		
8	035 629 00	—	1	—		
9	035 694 00	—	—	1		
10	035 690 00	1	1	1		
11	035 689 00	1	1	1		
12	035 987 00	1	—	—	47 mm	
12	035 985 00	—	1	—	32 mm	
12	035 725 01	—	—	1	97 mm	
13	035 638 00	—	1	1	67 mm	
13	035 990 00	—	—	1	30 mm	
14	—	—	—	—		
15	035 640 00	1	—	—	231 mm	
15	035 636 00	—	2	—	173 mm	
15	035 726 00	—	—	2	240 mm	
16	035 644 01	1	—	—	128 mm	
16	035 637 01	—	1	1	214 mm	
17	035 638 00	—	1	1	67 mm	
18	503 410 00	6	8	8	M 6 x 13	8.8 A3D
19	—	—	—	—		
20	007 427 00	1	—	—		
21	007 426 00	—	1	—		
22	007 451 00	—	—	1		
23	036 018 00	—	—	1		
24	500 227 00	—	—	3	M 6	DIN 934-8
25	503 410 00	—	—	3	M 6 x 13	8.8 A3D
26	035 640 00	1	—	—	231 mm	
27	035 631 00	—	1	—	366 mm	
28	035 700 00	—	—	1	501 mm	
29	007 429 11	1	—	—	} $n \leq 1500 \text{ min}^{-1}$	
30	007 428 11	—	1	—		
31	007 462 11	—	—	1		s. Taf./Tabl. 32, Pos. 8-13
32	—	—	—	—		

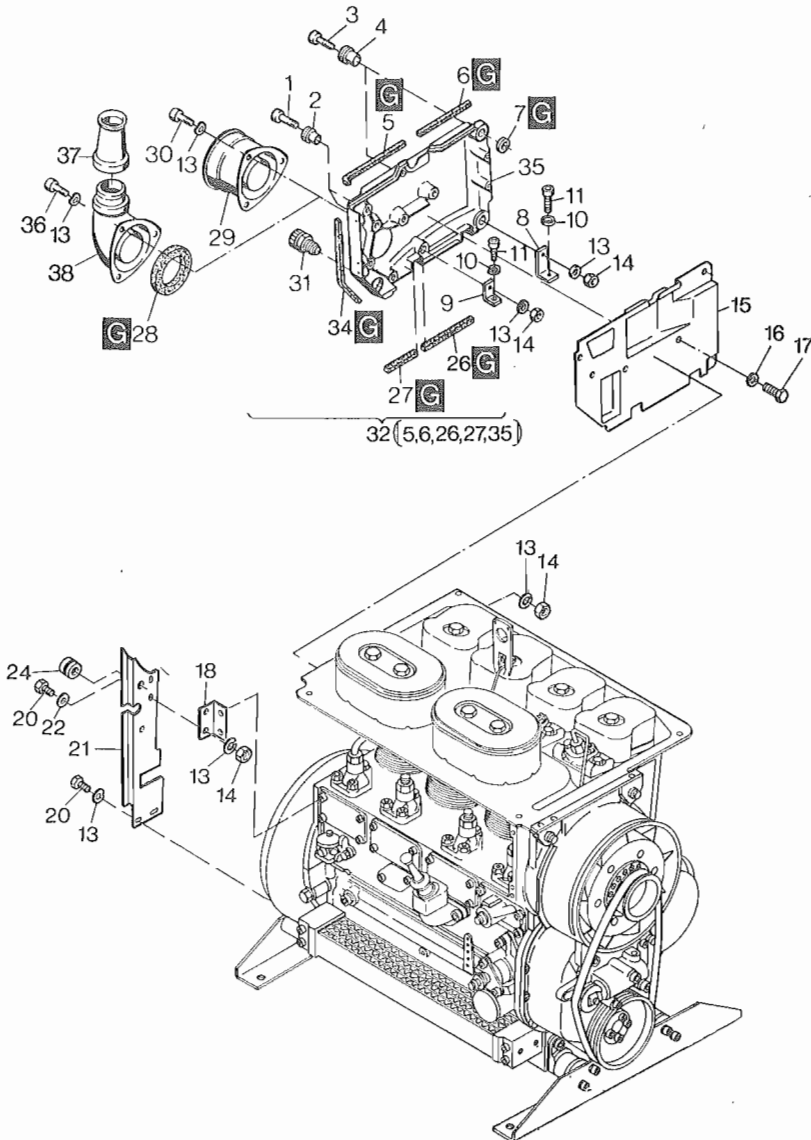

Fig. No.	Bestell-Nr.	Stück	Hinweise		
	Ordering No.	Quantity	Hints	Indications	
	No. référence	Quantites	Indications		
	No. de pedido	Cantidades	Indicaciones		
		2...4L...S/Z	2...4L...C/K		
1	500 510 00	2	2	M 6 x 30	DIN 912-8.8
2	009 327 00	2	2		
3	500 511 00	2	2	M 6 x 30	DIN 912-8.8
4	009 215 00	2	2		
5	035 637 01	1	1	214 mm	
6	035 651 00	1	1	113 mm	
7	035 755 00	4	4		
8	036 468 00	1	1		
9	036 469 00	1	1		
10	500 028 00	2	2	8	DIN 128
11	500 516 00	2	2	M 8 x 16	DIN 912-8.8
12	—	—	—		
13	500 812 00	4	8	A 6	DIN 137
14	500 227 00	4	6	M 6	DIN 933-8.8
15	036 462 01	1	1		
16	500 812 00	7	7	A 6	DIN 137
17	500 255 00	7	7	6 x 12	DIN 933-8.8
18	035 901 00	—	1		
19	—	—	—		
20	500 255 00	—	4	M 6 x 12	DIN 933-8.8
21	036 472 00	—	1		
22	501 445 00	—	2	6,4	DIN 125-St A3C
23	—	—	—		
24	035 654 00	—	1		
26	035 651 00	1	1	113 mm	
27	035 602 00	1	1	93 mm	
28	036 473 00	—	1		
29	009 537 00	1	1		
30	501 491 00	3	—	M 6 x 12	DIN 912-8.8 A3C
31	501 590 10	1	—		
32	009 532 00	1	1		
33	—	—	—		
34	036 463 00	—	1		
35	—	—	—		
36	501 707 00	—	3	M 6 x 16	DIN 912-8.8 A3C
37	037 803 00	—	1		
38	012 191 00	—	1		

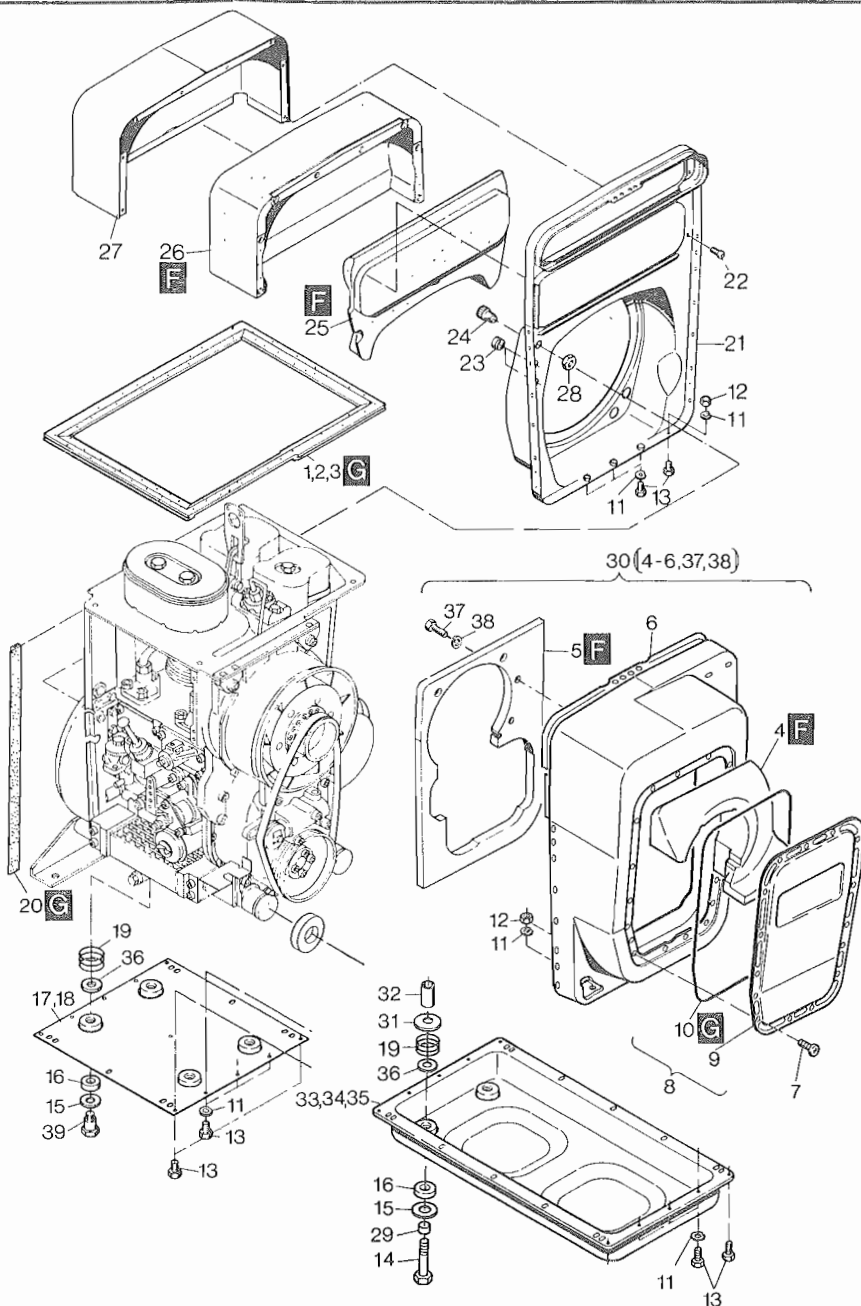

Fig. No.	Bestell-Nr. Ordering No. No. référence No. de pedido	Stück Quantity Quantites Cantidades			Hinweise Hints Indications Indicaciones	
		2 L...C	3 L...C	4 L...C		
1	036 160 01	1	—	—		
2	036 161 01	—	1	—		
3	036 162 01	—	—	1		
4	009 958 00	1	1	1		
5	035 850 02	1	1	1		
6	—	—	—	—		
7	502 892 00	17	17	17	M 6 x 12	SB - 8.8 A3D
8	009 985 00	1	1	1		
9	—	—	—	—		
10	037 654 00	1	1	1		
11	500 812 00	10	10	10	A6 DIN 137	A3C
12	500 227 00	4	4	4	M 6	DIN 934-8
13	500 254 00	10	10	10	M 6 x 10	DIN 933-8.8
14	501 430 00	4	4	4	M 12 x 95	DIN 931-8.8
15	036 373 00	4	4	4		
16	036 372 00	4	4	4		
17	037 528 00	1	—	—		
18	037 529 00	—	1	—		
19	035 949 00	4	4	4		
20	036 433 00	1	1	1		
21	009 697 00	1	1	1		
22	502 892 00	8	8	8	M 6 x 12	SB - 8.8 A3D
23	035 654 00	2	2	2		
24	501 590 10	1	1	1	NH 13,5	
25	036 474 00	1	1	1		
26	035 879 01	1	1	1		
27	009 111 01	1	1	1		
28	501 591 00	1	1	1	PG 13,5	
29	036 028 00	—	—	4		
30	009 503 10	1	1	1		
31	036 026 00	4	4	4		
32	036 029 00	4	4	4		
33	009 218 00	1	—	—		
34	009 219 00	—	1	—		
35	009 220 01	—	—	1		
36	035 952 00	4	4	4		
37	500 266 00	2	2	2	M 8 x 12	DIN 933-8.8
38	500 028 00	2	2	2	8	DIN 128
39	035 950 00	4	4	—		

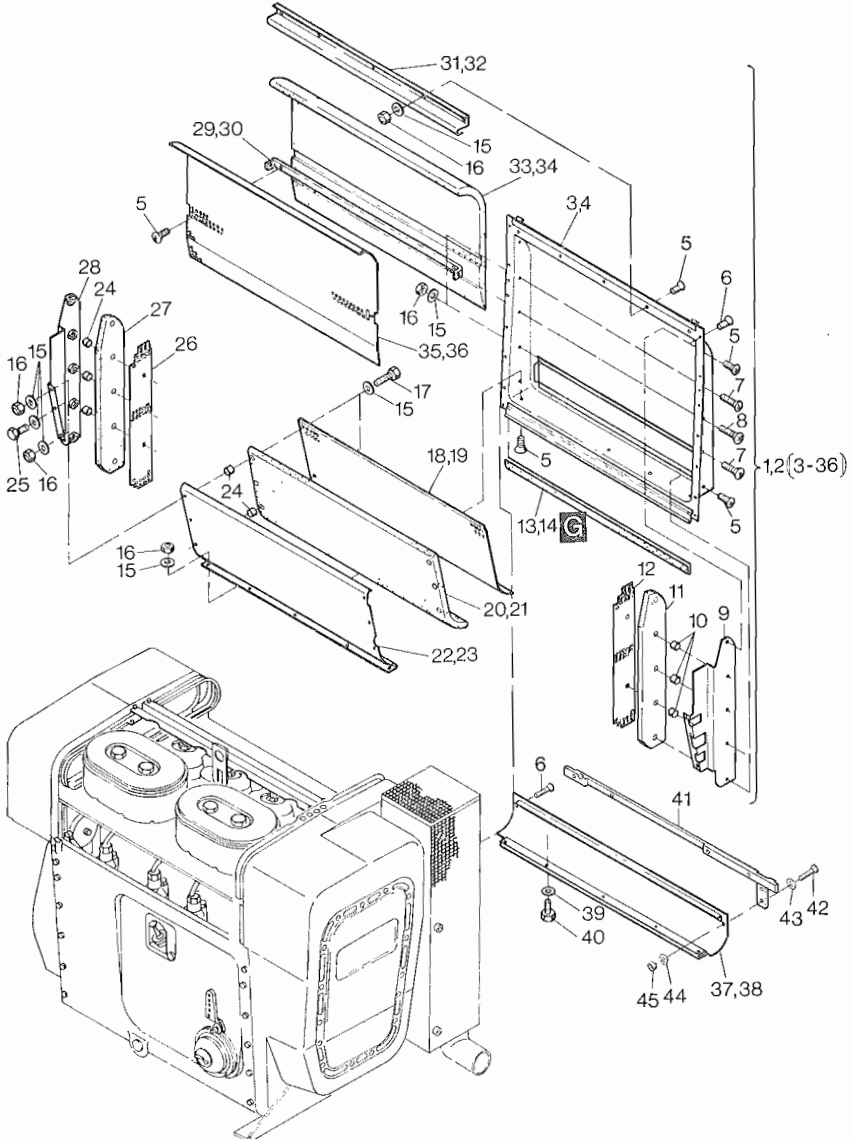

Fig. No.	Bestell-Nr. Ordering No. No. référence No. de pedido	Stück Quantity Quantities Cantidades		Hinweise Hints Indications Indicaciones	
		2 L...C	3 L...C		
1	009 256 01	1	—		
2	009 257 02	—	1		
3	007 480 01	1	—		
4	009 070 02	—	1		
5	502 892 00	10	13	M 6 x 12	SB - 8.8 A3D
6	502 892 00	14	14	M 6 x 12	SB - 8.8 A3D
7	501 385 00	4	4	M 6 x 30	DIN 7985-5.6
8	501 386 00	2	2	M 6 x 35	DIN 7985-5.6
9	009 084 01	1	1		
10	035 905 00	3	3		
11	035 871 01	1	1		
12	035 908 01	1	1		
13	035 933 00	1	—		
14	035 934 00	—	1		
15	501 445 00	22	24	6,4	DIN 125-St A3C
16	500 227 00	16	18	M 6	DIN 934-8
17	500 261 00	4	4	M 6 x 30	DIN 933-8.8
18	035 910 00	1	—		
19	035 912 00	—	1		
20	035 876 00	1	—		
21	035 877 00	—	1		
22	009 080 00	1	—		
23	009 081 00	—	1		
24	035 905 00	7	7		
25	500 255 00	2	2	M 6 x 12	DIN 933-8.8
26	035 908 01	1	1		
27	037 504 01	1	1		
28	009 083 01	1	1		
29	035 906 00	1	—		
30	035 913 00	—	1		
31	035 847 01	1	—		
32	035 848 01	—	1		
33	035 873 00	1	—		
34	035 874 00	—	1		
35	035 909 00	1	—		
36	035 911 00	—	1		

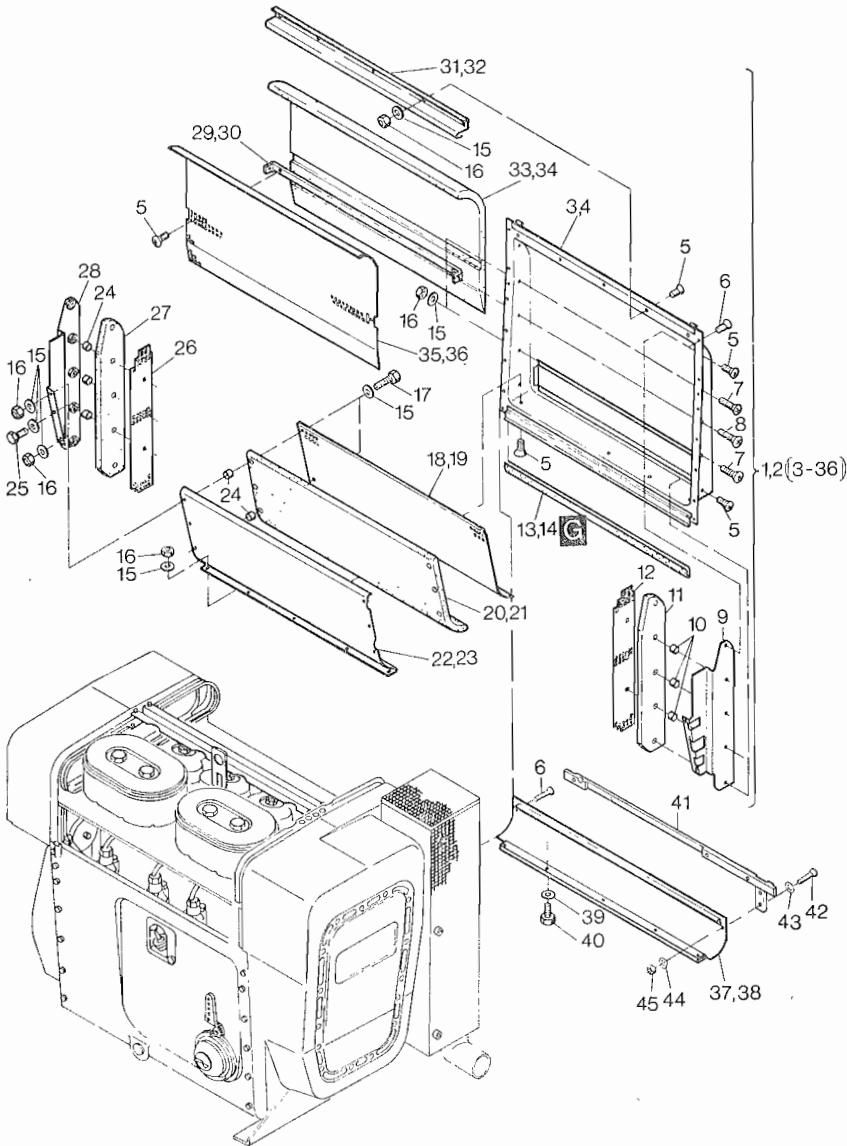

Fig. No.	Bestell-Nr. Ordering No. No. référence No. de pedido	Stück Quantity Quantites Cantidades		Hinweise Hints Indications Indicaciones	
		2 L...C	3 L...C		
37	009 499 00	1	—		
38	009 500 00	—	1		
39	500 166 00	3	4	6,4	DIN 125-St
40	500 254 00	3	4	M 6 x 10	DIN 933-8.8
41	011 196 00	—	1		
42	501 386 00	—	1	M 6x35	DIN 7985-5.6
43	501 445 00	—	1	6,4	DIN 125-St A3C
44	501 709 00	—	1	6	DIN 128 A3C
45	501 444 00	—	1	M 6	DIN 934-8 A3C

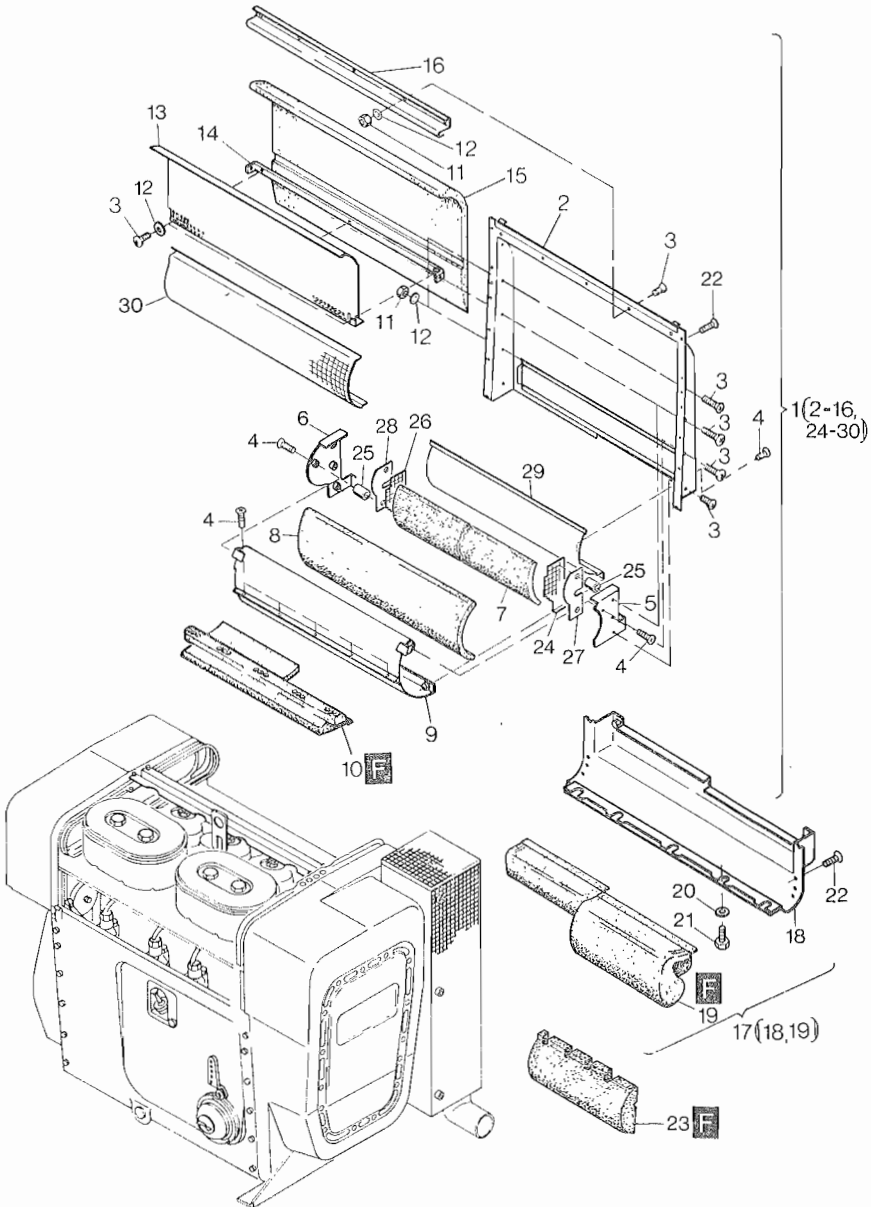

Fig. No.	Bestell-Nr. Ordering No. No. référence No. de pedido	Stück Quantity Quantities Cantidades	Hinweise Hints Indications Indicaciones	
4 L...C/K				
1	009 968 02	1		
2	009 960 10	1		
3	502 892 00	22	M 6 x 12	SB - 8.8 A3D
4	500 493 00	14	M 5 x 10	DIN 7985-8.8
5	009 962 00	1		
6	009 963 00	1		
7	037 768 00	1		
8	037 767 00	1		
9	009 964 01	1		
10	012 055 00	1		
11	500 227 00	7	M 6	DIN 934-8
12	501 445 00	10	6,4	DIN 125-St A3C
13	037 684 00	1		
14	037 683 00	1		
15	037 690 00	1		
16	037 677 01	1		
17	009 949 00	1		
18	—	—		
19	037 673 00	1		
20	500 166 00	5	6,4	DIN 125-St
21	500 254 00	5	M 6 x 10	DIN 933-8.8
22	502 892 00	14	M 6 x 12	SB - 8.8 A3D
23	037 687 00	1		
24	037 762 00	1		
25	037 763 00	6		
26	037 764 00	1		
27	037 765 00	1		
28	037 766 00	1		
29	037 761 00	1		
30	037 760 00	1		

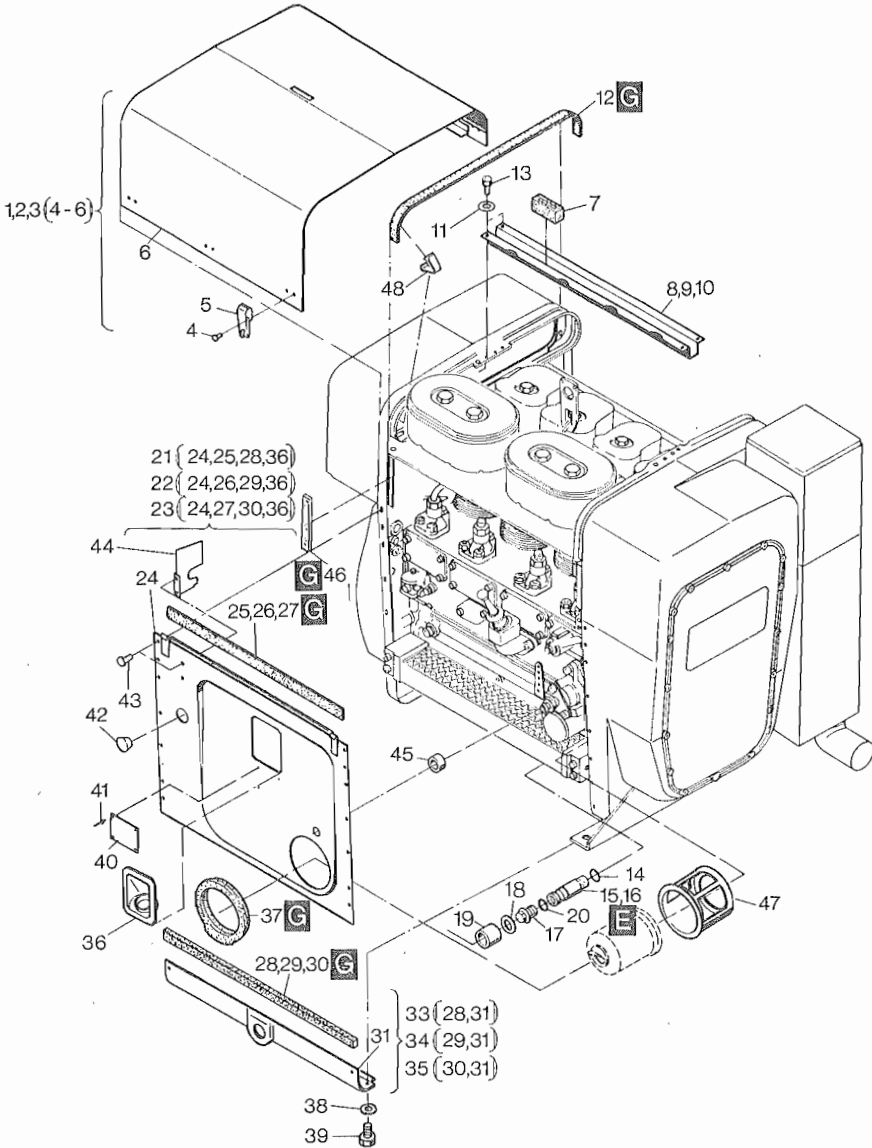

Fig. No.	Bestell-Nr.	Stück			Hinweise	
	Ordering No.	Quantity	Quantity	Quantity	Hints	
	No. référence	Quantites	Quantites	Quantites	Indications	
	No. de pedido	Cantidades	Cantidades	Cantidades	Indicaciones	
		2 L...C	3 L...C	4 L...C/K		
1	009 024 01	1	—	—		
2	009 068 01	—	1	—		
3	009 069 01	—	—	1		
4	501 402 00	8	8	12	3,5 x 8	DIN 660 MUST 34
5	401 213 10	4	4	6		
6	—	—	—	—		
7	035 690 00	1	1	1		
8	035 788 00	1	—	—		
9	035 826 00	—	1	—		
10	035 827 00	—	—	1		
11	500 812 00	4	4	4	A 6	DIN 137
12	035 776 00	2	2	2	650 mm	
13	501 330 00	4	4	4	M 6 x 12	DIN 6912-8.8
14	500 016 00 W4	1	1	1	A 22 x 27	DIN 7603-Cu
15	035 505 00	1	1	—		
16	036 030 00	1	1	1	f. Taf./Tabl. 32, Pos. 58-60	
16	036 475 00	1	1	1	f. Taf./Tabl. 32, Pos. 42-44	
17	500 442 00 W1	1	1	1	M 18 x 1,5	DIN 910
18	035 923 01	1	1	1		
19	035 795 00	1	1	1		
20	500 014 00 W4	1	1	1	A 18 x 22	DIN 7603-Cu
21	009 353 10	1	—	—		
22	010 969 00	—	1	—		
23	009 355 10	—	—	1		
24	—	—	—	—		
25	035 933 00	1	—	—		
26	035 934 00	—	1	—		
27	035 935 00	—	—	1		
28	036 237 10	1	—	—		
29	036 238 10	—	1	—		
30	036 239 10	—	—	1		
31	—	—	—	—		
32	—	—	—	—		
33	009 741 00	1	—	—		
34	009 742 00	—	1	—		
35	009 743 01	—	—	1		

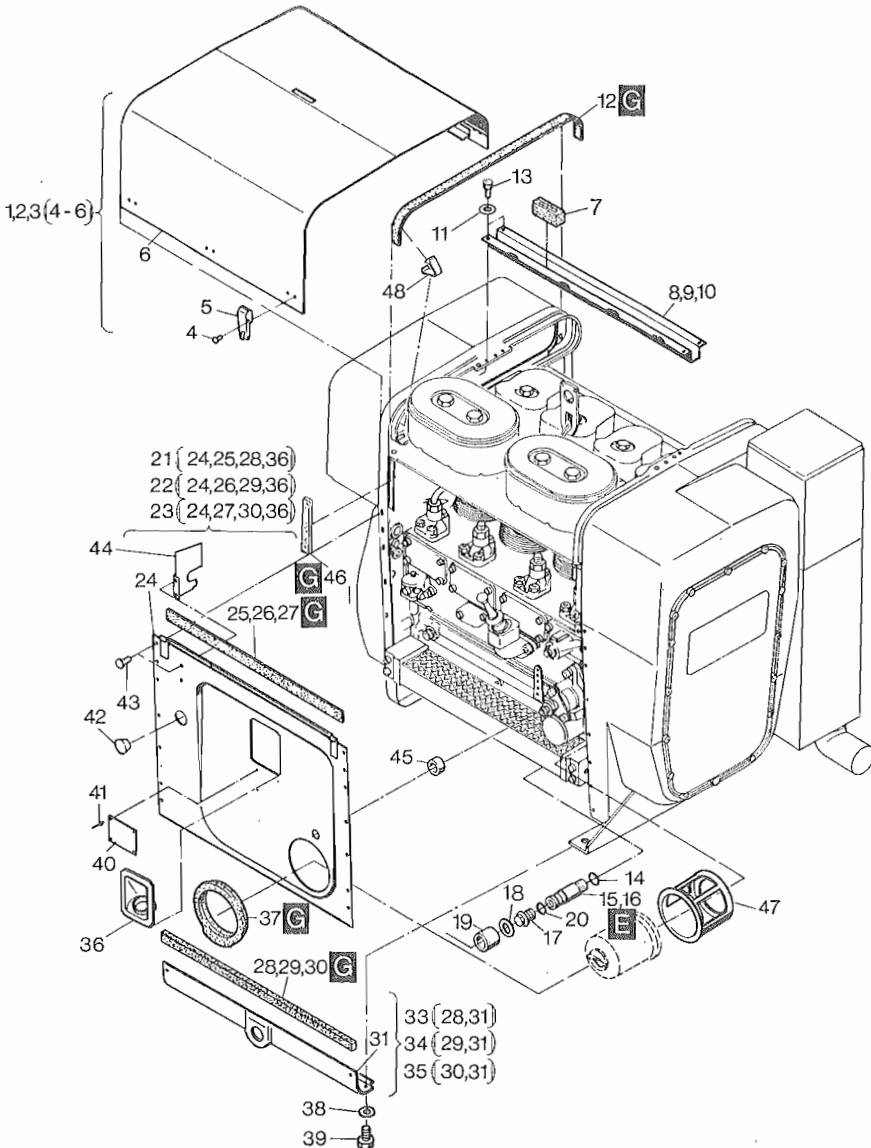

Fig. No.	Bestell-Nr. Ordering No. No. référence No. de pedido	Stück Quantity Quantites Cantidades			Hinweise Hints Indications Indicaciones	
		2 L... C	3 L... C	4 L... C/K		
36	037 614 00	1	1	1		
37	035 940 01	1	1	1		
38	500 166 00	3	4	5	6,4	DIN 125-St
39	500 254 00	3	4	5	M 6 x 10	DIN 933-8.8
40	032 255 03	1	1	1		
41	400 025 00	4	4	4		
42	037 693 01	1	1	1		
43	502 892 00	12	12	14	M 6 x 12	SB - 8.8 A3D
44	036 020 00	—	—	1		
45	035 794 00	1	1	1		
46	035 772 00	2	2	2	125 mm	
47	009 243 00	1	1	1		
48	037 799 00	4	4	4		

A 01

Kraftstoff
Fuel
Carburant
Combustible

Tafel Nr.
Tabl. No.

24

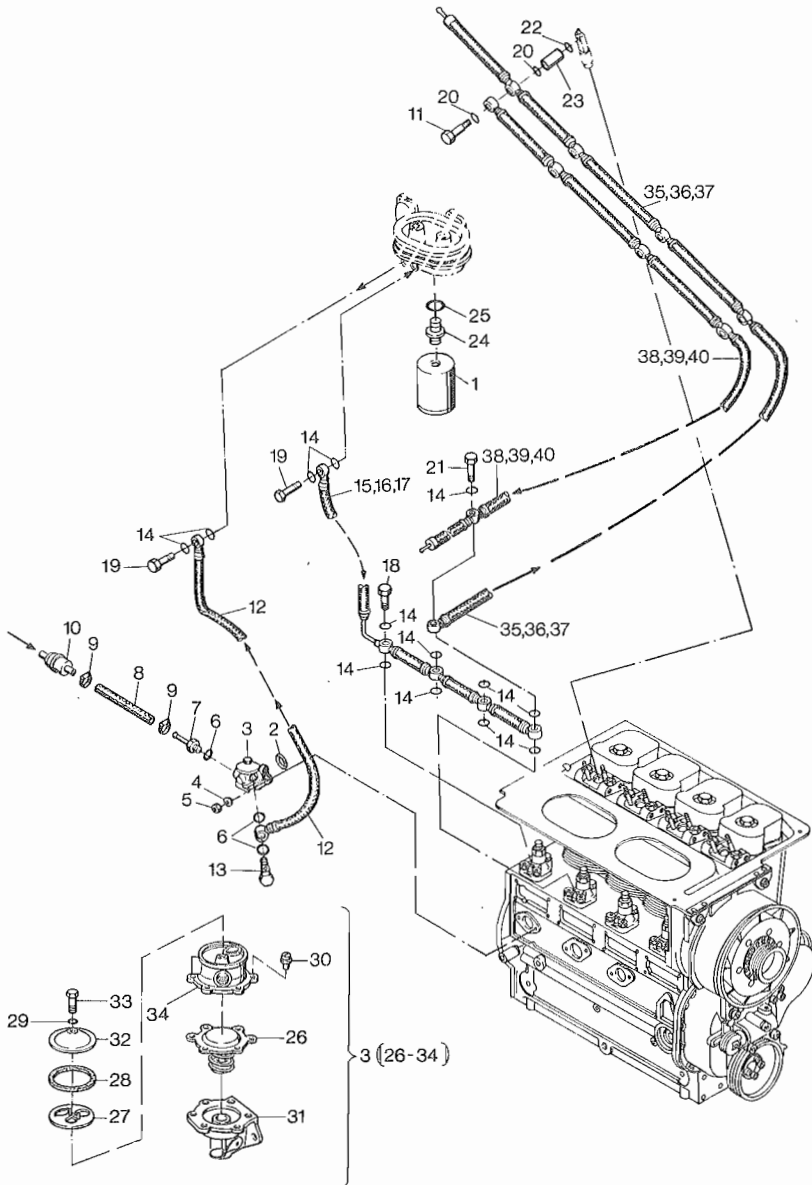

Fig. No.	Bestell-Nr.	Stück			Hinweise	
	Ordering No.	Quantity			Hints	
	No. référence	Quantities			Indications	
	No. de pedido	Cantidades			Indicaciones	
		2 L...	3 L...	4 L...		
1	502 515 00 W2	1	1	1		
2	501 299 00	1	1	1		
3	401 204 00	1	1	1		
4	500 812 00	2	2	2	A 6	DIN 137
5	500 227 00	2	2	2	M 6	DIN 934-8
6	500 012 00	3	3	3	A 14 x 18	DIN 7603-Cu
7	034 668 00	1	1	1		
8	034 933 00	1	1	1		
9	400 373 00	2	2	2		
10	503 170 00 W2	1	1	1		
11	034 602 00	2	3	4		
12	035 733 01	1	1	1		
13	500 064 00	1	1	1	10-3	DIN 7643
14	500 011 00	9	11	13	A 12 x 15,5	DIN 7603-Cu
15	038 365 00	1	—	—		
16	038 366 00	—	1	—		
17	038 367 00	—	—	1		
18	036 134 00	1	2	2		
19	500 063 00	2	2	2	8-13	DIN 7643
20	500 009 00	4	6	8	A 8 x 11,5	DIN 7603-Cu
21	038 906 00	—	—	1		
21	036 397 00	1	1	—		
22	500 008 00	2	3	4	A 6,5 x 9,5	DIN 7603-Cu
23	035 739 00	2	3	4		
24	502 533 00	1	1	1	A LL 10	DIN 7647
25	500 012 00	1	1	1	A 14 x 18	DIN 7603-Cu
26	490 182 00	1	1	1		
27	490 183 00	1	1	1		
28	490 184 00	1	1	1		
29	490 185 00	1	1	1		
30	490 181 00	6	6	6		
31	—	—	—	—		
32	—	—	—	—		
33	—	—	—	—		
34	—	—	—	—		
35	008 063 00	1	—	—	„S/Z“	
36	008 061 00	—	1	—	„S/Z“	
37	008 060 00	—	—	1	„S/Z“	
38	008 022 00	1	—	—	„C“	
39	008 024 00	—	1	—	„C“	
40	008 025 00	—	—	1	„C/K“	

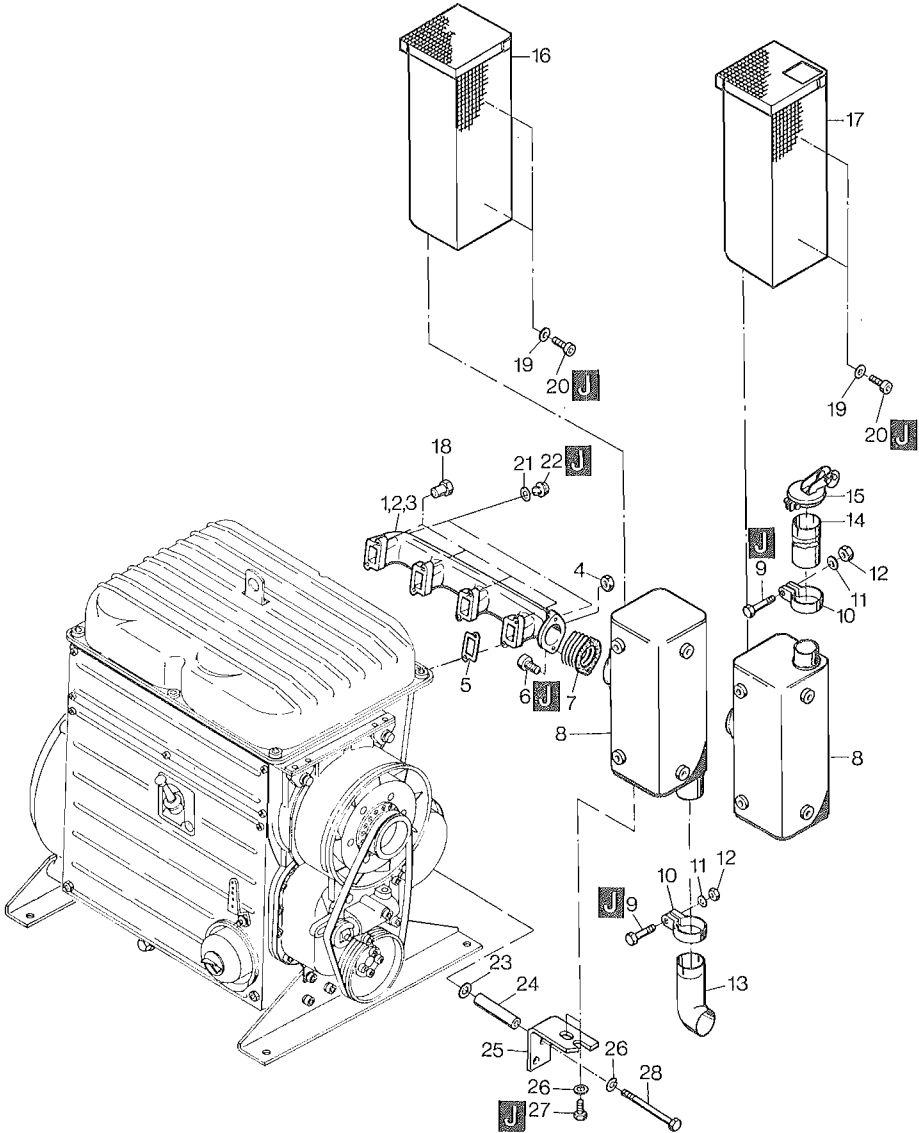

Fig. No.	Bestell-Nr. Ordering No. No. référence No. de pedido	Stück Quantity Quantites Cantidades			Hinweise Hints Indications Indicaciones	
		2 L...S/Z	3 L...S/Z	4 L...S/Z		
1	036 251 00	1	—	—		
2	036 319 00	—	1	—		
3	036 320 00	—	—	1		
4	400 284 00 P2	2	3	4	M 8	SSN 440-8 Cu
5	036 245 00	2	3	4		
6	502 250 00	2	2	2	M 10 x 30	DIN 912-10.9 C4P
7	501 659 01	5	5	5		
8	011 091 00	1	1	1		
9	500 301 00	1	1	1	M 10 x 65	DIN 931-8.8
10	038 778 00	1	1	1		
11	500 169 00	1	1	1	8,4	DIN 125-St
12	400 286 00	1	1	1	M 10	SSN 440-8 Cu
13	038 856 00	1	1	1		
14	038 896 00	1	1	1		
15	501 569 00	1	1	1		
16	010 914 00	1	1	1		
17	038 858 00	1	1	1	8	DIN 128
18	036 252 00 P2	2	3	4		
19	501 200 00	6	6	6	A 6,4	DIN 9021-St A3C
20	501 390 00	6	6	6	M 6 x 10	DIN 912-8.8 C4P
21	032 288 00	2	3	4		
22	500 447 00	2	3	4	R 1/4	DIN 910
23	500 629 00	2	2	2	8,4	DIN 9021-St A3C
24	035 387 01	2	2	2	9 x 14 x 42	
25	039 229 00	1	1	1		
26	501 481 00	4	4	4	8,4	DIN 125-St A3C
27	501 376 00	2	2	2	M 8 x 20	DIN 933-8.8 C4P
28	500 879 00	2	2	2	M 8 x 70	DIN 931-8.8

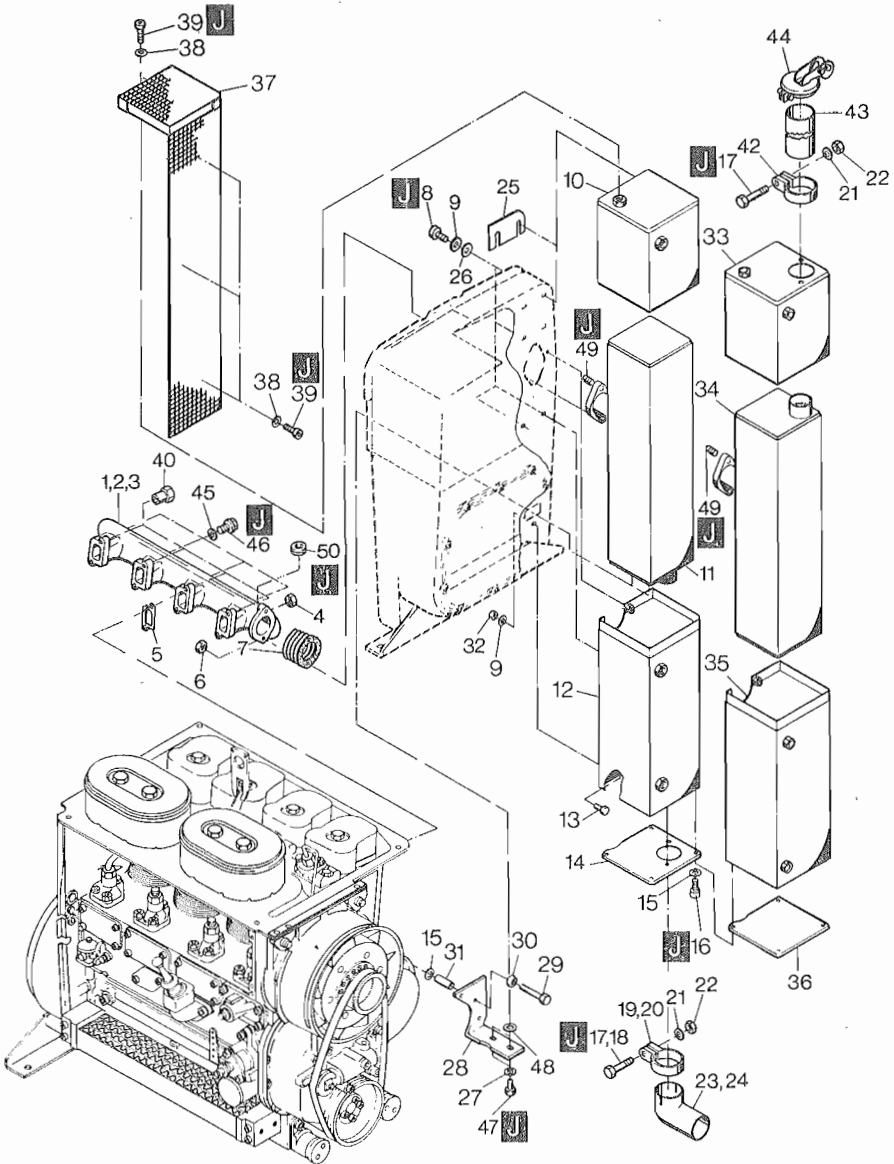

Fig. No.	Bestell-Nr. Ordering No. No. référence No. de pedido	Stück Quantity Quantites Cantidades			Hinweise Hints Indications Indicaciones	
		2 L...C	3 L...C	4 L...C/K		
1	037 704 00	1	—	—		
2	037 705 00	—	1	—		
3	037 686 00	—	—	1		
4	400 284 00 P2	2	3	4	M 8	SSN 440-8 Cu
5	036 245 00	2	3	4		
6	400 286 00	2	2	2	M 10	SSN 440-8 Cu
7	501 659 00	5	5	5		
8	502 557 00	7	7	7	M 6 x 12	DIN 912.8.8 C4A
9	500 027 00	7	7	7	6	DIN 128
10	009 029 01	1	1	1		
11	037 419 01	1	1	—		
11	038 299 01	—	—	1		
12	008 718 01	1	1	1		
13	500 255 00	1	1	1	M 6 x 12	DIN 933-8.8
14	038 779 00	1	1	1		
15	500 167 00	7	7	7	8,4	DIN 125-St
16	501 389 00	4	4	4	M 8 x 12	DIN 912-8.8
17	502 495 00	1	1	—	M 10x50	DIN 931-8.8 A3C
18	500 301 00	—	—	1	M 10 x 65	DIN 931-8.8
19	038 777 00	1	1	—	52,5	
20	038 778 00	—	—	1	58,5	
21	501 459 00	1	1	1	B 10,5	DIN 125-St A3C
22	400 286 00	1	1	1	SSN 440-8 Cu	
23	038 775 00	1	1	—	52,5	
24	038 776 00	—	—	1		
25	038 554 00	0...4	0...4	0...4		
26	500 166 00	8	8	8	6,4	DIN 125-St
27	500 629 00	2	2	2	B 8,4	DIN 9021-50
28	035 386 01	1	1	1		
29	500 879 00	3	3	3	M 8 x 70	DIN 931-8.8
30	500 028 00	3	3	3	8	DIN 128
31	035 387 01	3	3	3		
32	500 227 00	1	1	1	M 6	DIN 934-8
33	010 830 00	1	1	1		
34	038 838 00	1	1	1		
35	008 718 00	1	1	1		

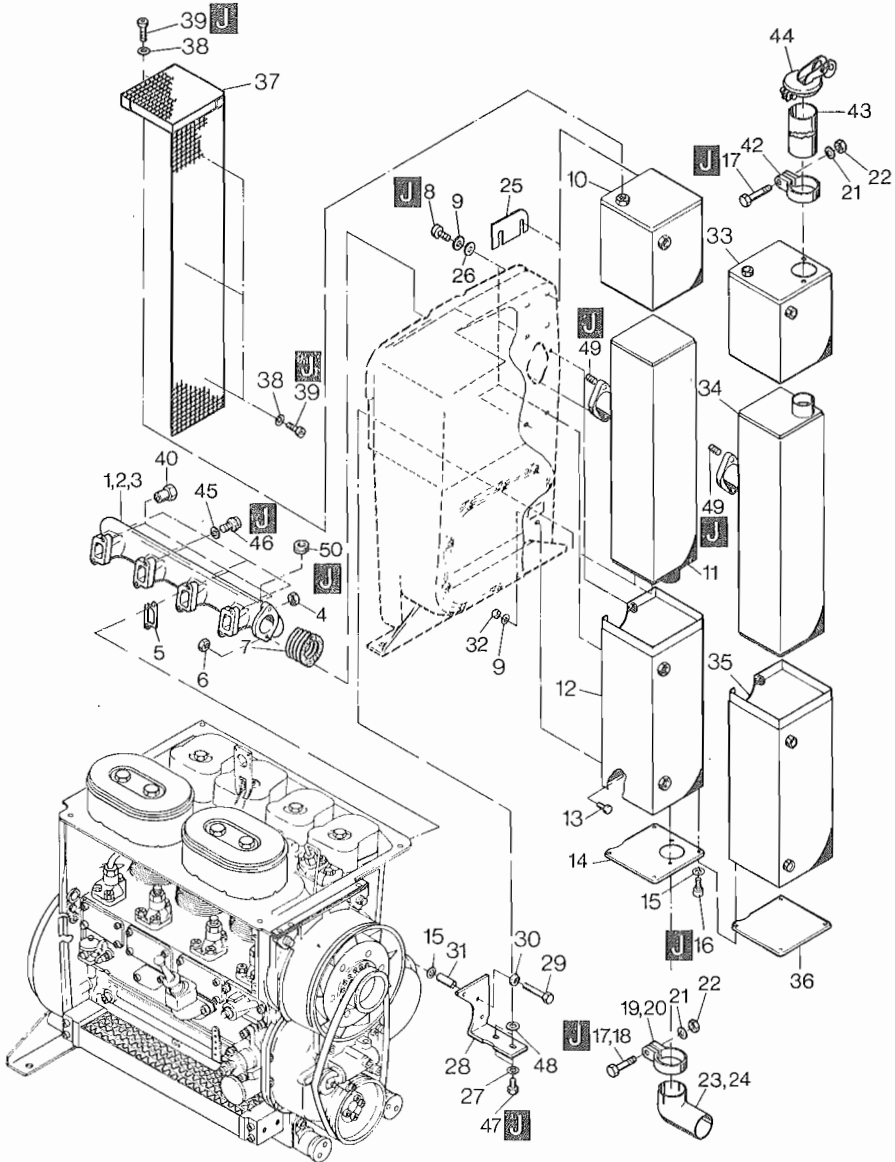

Fig. No.	Bestell-Nr. Ordering No. No. référence No. de pedido	Stück Quantity Quantites Cantidades			Hinweise Hints Indications Indicaciones	
		2 L...C	3 L...G	4 L...C/K		
36	038 780 00	1	1	1		
37	008 492 00	1	1	1		
38	501 209 00	7	7	7	A 6,4	DIN 9021-St Zn
39	501 390 00	7	7	7	M 6 x 10	DIN 912-8.8 C4P
40	036 252 00 P2	2	3	4		
41	—	—	—	—		
42	038 777 00	1	1	1	52,5	
43	038 897 00	1	1	1		
44	502 797 00	1	1	1		
45	032 288 00	2	3	4		
46	500 447 00	2	3	4	R 1/4	DIN 910
47	501 376 00	2	2	2	M 8 x 20	DIN 933-8.8 C4P
48	032 131 00	0...6	0...6	0...6		
49	500 408 00	2	2	2	M 10 x 28	DIN 939-10.9
50	502 781 00	1	1	1	R 1/4	DIN 906-5.8

A 04

Startfreigabe
Start release device
D blocage demarrage
Disparo de arranque

Tafel Nr.
Tabl. No.

27

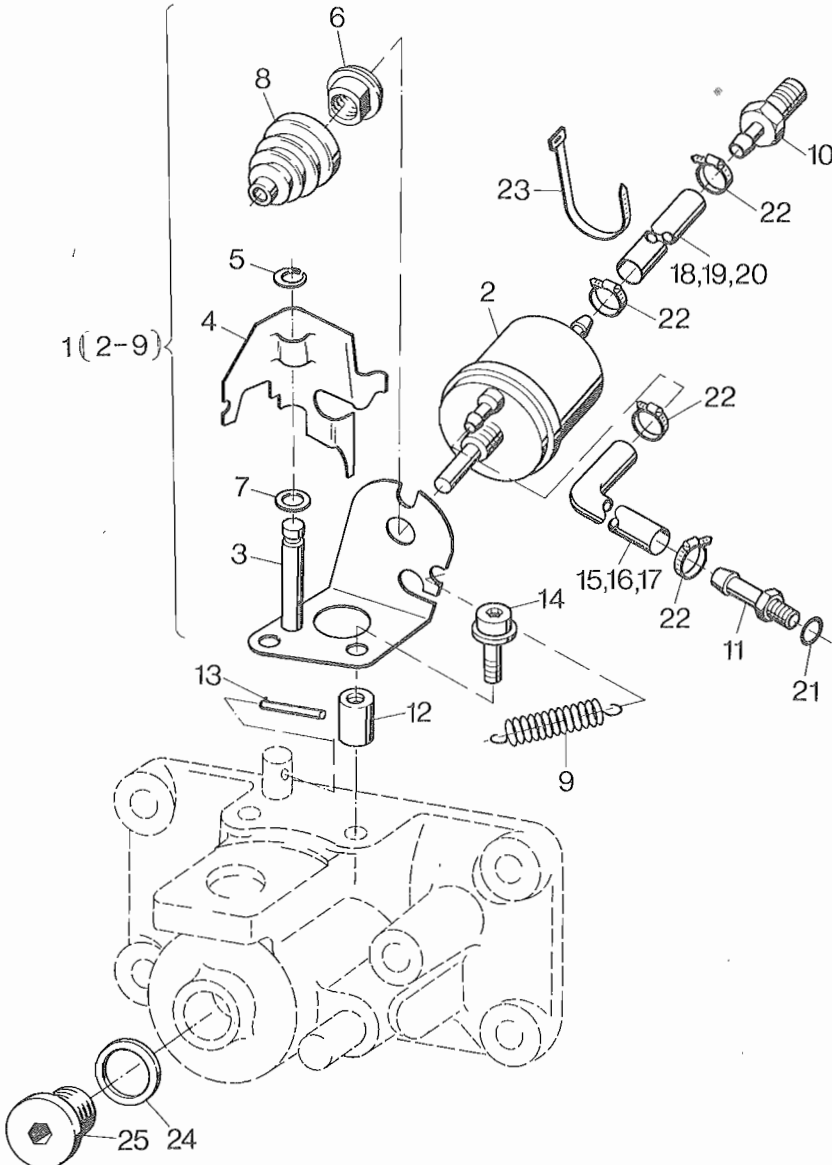

Fig. No.	Bestell-Nr. Ordering No. No. référence No. de pedido	Stück Quantity Quantites Cantidades			Hinweise Hints Indications Indicaciones	
		2 L...	3 L...	4 L...		
1	011 232 00	1	1	1		
2	011 059 00	1	1	1		
3	011 060 00	1	1	1		
4	038 985 00	1	1	1		
5	501 172 00	1	1	1	4	DIN 6799
6	039 220 00	1	1	1		
7	501 445 00	1	1	1	6,4	DIN 125-St A3C
8	501 804 00	1	1	1		
9	502 860 00	1	1	1		
10	011 061 00	1	1	1		
11	038 978 00	1	1	1		
12	039 219 00	2	2	2	7x14x12	
13	500 343 00	1	1	1	3x36	DIN 1481
14	501 944 00	2	2	2	M 6x25	A3C
15	038 992 00	1	—	—	270 mm	
16	039 020 00	—	1	—	390 mm	
17	039 021 00	—	—	1	540 mm	
18	038 993 00	1	—	—	400 mm	
19	039 021 00	—	1	—	540 mm	
20	039 022 00	—	—	1	640 mm	
21	503 167 00	1	1	1		
22	400 934 00	4	4	4		
23	501 674 00	1	1	1		
24	500 012 00	1	1	1	14 x 18	DIN 7603-Cu
25	501 435 00	1	1	1	M 14 x 1,5	DIN 908

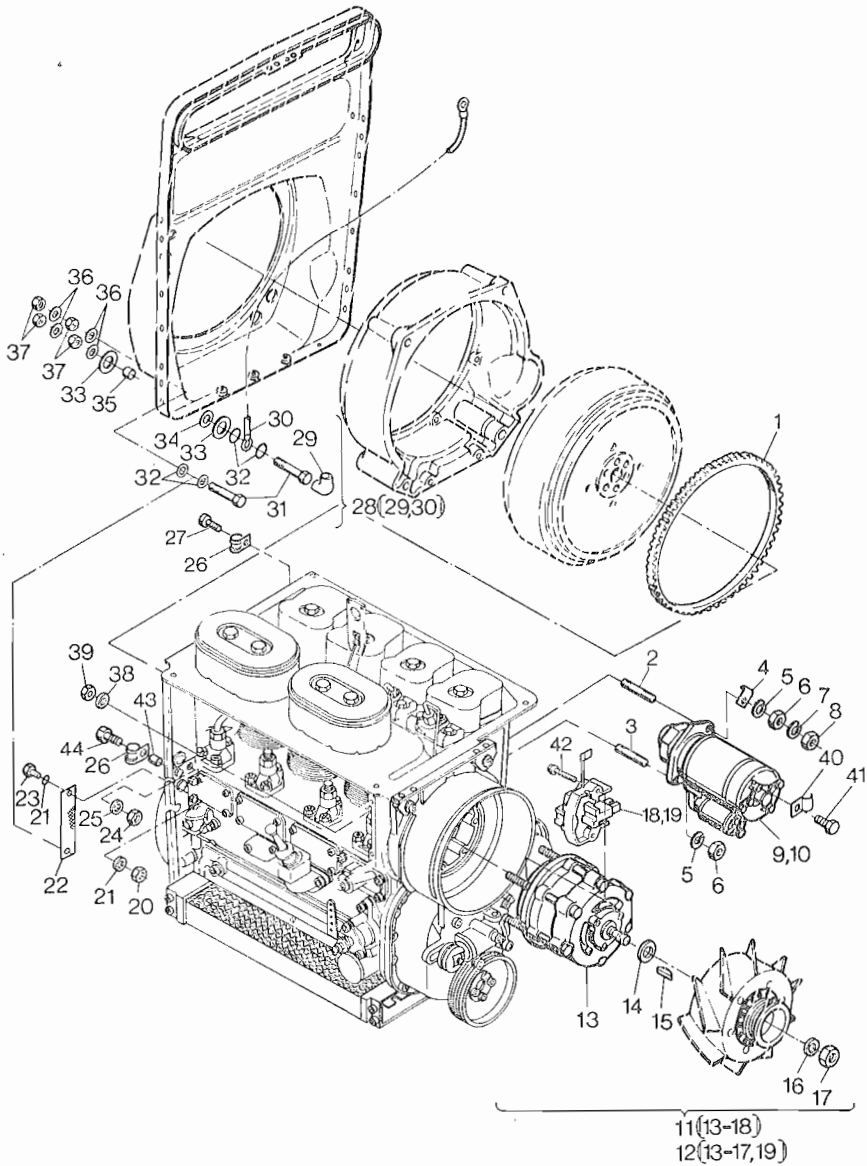

Fig. No.	Bestell-Nr.	Stück	Hinweise	
	Ordering No.	Quantity	Hints	
	No. référence	Quantities	Indications	
	No. de pedido	Cantidades	Indicaciones	
		2...4L...S/Z	2...4L...C/K	
1	031 561 01	1	1	
2	032 868 00	1	1	
3	500 423 00	1	1	M 12 x 25 DIN 938-5.6
4	036 896 10	—	1	
5	500 030 00	2	2	12 DIN 128
6	500 239 00	2	2	M 12 DIN 934-8
7	500 632 00	1	—	12
8	500 635 00	1	—	M 12 DIN 936-5 GAL
9	501 835 00	1	1	12 V 2,7 KW
10	501 954 00	1	1	24 V 4,0 KW
11	401 210 01	1	1	14 V 50 A
12	501 649 01	1	1	28 V 40 A
13	—	—	—	
14	—	—	—	
15	500 178 00	1	1	4 x 6,5 DIN 6888
16	—	—	—	
17	490 536 00	1	1	
18	490 538 00	1	1	12 V
19	490 539 00	1	1	24 V
20	501 480 00	—	1	M 8 DIN 934-8 A3C
21	501 481 00	—	2	8,4 DIN 125-St A3C
22	036 928 00	—	1	
23	500 985 00	—	1	M 8 x 16 DIN 933-8.8 A3C
24	501 444 00	—	2	M 6 DIN 934-8 A3C
25	500 812 00	—	2	A 6 DIN 137 A3C
26	501 584 00	—	3	
27	501 771 00	—	2	M 6 x 16 DIN 933-8.8 A3C
28	008 173 00	—	1	
29	400 266 00	—	1	
30	—	—	—	
31	500 274 00	—	1	M 8 x 30 DIN 933-MS
32	501 799 00	—	4	J 8,2 Zn DIN 6797
33	038 141 00	—	2	
34	501 798 00	—	1	A 10,5 Zn DIN 6797
35	038 142 00	—	1	
36	500 168 00	—	4	8,4 DIN 125-MS

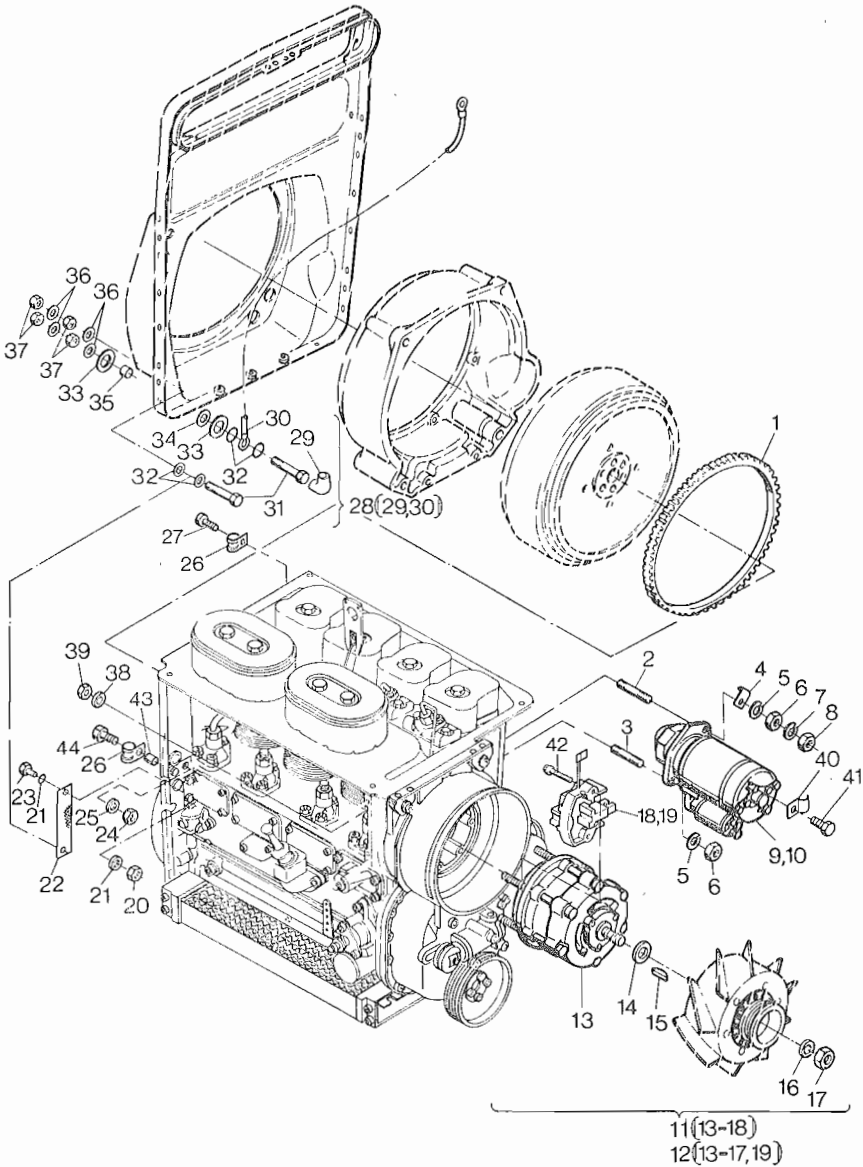

Fig. No.	Bestell-Nr.	Stück		Hinweise	
	Ordering No.	Quantity	Quantity	Hints	
	No. référence	Quantites	Quantites	Indications	
	No. de pedido	Cantidades		Indicaciones	
		2...4L...S/Z	2...4L...C/K		
37	500 230 00	—	4	M 8	DIN 934-MS
38	500 812 00	6	6	A 6	DIN 137 A3C
39	501 444 00	6	6	M 6	DIN 934-8 A3C
40	501 584 00	1	1		
41	501 655 00	1	1	M 6 x 12	DIN 933-8.8 A3C
42	—	—	—		
43	030 427 00	—	1		
44	501 687 00	—	1	M 6 x 35	DIN 931-8.8 A3C

1 (3-18, 20, 23-26, 28-41, 43)
 2 (3-18, 20, 23-25, 27-40, 42, 44)

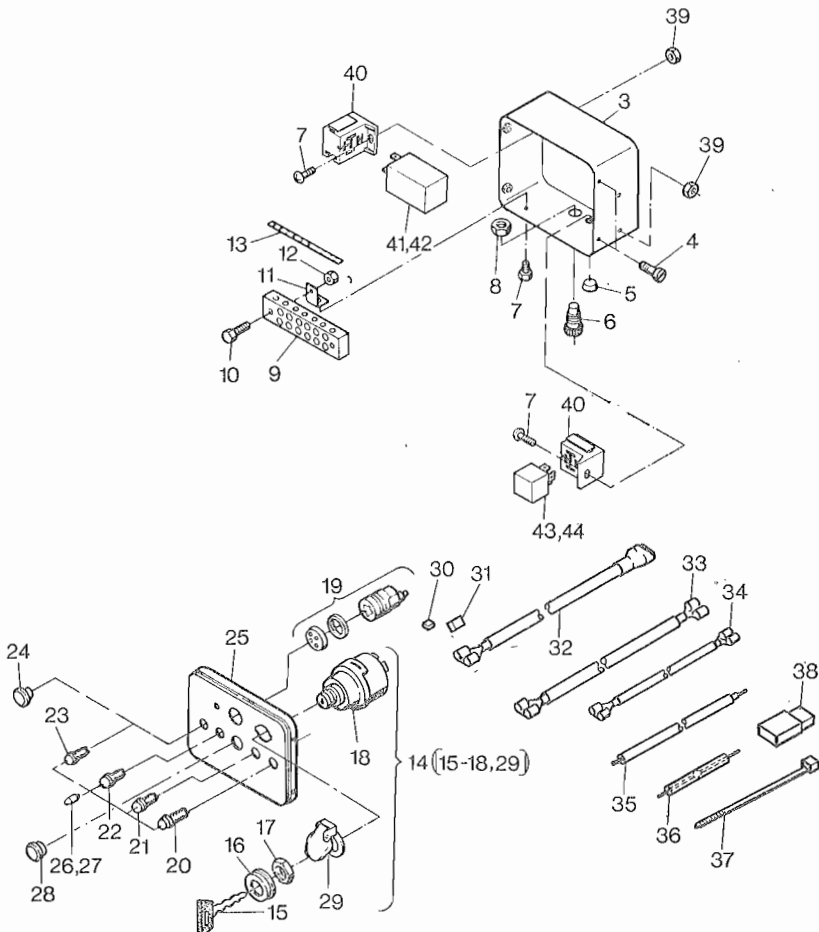

Fig. No.	Bestell-Nr. Ordering No. No. référence No. de pedido	Stück Quantity Quantités Cantidades			Hinweise Hints Indications Indicaciones
		2L...	3L...	4L...	
1	008 262 04	1	1	1	12 V
2	008 236 04	1	1	1	24 V
3	007 163 11	1	1	1	
4	502 892 00	4	4	4	M 6 x 12 SB-8.8 A3D
5	501 608 00	2	2	2	
6	501 590 10	1	1	1	
7	500 493 00	4	4	4	M 5 x 10 DIN 7985-4.8 A3R
8	501 591 00	1	1	1	
9	501 607 00	1	1	1	
10	501 588 00	2	2	2	M 4 x 20 DIN 84-4.8 A3C
11	036 667 00	2	2	2	
12	501 471 00	2	2	2	M 4 DIN 934-8 A3C
13	036 717 01	1	1	1	
14	502 765 00	1	1	1	
15	501 664 00 P1	1	1	1	
16	—	—	—	—	
17	—	—	—	—	
18	—	—	—	—	
19	400 686 00	1	1	1...2	4 L...: 12V (2) 24V (1)
20	501 765 00	1	1	1	BATT
21	501 766 00	1	1	1	OIL
22	501 764 00	1	1	1	TEMP
23	501 824 00	1	1	1	FILTER
24	400 960 00	0...2	0...2	0...2	F 17
25	035 092 11	1	1	1	
26	400 097 00	4	4	4	12 V 2 W
27	400 098 00	4	4	4	24 V 2 W
28	400 914 00	0...2	0...2	0...2	F 24
29	490 509 00	1	1	1	
30	502 766 00	1	1	1	4 - P
31	502 767 00	1	1	1	6 - P
32	008 182 02	1	1	1	
33	010 898 00	1	1	1	
34	010 899 00	1	1	1	
35	010 902 00	1	1	1	
36	400 280 00	1	1	1	

- 1 (3-18, 20, 23-26, 28-41, 43)
 2 (3-18, 20, 23-25, 27-40, 42, 44)

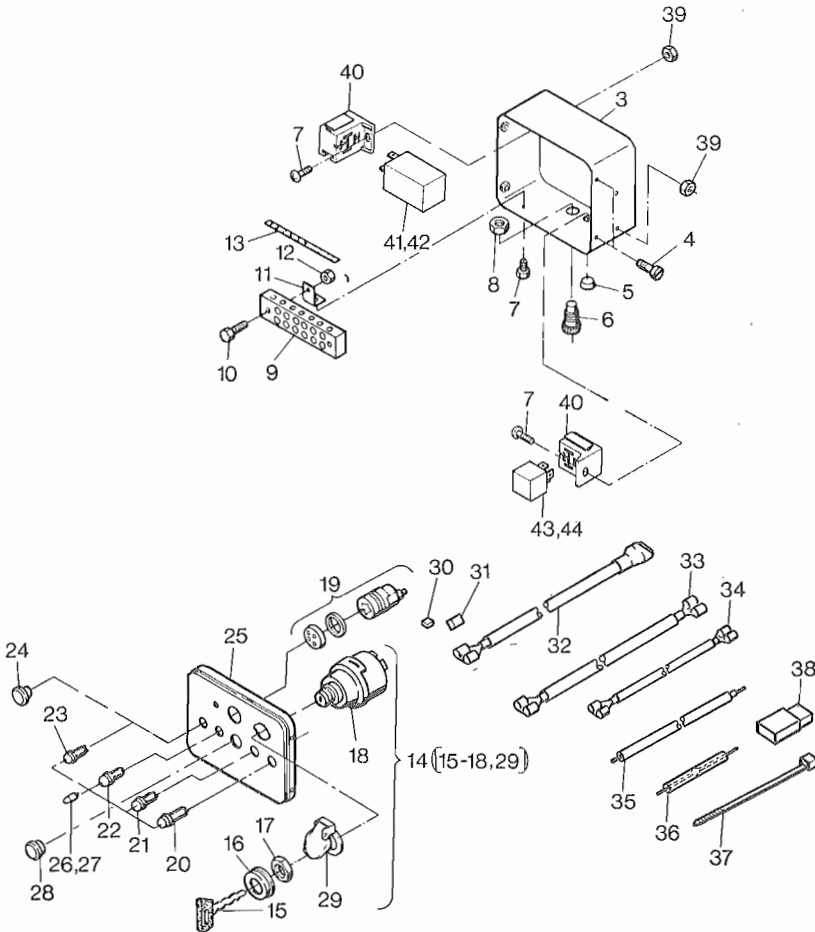

Fig. No.	Bestell-Nr. Ordering No. No. référence No. de pedido	Stück Quantity Quantites Cantidades			Hinweise Hints Indications Indicaciones
		2 L...	3 L...	4 L...	
37	501 674 00	3	3	3	
38	501 907 00	1	1	1	
39	400 282 00	2	2	2	
40	502 760 00	2	2	2	
41	502 758 01	1	1	1	12 V HATZ
42	502 759 01	1	1	1	24 V
43	502 777 01	1	1	1	12 V Bosch
44	502 778 01	1	1	1	24 V Bosch

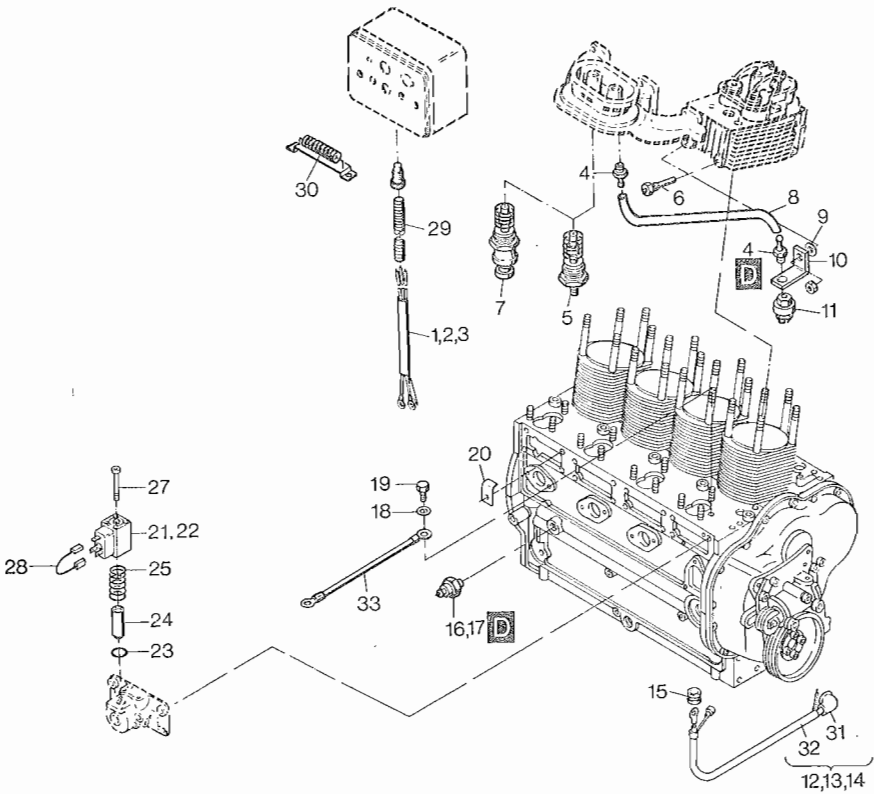

Fig. No.	Bestell-Nr. Ordering No. No. référence No. de pedido	Stück Quantity Quantites Cantidades			Hinweise Hints Indications Indicaciones
		2 L...	3 L...	4 L...	
1	008 218 00	1	—	—	
2	008 219 01	—	1	—	
3	008 175 01	—	—	1	
4	501 677 00	2	2	2	
5	501 639 00	1	1	1...2	184 G 4 L...: 12V (2) 24V (1)
6	502 686 00	1	1	1	TEMP
7	501 641 00	—	—	1	400 G 24V
8	036 937 00	1	1	1	
9	500 167 00	1	1	1	8,4 DIN 125-St
10	036 936 00	1	1	1	
11	501 676 00	1	1	1	
12	008 253 01	1	—	—	
13	008 206 01	—	1	—	
14	008 203 01	—	—	1	
15	501 585 00	1	1	1	
16	400 213 00	1	1	1	OIL
17	502 722 00	—	—	1	4 L 40 C/K OIL
18	500 167 00	1	1	1	8,4 DIN 125-St
19	500 267 00	1	1	1	M 8 x 16 DIN 933-8.8
20	036 666 00	2	2	2	
21	038 668 02	1	1	1	12V
22	038 669 02	1	1	1	24V
23	502 750 00	1	1	1	14x 1,78
24	038 976 00	1	1	1	
25	038 977 00	1	1	1	
27	502 699 00	2	2	2	M 4 x 35 DIN 912-8.8 A3C
28	—	—	—	—	
29	036 682 10	1	1	1	2000 mm
30	400 883 00	—	—	1	24V
31	400 266 00	1	1	1	
32	—	—	—	—	
33	008 171 00	1	1	1	

A 06 Motorfüße
 Engine brackets
 Pieds moteur
 Soportes del mot.

A 12 Riemenschutz
 Belt guard
 Protect. courroie
 Protec. corea

A 15 Anschlußgeh.
 Intern. housing
 Bride raccord
 Caja de con.

Tafel Nr.
 Tabl. No.
 31

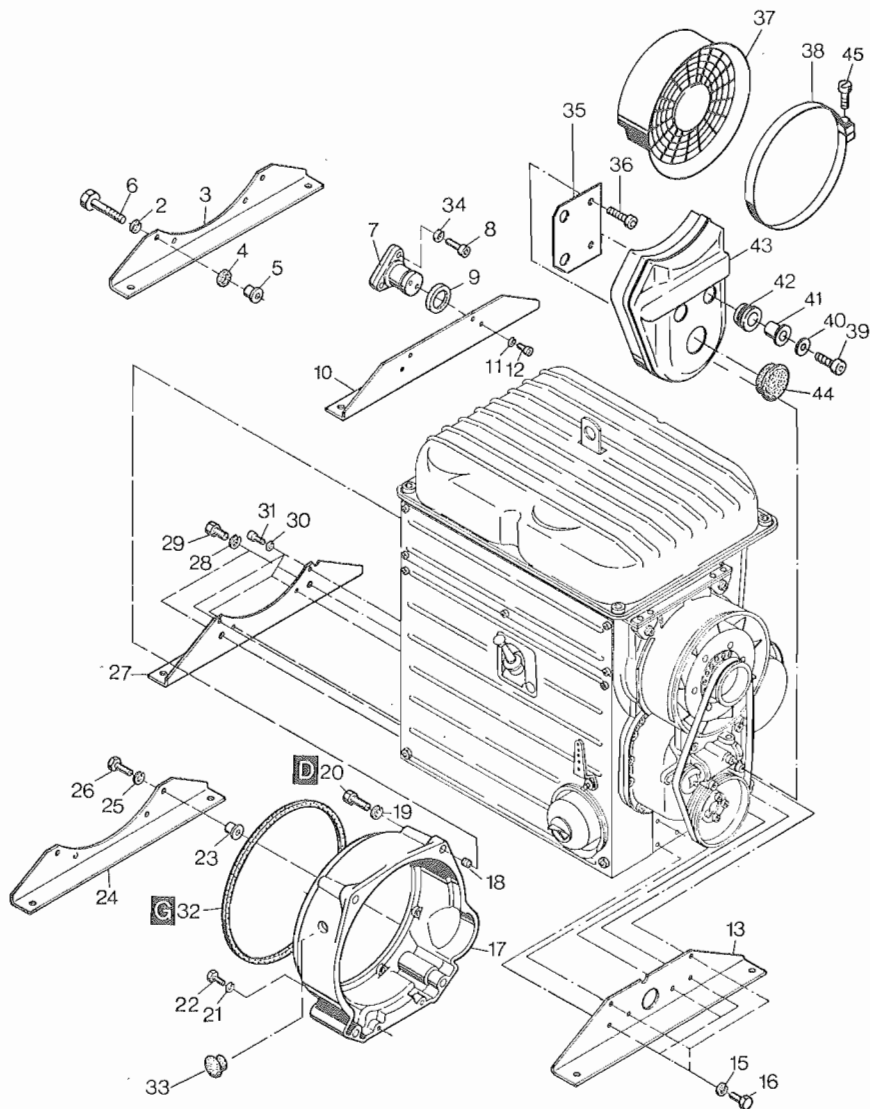

Fig. No.	Bestell-Nr.	Stück	Hinweise	
	Ordering No.	Quantity	Hints	
	No. référence	Quantités	Indications	
	No. de pedido	Cantidades	Indicaciones	
		2...4L...S/Z	2...4L...C/K	
1	—	—	—	
2	500 632 00	—	4	12 DIN 128 A3C
3	038 787 00	—	1	
4	035 798 00	—	4	
5	035 791 00	—	4	
6	502 593 00	—	4	M 12x110 DIN 931-8.8 A3C
7	007 393 01	—	2	
8	500 730 00	—	4	M 12 x 40 DIN 912-12.9
9	035 799 00	—	2	
10	038 789 00	—	1	
11	501 356 00	—	4	10 DIN 128 A3C
12	501 365 00	—	4	M 10x20 DIN 931-8.8 A3C
13	038 786 00	1	—	
14	—	—	—	
15	500 030 00	6	—	12 DIN 128
16	500 311 00	6	—	M 12 x 28 DIN 933-8.8
17	035 759 02	1	1	SAE 5
18	501 374 00	4	4	18 x 18 DIN 7346
19	500 031 00	4	4	14 DIN 128
20	501 373 00	4	4	M 14x1,5x50 DIN 960-8.8
21	500 029 00	2	2	10 DIN 128
22	500 296 00	2	2	M 10 x 45 DIN 933-8.8
23	035 791 00	4	—	
24	038 787 00	1	—	
25	500 632 00	4	—	12 DIN 128 A3C
26	502 593 00	4	—	M 12x110 DIN 931-8.8 A3C
27	038 788 00	1	—	
28	500 031 00	2	—	14 DIN 128
29	501 875 00	2	—	M 14x1,5x30 DIN 961-8.8
30	500 029 00	4	—	10 DIN 128
31	500 292 00	4	—	M 10 x 25 DIN 933-8.8
32	035 929 01	—	1	
33	502 376 00	1	1	F 19
34	034 693 00	—	4	
35	036 840 02	1	—	
36	500 530 00	2	—	M 8 x 70 DIN 912-8.8

A 06 Motorfüße
 Engine brackets
 Pieds moteur
 Soportes del mot.

A 12 Riemenschutz
 Belt guard
 Protect. courroie
 Protec. correa

A 15 Anschlußgeh.
 Intern. housing
 Bride raccord
 Caja de con.

Tafel Nr.
 Tabl. No.
 31

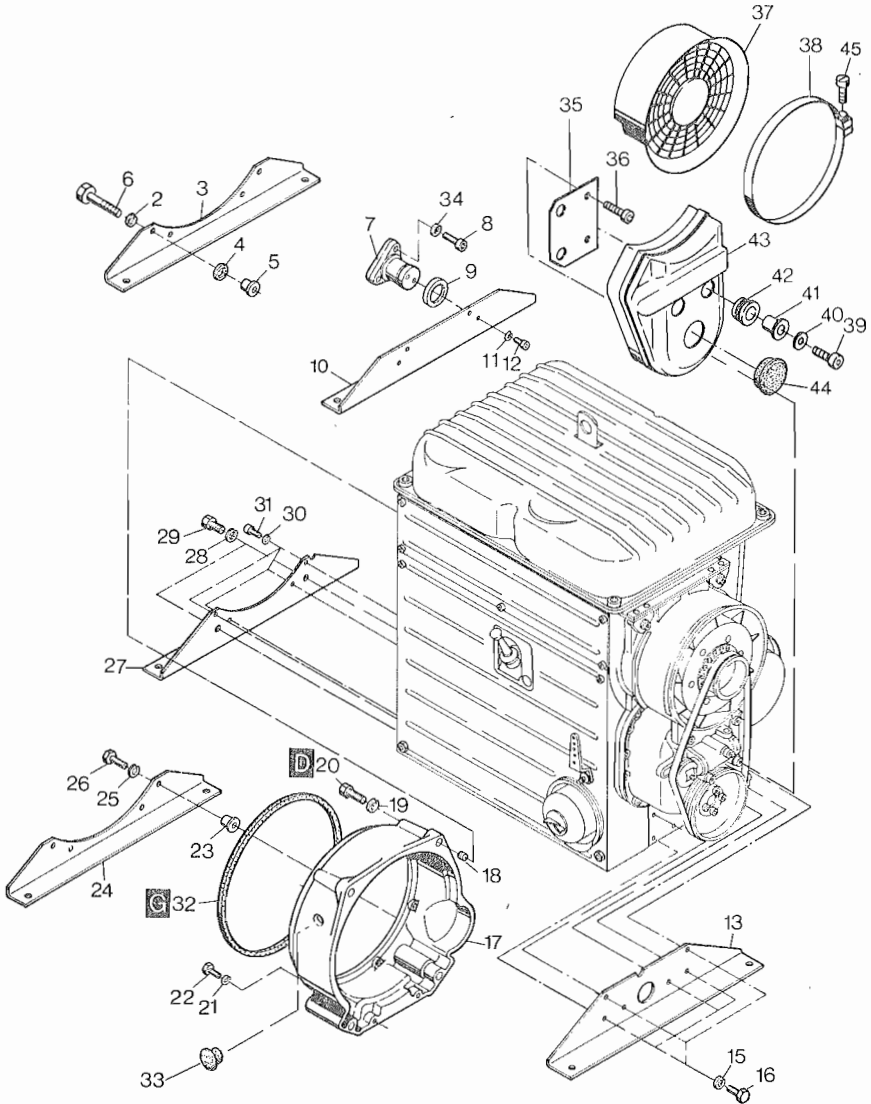

Fig. No.	Bestell-Nr.	Stück	Hinweise	
	Ordering No.	Quantity	Hints	Indications
	No. référence	Quantites	Indicaciones	
	No. de pedido	Cantidades		
		2...4L...S/Z	2...4L...C/K	
37	036 839 00	1	—	
38	038 024 00	1	—	
39	501 706 00	2	—	M 6 x 20 DIN 912-8.8 A3C
40	501 143 00	2	—	6,4 DIN 7349 Zn
41	033 776 00	2	—	
42	036 652 00	2	—	
43	037 110 01	1	—	
44	502 430 00	1	—	F 31
45	502 843 00	1	—	M 4 x 30 DIN 84-4.8 A3C

A 07

Ölkühler, Ölwanne
Oil cooler, oil sump
Radiateur d'huile, carter d'huile
Radiador de aceite, carter de aceite

Tafel Nr.
Tabl. No.

32

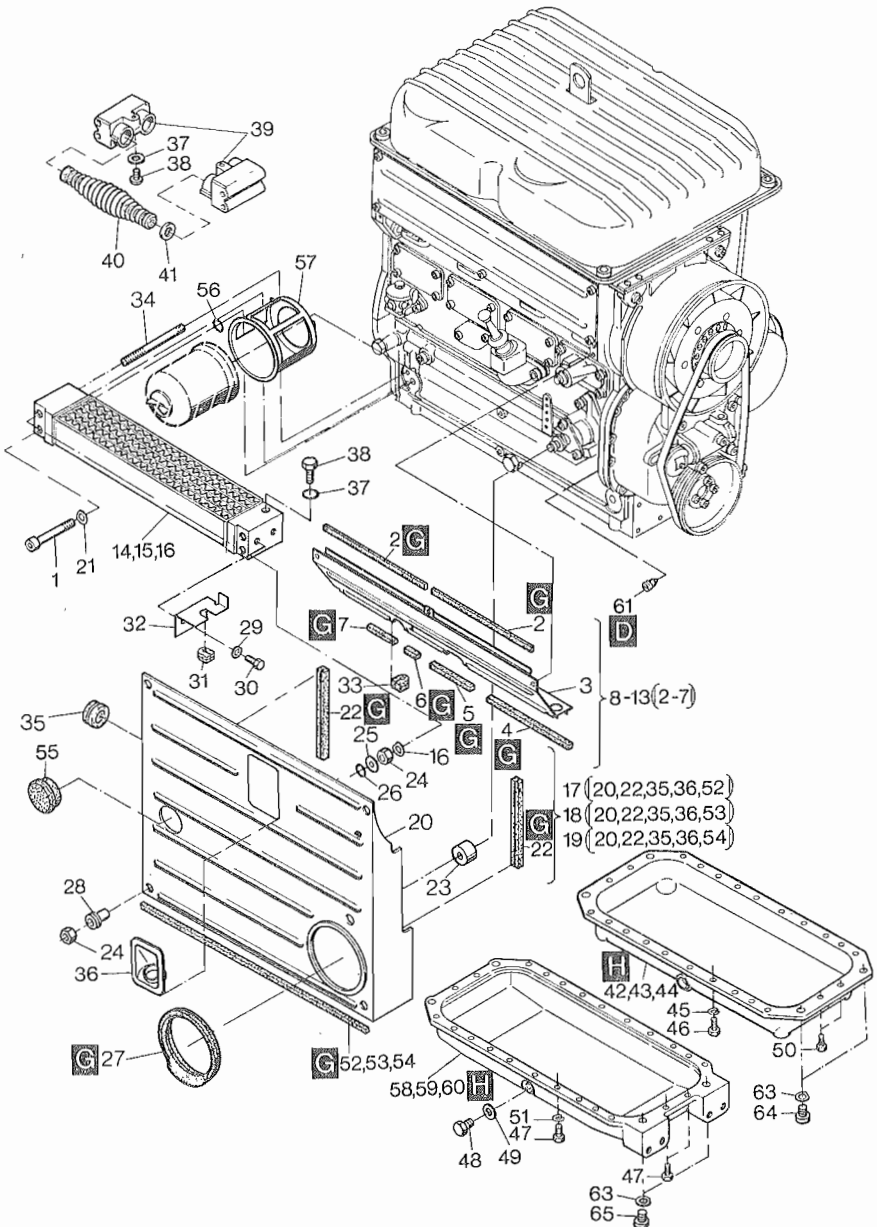

Fig. No.	Bestell-Nr. Ordering No. No. référence No. de pedido	Stück Quantity Quantites Cantidades						Hinweise Hints Indications Indicaciones	
		2 L...S/Z	2 L...C	3 L...S/Z	3 L...C	4 L...S/Z	4 L...C/K		
1	502 041 00	2	4	2	4	2	4	M 8 x 95	DIN 6912-8.8
2	035 640 00	1	—	—	—	—	—	231 mm	
2	035 636 00	—	—	2	—	—	—	173 mm	
2	035 726 00	—	—	—	—	2	—	240 mm	
3	—	—	—	—	—	—	—		
4	035 637 01	—	—	1	—	1	—	214 mm	
5	035 725 01	—	—	—	—	1	—	97 mm	
6	035 644 01	1	—	—	—	—	—	128 mm	
6	035 985 00	—	—	1	—	—	—	32 mm	
6	035 990 00	—	—	—	—	1	—	30 mm	
7	035 987 00	1	—	—	—	—	—	47 mm	
7	035 638 00	—	—	1	—	—	—	67 mm	
8	007 475 11	1	—	—	—	—	—		
9	007 476 11	—	—	1	—	—	—		
10	007 477 11	—	—	—	—	1	—		
11	010 806 00	1	—	—	—	—	—		
12	010 808 00	—	—	1	—	—	—	} f. Taf./Tab.30, Pos.21,22	
13	010 810 00	—	—	—	—	1	—		
14	036 478 01	1	1	—	—	—	—	} 2 L... S 2501-3000 min ⁻¹ 2 L... Z 2301-3000 min ⁻¹	
15	036 479 01	—	—	1	1	—	—		
16	036 480 01	—	—	—	—	1	1	4 L40 C/K ... 2300 min ⁻¹	
16	037 615 01	—	—	—	—	—	1	4 L 40 C/K n>2300 min ⁻¹	
17	007 435 10	1	—	—	—	—	—		
18	007 437 10	—	—	1	—	—	—		
19	007 460 10	—	—	—	—	1	—		
20	—	—	—	—	—	—	—		
21	500 035 00	4	4	4	4	4	4	B 8	DIN 137
22	035 662 00	2	—	2	—	2	—	168 mm	
23	035 794 00	1	—	1	—	1	—		
24	500 229 00	4	—	4	—	4	—	M 8	DIN 934-8
25	035 956 00	2	—	2	—	2	—		
26	035 755 00	2	—	2	—	2	—		
27	035 940 01	1	—	1	—	1	—		
28	009 214 00	2	—	2	—	2	—		
29	500 812 00	—	2	—	2	—	2	A 6	DIN 137
30	500 255 00	—	2	—	2	—	2	M 6 x 12	DIN 933-8.8

A 07

Ölkühler, Ölwanne
Oil cooler, oil sump
Radiateur d'huile, carter d'huile
Radiador de aceite, carter de aceite

Tafel Nr.
Tabl. No.

32

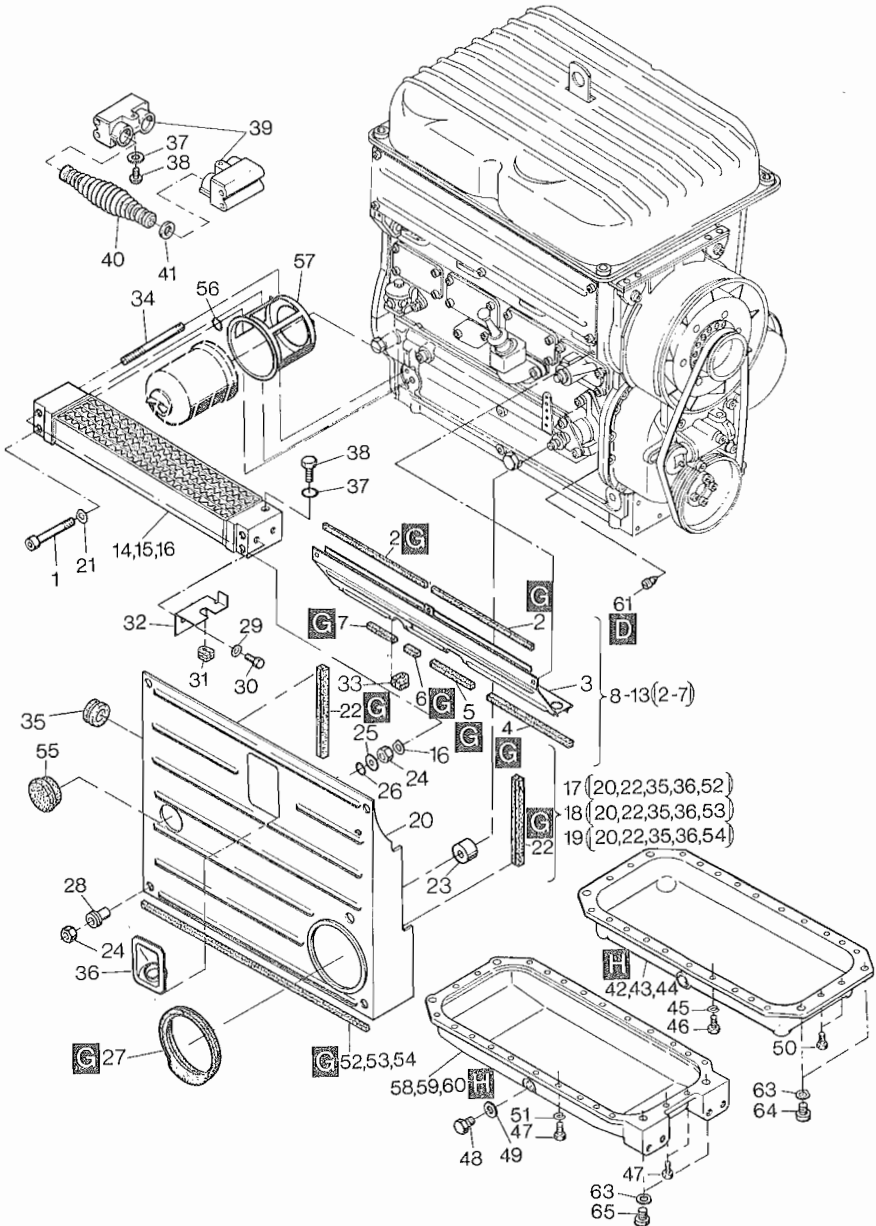

Fig. No.	Bestell-Nr. Ordering No. No. référence No. de pedido	Stück Quantity Quantités Cantidades						Hinweise Hints Indications Indicaciones
		2 L...S/Z	2 L...C	3 L...S/Z	3 L...C	4 L...S/Z	4 L...C/K	
31	035 689 00	—	1	—	1	—	1	
32	036 201 01	—	1	—	1	—	1	
33	035 689 00	1	—	1	—	1	—	
34	035 814 01	2	—	2	—	2	—	
35	501 587 00	1	—	1	—	1	—	
36	037 614 00	1	—	1	—	1	—	
37	500 009 00	1	—	—	—	—	—	A 8 x 11,5 DIN 7603-Cu
38	501 379 00	1	—	—	—	—	—	M 8 x 1 DIN 7604
39	035 553 02	2	—	—	—	—	—	} S ≤ 2500 min ⁻¹ Z ≤ 2300 min ⁻¹
40	035 552 02	2	—	—	—	—	—	
41	400 798 00	4	—	—	—	—	—	
42	009 175 00	1	1	—	—	—	—	
43	009 176 00	—	—	1	1	—	—	
44	009 177 01	—	—	—	—	1	1	
45	500 028 00	8	8	14	14	24	24	8 DIN 128
46	500 267 00	8	8	14	14	24	24	M 8 x 16 DIN 933-8.8
47	500 270 00	12	12	18	18	24	24	8 x 25 DIN 933-8.8
48	501 404 00 W1	1	1	1	1	1	1	M 22x1,5 DIN 7604-5.8
49	500 016 00 W4	1	1	1	1	1	1	A 22 x 27 DIN 7603-Cu
50	502 793 00	4	4	4	4	—	—	M 8 x 16 DIN 933-8.8
51	500 028 00	8	8	14	14	24	24	8 DIN 128
52	037 771 00	1	—	—	—	—	—	203 mm
53	037 772 00	—	—	1	—	—	—	338 mm
54	037 773 00	—	—	—	—	1	—	473 mm
55	037 693 01	1	—	1	—	1	—	
56	501 304 00	2	2	2	2	2	2	
57	009 243 00	1	—	1	—	1	—	
58	036 005 00	1	1	—	—	—	—	
59	036 006 00	—	—	1	1	—	—	
60	036 007 01	—	—	—	—	1	1	
61	034 657 00	1	1	1	1	1	1	
62	—	—	—	—	—	—	—	
63	500 030 00	4	4	4	4	4	4	12 DIN 128
64	500 806 00	4	4	4	4	4	4	M 12x20 DIN 912-8.8
65	500 570 00	4	4	4	4	4	4	M 12x75 DIN 912-12.9

A 18

Steuerdeckel für Hydraulik
Timing cover hydr.
Couvercle p. hydr.
Tapa de mando p. hidr.

Tafel Nr.
Tabl. No.

33

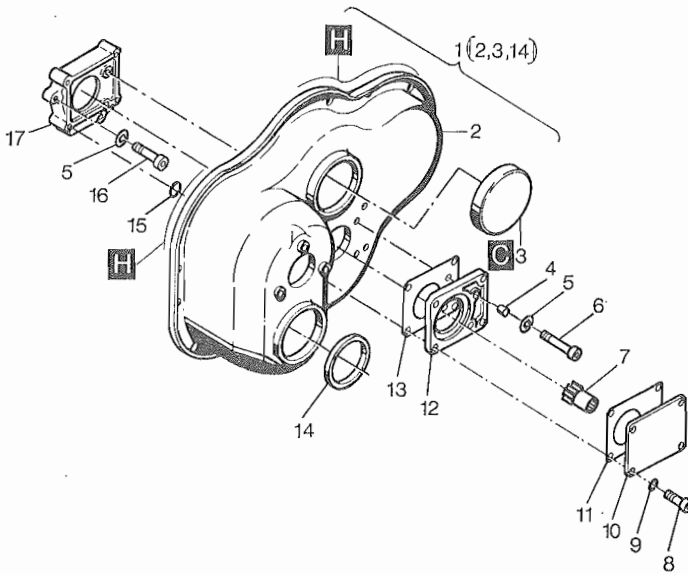

Fig. No.	Bestell-Nr. Ordering No. No. référence No. de pedido	Stück Quantity Quantités Cantidades	Hinweise Hints Indications Indicaciones	
		2...4L...		
1	009 935 00	1		
2	—	—		
3	501 265 00	1		
4	502 620 00	2	10 x 10	DIN 7346
5	501 282 00	4	8	DIN 127
6	502 581 00	2	M 8 x 60	DIN 6912-8.8
7	010 623 00	1		
8	502 688 00	4	M 8 x 30	DIN 912-8.8
9	501 629 00	4	A 8 x 14	DIN 7603-Cu
10	037 616 00	1		
11	035 680 00	1		
12	035 550 11	1		
13	037 544 00	1		
14	501 291 00	1		
15	400 223 00	2	8 x 12 x 2	
16	500 525 00	2	M 8 x 40	DIN 912-8.8
17	037 543 00	1		

Änderungsübersicht
Modification table
Aperçu de modifications
Tabla de modificaciones

Bildtafel Table Planche Tabla	Pos. Nr. Fig. No.	Bestell-Nr. Ordering No. No. référence No. de pedido	Stück Qty. Qté. Cant.	Bildtafel Table Planche Tabla	Pos. Nr. Fig. No.	Bestell-Nr. Ordering No. No. référence No. de pedido	Stück Qty. Qté. Cant.	IMT No.
--	----------------------	---	--------------------------------	--	----------------------	---	--------------------------------	---------

2 L 40.17 / 2 L 31.10				2 L 40.18 / 2 L 31.11				87.468
------------------------------	--	--	--	------------------------------	--	--	--	---------------

08	01	009 297 01	2	08	01	009 297 02	2
08	04	034 695 00	4	08	04	037 752 00	4

3 L 40.16 / 3 L 31.10				3 L 40.17 / 3 L 31.11				87.468
------------------------------	--	--	--	------------------------------	--	--	--	---------------

08	01	009 297 01	3	08	01	009 297 02	3
08	04	034 695 00	6	08	04	037 752 00	6

4 L 40.16 / 4 L 31.10				4 L 40.17 / 4 L 31.11				87.468
------------------------------	--	--	--	------------------------------	--	--	--	---------------

08	01	009 297 01	4	08	01	009 297 02	4
08	04	034 695 00	8	08	04	037 752 00	8