

Original-Ersatzteile

Original-spare parts

Pièces de rechange d'origine

Repuestos originales

Pezzi di ricambio originali

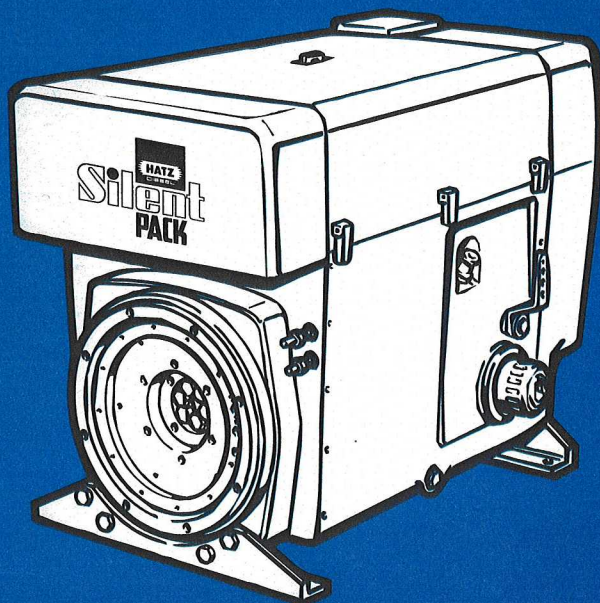

2 L 40 C

3 L 40 C

4 L 40 C

2 L 41 C

3 L 41 C

4 L 41 C

Bestellung für HATZ-Original-Ersatzteile

Order for HATZ Original spare parts

Commande de pièces d'origine HATZ

Pedido de repuestos originales HATZ

Ordine parti di ricambio originali HATZ

1

Besteller / Customer / Client / Cliente / Cliente

2

TYP

MOTOR/FABRIK NO.

MIN-1



3

Ersatzteilliste Nr./ Spare parts list no./ Liste des pièces de rechange no./ Lista de repuestos No./ Lista ricambi n.

2 L 40 . 22

3 L 40 . 22

4 L 40 . 21

2 L 41 . 12

3 L 41 . 12

4 L 41 . 12

4

Stück / Qty / Q.tà	HATZ Ident No.	Stück / Qty / Q.tà	HATZ Ident No.

5

Versandart / Mode of dispatch / Mode d'expédition / Despacho deseado / Modo di spedizione

Post / Surface / Poste / Correo / Posta

Luftfracht / airfreight / frêt aérien / flete aereo / Via aerea

Express / express / exprès / expreso / Espresso

.....

6

Versandadresse / Consignee / Adresse destination / Dirección / Indirizzo di destinazione

Bestellung an: Order at: Commande à: Pedido a:

- die nächste HATZ-Servicestelle (siehe Servicestellenverzeichnis)
- your nearest HATZ service station (see service-list)
- votre station-service HATZ la plus proche (voir liste "Service")
- al servicio HATZ más cercano (ver cuaderno de Servicio)
- al più vicino centro di servizio HATZ (vedi lista centri autorizzati)

**MOTORENFABRIK HATZ
D-94099 RUHSTORF**

Tel: 0 85 31 / 319 - 0

Fax: 0 85 31 / 31 94 21

eMail: Hatz.Werbung@t-online.de

http://www.hatz.com

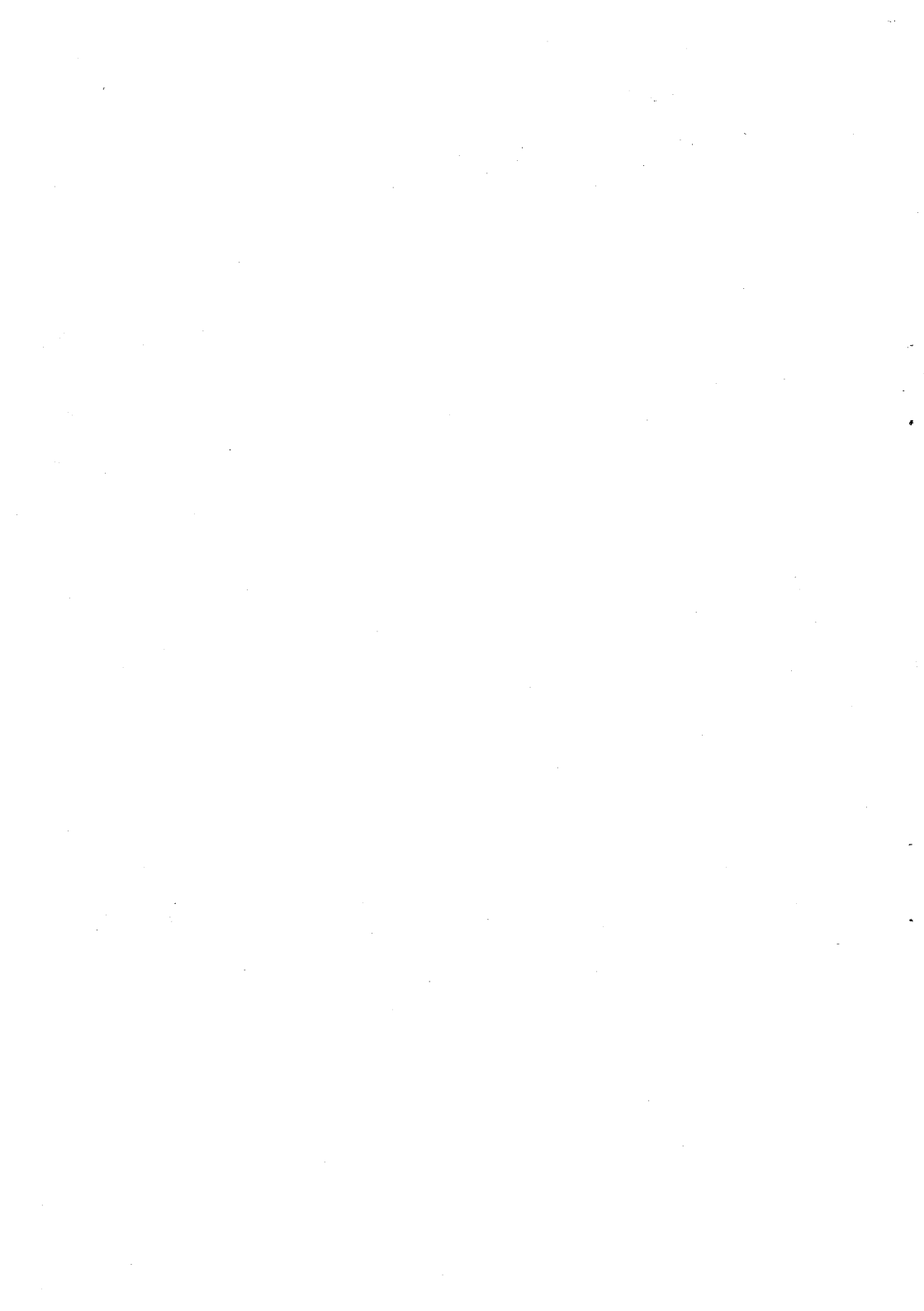

Inhaltsverzeichnis		Index	Tafel-Nr Table N
M ..	Grundmotor	Basic engine	
00	Ersatzteilsätze,	Spare parts kits,	01
34	Zubehör	accessories	02
01	Kurbelgehäuse	Crankcase	03 + 04
01	Massenausgleich	Compensation of masses	05
02, 03	Kurbelwelle	Crankshaft	06
04	Nockenw., Regler, Spritzversteller	Camshaft, governor, timer	07
04	Drehzahlverstellung	Speed control	08
05, 06	Kolben, Pleuel, Zylinder	Piston, conrod, cylinder	09
07	Zylinderkopf	Cylinder head	10
09, 10	Stoßstangen, Ölpumpe	Pushrod, oil pump	11
11	Steuerdeckel	Timing cover	12
12	Startfüllung	Extra fuel device	13
13	Gebälse	Blower	14
14	Einspritzausrüstung	Injection equipment	15
16, 17	Riemenscheibe, Schwungrad	Pulley, flywheel,	
20	Hydr. Abstellvorrichtung	hydr. belt tensioner	16
22, 27	Luftfilter, Luftansaugrohr	Air filter, air intake manifold	17
26	Luftführung	Air ducting	18
26	Luftführung	Air ducting	19
35	Kapsel C	Capsule C	20 + 23
35	Kapsel - Abluftschacht 2 - 3 L..C	Capsule - air ducting 2 - 3 L..C	21
35	Kapsel - Abluftschacht 4 L..C / K	Capsule - air ducting 4 L..C / K	22
A ..	Zusatzausrüstung	Equipements	
01	Kraftstoff	Fuel	24
02	Zyklon	Cyclon	25
03	Auspuff C	Exhaust C	26
05	Starter, Generator	Starter, alternator	27
05, 10	Armaturenkasten	Instrument box	28
05, 10	Armaturen, Leitungen	Electric equipment, wirings	29
06, 15	Motorfüße, Anschlußgehäuse,	Engine brackets, Intermediate housing	30
07	Ölkühler, Ölwanne	Oil cooler, oil sump	31
16	Elastische Kupplung	Flexible coupling	32
18	Steuerdeckel f. Hydraulik	Timing cover hydr.	32
	Serien-Nr.-Änderungen	Serial-code modification list	Seite/Pa 96

Sommaire

Indice

M ..	Moteur de base	Motor de base	
00 34	Jeu de pièces de rechange, accessoires,	Juegos de recambios, accessorios,	01 02
01	Carter moteur	Caja cigueñal	03 + 04
01	Equilibrage des masses	Compensación de las masas	05
02, 03	Vilebrequin	Cigüeñal	06
04	Arbre à cames, regulateur regime, variateur d'avance	Arbol de levas, regulador variador de avance	07
04	Reglage regime	Ajuste de revoluciones	08
05, 06	Piston, bielle, cylindre	Embolo, biela, cilindro	09
07	Culasse	Culata	10
09, 10	Tige de culbuteur, pompe a huile	Varilla de balancín, bomba de aceite	11
11	Couvercle distribution	Tapa de mando	12
12	Sucharge	Sobre aliment.-arranque	13
13	Soufflerie	Ventilador	14
14	Equipement d'injection	Equipo de inyección	15
16, 17	Poulie, volant,	Polea, volante,	
20	tendeur hydr.	tensor hidráulico	16
22, 27	Filtre à air, collecteur d'admission	Filtro de aire, tubo de aspiración	17
26	Carter ventilation	Conducción de aire	18
26	Carter ventilation	Conducción de aire	19
35	Capsule C	Cápsula C	20 + 23
35	Capsule-carter ventilation 2-3 L..C	Capsula-chapa de aire 2-3 L..C	21
35	Capsule-carter ventilation 4 L..C/K	Capsula-chapa de aire 4 L..C/K	22

A .. Accessoires

Equipos

01	Carburant	Combustible	24
02	Cyclone	Ciclon	25
03	Echappement C	Escape C	26
05	Demarreur, alternateur	Arrancador, alternador	27
05, 10	Boitiere de bord	Cuadro de mando	28
05, 10	Equipement électrique, cable	Equipo eléctrico, cables	29
06, 15	Pieds moteur, bride raccord,	Soportes del motor, caja de conexión	30
07	Radiateur d'huile, carter d'huile	Radiador de aceite, carter de aceite	31
16	Accouplement elastic	Acoplamiento elast.	32
18	Couvercle pompe hydraulic	Tapa de mando p. hidraulico	32

Indice		Tavola N.
M ..	Motore di base	
00	Serie guarnizioni	01
34	kit accessori	02
01	Basamento motore	03 + 04
01	Masse controrotanti	05
02, 03	Albero a gomito,	06
04	Albero a camme, regolatore di giri variante di anticipo	07
04	Comando acceleratore	08
05, 06	Pistone, biella, cilindro	09
07	Testa	10
09, 10	Asta bilancieri, pompa olio	11
11	Coperchio distribuzione	12
12	Supplemento	13
13	Ventilatore	14
14	Equipaggiamento di iniezione	15
16,17	Puleggia, volano	
20	tendicinghia idraulico	16
22, 27	Filtro aria, collettore aspirazione	17
26	Carter ventilatore	18
26	Carter ventilatore	19
35	Cofanatura C	20 + 23
35	Cofanatura silenziata 2 - 3 L..C	21
35	Cofanatura silenziata 4 L ..C / K	22
A ..	Accessori	
01	Serbatoio e circuito combustibile	24
02	Prefiltro a ciclone	25
03	Scarico C	26
05	Motorino avviamento, alternatore	27
05, 10	Cruscotto	28
05, 10	Equipaggiam. elettrico, cablaggio	29
06, 15	Staffe supporto motore, Flangia accoppiamento	30
07	Radiatore olio, coppa olio	31
16	Giunto elastico	32
18	Coperchio per pompa idraulica	32
		Pagina
	Modifica dei codici	96

M 00

Ersatzteilsätze
Spare part kits
Jeux de pièces de rechange
Juegos de piezas de recambios
Serie guarnizioni

Tafel Nr.
Tabl. No.
Tavola N.

01

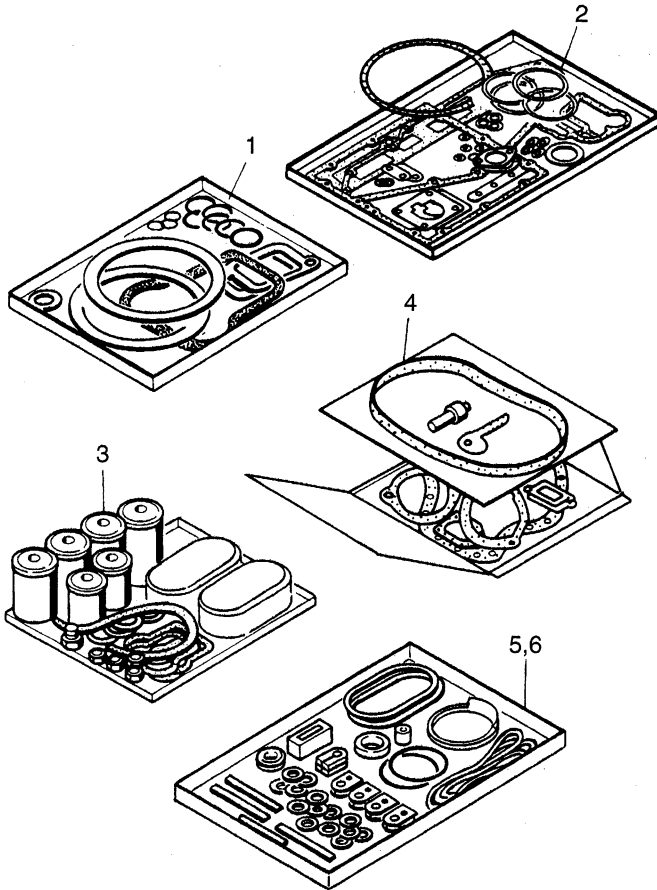

Fig.- No.	HATZ Ident-No.	Stück Qty.			P / W d / D	Bemerkungen Notes
2L..C 3L..C 4L..C/K						
<p>W: Im Wartungssatz enthalten. Incl. in maintenance kit. Contenu dans le jeu d'entretien. Incluido en el juego de mantenimiento. Contenuto nella serie manutenzione</p>						
<p>d: Im Dichtungssatz für 1 Zyl.-Kopf enthalten. Incl. in gasket set for 1 cylinder head. Contenu dans le jeu de joint p. 1 culasse. Incluido en el juego de juntas p. 1 culata. Contenuto nella serie guarnizioni p. 1 testa.</p>						
<p>P: Im Pannensatz enthalten. Incl. in emergency kit. Contenu dans le jeu secur. Incluido en el juego para averias. Contenuto nella serie di prima necessità.</p>						
<p>D: Im Dichtungssatz Kurbelgehäuse Incl. in gasket set crankcase. Contenu dans le jeu de joints carter moteur. Incluido en el juego de juntas caja cigueñal. Contenuto nella serie guarnizioni basamento.</p>						
<p>1: Anzahl pro Satz - Qty. per kit Quantite par jeu Cantidad por juego Quantità per serie</p>						
1	00992202	2	3	4	P 1	Dichtungssatz für 1 Zylinderkopf Gasket set for 1 cyl. head Jeu de joint p. 1 culasse Juego de juntas para 1 culata Serie guarnizioni per 1 testa.
2	01230902	1	1	1		Dichtungssatz für Kurbelgehäuse Gasket set for crankcase Jeu de joints p. carter moteur Juego de juntas para caja cigueñal Serie guarnizioni basamento.
3	00987104	1	-	-		Wartungssatz für 1000 h
3	00991504	-	1	-		1000 hours maintenance kit
3	01203304	-	-	1		Kit d'entretien 1000 heures - Juego de piezas para servicio 1000 horas Kit di manutenzione a 1000 ore.
4	01205701	1	-	-	2L40C	Pannensatz - Emergency kit
4	01544100	1	-	-	2L41C	Kit de secours - Juego para averias
4	00987202	-	1	1	3-4L40...	Kit di prima necessità
4	01544300	-	1	1	3-4L41...	
5	-----	-	-	-		Gummitellesatz, Rubber comp. set, Garniture caout., „C / K“ - Guarnicion goma Guarnizioni in gomma
6	01215700	1	1	1		

Fig.- No.	HATZ Ident-No.	Stück Qty.			P / W d / D	Bemerkungen Notes
		2L..C	3L..C	4L..C/K		
1	00938301	1	1	1		Zubehörsatz - Accessoires kit Sort. accessoires Juego de accesorios Serie accessori
2	03638900	2	2	2		„C“
3	03614401	2	2	2		„C“
4	03788301	1	1	1		
5	03325400	1	1	1		
6	03175200	1	1	1		12 V „C / K“
7	03669400	1	1	1		24 V „C / K“
8	03430612	1	1	1		

Dicht- und Klebstoffe
Sealing- and bonding adhesives
Etanchéifiant et Colle

Materias para empaquetar y pegar
Adesivi e collanti

A = 502 230 01	Loctite Activator N	500 ml	} siehe Hinweis auf den einzelnen Bildtafeln as specified in the individual tables suivant les remarques sur les tableau correspondant según las indicaciones de las tablas correspondientes seguire le indicazioni sul quadro corrispondente
B = 502 231 00	Loctite 573	50 ml	
C = 502 232 00	Loctite 601	50 ml	
D = 502 233 00	Loctite 221	50 ml	
E = 502 234 00	Loctite 648	10 ml	
F = 502 238 00	Technicoll 8058	0,75 kg	
+ 502 239 00	Technicoll 8367	0,75 kg	
G = 502 565 01	Loctite IS 407	20 g	
H = 502 825 01	Silicon	30 ml	
J = 502 830 03	Hochtemp. Paste	100 ml	

M 01

Kurbelgehäuse
Crankcase
Carter moteur
Caja cigueñal
Basamento motore

Tafel Nr.
Tabl. No.
Tavola N.

03

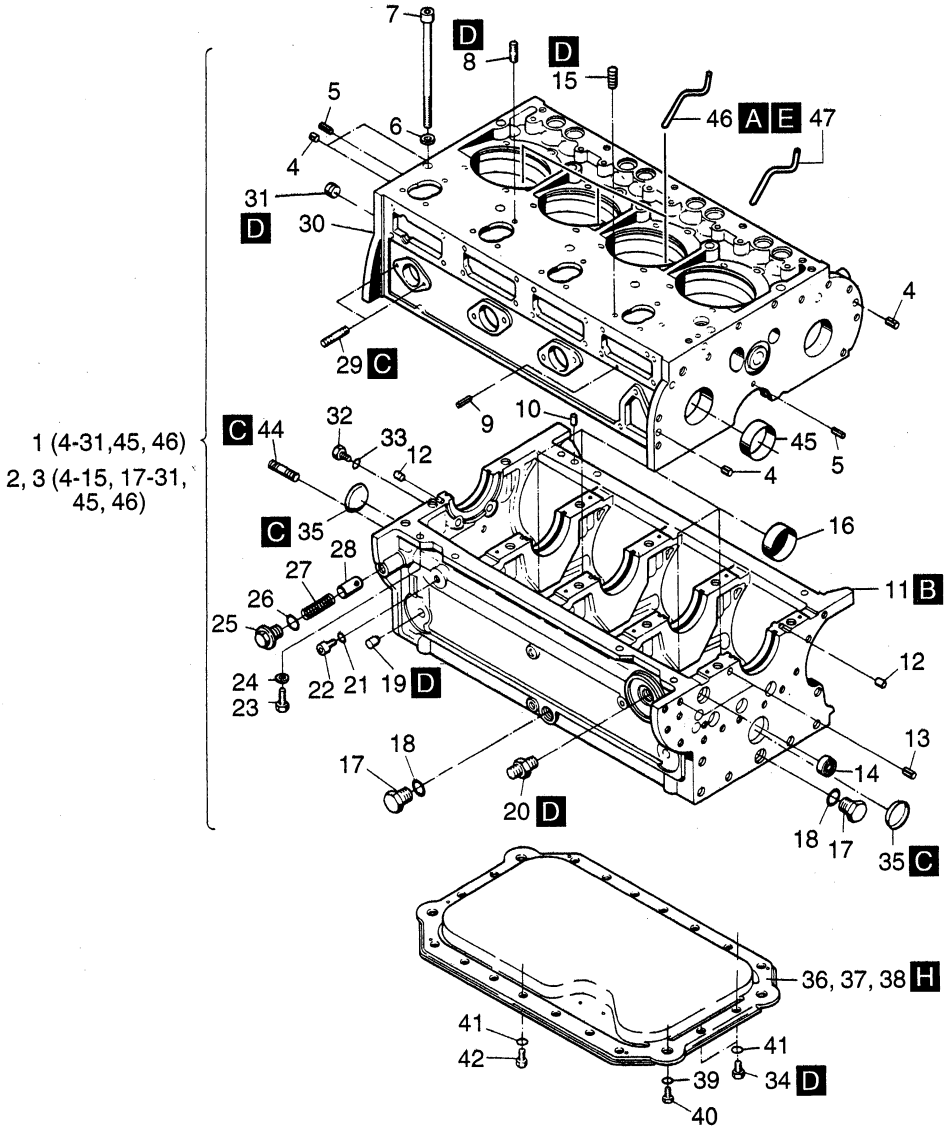

Fig.- No.	HATZ Ident-No.	Stück Qty.		P / W d / D	Bemerkungen Notes
		2L..C	3L..C	4L..C/K	
1	01200901	-	-	1	„K“
2	00991802	-	1	-	
3	00975702	1	-	-	
3	01202101	-	-	1	
4	50140000	4	4	4	8 x 8 DIN 7346
5	50130500	2	2	2	5 x 24 DIN 1481
6	03469300	6	8	10	
7	50125900	6	8	10	M 12 x 1,5 x 190 DIN 912-10.9
8	50290800	5	8	11	M 8 x 20 DIN 939-10.9
9	50130500	1	1	1	5 x 24 DIN 1481
10	03635300	1	1	1	8 x 20
11	-----	-	-	-	
12	50131400	2	2	2	10 m 6 x 14 DIN 7-St 50K
13	50084901	2	2	2	8 x 12 DIN 7346
14	50130200	1	1	1	HK 16/16
15	03863600	1	1	1	
16	03627100	-	-	4	„K“ 48
17	50140400	2	2	2	W1 M 22 x 1,5 DIN 7604-5.8
18	50001600	2	2	2	W4, D4 A 22 x 27 DIN 7603-Cu
19	03645700	2	2	2	n ≤ 1500 min ⁻¹
20	40065400	1	1	1	
21	50062400	1	1	1	D3 A 10 x 13,5 DIN 7603-Cu
22	50062300	1	1	1	M 10 x 1 DIN 908
23	50026800	8	12	17	8 x 20 DIN 933-8.8
24	50002800	8	12	17	8 DIN 128
25	03249300	1	1	1	M 18 x 1,5
26	50001400	1	1	1	W4, D2 A 18 x 22 DIN 7603-Cu
27	03639900	1	1	1	
28	03639800	1	1	1	
29	50139200	2	2	2	M 6 x 16 DIN 939-8.8
30	-----	-	-	-	
31	50043800	1	1	1	M 14 x 1,5 DIN 906
32	-----	-	-	-	
33	-----	-	-	-	
34	50279300	4	4	-	M 8 x 16 DIN 933-8.8
35	50140800	2	2	-	38 DIN 443

M 01

Kurbelgehäuse
Crankcase
Carter moteur
Caja cigueñal
Basamento motore

Tafel Nr.
Tabl. No.
Tavola N.

03

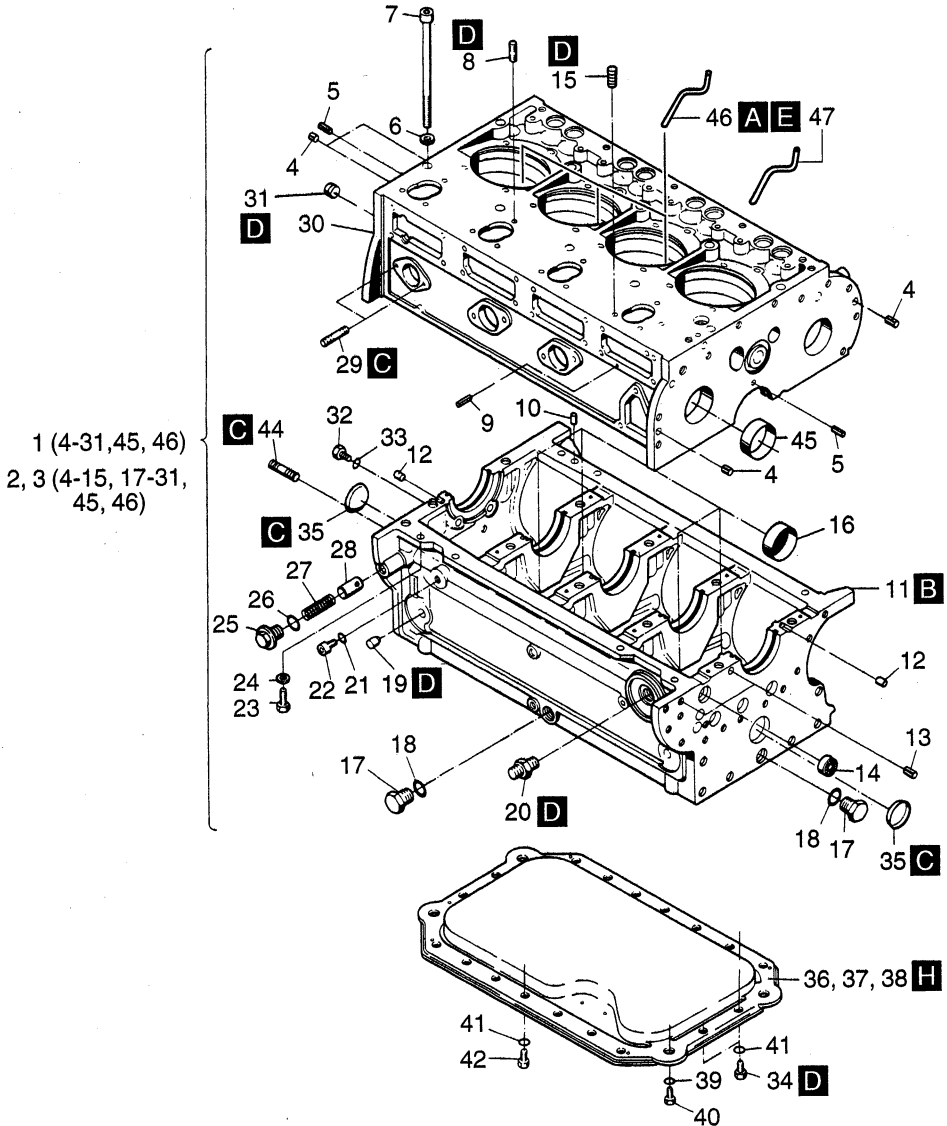

Fig.- No.	HATZ Ident-No.	Stück Qty.			P / W d / D	Bemerkungen Notes
		2L..C	3L..C	4L..C/K		
36	03752601	1	-	-		
37	03752701	-	1	-		
38	-----	-	-	-		s. Taf., Tabl. 31, Pos. 17
39	50003000	4	4	-	12	DIN 128
40	50080600	4	4	-	M 12 x 20	DIN 912-8.8
41	50002800	12	18	-	8	DIN 128
42	50026700	8	14	-	M 8 x 16	DIN 933-8.8
43	-----	-	-	-		
44	50240800	2	2	-	M 8 x 12	DIN 938-8.8
45	03765500	1	1	1		
46	03645900	1	2	3		s. Techn. Hinweis 950 386 01
47	03646000	1	1	1		s. drawing 950 386 01

M 01

Kurbelgehäuse
Crankcase
Carter moteur
Caja cigueñal
Basamento motore

Tafel Nr.
Tabl. No.
Tavola N.

04

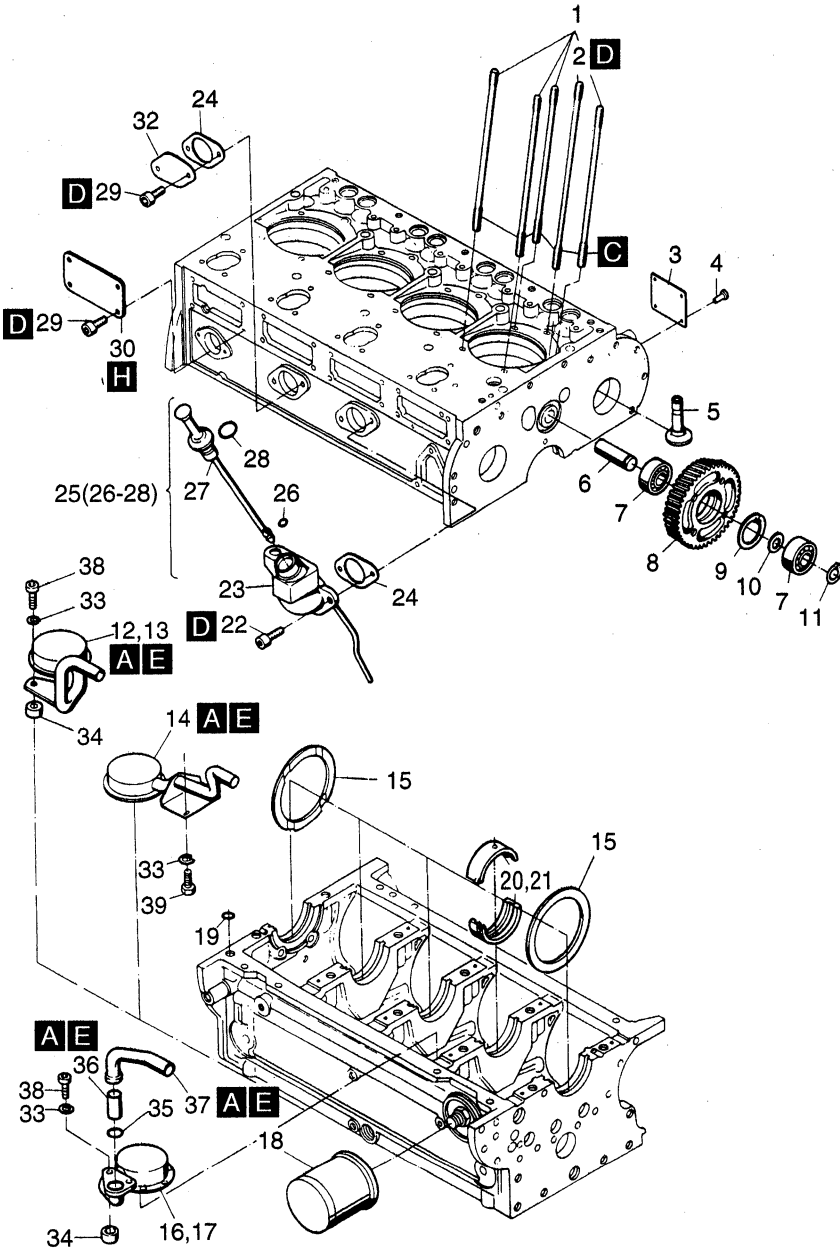

Fig.- No.	HATZ Ident-No.	Stück Qty.	P / W d / D	Bemerkungen Notes			
		2 L..C	3 L..C	4 L..C/K			
1	03625702	8	12	16			
2	03625802	2	3	4			
3	03225504	1	1	1			
4	40002500	4	4	4			
5	03554501	4	6	8			
6	03469601	1	1	1			
7	50013700	2	2	2	6204 C3	DIN 625	
8	03561702	1	1	1			
9	50021700	1	1	1	47 x 1,75	DIN 472	
10	03462300	1	1	1			
11	50127600	1	1	1	20 x 1,75	DIN 471	
12	00929301	1	-	-			
13	00929401	-	1	-			
14	00929201	-	-	1	f. Taf. / Tabl. 31,	Pos. 17	
15	03463300	2	2	2			
16	00929001	1	-	-	} f. Taf. / Tabl. 31,	Pos. 15, 16	
17	00929101	-	1	-			
18	40065300	1	1	1	W2		
19	50219400	1	1	1	D1	12 x 2	
20	03555500	3	4	5		72 mm Ø	
21	03551600	3	4	5		71,5 mm Ø	
22	50051900	2	2	2		M 8 x 20	DIN 912-8.8
23	00932602	1	-	-			
23	00914803	-	1	1			
24	50129000	1	1	2	D2	36	
25	00739702	1	1	-		„A“	
25	00931100	1	-	-		„C“	} f. Taf. / Tabl. 31, Pos. 15, 16, 17
25	00930800	-	1	1		„D“	
26	50202502	1	1	1	D1	3,0 x 1,6	
27	-----	-	-	-			
28	50139900	1	1	1	D1	23,3 x 2,4	
29	50128900	4	8	14		M 8 x 16	DIN 912-8.8
30	03469200	1	2	3			
31	-----	-	-	-			
32	03263300	-	-	1			
33	50002800	2	2	2		8	DIN 128

M 01

Kurbelgehäuse
Crankcase
Carter moteur
Caja cigueñal
Basamento motore

Tafel Nr.
Tabl. No.
Tavola N.

04

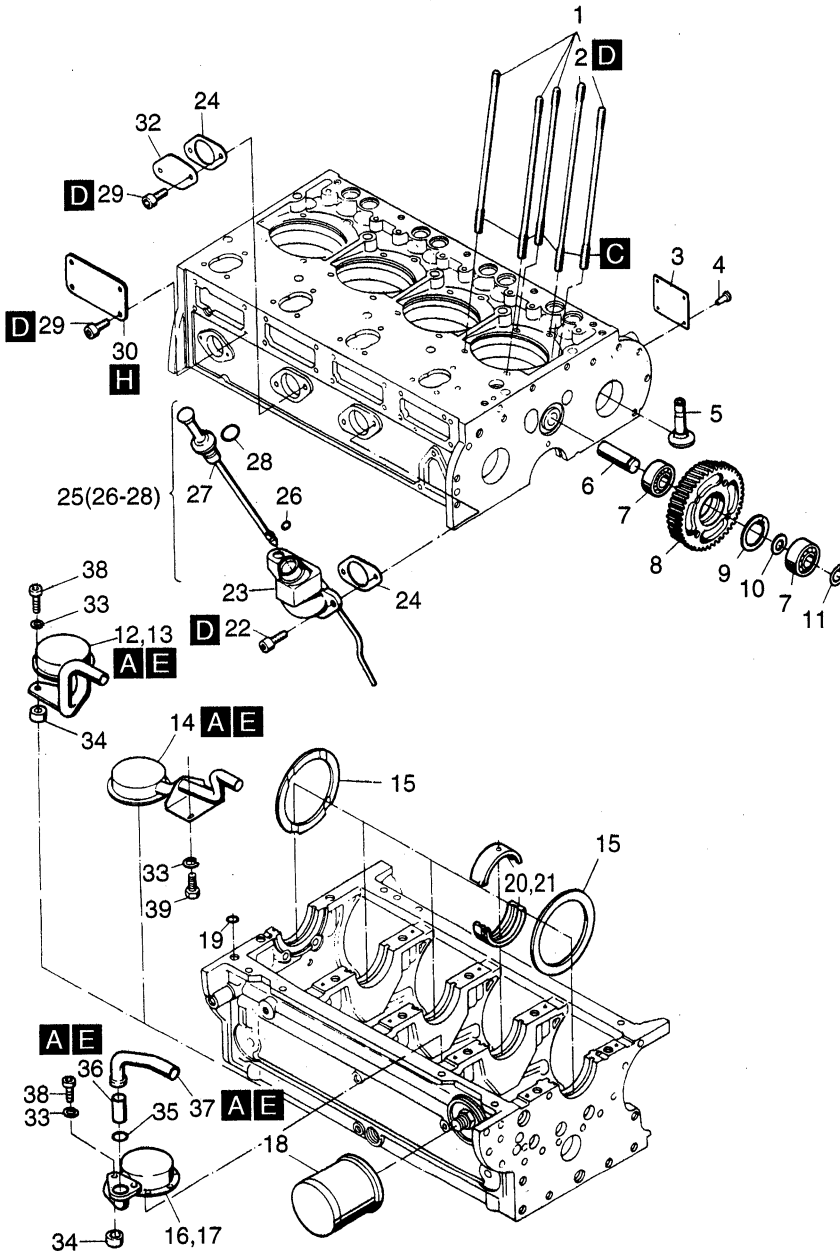

Fig.- No.	HATZ Ident-No.	Stück Qty.			P / W d / D	Bemerkungen Notes
		2 L..C	3 L..C	4 L..C/K		
34	03467000	2	2	-		
35	50258000	1	1	-		17 x 3
36	03617600	1	1	-		f. Taf. / Tabl. 31, Pos. 15, 16
37	03616500	1	1	-		
38	50051900	2	2	-		M 8 x 20 DIN 912-8.8
39	50026700	-	-	2		M 8 x 16 DIN 933-8.8

M 01

Massenausgleich
Compensation of masses
Equilibrage des masses
Compensación de las masas
Masse controrotanti

Tafel Nr.
Tabl. No.
Tavola N.

05

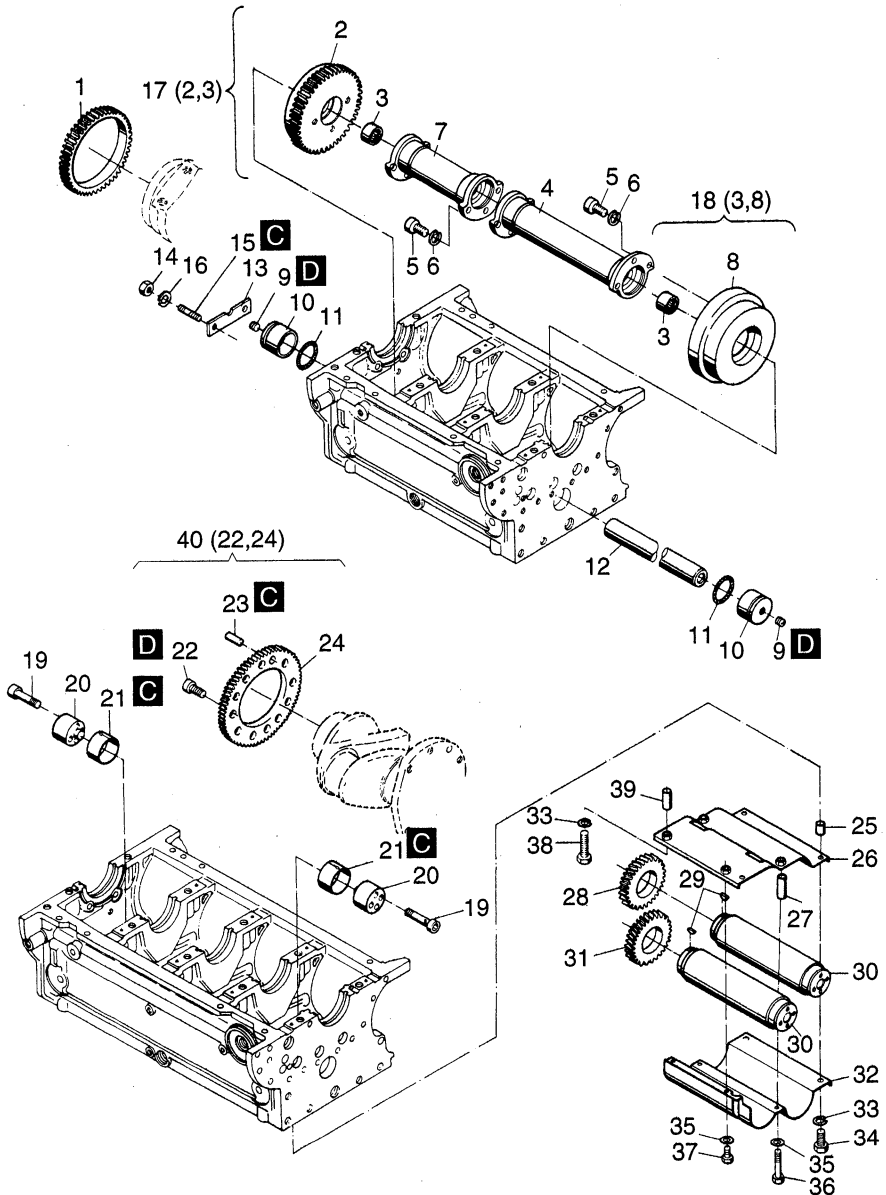

Fig.- No.	HATZ Ident-No.	Stück Qty.			P / W d / D	Bemerkungen Notes
		2L..C	3L..C	4L..C/K		
1	03553300	1	1	-		
2	-----	-	-	-		
3	50128500	2	2	-		
4	04136700	1	1	-		
5	50052000	6	9	-	M 8 x 20	DIN 6912-8.8
6	50002800	6	9	-	8	DIN 128
7	04136600	-	1	-		
8	-----	-	-	-		
9	50043600	2	2	-	M 10 x 1	DIN 906
10	03463400	2	2	-		
11	50132200	2	2	-	33,3 x 2,4	
12	03590000	-	1	-		
12	03463500	1	-	-		
13	03462900	1	1	-		
14	50022900	2	2	-	M 8	DIN 934-8
15	50240800	2	2	-	M 8 x 12	DIN 938-8.8
16	50002800	2	2	-	8	DIN 128
17	00902000	1	1	-		
18	00901900	1	1	-		
19	50127900	-	-	16	M 8 x 40	DIN 912-10.9
20	03627000	-	-	4		
21	03627201	-	-	4		
22	50418800	-	-	8	M 10 x 20	DIN 912-12.9
23	50115000	-	-	1	10 m 6 x 20	DIN 7-St.
24	-----	-	-	-		
25	03599600	-	-	2		
26	00917800	-	-	1		
27	03599800	-	-	2		
28	03553403	-	-	1		
29	50017700	-	-	2	4 x 5	DIN 6888
30	00935600	-	-	2		
31	03553603	-	-	1		
32	03599200	-	-	1		
33	50002800	-	-	4	8	DIN 128
34	50051900	-	-	2	M 8 x 20	DIN 912-8.8
35	50081200	-	-	4	A 6	DIN 137
36	50073700	-	-	2	M 6 x 45	DIN 931-8.8
37	50050600	-	-	2	M 6 x 12	DIN 931-8.8
38	50052100	-	-	2	M 8 x 25	DIN 912-8.8
39	03599700	-	-	2		
40	01508200	-	-	1		

M 02

Kurbelwelle
Crankshaft
Vilebrequin
Cigüeñal
Albero a gomito

Tafel Nr.
Tabl. No.
Tavola N.

06

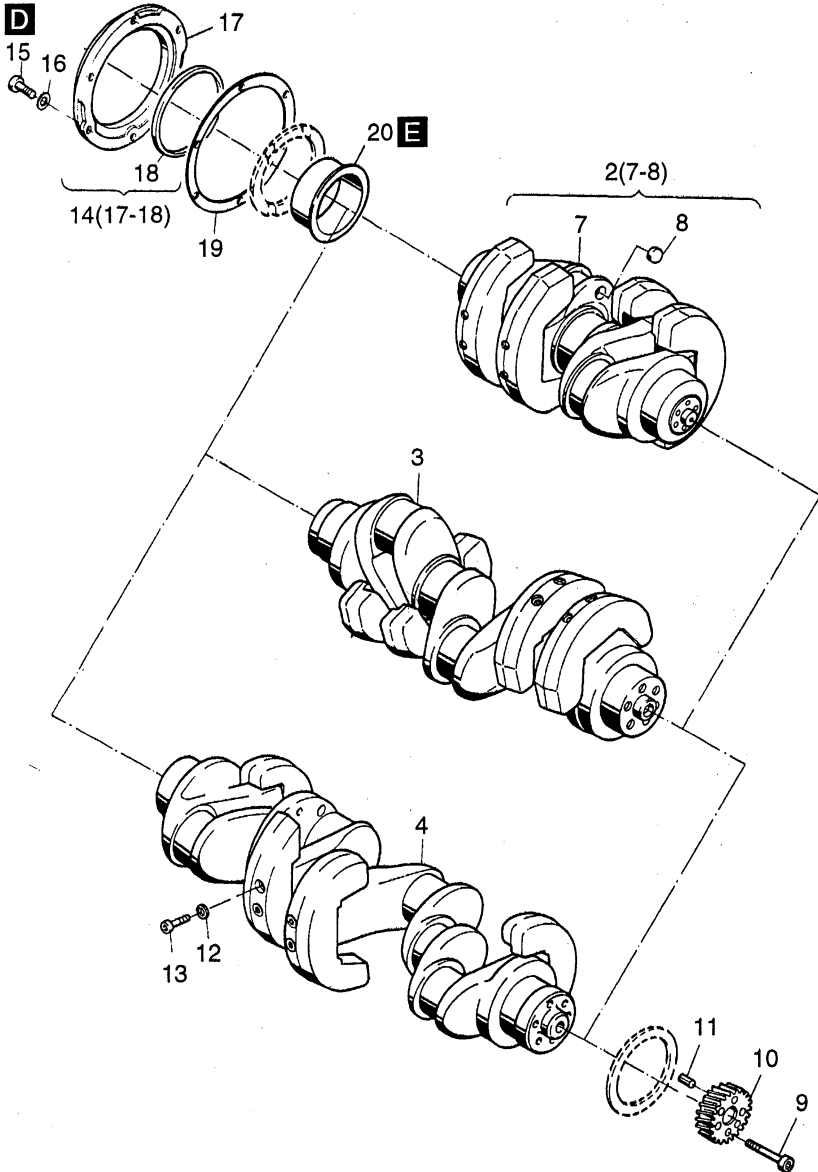

Fig.- No.	HATZ Ident-No.	Stück Qty.	P / W d / D	Bemerkungen Notes	
		2 L..C	3 L..C	4 L..C/K	
1	-----	-	-	-	
2	00950801	1	-	-	
3	00955000	-	1	-	
4	00956300	-	-	1	
5	-----	-	-	-	
6	-----	-	-	-	
7	-----	-	-	-	
8	50207200	2	-	-	2 L 4., 36 DIN 443
9	50127900	6	6	6	M 8 x 40 DIN 912-10.9
10	03561601	1	1	1	
11	50128000	1	1	1	11 x 10 DIN 7346 55SI7
12	50002900	8	8	8	10 DIN 128
13	50132800	8	8	8	M 10 x 40 DIN 912-10.9
14	00957500	1	1	1	
15	50236600	6	6	6	M 6 x 25 DIN 912-8.8
16	50081200	6	6	6	A 6 DIN 137
17	-----	-	-	-	
18	50224601	1	1	1	D1 80 x 100 x 10
19	03550601	1	1	1	D1
20	03780600	0...1	0...1	0...1	

Nockenwelle, Regler, Spritzversteller

Camshaft, governor, timer

M 04

Arbre à cames, regulateur regime, variateur d'avance

Arbol de levas, regulador, variador de avance

Albero a camme, regolatore di giri, variatore di anticipo

Tafel Nr.

Tabl. No.

Tavola N.

07

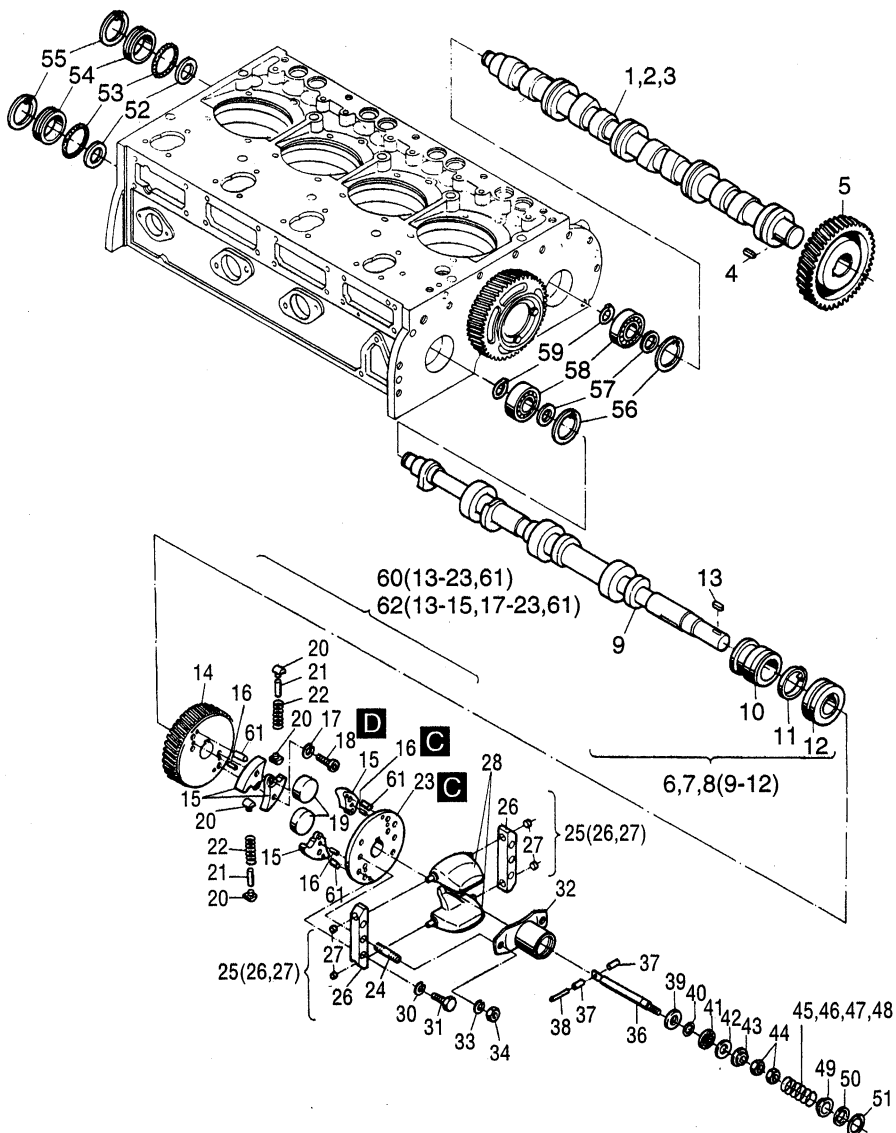

Fig.- No.	HATZ Ident-No.	Stück Qty.			P / W d / D	Bemerkungen Notes
		2 L..C	3 L..C	4 L..C/K		
1	03556700	1	-	-		2L40C, 2L41C
1	03779400	1	-	-		2L40CH, (H)
2	03555700	-	1	-		3L40C, 3L41C
2	03779500	-	1	-		3L40CH, (H)
3	03558000	-	-	1		4L40C, 4L41C
3	03779600	-	-	1		4L40CH / KH (H)
4	50011300	1	1	1		A 8 x 7 x 22 DIN 6885
5	03561800	1	1	1		
6	01212000	1	-	-		2L40
6	01544400	1	-	-		2L41
7	01212100	-	1	-		3L40
7	01544500	-	1	-		3L41
8	01212200	-	-	1		4L40
8	01544600	-	-	1		4L41
9	-----	-	-	-		
10	-----	-	-	-		
11	03576501	1	1	1		
12	-----	-	-	-		
13	50131600	1	1	1		A 6 x 6 x 20 DIN 6885 ST6
14	03561910	1	1	1		
14	04109700	1	1	1		L41
15	03462701	4	4	4		
15	04109400	4	4	4		L41
16	50057900	4	4	4		4 m 6 x 8 DIN 7-9S 20K
17	50140101	8	8	8		6 VHZ (L31 - L40)
18	50143200	8	8	8		M 6 x 18 DIN 6912-10.9
19	03460100	2	2	2		
19	01321900	2	2	2		L41
20	03464500	4	4	4		
20	04109600	4	4	4		L41
21	03561300	2	2	2		
21	04109500	2	2	2		L41
22	03561400	2	2	2		
22	04109800	2	2	2		L41
23	03554710	1	1	1		
23	04109300	1	1	1		L41
24	50131500	2	2	2		M 8 x 30 DIN 938-8.8
25	00745800	2	2	2		L40

Nockenwelle, Regler, Spritzversteller
Camshaft, governor, timer

Tafel Nr.
Tabl. No.
Tavola N.

M 04

Arbre à cames, regulateur regime, variateur d'avance
Arbol de levas, regulador, variador de avance
Albero a camme, regolatore di giri, variatore di anticipo

07

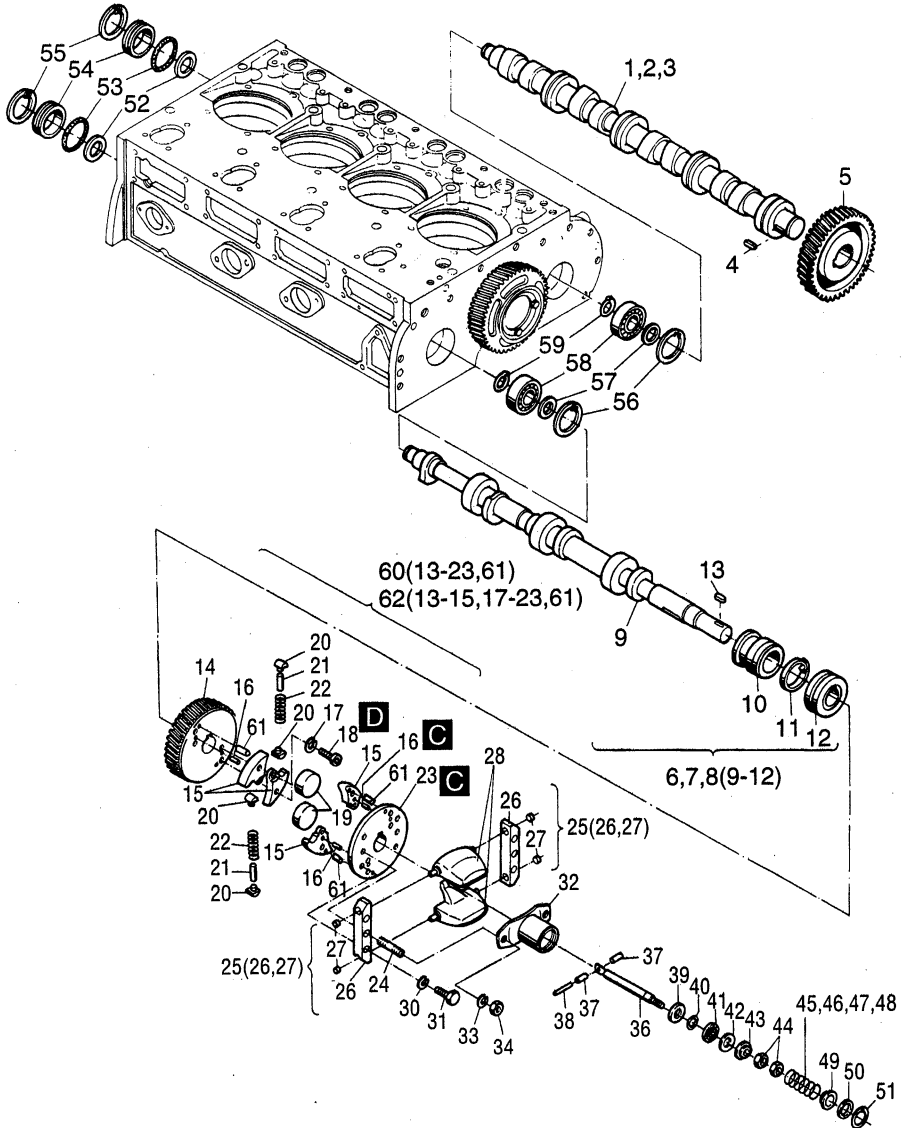

Fig.- No.	HATZ Ident-No.	Stück Qty.	P / W d / D	Bemerkungen Notes	
		2 L.. C	3 L.. C	4 L.. C/K	
26	04112400	2	2	2	L41
27	03572100	4	4	4	L40
28	03572900	2	2	2	
30	50347301	4	4	4	VHZ 8 A3C
31	50027000	4	4	4	M 8 x 25 DIN 938-8.8
32	03773101	1	1	1	
33	40027800	2	2	2	8
34	50022900	2	2	2	M 8 DIN 934-8
35	-----	-	-	-	
36	03772600	1	1	1	
37	03772500	2	2	2	
38	03576400	1	1	1	
39	03772701	1	1	1	
40	50268000	1	1	1	6 x 12 x 0,5 DIN 988
41	50268100	1	1	1	AXK 1024
41	04117900	1	1	1	L41
42	50268200	1	1	1	AS 1024
43	03772800	1	1	1	
44	50144400	2	2	2	M 6 DIN 934-8 A3C
45	03601401	0...1	0...1	0...1	2,5 mm Ø 1500 min ⁻¹ Gen
46	03601301	0...1	0...1	0...1	2,6 mm Ø 1800 min ⁻¹ Gen
47	03601201	0...1	0...1	0...1	3,0 mm Ø ≤ 2300 min ⁻¹
48	03574401	0...1	0...1	0...1	3,2 mm Ø > 2300 min ⁻¹ 3000 min ⁻¹ Gen
49	03571900	1	1	1	
50	03772900	1	1	1	
51	50021000	1	1	1	J 32 x 1,2 DIN 472
52	50132700	0...4	0...4	0...4	37 x 47 x 0,1 DIN 988
52	50277300	0...1	0...1	0...1	37 x 47 x 0,5 DIN 988
53	50130700	2	2	2	D2 42 x 2,5
54	03469700	2	2	2	
55	50021700	2	2	2	47 x 1,75 DIN 472
56	50021700	2	2	2	47 x 1,75 DIN 472
57	50132900	0...3	0...3	0...3	20 x 28 x 0,1 DIN 988
58	50013700	2	2	2	C3 DIN 625
59	50127600	2	2	2	AS 20 x 1,75 DIN 471
60	00919401	1	1	1	L40
61	04092300	4	4	4	6 x 6,52 x 9 L31 - L40
61	50140000	8	8	8	8 x 8 DIN 7346 L41
62	01323800	1	1	1	L 41

M 04

Drehzahlverstellung
Speed control
Reglage regime
Ajuste de revoluciones
Comando acceleratore

Tafel Nr.
Tabl. No.
Tavola N.

08

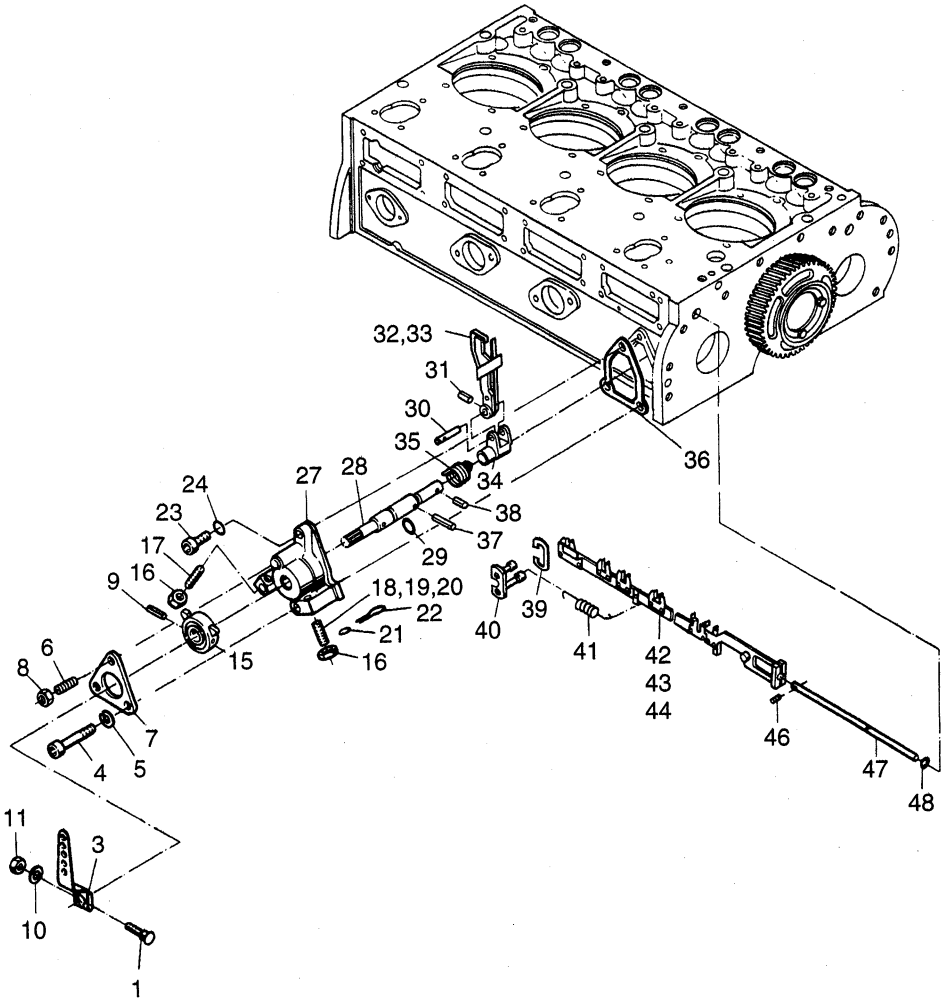

Fig.- No.	HATZ Ident-No.	Stück Qty.			P / W d / D	Bemerkungen Notes
		2L..C	3L..C	4L..C/K		
1	03927300	1	1	1		M 6 x 32
2	-----	-	-	-		
3	03888300	1	1	1		
4	50053000	2	2	2		M 8 x 70 DIN 912-8.8
5	50002800	2	2	2		8 DIN 128
6	50279200	1	1	1		M 8 x 40 DIN 835-8.8 A3C
7	03465800	1	1	1		
8	40028400	1	1	1		V M 8
9	50035000	1	1	1		5 x 40 DIN 1481
10	50144500	1	1	1		6,4 DIN 125 A3C
11	50144400	1	1	1		M 6 DIN 934-8 A3C
12	-----	-	-	-		
13	-----	-	-	-		
14	-----	-	-	-		
15	03468810	1	1	1		
16	50022900	2	2	2		M 8 DIN 934-8
17	03245900	1	1	1		AM 8 x 35
18	03245900	0...1	0...1	0...1		AM 8 x 35 n > 2600 min ⁻¹
19	03642900	0...1	0...1	0...1		AM 8 x 45 n=2200...2600 min ⁻¹
19	03774000	0...1	0...1	0...1		AM 8 x 40 n=2200...2600 min ⁻¹
20	03169501	0...1	0...1	0...1		AM 8 x 50 n < 2200 min ⁻¹
21	40021400	1	1	1		
22	40021500	1	1	1		
23	50051900	1	1	1		M 8 x 20 DIN 912-8.8
24	50162900	1	1	1	D6	A 8 x 14 DIN 7603-Cu
25	-----	-	-	-		
26	-----	-	-	-		
27	03554220	1	1	1		
28	03468940	1	1	1		
29	40081700	1	1	1	D1	12 x 2
30	03469010	1	1	1		
31	50127500	1	1	1		3 x 14 DIN 1481
32	01086200	1	1	1		L 40 (Nr. 12)
33	01213800	1	1	1		Nr. 1
33	01538600	1	1	1		Nr. 7
33	01555100	1	1	1		Nr. 8
33	01561400	1	1	1		Nr. 9
33	01561500	1	1	1		Nr. 10
33	01561600	1	1	1		Nr. 11
33	01086200	1	1	1		Nr. 12
34	03469120	1	1	1		

M 04

Drehzahlverstellung
Speed control
Reglage regime
Ajuste de revoluciones
Comando acceleratore

Tafel Nr.
Tabl. No.
Tavola N.

08

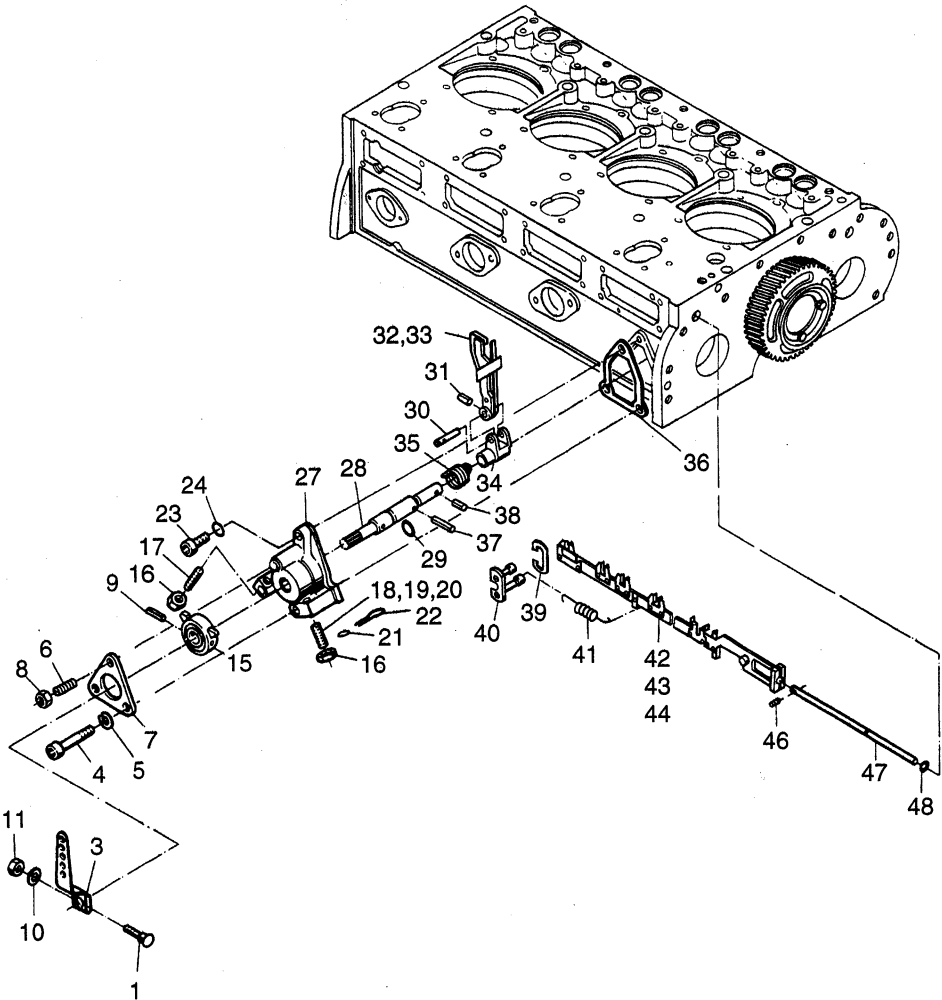

Fig.- No.	HATZ Ident-No.	Stück Qty.			P / W d / D	Bemerkungen Notes	
		2L..C	3L..C	4L..C/K			
35	03861400	1	1	1			
36	03465900	1	1	1	D1		
37	50269000	1	1	1		4 x 26	DIN 1481
38	50131900	1	1	1		4 x 12	DIN 1481
39	03865010	0...3	0...3	0...3			
40	01066701	1	1	1			
41	03468100	1	1	1			
42	01066802	1	-	-			
43	01066902	-	1	-			
44	01067002	-	-	1			
46	50131800	1	1	1		2,5 x 10	DIN 1481
47	03460600	1	1	1			
48	40022300	1	1	1	D1	8 x 2	

M 05

Kolben, Pleuel
Piston, conrod
Piston, bielle
Embolo, biela
Pistone, biella

M 06

Zylinder
Cylinder
Cylindre
Cilindro
Cilindro

Tafel Nr.
Tabl. No.
Tavola N.

09

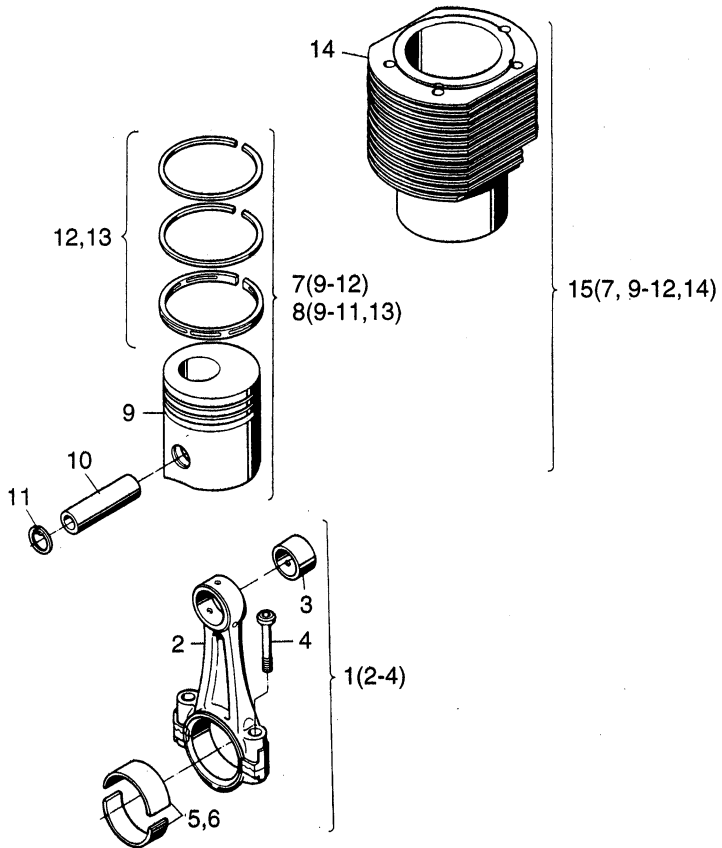

Fig.- No.	HATZ Ident-No.	Stück Qty.			P / W d / D	Bemerkungen Notes
		2L..C	3L..C	4L..C/K		
1	00929703	2	3	4		
2	-----	-	-	-		
3	03753000	2	3	4		
4	03775210	4	6	8		
5	03618401	2	3	4		
6	03753100	2	3	4		- 0,5 mm
7	00954103	2	3	4		L 40
7	01322803	2	3	4		L 41
8	01235702	2	3	4		+ 0,5 mm L 40
8	01323003	2	3	4		+ 0,5 mm L 41
9	-----	-	-	-		
10	50236100	2	3	4		
11	50349100	4	6	8		BS 36/3
12	00955801	2	3	4		
13	01235801	2	3	4		+ 0,5 mm
14	-----	-	-	-		
15	00973401	2	3	4		L 40
15	01544700	2	3	4		L 41

M 07

Zylinderkopf
Cylinder head
Culasse
Culata
Testa

Tafel Nr.
Tabl. No.
Tavola N.

10

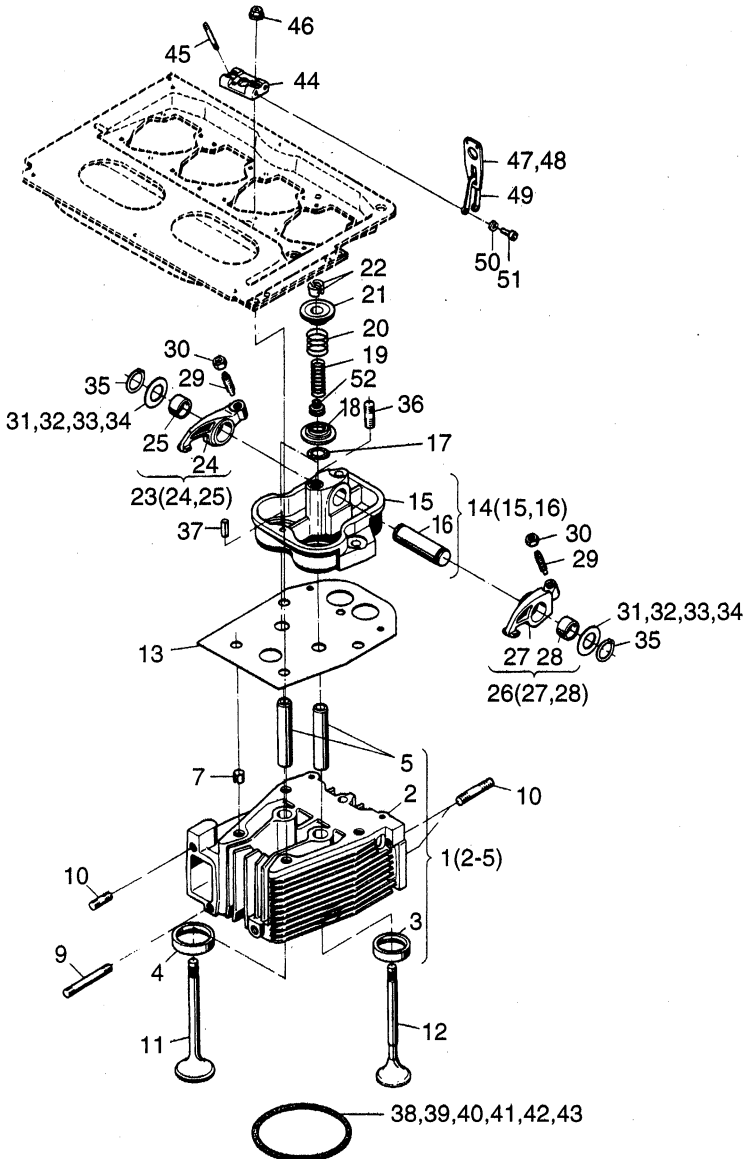

Fig.- No.	HATZ Ident-No.	Stück Qty.			P / W d / D	Bemerkungen Notes
		2L..C	3L..C	4L..C/K		
1	00933001	2	3	4		L40C (L) > 2300 min ⁻¹
1	00993600	2	3	4		L40CH / KH (H)
1	01317510	2	3	4		L 41
2	-----	-	-	-		
3	-----	-	-	-		
4	-----	-	-	-		
5	04037700	4	6	8		
6	-----	-	-	-		
7	04103700	8	12	16		13 x 14
8	-----	-	-	-		
9	50132500	2	3	4		M 8 x 65 DIN 835-8.8
10	50128100	6	9	12		M 8 x 30 DIN 835-10.9 A3C
11	03625501	2	3	4		L 40
11	04108400	2	3	4		L 41
12	03625600	2	3	4		L 40
12	04108500	2	3	4		L 41
13	03624801	2	3	4		
14	00956200	2	3	4		
15	-----	-	-	-		
16	03469800	2	3	4		
17	50288100	4	6	8	d2	
18	03393010	4	6	8		
19	03183500	4	6	8		„C“ (L) > 2300 min ⁻¹
20	03325600	4	6	8		
21	03043402	4	6	8		
22	03620900	4	6	8		
23	00532500	2	3	4		
24	-----	-	-	-		
25	03184100	2	3	4		
26	00932800	2	3	4		
27	-----	-	-	-		
28	03184100	2	3	4		
29	03772000	4	6	8		
30	03149000	4	6	8		
31	03580600	0...4	0...6	0...8		0,15 mm
32	03233200	0...4	0...6	0...8		0,20 mm
33	03233300	0...4	0...6	0...8		0,30 mm
34	03456000	0...4	0...6	0...8		0,40 mm
35	50020200	4	6	8		A 19 x 1,2 DIN 471
36	50040500	2	3	4		M 10 x 25 DIN 939-5.6

M 07

Zylinderkopf
Cylinder head
Culasse
Culata
Testa

Tafel Nr.
Tabl. No.
Tavola N.

10

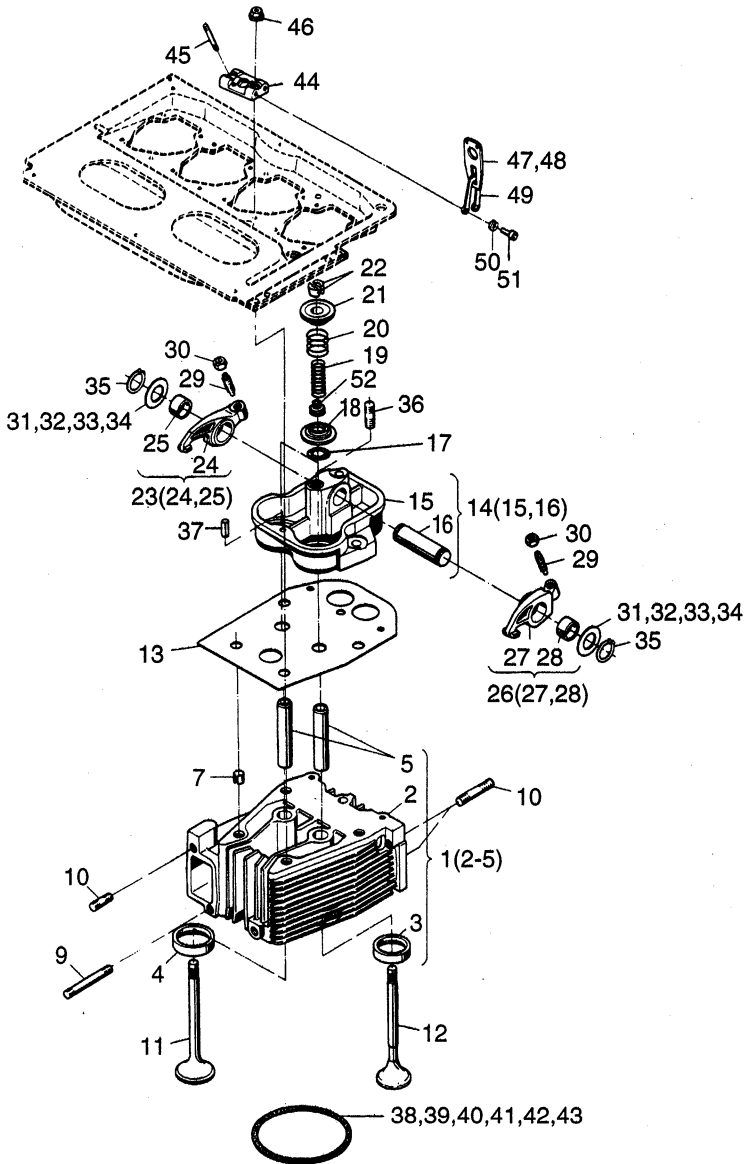

Fig.- No.	HATZ Ident-No.	Stück Qty.			P / W d / D	Bemerkungen Notes
		2 L.. C	3 L.. C	4 L.. C/K		
37	50035200	2	3	4		6 x 12 DIN 1481
38	03625901	0...2	0...3	0...4		0,7 mm
39	03626001	0...2	0...3	0...4	d1	0,8 mm
40	03626101	0...2	0...3	0...4		0,9 mm
41	03626201	0...2	0...3	0...4	d1	1,0 mm
42	03626301	0...2	0...3	0...4		1,1 mm
43	03626401	0...2	0...3	0...4		1,2 mm
44	03624900	2	3	4		L 40
44	04108600	2	3	4		L 41
45	50239000	4	6	8		M 8 x 55 DIN 939-8.8
46	03648100	10	15	20	P5	
47	-----	-	-	-		
48	03592000	1	1	1		C/K
49	03625000	1	1	1		
50	50002800	2	2	2		8 DIN 128
51	50129700	2	2	2		M 8 x 18 DIN 912-10.9
52	50284800	4	6	8	d2	

M 09

Stoßstange
Pushrod
Tige de culbuteur
Varilla de balacin
Asta bilancieri

M 10

Ölpumpe
Oil pump
Pompe a huile
Bomba de aceite
Pompa olio

Tafel Nr.
Tabl. No.
Tavola N.

11

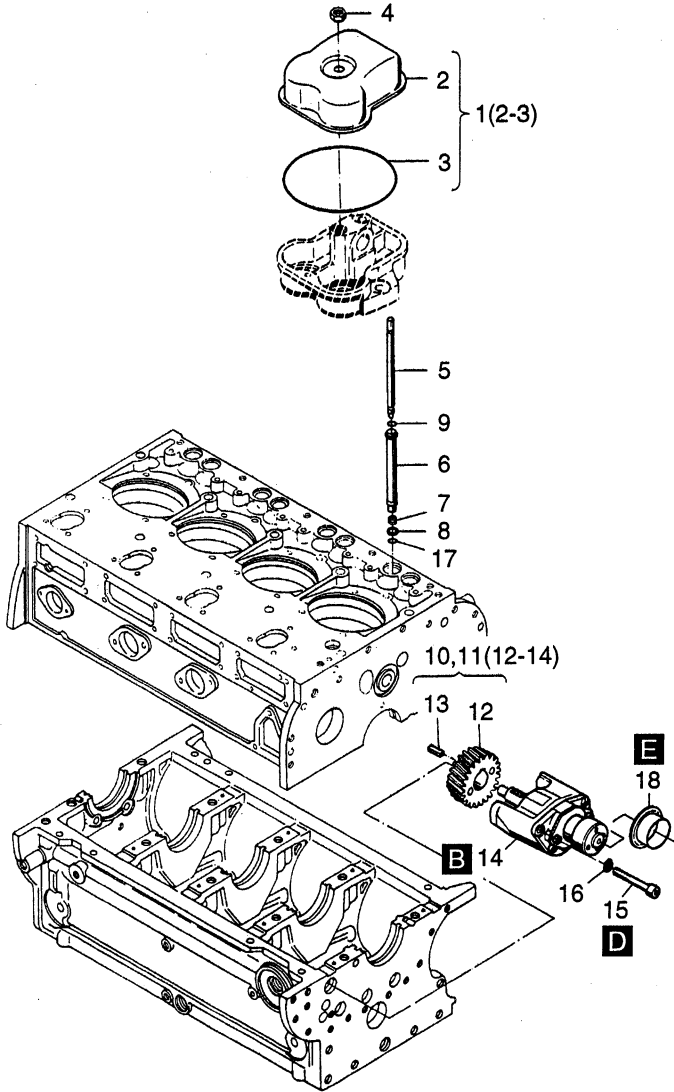

Fig.- No.	HATZ Ident-No.	Stück Qty.	P / W d / D	Bemerkungen Notes	
		2 L.. C	3 L.. C	4 L.. C/K	
1	01205900	2	3	4	
2	-----	-	-	-	
3	50224900	2	3	4	W4/6/8 123 x 2,5
4	50132300	2	3	4	W2/3/4 M 10
5	00743600	4	6	8	
6	03566701	4	6	8	
7	03185100	4	6	8	
8	03185200	4	6	8	
9	50288000	4	6	8	d2 17 x 3
10	00924204	1	1	-	
11	00923904	-	-	1	
12	03562020	1	1	1	
13	50316800	1	1	1	4 x 4 x 20 DIN 6885
14	-----	-	-	-	
15	50206800	3	3	3	M 8 x 105 DIN 912-8.8
16	50002800	3	3	3	8 DIN 128
17	50288100	4	6	8	d2 15 x 3,2
18	50289400	0...1	0...1	0...1	55 mm

Steuergehäuse
Timing cover
Couvercle distribution
Tapa de mando
Coperchio distribuzione

M 11

Tafel Nr.
Tabl. No.
Tavola N.

12

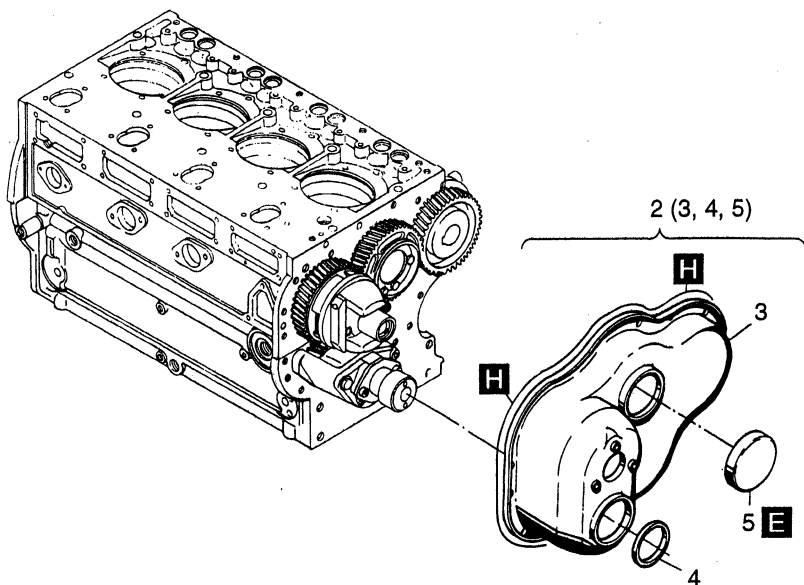
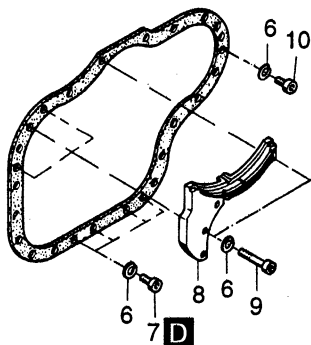

Fig.- No.	HATZ Ident-No.	Stück Qty.	P / W d / D	Bemerkungen Notes
2..4L..C/K				
1	-----	-		
2	00993200	1		
3	-----	-		
4	50129100	1	D1	55 x 70 x 8
5	50126500	1		70 DIN 442
6	50002800	22		8 DIN 128
7	50205800	4		M 8 x 12 DIN 912-8.8
8	00902800	1		
9	50052800	5		M 8 x 55 DIN 912-8.8
10	50051600	13		M 8 x 16 DIN 912-8.8

M 12

Startfüllung
Extra fuel device
Sucharge
Sobre aliment.-arranque
Supplemento

Tafel Nr.
Tabl. No.
Tavola N.

13

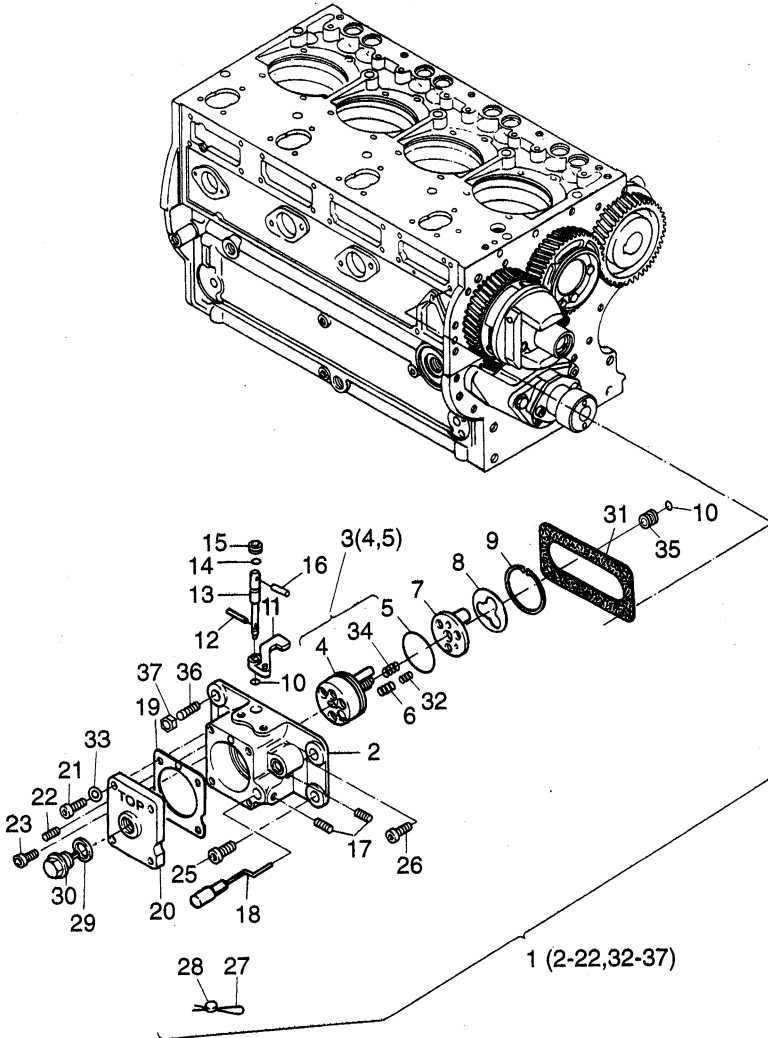

Fig.- No.	HATZ Ident-No.	Stück Qty.	P / W d / D	Bemerkungen Notes
2..4L..C/K				
1	01586900	1		
2	-----	-		
3	01201820	1		
4	-----	-		
5	50263100	1		37,5 x 1,5
6	03881100	3		
7	03854210	1		
8	03929700	1		
9	50021500	1		J 42 x 1,75
10	50117200	2		4 DIN 6799
11	03670210	1		
12	50131800	1		2,5 x 10 DIN 1481
13	03828810	1		
14	40021700	1		4,47 x 1,78
15	50324400	1		
16	50034300	1		3 x 36 DIN 1481
17	50262300	2		M 4 x 10 DIN 915-45H TU
18	01076210	1		
19	03934400	1		
20	01162100	1		
21	50416800	4		M 6 x 16 DIN 912-8.8 A3C
22	50262400	3		M 6 x 10 DIN 916-45H TU
23	50134900	1		M 8 x 16 DIN 6912-8.8
25	50128900	1		M 8 x 16 DIN 912-8.8
26	03960300	1		M 8 x 20
27	40021500	1		0,5/0,3
28	40021400	1		8 mm
29	50001200	1		A 14 x 18 DIN 7603-Cu
30	01097800	1		
31	03614001	1		
32	03935200	3		
33	50170900	4		6 DIN 128
34	03617800	1		
35	03841800	1		
36	04123900	1		M 8 x 19 Tuf.
37	40028400	1		VM 8 990-8 C3A

M 13

Gebläse
Blower
Soufflerie
Ventilador
Ventilatore

Tafel Nr.
Tabl. No.
Tavola N.

14

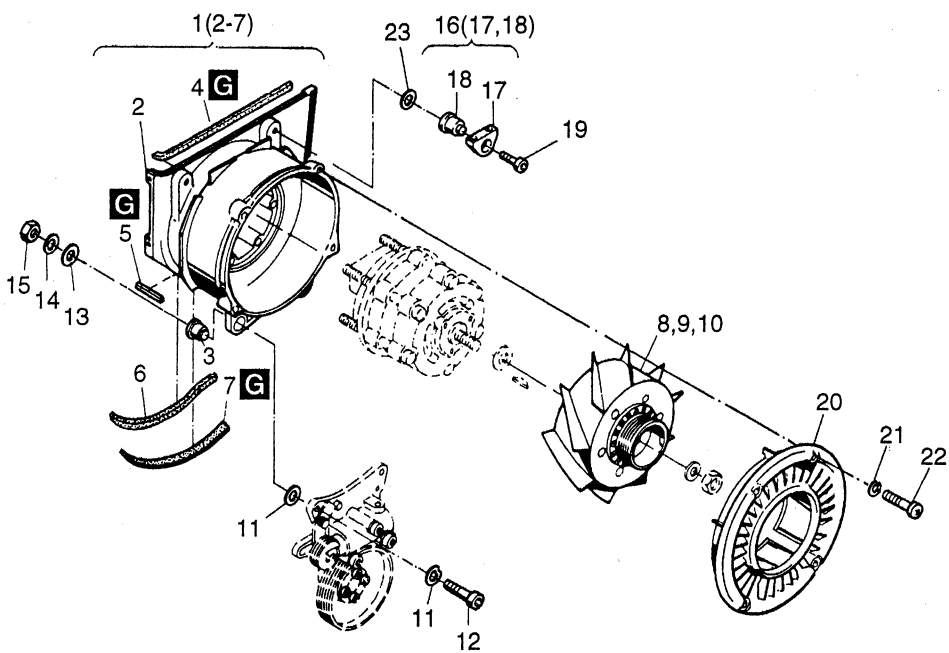

Fig.- No.	HATZ Ident-No.	Stück Qty.			P / W d / D	Bemerkungen Notes
		2 L.. C	3 L.. C	4 L.. C/K		
1	01203701	-	1	1		
2	-----	-	-	-		
3	03562500	2	2	2		
4	03552600	1	1	1		335 mm
5	03598500	1	1	1		33 mm
6	03552401	1	1	1		240 mm
7	03612700	-	-	1		193 mm
8	01205201	2	-	-		2 L 40 C, 2 L 41 C
9	00999101	-	1	-		3 L 40 C, 3 L 41 C
10	00989701	-	-	1		4 L 40/41 C/K
11	50061700	4	4	4		A 10 DIN 137
12	50055100	2	2	2		M 10 x 55 DIN 912-8.8
13	50070600	2	2	2		10,5 DIN 7349
14	50002900	2	2	2		A 10 DIN 128
15	50023500	2	2	2		M 10 DIN 934-8
16	00919800	2	2	2		
17	-----	-	-	-		
18	03562500	2	2	2		
19	50052600	2	2	2		M 8 x 45 DIN 912-8.8
20	03762800	1	1	1		
21	50081200	4	4	4		A 6 DIN 137
22	50253200	4	4	4		M 6 x 50 DIN 7985-4.8 A3R
23	03595600	0...4	0...4	0...4		

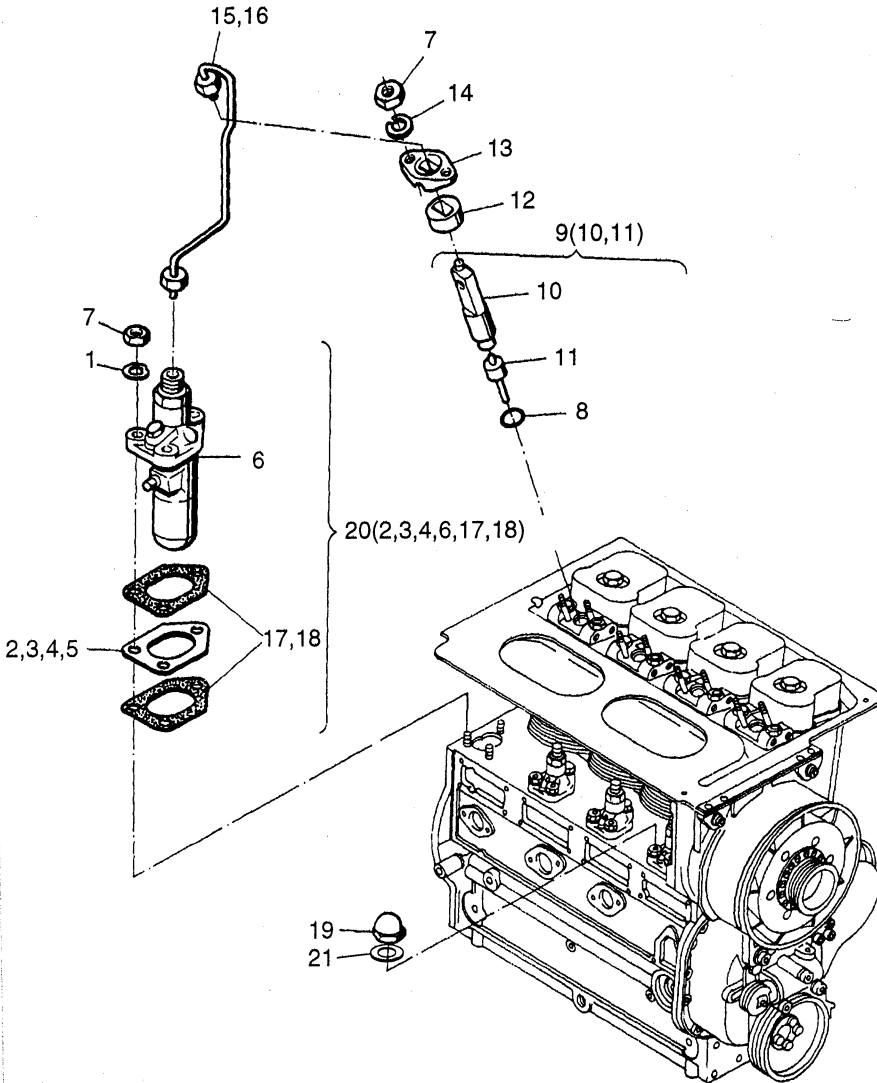

Fig.- No.	HATZ Ident-No.	Stück Qty.			P / W d / D	Bemerkungen Notes
		2 L..C	3 L..C	4 L..C/K		
1	50003500	6	9	12		B8 DIN 137
2	03168701	0...2	0...3	0...4		0,30 mm
3	03897100	0...2	0...3	0...4		0,60 mm
4	03897200	0...2	0...3	0...4		0,90 mm
5	03897300	0...2	0...3	0...4		1,20 mm
6	-----	-	-	-		
7	50022900	9	14	19	P4	M 8 DIN 934-8
8	40085001	2	3	4	d1	
8	04107300	2	3	4		L 41
9	40120901	2	3	4		
9	50444000	2	3	4		L 41
10	-----	-	-	-		
11	50141301	2	3	4	P1	L 40
11	50444100	2	3	4	P1	L 41
12	03466500	2	3	4		
13	03460500	2	3	4		
14	50002800	4	6	8	P4	8 DIN 128
15	01203800	2	3	4		L 40 C, L 41C
16	00740600	2	3	4		L 40 CH / KH (H)
17	03896802	0...4	0...6	0...8	D4	0,20 mm
18	03896902	0...4	0...6	0...8	D4	0,30 mm
19	50267600	1	1	1		M 8 DIN 1587
20	01268500	2	3	4		L 40 C
20	01544800	2	3	4		L 41 C
21	50162900	1	1	1		A 8 x 14 DIN 7603-Cu

M 16

Riemenscheibe
Pulley
Poulie
Polea
Puleggia

M 17

Schwungrad
Flywheel
Volant
Volante
Volano

M 20

Hydr. Abstellvorr.
Hydr. belt tensioner
Tendeur hydr.
Tensor hidr.
Tendiciniglia idraulico

Tafel Nr.
Tabl. No.
Tavola N.

16

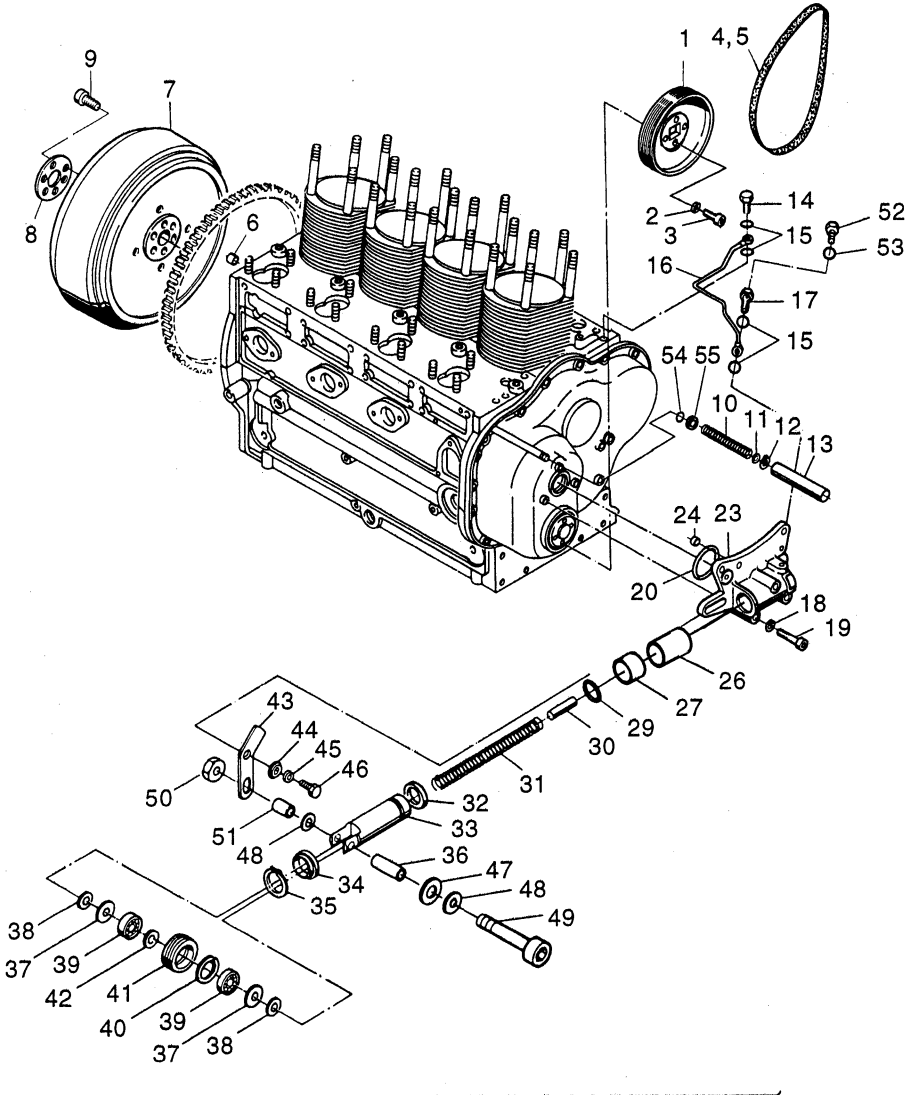

21 (23-24,26-27,29-51)

Fig.- No.	HATZ Ident-No.	Stück Qty.		P / W d / D	Bemerkungen Notes
		2 L.. C	3-4 L.. C/K		
1	03589801	1	1		
2	50002800	4	4		
3	50051900	4	4		8 DIN 128 M 8 x 20 DIN 912-8.8
4	50141500	-	1	P1	9 J 910
5	50203100	1	-	P1	9 J 920
6	03630600	1	1		
7	03733701	1	1		SAE J 620
8	03645800	1	1		
9	50225100	6	6		M 14 x 1,5 x 45 DIN 912-10.9
10	03468000	1	1		
11	03133200	1	1		
12	50019400	1	1		8 x 0,8 DIN 471
13	03568200	1	1		
14	50006100	1	1		A 4-5-3 DIN 7643
15	50000900	4	4		A 8 x 11,5 DIN 7603-Cu
16	00910000	1	1		
17	03724800	1	1		
18	50003500	3	3		B 8 DIN 137
19	50081800	3	3		M 8 x 65 DIN 912-8.8
20	50132401	1	1	D1	
21	00995503	1	1		
22	-----	-	-		
23	-----	-	-		
24	40084700	1	1		
25	-----	-	-		
26	50220900	1	1		
27	50220800	1	1		
28	-----	-	-		
29	50219700	1	1		
30	03639300	1	1		
31	03589100	1	1		
32	50221100	1	1		
33	03589622	1	1		
34	03643001	1	1		
35	50290400	1	1		JW 45 x 1,75 DIN 472
36	03764600	1	1		

M 16

Riemenscheibe
Pulley
Poulie
Polea
Puleggia

M 17

Schwungrad
Flywheel
Volant
Volante
Volano

M 20

Hydr. Abstellvorr.
Hydr. belt tensioner
Tendeur hydr.
Tensor hidr.
Tendiciniglia idraulico

Tafel Nr.
Tabl. No.
Tavola N.

16

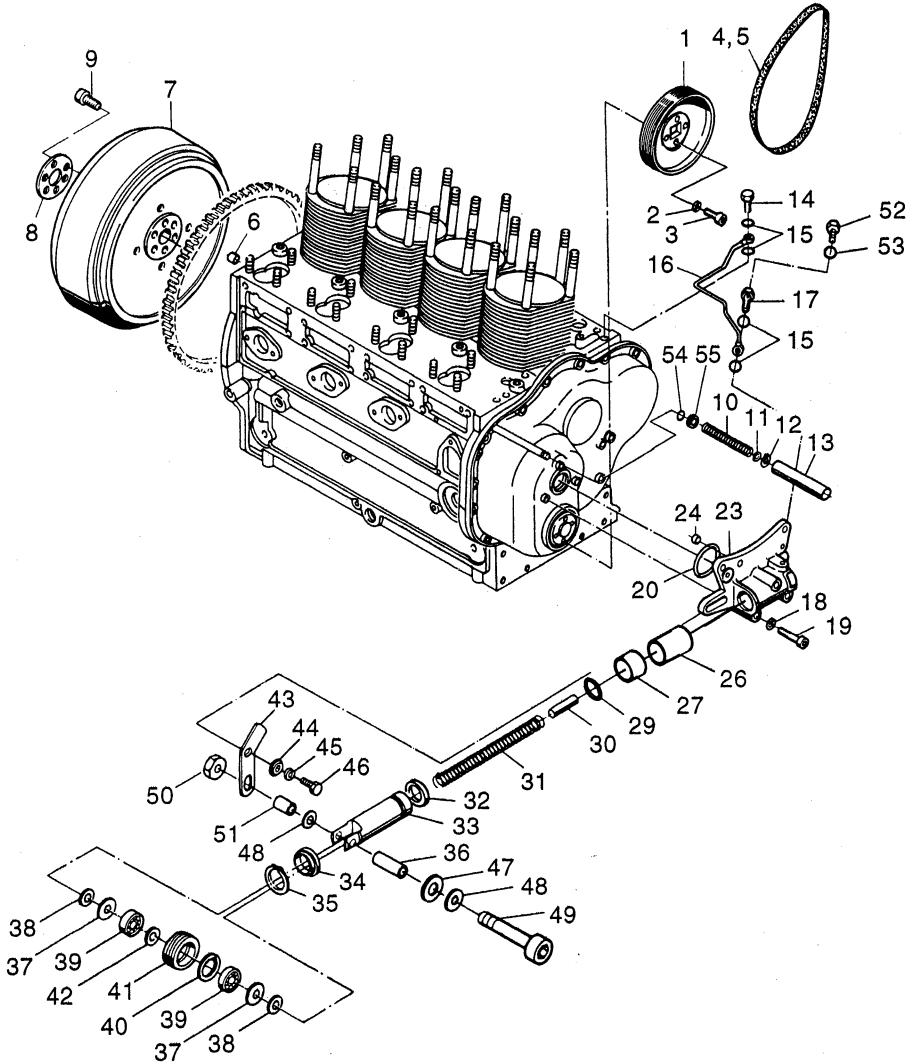

21 (23-24,26-27,29-51)

Fig.- No.	HATZ Ident-No.	Stück Qty.	P / W d / D	Bemerkungen Notes
		2 L.. C	3 - 4 L.. C/K	
37	50250000	2	2	
38	03764800	2	2	
39	50249900	2	2	
40	50020700	1	1	J 28 x 1,2 DIN 472
41	03589421	1	1	
42	50132100	1	1	12 x 18 x 1,2
43	03589510	1	1	
44	03589300	1	1	
45	50002700	1	1	6 DIN 128
46	50025800	1	1	M 6 x 20 DIN 933-8.8
47	03764900	1	1	8,4 x 40 x 1
48	50148100	2	2	A 8,4 DIN 125 St A3C
49	50081800	1	1	M 8 x 65 DIN 912-8.8
50	40028400	1	1	M 8 SSN 440-8 Cu
51	03764700	1	1	
52	50025300	1	1	M 6 x 8 DIN 933-8.8
53	50000800	1	1	A 6,5 x 9,5 DIN 7603-Cu
54	50346700	1	1	7,5 x 2,5
55	04102700	1	1	

M 22 Luftfilter
 Air filter
 Filtre à air
 Filtro de aire
 Filtro aria

M 27 Luftansaugrohr
 Air intake manifold
 Collecteur d'admission
 Tubo de aspiración
 Collettore aspirazione

Tafel Nr.
 Tabl. No.
 Tavola N.
17

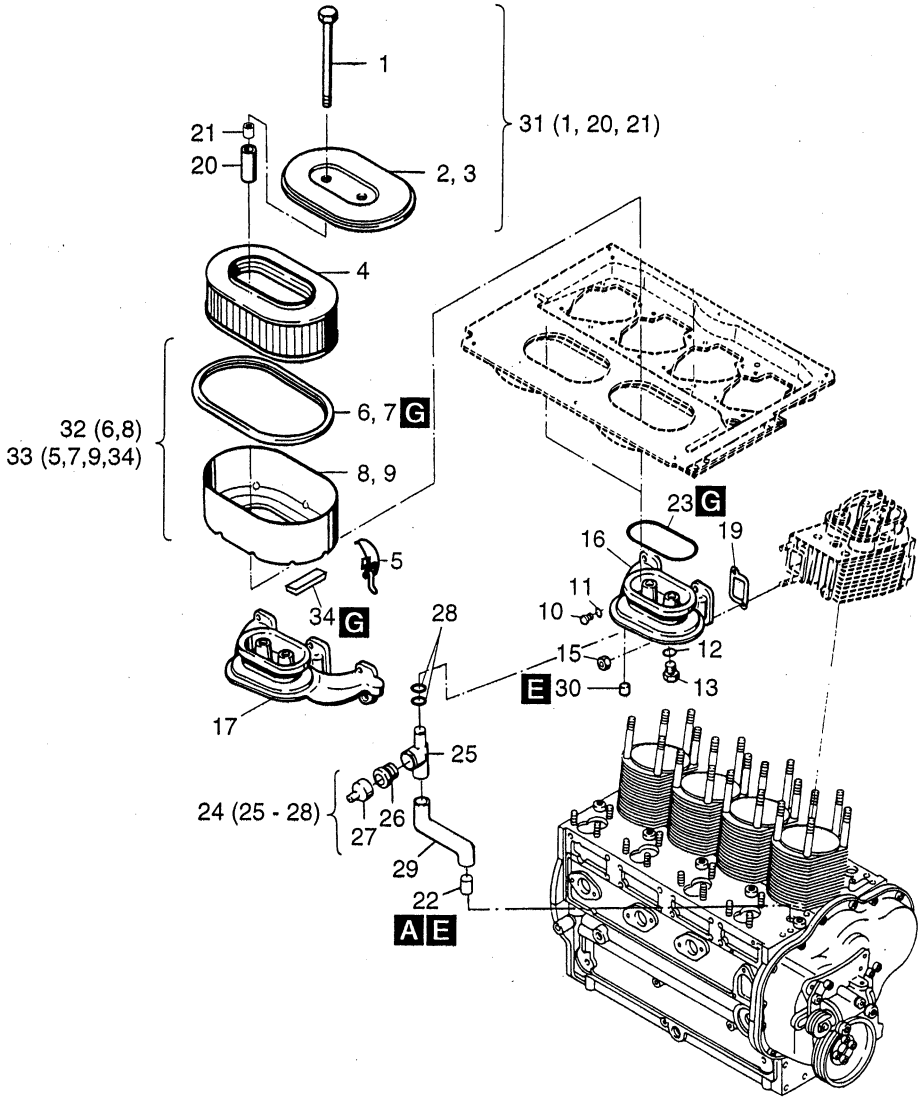

Fig.- No.	HATZ Ident-No.	Stück Qty.			P / W d / D	Bemerkungen Notes
		2L..C	3L..C	4L..C/K		
1	-----	-	-	-		
2	00953001	1	-	2		
3	00999500	-	1	-		
4	00952900	1	1	2	W2/4	
5	50257400	-	1	-		
6	03647600	1	-	2	W1/2	
7	03769800	-	1	-	W1	
8	-----	-	-	-		
9	-----	-	-	-		
10	50062300	1	1	2		M 10 x 1 DIN 908
11	50062400	1	1	2		A 10 x 13,5 DIN 7603-Cu
12	50001600	1	1	2		A 22 x 27 DIN 7603-Cu
13	50140400	1	1	2		AM 22 x 1,5 DIN 7604
14	-----	-	-	-		
15	40028400	4	6	8	P4	VM 8 DIN 980-8 C3A
16	03624304	1	-	2		
17	03632103	-	1	-		
18	-----	-	-	-		
19	03624402	2	3	4	d1	
20	-----	-	-	-		
21	04085700	2	2	4		10 x 7 x 10
22	03649000	1	1	1		
23	03648600	1	1	2		
24	00947801	1	1	1		
25	-----	-	-	-		
26	03568700	1	1	1		
27	03568600	1	1	1		
28	50326700	2	2	2	D2	9,7 x 1
29	03648900	1	1	1		
30	03756700	-	-	1		11,8
31	01494000	2	2	4		
32	00953300	1	-	2		
33	00999600	-	1	-		
34	04119000	-	1	-		90 mm

M 26 Luftführung
Air ducting
Carter ventilation
Conducción de aire
Carter ventilatore

Tafel Nr.
Tabl. No.
Tavola N.
18

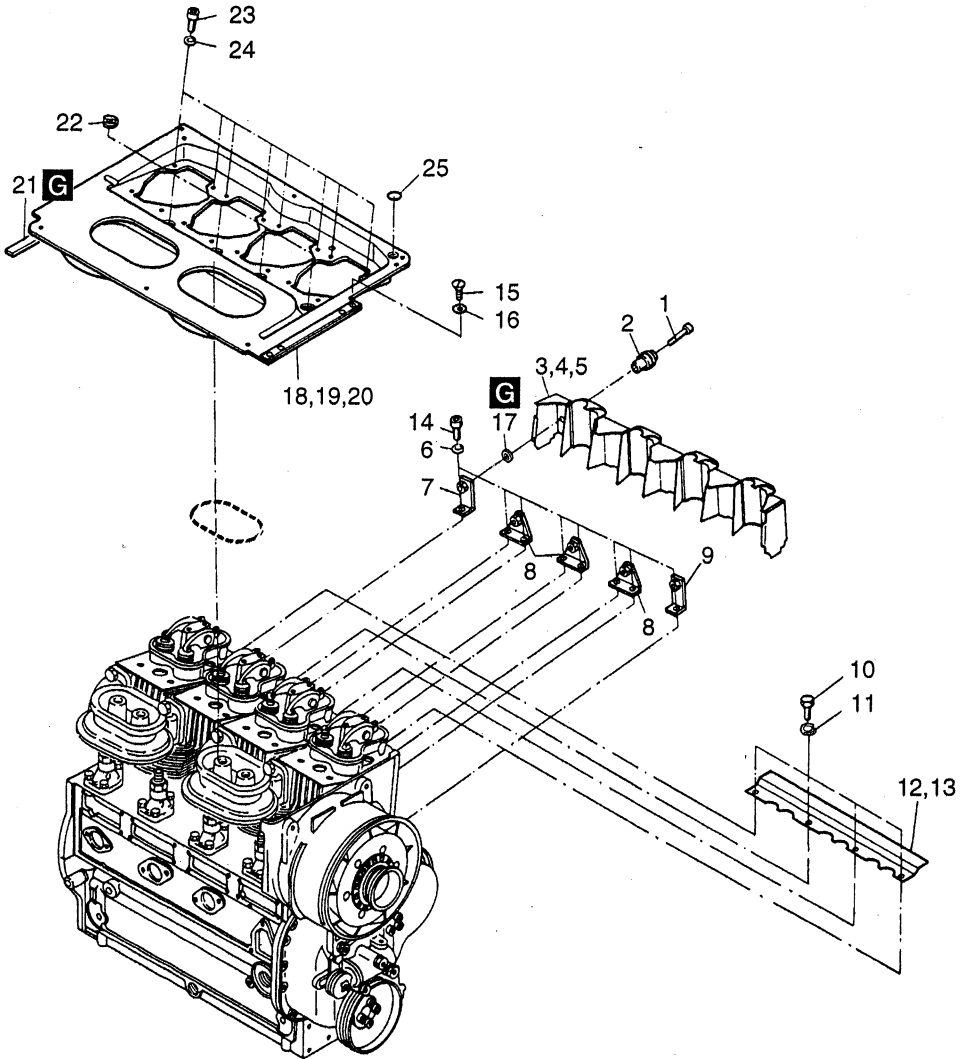

Fig.- No.	HATZ Ident-No.	Stück Qty.	P / W d / D	Bemerkungen Notes	
		2L..C	3L..C	4L..C/K	
1	50051000	3	4	5	M 6 x 30 DIN 912-8.8
2	00932700	3	4	5	
3	00938000	1	-	-	
4	00938100	-	1	-	
5	00938200	-	-	1	
6	50002800	4	6	8	8 DIN 128
7	00923400	1	1	1	
8	00923300	1	2	3	
9	00923500	1	1	1	
10	50026600	2	3	-	M 8 x 12 DIN 933-8.8
11	50002800	2	3	-	
12	03590700	1	-	-	
13	03591501	-	1	-	
14	50051600	4	6	8	M 8 x 16 DIN 912-8.8
15	50205200	4	4	4	P4 M 8 x 16 DIN 965-8.8
16	50205100	4	4	4	P4 V 8,4 DIN 6797
17	03575500	3	4	5	
18	00934302	1	-	-	
19	00939702	-	1	-	
20	00939802	-	-	1	
21	03648500	1	1	1	
22	03592700	2	3	4	P2
23	50050700	4	6	8	P4 M 6 x 16 DIN 912-8.8
24	50081200	4	6	8	P4 A 6 DIN 137
25	01213900	1	1	1	

M 26 Lufführung
 Air ducting
 Carter ventilation
 Conducción de aire
 Carter ventilatore

Tafel Nr.
 Tabl. No.
 Tavola N.

19

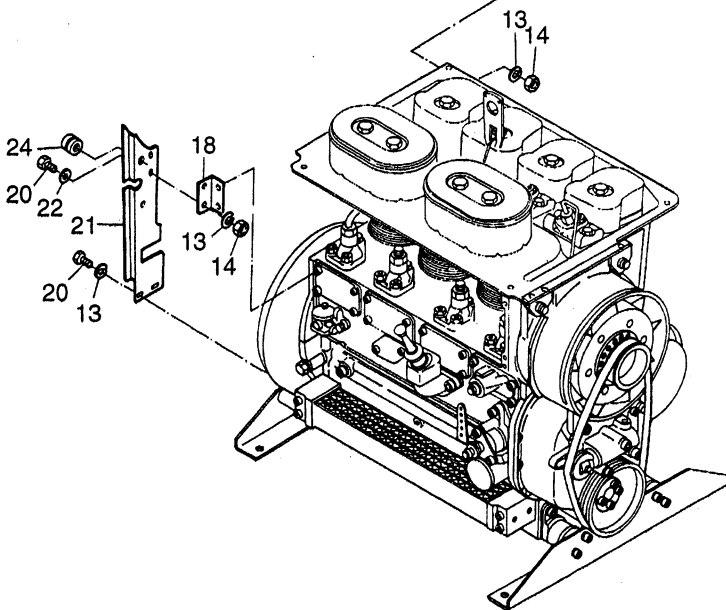
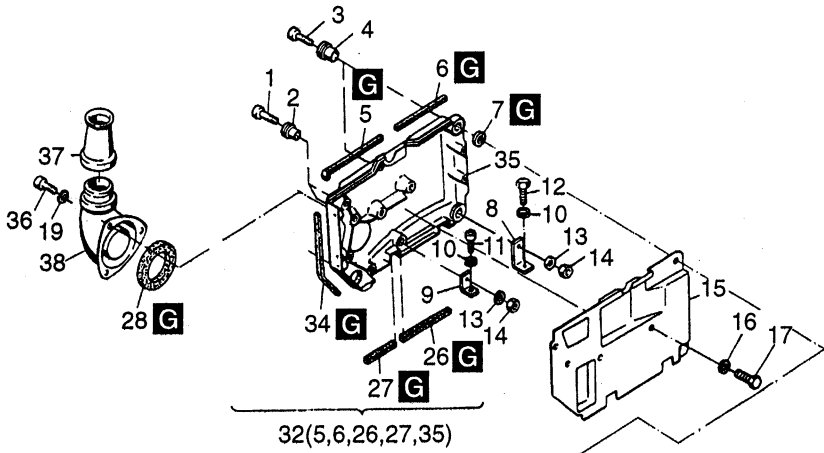

Fig.- No.	HATZ Ident-No.	Stück Qty.	P / W d / D	Bemerkungen Notes
2..4L..C/K				
1	50374900	2		M 6 x 35 DIN 912-8.8 A3C
2	00932700	2		
3	50051000	2		M 6 x 30 DIN 912-8.8
4	00921500	2		
5	04071000	1		209 mm
6	03565100	1		113 mm
7	03575500	4		
8	03646800	1		
9	03646900	1		
10	50002800	2		8 DIN 128
11	50051600	1		M 8 x 16 DIN 912-8.8
12	50026700	1		M 8 x 16 DIN 933-8.8
13	50081200	5		A 6 DIN 137
14	50144400	6		M 6 DIN 934.8.8 A3C
15	03646201	1		
16	50081200	7		A 6 DIN 137
17	50025500	7		6 x 12 DIN 933-8.8
18	03590100	1		
19	50170900	3		6 DIN 128 A3C
20	50025500	4		M 6 x 12 DIN 933-8.8
21	03647201	1		
22	50144500	2		6,4 DIN 125-St A3C
23	-----	-		
24	03565400	1		
26	03565100	1		113 mm
27	04071100	1		88 mm
28	03647300	1		
29	-----	-		
30	-----	-		
31	-----	-		
32	00953200	1		
33	-----	-		
34	03646300	1		
35	-----	-		
36	50170700	3		M 6 x 16 DIN 912-8.8 A3C
37	03780300	1		
38	01219100	1		

M 35

Kapsel C / K
Capsule C / K
Capsule C / K
Cápsula C / K
Cofanatura C / K

Tafel Nr.
Tabl. No.
Tavola N.

20

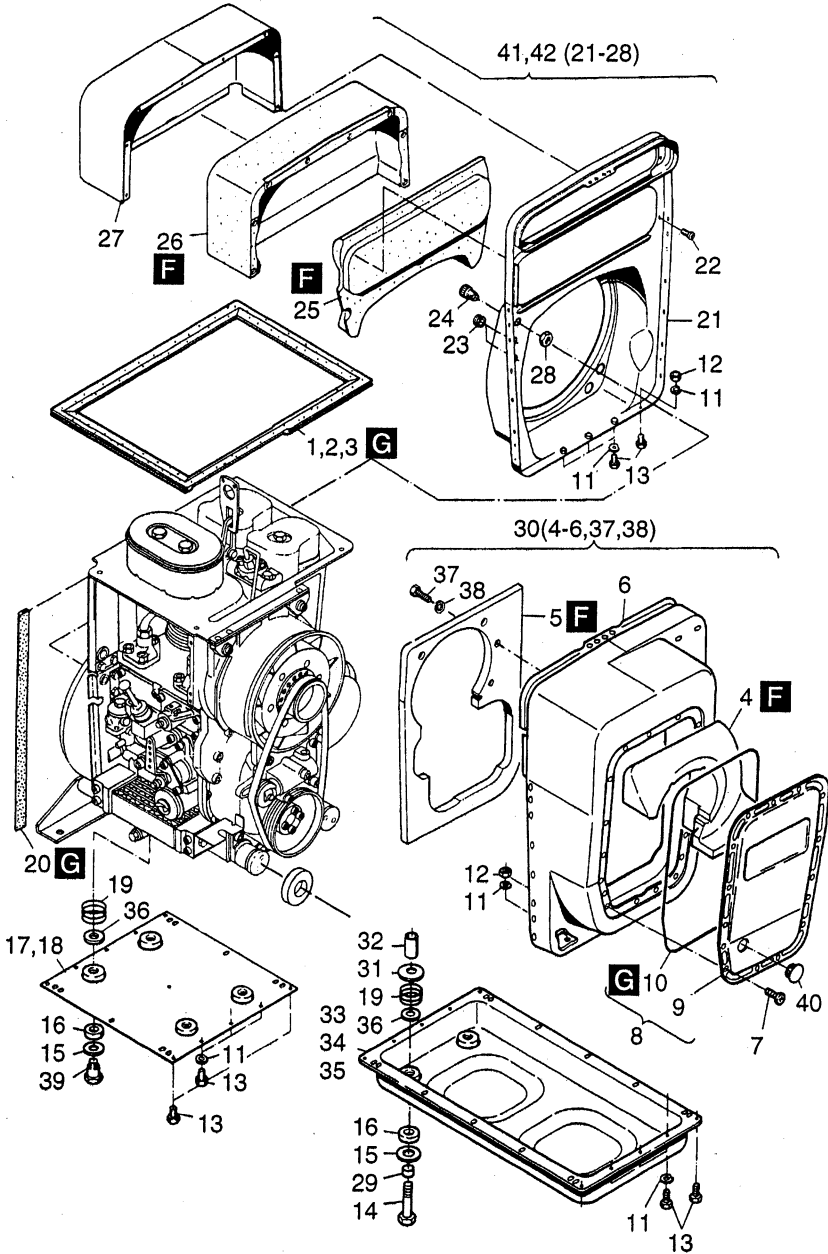

Fig.- No.	HATZ Ident-No.	Stück Qty.	P / W d / D	Bemerkungen Notes	
		2 L..C	3 L..C	4 L..C/K	
1	03616001	1	-	-	
2	03616101	-	1	-	
3	03616201	-	-	1	
4	00995800	1	1	1	
5	03585002	1	1	1	
6	-----	-	-	-	
7	50289200	17	17	17	M 6 x 12 KZ1-8.8 A3D
8	00998510	1	1	1	
9	-----	-	-	-	
10	03765400	1	1	1	
11	50081200	10	10	10	A 6 DIN 137 A3C
12	50144400	4	4	4	M 6 DIN 934-8 A3C
13	50025400	10	10	10	M 6 x 10 DIN 933-8.8
14	50143000	4	4	4	M 12 x 95 DIN 931-8.8
15	03637300	4	4	4	17,2 x 28,1
16	03637200	4	4	4	
17	03752800	1	-	-	
18	03752900	-	1	-	
19	03594900	4	4	4	
20	03643300	1	1	1	
21	00969701	1	-	1	
21	01232700	-	1	-	
22	50289200	8	8	8	M 6 x 12 SB-8.8 A3D
23	03565400	2	2	2	
24	50159011	1	1	1	NH 13,5
25	03647400	1	1	1	
26	03587901	1	1	1	
27	00911101	1	1	1	
28	50159100	1	1	1	PG 13,5
29	03602800	4	4	4	12,1 x 17 x 14,5
30	00950310	1	-	1	
30	01233200	-	1	-	
31	03602600	4	4	4	
32	03602900	4	4	4	
33	00921800	1	-	-	} s. Taf., Tabl. 31 Pos. 15, 16, 17
34	00921900	-	1	-	
35	00922001	-	-	1	
36	03595200	4	4	4	
37	50026600	2	2	2	M 8 x 12 DIN 933-8.8
38	50002800	2	2	2	8 DIN 128
39	03595000	4	4	-	
40	03769301	1	1	1	
41	01466100	1	-	1	
42	01466200	-	1	-	

M 35

Kapsel - Abluftschacht 2-3 L..C
Capsule - air ducting 2-3 L..C
Capsule - carter ventilation 2-3 L..C
Cápsula - chapa de aire 2-3 L..C
Cofanatura - silenzziata 2-3 L..C

Tafel Nr.
Tabl. No.
Tavola N.

21

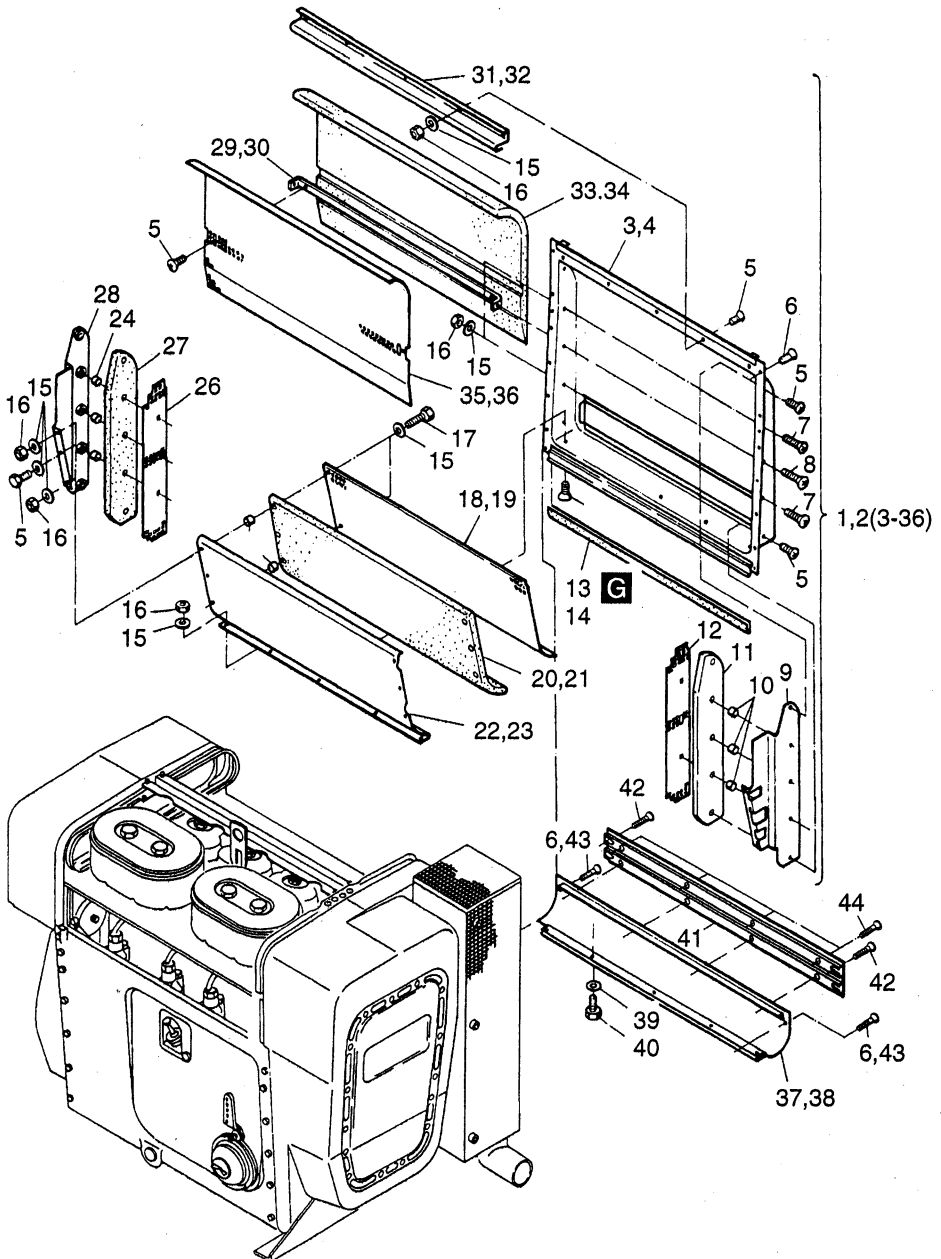

Fig.- No.	HATZ Ident-No.	Stück Qty.	P / W d / D	Bemerkungen Notes
		2 L .. C	3 L .. C	
1	00925601	1	-	
2	00925710	-	1	
3	00748001	1	-	
4	00907010	-	1	
5	50289200	12	15	M 6 x 12 K21-8.8 A3D
6	50289200	14	14	M 6 x 12 K21-8.8 A3D
7	50404400	4	4	M 6 x 35
8	50404400	2	2	M 6 x 35
9	00908401	1	1	
10	03590500	3	3	
11	03587101	1	1	
12	03590801	1	1	
13	03593300	1	-	
14	-----	-	-	
15	50144500	20	22	6,4 DIN 125-St A3C
16	50144400	16	18	M 6 DIN 934-8 A3C
17	50026100	4	4	M 6 x 30 DIN 933-8.8
18	03591000	1	-	
19	03591200	-	1	
20	03587600	1	-	
21	03587700	-	1	
22	00908000	1	-	
23	00908100	-	1	
24	03590500	7	7	
25	-----	-	-	
26	03590801	1	1	
27	03750401	1	1	
28	00908301	1	1	
29	03590600	1	-	
30	03591300	-	1	
31	03584701	1	-	
32	03584801	-	1	
33	03587300	1	-	
34	03587400	-	1	
35	03590900	1	-	
36	03591100	-	1	

M 35

Kapsel - Abluftschacht 2-3 L..C
Capsule - air ducting 2-3 L..C
Capsule - carter ventilation 2-3 L..C
Cápsula - chapa de aire 2-3 L..C
Cofanatura - silenziata 2-3 L..C

Tafel Nr.
Tabl. No.
Tavola N.

21

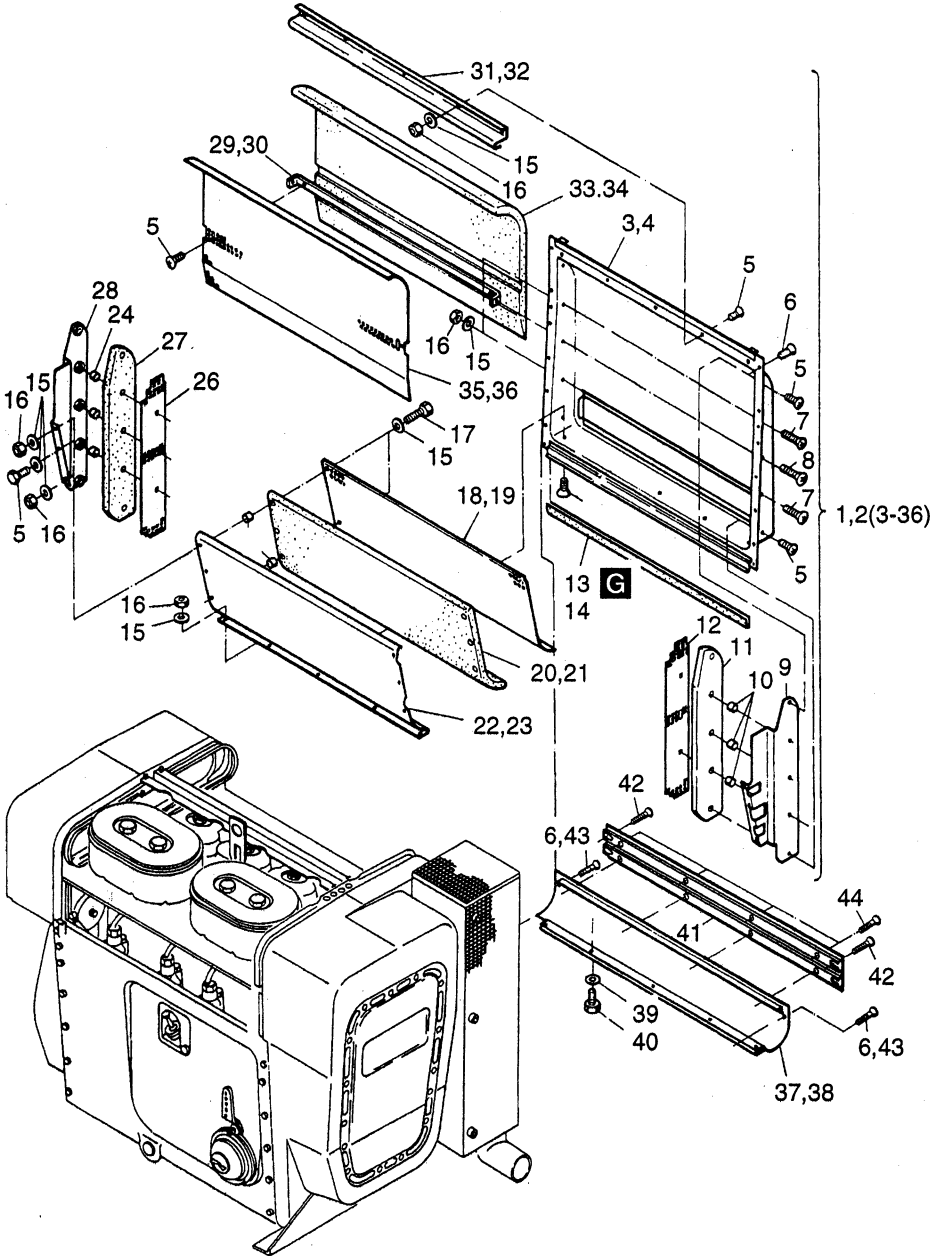

Fig.- No.	HATZ Ident-No.	Stück Qty.	P / W d / D	Bemerkungen Notes
		2 L .. C	3 L .. C	
37	00949900	1	-	
38	00950010	-	1	
39	50144500	3	4	6,4 DIN 125-St. A3C
40	50025400	3	4	M 6 x 10 DIN 933-8.8
41	01232400	-	1	
42	50139000	-	4	M 6 x 10 DIN 912-8.8 C4P
43	50335600	-	4	M 6 x 16 KZ1-8.8 A3D
44	50289200	-	8	M 6 x 12 KZ1-8.8 A3D

M 35

Kapsel - Abluftschacht 4 L..C / K
Capsule -air ducting 4 L..C / K
Capsule - carter ventilation 4 L..C / K
Cápsula - chapa de aire 4 L..C / K
Cofanatura - silenziata 4 L..C / K

Tafel Nr.
Tabl. No.
Tavola N.

22

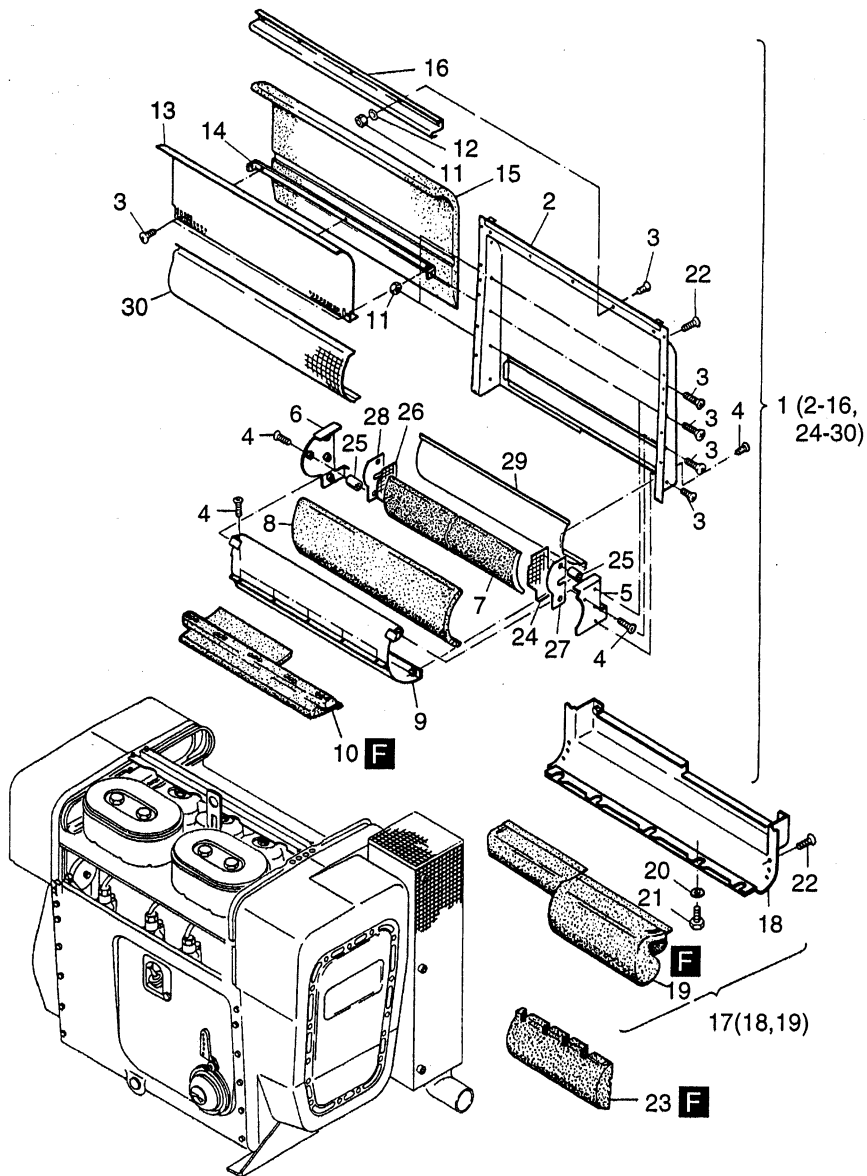

Fig.- No.	HATZ Ident-No.	Stück Qty.	P / W d / D	Bemerkungen Notes
4 L .. C/K				
1	00996802	1		
2	00996010	1		
3	50289200	22		M 6 x 12 SB-8.8 A3D
4	50049300	14		M 5 x 10 DIN 7985-8.8
5	00996200	1		
6	00996300	1		
7	03776800	1		
8	03776700	1		
9	00996401	1		
10	01205500	1		
11	50144400	7		M 6 DIN 934-8 A3C
12	50144500	4		6,4 DIN 125-St A3C
13	03768400	1		
14	03768300	1		
15	03769000	1		
16	03767701	1		
17	00994900	1		
18	-----	-		
19	03767300	1		
20	50144500	5		6,4 DIN 125-St A3C
21	50025400	5		M 6 x 10 DIN 933-8.8
22	50289200	14		M 6 x 12 SB-8.8 A3D
23	03768700	1		
24	03776200	1		
25	03776300	6		
26	03776400	1		
27	03776500	1		
28	03776600	1		
29	03776100	1		
30	03776000	1		

M 35

Kapsel C / K
Capsule C / K
Capsule C / K
Cápsula C / K
Cofanatura silenziosa C / K

Tafel Nr.
Tabl. No.
Tavola N.

23

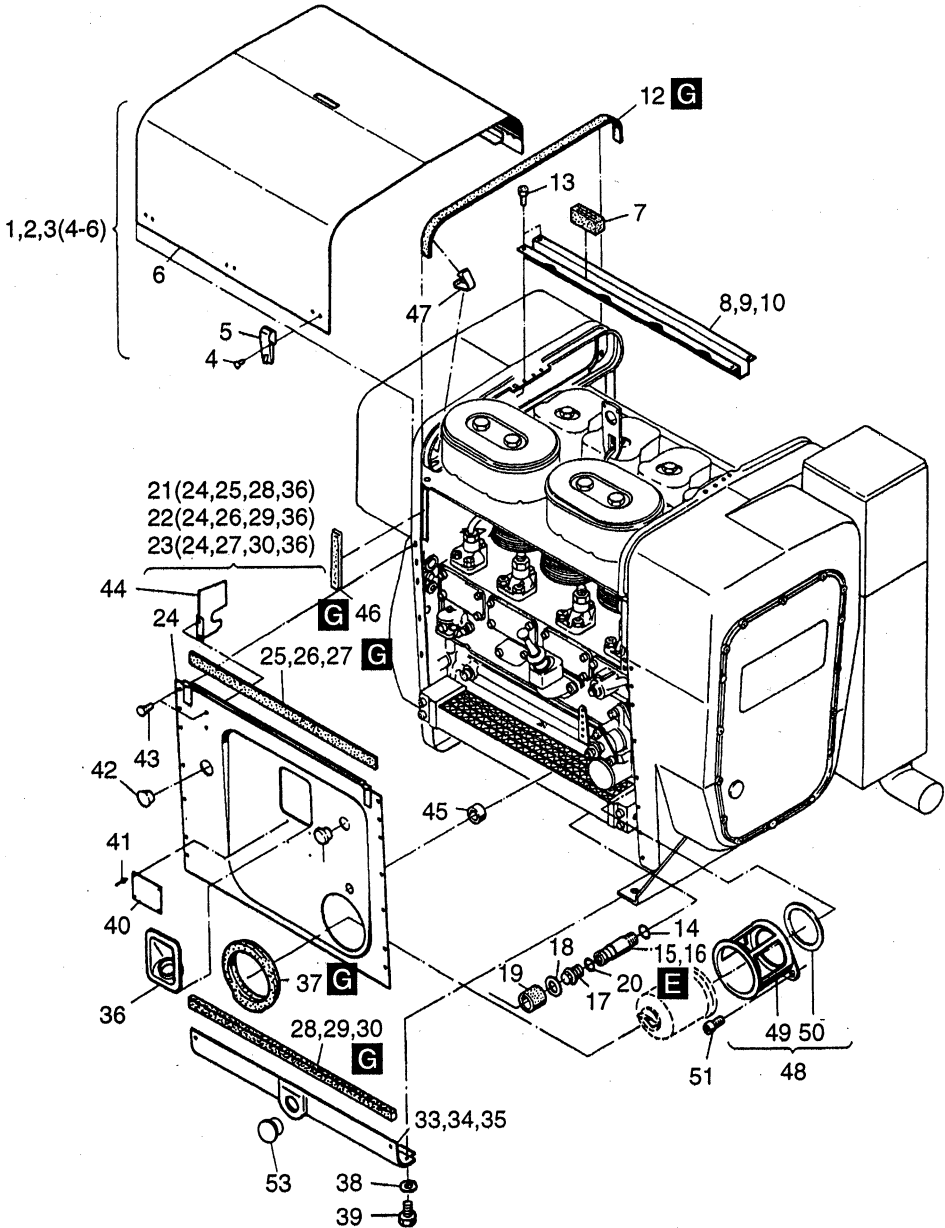

Fig.- No.	HATZ Ident-No.	Stück Qty.			P / W d / D	Bemerkungen Notes
		2 L..C	3 L..C	4 L..C/K		
1	00902401	1	-	-		
2	00906801	-	1	-		
3	00906901	-	-	1		
4	50140200	8	8	12		3,5 x 8 DIN 660 MUST 34
5	40121310	4	4	6		
6	-----	-	-	-		
7	03569000	1	1	1		
8	03578800	1	-	-		
9	03582600	-	1	-		
10	03582700	-	-	1		
11	-----	-	-	-		
12	03577600	2	2	2		650 mm
13	50289200	4	4	4		M 6 x 12 KZ1
14	50001600	1	1	1	W4	A 22 x 27 DIN 7603-Cu
15	03550500	1	1	-		
16	03647500	1	1	1		f. Taf. / Tabl. 31 Pos. 15 - 17
17	50044200	1	1	1	W1	M 18 x 1,5 DIN 910
18	03592301	1	1	1		
19	03579500	1	1	1		
20	50001400	1	1	1	W4,D2	A 18 x 22 DIN 7603-Cu
21	00935320	1	-	-		
22	01096911	-	1	-		
23	00935520	-	-	1		
24	-----	-	-	-		
25	03593300	1	-	-		
26	03593400	-	1	-		
27	03593500	-	-	1		
28	03623710	1	-	-		
29	03623810	-	1	-		
30	03623910	-	-	1		
31	-----	-	-	-		
32	-----	-	-	-		
33	00974100	1	-	-		
34	00974200	-	1	-		
35	00974301	-	-	1		

M 35
 Kapsel C / K
 Capsule C / K
 Capsule C / K
 Cápsula C / K
 Cofanatura silenziosa C / K

Tafel Nr.
 Tabl. No.
 Tavola N.

23

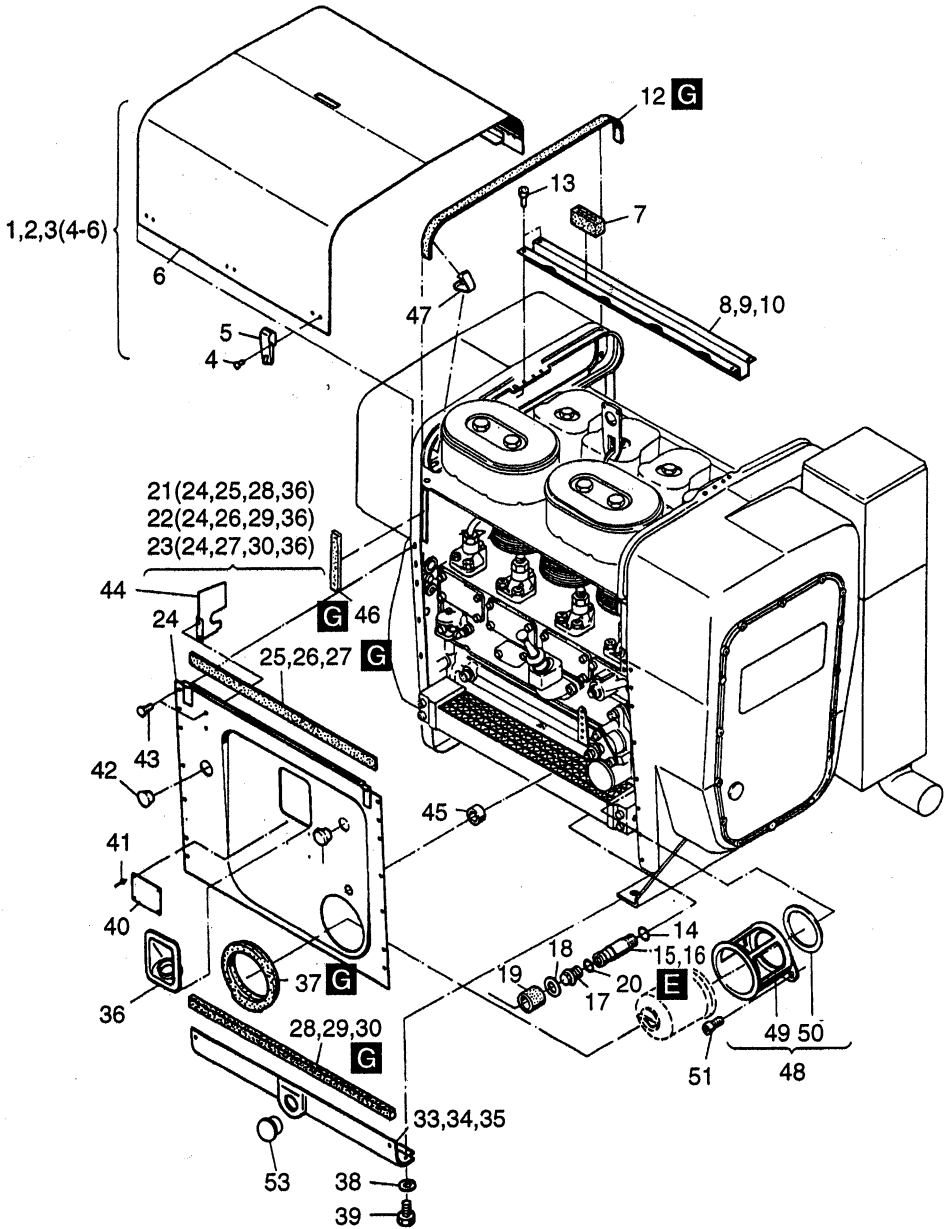

Fig.- No.	HATZ Ident-No.	Stück Qty.			P / W d / D	Bemerkungen Notes
		2 L..C	3 L..C	4 L..C/K		
36	03761401	1	1	1		
37	03594001	1	1	1		
38	50144500	3	4	5	6,4	DIN 125-St A3C
39	50025400	3	4	5	M 6 x 10	DIN 933-8.8
40	03225503	1	1	1		
41	40002500	4	4	4		
42	03769301	1	1	1	Ø 50 mm	
43	50289200	12	12	14	M 6 x 12	SB-8.8 A3D
44	03602000	-	-	1		
45	03579400	1	1	1		
46	03577200	2	2	2	125 mm	
47	03779900	4	4	4		
48	01247011	1	1	1		
49	-----	-	-	-		
50	04008400	1	1	1		
51	50385900	2	2	2	M 8 x 12	DIN 7984-8.8
52	40096000	1	1	1	F17	
53	50163101	1	1	1	F25	

A 01

Kraftstoff
Fuel
Carburant
Combustible
Combustibile

Tafel Nr.
Tabl. No.
Tavola N.

24

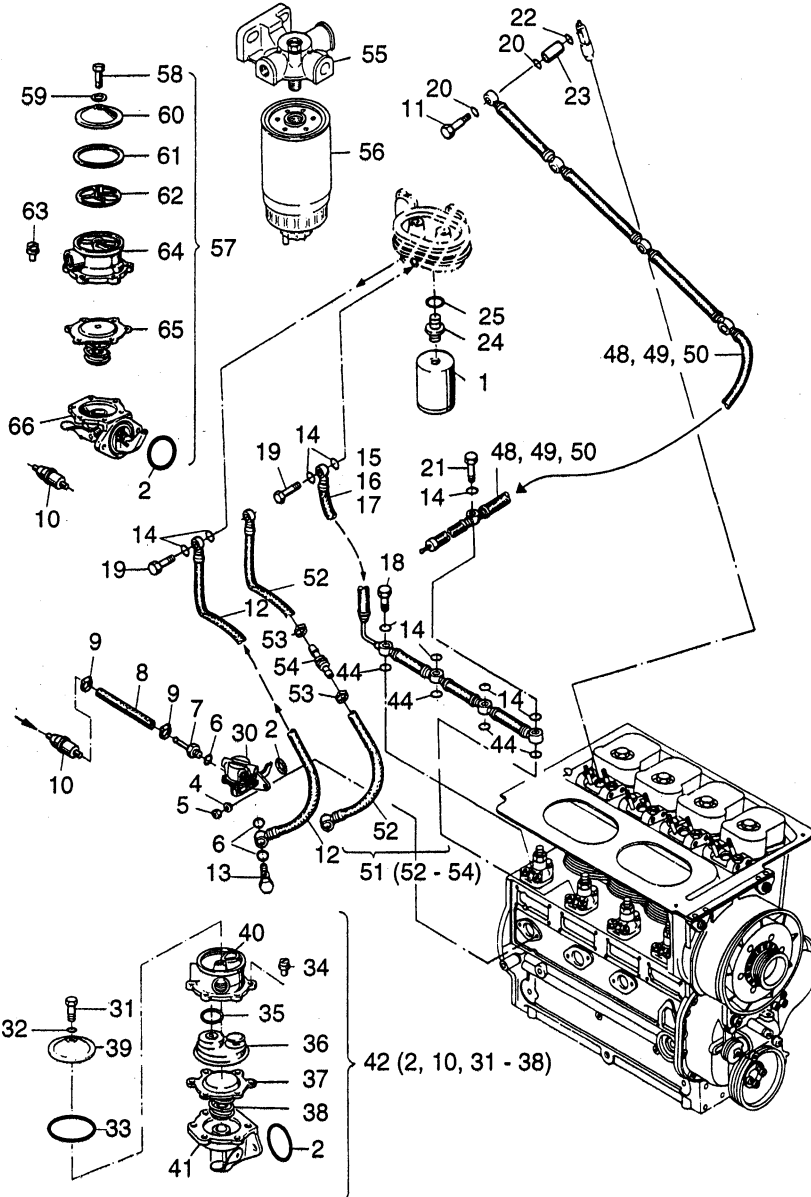

Fig.- No.	HATZ Ident-No.	Stück Qty.	P / W d / D	Bemerkungen Notes
		2 L ..C	3 L ..C	4 L ..C/K
1	50251500	1	1	1 W1
2	50129900	1	1	1 D1
3	-----	-	-	-
4	50081200	2	2	2
5	50144400	2	2	2
6	50001200	3	3	3 D4
7	03466800	1	1	1
8	03801200	1	1	1
9	40037300	2	2	2
10	50317000	1	1	1 W1
11	03460200	2	3	4
12	03573301	1	1	1
13	50006400	1	1	1
14	50001100	7	8	9 D13
15	03836500	1	-	-
16	03836600	-	1	-
17	03836700	-	-	1
18	03613400	1	2	3
18	04108700	1	2	3
19	50006300	2	2	2
20	50000900	4	6	8 d2,D8
21	03639700	1	1	-
21	04108800	1	1	-
21	03890600	-	-	1
22	50000800	2	3	4 d1
23	03573900	2	3	4
24	50253300	1	1	1
25	50001200	1	1	1 D4
26	-----	-	-	-
27	-----	-	-	-
28	-----	-	-	-
29	-----	-	-	-
30	01478902	1	1	1
31	-----	-	-	-
32	-----	-	-	-
33	50399500	1	1	1
34	-----	-	-	-

A 01 Kraftstoff
Fuel
Carburant
Combustible
Combustibile

Tafel Nr.
Tabl. No.
Tavola N.
24

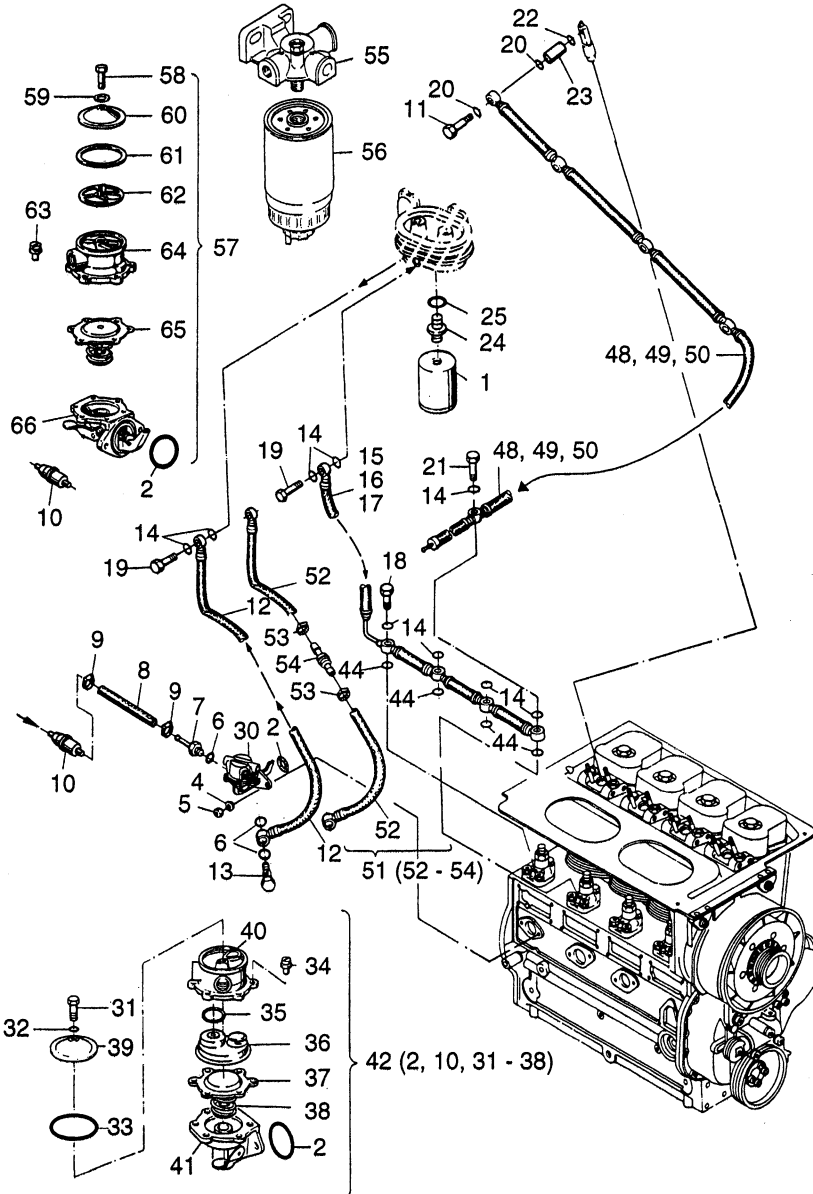

Fig.- No.	HATZ Ident-No.	Stück Qty.	P / W d / D	Bemerkungen Notes
		2 L..C	3 L..C	4 L..C/K
35	-----	-	-	-
36	-----	-	-	-
37	-----	-	-	-
38	-----	-	-	-
39	-----	-	-	-
40	-----	-	-	-
41	-----	-	-	-
42	01479001	1	1	1
				Reparatursatz, repair kit f. 01478901 – 01478902 FCM-IMSA
43	-----	-	-	-
44	03969400	2	3	4
45	-----	-	-	-
46	-----	-	-	-
47	-----	-	-	-
48	00802200	1	-	-
49	00802400	-	1	-
50	00802500	-	-	1
51	01191100	1	1	1
52	-----	-	-	-
53	40037300	2	2	2
54	50343400	1	1	1
55	50345600	1	1	1
56	50345700	1	1	1
57	01562700	1	1	1
58	-----	-	-	-
59	49018500	1	1	1
60	-----	-	-	-
61	49018400	1	1	1
62	49018300	1	1	1
63	49018100	6	6	6
64	-----	-	-	-
65	49018200	1	1	1
66	-----	-	-	-

A 02

Zyklon
Cyclon
Cyclone
Ciclon
Prefiltro a ciclone

Tafel Nr.
Tabl. No.
Tavola N.

25

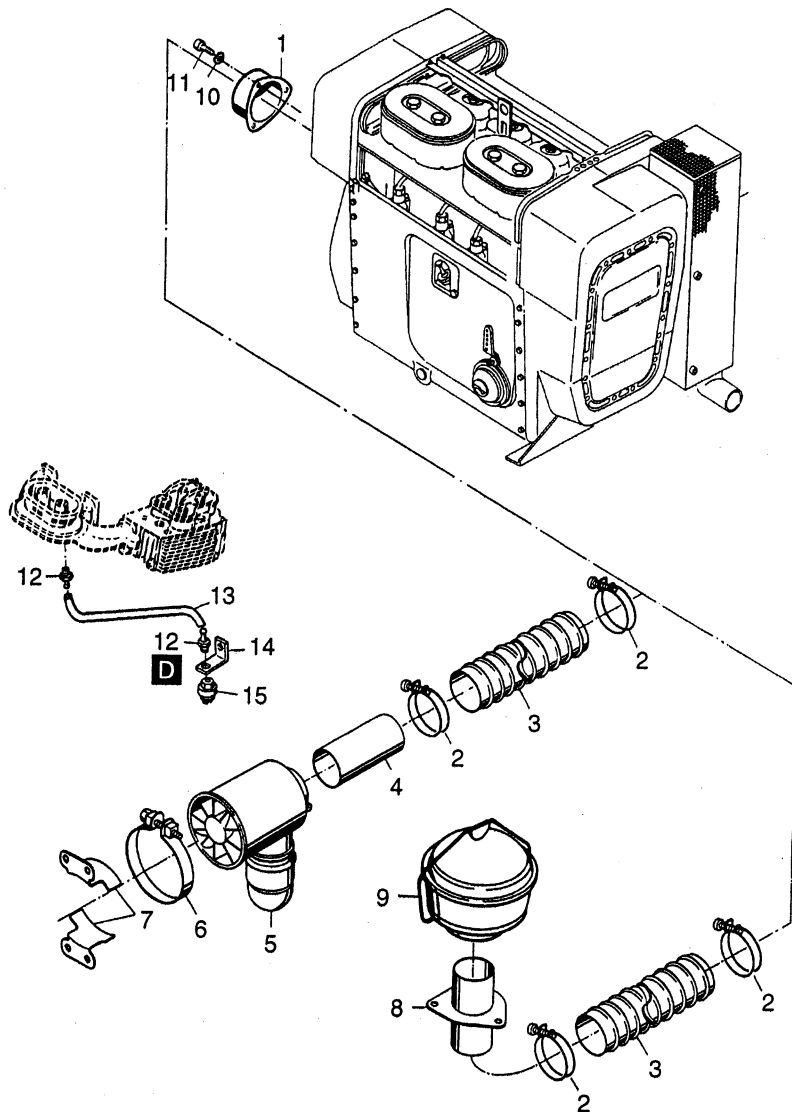

Fig.- No.	HATZ Ident-No.	Stück Qty.	P / W d / D	Bemerkungen Notes
2 .. 4 L ..C/K				
1	01027200	1		
2	50197300	2		64/73
3	03905300	1...4		1 m
4	03820500	1		
5	40035300	1		
6	40029100	1		
7	03820800	2		
8	01027100	1		
9	50196100	1		
10	50081200	3		A 6 DIN 137
11	50149100	3		M 6 x 12 DIN 912-8.8 A3C
12	50167700	2		
13	03481100	1		4,5 x 520
14	03693610	1		
15	50346300	1		mech.

A 03

Auspuff C / K
Exhaust C / K
Echappement C / K
Escape C / K
Scarico C / K

Tafel Nr.
Tabl. No.
Tavola N.

26

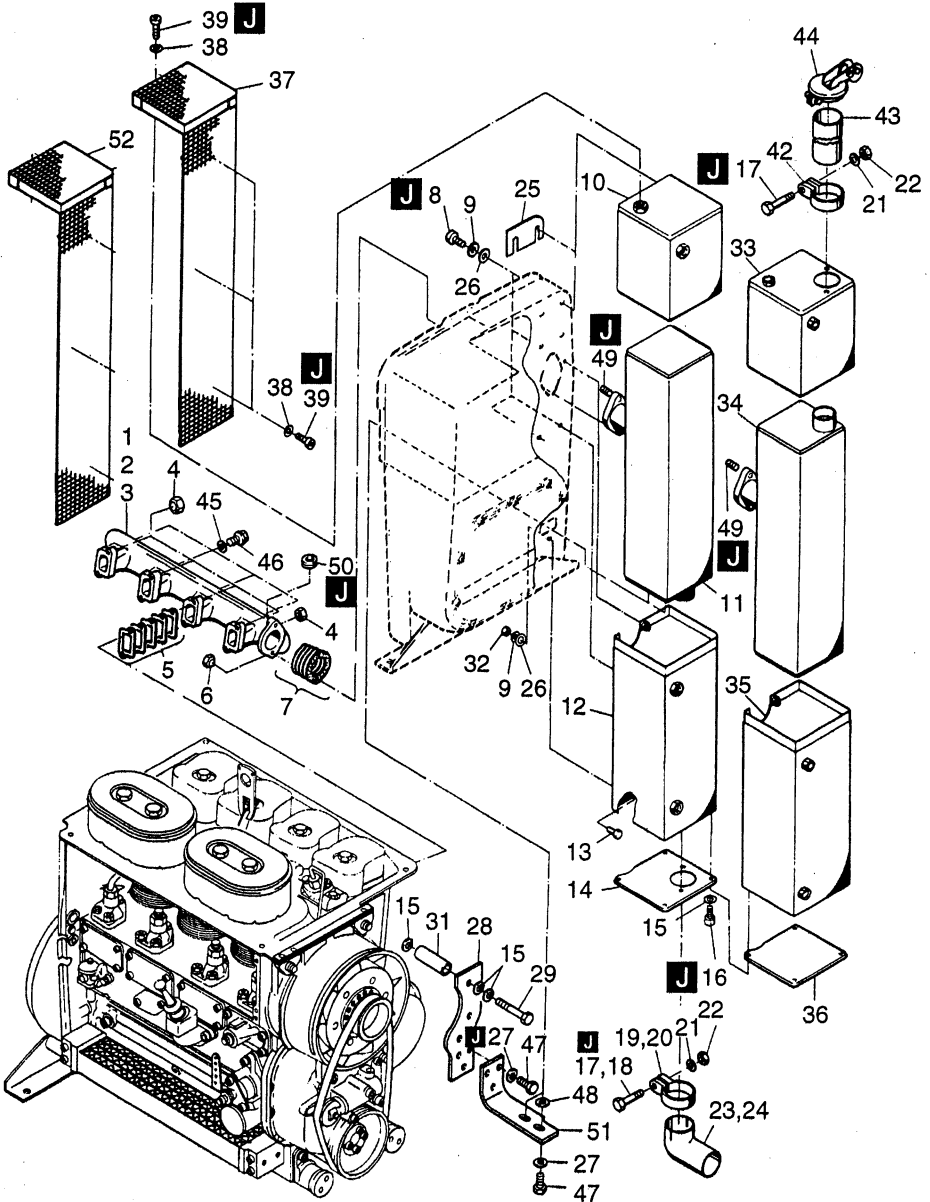

Fig.- No.	HATZ Ident-No.	Stück Qty.			P / W d / D	Bemerkungen Notes	
		2 L..C	3 L..C	4 L..C/K			
1	03770400	1	-	-			
2	03770500	-	1	-			
3	03768600	-	-	1			
4	50400700	4	6	8	P2	M 8	SW 12
5	01284501	2	3	4	d1		
6	40028600	2	2	2		M 10	SSN 440-8 Cu
7	01603700	1	1	1			
8	50255700	7	7	7		M 6 x 12	DIN 912 8.8 C4A
9	50002700	8	8	8		6	DIN 128
10	00902901	1	1	1			
11	03741903	1	1	-			
11	03829901	-	-	1			
12	00871801	1	1	1			
13	50025500	1	1	1		M 6 x 12	DIN 933-8.8
14	03877900	1	1	1			
15	50148100	13	13	13		8,4	DIN 125-St A3C
16	50138900	4	4	4		M 8 x 12	DIN 912-8.8
17	50249500	1	1	-		M 10 x 50	DIN 931-8.8 A3C
18	50249500	-	-	1		M 10 x 50	DIN 931-8.8 A3C
19	03877700	1	1	-		52,5	
20	03877800	-	-	1		58,5	
21	50145900	1	1	1		B 10,5	DIN 125-St A3C
22	40028600	1	1	1		SSN 440-8Cu	
23	03877500	1	1	-		52,5	
24	03877600	-	-	1			
25	03855400	0...4	0...4	0...4			
26	50144500	8	8	8		6,4	DIN 125-St A3C
27	50123000	5	5	5		8,4	DIN 7349
28	03958900	1	1	1			
29	50087900	3	3	3		M 8 x 70	DIN 931-8.8
30	-	-	-			
31	03538701	3	3	3			
32	50144400	1	1	1		M 6	DIN 934-8 A3C
33	01083000	1	1	1			
34	03883801	1	1	1			
35	00871801	1	1	1			

A 03
 Auspuff C / K
 Exhaust C / K
 Echappement C / K
 Escape C / K
 Scarico C / K

Tafel Nr.
 Tabl. No.
 Tavola N.
26

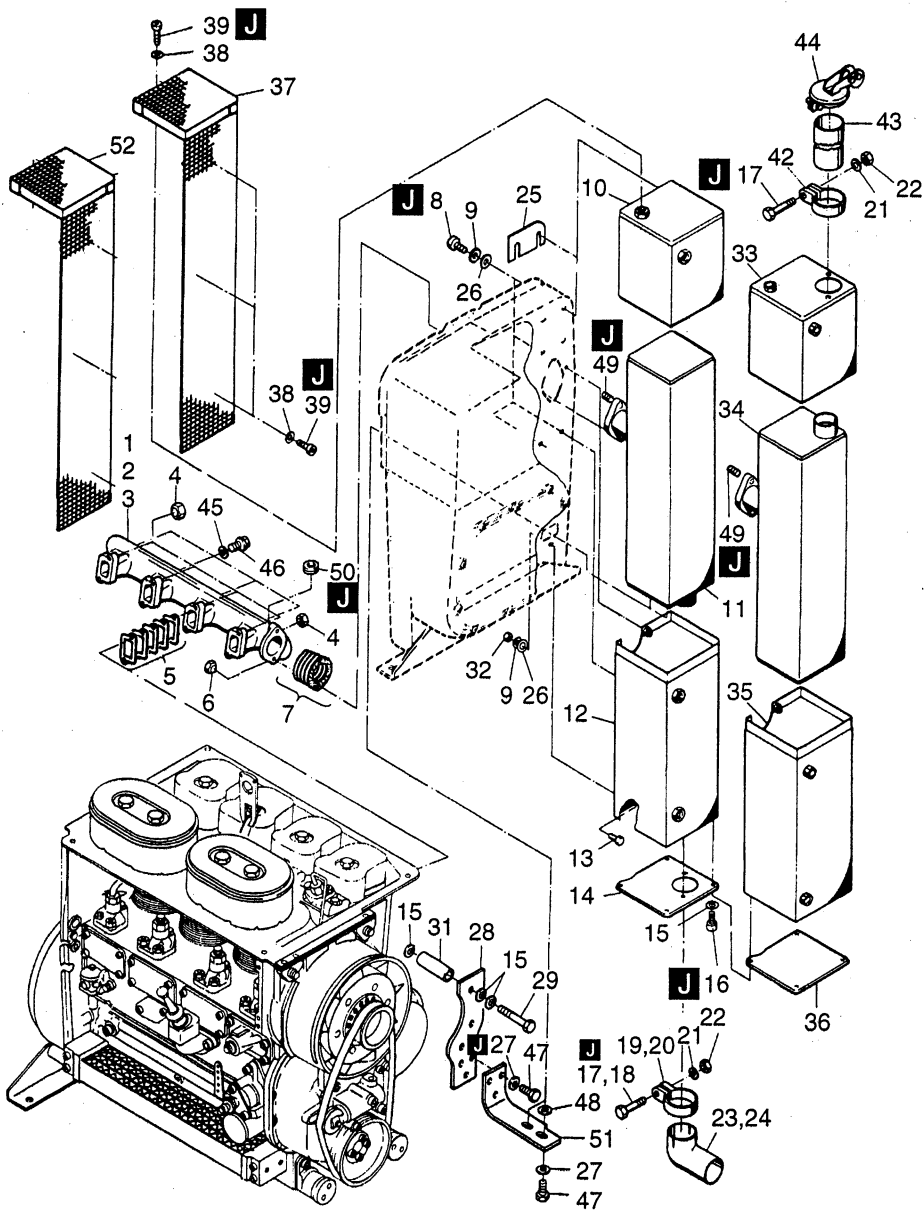

Fig.- No.	HATZ Ident-No.	Stück Qty.			P / W d / D	Bemerkungen Notes
		2 L..C	3 L..C	4 L..C/K		
36	03878000	1	1	1		
37	00849201	1	1	1		
38	50120000	7	7	7	A 6,4	DIN 9021-St Zn
39	50139000	7	7	7	M 6 x 10	DIN 912-8.8 C4P
40	-----	-	-	-		
41	-----	-	-	-		
42	03877700	1	1	1	52,5	
43	03889700	1	1	1		
44	50279700	1	1	1		
45	03228800	2	3	4		
46	50044700	2	3	4	R 1/4	DIN 910
47	50357400	5	5	5	M 8 x 25	DIN 933-8.8 C4P
48	03213100	0...6	0...6	0...6		
49	50040800	2	2	2	M 10 x 28	DIN 939-10.9
50	50278100	1	1	1	R 1/4	DIN 906-5.8
51	03959000	1	1	1		
52	03819200	1	1	1		

A 05

Starter, Generator
Starter, alternator
Demarreur, alternateur
Arrancador, alternador
Motorino avviamento, alternatore

Tafel Nr.
Tabl. No.
Tavola N.

27

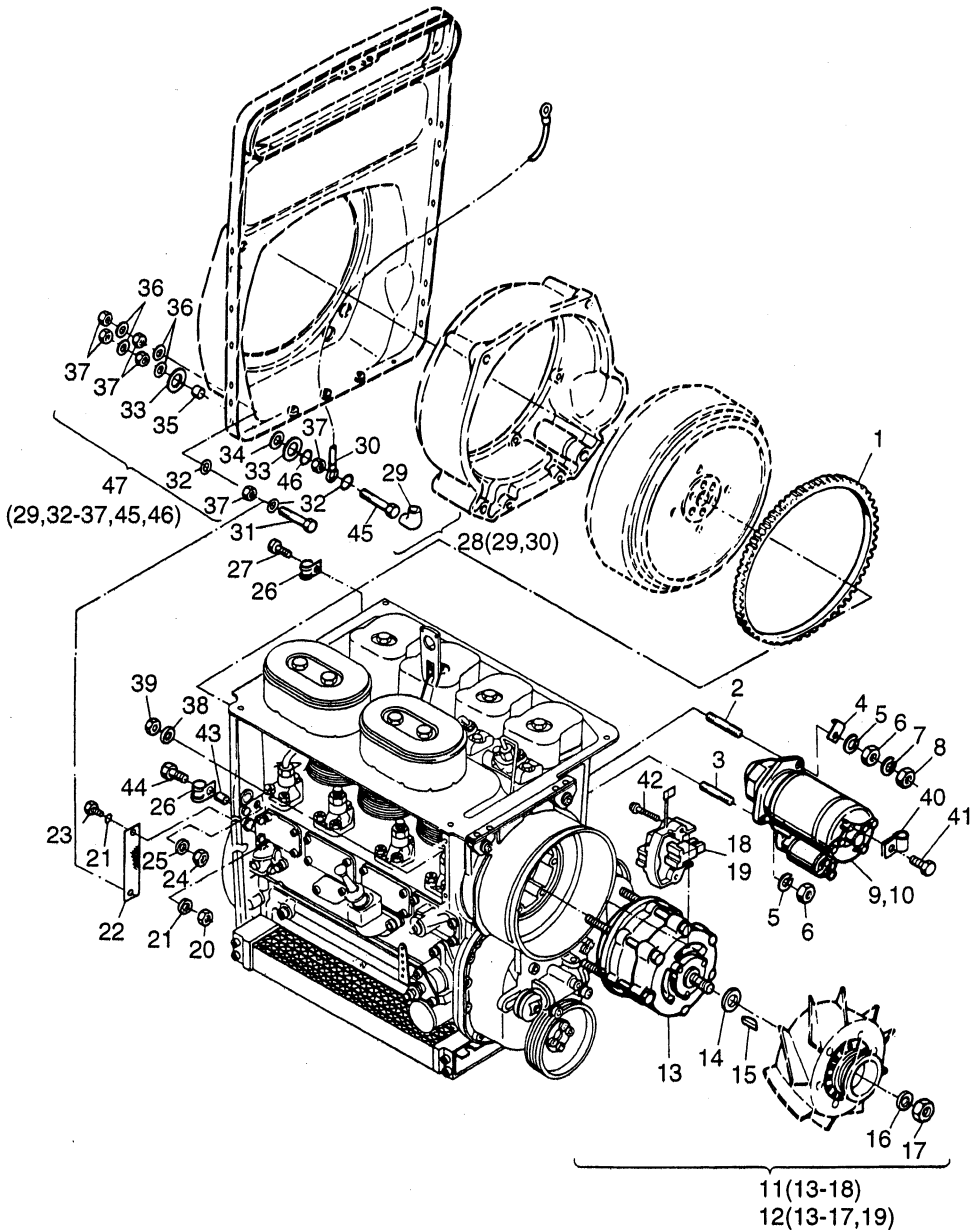

Fig.- No.	HATZ Ident-No.	Stück Qty.	P / W d / D	Bemerkungen Notes
2..4L..C/K				
1	03156101	1		
2	03286800	1		
3	50042300	1		M 12 x 25 DIN 939-5.6 A3C
4	03689610	1		
5	50003000	2	12	DIN 128
6	50023900	2	M 12	DIN 934-8
7	50063200	-	12	DIN 128 A3C
8	50063500	-	M 12	DIN 936-17 H
9	50183500	1	12 V	2,7 kW
10	50195400	1	24 V	4,0 kW
11	40121002	1	14 V	50 A
12	50164902	1	28 V	40 A 2 P
13	-----	-		
14	-----	-		
15	50017800	1	4 x 6,5	DIN 6888
16	-----	-		
17	49053600	1		
18	49053803	1	14 V	
19	49053903	1	28 V	
20	50148000	1	M 8	DIN 934-8 A3C
21	50148100	2	8,4	DIN 125-St A3C
22	03692800	1		
23	50098500	1	M 8 x 16	DIN 933-8.8 A3C
24	50144400	2	M 6	DIN 934-8 A3C
25	50081200	2	A 6	DIN 137 A3C
26	50158400	3		
27	50177100	2	M 6 x 16	DIN 933-8.8 A3C
28	00817300	1		
29	40026600	1		
30	00817300	1		
31	50275300	1	M 8 x 35	DIN 933-MS
32	50179900	4	J 8,2 Zn	DIN 6797
33	03814100	2		
34	50426800	1	J 10,5	DIN 6797 A3C
35	03814200	1		
36	50016800	4	8,4	DIN 125-MS

A 05

Starter, Generator
Starter, alternator
Demarreur, alternateur
Arrancador, alternador
Motorino avviamento, alternatore

Tafel Nr.
Tabl. No.
Tavola N.

27

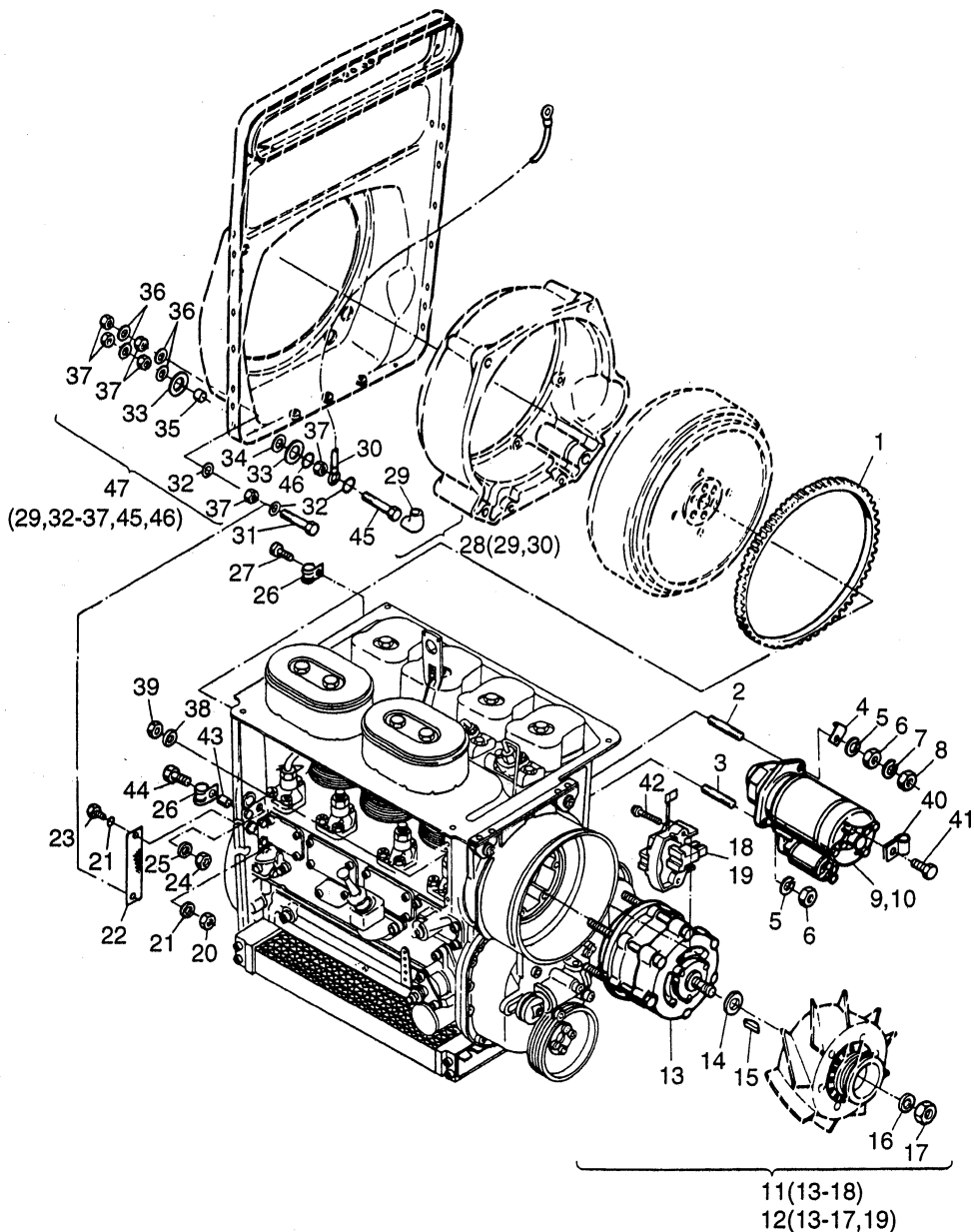

Fig.- No.	HATZ Ident-No.	Stück Qty.	P / W d / D	Bemerkungen Notes
2..4L..C/K				
37	50023000	6		M 8 DIN 934-MS
38	50081200	5		A 6 DIN 137 A3C
39	50144400	5		M 6 DIN 934-8 A3C
40	50158400	1		
41	50165500	1		M 6 x 12 DIN 933-8.8 A3C
42	-----	-		
43	03042700	1		7 x 12 x 20
44	50168700	1		M 6 x 35 DIN 931-8.8 A3C
45	50400300	1		M 8 x 40 DIN 933-MS
46	50426900	1		A 8,4 DIN 6798 A3C
47	01472900	1		

A 05

Armaturenkasten
Instrument box
Boitiere de bord
Cuadro de mando
Cruscotto

Tafel Nr.
Tabl. No.
Tavola N.

28

1 (3-18,20,23-26,28-41,43,45,46)

2 (3-18,20,23-25,27-40,42,44-46)

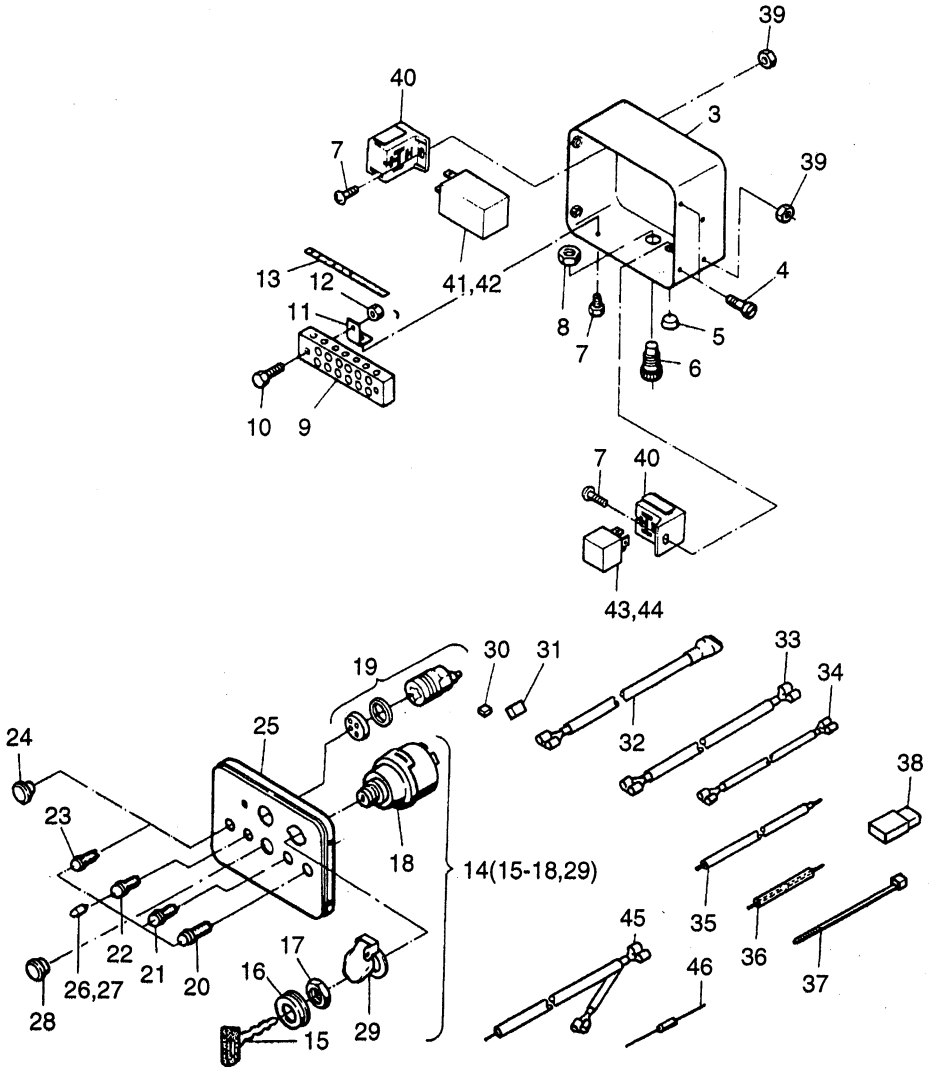

Fig.- No.	HATZ Ident-No.	Stück Qty.			P / W d / D	Bemerkungen Notes
		2 L..C	3 L..C	4 L..C/K		
1	00826204	1	1	1		12 V
2	00823604	1	1	1		24 V
3	00716311	1	1	1		
4	50289200	4	4	4		M 6 x 12 SB-8.8 A3C
5	50160800	2	2	2		
6	50159011	1	1	1		
7	50049300	4	4	4		M 5 x 10 DIN 7985-4.8 A3R
8	50159100	1	1	1		
9	50160700	1	1	1		
10	50158800	2	2	2		M 4 x 20 DIN 84-4.8 A3C
11	03666700	2	2	2		
12	50147100	2	2	2		M 4 DIN 934-8 A3C
13	03671701	1	1	1		
14	50276502	1	1	1		
15	50345300	1	1	1	P1	
16	-----	-	-	-		
17	-----	-	-	-		
18	-----	-	-	-		
19	40068600	1	1	1...2		4 L...: 12 V (2) 24 V (1)
20	50176500	1	1	1		BATT
21	50176600	1	1	1		OIL
22	50176400	1	1	1		TEMP
23	50182400	1	1	1		FILTER
24	40096000	0...2	0...2	0...2		F 17
25	03509211	1	1	1		
26	40009700	4	4	4		12 V 2 W
27	40009800	4	4	4		24 V 2 W
28	40091400	0...2	0...2	0...2		F 24
29	49050900	1	1	1		
30	50276600	1	1	1		4-P
31	50276700	1	1	1		6-P
32	00818203	1	1	1		
33	01089801	1	1	1		
34	01089901	1	1	1		
35	01090201	1	1	1		
36	01150101	1	1	1		

A 05 Armaturenkasten
 Instrument box
 Boitiere de bord
 Cuadro de mando
 Cruscotto

Tafel Nr.
 Tabl. No.
 Tavola N.

28

1 (3-18,20,23-26,28-41,43,45,46)
 2 (3-18,20,23-25,27-40,42,44-46)

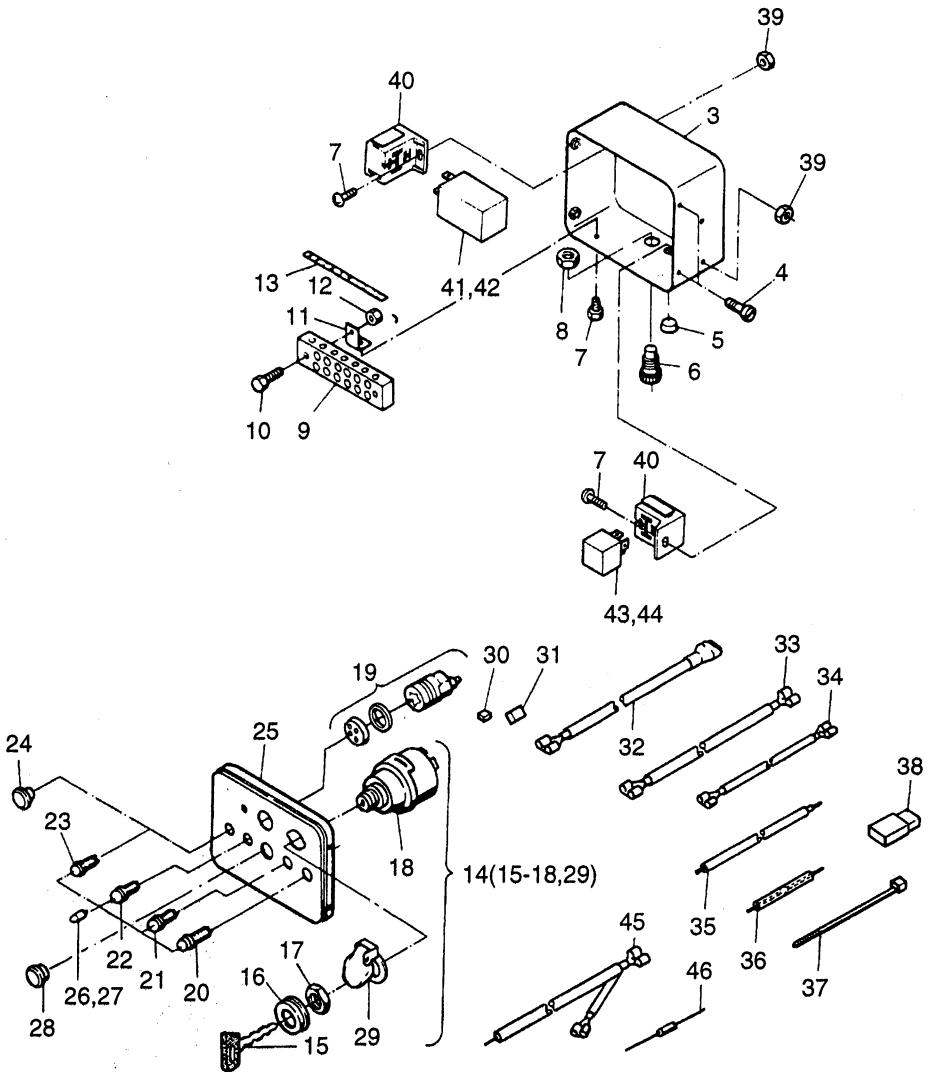

Fig.- No.	HATZ Ident-No.	Stück Qty.	P / W d / D	Bemerkungen Notes	
		2 L ..C	3 L ..C	4 L ..C/K	
37	50358400	3	3	3	
38	50190700	1	1	1	
39	40028200	2	2	2	
40	50276000	2	2	2	
41	50275802	1	1	1	12 V HATZ MSR
42	50275902	1	1	1	24 V HATZ MSR
43	50277701	1	1	1	12 V BOSCH
44	50277801	1	1	1	24 V BOSCH
45	01154901	1	1	1	
46	50344400	1	1	1	

A 05

Armaturen, Leitungen
Electric equipment, wirings
Equipement électrique, cable
Equipo eléctrico, cables
Equipaggiamento elettrico, cablaggio

Tafel Nr.
Tabl. No.
Tavola N.

29

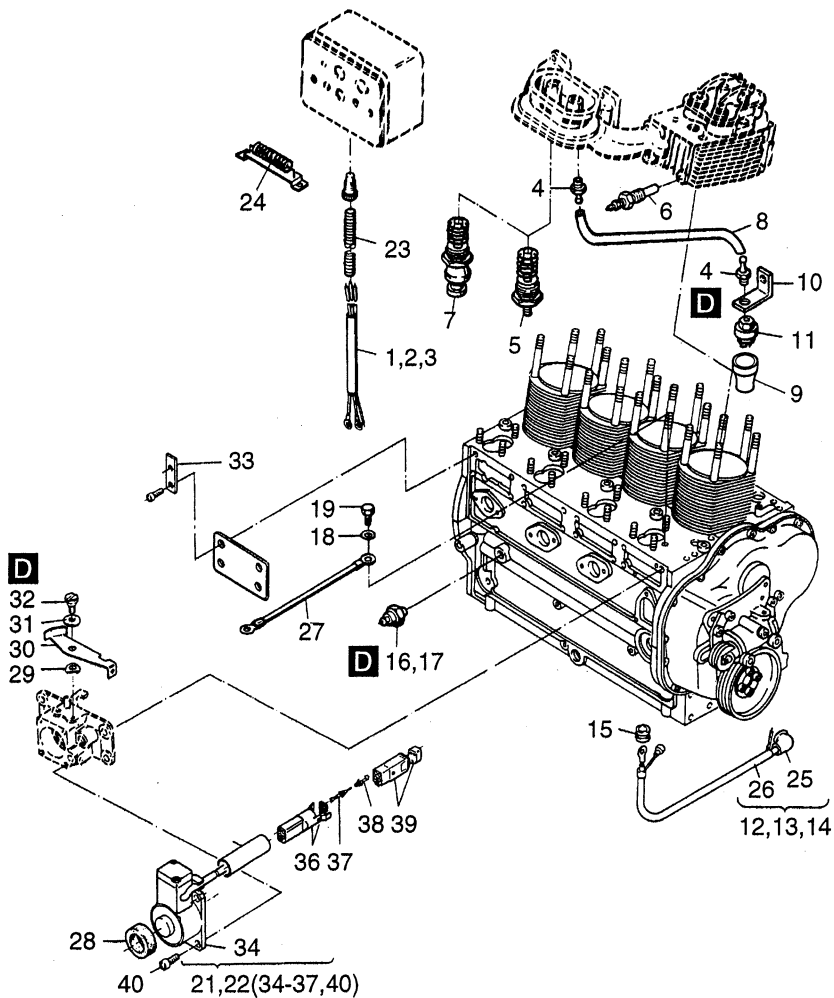

Fig.- No.	HATZ Ident-No.	Stück Qty.	P / W d / D	Bemerkungen Notes
		2 L ..C	3 L ..C	4 L ..C/K
1	01183300	1	-	-
2	01183500	-	1	-
3	01183700	-	-	1
4	50167700	2	2	2
5	50163900	1	1	1...2
6	50268600	1	1	1
7	50164100	-	-	1
8	03481100	1	1	1
9	50346100	1	1	1
10	03693610	1	1	1
11	50167600	1	1	1
12	01183200	1	-	-
13	01183400	-	1	-
14	01183600	-	-	1
15	50158500	1	1	1
16	40021300	1	1	1
17	50272200	-	-	1
18	50148100	1	1	1
19	50026700	1	1	1
20	-----	-	-	-
21	01541700	1	1	1
22	01541800	1	1	1
23	03668210	1	1	1
24	40088300	1	1	-
25	40026600	1	1	1
26	-----	-	-	-
27	00817100	1	1	1
28	03579800	1	1	1
29	50114300	1	1	1
30	03960200	1	1	1
31	50095100	1	1	1
32	50358600	1	1	1
33	03951800	2	3	4
34	-----	-	-	-
35	-----	-	-	-
36	50351200	1	1	1

184 G 4L...:12 V (2) 24 V (1)
TEMP

400 G 24 V

OIL
4 L .. C OIL >2300 min⁻¹
8,4 DIN 125-St A3C

M 8 x 16 DIN 933-8.8

12 V

24 V

2000 mm

24 V

6,4 DIN 7349

A 8 DIN 137
M 6 x 3 DIN 923-A3C

A 05

Armaturen, Leitungen
Electric equipment, wirings
Équipement électrique, cable
Equipo eléctrico, cables
Equipaggiamento elettrico, cablaggio

Tafel Nr.
Tabl. No.
Tavola N.

29

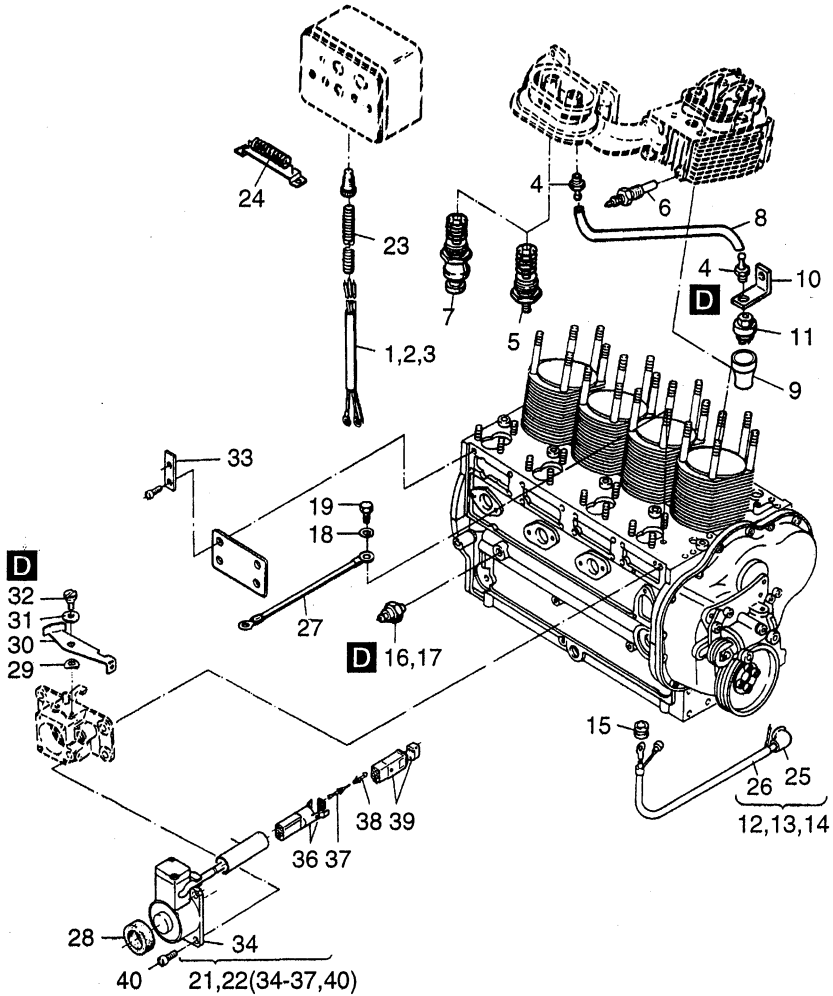

Fig.- No.	HATZ Ident-No.	Stück Qty.	P / W d / D	Bemerkungen Notes	
		2 L ..C	3 L ..C	4 L ..C/K	
37	50351000	3	3	3	
38	50350900	3	3	3	
39	50351100	1	1	1	
40	50434400	4	4	4	
					M 6 x 30 DIN 912-8.8 A3C Tuf.

A 06

Motorfüße
Engine brackets
Pieds moteur
Soportes del mot.
Staffe supp. mot.

A 15

Anschlußgeh.
Interm. housing
Bride raccord
Caja de con.
Flangia accopp.

Tafel Nr.
Tabl. No.
Tavola N.

30

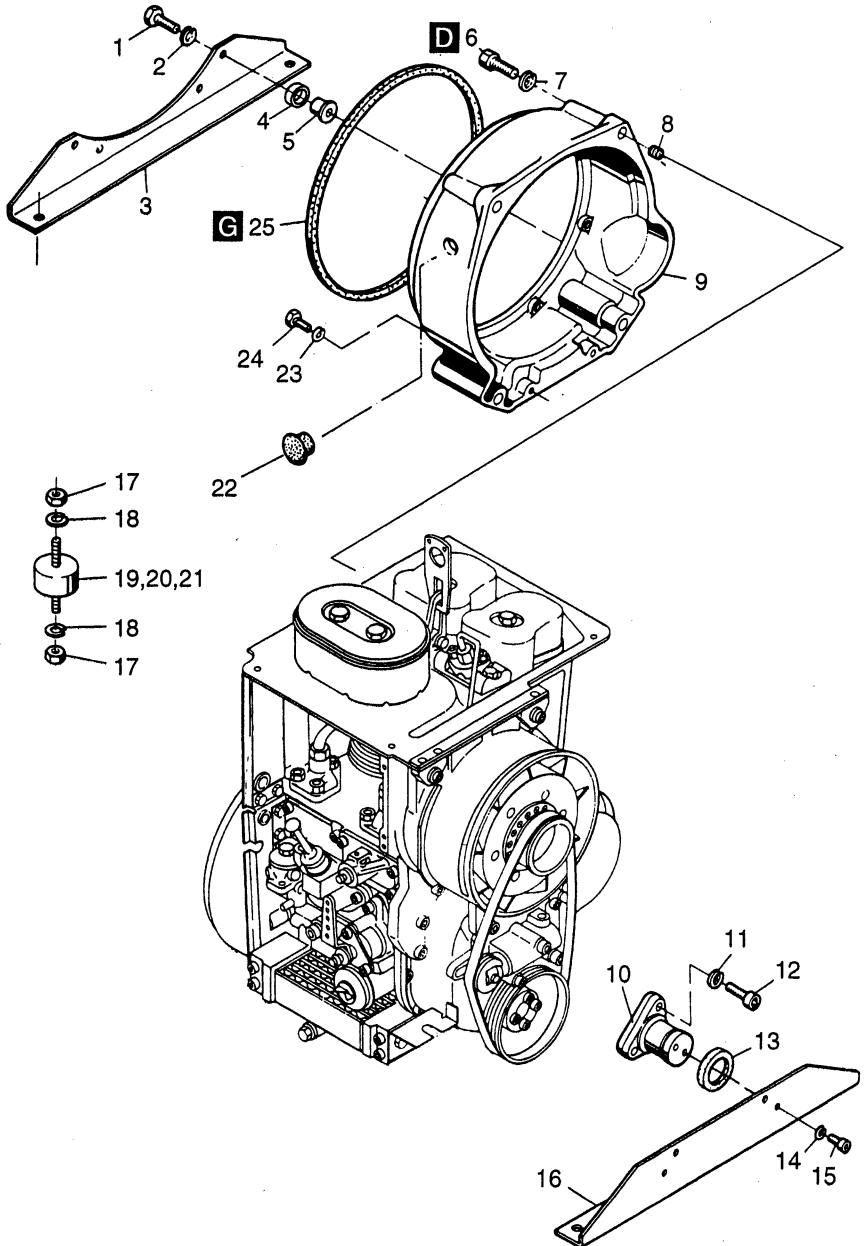

Fig.- No.	HATZ Ident-No.	Stück Qty.	P / W d / D	Bemerkungen Notes
2..4L..C/K				
1	50259300	4		M 12x 110 DIN 931-8.8 A3C
2	50063200	4		12 DIN 128 A3C
3	03878700	1		
4	03579800	4		
5	03579100	4		
6	50137300	4		M14x1,5x50DIN 960-8.8
7	50003100	4		14 DIN 128
8	50137400	4		18 x 18 DIN 7346
9	03575903	1		SAE 5
10	00739301	2		
11	03469300	4		12,5 x 22 x 3
12	50073000	4		M 12 x 40 DIN 912-12.9
13	03579900	2		
14	50135600	4		10 DIN 128 A3C
15	50136500	4		M 10 x 20 DIN 913-8.8 A3C
16	03878901	1		
17	50145800	8		M 10 DIN 934-8 A3C
18	50135600	8		10 DIN 128 A3C
19	50260100	4		40 SH 7
20	50260200	4		55 SH 8
21	50260300	4		65 SH 9
22	50237600	1		F 19
23	50002900	2		10 DIN 128
24	50029600	2		M 10 x 45 DIN 933-8.8
25	03592901	1		

A 07

Ölkühler, Ölwanne
Oil cooler, oil sump
Radiateur d'huile, carter d'huile
Radiador de aceite, carter de aceite
Radiator olio, coppa olio

Tafel Nr.
Tabl. No.
Tavola N.

31

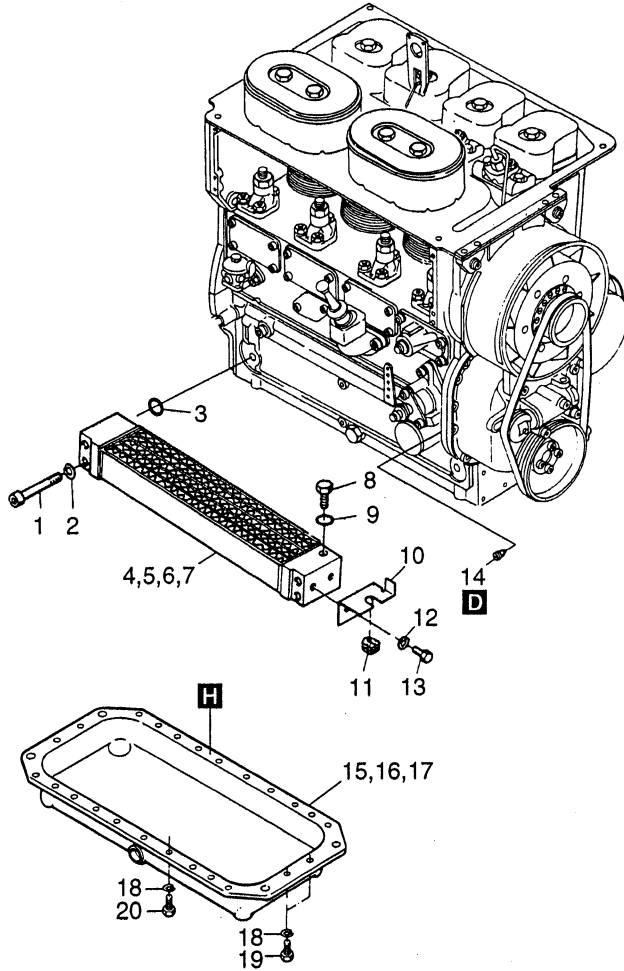

Fig.- No.	HATZ Ident-No.	Stück Qty.			P / W d / D	Bemerkungen Notes
		2 L..C	3 L..C	4 L..C/K		
1	50204100	4	2	4		M 8 x 95 DIN 6912-8.8
2	50003500	4	4	4		B8 DIN 137
3	50130400	2	2	2	D2	16,3 x 2,4
4	03647801	1	-	-		
5	03647901	-	1	-		
6	03648001	-	-	1		4 L ..C . .. 2300 min ⁻¹
7	03761501	-	-	1		4 L ..C > 2300 min ⁻¹
8	50137900	1	1	1		M 8 x 1 DIN 7604
9	50000900	1	1	1	D4	A 8 x 11,5 DIN 7603-Cu
10	03620101	1	1	1		
11	03568900	1	1	1		
12	50081200	2	2	2		A6 DIN 137
13	50025500	2	2	2		M 6 x 12 DIN 933-8.8
14	03465700	1	1	1		
15	00917500	1	-	-		s. Taf., Tabl. 20
16	00917600	-	1	-		} Pos. 33, 34, 35
17	00917701	-	-	1		
18	50002800	12	18	24		8 DIN 128
19	50279300	4	4	-		M 8 x 16 DIN 933-8.8 verb.Pl.
20	50026700	8	14	24		M 8 x 16 DIN 933-8.8

A 16

Elast. Kupplung
Flexible coupling
Accouplém. elastic
Acoplamiento elast.
Giunto elastico

A 18

Steuerdeckel für Hydraulik
Timing cover hydr.
Couvercle pour hydr.
Tapa de mando p. hidr.
Coperchio p. pompa idraulica

Tafel Nr.
Tabl. No.
Tavola N.

32

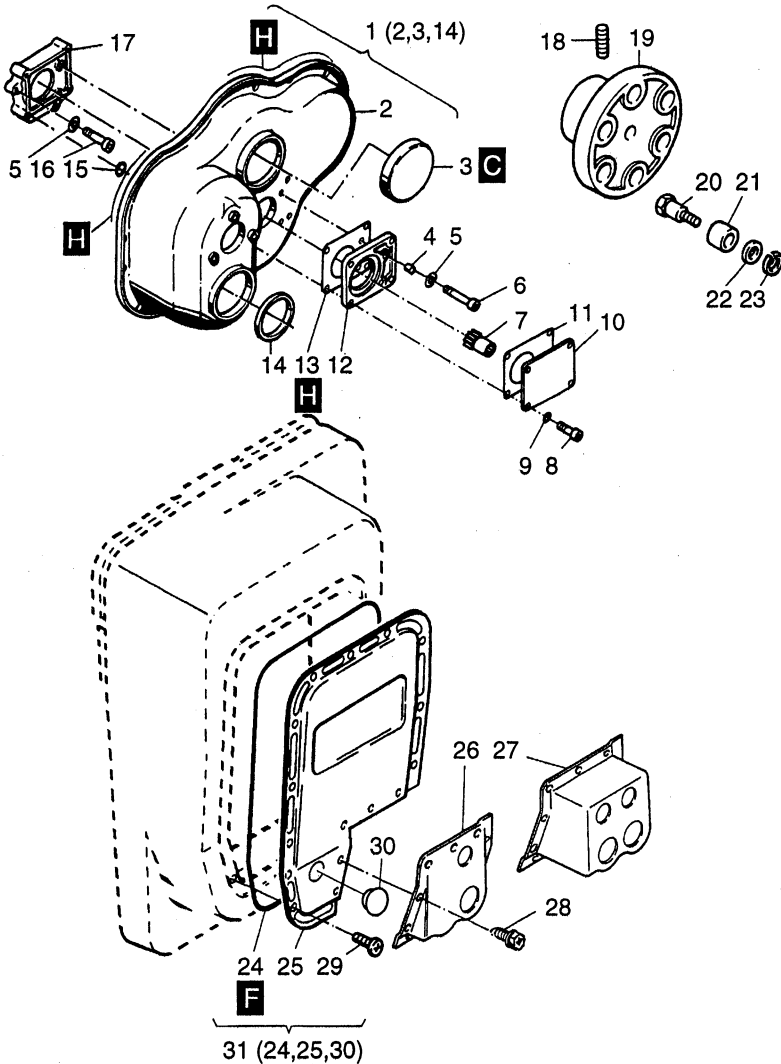

Fig.- No.	HATZ Ident-No.	Stück Qty.	P / W d / D	Bemerkungen Notes
2..4L..C/K				
1	00993501	1		
2	-----	-		
3	50126500	1		
4	50262000	2	10 x 10	DIN 7346
5	50002800	4	8	DIN 128
6	50258100	2	M 8 x 60	DIN 6912-8.8
7	01062300	1		
8	50268800	4	M 8 x 30	DIN 912-8.8
9	50162900	4	A 8 x 14	DIN 7603-Cu
10	03761600	1		
11	03568000	1		
12	03555011	1		
13	03754400	1		
14	50129100	1		
15	40022300	2	8 x 12 x 2	
16	50052500	2	M 8 x 40	DIN 912-8.8
17	03754300	1		
18	50004600	1	M 8 x 15	DIN 916-45H
19	03040500	1		
20	03046900	6		
21	03151000	6		
22	03079000	6	20,3 x 26,9 x 4	
23	50061600	6	12	DIN 7980
24	03847700	1	„C“	1260 mm
25	-----		„C“	
26	03842801	1	„C“	
27	03842700	1	„C“	
28	50335600	10	M 6 x 16	KZ1-8.8 A3D
29	50289200	12	M 6 x 12	KZ1-8.8 A3D
30	03769301	1		
31	01506400	1		

Serien-Nr.-Änderungen
Serial-code modification list
Modification des Nos de serien
Modificación de los Nos de serie
Modifica dei codici

Bildtafel	Pos. No.	Bestell-Nr.	Stück	Bildtafel	Pos. No.	Bestell-Nr.	Stück	
Table	Fig. No.	Ordering No.	Qty.	Table	Fig. No.	Ordering No.	Qty.	IMT
Planche	Fig. No.	No. référence	Qté.	Planche	Fig. No.	No. référence	Qté.	No.
Tabla	Fig. No.	No. de pedido	Cant.	Tabla	Fig. No.	No. de pedido	Cant.	
Tavola	Rif.	Codice	Q.tà	Tavola	Rif.	Codice	Q.tà	

2 L 40.18				2 L 40.19			89.487	
2 L 40.19				2 L 40.20			89.488	
2 L 40.20				2 L 40.21			92.513	
2 L 40.21				2 L 40.22			98.582	
3 L 40.17				3 L 40.18			89.487	
3 L 40.18				3 L 40.19			89.488	
3 L 40.19				3 L 40.20			90.503	
3 L 40.20				3 L 40.21			92.513	
3 L 40.21				3 L 40.22			98.582	
4 L 40.17				4 L 40.18			89.487	
4 L 40.18				4 L 40.19			89.488	
4 L 40.19				4 L 40.20			92.513	
4 L 40.20				4 L 40.21			98.582	
2 L 41.10				2 L 41.11			98.578	
2 L 41.11				2 L 41.12			98.582	
3 L 41.10				3 L 41.11			98.578	
3 L 41.11				3 L 41.12			98.582	
4 L 41.10				4 L 41.11			98.578	
4 L 41.11				4 L 41.12			98.582	



MOTORENFABRIK HATZ • D-94099 Ruhstorf • Germany
Tel.: 0 85 31 / 319-0 • Telex: 57260 • Telefax: 0 85 31 / 31 94 18
eMail: hatz.marketing@t-online.de • <http://www.hatz.com>

434 500 04 - 11.98 - 5

Printed in Germany

DM 3.50