

**HATZ**  
DIESEL

Motorenfabrik HATZ GmbH & Co KG  
D-8399 Ruhstorf a. d. Rott  
Tel.: 08531/319-1, Telex: 57260, Telefax: 08531/32716

Druck: Kröner, 34/492 - 4.88 - 3.  
Printed in West-Germany

Schutzgebühr DM 3.-  
Protection tax  
Taxe de protection  
Derecho de protección

Ersatzteil-Liste  
Spare parts list  
Liste des pièces de rechange  
Lista de recambios

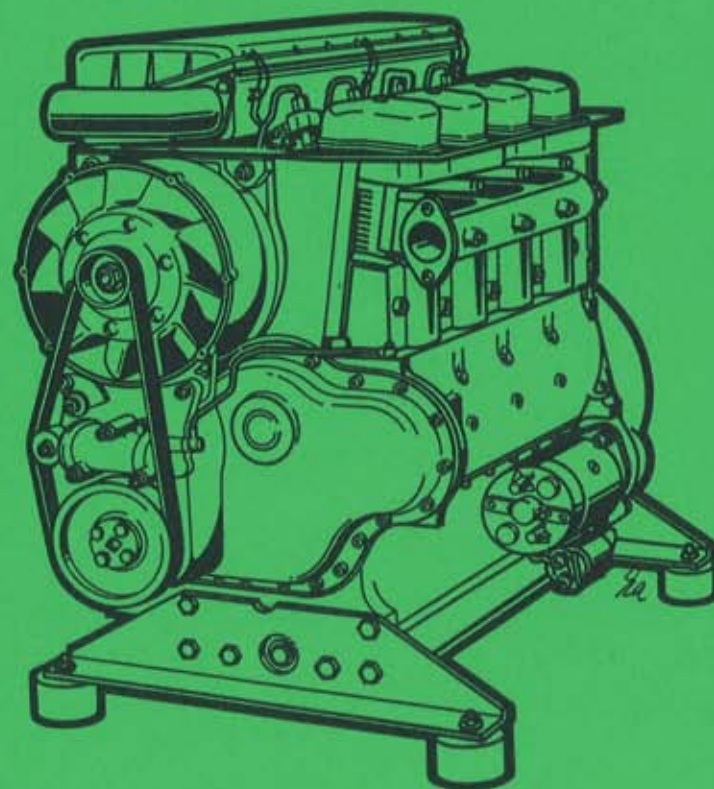

2...4 M 31  
2...4 M 40

No. 2 M 31.11  
No. 3 M 31.11  
No. 4 M 31.11

No. 2 M 40.15  
No. 3 M 40.15  
No. 4 M 40.15

**HATZ**  
DIESEL

WICHTIG – Bitte Daten eintragen  
IMPORTANT – Compléter les données

IMPORTANT – Please enter data  
IMPORTANTE – Favor completar datos

1.

Bitte hier **Type, Motornummer** und **Drehzahl** (siehe Motor-Typenschild) eintragen.

Enter here **type, engine no.** and **rpm.** (see engine type-plate).

Indiquer ici le **type, N° de moteur** et **régime** (voir plaque signalétique).

Insertar aquí **tipo- N° motor** y **r.p.m.** (vea placa del motor).

MOTORENFABRIK HATZ GmbH & Co. KG  
D-8399 RUHSTORF/ROTT

TYP	KENNZ.		
MOTOR/FABRIK NO.		ABE/AUSE	
MIN-1	NH	PV	CM <sup>3</sup>

**HATZ**  
**DIESEL**  
MADE IN GERMANY (FED. REP)

1

2.

Bitte **Ersatzteillistennummer** (siehe Titelseite) gemäß Type ankreuzen, z. B. Typ 4 M 31:

4 M 31.11

**Mark spare parts list no.** (see title-page) acc. to type, e.g. for type 4M31:

4 M 31.11

Cocher le **N° de liste de pièces de rechange** (voir: couverture) selon type, par. ex. 4 M 31:

4 M 31.11

Marcar **N° lista de recambios** (ver: frontispició) de acuerdo aipo, ejemplo tipo 4 M 31:

4 M 31.11

Ersatzteilliste Nr.

Spare parts list no.

Liste des pièces de rechange no.

Lista de recambios no.

2M31.11  3M31.11  4M31.11

2M40.15  3M40.15  4M40.15

2

3.

Bitte tragen Sie hier die **Anschrift** Ihrer nächsten HATZ-Servicestelle ein.

Insert here **address** of your next HATZ Service station.

Indiquer ici l'**adresse** de votre stationservice HATZ la plus proche.

Insertar aquí **dirección** de servicio HATZ más cercano.

HATZ-Service

3

MOTORENFABRIK HATZ  
GmbH & Co. KG  
D-8399 RUHSTORF a. d. ROTT  
Federal Republic of Germany  
☎ (085 31) 319-1  5 7260

## Angaben bei Ersatzteilbestellungen:

## Particulars for spare parts orders:

Zur richtigen und schnellen Belieferung mit Ersatzteilen sind folgende Angaben erforderlich:

The following information is needed to ensure correct and prompt supply of spare parts:

1. **Type, Motornummer und Drehzahl** des Motors, für den das Ersatzteil benötigt wird: siehe Angaben auf Seite 1, Feld 1.
2. **Nummer der Ersatzteilliste**, aus der die Bestellnummer herausgelesen wurde: siehe Seite 1, Feld 2.
3. **Stückzahl und Bestell-Nr.** des gewünschten Ersatzteils.
4. Gewünschte **Versandart**, z. B. Post, Luftfracht, Express.
5. Genaue **Versandadresse**, wenn erforderlich mit Post- u. Bahnstation.

1. **Engine type, engine number and r.p.m.** of the engine for which you need the spare part.  
See particulars on page 1, field 1.
2. **Number of spare parts list** from which you took the ordering no., see page 1, field 2.
3. **Quantity and ordering no.** of requested spare part.
4. Requested **mode of dispatch**, e. g. surface/airmail, airfreight, express.
5. Exact **shipping address**, if necessary indicate local post office and/or railway station.

### Bestellbeispiel:

Für Motortype: 4 M 31 - 154 b  
Motornummer: 8611881212  
min<sup>-1</sup>: 3000/60

aus Ersatzteil-Liste 4 M 31.11

folgende Teile:

Stück	Bestell-Nr.
2	500 526 00
8	500 812 00

per Postexpress an ...

### Die Ersatzteilbestellung richten Sie bitte an:

— die nächste HATZ-Servicestelle, Anschrift siehe Seite 1, Feld 3 oder separates Servicestellenverzeichnis

— oder an die

Motorenfabrik Hatz GmbH & Co. KG  
D-8399 Ruhstorf a. d. Rott  
Federal Republic of Germany  
☎ (0 85 31) 319-1 — ☎ 57260

### Example for your order:

For engine type: 4 M 31 - 154 b  
Engine number: 8611881212  
R. p. m.: 3000/60

Spare parts list no. 4 M 31.11

The following parts:

Qty.	ordering-no.
2	500 526 00
8	500 812 00

to be mailed, express, to ...

### Please address your spare parts order to:

— your nearest HATZ service station, address see page 1, field 3 or separate HATZ-service-list.

— or to

Motorenfabrik Hatz GmbH & Co. KG  
D-8399 Ruhstorf a. d. Rott  
Federal Republic of Germany  
☎ (0 85 31) 319-1 — ☎ 57260

## Données à indiquer lors de vos commandes de pièces détachées:

Pour nous permettre de livrer vos pièces rapidement et correctement, nous avons besoin des données suivantes:

1. **Type, No. et régime du moteur** pour lequel vous avez besoin de pièces: voir données page 1, carré 1.
2. **No de la liste de pièces de rechange** dans laquelle figure le No. de commande: voir page 1, carré 2.
3. **Quantité et No. de commande** de la pièce souhaitée.
4. **Mode d'expédition** souhaitée: par ex. par poste, frêt aérien, exprès.
5. **Adresse exacte de destination** et, lorsque ceci est nécessaire, le nom de la poste ou de la gare, ou aéroport.

### Exemple:

Pour type de moteur: 4 M31 - 154b  
No. moteur: 8611881212  
Régime: 3000/60

Liste de pièces de rechange: 4 M31.11

Les pièces suivantes:

Qté	No. commande
2	500 526 00
8	500 812 00

par poste exprès à ...

### Les commandes de pièces détachées sont à adresser à:

— votre station-service HATZ la plus proche, voir adresse page 1, carré 3 ou liste de service séparée.

— ou

Motorenfabrik Hatz GmbH & Co. KG  
D-8399 Ruhstorf a. d. Rott  
République Fédérale d'Allemagne  
☎ (08531) 319-1 — ☎ 57260

## Datos para pedidos de recambios:

Para recibir sus recambios en forma rápida y correcta necesitamos las siguientes informaciones:

1. **Tipo, número del motor y revoluciones:**  
ver detalles en página 1, posición 1.
2. **Número de la lista de recambios** de la cual se ha obtenido el número de pedido: ver página 1, posición 2.
3. **Cantidad y número de pedido del recambio deseado.**
4. Tipo de **despacho deseado:** por ej. correo, flete aéreo, expreso etc.
5. **Dirección** exacta, si necesario indicar la oficina de correo, la estación ferrocarril o aeropuerto.

### Ejemplo de pedido:

Para motor tipo: 4 M31 - 154b  
Número de motor: 8611881212  
R. P. M.: 3000/60

De la lista de recambios: 4 M31.11

Siguientes recambios:

Cantidad	Número de pedido
8	500 812 00
2	500 526 00

Por correo expreso a ...

### El pedido de recambios favor dirigirlo a:

— Alservicio HATZ más cercano, dirección verla en página 1, posición 3 o en el índice separado de direcciones de servicio.

— Alternativa a:

Motorenfabrik Hatz GmbH & Co. KG  
D-8399 Ruhstorf a. d. Rott  
República Federal de Alemania  
☎ (08531) 319-1 — ☎ 57260

	<b>Inhaltsverzeichnis:</b>	<b>Index:</b>	<b>Tafel No. Table No.</b>
<b>M . . .</b>	<b>Grundmotor</b>	<b>Basic engine</b>	
00, 34	Ersatzteilsätze, Zubehör	Spare part kits, accessories	01
01	Kurbelgehäuse	Crankcase	02+03
02, 03	Kurbelwelle	Crankshaft	04
04	Nockenw., Regler, Spritzversteller	Camshaft, governor, timer	05
04	Drehzahlverstellung	Speed control	06
05, 06	Kolben, Pleuelstange, Zylinder	Piston, conrod, cylinder	07
07	Zylinderkopf	Cylinder head	08
09, 10	Stoßstange, Ölpumpe	Pushrod, oil pump	09
11	Steuerdeckel	Timing cover	10
12	Startfüllung	Extra fuel device	11
13	Gebälse	Blower	12
14	Einspritzausrüstung	Injection equipment	13
16 - 20	Riemenscheibe, Schwungrad, Hydr. Abstellvorrichtung	Pulley, flywheel, hydr. belt tensioner	14
22, 27	Luftfilter, Luftansaugrohr	Air filter, air intake manifold	15
26	Luftführung	Air ducting	16, 17, 18
<b>A . . .</b>	<b>Zusatzausrüstung</b>	<b>Equipments</b>	
01	Förderpumpe	Fuel feed pump	19
01	Kraftstoffbehälter	Fuel tank	20
02	Zyklon	Cyclon	21
03	Auspuff	Exhaust	22
04	Andrehkurbel, Andrehvorr.	Starting handle, starting device	23
04	Dekompressionsautomatik	Autom. decompression	24
04	Startfreigabe	Start release device	25
05	Starter, Generator	Starter, alternator	26
05, 10	Armaturenkasten	Instrument box	27
05, 10	Armaturen, Leitungen	El. equipment, wirings	28
06	Motorfüße, Schwingungsdämpfer	Engine brackets, vibration damper	29
07	Ölkühler, Ölwanne	Oil cooler, oil sump	30
08	Anbaut. Zuluftschtach, Abluftschtach	Air duct. adaption, air ducting	31
12, 15	Keilriemenschutz, Anschlußgehäuse	V-belt guard, intermediate housing	32
18	Steuerdeckel f. Hydraulik	Timing cover hydr.	33
	<b>Serien-Nr.-Änderungen</b>	<b>Serial-code modification list</b>	<b>Seite/Page</b>
			92

**Sommaire:**

**Indice:**

<b>M...</b>	<b>Moteur de base</b>	<b>Motor de base</b>	
00, 34	Jeux de pièces de rechange, accessoires	Juegos de pieza de recambios, accesorios	01
01	Carter moteur	Caja cigueñal	02+03
02, 03	Vilebrequin	Cigueñal	04
04	Arbre à cames, regulateur, variateur d'avance	Arbol de levas, regulador, variador de avance	05
04	Reglage regime	Ajuste de revoluciones	06
05, 06	Piston, bielle, cylindre	Émbolo, biela, cilindro	07
07	Culasse	Culata	08
09, 10	Tige de culbuteur, pompe a huile	Varilla de balancín, bomba de aceite	09
11	Couvercle distribution	Tapa de mando	10
12	Sucharge	Sobre aliment.-arranque	11
13	Soufflerie	Ventilador	12
14	Équipement d'injection	Equipo de inyección	13
16 - 20	Poulie, volant, tendeur hydr.	Polea, volante, tensor hidráulico	14
22, 27	Filtre à air, collecteur d'admission	Filtro de aire, tubo de aspiracion	15
26	Carter ventilation	Conducción de aire	16, 17, 18
<b>A...</b>	<b>Accessoires</b>	<b>Equipos</b>	
01	Pompe alimentation	Bomba de alimentac.	19
01	Reservoir à carburant	Depósito combustible	20
02	Cyclone	Ciclon	21
03	Echappement	Escape	22
04	Manivelle, dispositif demarrage	Manivela, dispositivo de arranque	23
04	Décompression autom.	Decompresion autom.	24
04	Deblocage demarrage	Disparo de arranque	25
05	Demarreur, alternateur	Arrancador, alternador	26
05, 10	Boitier de bord	Cuadro de mando	27
05, 10	Équipement électrique, cable	Equipo eléctrico, cables	28
06	Pieds moteur, amort. vibrat.	Soportes del motor, amort. vibrac.	29
07	Radiateur d'huile, carter d'huile	Radiador de aceite, carter de aceite	30
08	Bati connexion, carter ventilation	Bastidor de conex., chapa de aire	31
12, 15	Protecteur courroie, bride raccord	Proteccion corea, caja de conexión	32
18	Couvercle p. hydr.	Tapa de mando p. hidráulico	33

M 00

Ersatzteilsätze  
Spare parts kits  
Jeux de pièces de rechange  
Juegos de piezas de recambios

M 34

Zubehör  
Accessories  
Accessoires  
Accesorios

Tafel Nr.  
Tabl. No.

01

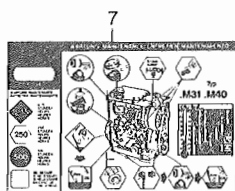
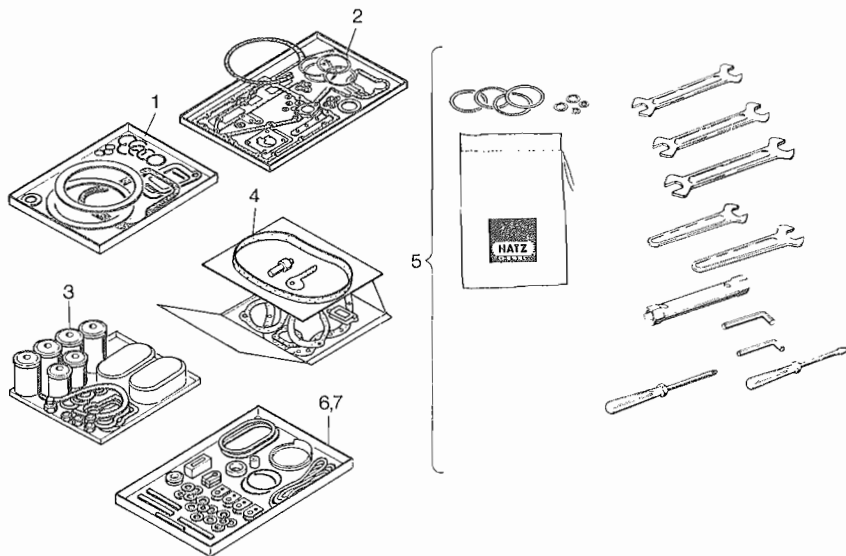

8

8

8

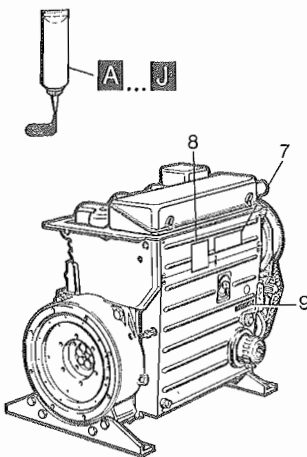

Fig. No.	Bestell-Nr.	Stück	Hinweise		
	Ordering No.	Quantity	Hints	Indications	
	No. référence	Quantités	Indicaciones		
	No. de pedido	Cantidades			

2 M... | 3 M... | 4 M...

P: Im Pannensatz enthalten. — Incl. in emergency kit. —  
 Contenu dans le jeu secour. —  
 Contenido en el juego para averias.

W: Im Wartungssatz enthalten. — Incl. in maintenance kit. —  
 Contenu dans le jeu d'entretien. — Contenido en el juego  
 de mantenimiento.

1: Anzahl pro Satz. — Qty. per kit. —  
 Quantite par jeu. — Cantidad por juego.

1	009 922 00 P1	2	3	4	Dichtungssatz f. 1 Zylinderkopf Joint set for 1 cyl. head Jeu de joint p. 1 culasse Juego de juntas para 1 culata
2	012 309 00	1	1	1	Dichtungssatz Kurbelgehäuse Gasket set crankcase Jeu de joints carter moteur Juego de juntas caja cigueñal
3	009 871 02	1	—	—	Wartungssatz für 1000 h
3	009 915 02	—	1	—	1000 hours maintenance kit
3	012 033 02	—	—	1	Kit d'entretien 1000 heures Juego de piezas para mantenimiento 1000 horas
4	012 262 01	1	1	1	Pannensatz, Emergency kit Kit de secours, Juego para averias
5	009 383 01	1	1	1	Zubehörsatz, Accessories kit, Sort. accessoires, Juego de accesorios
6	012 156 00	1	1	1	Gummiteilesatz, Rubber comp. set Garniture caout., Guarnicion goma
7	036 317 01	1	1	1	
8	034 306 11	1	1	1	
9	033 254 00	1	1	1	

Dicht- und Klebstoffe  
Sealing- and bonding adhesives

Etanchéifiant et Colle  
Materias para empaquetar y pegar

A	= 502 230 00	Loctite Activator	— 165 ml
B	= 502 231 00	Loctite 573	— 50 ml
C	= 502 232 00	Loctite 601	— 50 ml
D	= 502 233 00	Loctite 221	— 50 ml
E	= 502 234 00	Loctite 648	— 10 ml
F	= 502 238 00	Technicoll 8058	— 0,750 kg
+	502 239 00	Technicoll 8366	— 0,750 kg
G	= 502 565 01	Loctite IS 407	— 20 ml
H	= 502 825 00	Silicon	— 75 ml
I	= 502 830 00	Hochtemp. Paste	— 100 g

s. Hinweis auf den einzelnen Bildtafeln  
as specified in the individual tables  
suivant les remarques sur les tableaux  
correspondant  
Según las indicaciones de las tablas  
correspondientes



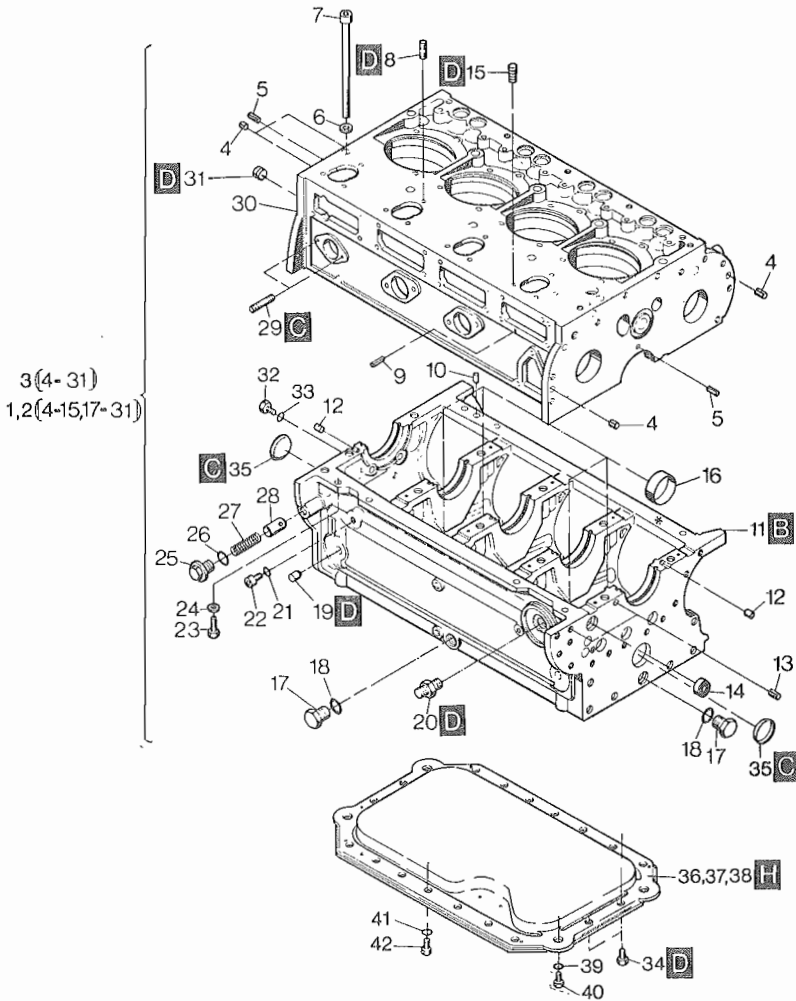

Fig. No.	Bestell-Nr. Ordering No. No. référence No. de pedido	Stück Quantity Quantites Cantidades			Hinweise Hints Indications Indicaciones	
		2 M...	3 M...	4 M...		
1	009 757 01	1	—	—		
2	009 918 01	—	1	—		
3	012 009 00	—	—	1		
4	501 400 00	4	4	4	8 x 8	DIN 7346
5	501 305 00	2	2	2	5 x 24	DIN 1481
6	034 693 00	6	8	10		
7	501 259 00	6	8	10	M 12x1,5x190	DIN 912-10.9
8	502 908 00	5	8	11	M 8x20	DIN 939-10.9
9	501 305 00	1	1	1	5 x 24	DIN 1481
10	036 353 00	1	1	1		
11	—	—	—	—		
12	501 314 00	2	2	2	10 m 6x14	DIN 7-St 50K
13	500 849 00	2	2	2	8x12	DIN 7346
14	501 302 00	1	1	1		
15	038 636 00	1	1	1		
16	036 271 00	—	—	4	48	
17	501 404 00 W1	2	2	2	AM 22x1,5	DIN 7604-5.8
18	500 016 00 W4	2	2	2	A 22x27	DIN 7603-Cu
19	036 457 00	1	1	1		$n \leq 1500 \text{ min}^{-1}$
20	400 654 00	1	1	1		
21	500 624 00	1	1	1	A 10x13,5	DIN 7603-Cu
22	500 623 00	1	1	1	M 10x1	DIN 908
23	500 268 00	8	12	17	8x20	DIN 933-8.8
24	500 028 00	8	12	17	8	DIN 128
25	032 493 00	1	1	1		
26	500 014 00 W4	1	1	1	A 18x22	DIN 7603-Cu
27	036 399 00	1	1	1		
28	036 398 00	1	1	1		
29	501 392 00	2	2	2	M 6x16	DIN 939-8.8
30	—	—	—	—		
31	500 438 00	1	1	1	M 14x1,5	DIN 906
32	500 265 00	2	2	—	M 8x10	DIN 933-8.8
33	501 629 00	2	2	—	M 8x14	DIN 7603-Cu
34	502 793 00	4	4	—	M 8x16	DIN 933-8.8
35	501 408 00	2	2	—	38	DIN 443
36	037 526 01	1	—	—		

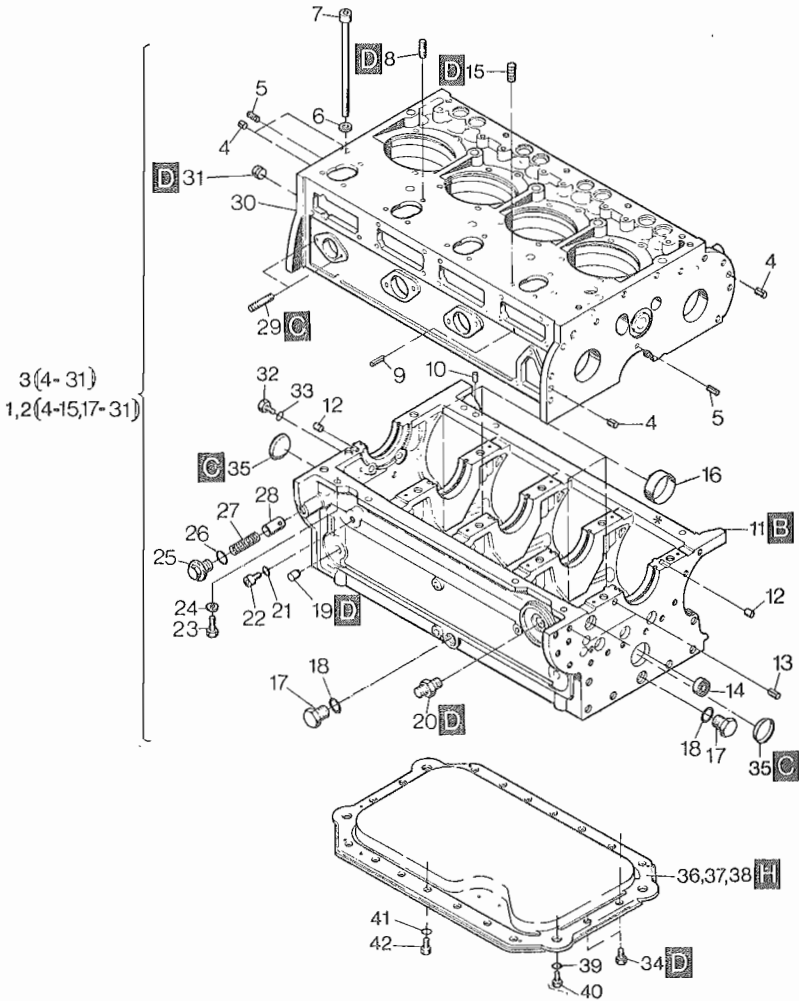

Fig. No.	Bestell-Nr. Ordering No. No. référence No. de pedido	Stück Quantity Quantites Cantidades			Hinweise Hints Indications Indicaciones
		2 M...	3 M...	4 M...	
37	037 527 01	—	1	—	
38	—	—	—	—	s. Taf., Tabl.30, Pos. 44
39	500 030 00	4	4	—	12            DIN 128
40	500 806 00	4	4	—	M 12x20    DIN 912-8.8
41	500 028 00	8	14	—	8            DIN 128
42	500 267 00	8	14	—	M 8x16     DIN 933-8.8

M 01

Kurbelgehäuse  
Crankcase  
Carter moteur  
Caja cigueñal

Tafel Nr.  
Tabl. No.

03

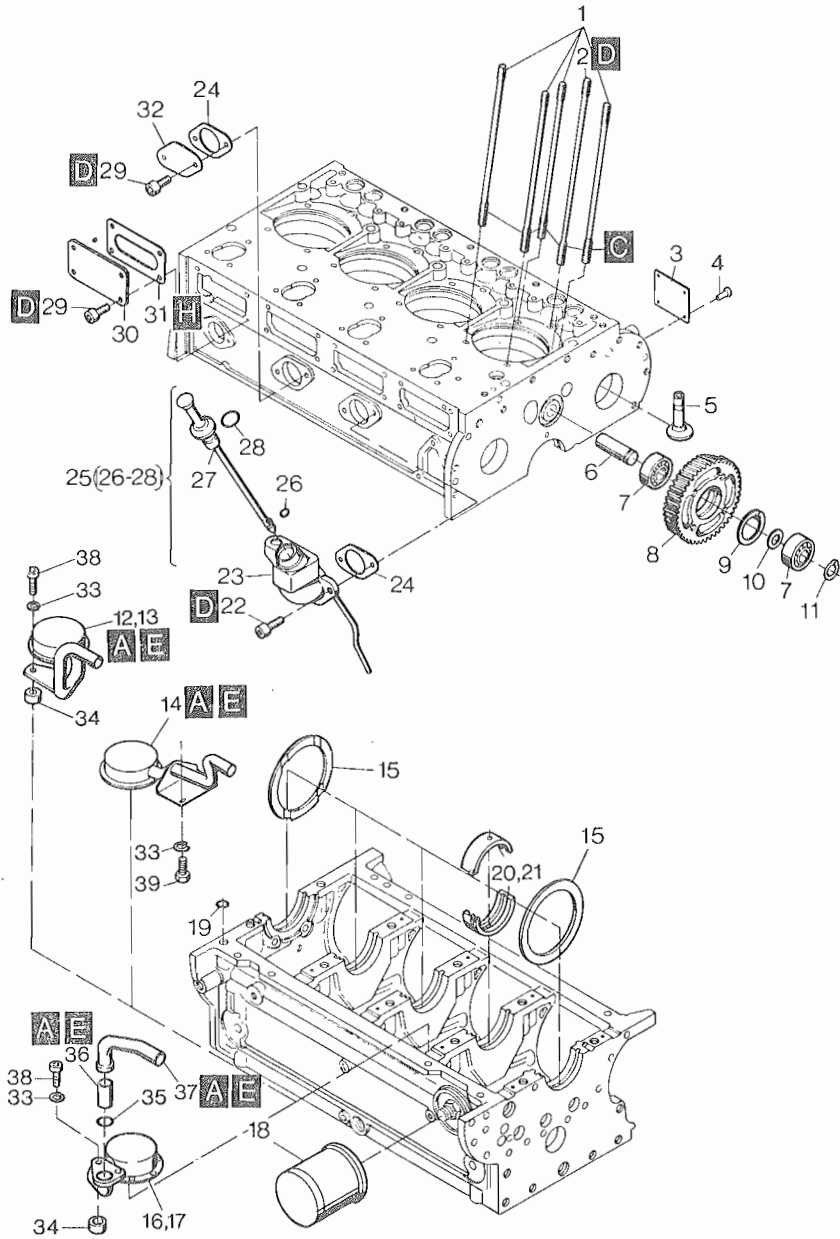

Fig. No.	Bestell-Nr. Ordering No. No. référence No. de pedido	Stück Quantity Quantites Cantidades			Hinweise Hints Indications Indicaciones
		2M...	3M...	4M...	
1	036 257 02	8	12	16	
2	036 258 02	2	3	4	
3	032 255 03	1	1	1	
4	400 025 00	4	4	4	
5	035 545 01	4	6	8	
6	034 696 01	1	1	1	
7	500 137 00	2	2	2	
8	035 617 02	1	1	1	
9	500 217 00	1	1	1	47x1,75     DIN 472
10	034 623 00	1	1	1	
11	501 276 00	1	1	1	20x1,75     DIN 471
12	009 293 01	1	—	—	
13	009 294 01	—	1	—	
14	009 292 01	—	—	1	f. Taf./Tabl. 30, Pos. 44, 60
15	034 633 00	2	2	2	
16	009 290 01	1	—	—	} f. Taf./Tabl. 30, Pos. 42, 43 58, 59
17	009 291 01	—	1	—	
18	400 653 00 W4	1	1	1	
19	502 194 00	1	1	1	
20	035 555 00	3	4	5	72 mm $\phi$
21	035 516 00	3	4	5	71,5 mm $\phi$ 0,5 —
22	500 519 00	2	2	2	M 8x20     DIN 912-8.8
23	009 326 02	1	—	—	
23	009 148 03	—	1	1	
24	501 290 00	1	1	2	36     DIN 71511
25	007 397 02	1	1	—	„A“
25	009 311 00	1	—	—	„C“
25	009 308 00	—	1	1	„D“
26	502 025 02	1	1	1	} f. Taf./Tabl. 30, Pos. 42, 43, 44, 58, 59, 60
27	—	—	—	—	
28	501 399 00	1	1	1	
29	501 289 00	4	8	14	M 8x16     DIN 912-8.8
30	034 692 00	1	2	3	
31	035 513 00	1	2	3	
32	032 633 00	—	—	1	
33	500 028 00	2	2	2	8     DIN 128

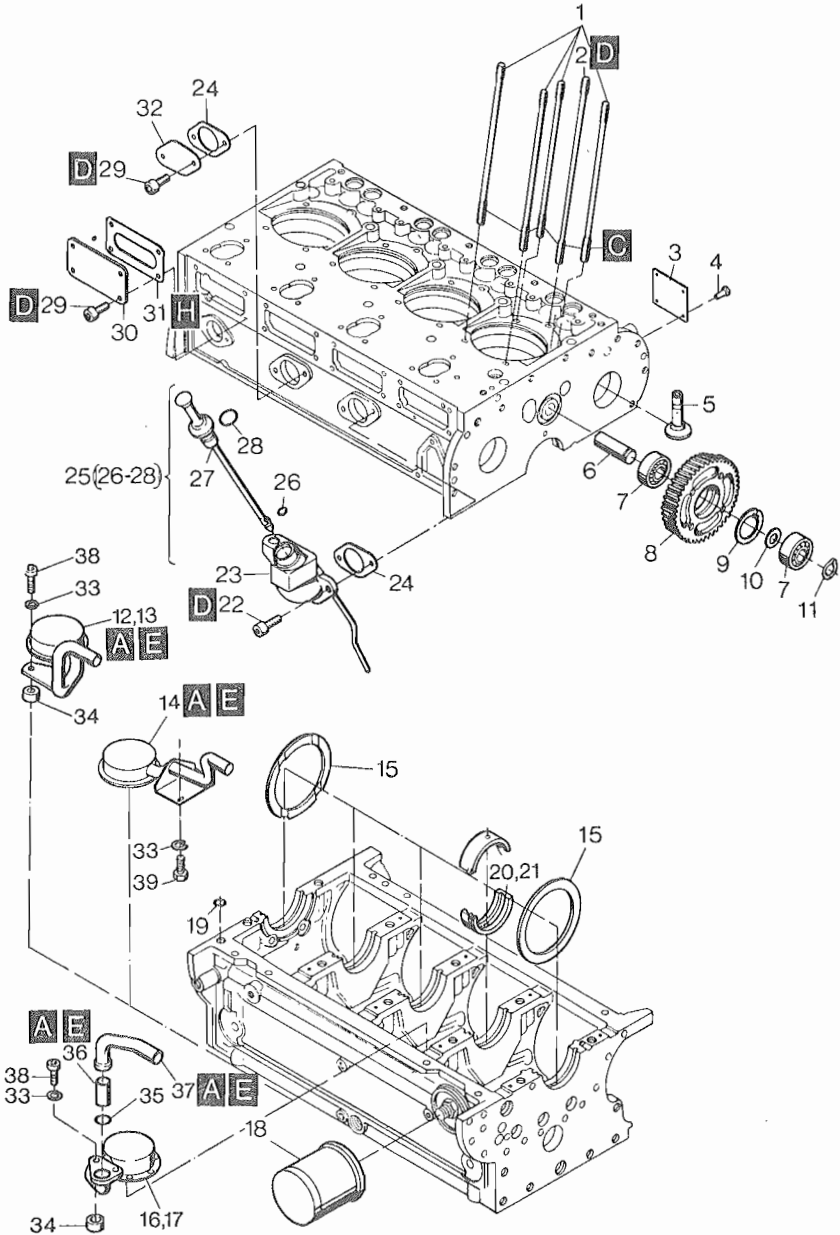

Fig. No.	Bestell-Nr. Ordering No. No. référence No. de pedido	Stück Quantity Quantites Cantidades			Hinweise Hints Indications Indicaciones
		2 M...	3 M...	4 M...	
34	034 670 00	2	2	—	} f. Taf./Tabl. 30, Pos. 42, 43 58, 59
35	502 580 00	1	1	—	
36	036 176 00	1	1	—	
37	036 165 00	1	1	—	} M 8x20      DIN 912-8.8 M 8x16      DIN 933-8.8
38	500 519 00	2	2	—	
39	500 267 00	—	—	2	



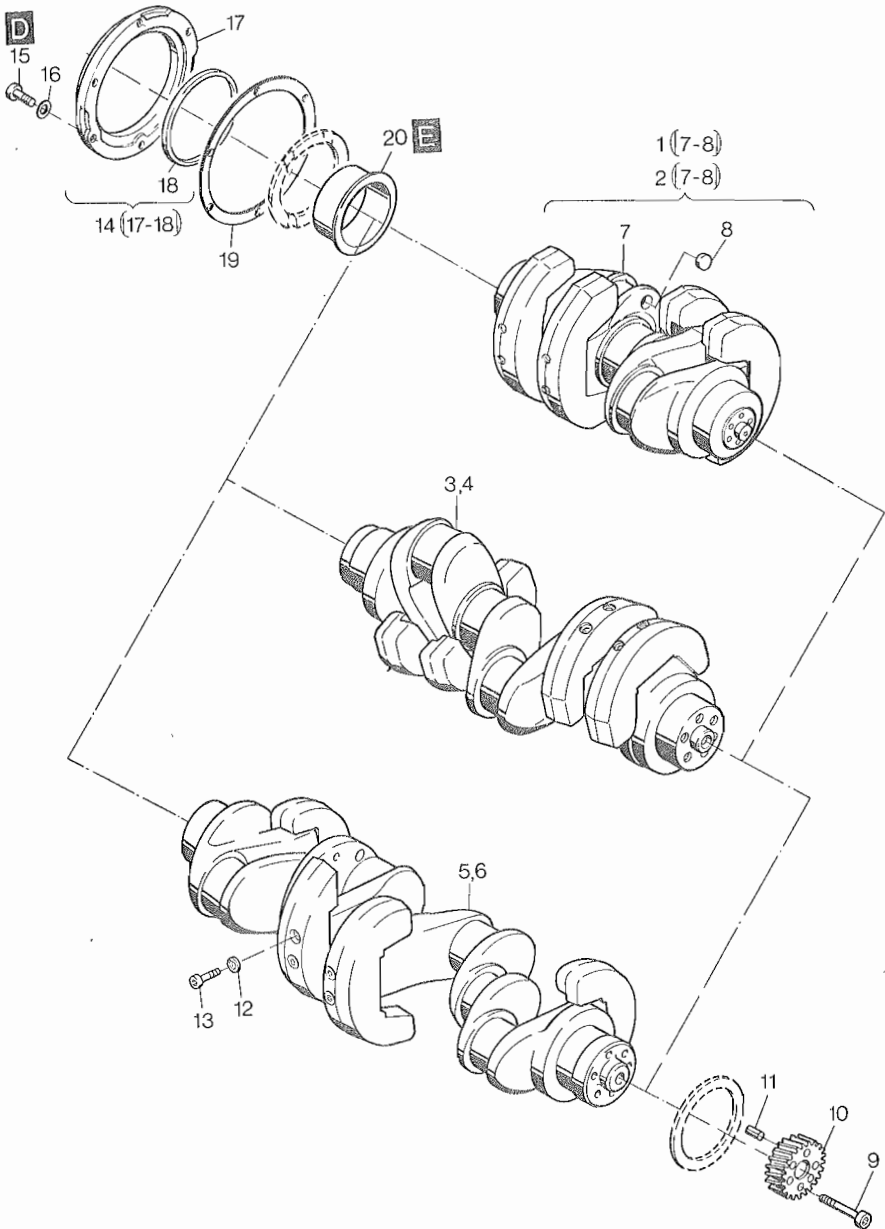

Fig. No.	Bestell-Nr. Ordering No. No. référence No. de pedido	Stück Quantity Quantites Cantidades			Hinweise Hints Indications Indicaciones
		2 M...	3 M...	4 M...	
1	009 727 00	1	—	—	2 M 31
2	009 508 01	1	—	—	2 M 40
3	009 902 00	—	1	—	3 M 31
4	009 550 00	—	1	—	3 M 40
5	009 948 00	—	—	1	4 M 31
6	009 563 00	—	—	1	4 M 40
7	—	—	—	—	
8	502 072 00	2	—	—	2 L 40
9	501 279 00	6	6	6	M 8x40      DIN 912-10.9
10	035 616 01	1	1	1	
11	501 280 00	1	1	1	11x10      DIN 7346 55SI 7
12	500 029 00	8	8	8	10          DIN 128
13	501 328 00	8	8	8	M 10x40      DIN 912-10.9
14	009 575 00	1	1	1	
15	502 366 00	6	6	6	M 6x25      DIN 912-8.8
16	500 812 00	6	6	6	A 6          DIN 137
17	—	—	—	—	
18	502 246 01	1	1	1	80x100x10
19	035 506 01	1	1	1	
20	037 806 00	0...1	0...1	0...1	80 mm

M 04

Nockenwelle, Regler, Spritzversteller  
Camshaft, governor, timer  
Arbre à cames, regulateur, variateur d'avance  
Arbol de levas, regulador, variador de avance

Tafel Nr.  
Tabl. No.

05

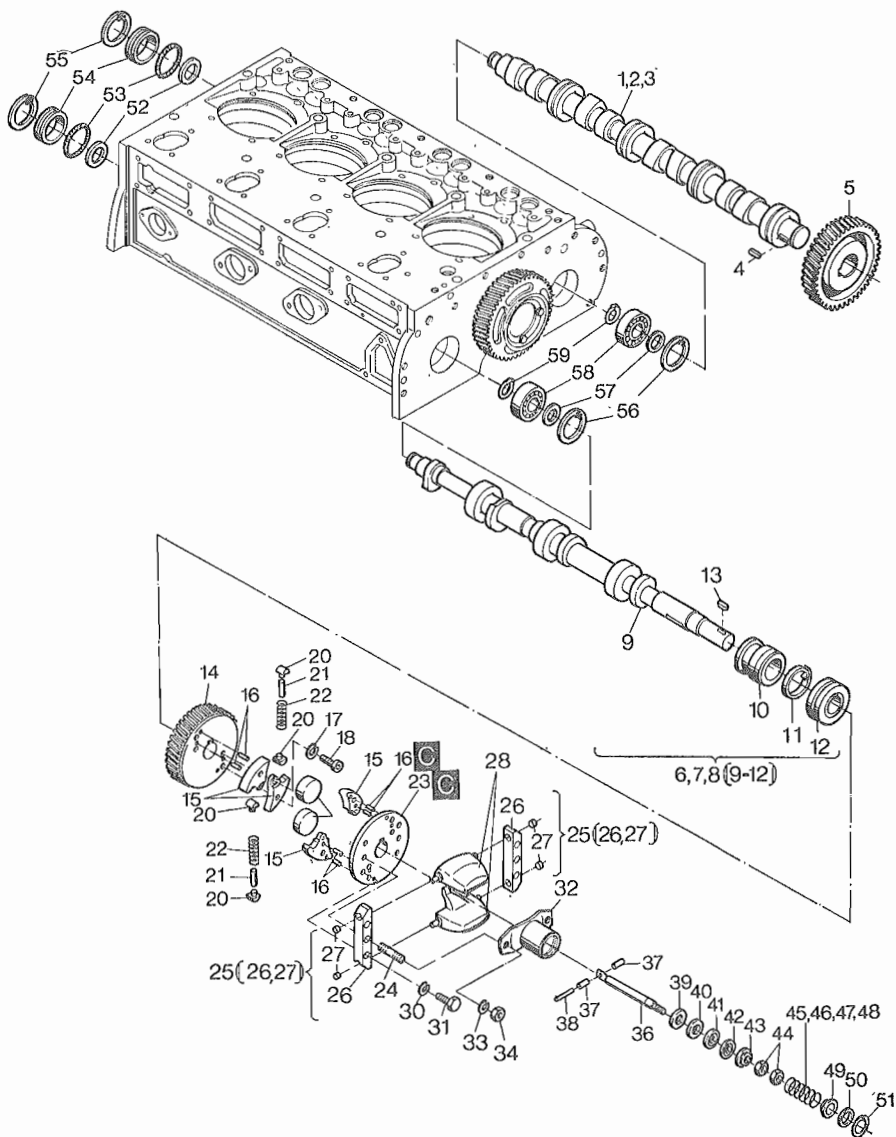

Fig. No.	Bestell-Nr. Ordering No. No. référence No. de pedido	Stück Quantity Quantites Cantidades			Hinweise Hints Indications Indicaciones	
		2 M...	3 M...	4 M...		
1	035 567 00	1	—	—	} „L“	
2	035 557 00	—	1	—		
3	035 580 00	—	—	1		
1	037 794 00	1	—	—	} „H“	
2	037 795 00	—	1	—		
3	037 796 00	—	—	1		
4	500 113 00	1	1	1	A 8x7x22	DIN 6885
5	035 618 00	1	1	1		
6	012 120 00	1	—	—		
7	012 121 00	—	1	—		
8	012 122 00	—	—	1		
9	—	—	—	—		
10	—	—	—	—		
11	035 765 01	1	1	1		
12	—	—	—	—		
13	501 316 00	1	1	1	A 6x6x20	DIN 6885 ST6
14	035 619 00	1	1	1		
15	034 627 01	4	4	4		
16	500 579 00	8	8	8	4 m 6x8	DIN 7-9S 20K
17	501 401 00	8	8	8	6	DIN 7980
18	501 432 00	8	8	8	M 6x18	DIN 6912-8.8
19	034 601 00	2	2	2		
20	034 645 00	4	4	4		
21	035 613 00	2	2	2		
22	035 61400	2	2	2		
23	035 547 00	1	1	1		
24	501 315 00	2	2	2	M 8x30	DIN 938-8.8
25	007 458 00	2	2	2		
26	—	—	—	—		
27	035 721 00	4	4	4		
28	035 729 00	2	2	2		
30	501 282 00	4	4	4	8	
31	500 270 00	4	4	4	M 8x25	DIN 938-8.8
32	037 731 01	1	1	1		
33	400 278 00	2	2	2	8	
34	500 229 00	2	2	2		

M 04

Nockenwelle, Regler, Spritzversteller  
Camshaft, governor, timer  
Arbre à cames, regulateur, variateur d'avance  
Arbol de levas, regulador, variador de avance

Tafel Nr.  
Tabl. No.

05

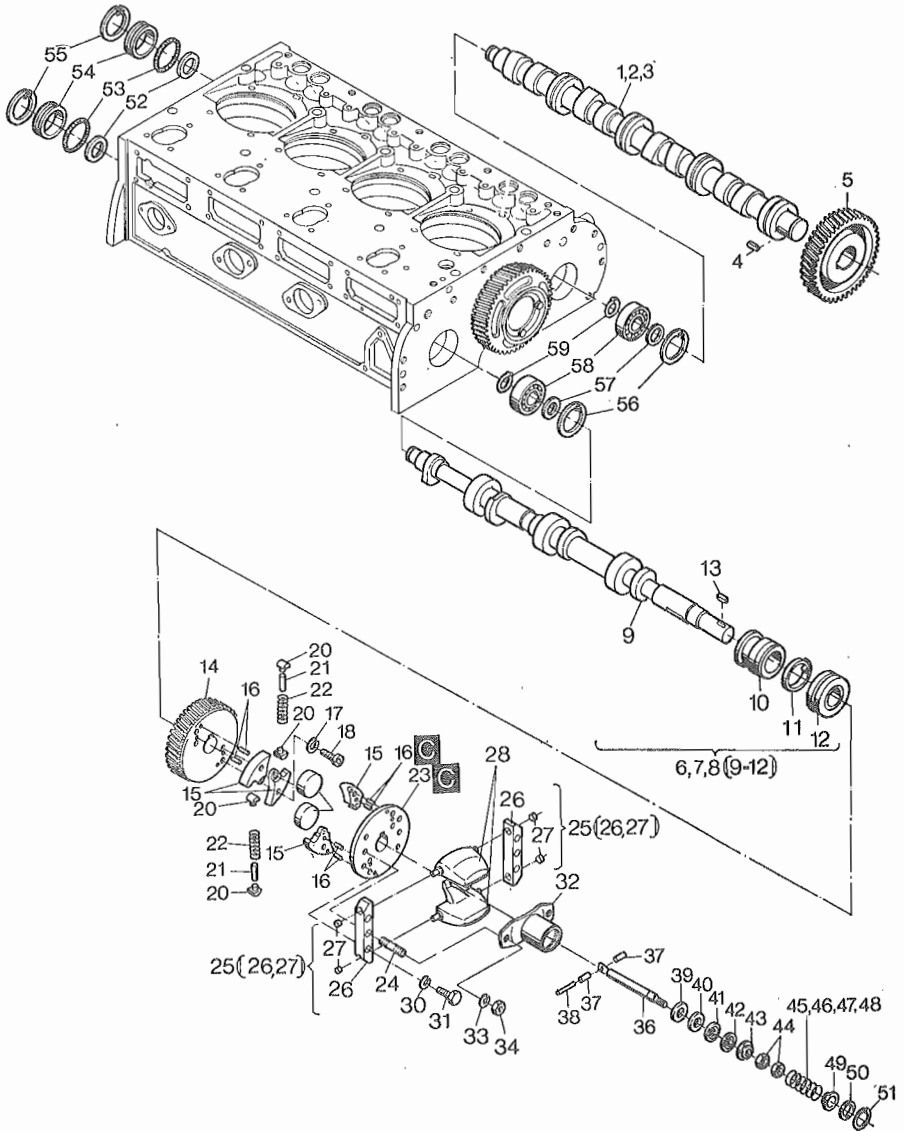

Fig. No.	Bestell-Nr. Ordering No. No. référence No. de pedido	Stück Quantity Quantites Cantidades			Hinweise Hints Indications Indicaciones	
		2 M...	3 M...	4 M...		
35	---	---	---	---		
36	037 726 00	1	1	1		
37	037 725 00	2	2	2		
38	035 764 00	1	1	1		
39	037 727 00	1	1	1		
40	502 680 00	1	1	1	6x12x0,5	DIN 988
41	502 681 00	1	1	1		
42	502 682 00	1	1	1		
43	037 728 00	1	1	1		
44	500 227 00	2	2	2	M 6	DIN 934-8
45	036 014 01	1	1	1	2,5 mm $\phi$	1500 min <sup>-1</sup> Gen
46	036 013 01	1	1	1	2,6 mm $\phi$	1800 min <sup>-1</sup> Gen
47	036 012 01	1	1	1	3,0 mm $\phi$	$\leq$ 2300 min <sup>-1</sup>
48	035 744 01	1	1	1	3,2 mm $\phi$	$>$ 2300 min <sup>-1</sup>
49	035 719 00	1	1	1		
50	037 729 00	1	1	1		
51	500 210 00	1	1	1	32x1,2	DIN 472
52	501 327 00	0...4	0...4	0...4	37x47x0,1	DIN 472
52	502 773 00	0...1	0...1	0...1	37x47x0,5	DIN 988
53	501 307 00	2	2	2		
54	034 697 00	2	2	2		
55	500 217 00	2	2	2	47x1,75	DIN 472
56	500 217 00	2	2	2	47x1,75	DIN 472
57	501 329 00	0...3	0...3	0...3	20x28x0,1	DIN 988
58	500 137 00	2	2	2	C 3	DIN 6204
59	501 276 00	2	2	2	AS 20x1,75	DIN 471

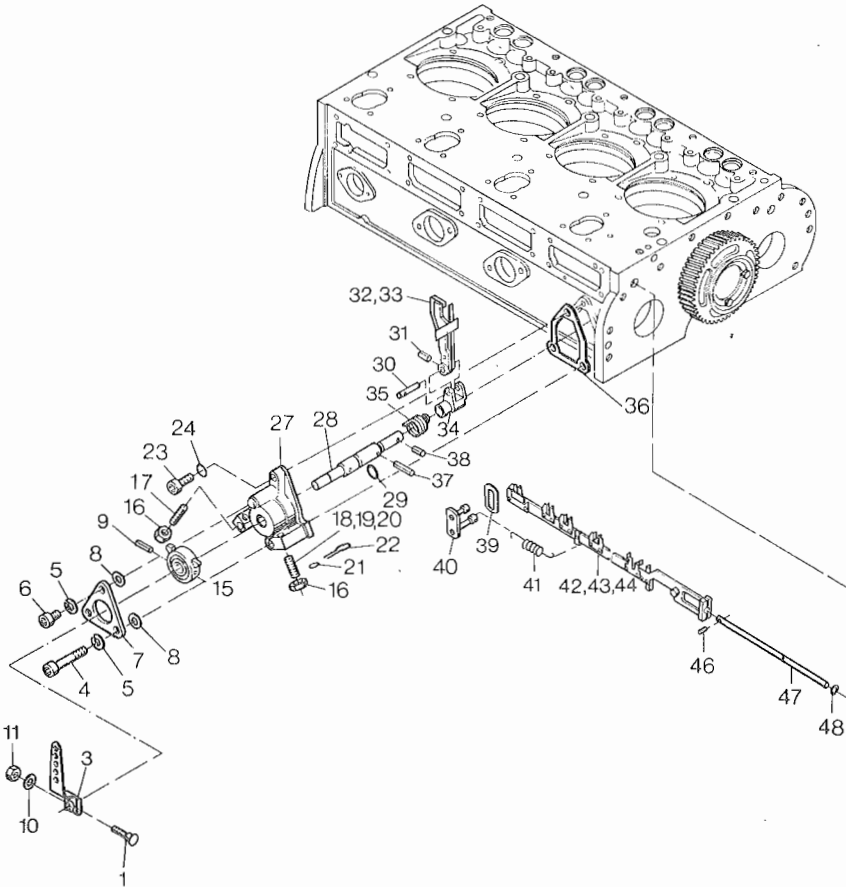

Fig. No.	Bestell-Nr.	Stück			Hinweise	
	Ordering No.	Quantity	Quantity	Quantity	Hints	Indications
	No. référence	Quantités	Quantités	Quantités	Indications	Indicaciones
	No. de pedido	Cantidades	Cantidades	Cantidades		
		2 M...	3 M...	4 M...		
1	039 273 00	1	1	1	M 6x32	
2	—	—	—	—		
3	038 883 00	1	1	1		
4	500 530 00	2	2	2	M 8x70	DIN 912-8.8
5	501 282 00	3	3	3	8	DIN 127
6	500 516 00	1	1	1	M 8x16	DIN 912-8.8
7	034 658 00	1	1	1		
8	032 130 00	0...3	0...3	0...3	0,3 mm	
8	032 131 00	0...3	0...3	0...3	0,5 mm	
9	500 350 00	1	1	1	5x40	DIN 1481
10	501 143 00	1	1	1	6,4	DIN 7349 Zn
11	501 444 00	1	1	1	M 6	DIN 934-8 A3C
12	—	—	—	—		
13	—	—	—	—		
14	—	—	—	—		
15	034 688 10	1	1	1		
16	500 229 00	2	2	2	M 8	DIN 934-8
17	032 459 00	1	1	1	AM 8x35	
18	032 459 00	1	1	1	AM 8x35	n > 2600 min <sup>-1</sup>
19	036 429 00	1	1	1	AM 8x45	n = 2200...2600 min <sup>-1</sup>
19	037 740 00	1	1	1	AM 8x40	n = 2200...2600 min <sup>-1</sup>
20	031 695 01	1	1	1	AM 8x50	n < 2200 min <sup>-1</sup>
21	400 214 00	1	1	1		
22	400 215 00	1	1	1		
23	500 519 00	1	1	1	M 8x20	DIN 912-8.8
24	501 629 00	1	1	1	A 8x14	DIN 7603-Cu
25	—	—	—	—		
26	—	—	—	—		
27	035 542 11	1	1	1		
28	034 689 40	1	1	1		
29	400 817 00	1	1	1		
30	034 690 10	1	1	1		
31	501 275 00	1	1	1	3x14	DIN 1481
32	010 862 00	1	1	1		
33	—	—	—	—		
34	034 691 10	1	1	1		



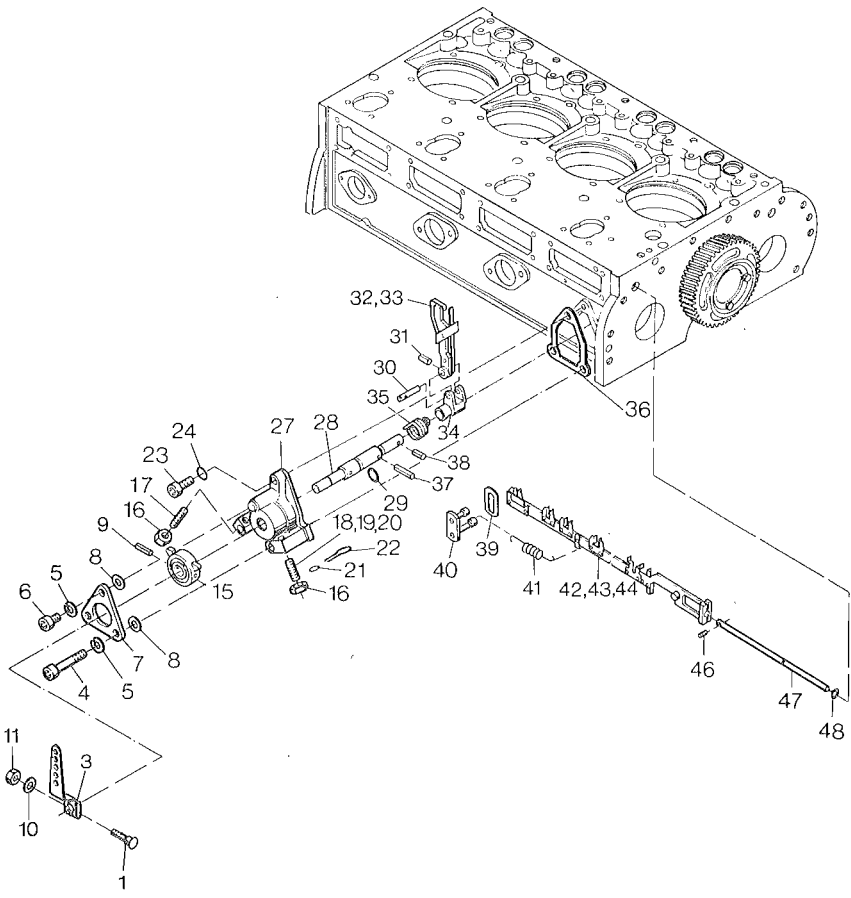

Fig. No.	Bestell-Nr. Ordering No. No. référence No. de pedido	Stück Quantity Quantities Cantidades			Hinweise Hints Indications Indicaciones	
		2 M...	3 M...	4 M...		
35	038 614 00	1	1	1		
36	034 659 00	1	1	1		
37	502 690 00	1	1	1	4x26	DIN 1481
38	501 319 00	1	1	1	4x12	DIN 1481
39	038 650 00	0...3	0...3	0...3		
40	010 667 00	1	1	1		
41	034 681 00	1	1	1		
42	010 668 02	1	—	—		
43	010 669 02	—	1	—		
44	010 670 02	—	—	1		
46	501 318 00	1	1	1	2,5x10	DIN 1481
47	034 606 00	1	1	1		
48	400 223 00	1	1	1		

**M 05**

Kolben, Pleuel  
Piston, conrod  
Piston, bielle  
Embolo, biela

**M 06**

Zylinder  
Cylinder  
Cylindre  
Cilindro

Tafel Nr.  
Tabl. No.

07

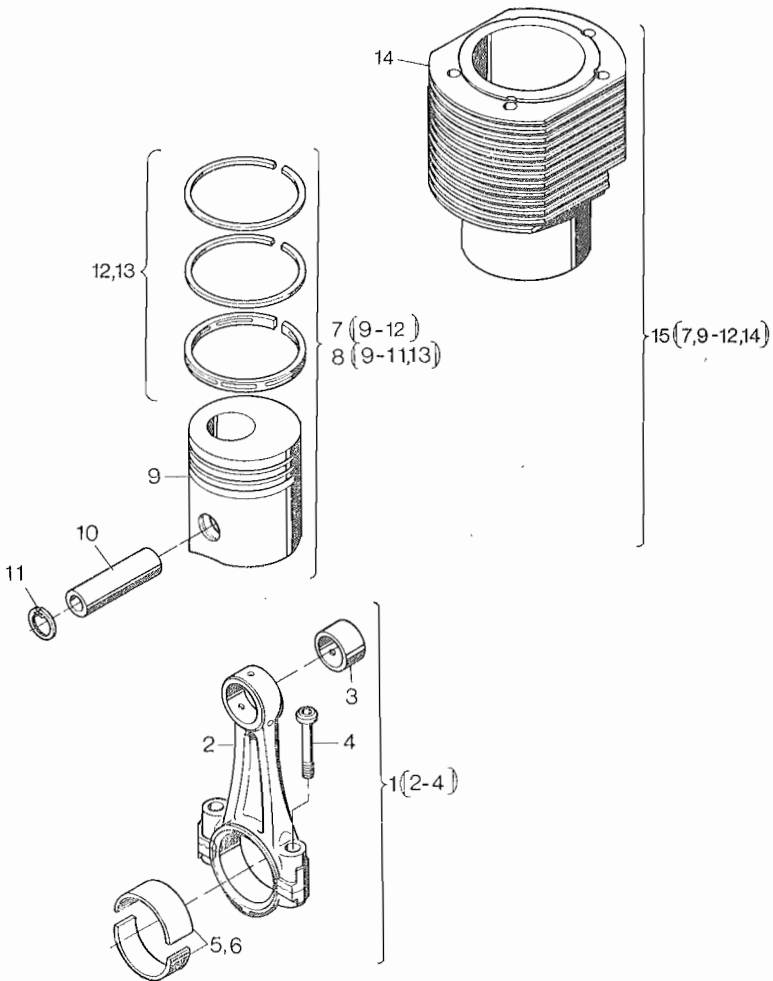

Fig. No	Bestell-Nr. Ordering No. No. référence No. de pedido	Stück Quantity Quantities Cantidades						Hinweise Hints Indications Indicaciones
		2 M 31	3 M 31	4 M 31	2 M 40	3 M 40	4 M 40	
1	009 297 02	2	3	4	2	3	4	
2	—	—	—	—	—	—	—	
3	037 530 00	2	3	4	2	3	4	
4	037 752 00	4	6	8	4	6	8	
5	036 184 01	2	3	4	2	3	4	
6	037 531 00	2	3	4	2	3	4	- 0,5 mm
7	012 136 00	2	3	4	—	—	—	
7	009 541 01	—	—	—	2	3	4	
8	012 359 00	2	3	4	—	—	—	+ 0,5 mm
8	012 357 00	—	—	—	2	3	4	+ 0,5 mm
9	—	—	—	—	—	—	—	
10	502 361 00	2	3	4	2	3	4	
11	502 360 00	4	6	8	4	6	8	36x1,5      DIN 472
12	009 558 00	2	3	4	2	3	4	
13	012 358 00	2	3	4	2	3	4	+ 0,5 mm
14	—	—	—	—	—	—	—	
15	012 182 00	2	3	4	—	—	—	
15	009 734 01	—	—	—	2	3	4	

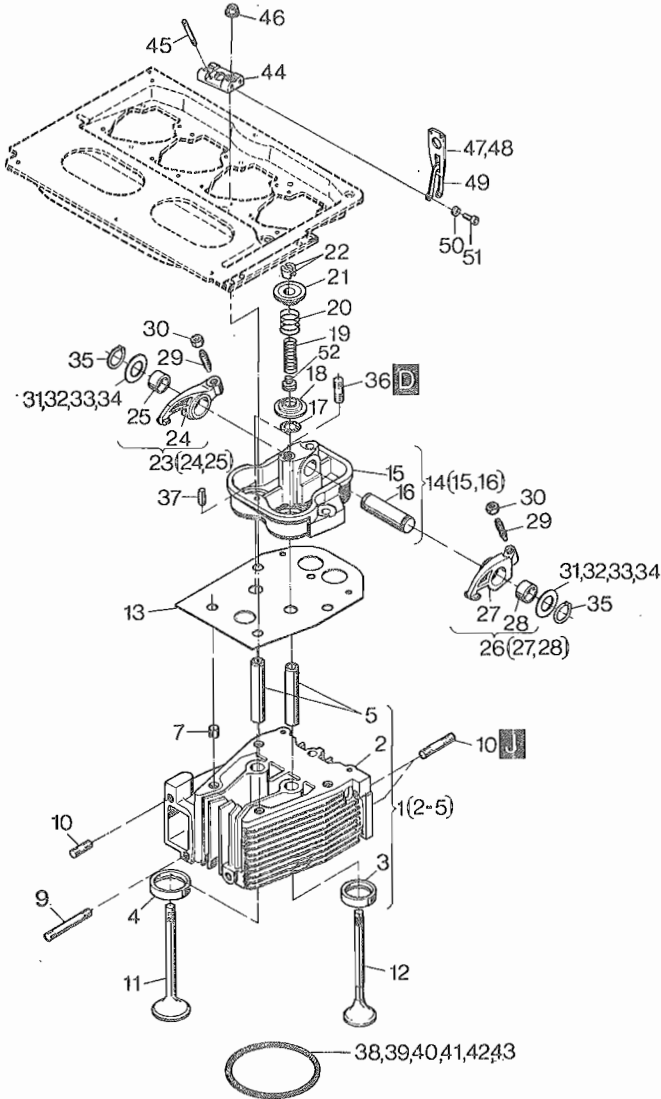

Fig. No.	Bestell-Nr. Ordering No. No. référence No. de pedido	Stück Quantity Quantities Cantidades			Hinweise Hints Indications Indicaciones	
		2 M...	3 M...	4 M...		
1	009 330 01	2	3	4	„L“	
1	009 936 00	2	3	4	„H“	
2	—	—	—	—		
3	—	—	—	—		
4	—	—	—	—		
5	034 487 01	4	6	8		
6	—	—	—	—		
7	502 248 00	8	12	16	13x14	DIN 7346
8	—	—	—	—		
9	501 325 00	2	3	4	M 8x65	DIN 835-8.8
10	501 281 00	6	9	12	M 8x30	DIN 835-10.9
11	036 255 01	2	3	4		
12	036 256 00	2	3	4		
13	036 248 00	2	3	4		
14	009 562 00	2	3	4		
15	—	—	—	—		
16	034 698 00	2	3	4		
17	502 881 00	4	6	8	15,3 x 3,2	
18	033 930 10	4	6	8		
19	031 835 00	4	6	8	„L“	
20	033 256 00	4	6	8		
21	030 434 02	4	6	8		
22	036 209 00	4	6	8		
23	005 325 00	2	3	4		
24	—	—	—	—		
25	031 841 00	2	3	4		
26	009 328 00	2	3	4		
27	—	—	—	—		
28	031 841 00	2	3	4		
29	030 431 00	4	6	8	$n > 2300 \text{ min}^{-1}$	
29	037 720 00	4	6	8	$n \leq 2300 \text{ min}^{-1}$	
30	031 490 00 W2	4	6	8		
31	035 806 00	0...4	0...6	0...8	0,15 mm	
32	032 332 00	0...4	0...6	0...8	0,20 mm	
33	032 333 00	0...4	0...6	0...8	0,30 mm	
34	034 560 00	0...4	0...6	0...8	0,40 mm	

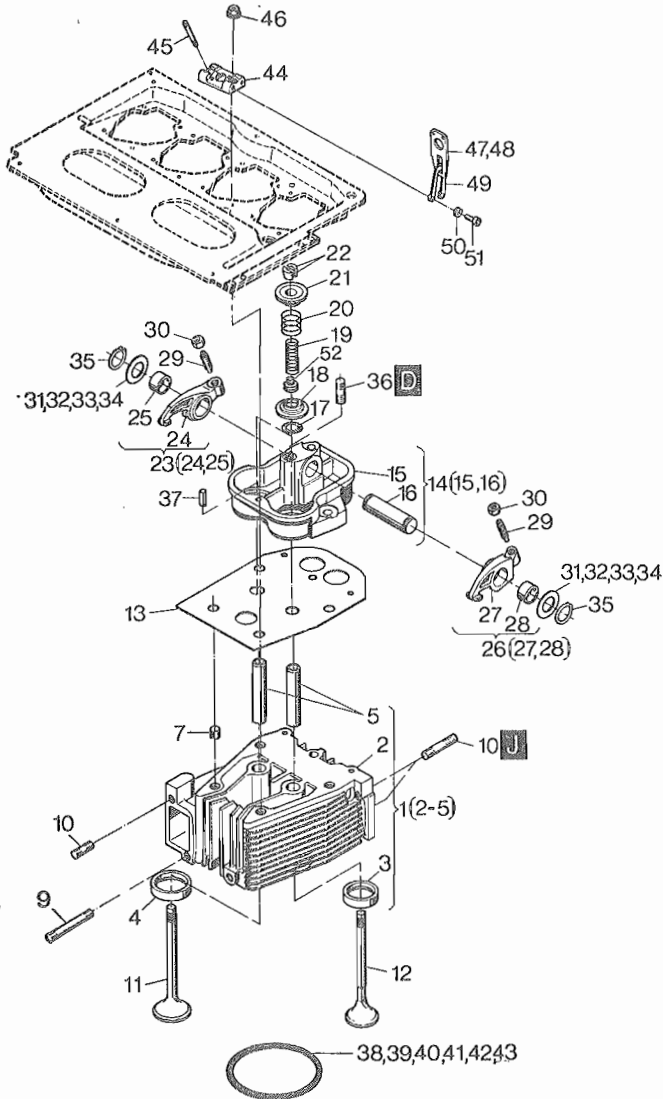

Fig. No.	Bestell-Nr. Ordering No. No. référence No. de pedido	Stück Quantity Quantities Cantidades			Hinweise Hints Indications Indicaciones	
		2 M...	3 M 40	4 M...		
35	500 202 00	4	6	8	19x1,2	DIN 471
36	500 405 00	2	3	4	M 10x25	DIN 939-5.6
37	500 352 00	2	3	4	6x12	DIN 1481
38	036 259 01	0...2	0...3	0...4	0,7 mm	
39	036 260 01	0...2	0...3	0...4	0,8 mm	
40	036 261 01	0...2	0...3	0...4	0,9 mm	
41	036 262 01	0...2	0...3	0...4	1,0 mm	
42	036 263 01	0...2	0...3	0...4	1,1 mm	
43	036 264 01	0...2	0...3	0...4	1,2 mm	
44	036 249 00	2	3	4		
45	502 390 00	4	6	8	M 8x55	DIN 933-8.8
46	036 481 00 P5	10	15	20		
47	—	—	—	—		
48	—	—	—	—		
49	036 250 00	1	1	1		
50	501 282 00	2	2	2	8	DIN 127
51	501 297 00	2	2	2	M 8x18	DIN 912-10.9
52	502 848 00	4	6	8	$n \leq 2300 \text{ min}^{-1}$	





Fig. No.	Bestell-Nr. Ordering No. No. référence No. de pedido	Stück Quantity Quantites Cantidades			Hinweise Hints Indications Indicaciones	
		2 M...	3 M...	4 M...		
1	502 249 00 W4/6/8	2	3	4	123x2,5	
2	—	—	—	—		
3	036 426 01	2	3	4		
4	501 323 00 W2/3/4	2	3	4	M 10	
5	007 436 00	4	6	8		
6	035 667 01	4	6	8		
7	031 851 00	4	6	8	17x3	
8	031 852 00	4	6	8		
9	502 580 00	4	6	8		
10	009 242 04	1	1	—		
11	009 239 04	—	—	1		
12	035 620 20	1	1	1		
13	503 168 00	1	1	1	4x4x20	DIN 6885
14	—	—	—	—		
15	502 068 00	3	3	3	M 8x105	DIN 912-8.8
16	500 028 00	3	3	3		
17	400 228 00	4	6	8	8	DIN 128
18	502 894 00	0 ... 1	0 ... 1	0 ... 1		
					15x3,2	
					55 mm	

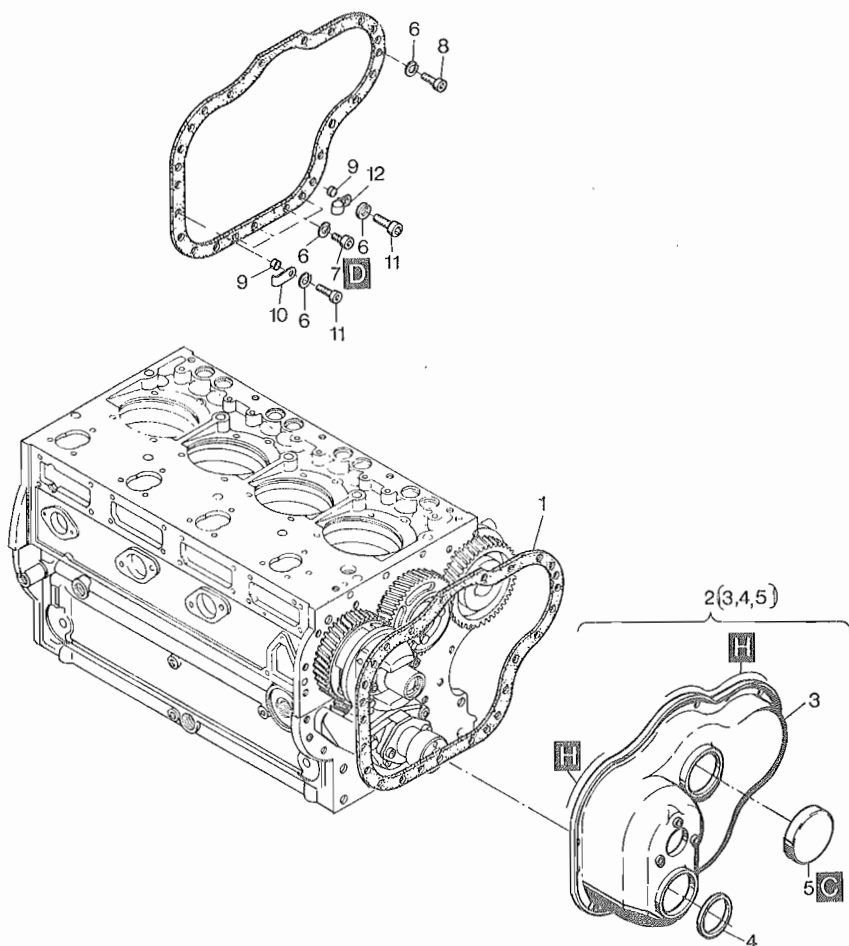

Fig. No.	Bestell-Nr. Ordering No. No. référence No. de pedido	Stück Quantity Quantites Cantidades	Hinweise Hints Indications Indicaciones	
		2... 4 M...		
1	035 569 01	1		
2	009 932 00	1		
3	—	—		
4	501 291 00	1	55x70x8	
5	501 265 00	1	70	DIN 442
6	500 028 00	22	8	DIN 128
7	502 058 00	4	M 8x12	DIN 912-8.8
8	500 516 00	15	M 8x16	DIN 912-8.8
9	031 167 00	2		
10	031 592 00	1		
11	500 521 00	2	M 8x25	DIN 912-8.8
12	031 655 00	1		

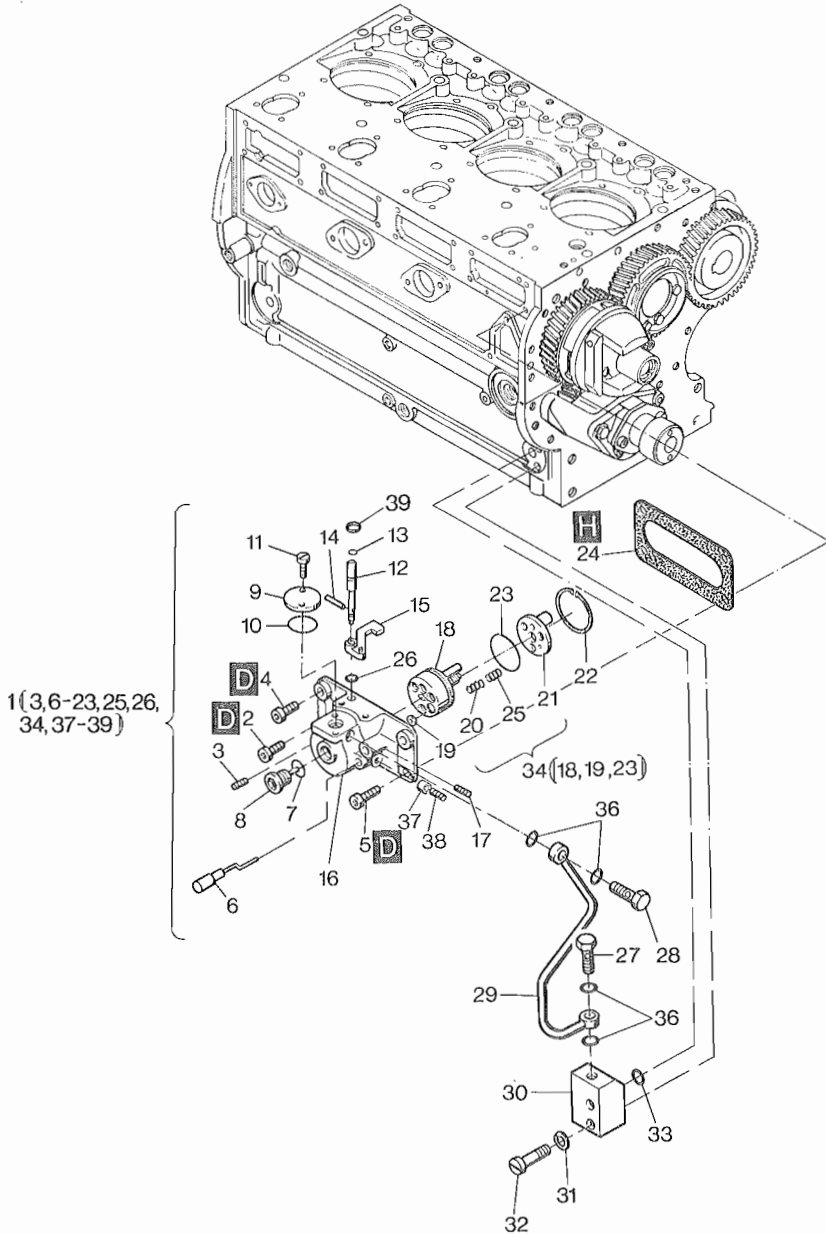

Fig. No.	Bestell-Nr. Ordering No. No. référence No. de pedido	Stück Quantity Quantities Cantidades	Hinweise Hints Indications Indicaciones	
2... 4M...				
1	012 019 03	1		
2	501 349 00	1	M 8x16	DIN 6912-8.8
3	502 624 00	1	M 6x10	DIN 916
4	501 289 00	1	M 8x16	DIN 912
5	400 808 00	2	M 8x20	DIN 912
6	010 762 00	1		
7	500 012 00	1	14x18	DIN 7603-Cu
8	010 978 00	1	M 14x1,5	DIN 908
9	038 591 00	1		
10	501 304 00	1		
11	503 180 00	2	16,3x2,4	
12	038 288 00	1	M 4x8	DIN 912-8.8
13	400 217 00	1		
14	501 318 00	1	4,47x8,03x1,78	
15	036 702 10	1	2,5x10	DIN 1481
16	—	—		
17	502 863 00	1	6x16	DIN 915-45 H
18	—	—		
19	038 515 01	1		
20	038 811 00	3		
21	038 542 00	1		
22	500 215 00	1	42x1,75	DIN 472
23	502 631 00	1	37,8x1,5	
24	036 140 00	1		
25	038 813 00	3		
26	501 172 00	1	4	DIN 6799
27	039 170 00	1		
28	500 061 00	1	A 2/3	DIN 7623-Zn
29	038 801 00	1		
30	038 806 00	1		
31	500 035 00	2	B 8	DIN 137
32	500 523 00	2	M 8x35	DIN 912-8.8
33	501 304 00	1	16,3x2,4	
34	012 018 11	1		
35	—	—		
36	500 009 00	4	A 8x11,5	DIN 7603-Cu
37	038 895 00	1		
38	502 623 00	1	M 4x10	DIN 915-45H TU
39	503 244 00	1		

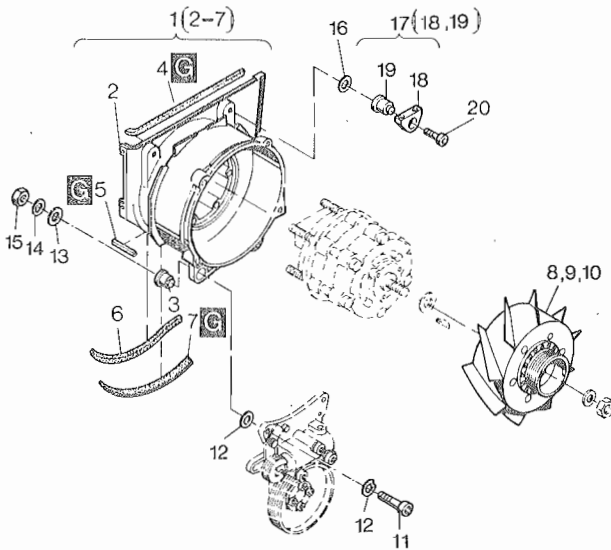

Fig. No.	Bestell-Nr. Ordering No. No. référence No. de pedido	Stück Quantity Quantites Cantidades			Hinweise Hints Indications Indicaciones	
		2 M...	3 M...	4 M...		
1	007 402 02	1	1	—		
1	012 037 01	—	—	1		
2	—	—	—	—		
3	035 625 00	2	2	2		
4	035 526 00	1	1	1	335 mm	
5	035 985 00	1	1	1	33 mm	
6	035 524 01	1	1	1	240 mm	
7	036 127 00	1	1	1	193 mm	
8	009 590 00	1	—	—		
9	009 897 00	—	1	—		
10	009 900 10	—	—	1		
11	500 551 00	2	2	2	M 10x55	DIN 912-8.8
12	500 617 00	4	4	4	A 10	DIN 137
13	500 706 00	2	2	2	10,5	DIN 7349
14	501 278 00	2	2	2	A 10	DIN 127
15	500 235 00	2	2	2	M 10	DIN 934-8
16	035 956 00	0...4	0...4	0...4		
17	009 198 00	2	2	2		
18	—	—	—	—		
19	035 526 00	2	2	2		
20	500 526 00	2	2	2	M 8x45	DIN 912-8.8



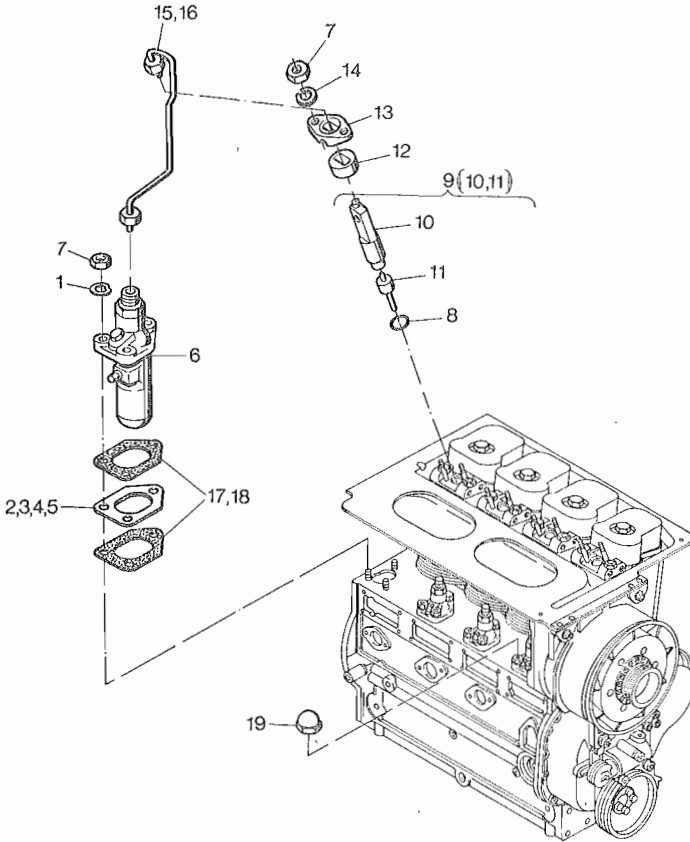

Fig. No.	Bestell-Nr. Ordering No. No. référence No. de pedido	Stück Quantity Quantités Cantidades			Hinweise Hints Indications Indicaciones	
		2 M...	3 M...	4 M...		
1	500 035 00	6	9	12	B 8	DIN 137
2	031 687 01	0...2	0...3	0...4	0,30 mm	
3	038 971 00	0...2	0...3	0...4	0,60 mm	
4	038 972 00	0...2	0...3	0...4	0,90 mm	
5	038 973 00	0...2	0...3	0...4	1,20 mm	
6	502 630 01	2	3	4		
7	500 229 00 P4	9	14	19	M 8	DIN 934-8
8	400 850 00	2	3	4		
9	401 209 01	2	3	4		
10	—	—	—	—		
11	501 413 01 P1	2	3	4		
12	034 665 00	2	3	4		
13	034 605 00	2	3	4		
14	501 282 00 P4	4	6	8	8	DIN 127
15	012 038 00	2	3	4	„L“	
16	007 406 00	2	3	4	„H“	
17	038 968 00	0...4	0...6	0...8	0,20 mm	
18	038 969 00	0...4	0...6	0...8	0,30 mm	
19	502 676 00	1	1	1	M 8	DIN 1587

M 16

Riemenscheibe  
Pulley  
Poulie  
Polea

M 17

Schwungrad  
Flywheel  
Volant  
Volante

M 20

Hydr. Abstellschr.  
Hydr. belt tensioner  
Tendeur hydr.  
Tensor hidr.

Tafel Nr.  
Tabl. No.  
14

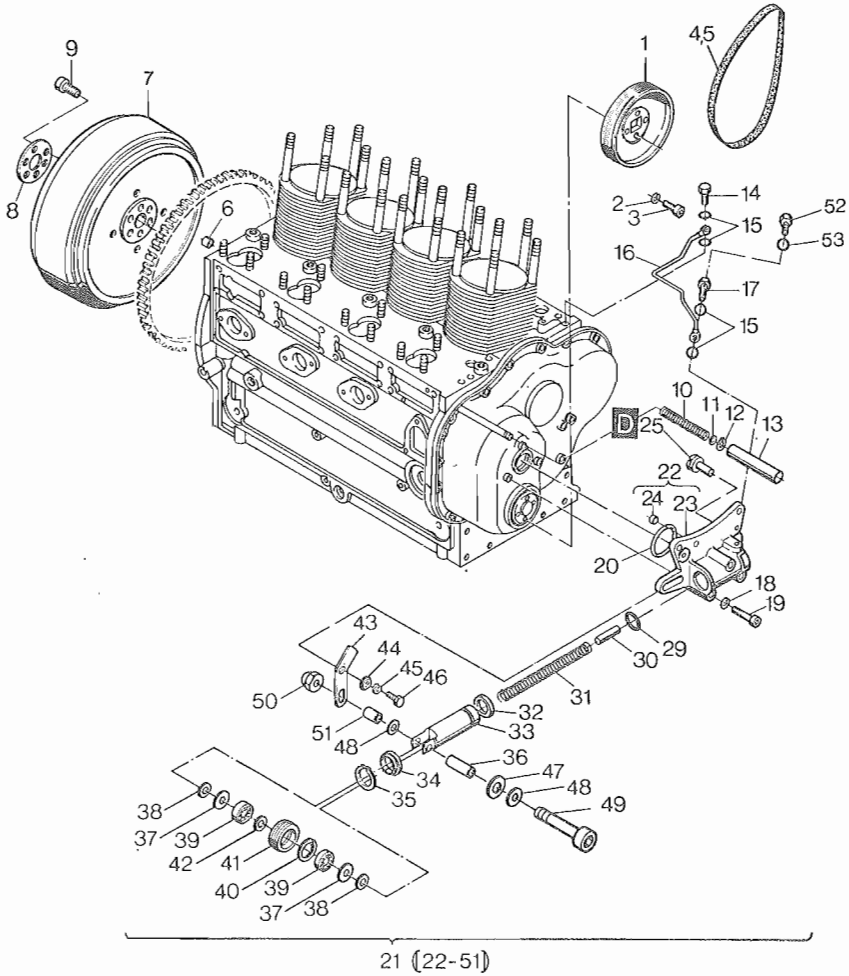

Fig. No.	Bestell-Nr. Ordering No. No. référence No. de pedido	Stück Quantity Quantités Cantidades	Hinweise Hints Indications Indicaciones	
2... 4M...				
1	035 898 01	1		
2	501 282 00	4	8	DIN 127
3	500 519 00	4	M 8x20	DIN 931-8.8
4	501 415 00 P1	1		9 J 910
5	—	—		
6	036 306 00	1		
7	037 337 01	1	SAE J620	
8	036 458 00	1		
9	502 251 00	6	M 14x1,5 45	DIN 912-10.9
10	034 680 00	1		
11	031 332 00	1		
12	500 194 00	1	8x0,8	DIN 471
13	035 682 00	1		
14	500 061 00	1	A 2/3	DIN 7623
15	500 009 00	4	A 8x11,5	DIN 7603-Cu
16	009 100 00	1		
17	037 248 00	1		
18	500 035 00	3	B 8	DIN 137
19	500 818 00	3	M 8x65	DIN 912-8.8
20	501 324 01	1		
21	009 414 04	1		
22	009 276 30	1		
23	—	—		
24	400 847 00	1		
25	037 506 00	1		
26	—	—		
27	—	—		
28	—	—		
29	502 197 00	1		
30	036 393 00	1		
31	035 891 00	1		
32	502 211 00	1		
33	035 896 21	1		
34	036 430 01	1		
35	502 904 00	1	45x1,75	
36	037 646 00	1		

M 16

Riemenscheibe  
Pulley  
Poulie  
Polea

M 17

Schwungrad  
Flywheel  
Volant  
Volante

M 20

Hydr. Abstellvorr.  
Hydr. belt tensioner  
Tendeur hydr.  
Tensor hidr.

Tafel Nr.  
Tabl. No.  
14

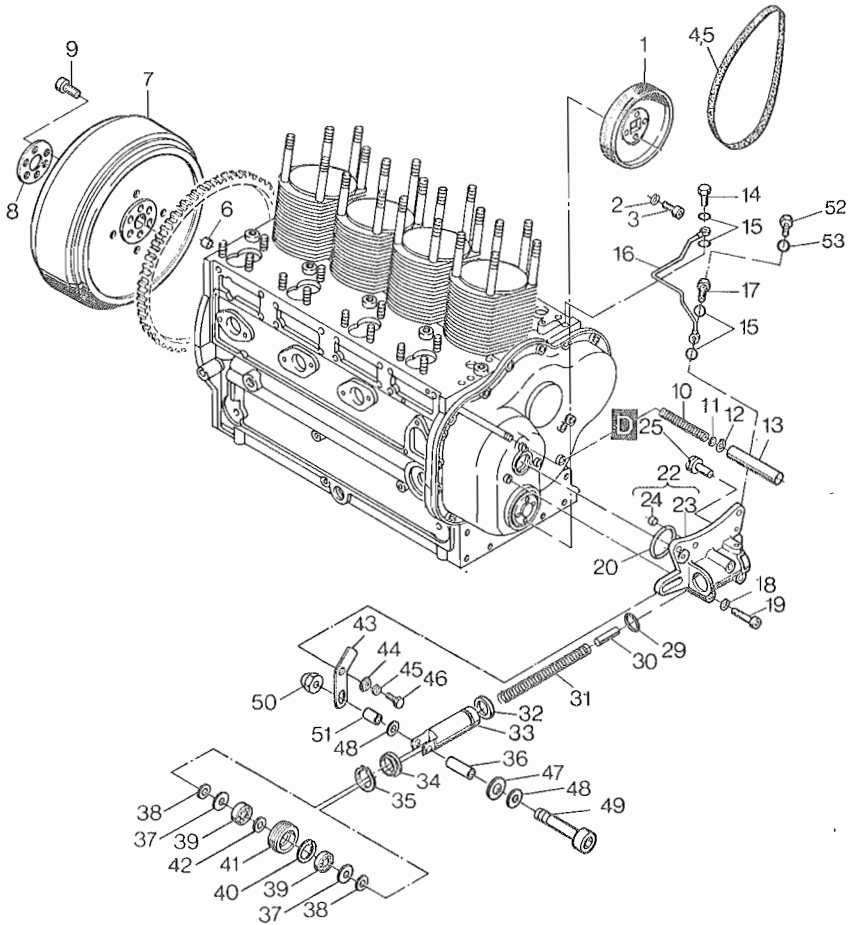

21 (22-51)

Fig. No.	Bestell-Nr. Ordering No. No. référence No. de pedido	Stück Quantity Quantites Cantidades	Hinweise Hints Indications Indicaciones	
2... 4M...				
37	502 500 00	2		
38	037 648 00	2		
39	502 499 00	2		
40	500 207 00	1	28x1,2	DIN 472
41	035 894 20	1		
42	501 321 00	1	12x18x1,2	
43	035 895 10	1		
44	035 893 00	1		
45	500 027 00	1	6	DIN 128
46	500 258 00	1	M 6x20	DIN 933-8.8
47	037 649 00	1		
48	500 167 00	2	A 8,4	DIN 125 St
49	500 818 00	1	M 8x65	DIN 912-8.8
50	400 284 00	1	M 8	SSN 440-8 Cu
51	037 647 00	1		
52	500 253 00	1	M 6x8	DIN 933-8.8
53	500 008 00	1	A 6,5x9,5	DIN 7603-Cu

M 22

Luftfilter  
Air filter  
Filtre à air  
Filtro de aire

M 27

Luftansaugrohr  
Air intake manifold  
Collecteur d'admission  
Tubo de aspiración

Tafel Nr.  
Tabl. No.

15

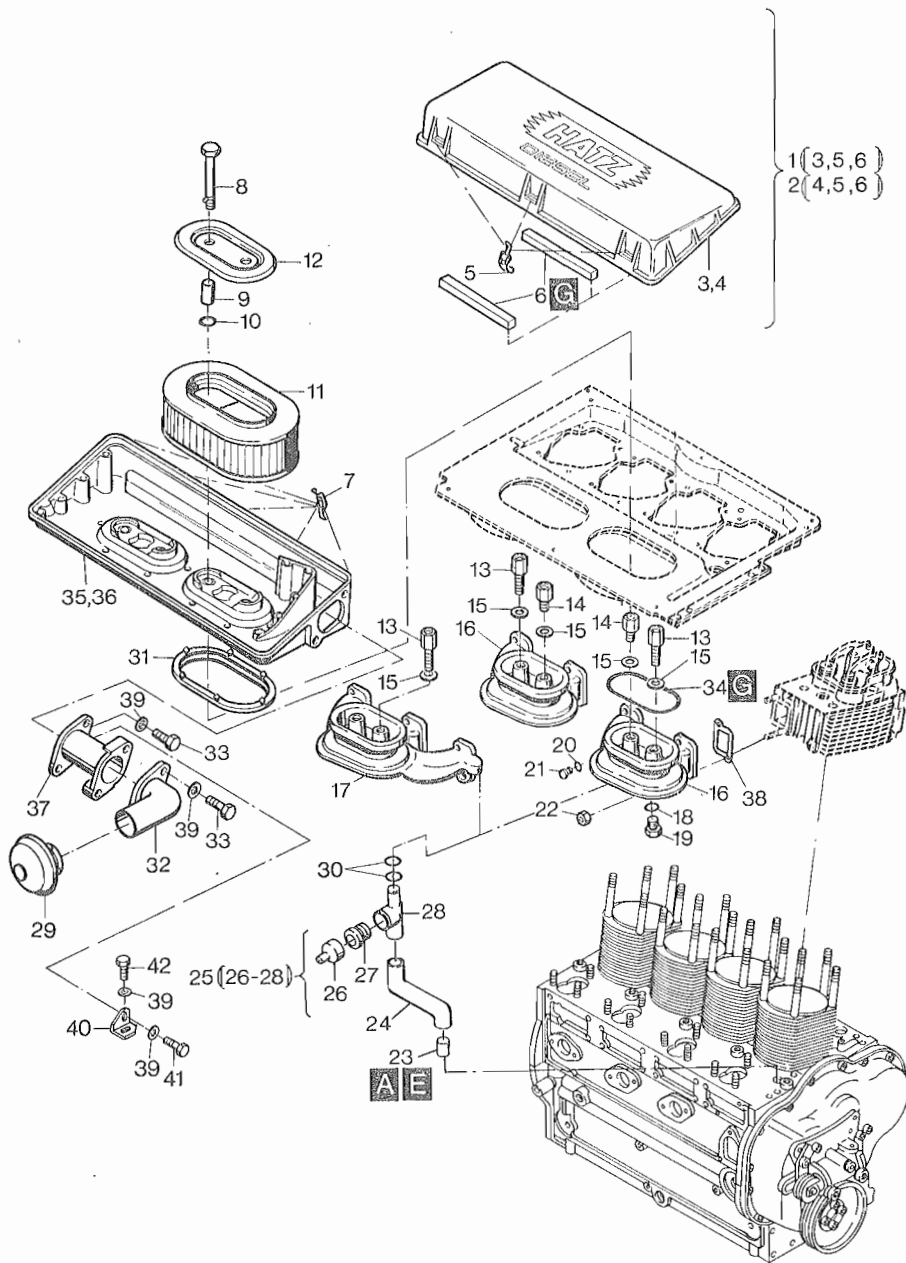

Fig. No.	Bestell-Nr. Ordering No. No. référence No. de pedido	Stück Quantity Quantites Cantidades			Hinweise Hints Indications Indicaciones
		2 M...	3 M...	4 M...	
1	012 178 00	1	1	—	
2	012 180 00	—	—	1	
3	—	—	—	—	
4	—	—	—	—	
5	012 078 00 P2	2	2	3	
6	037 789 00	2	2	4	
7	012 078 00	3	3	5	
8	037 790 01	2	2	4	
9	037 801 00	2	2	4	
10	400 221 00	2	2	4	
11	009 529 00 W2/4	1	1	2	
12	012 126 00	1	1	2	
13	037 787 00	2	2	2	
14	037 786 00	—	—	2	
15	031 717 00	2	2	4	
16	037 754 01	1	—	2	
17	037 755 00	—	1	—	
18	500 016 00	1	1	2	A 22x27    DIN 7603-Cu
19	501 404 00	1	1	2	AM 22x1,5    DIN 7604
20	500 624 00	1	1	2	A 10x13,5    DIN 7603-Cu
21	500 623 00	1	1	2	M 10x1        DIN 908
22	502 236 00 P4	4	6	8	M 8            A3C
23	036 490 00	1	1	1	
24	036 489 00	1	1	1	
25	009 478 01	1	1	1	
26	035 686 00	1	1	1	
27	035 687 00	1	1	1	
28	—	—	—	—	
29	502 879 00 P1	1	1	1	
30	503 267 00	2	2	2	9,7x1
31	037 791 00	1	1	2	
32	037 751 00	1	1	1	
33	501 482 00	2	4	2	M 8x22        DIN 933-8.8 A3C
34	037 788 00	1	1	2	
35	012 079 00	1	1	—	
36	012 073 00	—	—	1	





Fig. No.	Bestell-Nr.	Stück			Hinweise	
	Ordering No.	Quantity	Quantity	Quantity	Hints	Hints
	No. référence	Quantities	Quantities	Quantities	Indications	Indications
	No. de pedido	Cantidades	Cantidades	Cantidades	Indicaciones	Indicaciones
		2 M...	3 M...	4 M...		
37	012 115 00	—	1	—		
38	036 244 00	2	3	4		
39	501 481 00	2	6	2	8,4	DIN 125-St A3C
40	037 757 00	—	1	—		
41	500 985 00	—	1	—	M 8x16	DIN 933-8.8 A3C
42	501 354 00	—	1	—	M 8x20	DIN 933-8.8 A3C

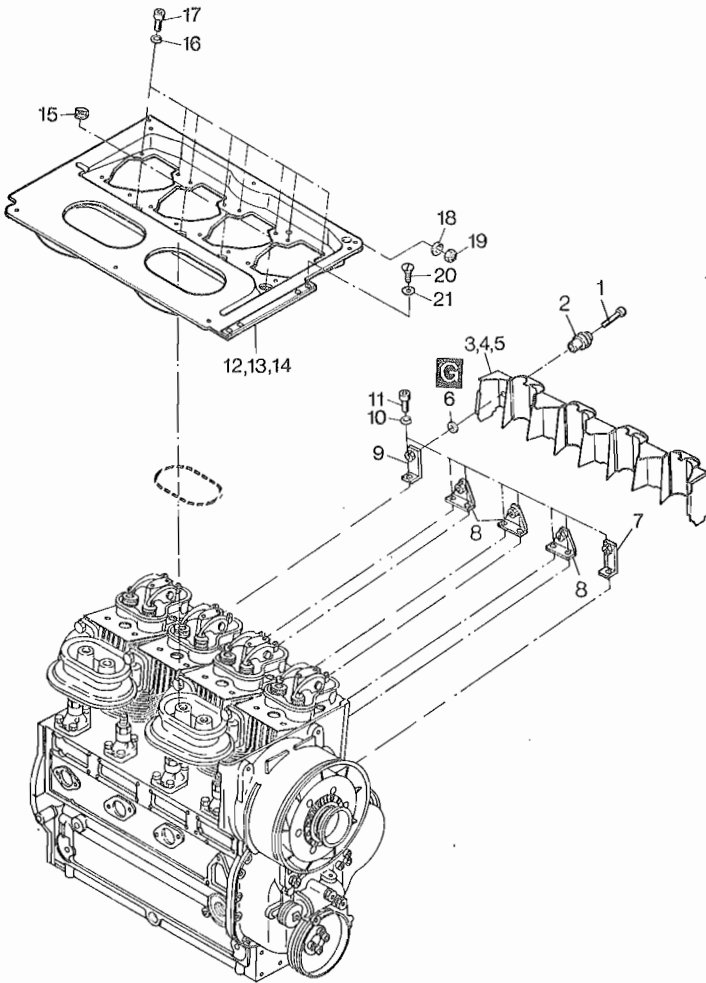

Fig. No.	Bestell-Nr. Ordering No. No. référence No. de pedido	Stück Quantity Quantites Cantidades			Hinweise Hints Indications Indicaciones	
		2 M...	3 M...	4 M...		
1	500 511 00	3	4	5	M 6x30	DIN 6912-8.8
2	009 327 00	3	4	5		
3	009 380 00	1	—	—		
4	009 381 00	—	1	—		
5	009 382 00	—	—	1		
6	035 755 00	3	4	5		
7	009 235 00	1	1	1		
8	009 233 00	1	2	3		
9	009 234 00	1	1	1		
10	500 028 00	4	6	8	8	DIN 128
11	500 516 00	8	8	8	M 8x16	DIN 912-8.8
12	012 117 00	1	—	—		
13	012 118 00	—	1	—		
14	012 119 00	—	—	1		
15	035 927 00 P2	2	3	4		
16	500 812 00 P4	4	6	8	A 6	DIN 137
17	500 507 00 P4	4	6	8	M 6x16	DIN 912-8.8
18	500 027 00 P3	3	3	3	6	DIN 128
19	500 227 00 P3	3	3	3	M 6	DIN 934-8
20	502 052 00 P4	4	4	4	M 8x16	DIN 965-8.8
21	502 051 00 P4	4	3	4	V 8,4	DIN 6797

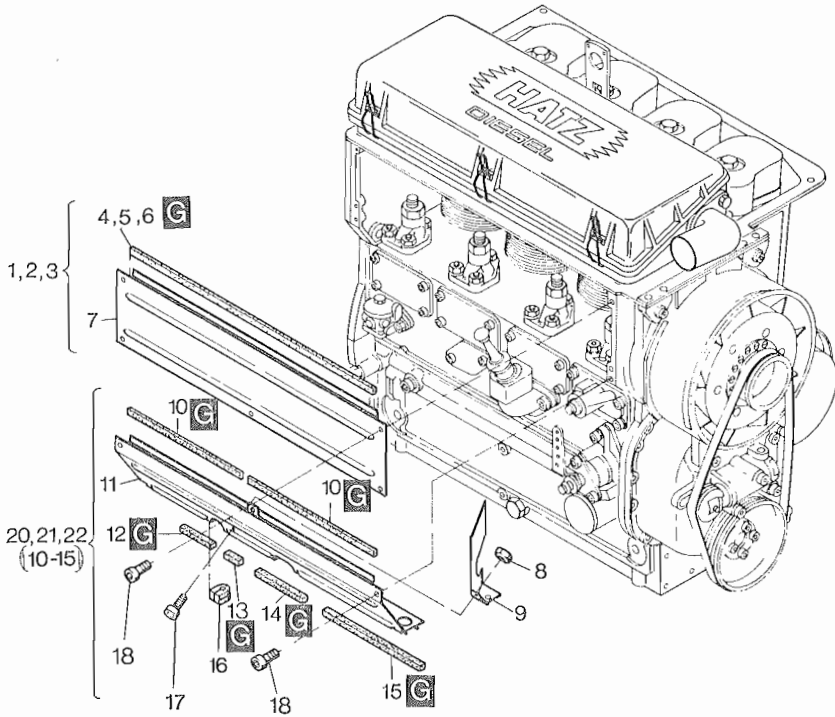

Fig. No.	Bestell-Nr. Ordering No. No. référence No. de pedido	Stück Quantity Quantites Cantidades			Hinweise Hints Indications Indicaciones
		2 M...	3 M...	4 M...	
1	007 427 00	1	—	—	
2	007 426 00	—	1	—	
3	007 451 01	—	—	1	
4	035 640 00	1	—	—	231 mm
5	035 631 00	—	1	—	366 mm
6	035 700 00	—	—	1	501 mm
7	—	—	—	—	
8	500 227 00	—	—	3	M 6
9	036 018 00	—	—	1	DIN 934-8
10	035 640 00	1	—	—	231 mm
10	035 636 00	—	2	—	173 mm
10	035 726 00	—	—	2	240 mm
11	—	—	—	—	
12	035 638 00	—	1	1	67 mm
13	035 990 00	—	—	1	30 mm
14	035 987 00	1	—	—	47 mm
14	035 985 00	—	1	—	32 mm
14	035 725 01	—	—	1	97 mm
15	035 644 01	1	—	—	128 mm
15	035 637 01	—	1	1	214 mm
16	035 689 00	1	1	1	
17	503 410 00	—	—	3	M 6x13
18	503 410 00	6	8	8	M 6x13
19	—	—	—	—	
20	007 429 11	1	—	—	} s. Taf./Tabl. 30, Pos. 8-13 n ≤ 1500 min <sup>-1</sup>
21	007 428 11	—	1	—	
22	007 462 11	—	—	1	

**M 26**

Luftführung  
Air ducting  
Carter ventilation  
Conducción de aire

Tafel Nr.  
Tabl. No.

18

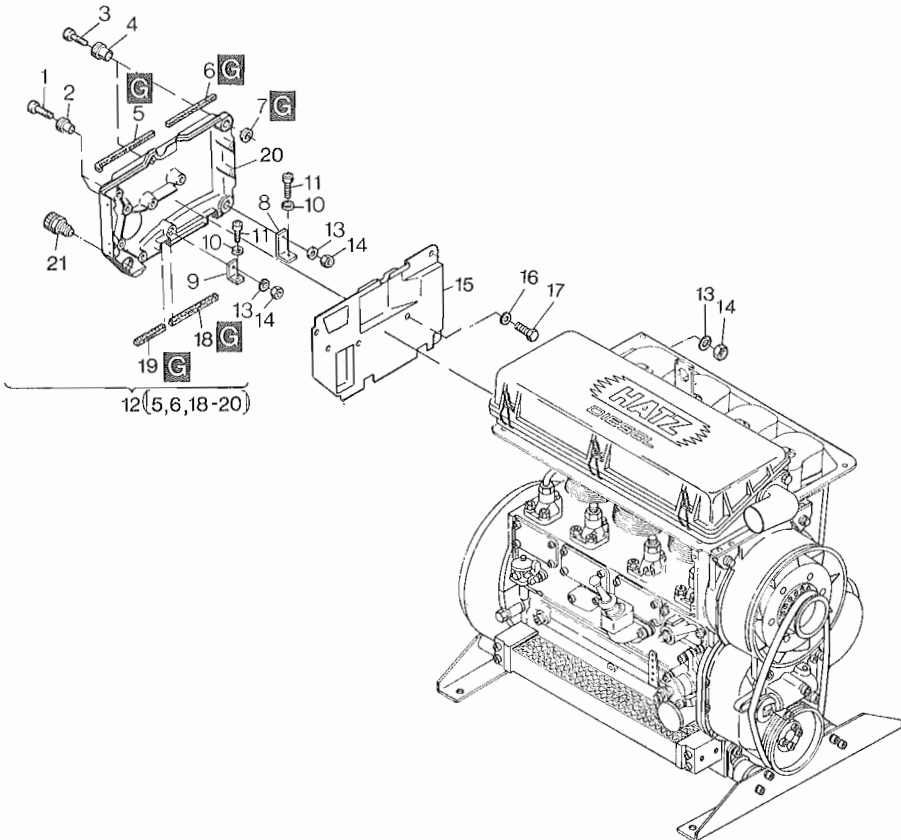

Fig. No.	Bestell-Nr. Ordering No. No. référence No. de pedido	Stück Quantity Quantites Cantidades	Hinweise Hints Indications Indicaciones	
2... 4 M...				
1	500 510 00	2	M 6x30	DIN 912-8.8
2	009 327 00	2		
3	500 511 00	2	M 6x30	DIN 912-8.8
4	009 215 00	2		
5	035 637 01	1	214 mm	
6	035 651 00	1	113 mm	
7	035 755 00	4		
8	036 468 00	1		
9	036 469 00	1		
10	500 028 00	2	8	DIN 128
11	500 516 00	2	M 8x16	DIN 912-8.8
12	012 164 00	1		
13	500 812 00	4	A 6	DIN 137
14	500 227 00	4	M 6	DIN 933-8.8
15	036 462 01	1		
16	500 812 00	7	A 6	DIN 137
17	500 255 00	7	6x12	DIN 933-8.8
18	035 651 00	1	113 mm	
19	035 602 00	1	93 mm	
20	—	—		
21	501 590 10	1		





Fig. No.	Bestell-Nr. Ordering No. No. référence No. de pedido	Stück Quantity Quantities Cantidades			Hinweise Hints Indications Indicaciones	
		2 M...	3 M...	4 M...		
1	502 515 00 W2	1	1	1		
2	501 299 00	1	1	1		
3	401 204 00	1	1	1	IMSA	
4	500 812 00	2	2	2	A 6	DIN 137
5	500 227 00	2	2	2	M 6	DIN 934-8
6	500 012 00	3	3	3	A 14x18	DIN 7603-Cu
7	034 668 00	1	1	1		
8	034 933 00	1	1	1		
9	400 373 00	2	2	2		
10	503 170 00 W2	1	1	1		
11	034 602 00	2	3	4		
12	035 733 01	1	1	1		
13	500 064 00	1	1	1	10-3	DIN 7643
14	500 011 00	9	11	13	A 12x15,5	DIN 7603-Cu
15	038 365 00	1	—	—		
16	038 366 00	—	1	—		
17	038 367 00	—	—	1		
18	036 134 00	1	2	2		
19	500 063 00	2	2	2	8-13	DIN 7643
20	500 009 00	4	6	8	A 8x11,5	DIN 7603-Cu
21	036 397 00	1	1	—		
21	038 906 00	—	—	1		
22	500 008 00	2	3	4	A 6,5x9,5	DIN 7603-Cu
23	035 739 00	2	3	4		
24	502 533 00	1	1	1	A LL 10	DIN 7647
25	500 012 00	1	1	1	A 14x18	DIN 7603-Cu
26	—	—	—	—		
27	—	—	—	—		
28	490 184 00	1	1	1	Pierburg	
29	—	—	—	—		
30	490 181 00	6	6	6	Pierburg	
31	—	—	—	—		
32	—	—	—	—		
33	—	—	—	—		
34	490 183 00	1	1	1	Pierburg	
35	490 185 00	1	1	1	Pierburg	
36	490 182 00	1	1	1	Pierburg	
37	490 606 00	1	1	1	IMSA	
38	008 063 00	1	—	—		
39	008 061 00	—	1	—		
40	008 060 00	—	—	1		

**A 01**

Kraftstoffbehälter  
Fuel tank  
Reservoir à carburant  
Depósito combustible

Tafel Nr.  
Tabl. No.

20

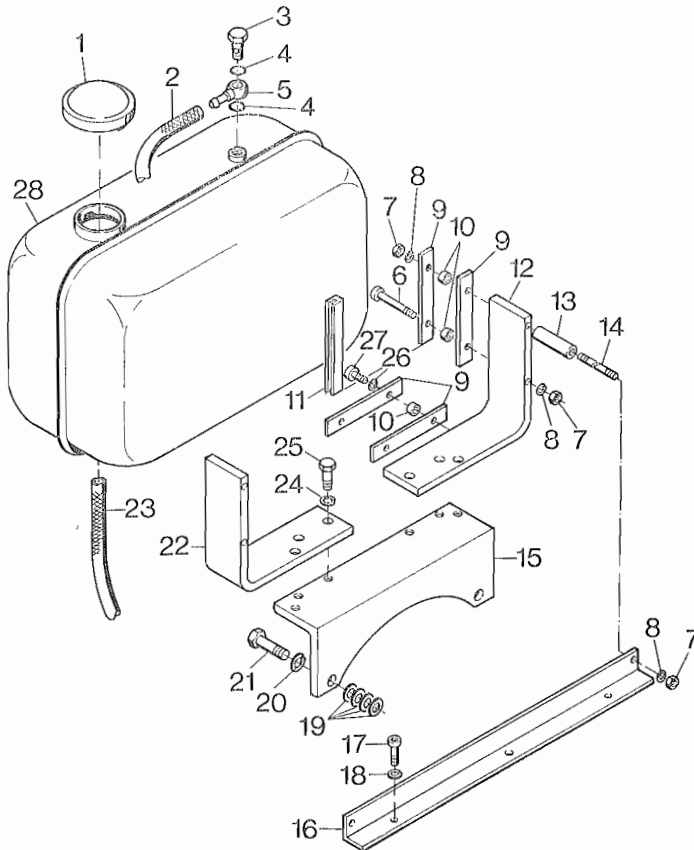

Fig. No.	Bestell-Nr. Ordering No. No. référence No. de pedido	Stück Quantity Quantities Cantidades	Hinweise Hints Indications Indicaciones
2... 4 M...			
1	400 327 00	1	
2	038 816 00	1	4,5x200
3	500 061 00	1	4-5-3      DIN 7643
4	500 009 00	2	A 8x11,5      DIN 7603-Cu
5	500 157 00	1	
6	501 209 00	2	M 8x85      DIN 912-8.8 A3C
7	501 480 00	9	M 8      DIN 934-8 A3C
8	502 085 00	6	8      DIN 128-A3C
9	038 870 00	8	
10	039 158 00	8	8,5x11x7
11	038 871 00	4	
12	038 865 00	1	
13	039 159 00	2	9x13x42,6
14	501 294 00	2	M 8x140      DIN 835-8.8 A3C
15	038 864 00	1	
16	038 869 00	1	
17	502 063 00	3	M 8x18      DIN 912-8.8 A3C
18	502 085 00	3	8      DIN 128 A3C
19	500 174 00	8	15      DIN 433 St
20	502 599 00	2	14      DIN 128-A3C
21	501 769 00	2	M 14x1,5x65      DIN 960-8.8 A3C
22	038 866 00	1	
23	034 935 00	1	7x200
24	501 356 00	6	10      DIN 128-A3C
25	501 364 00	6	M 10x25      DIN 933-8.8 A3C
26	502 085 00	4	8      DIN 128-A3C
27	501 759 00	4	M 8x30      DIN 912-8.8 A3C
28	010 992 00	1	

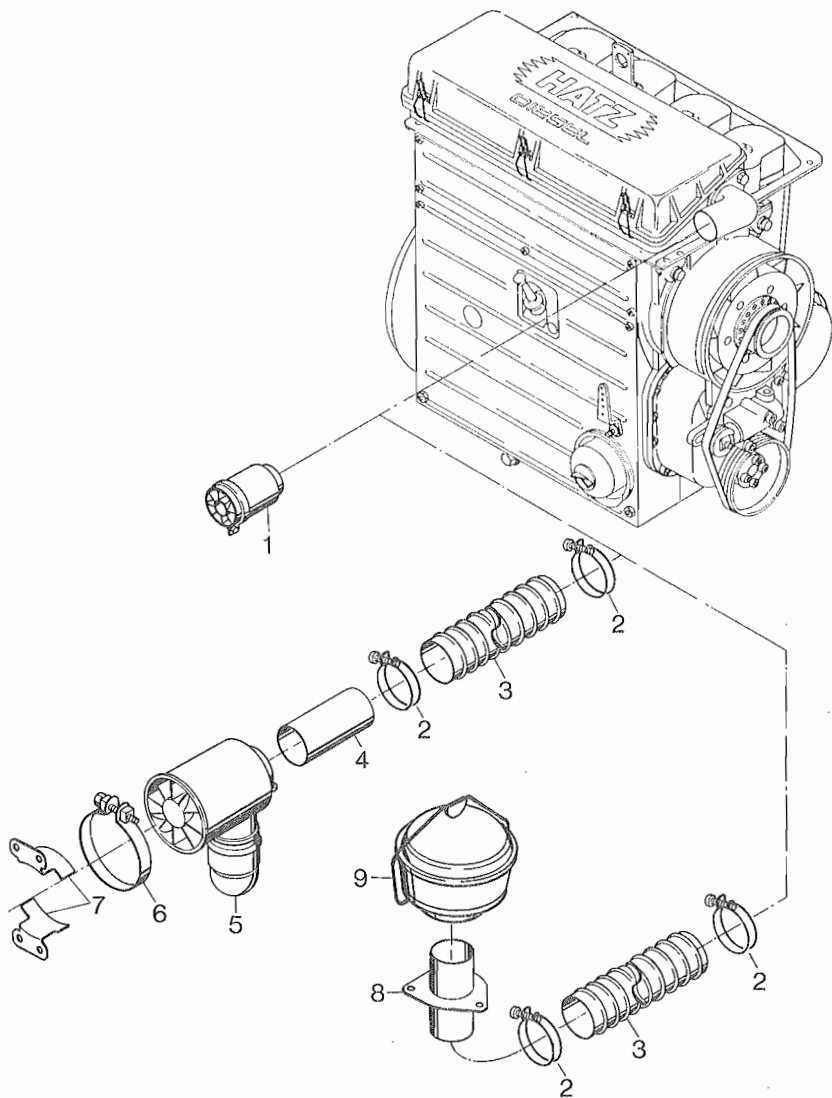

Fig. No.	Bestell-Nr. Ordering No. No. référence No. de pedido	Hinweise Hints Indications Indicaciones	Stück Quantity Quantites Cantidades
		2... 4 M...	
1	012 160 00	1	
2	501 973 00	2	64/73
3	039 053 00	1...4	1 m
4	038 205 00	1	
5	400 353 00	1	
6	400 291 00	1	
7	038 208 00	2	
8	010 271 00	1	
9	501 961 00	1	

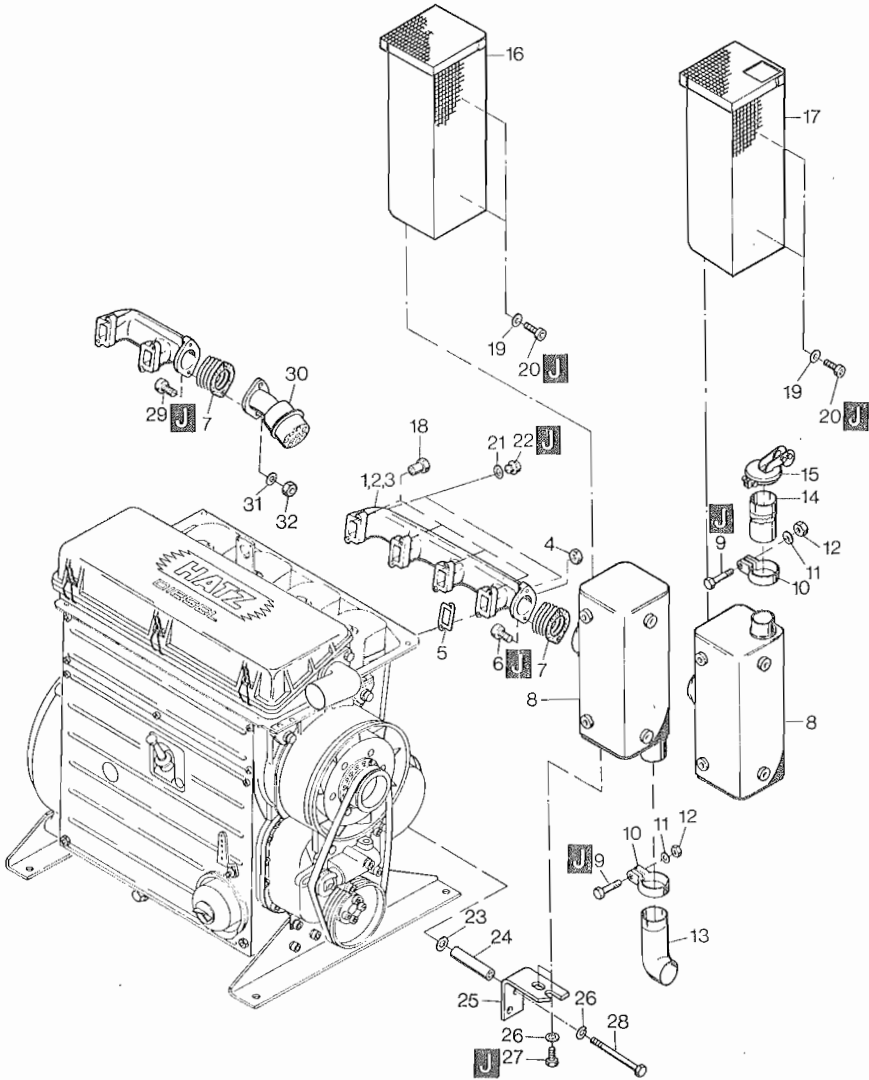

Fig. No.	Bestell-Nr. Ordering No. No. référence No. de pedido	Stück Quantity Quantites Cantidades			Hinweise Hints Indications Indicaciones	
		2 M...	3 M...	4 M...		
1	036 251 00	1	—	—		
2	036 319 00	—	1	—		
3	036 320 00	—	—	1		
4	400 284 00 P2	2	3	4	M 8	SSN 440-8 Cu
5	036 245 00	2	3	4		
6	502 250 00	2	2	2	M 10x30	DIN 912-10.9 C4P
7	501 659 01	5	5	5		
8	011 091 00	1	1	1		
9	500 301 00	1	1	1	M 10x65	DIN 931-8.8
10	038 778 00	1	1	1		
11	501 459 00	1	1	1	10,5	DIN 125-St A3C
12	400 286 00	1	1	1	M 10	SSN 440-8 Cu
13	038 856 00	1	1	1		
14	038 896 00	1	1	1		
15	501 569 00	1	1	1		
16	010 914 00	1	1	1		
17	038 858 00	1	1	1		
18	036 252 00 P2	2	3	4		
19	501 200 00	6	6	6	A 6,4	DIN 9021-St A3C
20	501 390 00	6	6	6	M 6x10	DIN 912-8.8 C4P
21	032 288 00	2	3	4		
22	500 447 00	2	3	4	R 1/4	DIN 910
23	500 629 00	2	2	2	8,4	DIN 9021-St A3C
24	035 387 01	2	2	2	9x14x42	
25	039 229 00	1	1	1		
26	501 481 00	4	4	4	8,4	DIN 125-St A3C
27	501 376 00	2	2	2	M 8x20	DIN 933-8.8 C4P
28	500 879 00	2	2	2	M 8x70	DIN 931-8.8
29	500 326 00	2	—	—	M 10x40	DIN 933-8.8 C4P
30	008 723 00	1	—	—	$n \leq 2300 \text{ min}^{-1}$	
31	501 356 00	2	—	—	10	DIN 128 A3C
32	400 286 00	2	—	—	M 10	SSN 440-8 Cu



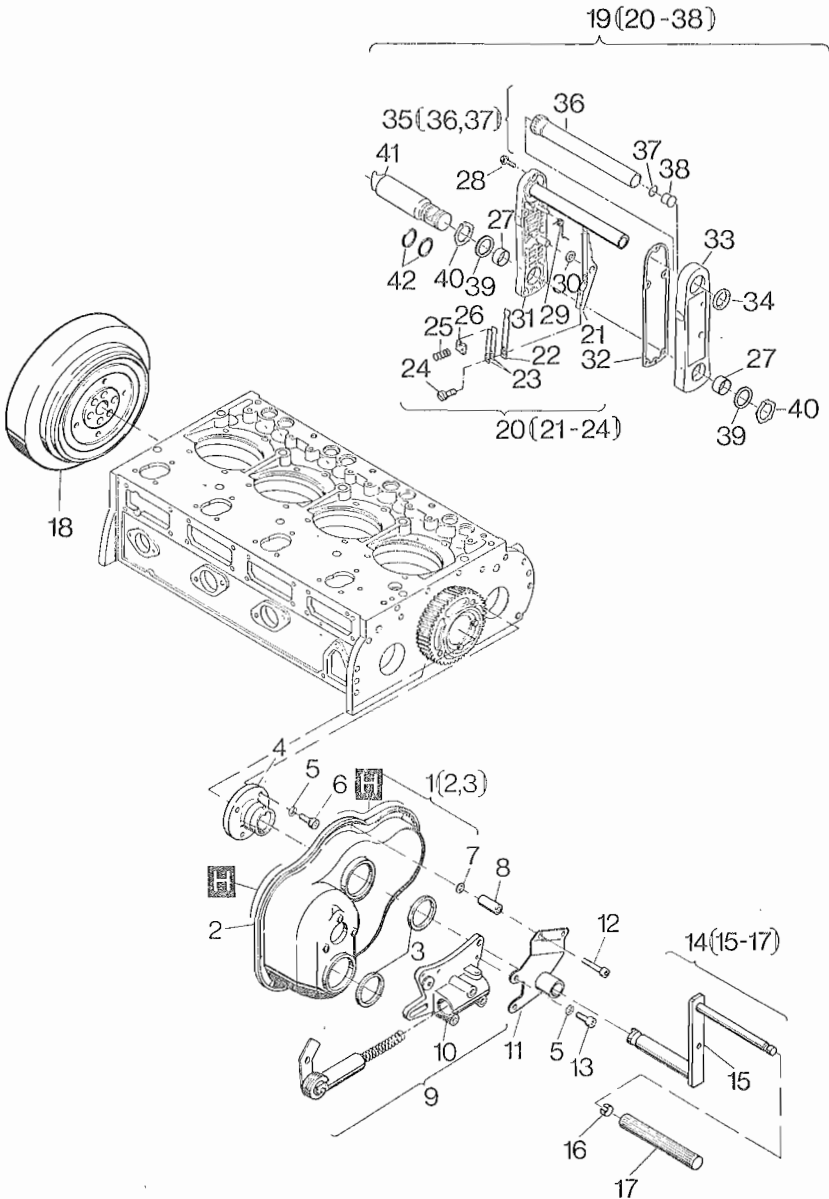

Fig. No.	Bestell-Nr. Ordering No. No. référence No. de pedido	Stück Quantity Quantities Cantidades	Hinweise Hints Indications Indicaciones	
2...4 M				
1	009 954 00	1		
2	—	—		
3	501 291 00	2	55x70x8	
4	009 916 00	1		
5	500 028 00	6	8	DIN 128
6	500 520 00	4	M 8x20	DIN 6912-8.8
7	500 167 00	2	8,4	DIN 125 St
8	035 387 01	2		
9	009 955 01	1		
10	037 645 10	1		
11	009 951 00	1		
12	500 818 00	2	M 8x65	DIN 912-8.8
13	500 520 00	2	M 8x20	DIN 6912-8.8
14	009 950 00	1		
15	—	—		
16	035 154 00	1		
17	035 224 00	1		
18	038 469 00	1		
19	010 278 04	1	„A“	
20	010 114 03	1		
21	—	—		
22	038 121 02	1		
23	039 171 00	2		
24	503 165 00	2	M 5x8	DIN 6912-8.8
25	038 184 00	1		
26	038 820 00	1		
27	501 934 00	2		
28	501 944 00	5	M 6x25	DIN 6912-8.8 A3C
29	038 784 00	1	„A“	
30	501 958 00	1	10x16x0,5	DIN 988
31	—	—		
32	038 130 00	1		
33	—	—		
34	501 942 00	1	28x35x4	
35	010 113 10	1		
36	—	—		

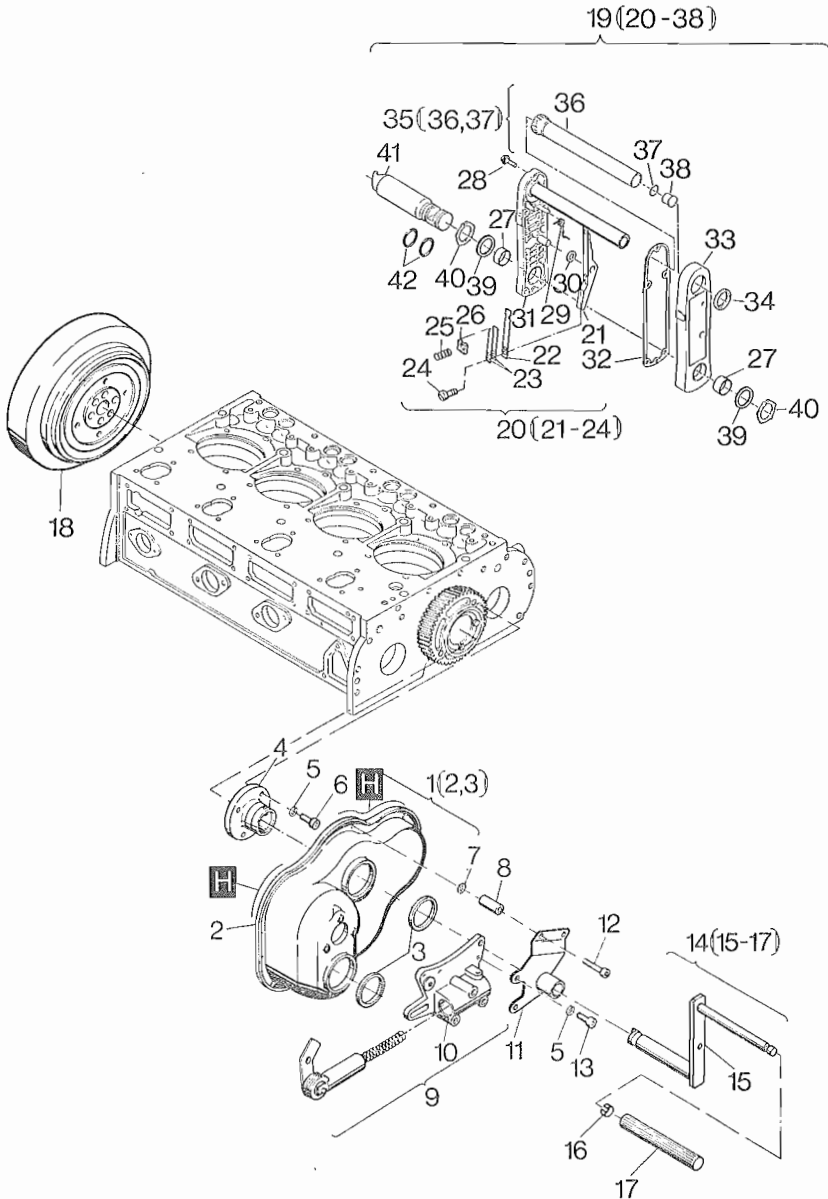

Fig. No.	Bestell-Nr. Ordering No. No. référence No. de pedido	Stück Quantity Quantites Cantidades	Hinweise Hints Indications Indicaciones	
		2... 4 M		
37	501 691 00	1	19x1,8	DIN 769
38	501 992 00	1	V 18	
39	039 286 00	0... 2	30x38x0,15	
40	501 943 00	2	A 30x1,5 K	DIN 983
41	010 399 00	1	192 mm	
42	502 585 00	2	26x1,5	

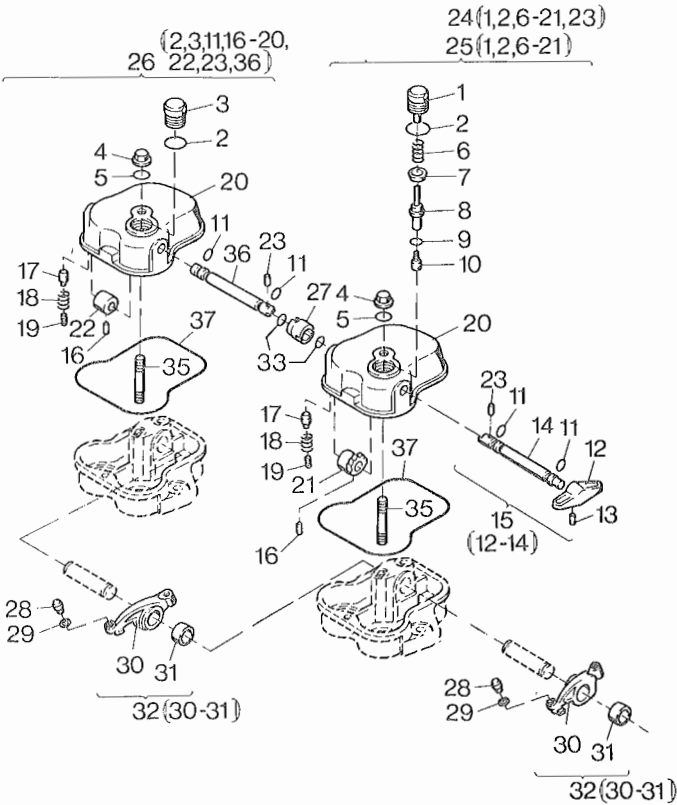

Fig. No.	Bestell-Nr. Ordering No. No. référence No. de pedido	Quantity Stück Quantites Cantidades			Hinweise Hints Indications Indicaciones	
		2 M...	3 M...	4 M...		
1	009 946 00	1	3	4		
2	500 016 00	2	3	4	A 22x27	DIN 7603-Cu
3	037 656 00	1	3	4		
4	502 484 00	2	3	4	M 10-6	DIN 986
5	502 485 00	2	3	4		
6	031 887 00	1	3	4		
7	037 721 00	1	3	4		
8	037 629 00	1	3	4		
9	037 632 00	0...6	0...18	0...24		
10	037 627 00	1	3	4		
11	400 223 00	4	6	8		
12	037 782 00	1	3	4		
13	500 346 00	1	3	4	4x18	DIN 1481
14	—	—	—	—		
15	012 065 00	1	—	—		
15	012 146 00	—	3	4		
16	500 341 00	2	3	4	3x16	DIN 1481
17	037 601 00	2	3	4		
18	037 597 00	2	3	4		
19	500 650 00	2	3	4	AM 10x10	TUF-LOK DIN 913
20	037 593 10	2	3	4		
21	037 599 11	1	3	4		
22	037 603 10	1	—	—		
23	502 486 00	2	—	—	4x20	DIN 7343
24	009 880 10	1	—	—		
25	012 145 00	—	3	4		
26	009 881 10	1	—	—		
27	037 607 00	1	—	—		
28	034 519 00	2	3	4		
29	501 232 00	0...8	0...12	0...16	5x10x0,5	DIN 988
30	—	—	—	—		
31	031 841 00	2	3	4		
32	005 326 02	2	3	4		
33	502 573 00	2	—	—	12x2,5	
34	—	—	—	—		
35	502 482 00	2	3	4	M 10x60	DIN 939-8.8
36	037 602 10	1	—	—		
37	502 544 00	2	3	4	120,32x2,62	

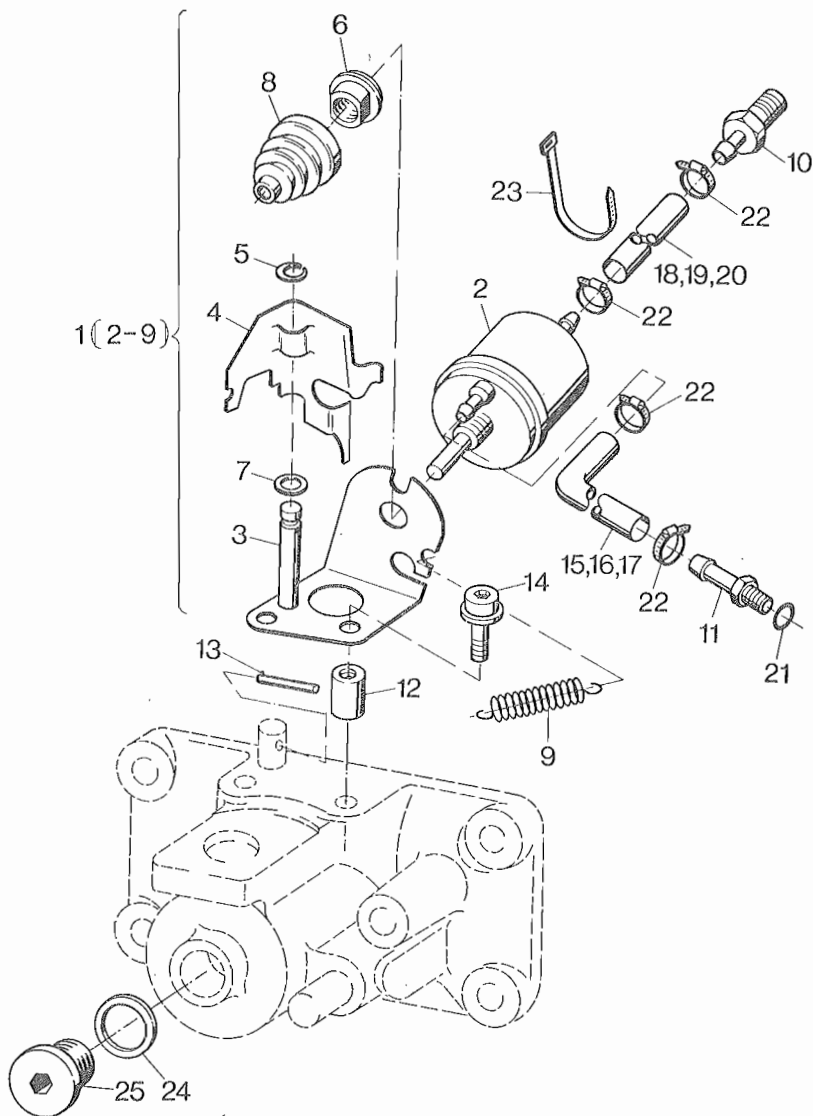

Fig. No.	Bestell-Nr. Ordering No. No. référence No. de pedido	Stück Quantity Quantites Cantidades			Hinweise Hints Indications Indicaciones	
		2 M...	3 M...	4 M...		
1	011 232 00	1	1	1		
2	011 059 00	1	1	1		
3	011 060 00	1	1	1		
4	038 985 00	1	1	1		
5	501 172 00	1	1	1	4	DIN 6799
6	039 220 00	1	1	1		
7	—	—	—	—		
8	501 445 00	1	1	1	6,4	DIN 125-St A3C
9	502 860 00	1	1	1		
10	011 061 00	1	1	1		
11	038 978 00	1	1	1		
12	039 219 00	2	2	2	7x14x12	
13	500 343 00	1	1	1	3x36	DIN 1481
14	501 944 00	2	2	2	M 6x25	A3C
15	038 992 00	1	—	—	270 mm	
16	039 020 00	—	1	—	390 mm	
17	039 021 00	—	—	1	540 mm	
18	038 993 00	1	—	—	400 mm	
19	039 021 00	—	1	—	540 mm	
20	039 022 00	—	—	1	640 mm	
21	503 167 00	1	1	1		
22	400 934 00	4	4	4		
23	501 674 00	1	2	3		
24	500 012 00	1	1	1	14x18	DIN 7603-Cu
25	501 435 00	1	1	1	M 14x1,5	DIN 908



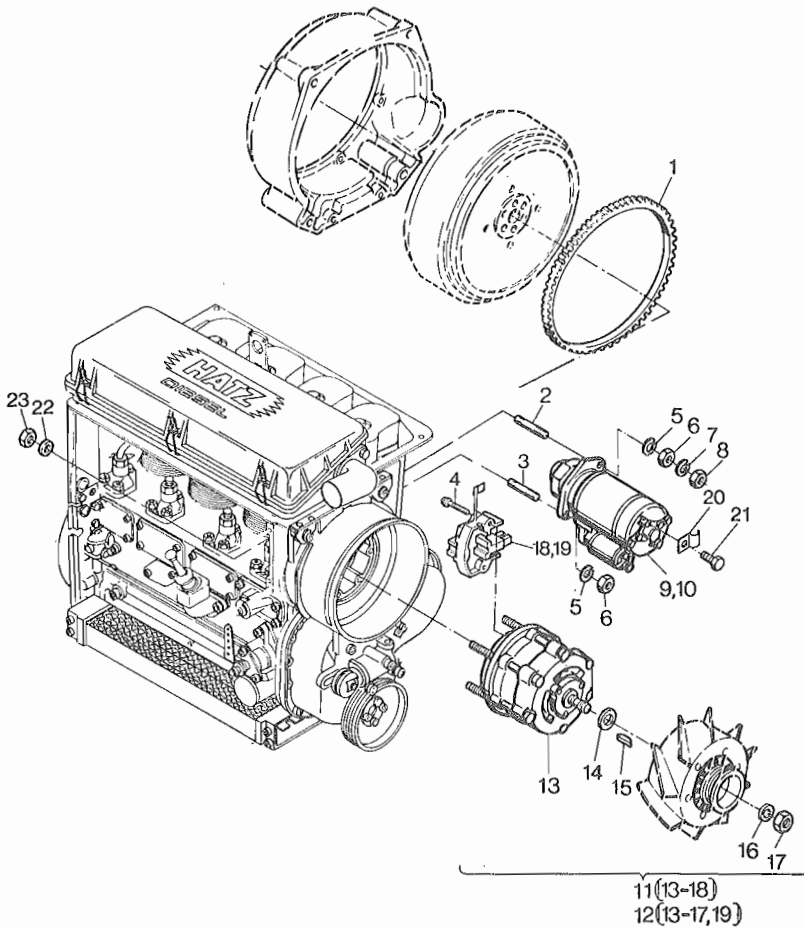

Fig. No.	Bestell-Nr. Ordering No. No. référence No. de pedido	Stück Quantity Quantites Cantidades	Hinweise Hints Indications Indicaciones	
2... 4 M...				
1	031 561 01	1		
2	032 868 00	1		
3	500 423 00	1	M 12x25	DIN 938-5.6
4	—	—		
5	500 030 00	2	12	DIN 128
6	500 239 00	2	M 12	DIN 934-8
7	500 632 00	1	12	
8	500 635 00	1	M 12	DIN 936-5 GAL
9	501 835 00	1	12 V	2,7 kW
10	501 954 00	1	24 V	4,0 kW
11	401 210 01	1	14 V	50 A
12	501 649 01	1	28 V	40 A
13	—	—		
14	—	—		
15	500 178 00	1	4x6,5	DIN 6888
16	—	—		
17	490 536 00	1		
18	490 538 00	1	12 V	
19	490 539 00	1	24 V	
20	501 584 00	1		
21	501 655 00	1	M 6x12	DIN 933-8.8 A3C
22	500 812 00	6	A 6	DIN 137 A3C
23	501 444 00	6	M 6	DIN 934-8 A3C

1 (3-18, 20, 23-26, 28-41, 43, 45, 46)  
2 (3-18, 20, 23-25, 27-40, 42, 44-46)

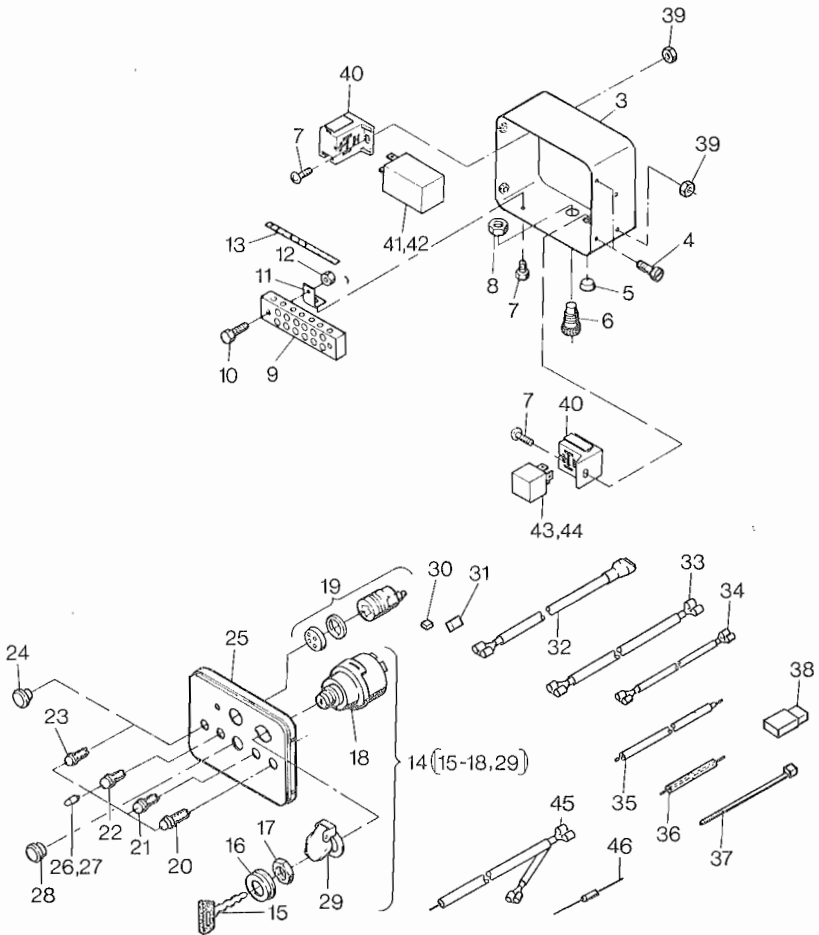

Fig. No.	Bestell-Nr. Ordering No. No. référence No. de pedido	Stück Quantity Quantities Cantidades			Hinweise Hints Indications Indicaciones
		2 M...	3 M...	4 M...	
1	008 262 04	1	1	1	12 V
2	008 236 04	1	1	1	24 V
3	007 163 11	1	1	1	
4	502 892 00	4	4	4	M 6x12 SB-8.8 A3D
5	501 608 00	2	2	2	
6	501 590 10	1	1	1	
7	500 493 00	4	4	4	M 5x10 DIN 7985-4.8 A3R
8	501 591 00	1	1	1	
9	501 607 00	1	1	1	
10	501 588 00	2	2	2	M 4x20 DIN 84-4.8 A3C
11	036 667 00	2	2	2	
12	501 471 00	2	2	2	M 4 DIN 934-8 A3C
13	036 717 01	1	1	1	
14	502 765 01	1	1	1	
15	503 453 00	1	1	1	
16	—	—	—	—	
17	—	—	—	—	
18	—	—	—	—	
19	400 686 00	1	1	1...2	4 M... : 12 V (2) 24 V (1)
20	501 765 00	1	1	1	BATT
21	501 766 00	1	1	1	OIL
22	501 764 00	1	1	1	TEMP
23	501 824 00	1	1	1	FILTER
24	400 960 00	0...2	0...2	0...2	F 17
25	035 092 11	1	1	1	
26	400 097 00	4	4	4	12 V 2W
27	400 098 00	4	4	4	24 V 2W
28	400 914 00	0...2	0...2	0...2	F 24
29	490 509 00	1	1	1	
30	502 766 00	1	1	1	4-P
31	502 767 00	1	1	1	6-P
32	008 182 03	1	1	1	
33	010 898 01	1	1	1	
34	010 899 01	1	1	1	
35	010 902 01	1	1	1	
36	011 501 01	1	1	1	

1 (3-18, 20, 23-26, 28-41, 43, 45, 46)  
2 (3-18, 20, 23-25, 27-40, 42, 44-46)

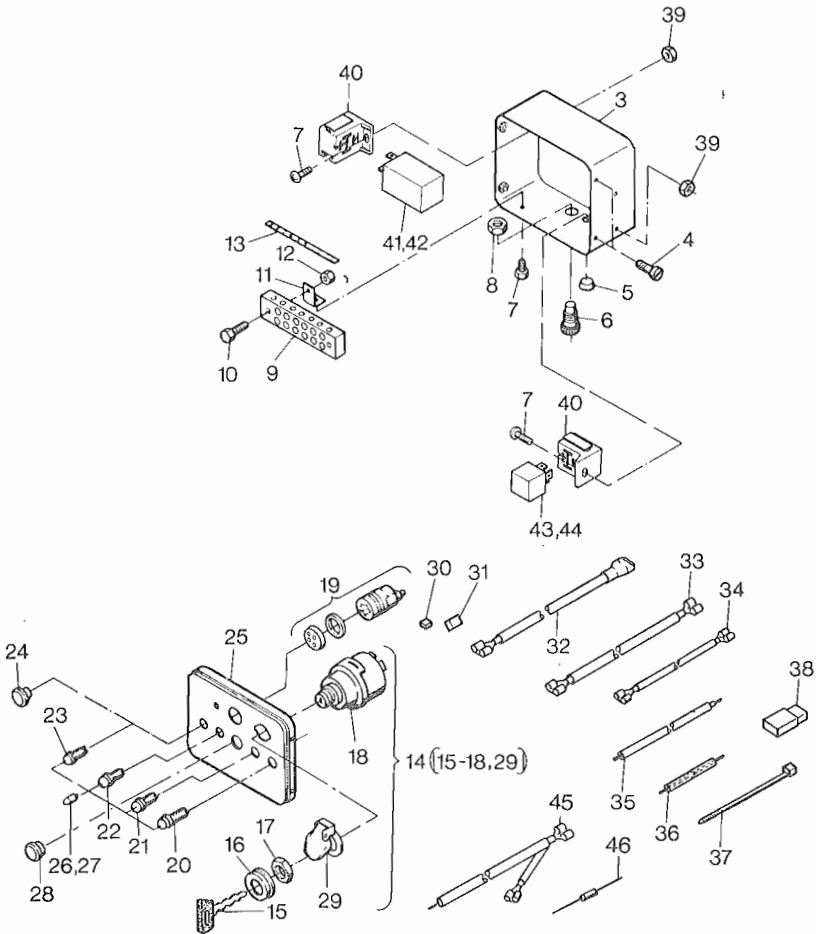

Fig. No.	Bestell-Nr. Ordering No. No. référence No. de pedido	Stück Quantity Quantites Cantidades			Hinweise Hints Indications Indicaciones
		2 M...	3 M...	4 M...	
37	501 674 00	3	3	3	
38	501 907 00	1	1	1	
39	400 282 00	2	2	2	
40	502 760 00	2	2	2	
41	502 758 01	1	1	1	12 V HATZ
42	502 759 01	1	1	1	24 V HATZ
43	502 777 01	1	1	1	12 V Bosch
44	502 778 01	1	1	1	24 V Bosch
45	011 549 01	1	1	1	
46	503 444 00	1	1	1	

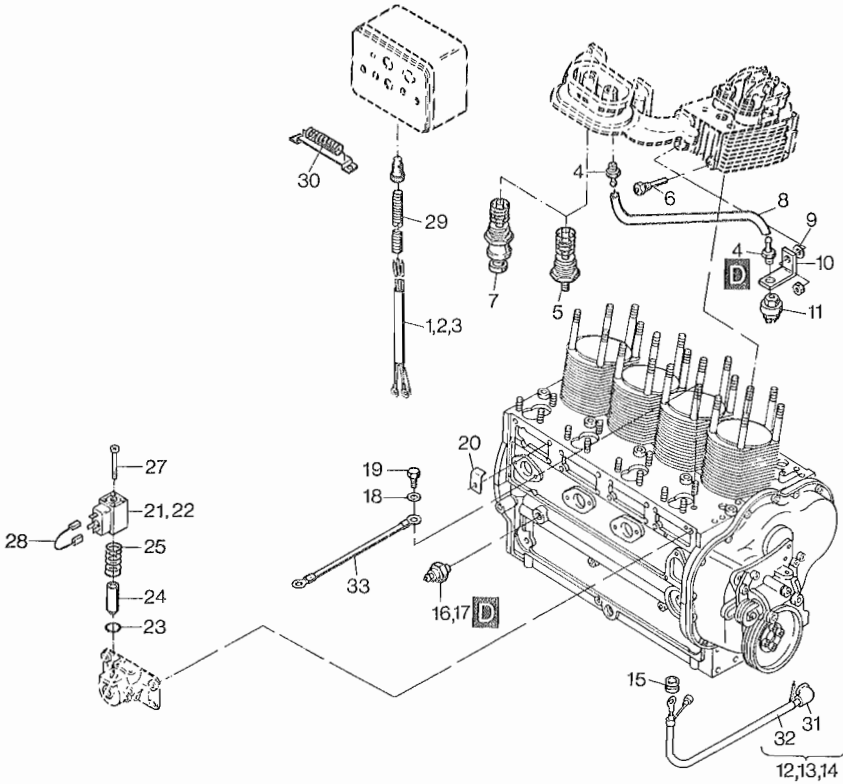

Fig. No.	Bestell-Nr. Ordering No. No. référence No. de pedido	Stück Quantity Quantites Cantidades			Hinweise Hints Indications Indicaciones
		2 M...	3 M...	4 M...	
1	008 218 00	1	—	—	
2	008 219 01	—	1	—	
3	008 175 00	—	—	1	
4	501 677 00	2	2	2	
5	501 639 00	1	1	1...2	184 G 4 M... : 12 V (2) 24 V (1) TEMP
6	502 686 00	1	1	1	
7	501 641 00	—	—	1	400 G 24 V
8	036 937 00	1	1	1	
9	500 167 00	1	1	1	8,4 DIN 125-St
10	036 936 00	1	1	1	
11	501 676 00	1	1	1	
12	008 253 01	1	—	—	
13	008 206 01	—	1	—	
14	008 203 01	—	—	1	
15	501 585 00	1	1	1	
16	400 213 00	1	1	1	OIL
17	—	—	—	—	
18	500 167 00	1	1	1	8,4 DIN 125-St
19	500 267 00	1	1	1	M 8x16 DIN 933-8.8
20	036 666 00	2	2	2	
21	038 668 02	1	1	1	12 V
22	038 669 02	1	1	1	24 V
23	502 750 00	1	1	1	
24	038 976 00	1	1	1	
25	038 977 00	1	1	1	
26	—	—	—	—	
27	502 699 00	2	2	2	M 4x35 DIN 912-8.8 A3C
28	—	—	—	—	
29	036 682 10	1	1	1	2000 mm
30	400 883 00	—	—	1	24 V
31	400 266 00	1	1	1	
32	—	—	—	—	
33	008 171 00	1	1	1	



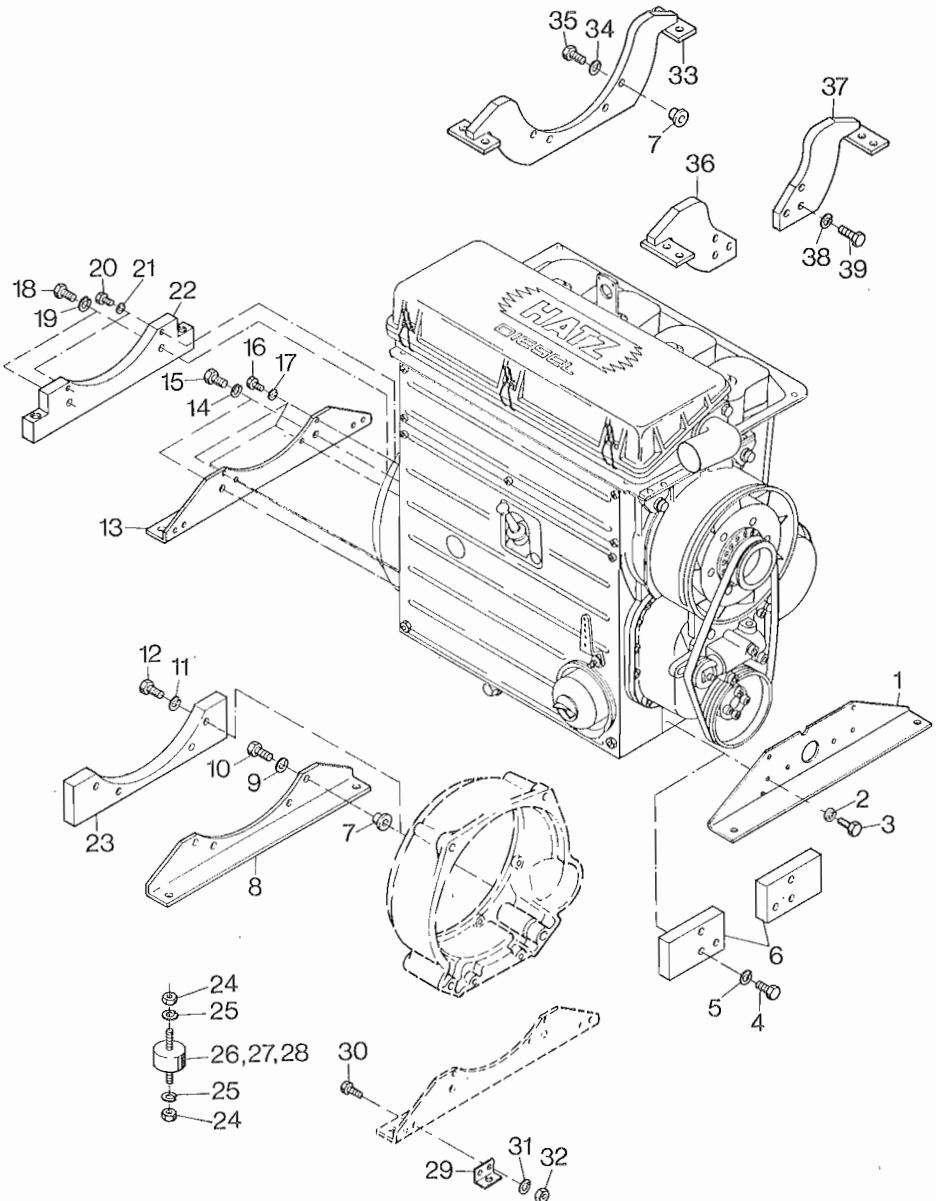

Fig. No.	Bestell-Nr. Ordering-No. No. référence No. de pedido	Stück Quantity Quantités Cantidades	Hinweise Hints Indications Indicaciones	
2...4 M...				
1	038 786 00	1		
2	500 030 00	6	12	DIN 128
3	500 311 00	6	M 12x28	DIN 933-8.8
4	500 316 00	6	M 12x50	DIN 931-8.8
5	500 632 00	6	12	DIN 128 A3C
6	038 536 01	2		
7	035 791 00	4		
8	038 787 00	1		
9	500 030 00	4	12	DIN 128
10	502 593 00	4	M 12x110	DIN 931-8.8 A3C
11	500 632 00	4	12	DIN 128 A3C
12	502 593 00	4	M 12x110	DIN 931-8.8 A3C
13	038 788 00	1		
14	500 031 00	2	14	DIN 128
15	501 875 00	2	M 14x1,5x30	DIN 961-8.8
16	500 029 00	4	10	DIN 128
17	500 292 00	4	M 10x25	DIN 933-8.8
18	502 756 00	2	M 14x1,5x55	DIN 960-8.8
19	502 599 00	2	14	DIN 128 A3C
20	500 296 00	2	M 10x45	DIN 933-8.8 A3C
21	501 356 00	2		
22	038 550 01	1	10	DIN 128 A3C
23	038 549 01	1		
24	501 458 00	8	M 10	DIN 934-8 A3C
25	501 356 00	8	10	DIN 128 A3C
26	502 601 00	4	40 SH	7
27	502 602 00	4	55 SH	8
28	502 603 00	4	65 SH	9
29	038 754 00	2		
30	500 293 00	4	M 10x30	DIN 933-8.8
31	500 029 00	4	10	DIN 128
32	500 235 00	4	M 10	DIN 934-8
33	010 896 00	1		
34	500 632 00	4	12	DIN 128
35	502 593 00	4	12x110	DIN 931-8.8 A3C
36	010 894 00	1		
37	010 895 00	1		
38	500 632 00	6	12	DIN 128
39	502 322 00	6	M 12x40	DIN 933-8.8 A3C

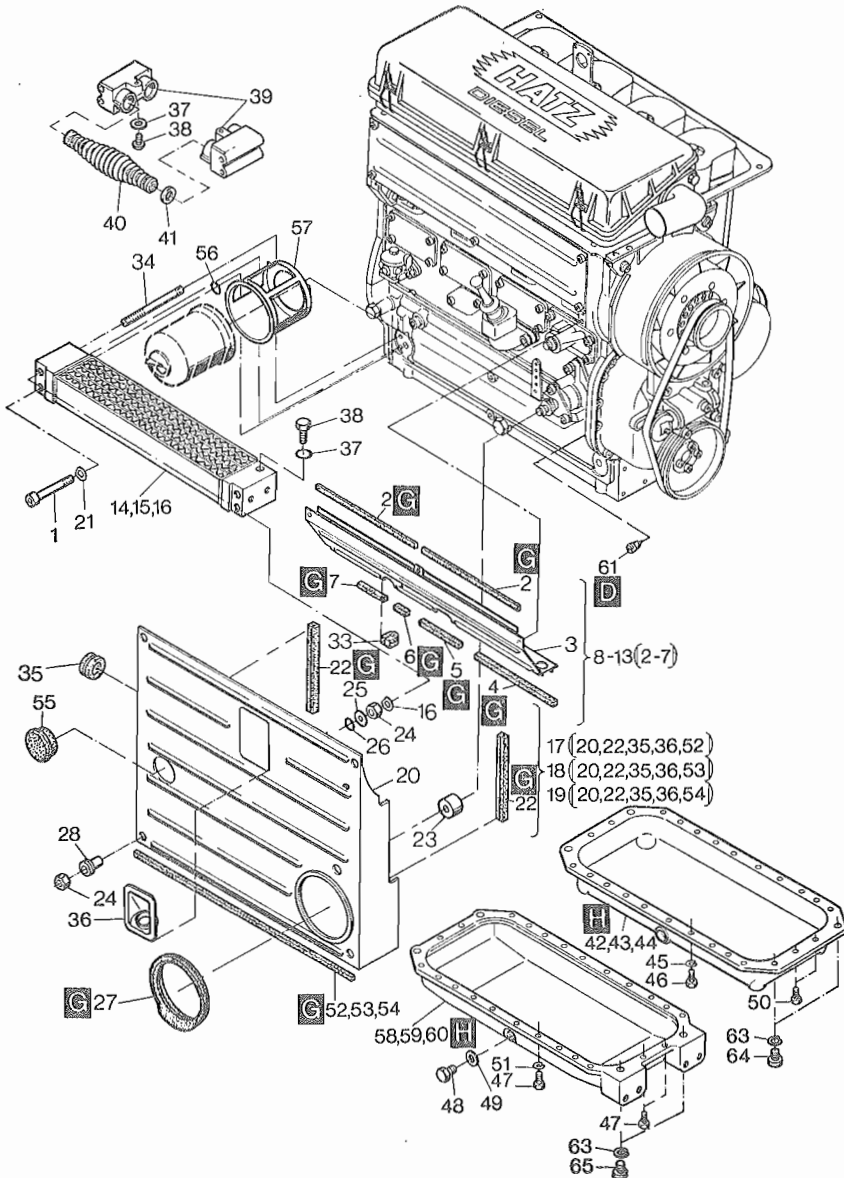

Fig. No.	Bestell-Nr. Ordering-No. No. référence No. de pedido	Stück Quantity Quantites Cantidades			Hinweise Hints Indications Indicaciones	
		2 M...	3 M...	4 M...		
1	502 041 00	2	2	2	M 8x95	DIN 6912-8.8
2	035 640 00	1	—	—	231 mm	
2	035 636 00	—	2	—	173 mm	
2	035 726 00	—	—	2	240 mm	
3	—	—	—	—		
4	035 637 01	—	1	1	214 mm	
5	035 725 01	—	—	1	97 mm	
6	035 644 01	1	—	—	128 mm	
6	035 985 00	—	1	—	32 mm	
6	035 990 00	—	—	1	30 mm	
7	035 987 00	1	—	—	47 mm	
7	035 638 00	—	1	—	67 mm	
8	007 475 11	1	—	—		
9	007 476 11	—	1	—		
10	007 477 11	—	—	1		
11	010 806 00	1	—	—	} f. Taf./Tab.28, Pos.21,22	
12	010 808 00	—	1	—		
13	010 810 00	—	—	1		
14	036 478 01	1	—	—	2601 ... 3000 min <sup>-1</sup>	
15	036 479 01	—	1	—		
16	036 480 01	—	—	1		
17	007 435 10	1	—	—		
18	007 437 10	—	1	—		
19	007 460 10	—	—	1		
20	—	—	—	—		
21	500 035 00	4	4	4	B 8	DIN 137
22	035 662 00	2	2	2	168 mm	
23	035 794 00	1	1	1		
24	500 229 00	4	4	4	M 8	DIN 934-8
25	035 956 00	2	2	2		
26	035 755 00	2	2	2		
27	035 940 01	1	1	1		
28	009 214 00	2	2	2		
29	—	—	—	—		
30	—	—	—	—		
31	—	—	—	—		

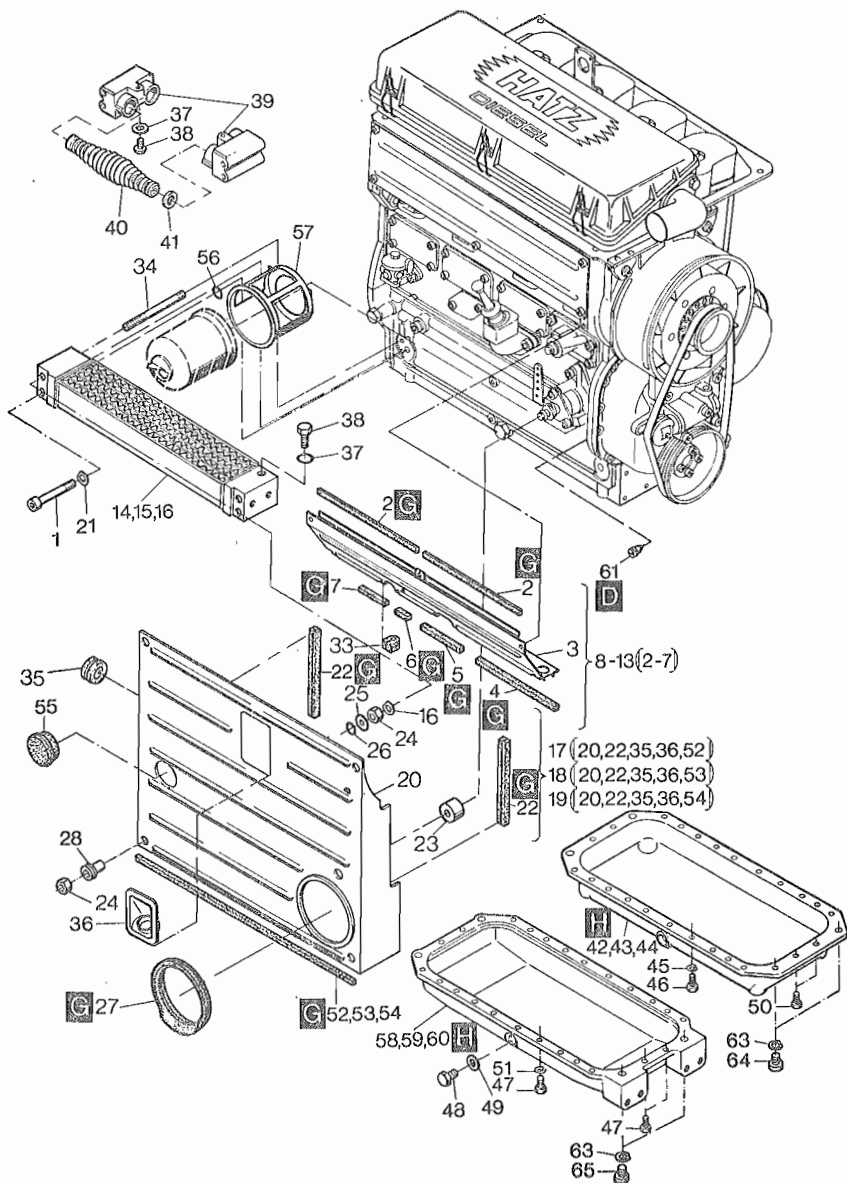

Fig. No.	Bestell-Nr. Ordering-No. No. référence No. de pedido	Stück Quantity Quantites Cantidades			Hinweise Hints Indications Indicaciones
		2 M...	3 M...	4 M...	
32	—	—	—	—	
33	035 689 00	1	1	1	
34	035 814 01	2	2	2	
35	501 587 00	1	1	1	
36	037 614 00	1	1	1	
37	500 009 00	1	—	—	A 8x11,5    DIN 7603-Cu
38	501 379 00	1	—	—	M 8x1        DIN 7604
39	035 553 02	2	—	—	} 1801 ... 2600 min <sup>-1</sup> Gen.: 1500+1800 min <sup>-1</sup>
40	035 552 02	2	—	—	
41	400 798 00	4	—	—	
42	009 175 00	1	—	—	
43	009 176 00	—	1	—	
44	009 177 01	—	—	1	
45	500 028 00	8	14	24	8            DIN 128
46	500 267 00	8	14	24	M 8x16     DIN 933-8.8
47	500 270 00	12	18	24	8x25        DIN 933-8.8
48	501 404 00 W1	1	1	1	AM 22x1,5    DIN 7604-5.8
49	500 016 00 W4	1	1	1	A 22x27     DIN 7603-Cu
50	502 793 00	4	4	—	M 8x16     DIN 933-8.8
51	500 028 00	8	14	24	8            DIN 128
52	037 771 00	1	—	—	203 mm
53	037 772 00	—	1	—	338 mm
54	037 773 00	—	—	1	473 mm
55	037 693 01	1	1	1	
56	501 304 00	2	2	2	
57	009 243 00	1	1	1	
58	036 005 00	1	—	—	
59	036 006 00	—	1	—	
60	036 007 01	—	—	1	
61	034 657 00	1	1	1	
62	—	—	—	—	
63	500 030 00	4	4	4	12            DIN 128
64	500 806 00	4	4	4	M 12x20     DIN 912-8.8
65	500 570 00	4	4	4	M 12x75     DIN 912-12.9

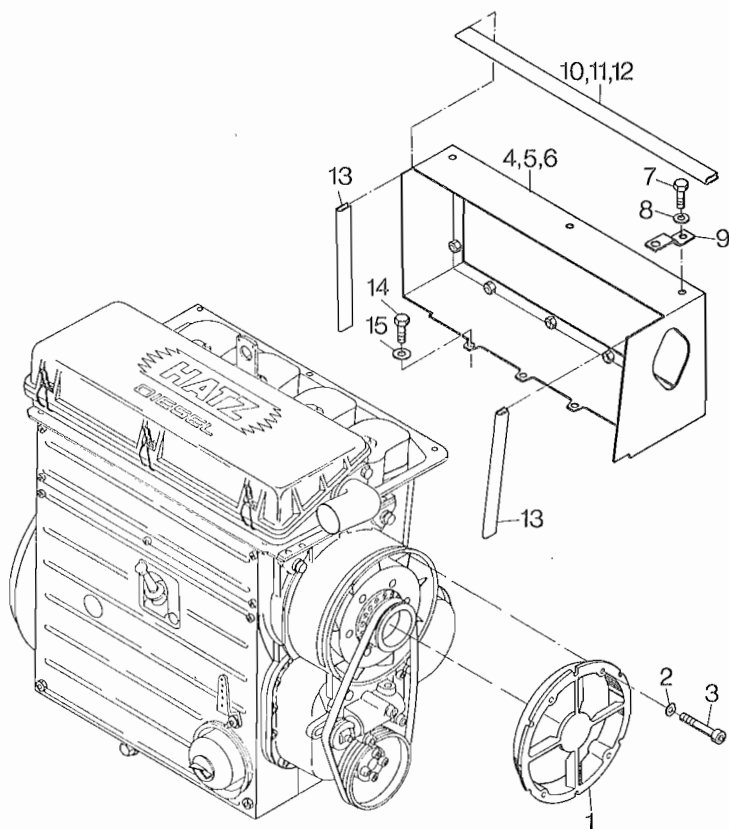

Fig. No.	Bestell-Nr. Ordering-No. No. référence No. de pedido	Stück Quantity Quantites Cantidades			Hinweise Hints Indications Indicaciones	
		2 M...	3 M...	4 M...		
1	038 052 00	1	1	1		
2	500 812 00	4	4	4	A 6	DIN 137 A3C
3	501 984 00	4	4	4	M 10x55	DIN 912-8.8
4	010 118 00	1	—	—		
5	010 311 00	—	1	—		
6	010 312 00	—	—	1		
7	501 655 00	2	3	3	M 6x12	DIN 933-8.8 A3C
8	501 445 00	2	3	3	6,4	DIN 125-St A3C
9	038 991 00	2	3	3		
10	037 471 00	1	—	—		
11	037 472 00	—	1	—		
12	037 473 00	—	—	1		
13	037 475 00	2	2	2		
14	500 962 00	4	6	7	M 8x12	DIN 933-8.8 A3C
15	501 481 00	4	6	7	8,4	DIN 125-St A3C



A 12

Keilriemenschutz  
V-belt guard  
Protecteur courrie  
Proteccion corea

A 15

Anschlußgehäuse  
Intermediate housing  
Bride raccord  
Caja de conexión

Tafel Nr.  
Tabl. No.

32

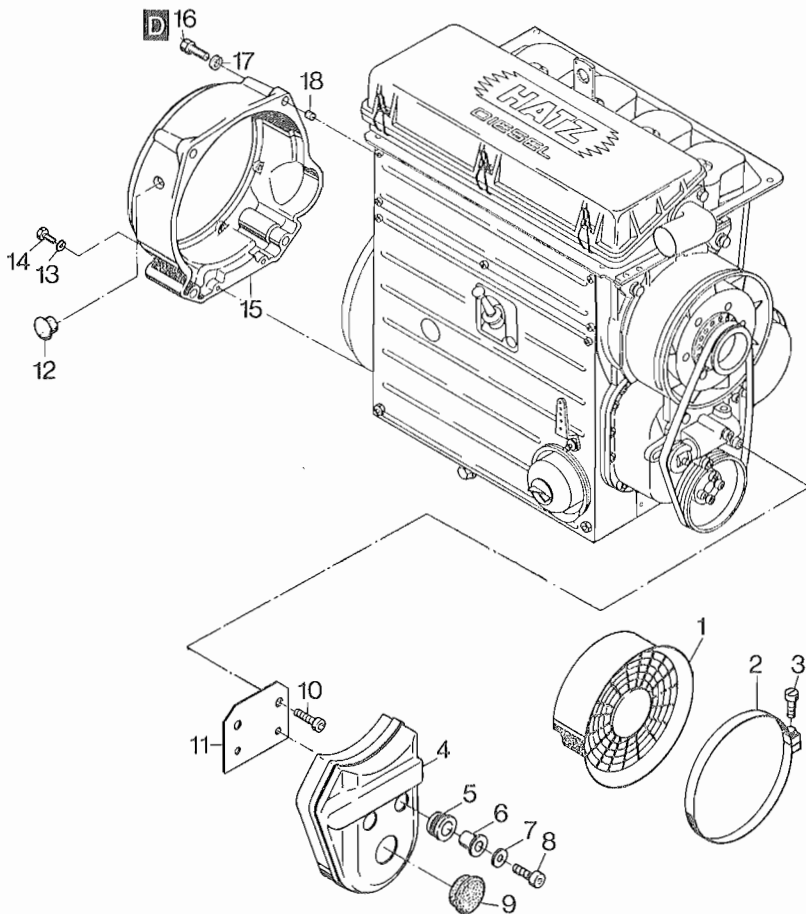

Fig. No.	Bestell-Nr. Ordering No. No. référence No. de pedido	Stück Quantity Quantites Cantidades	Hinweise Hints Indications Indicaciones	
2... 4 M...				
1	036 839 00	1		
2	038 024 00	1		
3	502 843 00	1	M 4x30	DIN 84-4.8 A3C
4	037 110 00	1		
5	036 652 00	2		
6	033 776 00	2		
7	501 143 00	2	6,4	DIN 7349 Zn
8	501 706 00	2	M 6x20	DIN 912-8.8 A3C
9	501 518 00	1	F 31	
10	500 530 00	2	M 8x70	DIN 912-8.8
11	036 840 01	1		
12	502 376 00	1	F 19	
13	500 029 00	2	10	DIN 128
14	500 296 00	2	M 10x45	DIN 933-8.8
15	035 759 02	1	SAE 5	
16	501 373 00	4	M 14x1,5x50	DIN 960-8.8
17	500 031 00	4	14	DIN 128
18	501 374 00	4	18x18	DIN 7346

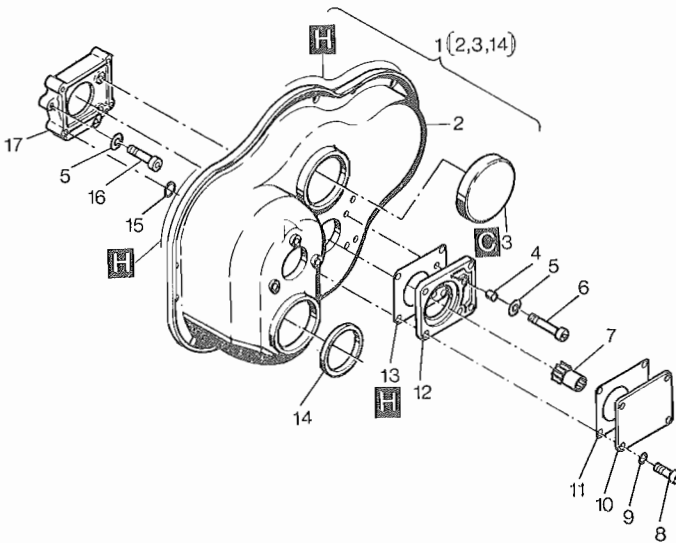

Fig. No.	Bestell-Nr. Ordering-No. No. référence No. de pedido	Stück Quantity Quantites Cantidades	Hinweise Hints Indications Indicaciones	
		2... 4 M...		
1	009 935 00	1		
2	—	—		
3	501 265 00	1		
4	502 620 00	2	10x10	DIN 7346
5	501 282 00	4	8	DIN 127
6	502 581 00	2	M 8x60	DIN 6912-8.8
7	010 623 00	1		
8	502 688 00	4	M 8x30	DIN 912-8.8
9	501 629 00	4	A 8x14	DIN 7603-Cu
10	037 616 00	1		
11	035 680 00	1		
12	035 550 11	1		
13	037 544 00	1		
14	501 291 00	1		
15	400 223 00	2	8x12x2	
16	500 525 00	2	M 8x40	DIN 912-8.8
17	037 543 00	1		

**Änderungsübersicht**  
**Modification table**  
**Aperçu de modifications**  
**Table de modificaciones**

Bildtafel Table Planche Tabla	Pos. Nr. Fig. No. Fig. No. Fig. No.	Bestell-Nr. Ordering No. No. référence No. de pedido	Stück Qty. Qté. Cant.	Bildtafel Table Planche Tabla	Pos. Nr. Fig. No. Fig. No. Fig. No.	Bestell-Nr. Ordering No. No. référence No. de pedido	Stück Qty. Qté. Cant.	IMT NO.
2 M 40.13				2 M 40.14				86.456
3 M 40.13				3 M 40.14				86.456
4 M 40.13				4 M 40.14				86.456
2 M 31.10				2 M 31.11				87.468
3 M 31.10				3 M 31.11				87.468
4 M 31.10				4 M 31.11				87.468
2 M 40.14				2 M 40.15				87.468
3 M 40.14				3 M 40.15				87.468
4 M 40.14				4 M 40.15				87.468