

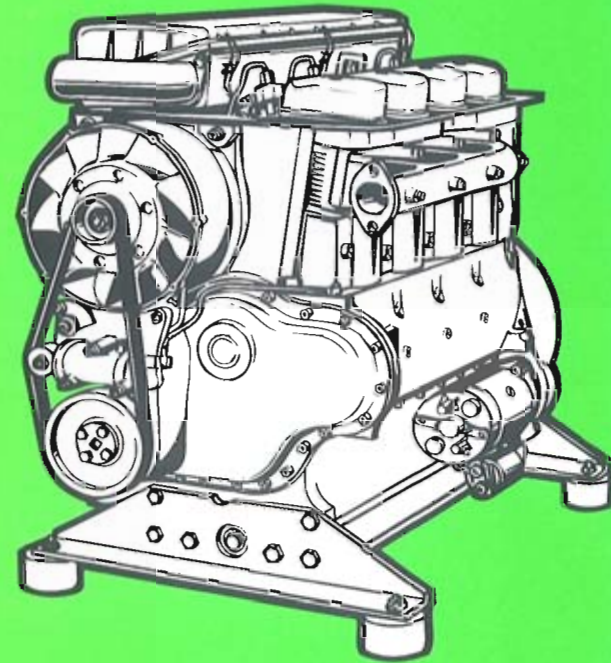

MOTORENFABRIK HATZ • D-94099 Ruhstorf • Germany  
Tel.: 0 85 31 / 319-0 • Telex: 57260 • Telefax: 0 85 31 / 31 94 18  
eMail: hatz.marketing@t-online.de • http://www.hatz.com

**Original-Ersatzteile**  
Original-spare parts  
Pièces de rechange d'origine  
Repuestos originales  
Pezzi di ricambio originali



- 2 M 31 .
- 3 M 31 .
- 4 M 31 .
- 2 M 40 .
- 3 M 40 .
- 4 M 40 .
- 2 M 41 .
- 3 M 41 .
- 4 M 41 .

434 600 01 - 12.97 - 5  
Printed in Germany  
DM 3.50

# Bestellung für HATZ-Original-Ersatzteile

Order for HATZ Original spare parts

Commande de pièces d'origine HATZ

Pedido de repuestos originales HATZ

Ordine parti di ricambio originali HATZ

1

Besteller / Customer / Client / Cliente / Cliente

2

TYP  
MOTOR/FABRIK NO.  
MIN-1



3

Ersatzteilliste Nr./ Spare parts list no./ Liste des pièces de rechange no./ Lista de repuestos No./ Lista ricambi n.

2 M 31 . 14	<input type="checkbox"/>	3 M 31 . 14	<input type="checkbox"/>	4 M 31 . 14	<input type="checkbox"/>
2 M 40 . 18	<input type="checkbox"/>	3 M 40 . 18	<input type="checkbox"/>	4 M 40 . 18	<input type="checkbox"/>
2 M 41 . 10	<input type="checkbox"/>	3 M 41 . 10	<input type="checkbox"/>	4 M 41 . 10	<input type="checkbox"/>

4

Stück / Qty / Q.tà	HATZ Ident No.	Stück / Qty / Q.tà	HATZ Ident No.

5

Versandart / Mode of dispatch / Mode d'expédition / Despacho deseado / Modo di spedizione

Post / Surface / Poste / Correo / Posta  Luftfracht / airfreight / frêt aérien / flete aereo / Via aerea

Express / express / exprès / expreso / Espresso  .....

6

Versandadresse / Consignee / Adresse destination / Dirección / Indirizzo di destinazione

- Bestellung an: Order at: Commande à: Pedido a:
- die nächste HATZ-Servicestelle (siehe Servicestellenverzeichnis)
  - your nearest HATZ service station (see service-list)
  - votre station-service HATZ la plus proche (voir liste "Service")
  - al servizio HATZ más cercano (ver cuaderno de Servicio)
  - al più vicino centro di servizio HATZ (vedi lista centri autorizzati)

**MOTORENFABRIK HATZ**  
**D-94099 RUHSTORF**  
Tel: 0 85 31 / 319 - 0  
Fax: 0 85 31 / 31 94 21



<b>Inhaltsverzeichnis</b>		<b>Index</b>	
<b>M ..</b>	<b>Grundmotor</b>	<b>Basic engine</b>	
00	Ersatzteilsätze	Spare parts kits	01
34	Zubehör	Accessories	02
01	Kurbelgehäuse	Crankcase	03 + 04
01	Massenausgleich	Compensation of masses	05
02, 03	Kurbelwelle	Crankshaft	06
04	Nockenw., Regler, Spritzversteller	Camshaft, governor, timer	07
04	Drehzahlverstellung	Speed control	08
05, 06	Kolben, Pleuel, Zylinder	Piston, conrod, cylinder	09
07	Zylinderkopf	Cylinder head	10
08	Deckel z. Zyl.-Kopf	Cover cyl.-head	11
09, 10	Stoßstangen, Ölpumpe	Pushrod, oil pump	11
11	Steuerdeckel	Timing cover	12
12	Startfüllung	Extra fuel device	13
13	Gebläse	Blower	14
14	Einspritzausrüstung	Injection equipment	15
16, 17	Riemenscheibe, Schwungrad	Pulley, flywheel,	
20	Hydr. Abstellvorrichtung	hydr. belt tensioner	16
22, 27	Luftfilter, Luftansaugrohr	Air filter, air intake manifold	17
26	Luftführung	Air ducting	18, 19
			20
<b>A ..</b>	<b>Zusatzausrüstung</b>	<b>Equipements</b>	
01	Förderpumpe	Fuel feed pump	21
01	Kraftstoffbehälter	Fuel tank	22
02	Zyklon	Cyclon	23
03	Auspuff	Exhaust	24
04	Andrehkurbel, Andrehvorr.	Starting handle, starting device	25
04	Dekompressionsautomatik	Autom. decompression	26
04	Abschaltautomatik mech.	Autom. shut-off device mec.	27
05	Starter, Generator	Starter, alternator	28
05, 10	Armaturenkasten	Instrument box	29
05, 10	Armaturen, Leitungen	Electric equipment, wirings	30
06	Motorfüße, Schwingungsdämpfer	Engine brackets, vibration damper	31
07	Ölkühler, Ölwanne	Oil cooler, oil sump	32
08	Anbaut. Zuluftschacht, Abluftschacht	Air duct. adaption, air ducting	33
12, 15	Keilriemenschutz, Anschlußgeh.	V-belt guard, intermediate housing	34
16	Elastische Kupplung	Flexible coupling	35
18	Steuerdeckel f. Hydraulik	Timing cover hydr.	35
			Seite/Page
	Serien-Nr.-Änderungen	Serial-code modification list	98

<b>Sommaire</b>		<b>Indice</b>		Tableau Tabla N
<b>M ..</b>	<b>Moteur de base</b>	<b>Motor de base</b>		
00	Jeu de pièces de rechange	Juegos de pieza de recambios,		01
34	Accessoires,	Accesorios,		02
01	Carter moteur	Caja cigueñal		03 + 04
01	Equilibrage des masses	Compensación de las masas		05
02, 03	Vilebrequin	Cigueñal		06
04	Arbre à cames, regulateur regime, variateur d'avance	Arbol de levas, regulador variador de avance		07
04	Reglage regime	Ajuste de revoluciones		08
05, 06	Piston, bielle, cylindre	Embolo, biela, cilindro		09
07	Culasse	Culata		10
08	Couvercle culasse	Tapa culata		11
09, 10	Tige de culbuteur, pompe a huile	Varilla de balancín, bomba de aceite		11
11	Couvercle distribution	Tapa de mando		12
12	Surcharge	Sobre aliment.-arranque		13
13	Soufflerie	Ventilador		14
14	Equipement d'injection	Equipo de inyección		15
16, 17	Poulie, volant,	Polea, volante,		
20	tendeur hydr.	tensor hidráulico		16
22, 27	Filtre à air, collecteur d'admission	Filtro de aire, tubo de aspiración		17
26	Carter ventilation	Conducción de aire		18, 19 20
<b>A ..</b>	<b>Accessoires</b>	<b>Equipos</b>		
01	Pompe alimentation	Bomba de alimentacion		21
01	Reservoir à carburant	Depósito combustible		22
02	Cyclone	Ciclon		23
03	Echappement	Escape		24
04	Manivelle, dispositif demarrage	Manivela, dispositivo de arranque		25
04	Décompression autom.	Decompresión autom.		26
04	Arret moteur autom. mec.	Parada del motor autom. mec.		27
05	Demarreur, alternateur	Arrancador, alternador		28
05, 10	Boitiere de bord	Cuadro de mando		29
05, 10	Equipement électrique, cable	Equipo eléctrico, cables		30
06	Pieds moteur, amort. vibrat.	Soportes del motor, amort. vibrac.		31
07	Radiateur d'huile, carter d'huile	Radiador de aceite, carter de aceite		32
08	Bati connexion, carter ventilation	Bastidor de conex., chapa de aire		33
12, 15	Protecteur courroie, bride raccord	Proteccion corea, caja de conexión		34
16	Accouplement elastic	Acoplamiento elast.		35
18	Couvercle pompe hydraulic	Tapa de mando p. hidraulico		35
	Modification des Nos de serien	Modificación de los Nos de serie		Page/PáginaNc 98

<b>Indice</b>	Tavola N.
<b>M .. Motore di base</b>	
00	Serie guarnizioni 01
34	kit accessori 02
01	Basamento motore 03 + 04
01	Masse controrotanti 05
02, 03	Albero a gomito, 06
04	Albero a camme, regolatore di giri variante di anticipo 07
04	Comando acceleratore 08
05, 06	Pistone, biella, cilindro 09
07	Testa 10
08	Coperchio bilancieri 11
09, 10	Asta bilancieri, pompa olio 11
11	Coperchio distribuzione 12
12	Supplemento 13
13	Ventilatore 14
14	Equipaggiamento di iniezione 15
16,17	Puleggia, volano
20	tendicinghia idraulico 16
22, 27	Filtro aria, collettore aspirazione 17
26	Carter ventilatore 18, 19
	20
<b>A .. Accessori</b>	
01	Pompa A. C. 21
01	Serbatoio 22
02	Prefiltro a ciclone 23
03	Scarico 24
04	Manovella, dispositivo de avviam. 25
04	Decompressione automatica 26
04	Arresto automatico motore 27
05	Motorino avviamento, alternatore 28
05, 10	Cruscotto 29
05, 10	Equipaggiam. elettrico, cablaggio 30
06	Staffe supporto motore, antivibranti 31
07	Radiatore olio, coppa olio 32
08	Convogliatore uscita aria calda 33
12, 15	Protezione cinghia, campane accoppiamento 34
16	Giunto elastico 35
18	Coperchio per pompa idraulica 35
	Pagina
Modifica dei codici	98

M 00 Ersatzteilsätze  
Spare part kits  
Jeux de pièces de rechange  
Juegos de piezas de recambios  
Serie guarnizioni

Tafel Nr.  
Tabl. No.  
Tavola N.

01

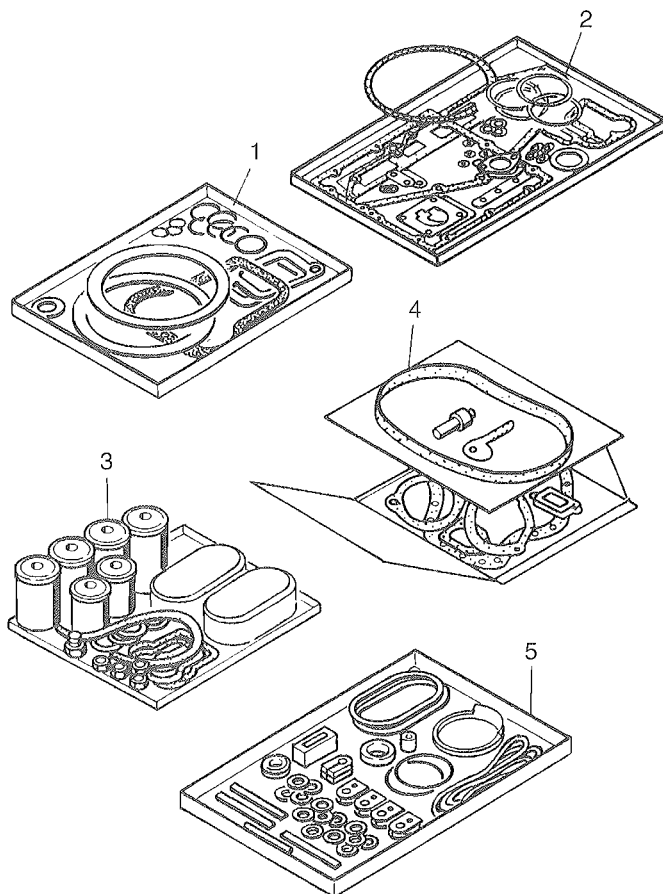

Fig.- No.	HATZ Ident-No.	Stück Qty.		P / W d / D	Bemerkungen Notes
		2 M . .	3 M . .	4 M . .	
					<p>W: Im Wartungssatz enthalten. Incl. in maintenance kit. Contenu dans le jeu d'entretien. Incluido en el juego de mantenimiento. Contenuto nella serie manutenzione</p> <p>d: Im Dichtungssatz für 1 Zyl.-Kopf enthalten. Incl. in gasket set for 1 cylinder head. Contenu dans le jeu de joint p. 1 culasse. Incluido en el juego de juntas p. 1 culata. Contenuto nella serie guarnizioni p. 1 testa.</p> <p>P: Im Pannensatz enthalten. Incl. in emergency kit. Contenu dans le jeu secur. Incluido en el juego para averias. Contenuto nella serie di prima necessità.</p> <p>D: Im Dichtungssatz Kurbelgehäuse Incl. in gasket set crankcase. Contenu dans le jeu de joints carter moteur. Incluido en el juego de juntas caja cigueñal. Contenuto nella serie guarnizioni basamento.</p> <p>1: Anzahl pro Satz - Qty. per kit Quantite par jeu Cantidad por juego. Quantità per serie.</p>
1	00992202	2	3	4	P1 Dichtungssatz für 1 Zylinderkopf Gasket set for 1 cyl. head Jeu de joint p. 1 culasse Juego de juntas para 1 culata. Serie guarnizioni per 1 testa.
2	01230902	1	1	1	Dichtungssatz für Kurbelgehäuse Gasket set for crankcase Jeu de joints p. carter moteur Juego de juntas para caja cigueñal. Serie guarnizioni basamento.
3	00987104	1	-	-	Wartungssatz für 1000 h
3	00991504	-	1	-	1000 hours maintenance kit
3	01203304	-	-	1	Kit d'entretien 1000 heures - Juego de piezas para servicio 1000 horas. Kit di manutenzione a 1000 ore.
4	01226201	1	1	1	Pannensatz - Emergency kit
4	01544200	1	1	1	2-4M41 Kit de secours - Juego para averias. Kit di prima necessità.
5	01215601	1	1	1	Gummitellesatz, Rubber comp. set Garniture caout., Guarnicion goma Guarnizioni in gomma.





Fig.- No.	HATZ Ident-No.	Stück Qty.	P / W d / D	Bemerkungen Notes	
		2 M . .	3 M . .	4 M . .	
1	00938301	1	1	1	Zubehörsatz - Accessoires kit Sort. accessoires Juego de accesorios Serie accessori
2	03788101	1	1	1	
3	03430612	1	1	1	
4	03325400	1	1	1	

Dicht- und Klebstoffe Sealing- and bonding adhesives			Etanchéifiant et Colle Materias para empaquetar y pegar	
A = 502 230 01	Loctite Activator N	500 ml	}	siehe Hinweis auf den einzelnen Bildtafeln as specified in the individual tables suivant les remarques sur les tableau correspondant según las indicaciones de las tablas correspondientes seguire le indicazioni sul quadro corrispondente
B = 502 231 00	Loctite 573	50 ml		
C = 502 232 00	Loctite 601	50 ml		
D = 502 233 00	Loctite 221	50 ml		
E = 502 234 00	Loctite 648	10 ml		
F = 502 238 00	Technicoll 8058	0,75 kg		
+ 502 239 00	Technicoll 8367	0,75 kg		
G = 502 565 01	Loctite IS 407	20 g		
H = 502 825 01	Silicon	30 ml D1		
J = 502 830 02	Hochtemp. Paste	1000 g		



Fig.- No.	HATZ Ident-No.	Stück Qty.			P / W d / D	Bemerkungen Notes
		2 M . .	3 M . .	4 M . .		
1	00975702	1	-	-		
2	00991802	-	1	-		
3	01200901	-	-	1		
4	50140000	4	4	4		8 x 8     DIN 7346
5	50130500	2	2	2		5 x 24     DIN 1481
6	03469300	6	8	10		
7	50125900	6	8	10		M 12 x 1,5 x 190 DIN 912-10.9
8	50290800	5	8	11		M 8 x 20    DIN 939-10.9
9	50130500	1	1	1		5 x 24     DIN 1481
10	03635300	1	1	1		
11	-----	-	-	-		
12	50131400	2	2	2		10 m 6 x 14 DIN 7-St 50K
13	50084901	2	2	2		8 x 12     DIN 7346
14	50130200	1	1	1		HK 16/16
15	03863600	1	1	1		
16	03627100	-	-	4		48
17	50140400	2	2	2	W1	AM 22 x 1,5 DIN 7604-5.8
18	50001600	2	2	2	W4,D4	A 22 x 27    DIN 7603-Cu
19	03645700	2	2	2		n ≤ 1500 min <sup>-1</sup>
20	40065400	1	1	1		
21	50062400	1	1	1	D3	A 10 x 13,5 DIN 7603-Cu
22	50062300	1	1	1		M 10 x 1    DIN 908
23	50026800	8	12	17		8 x 20     DIN 933-8.8
24	50002800	8	12	17		8            DIN 128
25	03249300	1	1	1		
26	50001400	1	1	1	W4,D2	A 18 x 22    DIN 7603-Cu
27	03639900	1	1	1		
28	03639800	1	1	1		
29	50139200	2	2	2		M 6 x 16    DIN 939-8.8
30	-----	-	-	-		
31	50043800	1	1	1		M 14 x 1,5    DIN 906
32	50026500	2	2	-		M 8 x 10    DIN 933-8.8
33	50162900	2	2	-	D6	A 8 x 14     DIN 7603-Cu
34	50279300	4	4	-		M 8 x 16    DIN 933-8.8
35	50140800	2	2	-		38            DIN 443

**M 01**

Kurbelgehäuse  
Crankcase  
Carter moteur  
Caja cigueñal  
Basamento motore

Tafel Nr.  
Tabl. No.  
Tavola N.

**03**

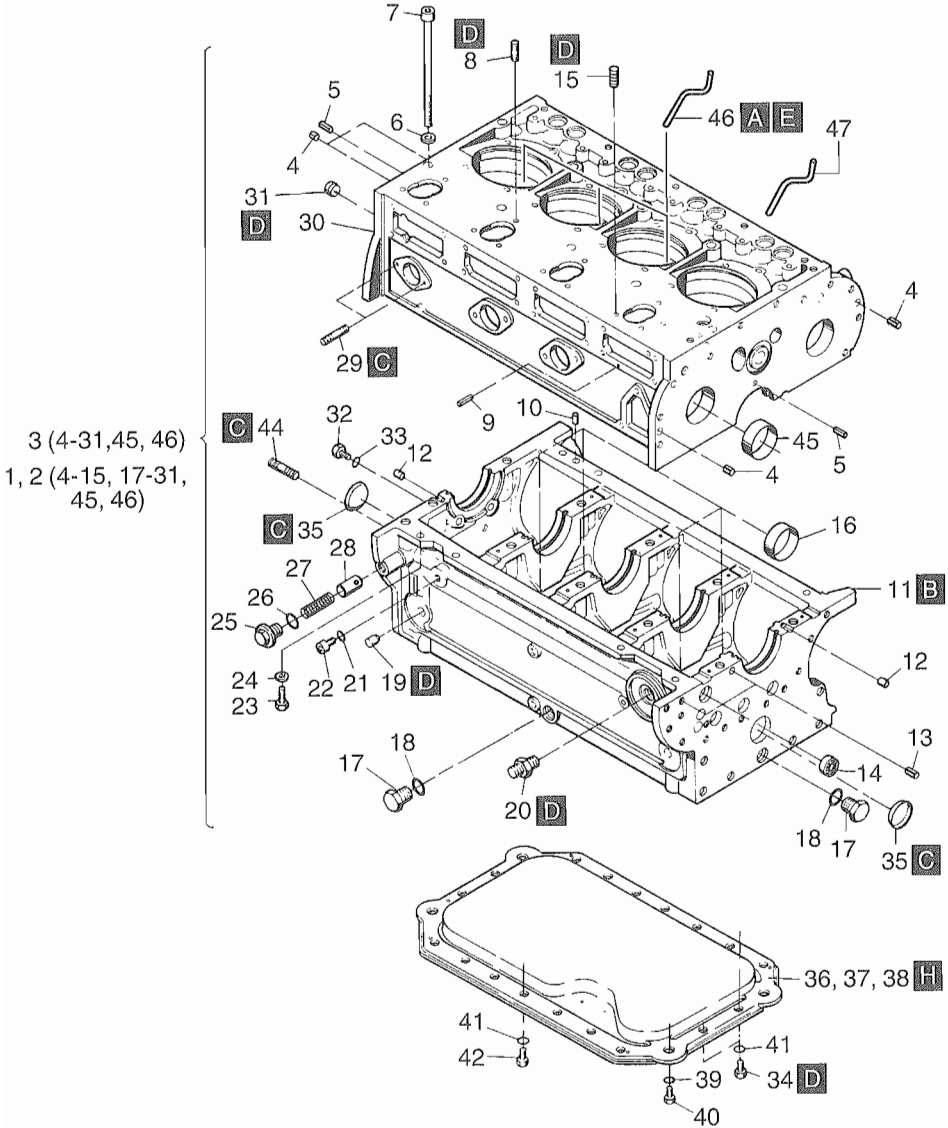

Fig.- No.	HATZ Ident-No.	Stück Qty.			P / W d / D	Bemerkungen Notes
		2 M . .	3 M . .	4 M . .		
36	03752601	1	-	-		
37	03752701	-	1	-		
38	-----	-	-	-		s.Taf.,Tabl.32, Pos.44
39	50003000	4	4	-	12	DIN 128
40	50080600	4	4	-	M 12 x 20	DIN 912-8.8
41	50002800	12	18	-	8	DIN 128
42	50026700	8	14	-	M 8 x 16	DIN 933-8.8
45	03765500	1	1	1		
46	03645900	1	2	3		} s.Techn. Hinweis 950 386 01 } s.drawing 950 386 01
47	03646000	1	1	1	.M41	

M 01

Kurbelgehäuse  
Crankcase  
Carter moteur  
Caja cigueñal  
Basamento motore

Tafel Nr.  
Tabl. No.  
Tavola N.

04

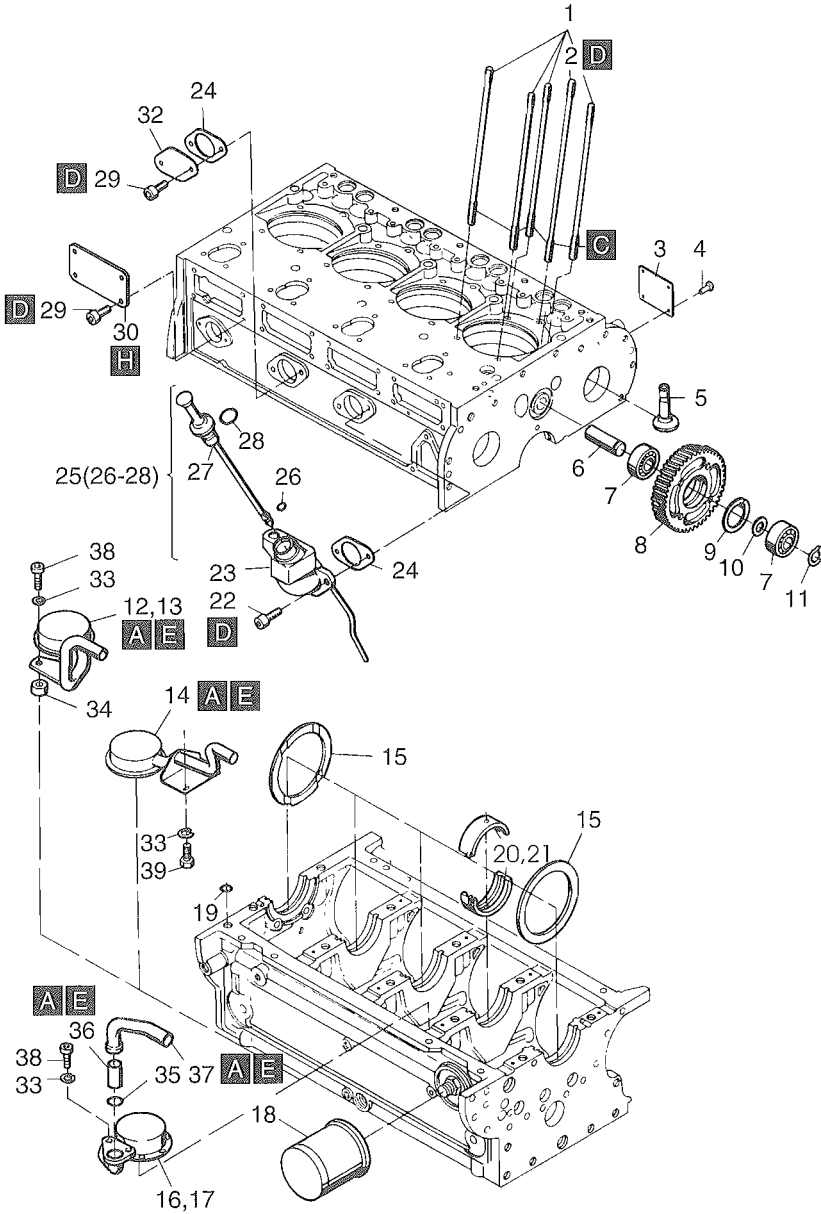

Fig.- No.	HATZ Ident-No.	Stück Qty.	P / W d / D	Bemerkungen Notes	
		2 M . .	3 M . .	4 M . .	
1	03625702	8	12	16	
2	03625802	2	3	4	
3	03225504	1	1	1	
4	40002500	4	4	4	
5	03554501	4	6	8	
6	03469601	1	1	1	
7	50013700	2	2	2	6204 C3 DIN 625
8	03561702	1	1	1	
9	50021700	1	1	1	47 x 1,75 DIN 472
10	03462300	1	1	1	
11	50127600	1	1	1	20 x 1,75 DIN 471
12	00929301	1	-	-	
13	00929401	-	1	-	
14	00929201	-	-	1	f.Taf./Tabl.32, Pos.44,60
15	03463300	2	2	2	
16	00929001	1	-	-	} f.Taf./Tabl. 32, Pos.42,43, 58,59
17	00929101	-	1	-	
18	40065300	1	1	1	W2
19	50219400	1	1	1	D1 12 x 2
20	03555500	3	4	5	Ø 72 mm
21	03551600	3	4	5	Ø 71,5 mm
22	50051900	2	2	2	M 8 x 20 DIN 912-8.8
23	00932602	1	-	-	
23	00914803	-	1	1	
24	50129000	1	1	2	D2 36
25	00739702	1	1	-	„A“
25	00931100	1	-	-	„C“ f.Taf./Tabl.32, Pos. 42,43,44, 58,59,60
25	00930800	-	1	1	„D“
26	50202502	1	1	1	D1 3,0 x 1,6
27	-----	-	-	-	
28	50139900	1	1	1	D1 23,3 x 2,4
29	50128900	4	8	14	M 8 x 16 DIN 912-8.8
30	03469200	1	2	3	
31	-----	-	-	-	



M 01

Kurbelgehäuse  
Crankcase  
Carter moteur  
Caja cigüeñal  
Basamento motore

Tafel Nr.  
Tabl. No.  
Tavola N.

04

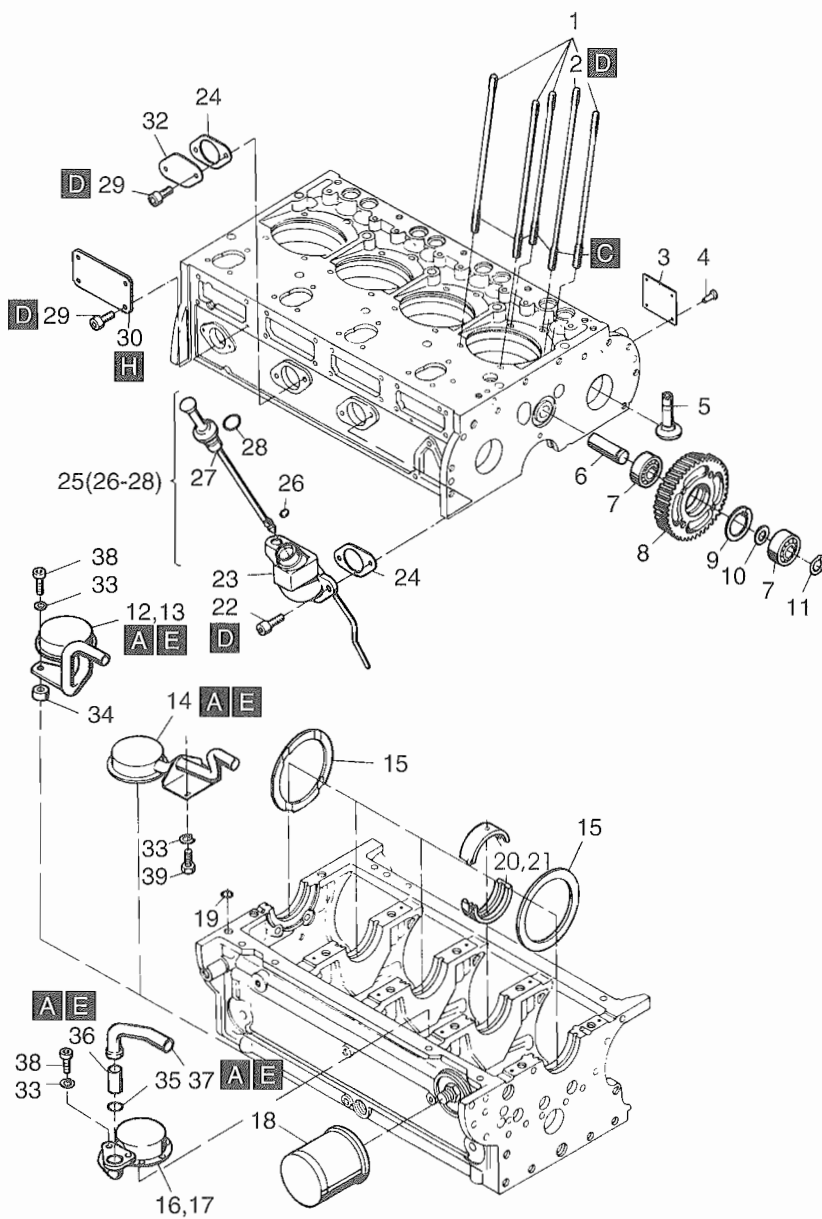

Fig.- No.	HATZ Ident-No.	Stück Qty.			P / W d / D	Bemerkungen Notes
		2 M . .	3 M . .	4 M . .		
32	03263300	-	-	1		
33	50002800	2	2	2	8	DIN 128
34	03467000	2	2	-		
35	50258000	1	1	-	}	f.Taf./Tabl.32, Pos.42,43,58,59
36	03617600	1	1	-		
37	03616500	1	1	-		
38	50051900	2	2	-	M 8 x 20	DIN 912-8.8
39	50026700	-	-	2	M 8 x 16	DIN 933-8.8

M 01

Massenausgleich  
Compensation of masses  
Equilibrage des masses  
Compensación de las masas  
Masse controrotanti

Tafel Nr.  
Tabl. No.  
Tavola N.

05

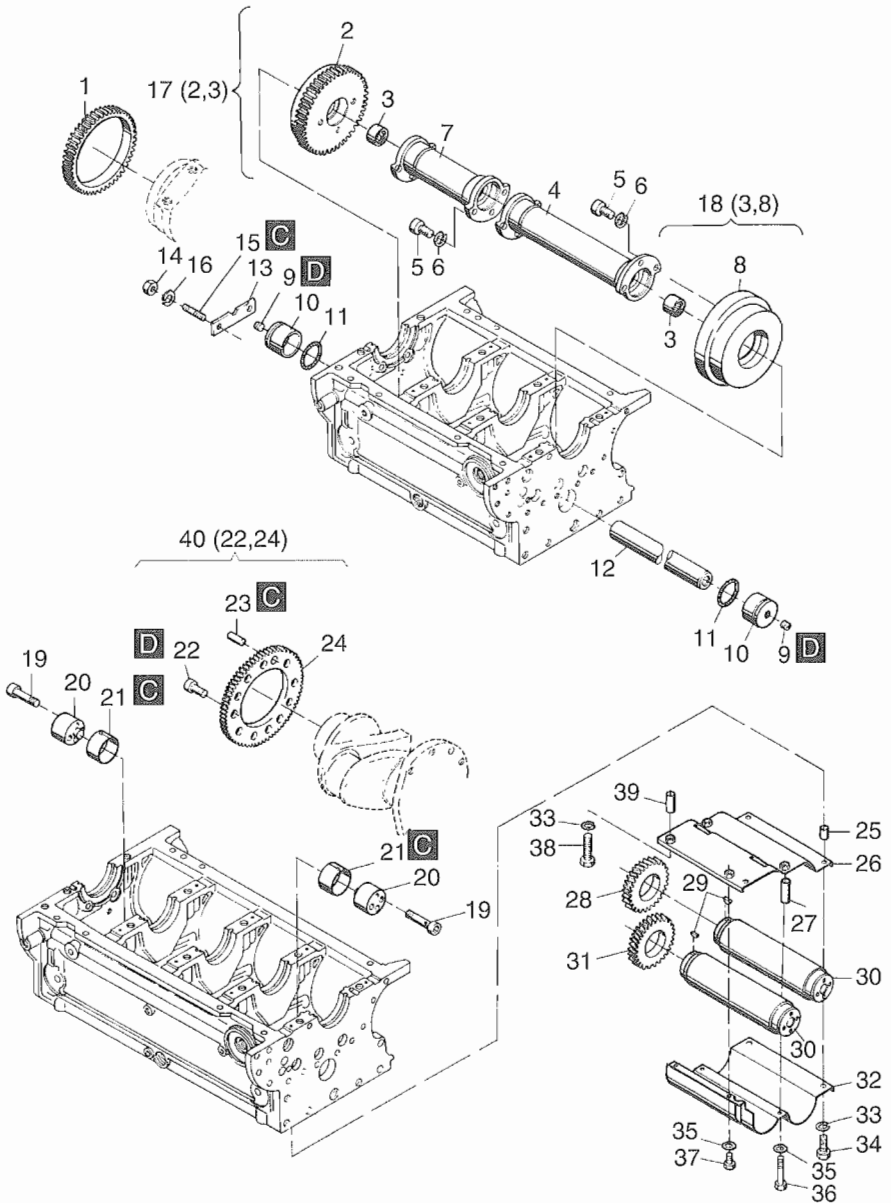

Fig.- No.	HATZ Ident-No.	Stück Qty.			P / W d / D	Bemerkungen Notes
		2M .. Z	3M .. Z	4M .. Z		
1	03553300	1	1	-		
2	-----	-	-	-		
3	50128500	2	2	-		
4	03553000	1	1	-		
5	50052000	6	9	-	M 8 x 20	DIN 6912-8.8
6	50128200	6	9	-	8	DIN 128
7	03568300	-	1	-		
8	-----	-	-	-		
9	50043600	2	2	-	M 10 x 1	DIN 906
10	03463400	2	2	-		
11	50132200	2	2	-	33,3 x 2,4	
12	03590000	-	1	-		
12	03463500	1	-	-		
13	03462900	1	1	-		
14	50022900	2	2	-	M 8	DIN 934-8
15	50240800	2	2	-	M 8 x 12	DIN 938-8.8
16	50002800	2	2	-	8	DIN 128
17	00902000	1	1	-		
18	00901900	1	1	-		
19	50127900	-	-	16	M 8 x 40	DIN 912-10.9
20	03627000	-	-	4		
21	03627201	-	-	4		
22	50418800	-	-	8	M 10 x 20	DIN 912-12.9
23	50111500	-	-	1	10 m 6 x 20	DIN 7-St.
24	01508200	-	-	-		
25	03599600	-	-	2		
26	00917800	-	-	1		
27	03599800	-	-	2		
28	03553403	-	-	1		
29	50017700	-	-	2	4 x 5	DIN 6888
30	00935600	-	-	2		
31	03553603	-	-	1		
32	03599200	-	-	1		
33	50002800	-	-	4	8	DIN 128
34	50051900	-	-	2	M 8 x 20	DIN 912-8.8
35	50081200	-	-	4	A 6	DIN 137
36	50073700	-	-	2	M 6 x 45	DIN 931-8.8
37	50050600	-	-	2	M 6 x 12	DIN 931-8.8
38	50052100	-	-	2	M 8 x 25	DIN 912-8.8
39	03599700	-	-	2		
40	01508200	-	-	1		

M 02

Kurbelwelle  
Crankshaft  
Vilebrequin  
Cigüeñal  
Albero a gomito

Tafel Nr.  
Tabl. No.  
Tavola N.

06

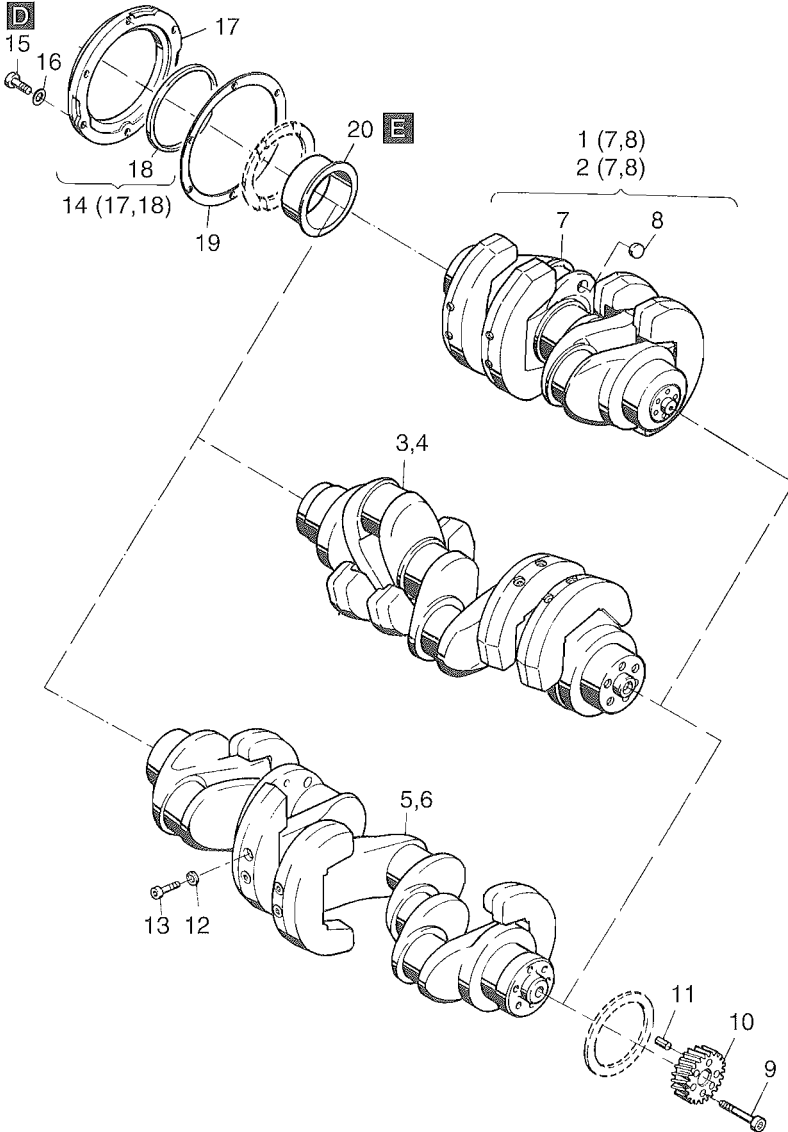

Fig.- No.	HATZ Ident-No.	Stück Qty.			P / W d / D	Bemerkungen Notes
		2 M ..	3 M ..	4 M ..		
1	00972700	1	-	-		2 M 31
2	00950801	1	-	-		2 M 40 – 2 M 41
3	00990200	-	1	-		3 M 31
4	00955000	-	1	-		3 M 40 – 3 M 41
5	00994800	-	-	1		4 M 31
6	00956300	-	-	1		4 M 40 – 4 M 41
7	-----	-	-	-		
8	50207200	2	-	-		2 M 4. 36 DIN 443
9	50127900	6	6	6		M 8 x 40 DIN 912-10.9
10	03561601	1	1	1		
11	50128000	1	1	1		11 x 10 DIN 7346 55SI 7
12	50002900	8	8	8		10 DIN 128
13	50132800	8	8	8		M 10 x 40 DIN 912-10.9
14	00957500	1	1	1		
15	50236600	6	6	6		M 6 x 25 DIN 912-8.8
16	50081200	6	6	6		A 6 DIN 137
17	-----	-	-	-		
18	50224601	1	1	1	D1	80 x 100 x 10
19	03550601	1	1	1	D1	
20	03780600	0...1	0...1	0...1		80 mm

Nockenwelle, Regler, Spritzversteller  
Camshaft, governor, timer

Tafel Nr.  
Tabl. No.  
Tavola N.

**M 04**

Arbre à cames, regulateur regime, variateur d'avance  
Arbol de levas, regulador, variador de avance  
Albero a camme, regolatore di giri, variatore di anticipo

**07**

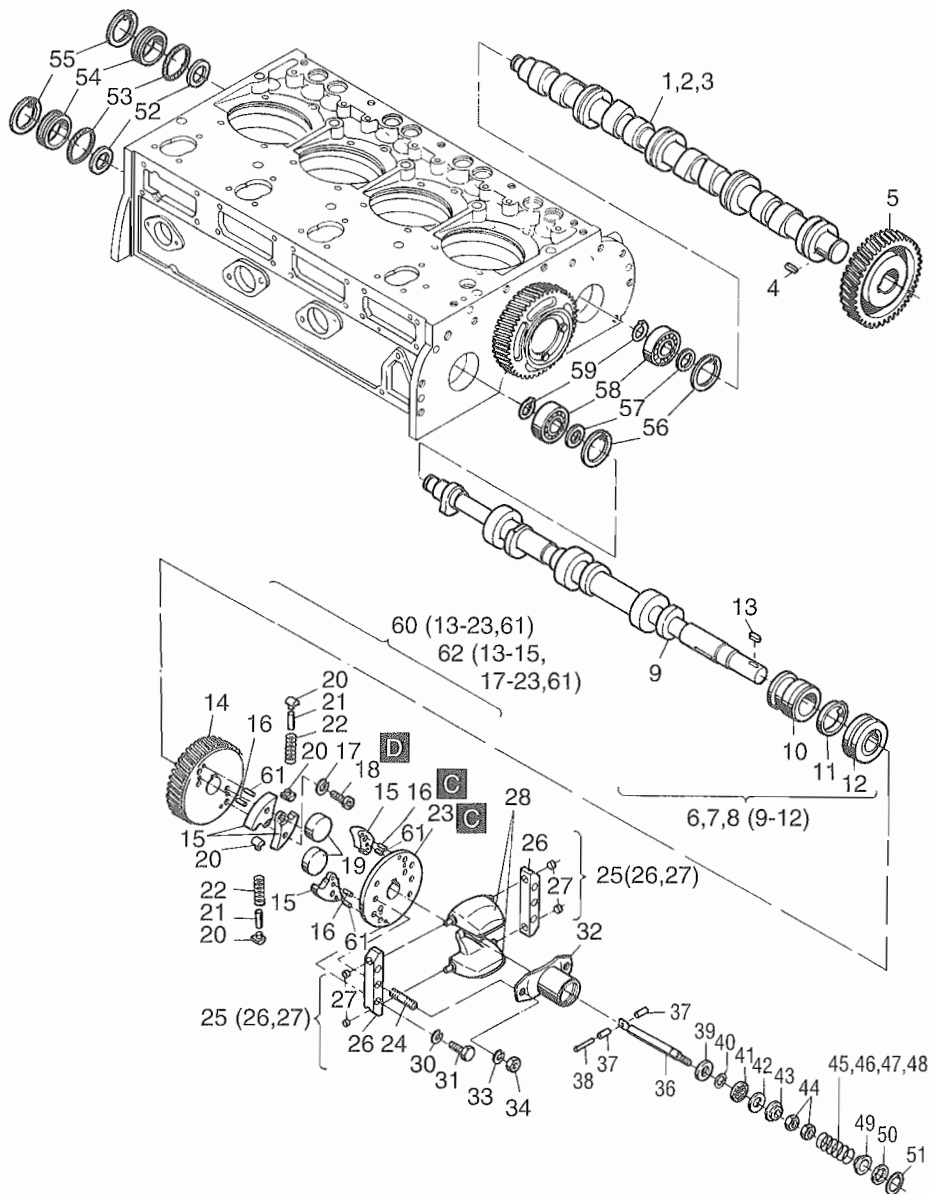

Fig.- No.	HATZ Ident-No.	Stück Qty.			P / W d / D	Bemerkungen Notes
		2 M . .	3 M . .	4 M . .		
1	03556700	1	-	-	(L)	2M31-40 L, 2M41
1	03779400	1	-	-	(H)	2M31-40 H
2	03555700	-	1	-	(L)	3M31-40 L, 3M41
2	03779500	-	1	-	(H)	3M31-40 H
3	03558000	-	-	1	(L)	4M31-40 L, 4M41
3	03779600	-	-	1	(H)	4M31-40 H
4	50011300	1	1	1		A 8 x 7 x 22 DIN 6885
5	03561800	1	1	1		
6	01212000	1	-	-		2M31-40
6	01544400	1	-	-		2M41
7	01212100	-	1	-		3M31-40
7	01544500	-	1	-		3M41
8	01212200	-	-	1		4M31-40
8	01544600	-	-	1		4M41
9	-----	-	-	-		
10	-----	-	-	-		
11	03576501	1	1	1		
12	-----	-	-	-		
13	50131600	1	1	1		A 6 x 6 x 20 DIN 6885 ST6
14	03561910	1	1	1		
14	04109700	1	1	1		.M41
15	03462701	4	4	4		
15	04109400	4	4	4		.M41
16	50057900	4	4	4		4 m 6 x 8 DIN 7-9S 20K
17	50140101	8	8	8		6 DIN 7980 (M31-M40)
18	50143200	8	8	8		M 6 x 18 DIN 6912-10.9
19	03460100	2	2	2		
19	01321900	2	2	2		.M41
20	03464500	4	4	4		
20	04109600	4	4	4		.M41
21	03561300	2	2	2		
21	04109500	2	2	2		.M41
22	03561400	2	2	2		
22	04109800	2	2	2		.M41
23	03554710	1	1	1		
23	04109300	1	1	1		.M41
24	50131500	2	2	2		M 8 x 30 DIN 938-8.8



Nockenwelle, Regler, Spritzversteller  
 Camshaft, governor, timer  
**M 04** Arbre à cames, regulateur regime, variateur d'avance  
 Arbol de levas, regulador, variador de avance  
 Albero a camme, regolatore di giri, variatore di anticipo

Tafel Nr.  
 Tabl. No.  
 Tavola N.  
**07**

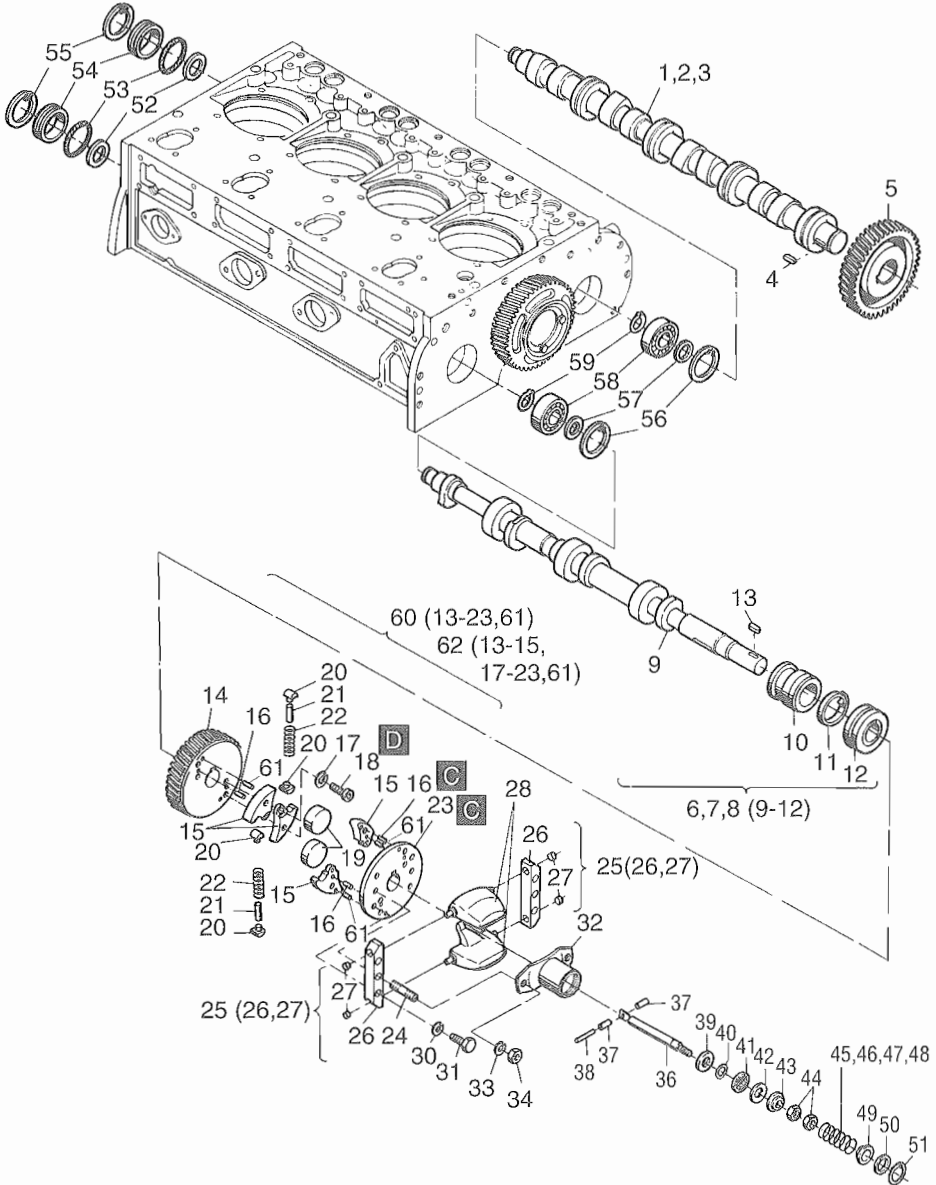

Fig.- No.	HATZ Ident-No.	Stück Qty.			P / W d / D	Bemerkungen Notes
		2 M . .	3 M . .	4 M . .		
25	00745800	2	2	2		.M31--M40
26	04112400	2	2	2		.M41
27	03572100	4	4	4		.M31--M40
28	03572900	2	2	2		
30	50347301	4	4	4		VHZ 8 A3C
31	50027000	4	4	4		M 8 x 25 DIN 938-8.8
32	03773101	1	1	1		
33	40027800	2	2	2		8
34	50022900	2	2	2		M 8 DIN 934-8
35	-----	-	-	-		
36	03772600	1	1	1		
37	03772500	2	2	2		
38	03576400	1	1	1		
39	03772701	1	1	1		
40	50268000	1	1	1		6 x 12 x 0,5 DIN 988
41	50268100	1	1	1		AXK 1024
41	04117900	1	1	1		.M41
42	50268200	1	1	1		AS 1024
43	03772800	1	1	1		
44	50144400	2	2	2		M 6 DIN 934-8 A3C
45	03601401	0...1	0...1	0...1		2,5 mm Ø 1500 min <sup>-1</sup> Gen.
46	03601301	0...1	0...1	0...1		2,6 mm Ø 1800 min <sup>-1</sup> Gen.
47	03601201	0...1	0...1	0...1		3,0 mm Ø ≤ 2300 min <sup>-1</sup>
48	03574401	0...1	0...1	0...1		3,2 mm Ø > 2300 min <sup>-1</sup> 3000 min <sup>-1</sup> Gen.
49	03571900	1	1	1		
50	03772900	1	1	1		
51	50021000	1	1	1		J 32 x 1,2 DIN 472
52	50132700	0...4	0...4	0...4		37 x 47 x 0,1 DIN 988
52	50277300	0...1	0...1	0...1		37 x 47 x 0,5 DIN 988
53	50130700	2	2	2	D2	42 x 2,5
54	03469700	2	2	2		
55	50021700	2	2	2		47 x 1,75 DIN 472
56	50021700	2	2	2		47 x 1,75 DIN 472
57	50132900	0...3	0...3	0...3		20 x 28 x 0,1 DIN 988
58	50013700	2	2	2		C 3 6204 DIN 625
59	50127600	2	2	2		AS 20 x 1,75 DIN 471
60	00919401	1	1	1		.M31-40
61	04092300	4	4	4		6 x 6,52 x 9 .M31-40
61	50140000	8	8	8		8 x 8 DIN 7346 .M41
62	01323800	1	1	1		.M41

M 04

Drehzahlverstellung  
Speed control  
Reglage regime  
Ajuste de revoluciones  
Comando acceleratore

Tafel Nr.  
Tabl. No.  
Tavola N.

08

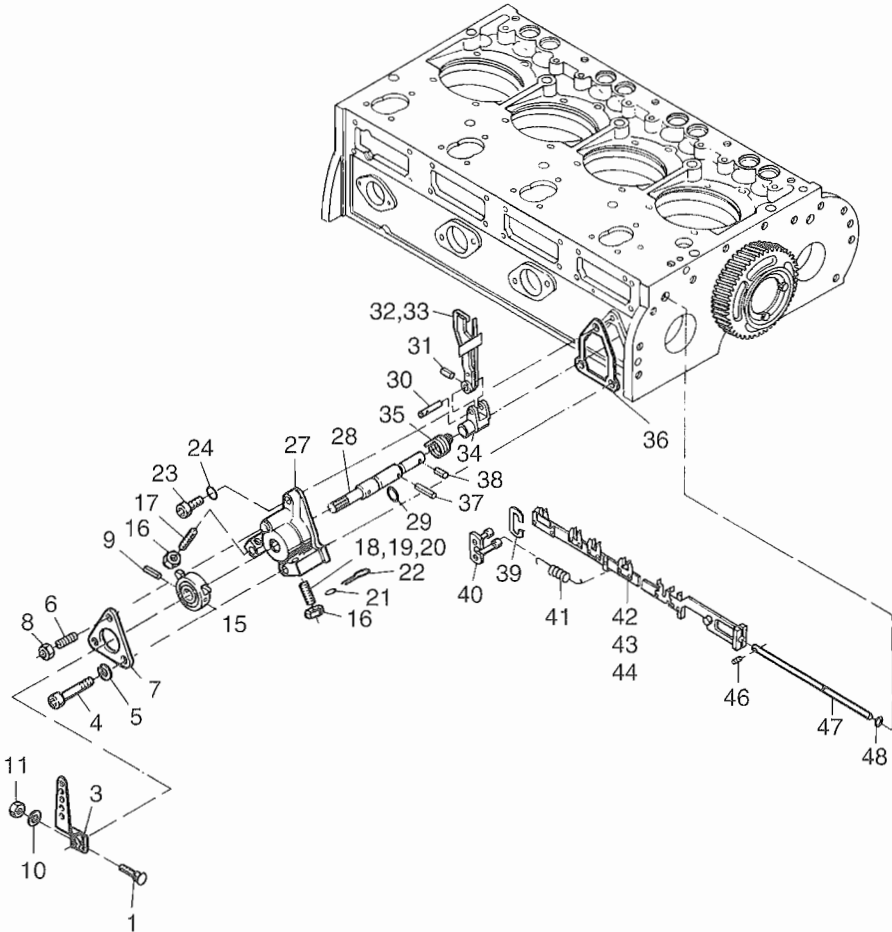

Fig.- No.	HATZ Ident-No.	Stück Qty.			P / W d / D	Bemerkungen Notes
		2 M . .	3 M . .	4 M . .		
1	03927300	1	1	1		M 6 x 32
2	-----	-	-	-		
3	03888300	1	1	1		
4	50053000	2	2	2		M 8 x 70 DIN 912-8.8
5	50002800	2	2	2		8 DIN 128
6	50279200	1	1	1		M 8 x 40 DIN 835-8.8 A3C
7	03465800	1	1	1		
8	40028400	1	1	1		V M 8 DIN 980-8 C3A
9	50035000	1	1	1		5 x 40 DIN 1481
10	50144500	1	1	1		6,4 DIN 125 A3C
11	50144400	1	1	1		M 6 DIN 934-8 A3C
12	-----	-	-	-		
13	-----	-	-	-		
14	-----	-	-	-		
15	03468810	1	1	1		
16	50022900	2	2	2		M 8 DIN 934-8
17	03245900	1	1	1		AM 8 x 35
18	03245900	0...1	0...1	0...1		AM 8 x 35 n >2600 min <sup>-1</sup>
19	03642900	0...1	0...1	0...1		AM 8 x 45 n=2200..2600 min <sup>-1</sup>
19	03774000	0...1	0...1	0...1		AM 8 x 40 n=2200..2600 min <sup>-1</sup>
20	03169501	0...1	0...1	0...1		AM 8 x 50 n < 2200 min <sup>-1</sup>
21	40021400	1	1	1		
22	40021500	1	1	1		
23	50051900	1	1	1		M 8 x 20 DIN 912-8.8
24	50162900	1	1	1		A 8 x 14 DIN 7603-Cu
25	-----	-	-	-		
26	-----	-	-	-		
27	03554220	1	1	1		
28	03468940	1	1	1		
29	40081700	1	1	1	D1	12 x 2
30	03469010	1	1	1		
31	50127500	1	1	1		3 x 14 DIN 1481
32	-----	-	-	-		
33	01213800	1	1	1		Nr. 1
33	01538600	1	1	1		Nr. 7
33	01555100	1	1	1		Nr. 8
33	01561400	1	1	1		Nr. 9
33	01561500	1	1	1		Nr. 10
33	01561600	1	1	1		Nr. 11
33	01086200	1	1	1		Nr. 12
34	03469120	1	1	1		

M 04

Drehzahlverstellung  
Speed control  
Reglage regime  
Ajuste de revoluciones  
Comando acceleratore

Tafel Nr.  
Tabl. No.  
Tavola N.

08

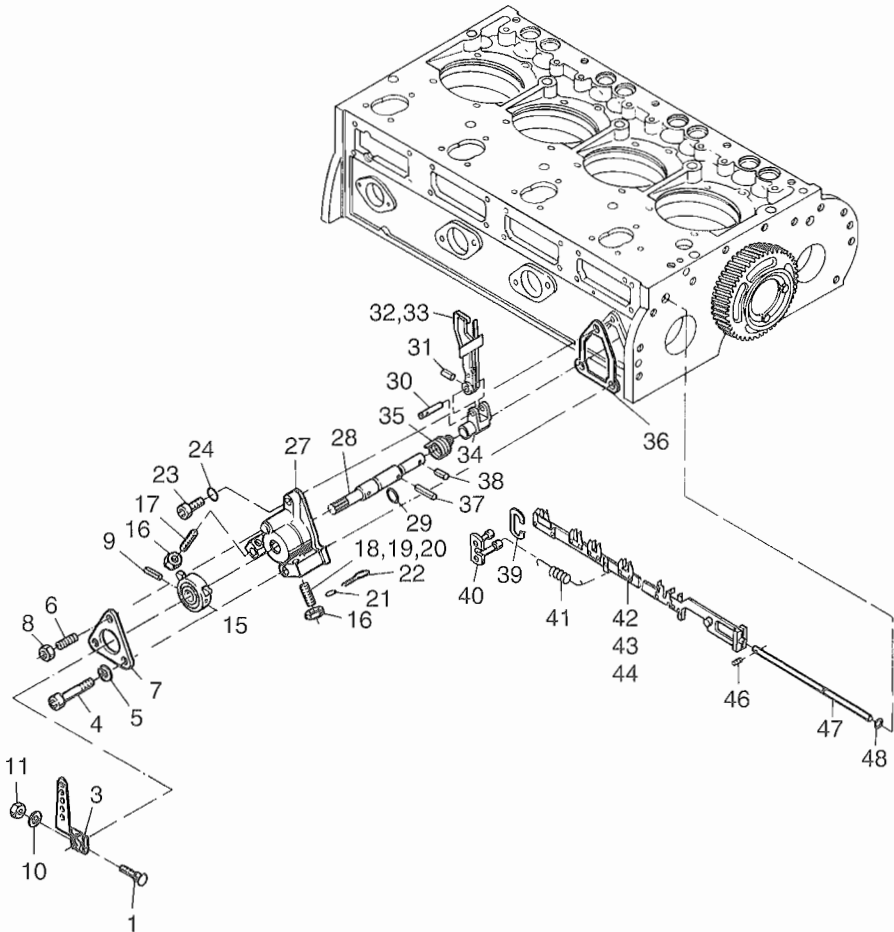

Fig.- No.	HATZ Ident-No.	Stück Qty.			P / W d / D	Bemerkungen Notes	
		2 M ..	3 M ..	4 M ..			
35	03861400	1	1	1			
36	03465900	1	1	1	D1		
37	50269000	1	1	1		4 x 26	DIN 1481
38	50131900	1	1	1		4 x 12	DIN 1481
39	03865010	0...3	0...3	0...3			
40	01066701	1	1	1			
41	03468100	1	1	1			
42	01066802	1	-	-			
43	01066902	-	1	-			
44	01067002	-	-	1			
46	50131800	1	1	1		2,5 x 10	DIN 1481
47	03460600	1	1	1			
48	40022300	1	1	1	D1		

**M 05**

Kolben, Pleuel  
Piston, conrod  
Piston, bielle  
Embolo, biela  
Pistone, biella

**M 06**

Zylinder  
Cylinder  
Cilindro  
Cilindro

Tafel Nr.  
Tabl. No.  
Tavola N.

**09**

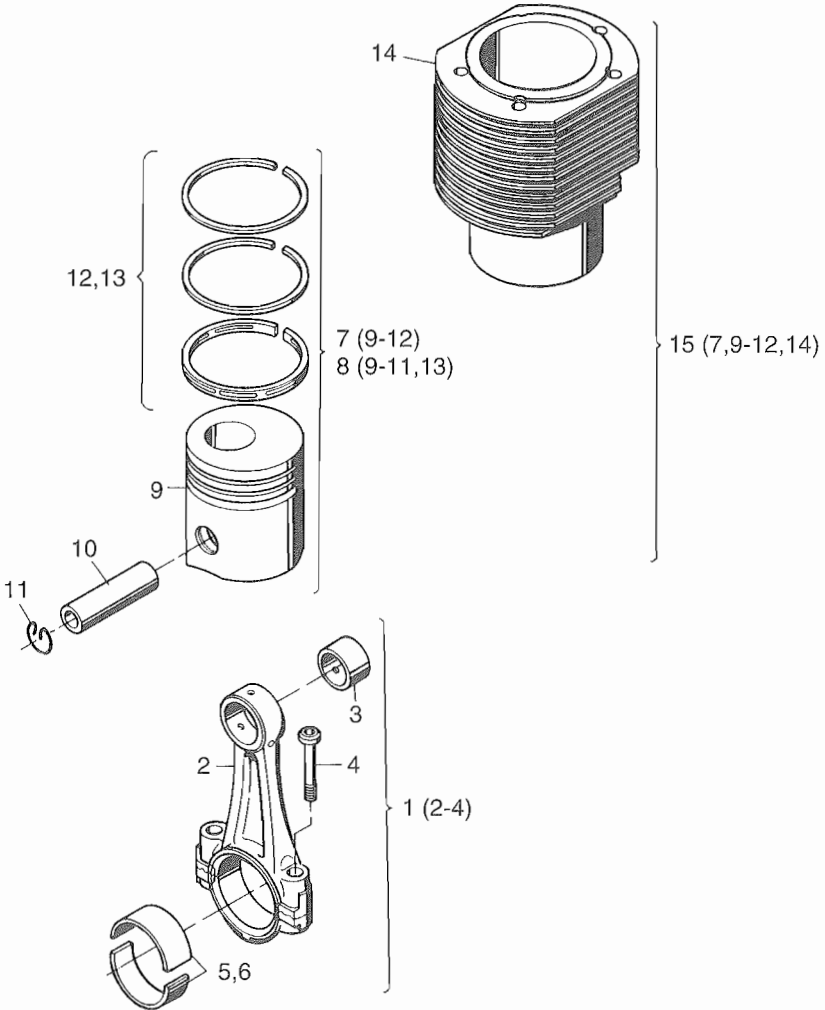

Fig.- No.	HATZ Ident-No.	Stück Qty.						P / W d / D	Bemerkungen Notes
		2 M 31	3 M 31	4 M 31	2 M 40	3 M 40	4 M 40		
1	00929702	2	3	4	2	3	4		
2	-----	-	-	-	-	-	-		
3	03753000	2	3	4	2	3	4		
4	03775200	4	6	8	4	6	8		
5	03618401	2	3	4	2	3	4		
6	03753100	2	3	4	2	3	4	- 0,5 mm	
7	01213601	2	3	4	-	-	-	.M31	
7	00954103	-	-	-	2	3	4	.M40	
7	01322802	-	-	-	2	3	4	.M41	
8	01235901	2	3	4	-	-	-	+ 0,5 mm .M31	
8	01235702	-	-	-	2	3	4	+ 0,5 mm .M40	
8	01323002	-	-	-	2	3	4	+ 0,5 mm .M41	
9	-----	-	-	-	-	-	-		
10	50236100	2	3	4	2	3	4		
11	50349100	4	6	8	4	6	8	BS 36/3	
12	00955800	2	3	4	2	3	4		
13	01235800	2	3	4	2	3	4	+ 0,5 mm	
14	-----	-	-	-	-	-	-		
15	01218200	2	3	4	-	-	-	.M31	
15	00973401	-	-	-	2	3	4	.M40	
15	01544700	-	-	-	2	3	4	.M41	



M 07

Zylinderkopf  
Cylinder head  
Culasse  
Culata  
Testa

Tafel Nr.  
Tabl. No.  
Tavola N.

10

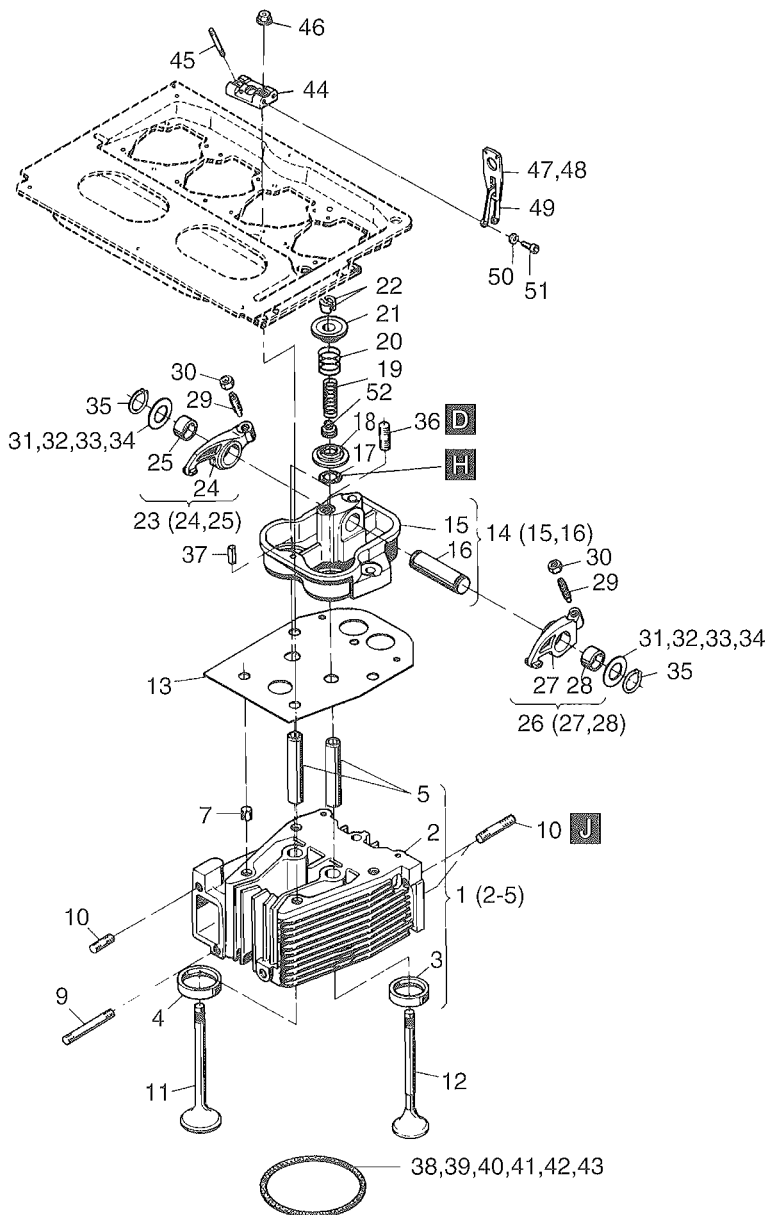

Fig.- No.	HATZ Ident-No.	Stück Qty.			P / W d / D	Bemerkungen Notes
		2 M ..	3 M ..	4 M ..		
1	00933001	2	3	4		„L“
1	00993600	2	3	4		„H“
1	01317500	2	3	4		.M41
2	-----	-	-	-		
3	-----	-	-	-		
4	-----	-	-	-		
5	04037700	4	6	8		
6	-----	-	-	-		
7	04103700	8	12	16		13 x 14
8	-----	-	-	-		
9	50132500	2	3	4		M 8 x 65 DIN 835-8.8
10	50128100	6	9	12		M 8 x 30 DIN 835-10.9
11	03625501	2	3	4		.M31-.M40
11	04108400	2	3	4		.M41
12	03625600	2	3	4		.M31-.M40
12	04108500	2	3	4		.M41
13	03624801	2	3	4		
14	00956200	2	3	4		
15	-----	-	-	-		
16	03469800	2	3	4		
17	50288100	4	6	8	d2	15,3 x 3,2
18	03393010	4	6	8		
19	03183500	4	6	8		.M31-.M40 „L“, .M41
20	03325600	4	6	8		.M31-.M40 „L, H“, .M41
21	03043402	4	6	8		
22	03620900	4	6	8		
23	00532500	2	3	4		
24	-----	-	-	-		
25	03184100	2	3	4		
26	00932800	2	3	4		
27	-----	-	-	-		
28	03184100	2	3	4		
29	03772000	4	6	8		
30	03149000	4	6	8	W2	
31	03580600	0..4	0..6	0..8		0,15 mm
32	03233200	0..4	0..6	0..8		0,20 mm
33	03233300	0..4	0..6	0..8		0,30 mm
34	03456000	0..4	0..6	0..8		0,40 mm
35	50020200	4	6	8		19 x 1,2 DIN 471

M 07

Zylinderkopf  
Cylinder head  
Culasse  
Culata  
Testa

Tafel Nr.  
Tabl. No.  
Tavola N.

10

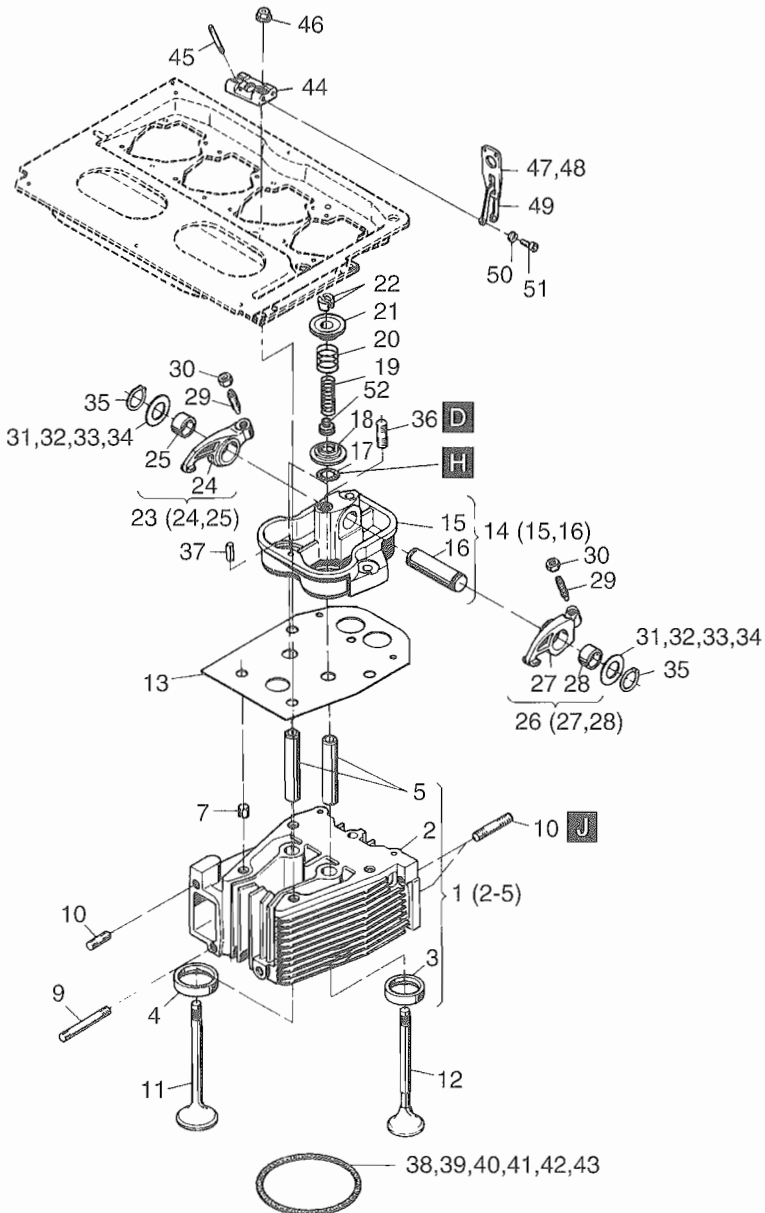

Fig.- No.	HATZ Ident-No.	Stück Qty.			P / W d / D	Bemerkungen Notes
		2 M ..	3 M ..	4 M ..		
36	50040500	2	3	4		M 10 x 25 DIN 939-5.6
37	50035200	2	3	4		6 x 12 DIN 1481
38	03625901	0...2	0...3	0...4		0,7 mm
39	03626001	0...2	0...3	0...4	d1	0,8 mm
40	03626101	0...2	0...3	0...4		0,9 mm
41	03626201	0...2	0...3	0...4	d1	1,0 mm
42	03626301	0...2	0...3	0...4		1,1 mm
43	03626401	0...2	0...3	0...4		1,2 mm
44	03624900	2	3	4		
44	04108600	2	3	4		.M41
45	50239000	4	6	8		M 8 x 55 DIN 933-8.8
46	03648100	10	15	20	P5	
47	-----	-	-	-		
48	-----	-	-	-		
49	03625000	1	1	1		
50	50128200	2	2	2		8 DIN 127
51	50129700	2	2	2		M 8 x 18 DIN 912-10.9
52	50284800	4	6	8	d2	

**M 08** Deckel z. Zyl.-Kopf  
 Cover cyl.-head  
 Couvercle culasse  
 Tapa culata  
 Coperchio bilanc.

**M 09** Stoßstange  
 Pushrod  
 Tige de culbuteur  
 Varilla de balacin  
 Asta bilancieri

**M 10** Ölpumpe  
 Oil pump  
 Pompe a huile  
 Bomba de aceite  
 Pompa olio

Tafel Nr.  
 Tabl. No.  
 Tavola N.  
**11**

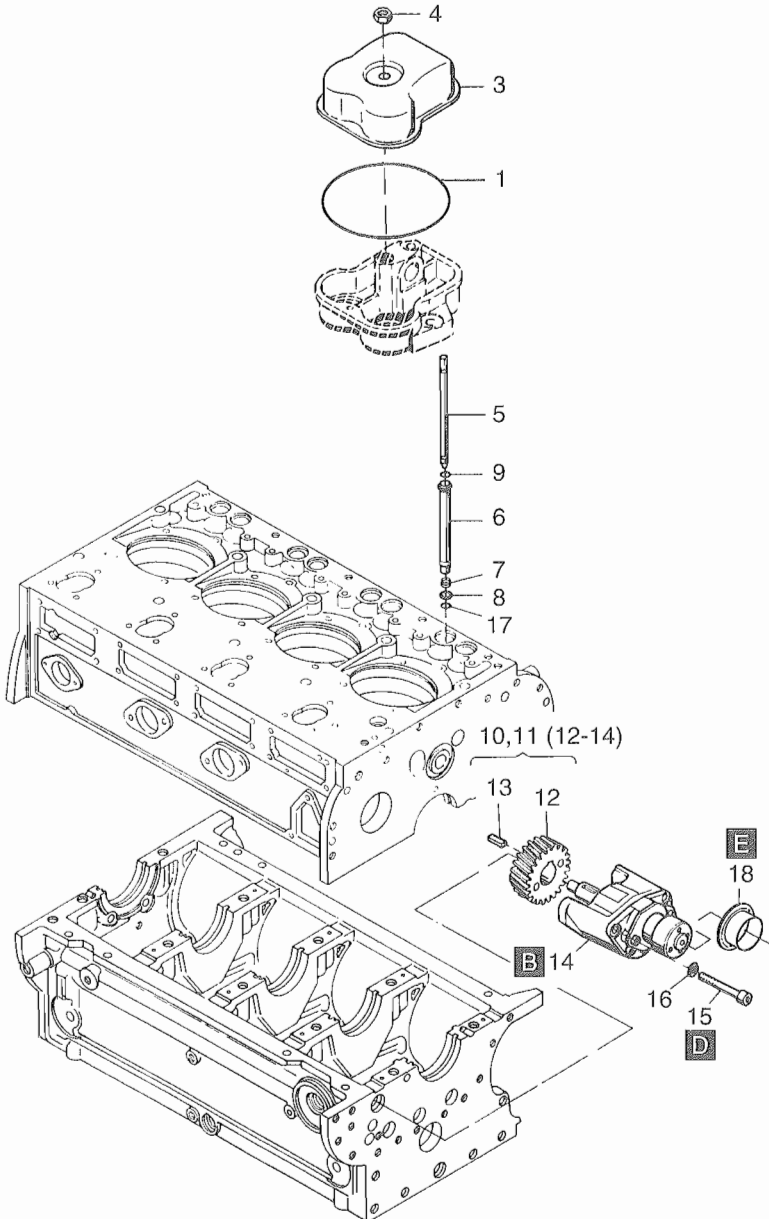

Fig.- No.	HATZ Ident-No.	Stück Qty.			P / W d / D	Bemerkungen Notes
		2 M ..	3 M ..	4 M ..		
1	50224900	2	3	4	W4/6/8 d1	123 x 2,5
2	-----	-	-	-		
3	03642601	2	3	4		
4	50132300	2	3	4	W2/3/4	M 10
5	00743600	4	6	8		
6	03566701	4	6	8		
7	03185100	4	6	8		
8	03185200	4	6	8		
9	50288000	4	6	8	d2	17 x 3
10	00924204	1	1	-		
11	00923904	-	-	1		
12	03562020	1	1	1		
13	50316800	1	1	1		4 x 4 x 20 DIN 6885
14	-----	-	-	-		
15	50206800	3	3	3		M 8 x 105 DIN 912-8.8
16	50002800	3	3	3		8 DIN 128
17	50288100	4	6	8	d2	15 x 3,2
18	50289400	0...1	0...1	0...1		55 mm

**M 11**

Steuergehäuse  
Timing cover  
Couvercle distribution  
Tapa de mando  
Coperchio distribuzione

Tafel Nr.  
Tabl. No.  
Tavola N.

**12**

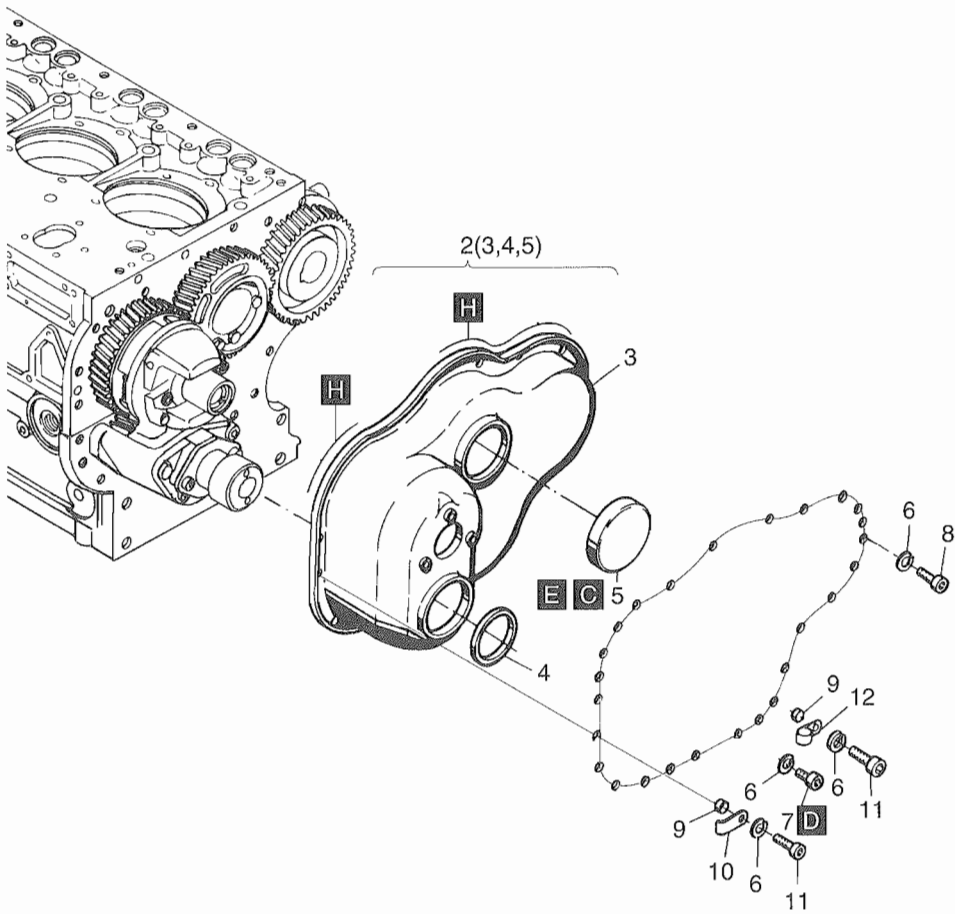

Fig.- No.	HATZ Ident-No.	Stück Qty.	P / W d / D	Bemerkungen Notes
		2..4M..		
1	-----	-		
2	00993200	1		
3	-----	-		
4	50129100	1	D1	55 x 70 x 8
5	50126500	1		70          DIN 442
6	50002800	22		8            DIN 128
7	50205800	4		M 8 x 12    DIN 912-8.8
8	50051600	15		M 8 x 16    DIN 912-8.8
9	03116700	3		
10	03159200	1		
11	50052100	3		M 8 x 25    DIN 912-8.8
12	03165500	2		



**M 12** Startfüllung  
 Extra fuel device  
 Sucharge  
 Sobre aliment.-arranque  
 Suplemento

Tafel Nr.  
 Tabl. No.  
 Tavola N.

**13**

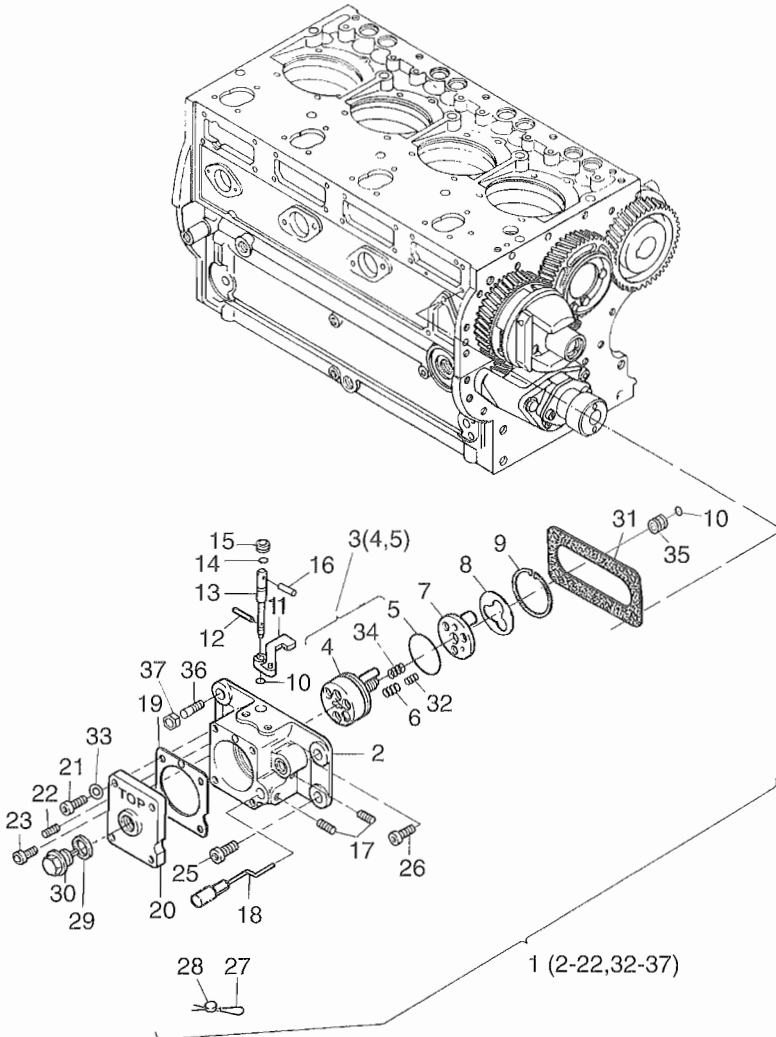

Fig.- No.	HATZ Ident-No.	Stück Qty.	P / W d / D	Bemerkungen Notes
		2..4M..		
1	01586900	1		
2	-----	-		
3	01201820	1		
4	-----	-		
5	50263100	1		37,8 x 1,5
6	03881100	3		
7	03854210	1		
8	03929700	1		
9	50021500	1		J 42 x 1,75
10	50117200	2	4	DIN 6799
11	03670210	1		
12	50131800	1		2,5 x 10 DIN 1481
13	03828810	1		
14	40021700	1		4,47 x 1,78
15	50324400	1		
16	50034300	1		3 x 36 DIN 1481
17	50262301	2		M 4 x 10 DIN 915-45H TU
18	01076210	1		
19	03934400	1		
20	01162100	1		
21	50416800	4		M 6 x 16 DIN 912-8.8 A3C
22	50262400	3		M 6 x 10 DIN 916-45H TU
23	50134900	1		M 8 x 16 DIN 6912-8.8
24	-----	-		
25	50128900	1		M 8 x 16 DIN 912-8.8
26	03960300	1		M 8 x 20
27	40021500	1		0,5/0,3
28	40021400	1		8 mm
29	50001200	1		A 14 x 18 DIN 7603-Cu
30	01097800	1		
31	03614001	1		
32	03935200	3		
33	50170900	4		6 DIN 128
34	03617800	1		
35	03841800	1		
36	04123900	1		M 8 x 19
37	40028400	1		VM 8 980-8 C3A

# M 13

Gebälse  
Blower  
Soufflerie  
Ventilador  
Ventilatore

Tafel Nr.  
Tabl. No.  
Tavola N.

14

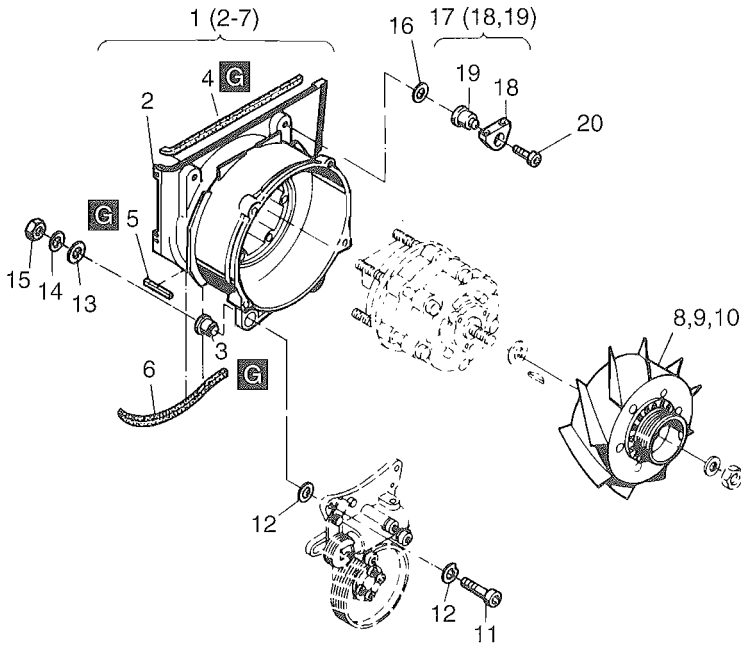

Fig.- No.	HATZ Ident-No.	Stück Qty.			P / W d / D	Bemerkungen Notes
		2 M ..	3 M ..	4 M ..		
1	00740202	1	1	-		
1	01203701	-	-	1		
2	-----	-	-	-		
3	03562500	2	2	2		
4	03552600	1	1	1		335 mm
5	03598500	1	1	1		33 mm
6	03552401	1	1	1		240 mm
7	-----	-	-	-		
8	00959000	1	-	-		
9	00989701	-	1	-		
10	00990011	-	-	1		
11	50055100	2	2	2		M 10 x 55 DIN 912-8.8
12	50061700	4	4	4		A 10 DIN 137
13	50070600	2	2	2		10,5 DIN 7349
14	50002900	2	2	2		10 DIN 128
15	50023500	2	2	2		M 10 DIN 934-8
16	03595600	0...4	0...4	0...4		
17	00919800	2	2	2		
18	-----	-	-	-		
19	03552600	2	2	2		
20	50052600	2	2	2		M 8 x 45 DIN 912-8.8

# M 14

Gebälse  
Blower  
Soufflerie  
Ventilador  
Ventilatore

Tafel Nr.  
Tabl. No.  
Tavola N.

15

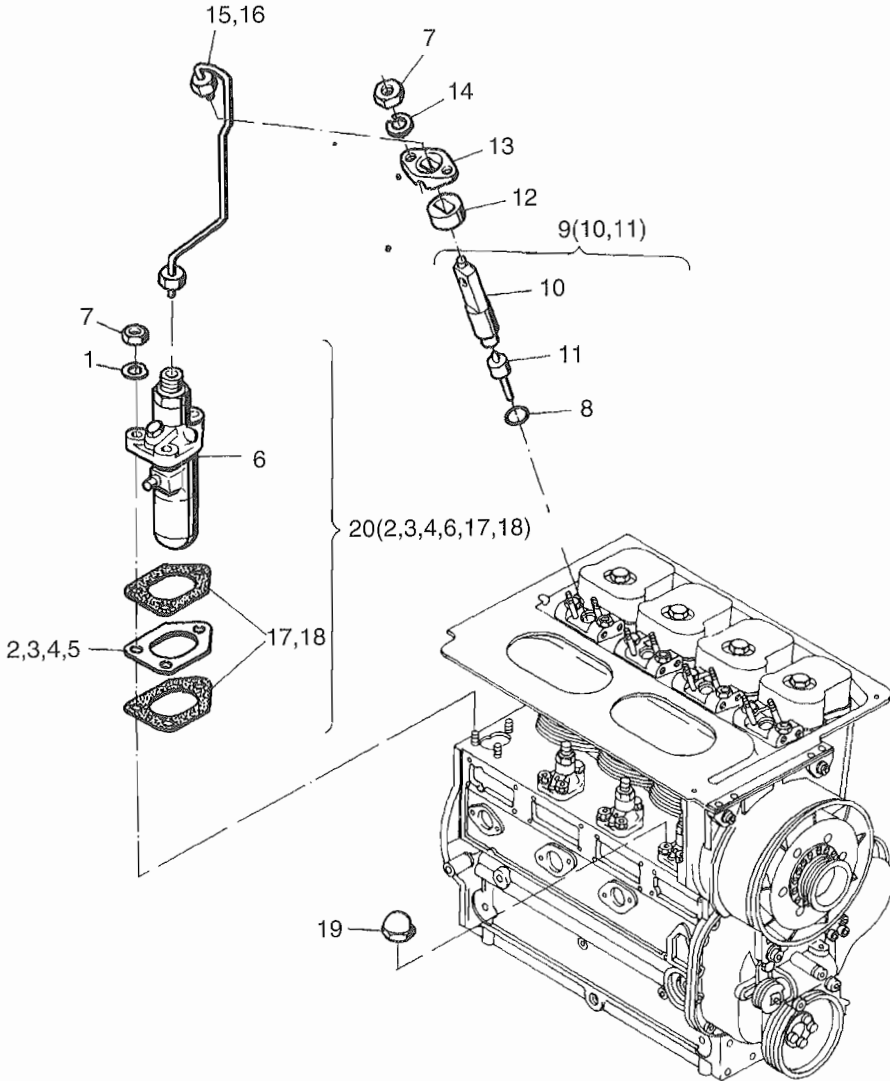

Fig.- No.	HATZ Ident-No.	Stück Qty.			P / W d / D	Bemerkungen Notes
		2 M..	3 M..	4 M..		
1	50003500	6	9	12		B 8          DIN 137
2	03168701	0...2	0...3	0...4		0,30 mm
3	03897100	0...2	0...3	0...4		0,60 mm
4	03897200	0...2	0...3	0...4		0,90 mm
5	03897300	0...2	0...3	0...4		1,20 mm
6	-----	-	-	-		
7	50022900	9	14	19	P4	M 8          DIN 934-8
8	40085001	2	3	4	d1	.M31--M40
8	04107300	2	3	4	d1	.M41
9	40120901	2	3	4		.M31-40
9	50444000	2	3	4		.M41
10	-----	-	-	-		
11	50141301	2	3	4	P1	.M31-40
11	50444100	2	3	4	P1	.M41
12	03466500	2	3	4		
13	03460500	2	3	4		
14	50128200	4	6	8	P4	8                  DIN 127
15	01203800	2	3	4		„L“ 2-4M..L, 2-4M41
16	00740600	2	3	4		„H“ 2-4M..H
17	03896802	0...4	0...6	0...8	D4	0,20 mm
18	03896902	0...4	0...6	0...8	D4	0,30 mm
19	50267600	1	1	1		M 8          DIN 1587
20	01268500	2	3	4		.M31-40
20	01544800	2	3	4		.M41

**M 16**

Riemenscheibe  
Pulley  
Poulie  
Polea  
Puleggia

**M 17**

Schwungrad  
Flywheel  
Volant  
Volante  
Volano

**M 20**

Hydr. Abst. v. v. r.  
Hydr. belt tensioner  
Tendeur hydr.  
Tensor hidr.  
Tendiciniglia idraulico

Tafel Nr.  
Tabl. No.  
Tavola N.  
**15**

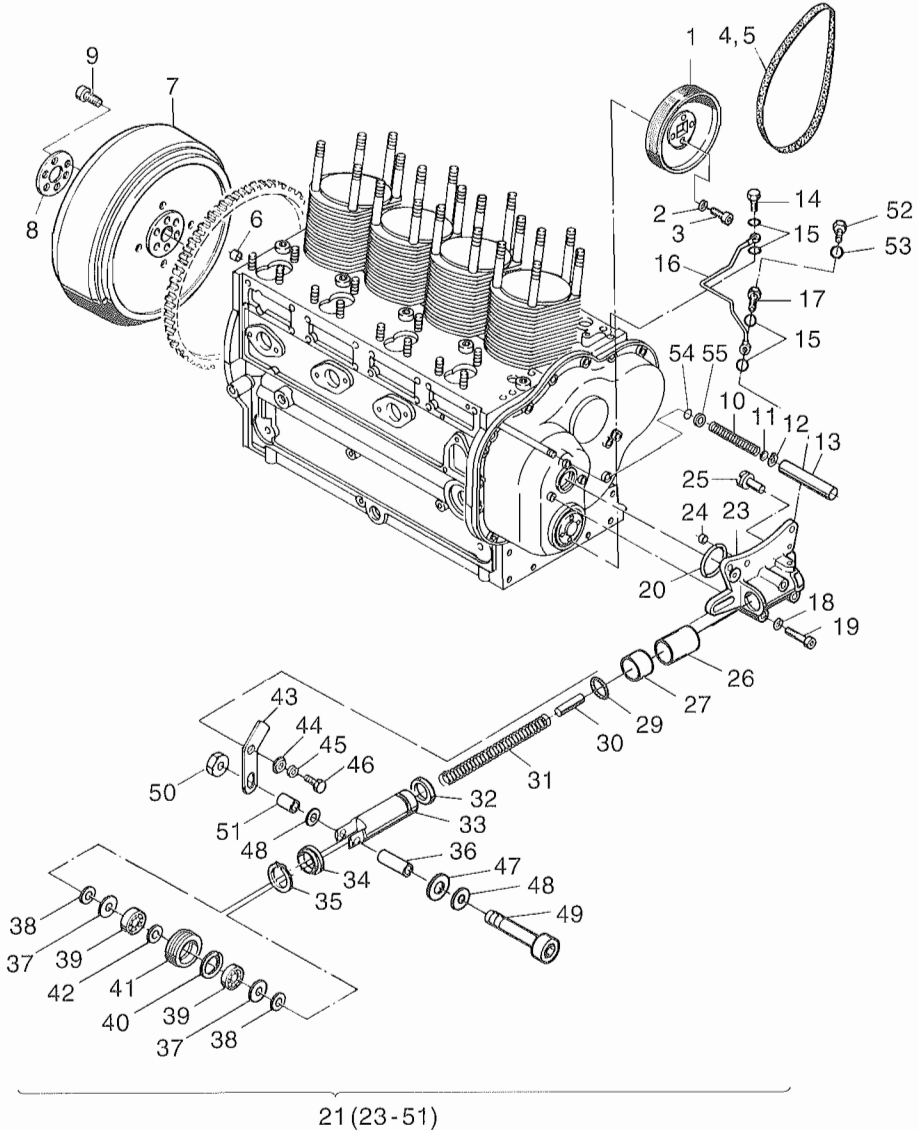

Fig.- No.	HATZ Ident-No.	Stück Qty.	P / W d / D	Bemerkungen Notes
2..4M..				
1	03589801	1		
2	50002800	4		8            DIN 128
3	50051900	4		M 8 x 20    DIN 931-8.8
4	50141500	1	P1	9 J 910
5	-----	-		
6	03630600	1		
7	03733701	1		SAE J 620
8	03645800	1		
9	50225100	6		M 14 x 1,5 x 45 DIN 912-10.9
10	03468000	1		
11	03133200	1		
12	50019400	1		8 x 0,8      DIN 471
13	03568200	1		
14	50006100	1		4-5-3        DIN 7643
15	50000900	4	D8	A 8 x 11,5    DIN 7603-Cu
16	00910000	1		
17	03724800	1		
18	50003500	3		B 8            DIN 137
19	50081800	3		M 8 x 65     DIN 912-8.8
20	50132401	1	D1	
21	00995502	1		
22	-----	-		
23	-----	-		
24	40084700	1		
25	-----	-		
26	50220900	1		
27	50220800	1		
28	-----	-		
29	50219700	1		
30	03639300	1		
31	03589100	1		
32	50221100	1		
33	03589622	1		
34	03643001	1		
35	50290400	1		JW 45 x 1,75 DIN 472
36	03764600	1		



M 16

Riemenscheibe  
Pulley  
Poulie  
Polea  
Puleggia

M 17

Schwungrad  
Flywheel  
Volant  
Volante  
Volano

M 20

Hydr. Abstellvorr.  
Hydr. belt tensioner  
Tendeur hydr.  
Tensor hidr.  
Tendiciniglia idraulico

Tafel Nr.  
Tabl. No.  
Tavola N.

15

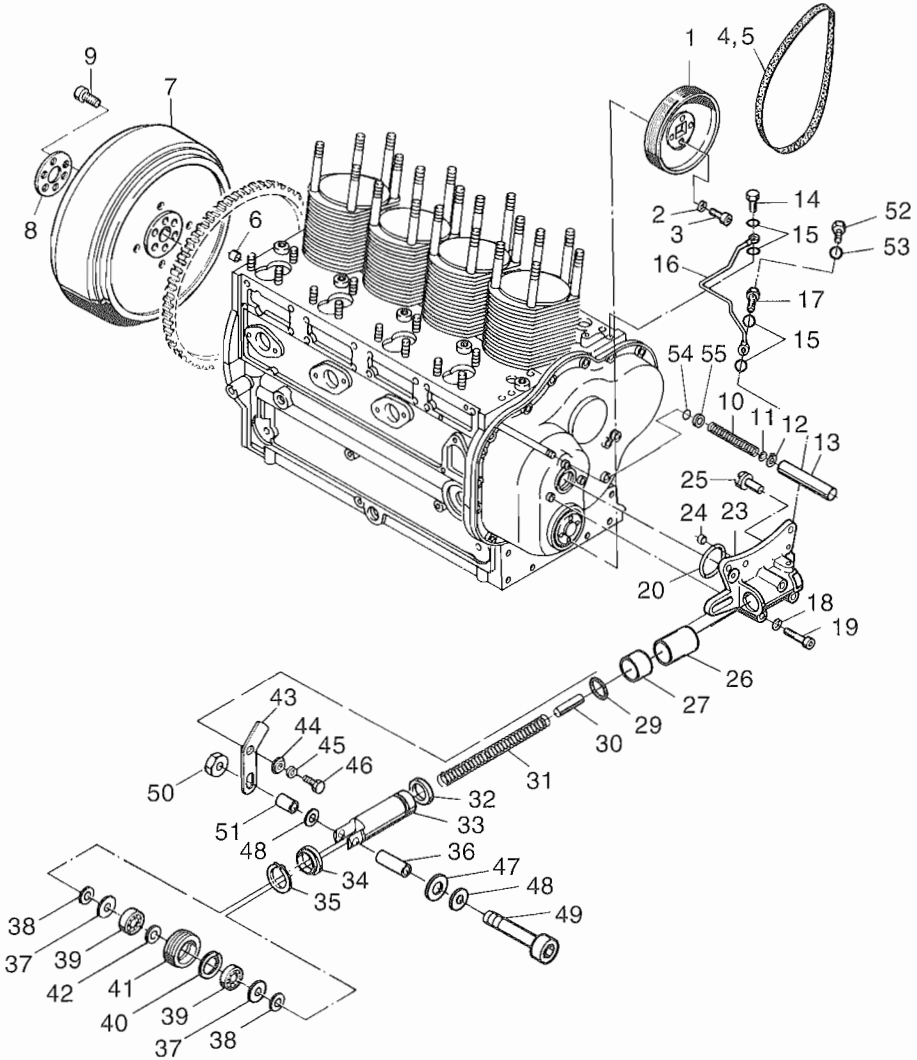

21(23-51)

Fig.- No.	HATZ Ident-No.	Stück Qty.	P / W d / D	Bemerkungen Notes
		2..4M..		
37	50250000	2		
38	03764800	2		
39	50249900	2		
40	50020700	1		J 28 x 1,2 DIN 472
41	03589421	1		
42	50132100	1		12 x 18 x 1,2
43	03589510	1		
44	03589300	1		
45	50002700	1		6 DIN 128
46	50025800	1		M 6 x 20 DIN 933-8.8
47	03764900	1		
48	50148100	2		A 8,4 DIN 125-St A3C
49	50081800	1		M 8 x 65 DIN 912-8.8
50	40028400	1		M 8 SSN 440-8 Cu
51	03764700	1		
52	50025300	1		M 6 x 8 DIN 933-8.8
53	50000800	1		A 6,5 x 9,5 DIN 7603-Cu
54	50346700	1		7,5 x 2,5
55	04102700	1		

M 22

Luftfilter  
Air filter  
Filtre à air  
Filtro de aire  
Filtro aria

M 27

Luftansaugrohr  
Air intake manifold  
Collecteur d'admission  
Tubo de aspiración  
Collettore aspirazione

Tafel Nr.  
Tabl. No.  
Tavola N.

17

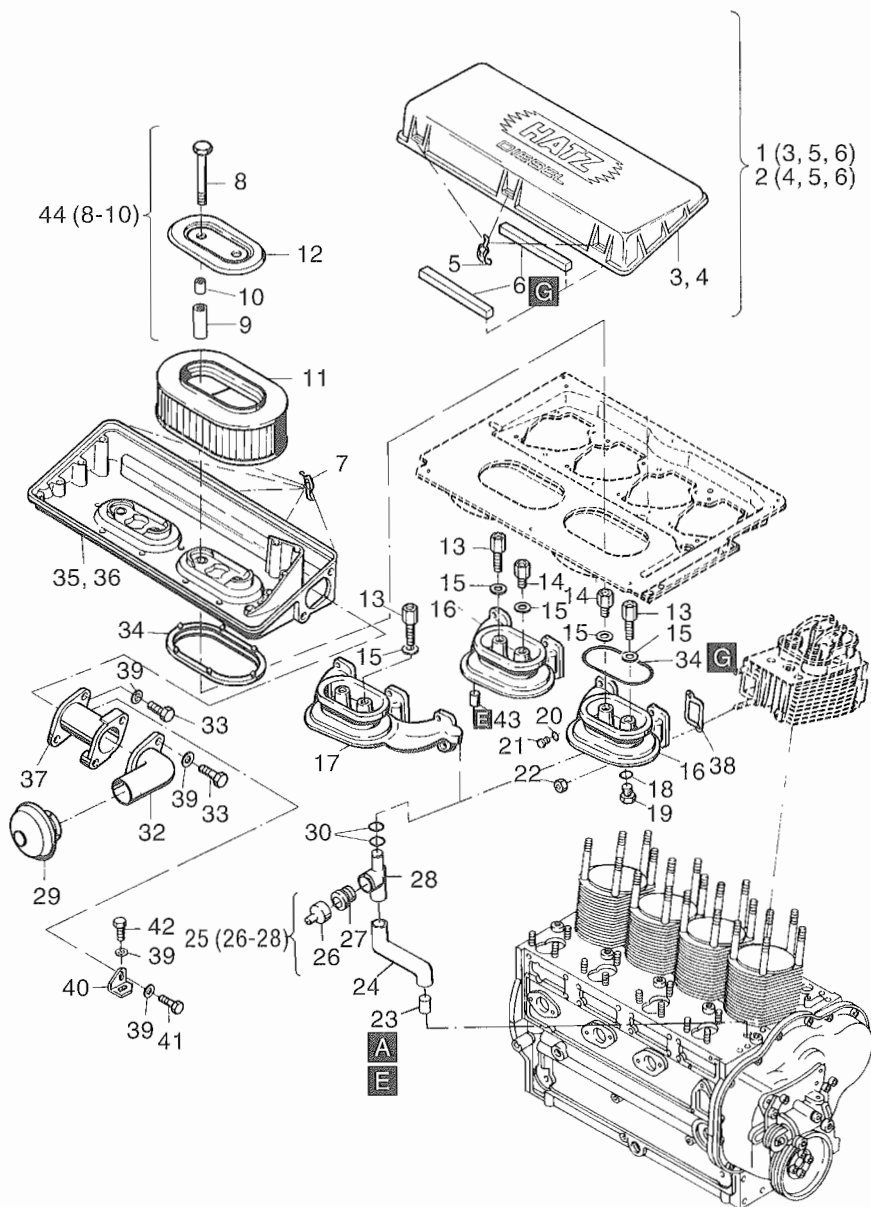

Fig.- No.	HATZ Ident-No.	Stück Qty.			P / W d / D	Bemerkungen Notes
		2 M . .	3 M . .	4 M . .		
1	01217800	1	1	-		
2	01218000	-	-	1		
3	-----	-	-	-		
4	-----	-	-	-		
5	01207800	2	2	3	P2	
6	03778900	2	2	4		
7	01207800	3	3	5		
8	-----	-	-	-		
9	-----	-	-	-		
10	04085700	2	2	4		10 x 7 x 10
11	00952900	1	1	2	W2/4	
12	01212600	1	1	2		
13	03778700	2	2	2		
14	03778600	-	-	2		
15	03171700	2	2	4		
16	03775401	1	-	2		
17	03775500	-	1	-		
18	50001600	1	1	2		A 22 x 27 DIN 7603-Cu
19	50140400	1	1	2		AM 22 x 1,5 DIN 7604
20	50062400	1	1	2	D3	A 10 x 13,5 DIN 7603-Cu
21	50062300	1	1	2		M 10 x 1 DIN 908
22	40028400	4	6	8	P4	VM 8 DIN 980-8 C3A
23	03649000	1	1	1		
24	03648900	1	1	1		
25	00947801	1	1	1		
26	03568600	1	1	1		
27	03568700	1	1	1		
28	-----	-	-	-		
29	50287900	1	1	1	P1	
30	50326700	2	2	2	D2	9,7 x 1
31	03779100	1	1	2		
32	03775100	1	1	1		
33	50148200	2	4	2		M 8 x 22 DIN 933-8.8 A3C
34	03778800	1	1	2		
35	01207900	1	1	-		
36	01207300	-	-	1		

M 22

Luftfilter  
Air filter  
Filtre à air  
Filtro de aire  
Filtro aria

M 27

Luftansaugrohr  
Air intake manifold  
Collecteur d'admission  
Tubo de aspiración  
Collettore aspirazione

Tafel Nr.  
Tabl. No.  
Tavola N.  
  
17

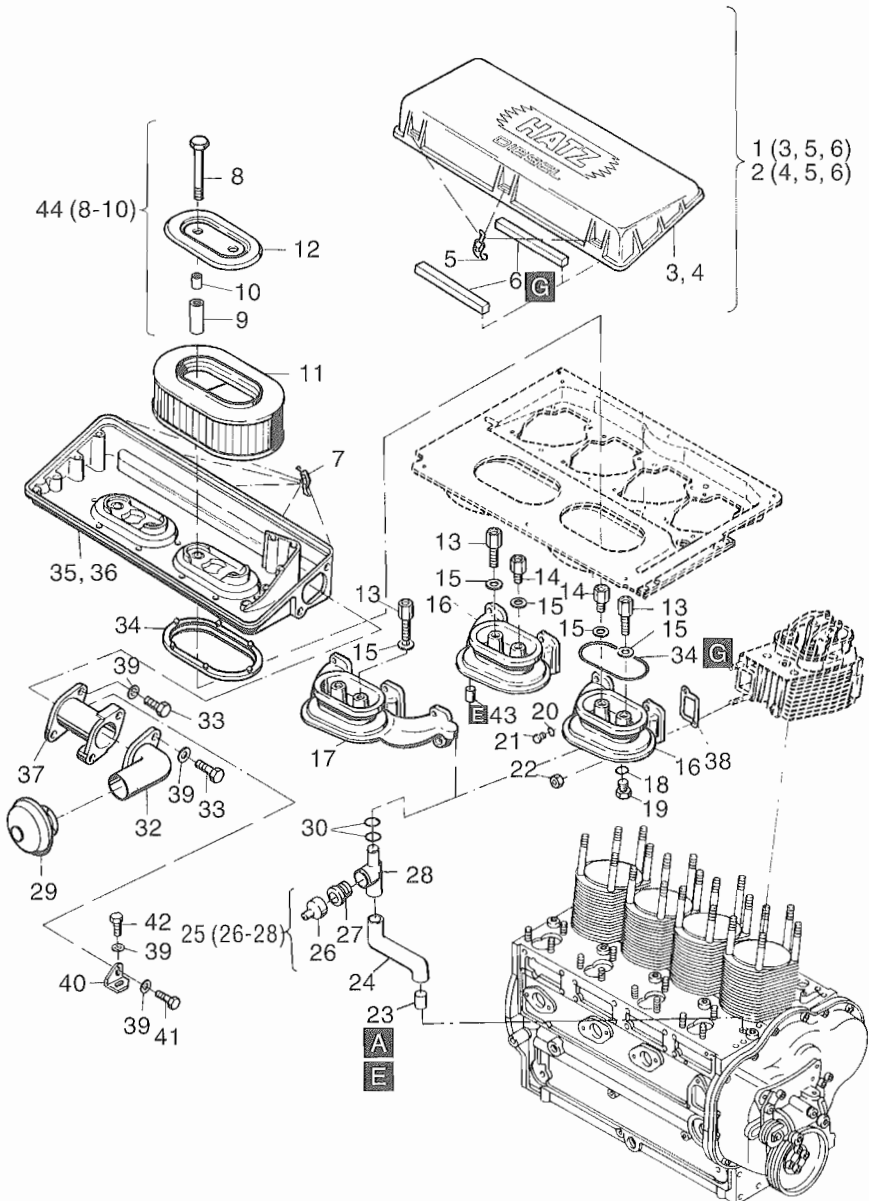

Fig.- No.	HATZ Ident-No.	Stück Qty.			P / W d / D	Bemerkungen Notes
		2 M . .	3 M . .	4 M . .		
37	01211500	-	1	-		
38	03624402	2	3	4	d1	
39	50148100	2	6	2		8,4      DIN 125-St A3C
40	03775700	-	1	-		
41	50098500	-	1	-		M 8 x 16    DIN 933-8.8 A3C
42	50135400	-	1	-		M 8 x 20    DIN 933-8.8 A3C
43	03756700	-	-	1		11,8
44	01493900	2	2	4		

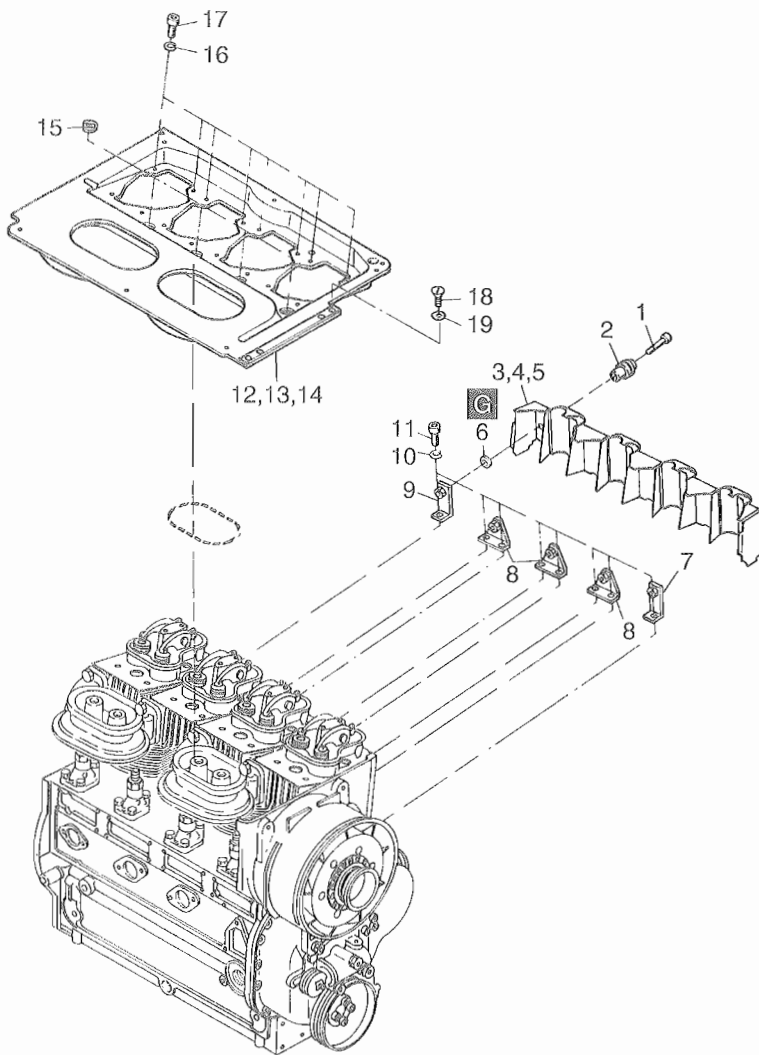

Fig.- No.	HATZ Ident-No.	Stück Qty.			P / W d / D	Bemerkungen Notes
		2 M . .	3 M . .	4 M . .		
1	50051000	3	4	5		M 6 x 30    DIN 912-8.8
2	00932700	3	4	5		
3	00938000	1	-	-		
4	00938100	-	1	-		
5	00938200	-	-	1		
6	03575500	3	4	5		
7	00923500	1	1	1		
8	00923300	1	2	3		
9	00923400	1	1	1		
10	50002800	4	6	8		8            DIN 128
11	50051600	4	6	8		M 8 x 16    DIN 912-8.8
12	01211700	1	-	-		
13	01211800	-	1	-		
14	01211900	-	-	1		
15	03592700	2	3	4	P2	
16	50081200	4	6	8	P4	A 6            DIN 137
17	50050700	4	6	8	P4	M 6 x 16    DIN 912-8.8
18	50205200	4	3	4	P4	M 8 x 16    DIN 965-8.8
19	50205100	4	3	4	P4	V 8,4        DIN 6797



Luffführung  
Air ducting  
Carter ventilation  
Conducción de aire  
Carter ventilatore

**M 26**

Tafel Nr.  
Tabl. No.  
Tavola N.

**19**

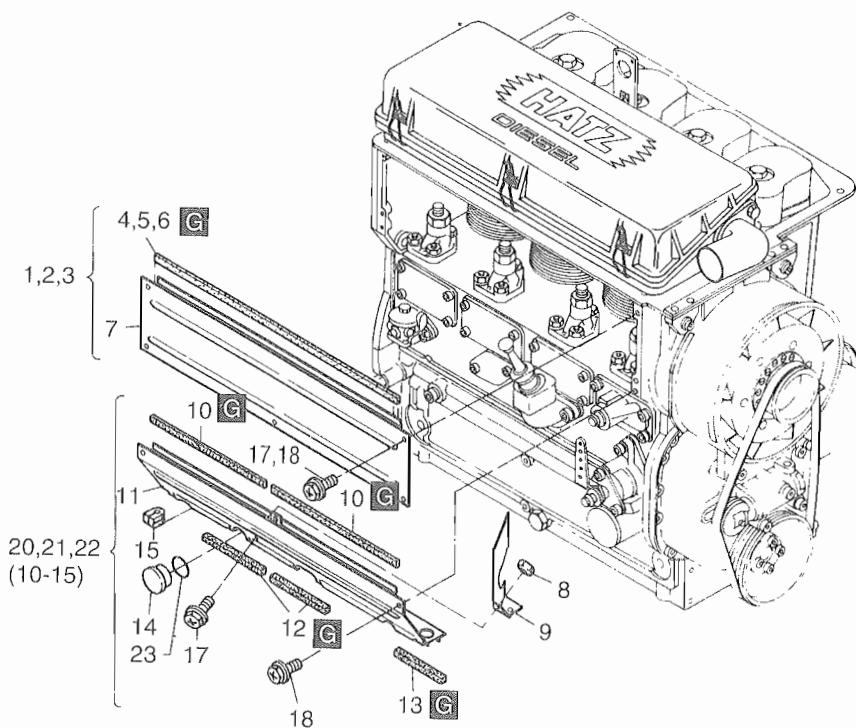

Fig.- No.	HATZ Ident-No.	Stück Qty.	P / W d / D	Bemerkungen Notes	
		2 M . .	3 M . .	4 M . .	
1	00742701	1	-	-	
2	00742601	-	1	-	
3	00745102	-	-	1	
4	03564000	1	-	-	231 mm
5	03563100	-	1	-	366 mm
6	03570000	-	-	1	501 mm
7	-----	-	-	-	
8	50144400	-	-	3	M 6          DIN 934-8 A3C
9	03601800	-	-	1	
10	03564000	1	-	-	231 mm
10	03563600	-	2	-	173 mm
10	03572600	-	-	2	240 mm
11	-----	-	-	-	
12	03598700	1	-	-	8 x 8 x 47 mm
12	03565100	-	1	2	8 x 8 x 110 mm
13	03598700	-	1	1	8 x 8 x 47 mm
14	50355300	2	3	-	F 311
14	40091400	-	-	4	F 24
15	03568900	3	3	3	
16	-----	-	-	-	
17	50341000	-	-	3	M 6 x 13
18	50341000	6	8	8	M 6 x 13
19	-----	-	-	-	
20	01181500	1	-	-	} s.Taf./Tabl. 32, Pos. 8-10
21	01181600	-	1	-	
22	01181700	-	-	1	
23	50129900	2	3	-	32 x 2,5

**M 26**  
 Luftführung  
 Air ducting  
 Carter ventilation  
 Conducción de aire  
 Carter ventilatore

Tafel Nr.  
 Tabl. No.  
 Tavola N.

**20**

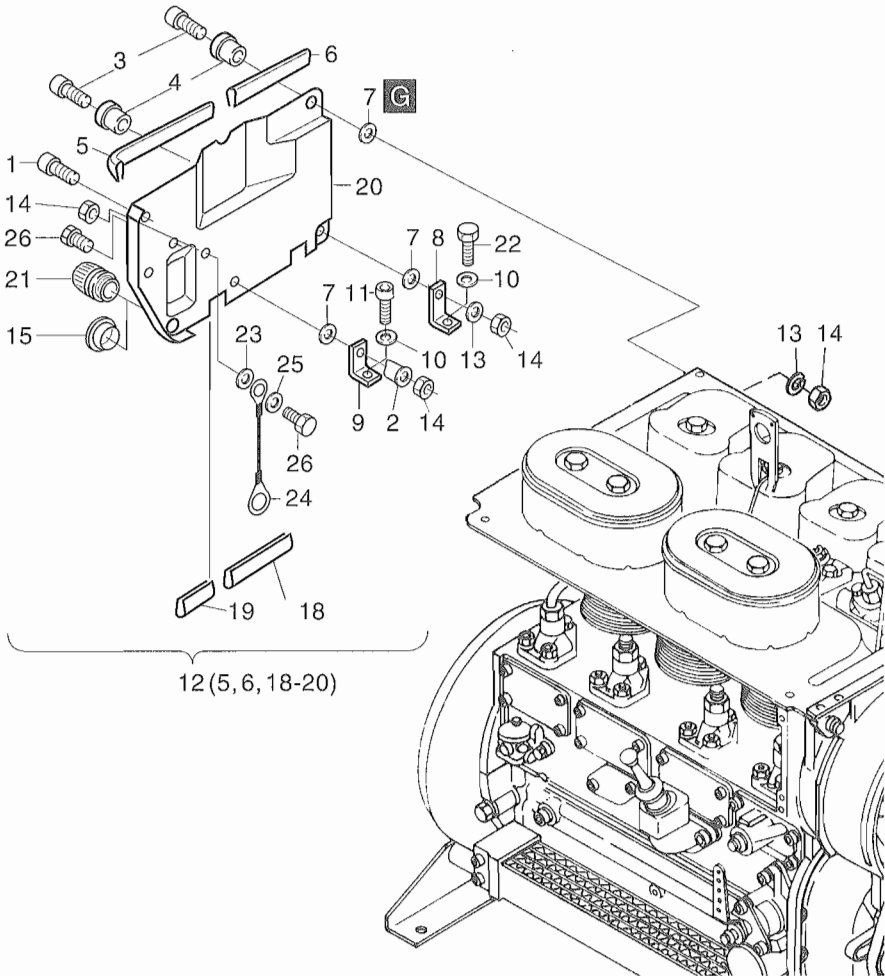

Fig.- No.	HATZ Ident-No.	Stück Qty.	P / W d / D	Bemerkungen Notes
		2..4M...		
1	50170800	2		M 6 x 25 DIN 912-8.8 A3C
2	00932700	2		
3	50170800	2		M 6 x 25 DIN 912-8.8 A3C
4	00921400	2		
5	04068900	1		220 mm
6	04069000	1		143 mm
7	03575500	4		
8	03646800	1		
9	03646900	1		
10	50002800	2		8 DIN 128
11	50051600	1		M 8 x 16 DIN 912-8.8
12	01301500	1		
13	50081200	4		A 6 DIN 137
14	50144400	4		M 6 DIN 934-8 A3C
15	40033300	0...1		F 21
16	-----	-		
17	-----	-		
18	04069200	1		113 mm
19	04069100	1		65 mm
20	-----	-		
21	50159011	0...1		
22	50026700	1		M 8 x 16 DIN 933-8.8
23	50380500	1		6,4 DIN 6797 A3C
24	-----	-		
25	50081200	1		A 6 DIN 137 A3C
26	50025400	2		M 6 x 10 DIN 933-8.8 A3C

Förderpumpe  
 Fuel feed pump  
 Pompe alimentation  
 Bomba alimentacion  
 Pompa A.C.

A 01

Tafel Nr.  
 Tabl. No.  
 Tavola N.

21

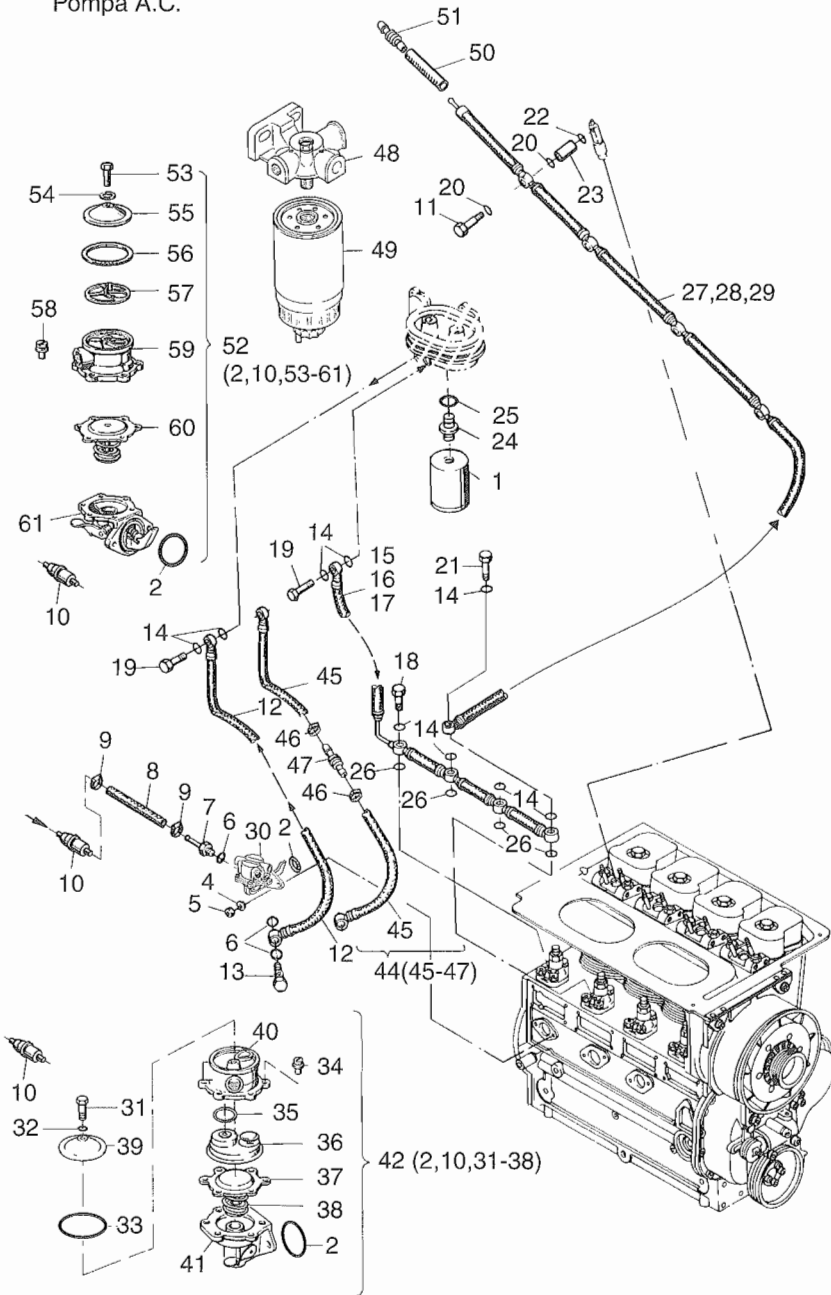

Fig.- No.	HATZ Ident-No.	Stück Qty.			P / W d / D	Bemerkungen Notes
		2 M . .	3 M . .	4 M . .		
1	50251500	1	1	1	W1	
2	50129900	1	1	1	D1	32 x 2,5
3	-----	-	-	-		
4	50081200	2	2	2		A 6           DIN 137
5	50144400	2	2	2		M 6           DIN 934-8 A3C
6	50001200	3	3	3	D4	A 14 x 18   DIN 7603-Cu
7	03466800	1	1	1		
8	03801200	1	1	1		
9	40037300	2	2	2		
10	50317000	1	1	1	W1	FILTER
11	03460200	2	3	4		
12	03573301	1	1	1		
13	50006400	1	1	1		10-3           DIN 7643
14	50001100	7	8	9	D13	A 12 x 15,5   DIN 7603-Cu
15	03836500	1	-	-		
16	03836600	-	1	-		
17	03836700	-	-	1		
18	03613400	1	2	3		
18	04108700	1	2	3		.M41
19	50006300	2	2	2		8-13           DIN 7643
20	50000900	4	6	8	d1,D8	A 8 x 11,5   DIN 7603-Cu
21	03639700	1	1	-		
21	04108800	1	1	-		.M41
21	03890600	-	-	1		
22	50000800	2	3	4	d1	A 6,5 x 9,5   DIN 7603-Cu
23	03573900	2	3	4		
24	50253300	1	1	1		A LL 10       DIN 7647
25	50001200	1	1	1		A 14 x 18   DIN 7603-Cu
26	03969400	2	3	4		
27	00806300	1	-	-		
28	00806100	-	1	-		
29	00806000	-	-	1		
30	01478902	1	1	1		Förderpumpe, fuel pump, FCM-IMSA
31	-----	-	-	-		
32	-----	-	-	-		
33	50399500	1	1	1		37 x 2,5
34	-----	-	-	-		

A 01

Förderpumpe  
Fuel feed pump  
Pompe alimentation  
Bomba alimentacion  
Pompa A.C.

Tafel Nr.  
Tabl. No.  
Tavola N.

21

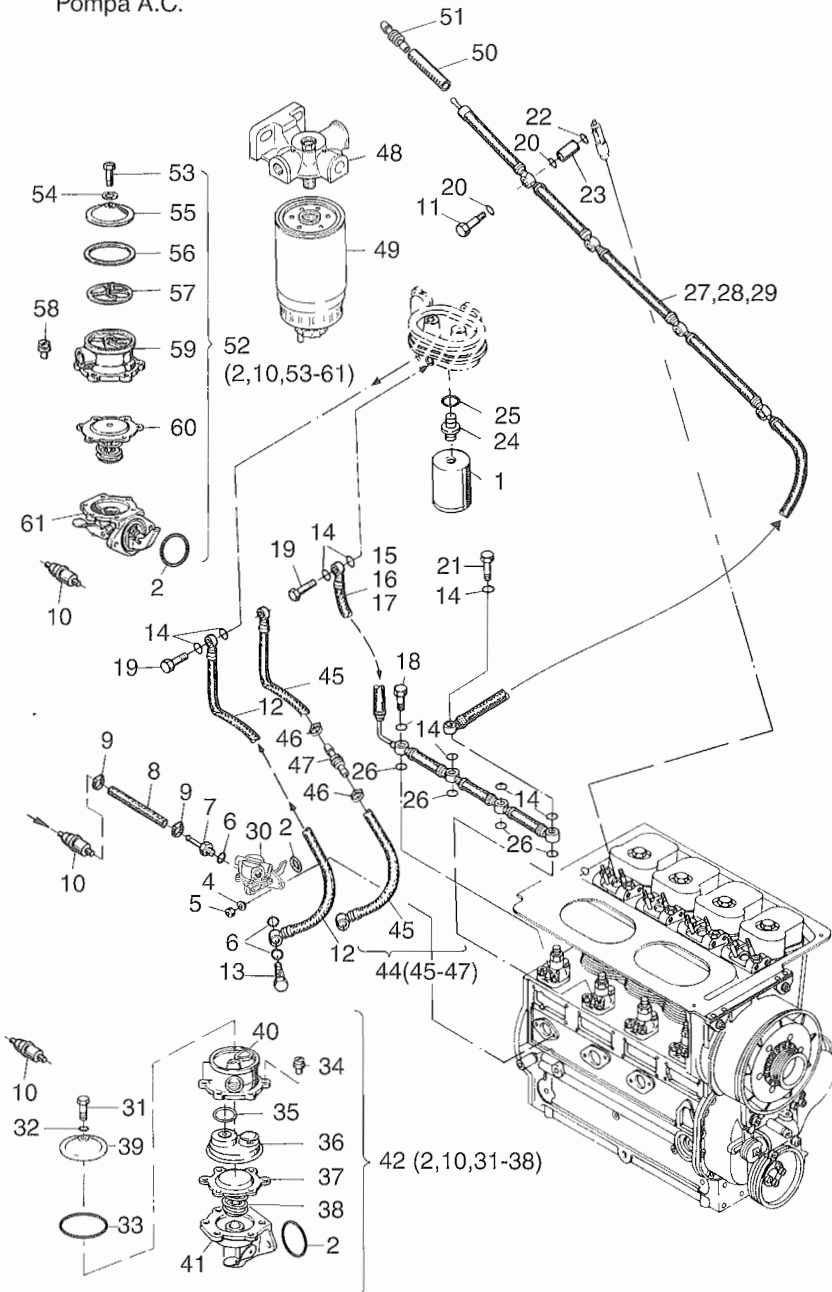

Fig.- No.	HATZ Ident-No.	Stück Qty.			P / W d / D	Bemerkungen Notes
		2 M ..	3 M ..	4 M ..		
35	-----	-	-	-		
36	-----	-	-	-		
37	-----	-	-	-		
38	-----	-	-	-		
39	-----	-	-	-		
40	-----	-	-	-		
41	-----	-	-	-		
42	01479001	1	1	1		Reparatursatz, repair kit FCM-IMSA
43	-----	-	-	-		
44	01191100	1	1	1		nicht bei Taf. 27-Pos. 1
45	-----	-	-	-		not for Tabl. 27-Pos. 1
46	40037300	2	2	2		
47	50343400	1	1	1		
48	50345600	1	1	1		
49	50345700	1	1	1		
50	03663700	1	1	1		} f. Taf. 27-Pos. 1 } for Tabl. 27-Pos. 1
51	50254200	1	1	1		
52	01562700	1	1	1		AP Pierburg
53	-----	-	-	-		
54	49018500	1	1	1		10 x 5 x 1 Pierburg
55	-----	-	-	-		
56	49018400	1	1	1		44 x 38 x 0,75
57	49018300	1	1	1		Pierburg (Filter)
58	49018100	6	6	6		Pierburg
59	-----	-	-	-		
60	49018200	1	1	1		Pierburg
61	-----	-	-	-		



**A01**

Kraftstoffbehälter  
Fuel tank  
Reservoir à carburant  
Depósito combustible  
Serbatoio combustibile

Tafel Nr.  
Tabl. No.  
Tavola N.

**22**

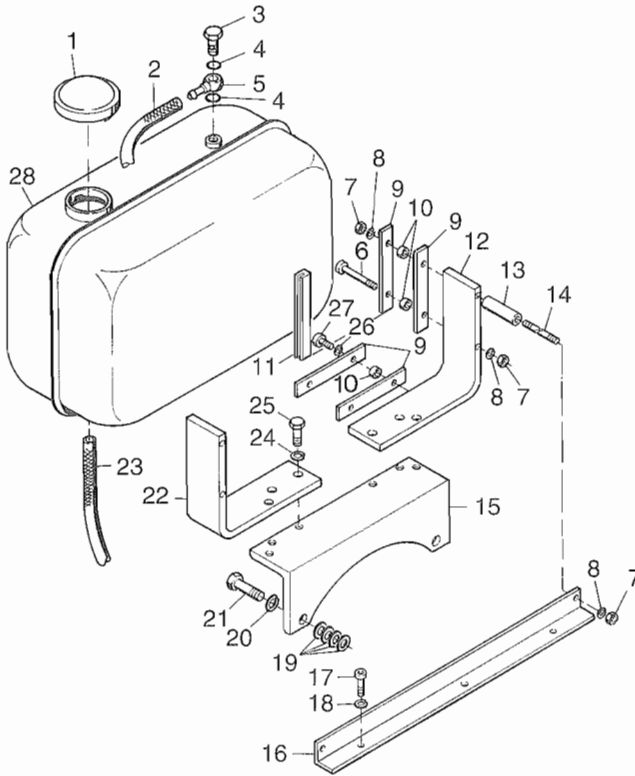

Fig.- No.	HATZ Ident-No.	Stück Qty.	P / W d / D	Bemerkungen Notes
		2..4M..		
1	40032701	1		
2	03881600	1		4,5 x 200
3	50006100	1		4-5-3 DIN 7643
4	50000900	2		A 8 x 11,5 DIN 7603-Cu
5	50015700	1		
6	50120900	2		M 8 x 85 DIN 912-8.8 A3C
7	50148000	9		M 8 DIN 934-8 A3C
8	50208500	6		8 DIN 128-A3C
9	03887000	8		
10	03971000	8		8,4 x 12 x 7
11	03887100	4		
12	03886500	1		
13	03915900	2		9 x 13 x 42,6
14	50129400	2		M 8 x 140 DIN 835-8.8 A3C
15	03886400	1		
16	03886900	1		
17	50206300	3		M 8 x 18 DIN 912-8.8 A3C
18	50208500	3		8 DIN 128 A3C
19	50017400	8		15 DIN 433 St
20	50259900	2		14 DIN 128-A3C
21	50176900	2		M 14x1,5x65 DIN 960-8.8 A3C
22	03886600	1		
23	03493500	1		7 x 200
24	50135600	6		10 DIN 128-A3C
25	50136400	6		M 10x25 DIN DIN 933-8.8 A3C
26	50208500	4		8 DIN 128-A3C
27	50175900	4		M 8 x 30 DIN 912-8.8 A3C
28	01099200	1		

**A 02**

Zyklon  
Cyclon  
Cyclone  
Ciclone  
Prefiltro a ciclone

Tafel Nr.  
Tabl. No.  
Tavola N.

**23**

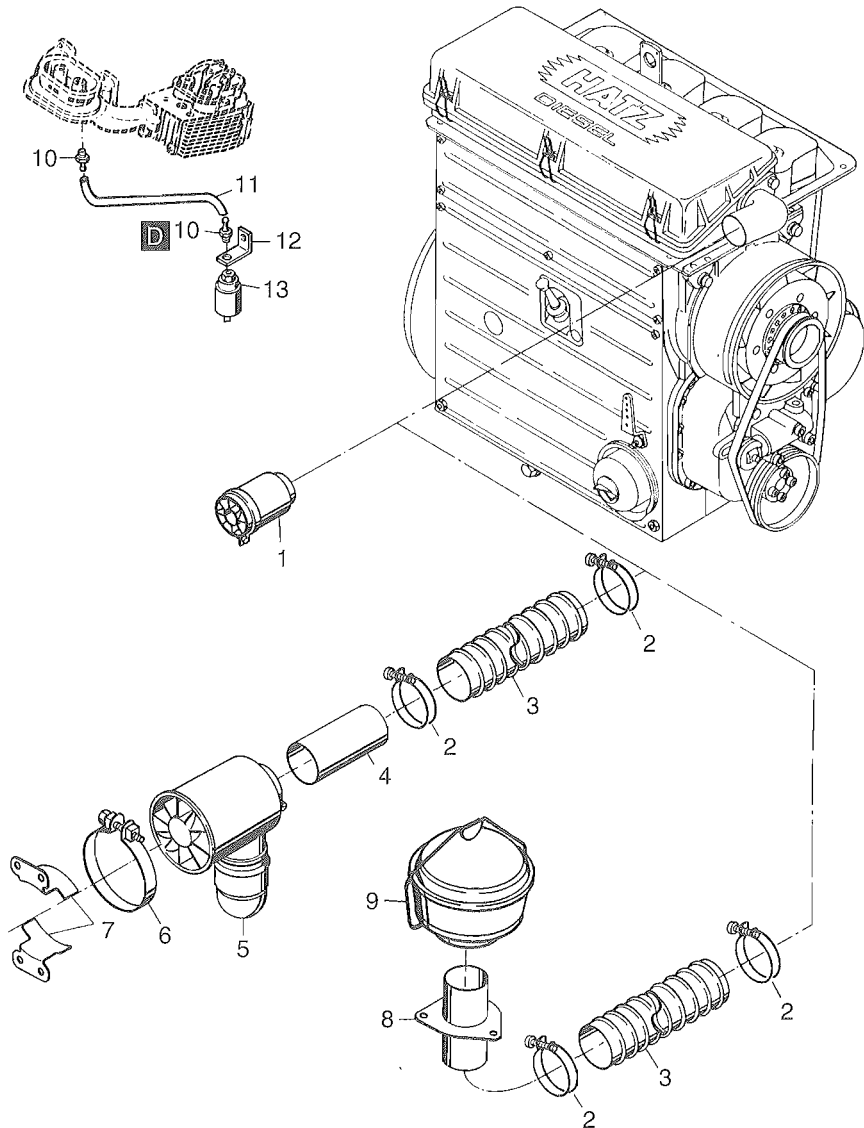

Fig.- No.	HATZ Ident-No.	Stück Qty.	P / W d / D	Bemerkungen Notes
		2..4M..		
1	01216000	1		
2	50197300	2		64/73
3	03905300	1...4		1 m
4	03820500	1		
5	40035300	1		
6	40029100	1		
7	03820800	2		
8	01027100	1		
9	50196100	1		
10	50167700	2		
11	03481100	1		4,5 x 520
12	03693610	1		
13	50346300	1		

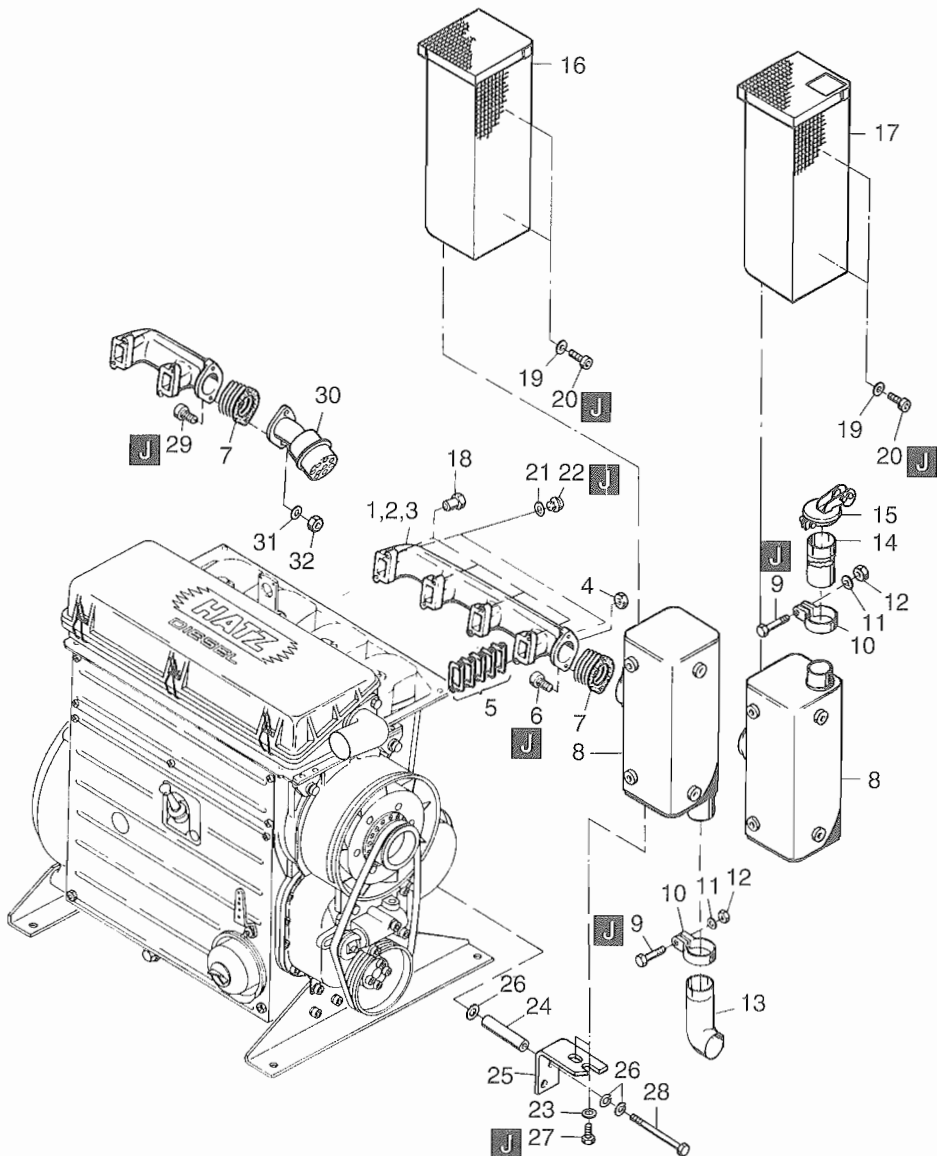

Fig.- No.	HATZ Ident-No.	Stück Qty.			P / W d / D	Bemerkungen Notes	
		2 M ..	3 M ..	4 M ..			
1	03625100	1	-	-			
2	03631900	-	1	-			
3	03632000	-	-	1			
4	50400700	2	3	4	P2	M 8	DIN 934-8 C4P
5	01284501	2	3	4	d1		
6	50225000	2	2	2		M 10 x 30	DIN 912-10.9 C4P
7	50165901	5	5	5			
8	01109101	1	1	1			
9	50249500	1	1	1		M 10 x 50	DIN 931-8.8 A3C
10	03877800	1	1	1			
11	50145900	1	1	1		10,5	DIN 125-St A3C
12	40028600	1	1	1		M 10	SSN 440-8 Cu
13	03885600	1	1	1			
14	03889600	1	1	1			
15	50156900	1	1	1			
16	01091400	1	1	1			
17	03885800	1	1	1			
18	03625200	2	3	4	P2		
19	50120000	6	6	6		A 6,4	DIN 9021-St A3C
20	50139000	6	6	6		M 6 x 10	DIN 912-8.8 C4P
21	03228800	2	3	4			
22	50044700	2	3	4		R 1/4	DIN 910
23	50123000	2	2	2		8,4	DIN 7349
24	03538701	2	2	2		9 x 14 x 42	
25	03922900	1	1	1			
26	50148100	6	6	6		8,4	DIN 125-St A3C
27	50357400	2	2	2		M 8 x 25	DIN 933-8.8 C4P
28	50087900	2	2	2		M 8 x 70	DIN 931-8.8
29	50032600	2	-	-		M 10 x 40	DIN 933-8.8 C4P
30	00872300	1	-	-		n ≤ 2300min <sup>-1</sup>	
31	50135600	2	-	-		10	DIN 128 A3C
32	40028600	2	-	-		M 10	SSN 440-8 Cu

Andrehkurbel, Ändrehvorrichtung  
 Starting handle, starting device  
**A04** Manivelle, dispositif demarrage  
 Manivela, dispositivo de arranque  
 Manovella, dispositivo di avviamento

Tafel Nr.  
 Tabl. No.  
 Tavola N.

25

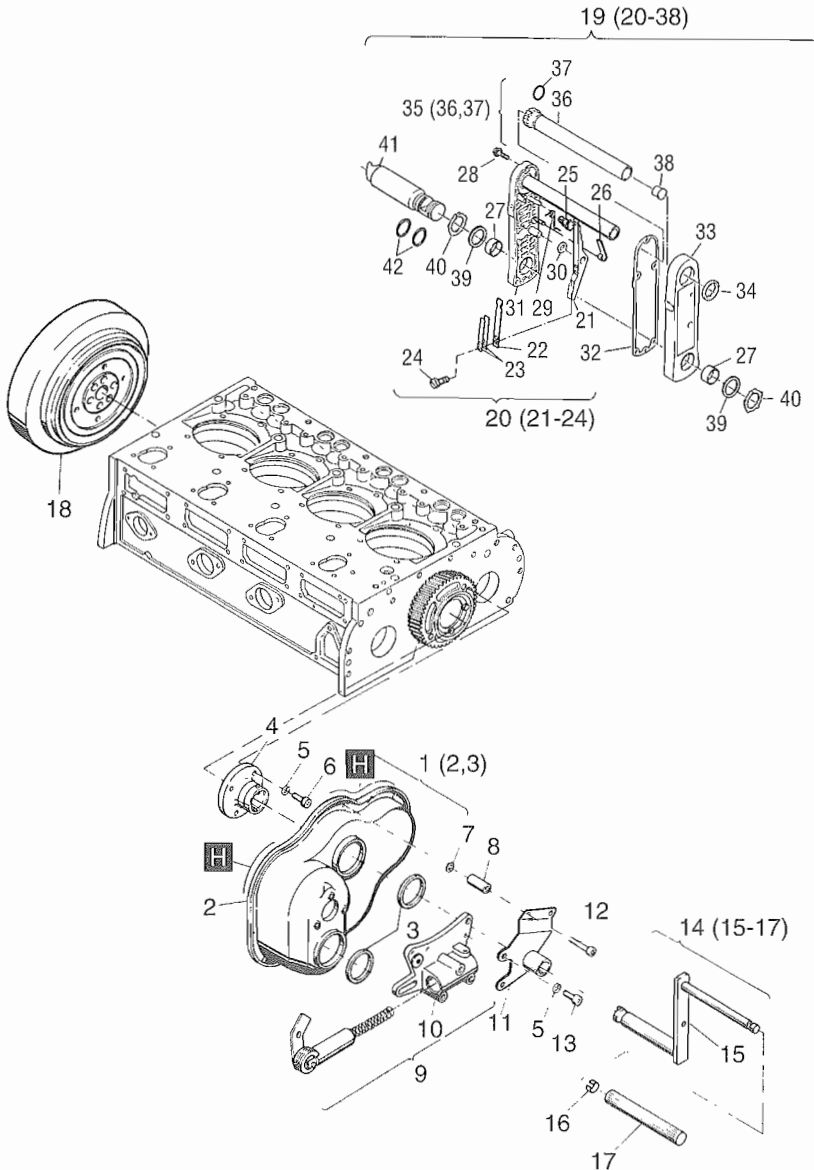

Fig.- No.	HATZ Ident-No.	Stück Qty.	P / W d / D	Bemerkungen Notes
		2..4M..		
1	00995400	1		
2	-----	-		
3	50129100	2		55 x 70 x 8
4	00991600	1		
5	50002800	6	8	DIN 128
6	50052000	4	M 8 x 20	DIN 6912-8.8
7	50148100	2	8,4	DIN 125 St A3C
8	03538701	2		
9	00995502	1		
10	-----	-		
11	00995100	1		
12	50081800	2	M 8 x 65	DIN 912-8.8
13	50052000	2	M 8 x 20	DIN 6912-8.8
14	00995000	1		
15	-----	-		
16	03515400	1		
17	03522400	1		
18	03846900	1		
19	01027805	1		„A“
20	01011404	1		
21	-----	-		
22	03812102	1		
23	03917100	2		
24	50316500	2	M 5 x 8	DIN 6912-8.8
25	03955600	1		
26	03954900	1		
27	50193400	2		
28	50194400	5	M 6 x 25	WN 11084-8.8 Zn
29	03955900	1		„A“
30	50195800	1	10 x 16 x 0,5	DIN 988
31	-----	-		
32	03813000	1		



**A04** Andrehkurbel, Andrehvorrichtung  
 Starting handle, starting device  
 Manivelle, dispositif demarrage  
 Manivela, dispositivo de arranque  
 Manovella, dispositivo di avviamento

Tafel Nr.  
 Tabl. No.  
 Tavola N.  
**25**

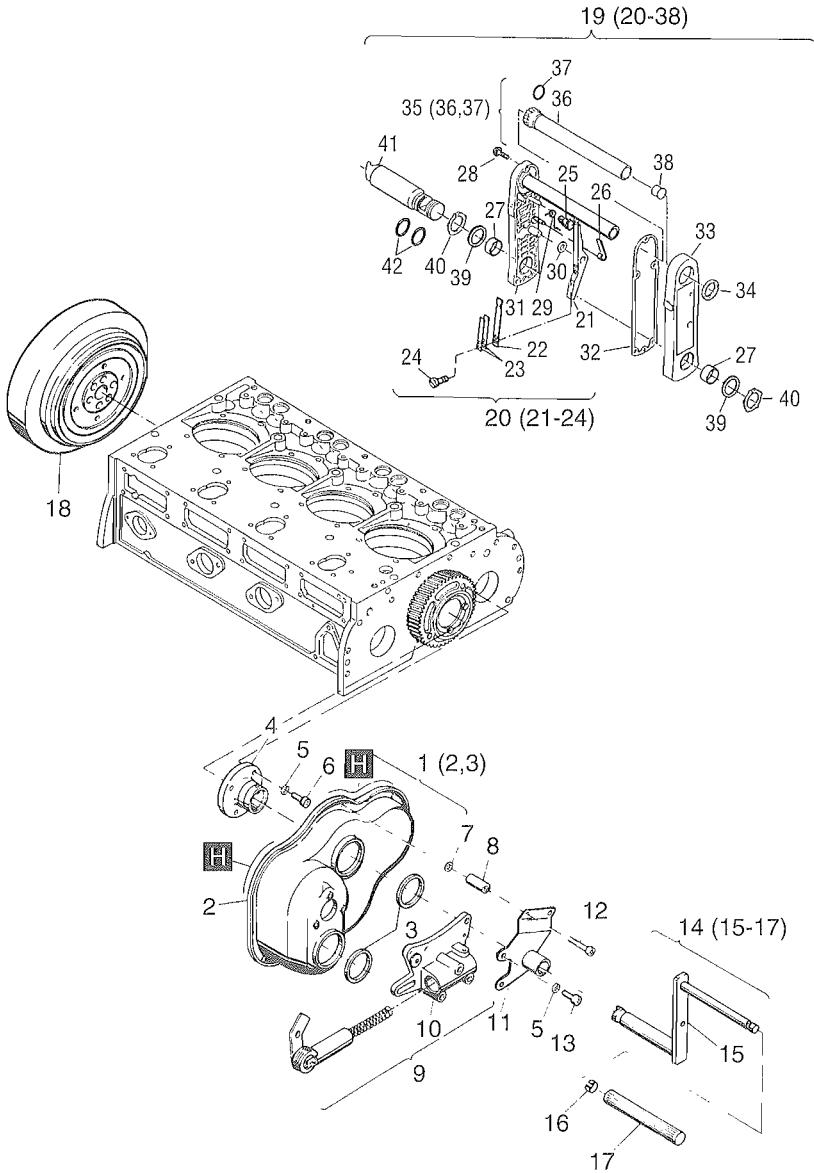

Fig.- No.	HATZ Ident-No.	Stück Qty.	P / W d / D	Bemerkungen Notes
		2..4M..		
33	-----	-		
34	50194200	1		28 x 35 x 4
35	01011310	1		
36	-----	-		
37	50169100	1		19 x 1,8    DIN 769
38	50199200	1		V 18
39	03928600	2		30 x 38 x 0,15
40	50194300	2		A 30 x 1,5 K DIN 983
41	01039900	1		192 mm
42	50258500	2		26 x 1,5

**A04**

Dekompressionsautomatik  
Autom. decompression  
Décompression autom.  
Decompression autom.  
Decompressione automatica

Tafel Nr.  
Tabl. No.  
Tavola N.

**26**

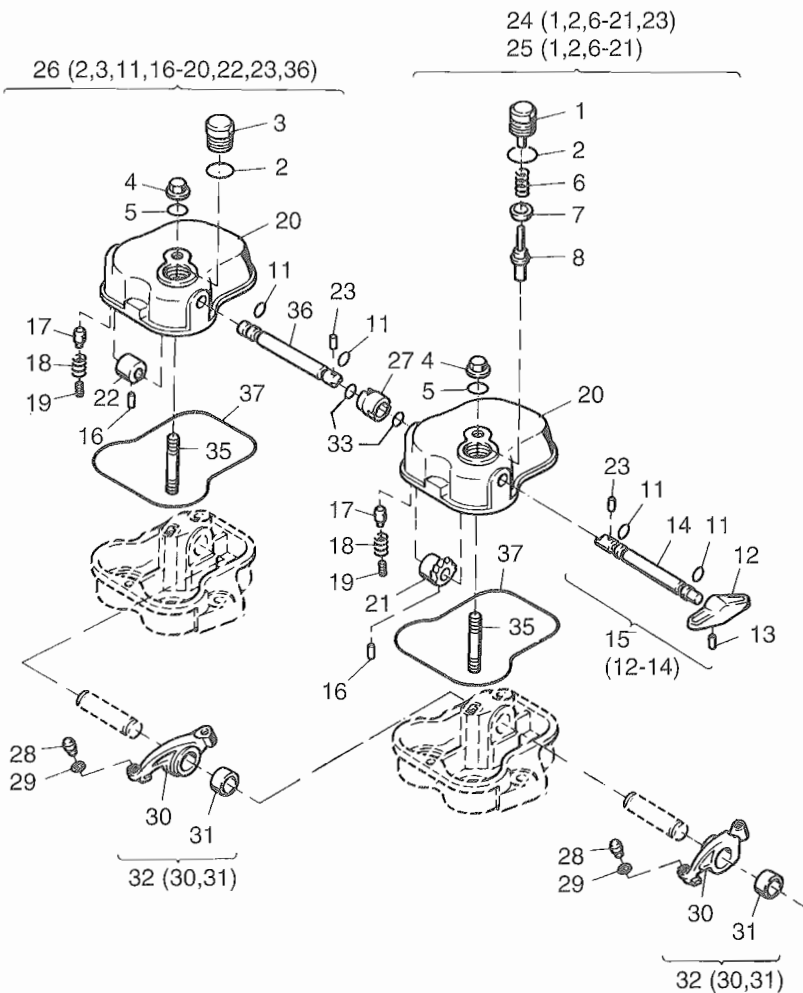

Fig.- No.	HATZ Ident-No.	Stück Qty.			P / W d / D	Bemerkungen Notes
		2 M . .	3 M . .	4 M . .		
1	00994600	1	3	4		
2	50001600	2	3	4	D4	A 22 x 27 DIN 7603-Cu
3	03765600	1	-	-		
4	50248400	2	3	4		M 10-6 DIN 986
5	50248500	2	3	4		
6	03188700	1	3	4		
7	03772100	1	3	4		
8	03762901	1	3	4		
11	40022300	4	6	8		
12	03778200	1	3	4		
13	50034600	1	3	4		4 x 18 DIN 1481
14	-----	-	-	-		
15	01206500	1	-	-		
15	01214600	-	3	4		
16	50034100	2	3	4		3 x 16 DIN 1481
17	03760100	2	3	4		
18	03759700	2	3	4		
19	50065000	2	3	4		AM 10 x 10 TUF-LOK DIN 913
20	03759310	2	3	4		
21	03759911	1	3	4		
22	03760310	1	-	-		
23	50248600	2	-	-		4 x 20 DIN 7343
24	00988010	1	-	-		
25	01214500	-	3	4		
26	00988110	1	-	-		
27	03760700	1	-	-		
28	03451900	2	3	4		
29	50123200	0..8	0..12	0..16		5 x 10 x 0,5 DIN 988
30	-----	-	-	-		
31	03184100	2	3	4		
32	00532602	2	3	4		
33	50257300	2	-	-		12 x 2,5
34	-----	-	-	-		
35	50248200	2	3	4		M 10 x 60 DIN 939-8.8
36	03760210	1	-	-		
37	50254400	2	3	4		120,32 x 2,62

Abschaltautomatik mech.  
Autom. shut-off device  
Arret. autom. moteur  
Parada autom. motor  
Arresto automatico motore

**A04**

Tafel Nr.  
Tabl. No.  
Tavola N.

**27**

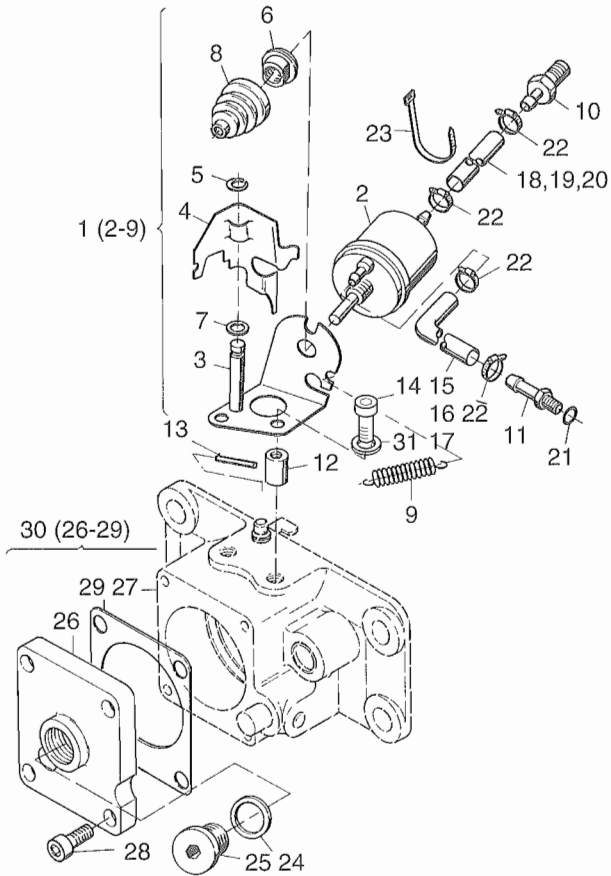

Fig.- No.	HATZ Ident-No.	Stück Qty.			P / W d / D	Bemerkungen Notes
		2 M ..	3 M ..	4 M ..		
1	01123200	1	1	1		
2	01105900	1	1	1		
3	01106000	1	1	1		
4	03898500	1	1	1		
5	50117200	1	1	1	4	DIN 6799
6	03922000	1	1	1		
7	50144500	1	1	1	6,4	DIN 125-St A3C
8	50180400	1	1	1		
9	50286000	1	1	1		
10	01106100	1	1	1		
11	03897800	1	1	1		
12	04098400	2	2	2	7 x 14 x 16,3	
13	50034300	1	1	1	3 x 36	DIN 1481
14	50323900	2	2	2	M 6 x 30	DIN 912-8.8 A3C
15	03899200	1	-	-	270 mm	
16	03902000	-	1	-	390 mm	
17	03902100	-	-	1	540 mm	
18	03899300	1	-	-	400 mm	
19	03902100	-	1	-	540 mm	
20	03902200	-	-	1	640 mm	
21	50316700	1	1	1		
22	40093400	4	4	4		
23	50358400	1	2	3		
24	50001200	1	1	1	14 x 18	DIN 7603-Cu
25	50143500	1	1	1	M 14 x 1,5	DIN 908
26	03934801	1	1	1		
27	-----	-	-	-	s. Taf., Tab. 13-	Pos. 1...
28	50170700	4	4	4	M6 x 16	DIN 912-8.8 A3C
29	03934400	1	1	1		
30	01593300	1	1	1		
31	50170900	1	1	1	6	DIN 128-A3C

Starter, Generator  
 Starter, alternator  
**A05** Demarreur, alternateur  
 Arrancador, alternador  
 Motorino avviamento, alternatore

Tafel Nr.  
 Tabl. No.  
 Tavola N.

28

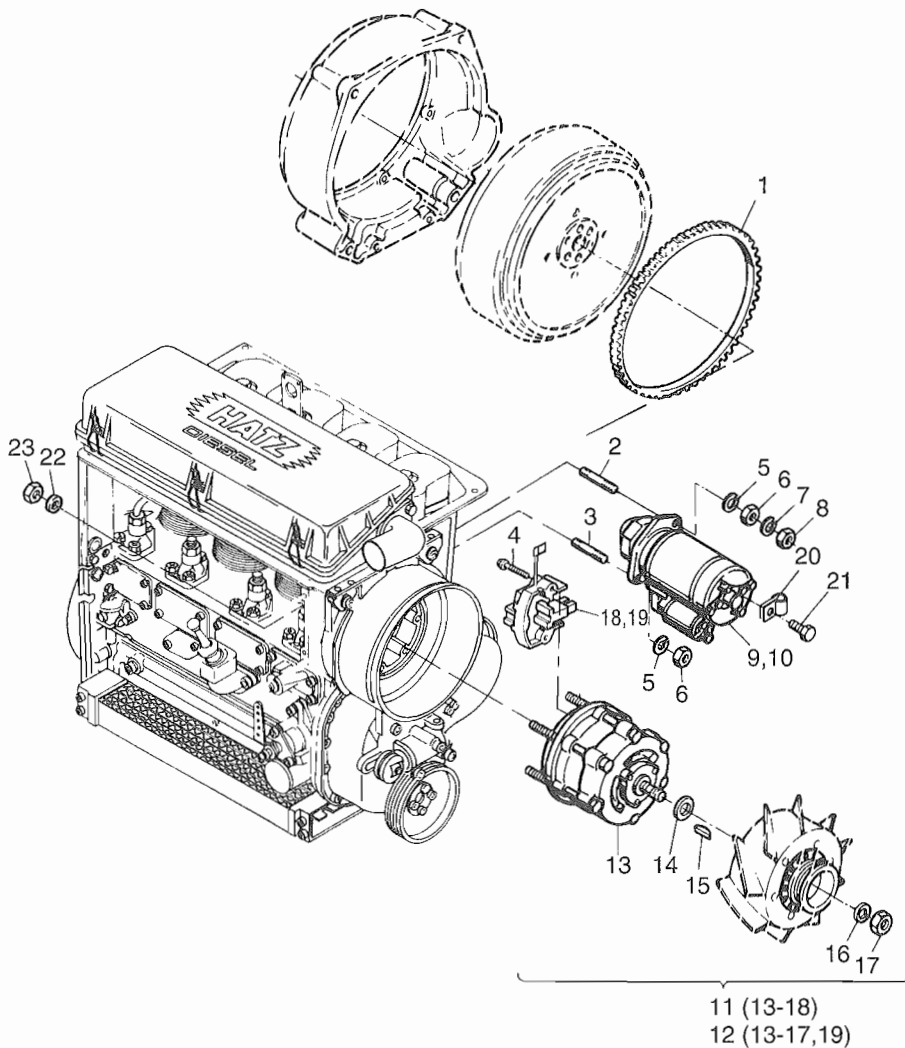

Fig.- No.	HATZ Ident-No.	Stück Qty.	P / W d / D	Bemerkungen Notes
		2..4M..		
1	03156101	1		
2	03286800	1		
3	50042300	1		M 12 x 25 DIN 938-5.6
4	-----	-		
5	50003000	2	12	DIN 128
6	50023900	2	M 12	DIN 934-8
7	50063200	1	12	DIN 128 A3C
8	50063500	1	M 12	DIN 936-17 H
9	50183500	1	12 V	2,7 KW
10	50195400	1	24 V	4,0 KW
11	40121002	1	14 V	50 A
12	50164902	1	28 V	40 A
13	-----	-		
14	-----	-		
15	50017800	1	4 x 6,5	DIN 6888
16	-----	-		
17	49053600	1		
18	49053802	1	14 V	
19	49053902	1	28 V	
20	50158400	1		
21	50165500	1	M 6 x 12	DIN 933-8.8 A3C
22	50081200	5	A 6	DIN 137 A3C
23	50144400	5	M 6	DIN 934-8 A3C



# A 05

Armaturenkasten  
Instrument box  
Boîtier de bord  
Cuadro de mando  
Cruscotto

Tafel Nr.  
Tabl. No.  
Tavola N.

29

1 (3-18,20,23-26,28-41,43,45,46)

2 (3-18,20,23-25,27-40,42,44-46)

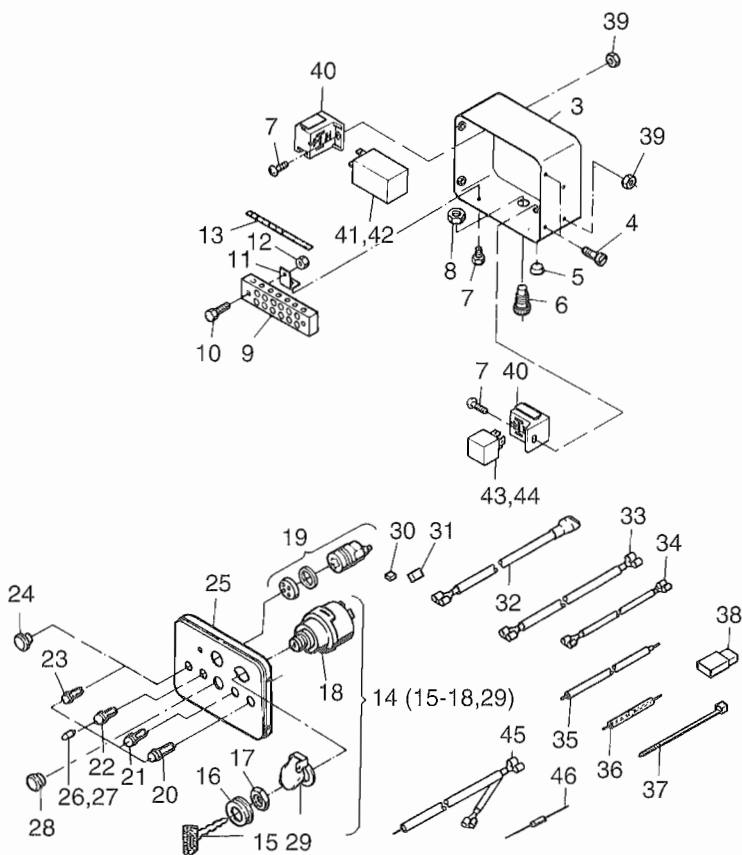

Fig.- No.	HATZ Ident-No.	Stück Qty.			P / W d / D	Bemerkungen Notes
		2 M . .	3 M . .	4 M . .		
1	00826204	1	1	1		12 V
2	00823604	1	1	1		24 V
3	00716311	1	1	1		
4	50289200	4	4	4		M 6 x 12 SB-8.8 A3C
5	50160800	2	2	2		
6	50159011	1	1	1		
7	50049300	4	4	4		M 5 x 10 DIN 7985-4.8 A3R
8	50159100	1	1	1		
9	50160700	1	1	1		
10	50158800	2	2	2		M 4 x 20 DIN 84-4.8 A3C
11	03666700	2	2	2		
12	50147100	2	2	2		M 4 DIN 934-8 A3C
13	03671701	1	1	1		
14	50276502	1	1	1		
15	50345300	1	1	1		
16	-----	-	-	-		
17	-----	-	-	-		
18	-----	-	-	-		
19	40068600	1	1	0...2		4 M...: 12 V (2) 24 V (1)
20	50176500	1	1	1		BATT
21	50176600	1	1	1		OIL
22	50176400	1	1	1		TEMP
23	50182400	1	1	1		FILTER
24	40096000	0...2	0...2	0...2		F 17
25	03509211	1	1	1		
26	40009700	4	4	4		12 V 2 W
27	40009800	4	4	4		24 V 2 W
28	40091400	0...2	0...2	0...2		F 24
29	49050900	1	1	1		
30	50276600	1	1	1		4-P
31	50276700	1	1	1		6-P
32	00818203	1	1	1		
33	01089801	1	1	1		
34	01089901	1	1	1		
35	01090201	1	1	1		
36	01150101	1	1	1		

**A05**

Armaturenkasten  
Instrument box  
Boitiere de bord  
Cuadro de mando  
Cruscotto

Tafel Nr.  
Tabl. No.  
Tavola N.

**29**

1 (3-18,20,23-26,28-41,43,45,46)

2 (3-18,20,23-25,27-40,42,44-46)

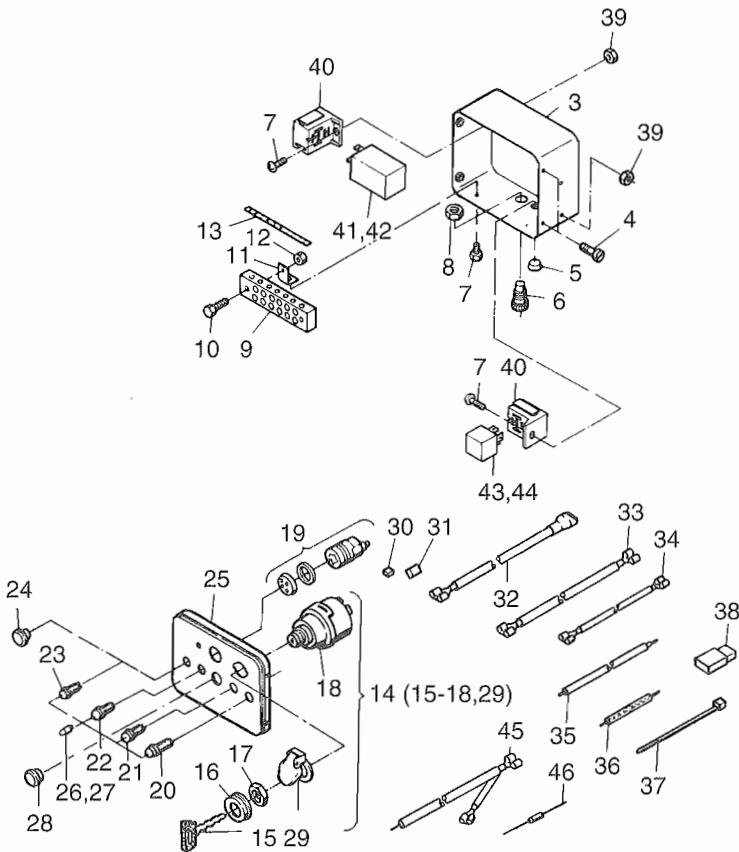

Fig.- No.	HATZ Ident-No.	Stück Qty.			P / W d / D	Bemerkungen Notes
		2 M . .	3 M . .	4 M . .		
37	50358400	3	3	3		
38	50190700	1	1	1		
39	40028200	2	2	2		
40	50276000	2	2	2		
41	50275802	1	1	1		12 V HATZ MSR
42	50275902	1	1	1		24 V HATZ MSR
43	50277701	1	1	1		12 V BOSCH
44	50277801	1	1	1		24 V BOSCH
45	01154901	1	1	1		
46	50344400	1	1	1		

**A05**

Armaturen, Leitungen  
Electric equipment, wirings  
Equipment électrique, cable  
Equipo eléctrico, cables  
Equipaggiamento elettrico, cablaggio

Tafel Nr.  
Tabl. No.  
Tavola N.

**30**

Fig.- No.	HATZ Ident-No.	Stück Qty.	P / W d / D	Bemerkungen Notes
		2 M...	3 M...	4 M...
1	01183300	1	-	-
2	01183500	-	1	-
3	01183700	-	-	1
4	50167700	2	2	2
5	50163900	1	1	1...2
6	50268600	1	1	1
7	50164100	-	-	1
8	03481100	1	1	1
9	-----	-	-	-
10	03693610	1	1	1
11	50167600	1	1	1
12	01183200	1	-	-
13	01183400	-	1	-
14	01183600	-	-	1
15	50158500	1	1	1
16	40021300	1	1	1
17	-----	-	-	-
18	50148100	1	1	1
19	50026700	1	1	1
20	-----	-	-	-
21	01541700	1	1	1
22	01541800	1	1	1
23	03668210	1	1	1
24	40088300	1	1	-
25	40026600	1	1	1
26	-----	-	-	-
27	00817100	1	1	1
28	03579800	1	1	1
29	50114300	1	1	1
30	03960200	1	1	1
31	50095100	1	1	1
32	50358600	1	1	1
33	03951800	2	3	4
34	-----	-	-	-
35	-----	-	-	-
36	50351200	1	1	1
37	50351000	3	3	3
38	50350900	3	3	3
39	50351100	1	1	1
40	50434400	4	4	4
41	50346100	1	1	1

184 G 4 M...: 12 V (2) 24 V (1)  
TEMP  
400 G 24 V

OIL  
8,4 DIN 125-St A3C  
M 8 x 16 DIN 933-8.8

12 V  
24 V  
2000 mm  
24 V

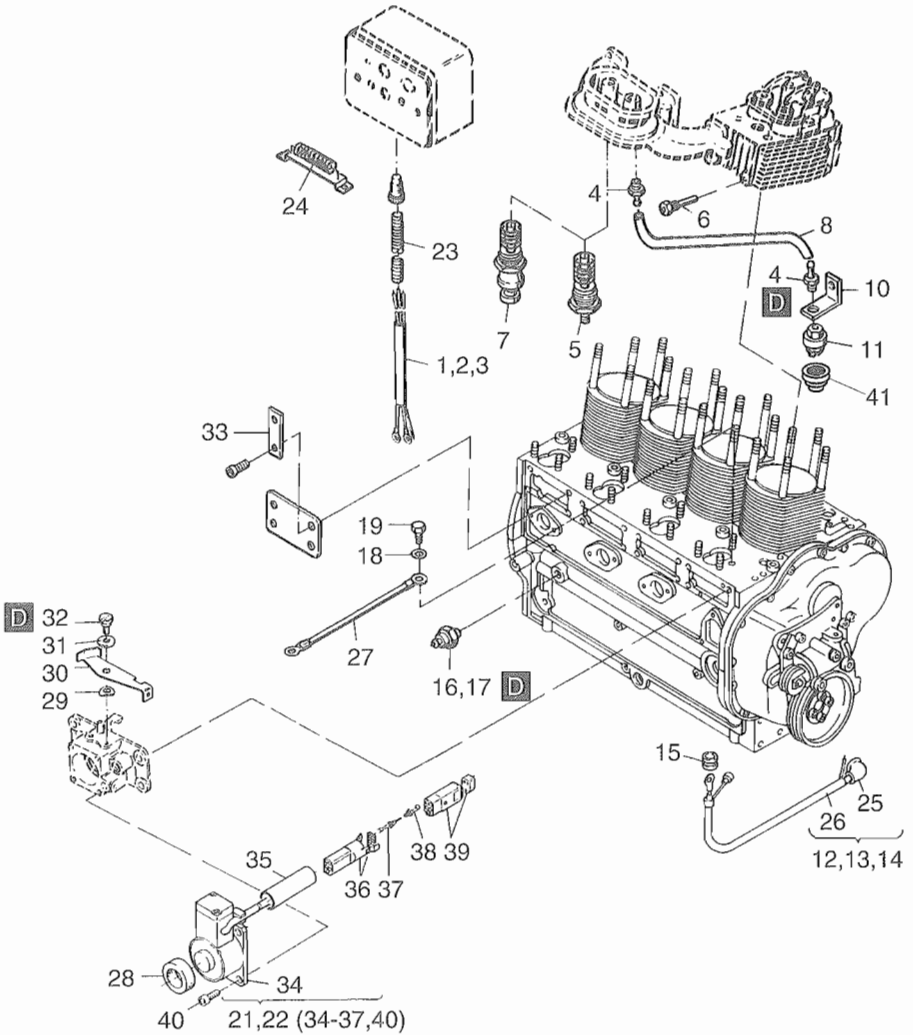
6,4 DIN 7349

A 8 DIN 137  
M 6 x 3 DIN 923-A3C

M 6 x 30 DIN 912-8.8 A3C Tuf.

A06

Motorfüße, Schwingungsdämpfer  
Engine brackets, vibration damper  
Pieds moteur, amortisseur vibrat.  
Soportes del motor, amortiguador vibrac.  
Staffe supporto motore, antivibranti

Tafel Nr.  
Tabl. No.  
Tavola N.

31

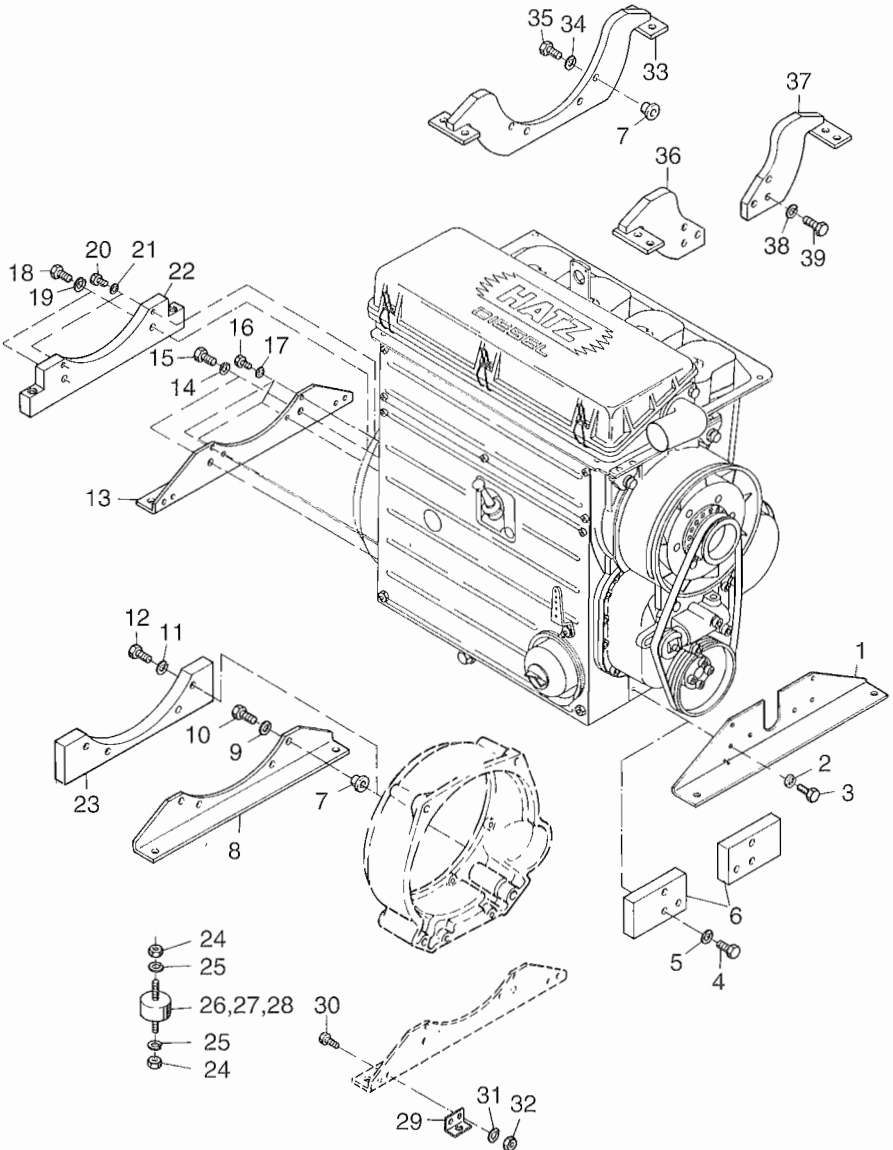

Fig.- No.	HATZ Ident-No.	Stück Qty.	P / W d / D	Bemerkungen Notes
2..4M..				
1	03878601	1		
2	50003000	6		12 DIN 128
3	50031100	6		M 12 x 28 DIN 933-8.8
4	50031600	6		M 12 x 50 DIN 931-8.8
5	50003000	6		12 DIN 128
6	03853601	2		$n \leq 2300 \text{ min}^{-1}$
7	03579100	4		
8	03878700	1		
9	50003000	4		12 DIN 128
10	50259300	4		M 12 x 110 DIN 931-8.8 A3C
11	50063200	4		12 DIN 128 A3C
12	50259300	4		M 12 x 110 DIN 931-8.8 A3C
13	03878800	1		
14	50003100	2		14 DIN 128
15	50187500	2		M 14 x 1,5 x 30 DIN 961-8.8
16	50029200	4		M 10 x 25 DIN 933-8.8
17	50002900	4		10 DIN 128
18	50275600	2		M 14 x 1,5 x 55 DIN 960-8.8
19	50259900	2		14 DIN 128 A3C
20	50029600	2		M 10 x 45 DIN 933-8.8 A3C
21	50135600	2		10 DIN 128 A3C
22	03855001	1		$n \leq 2300 \text{ min}^{-1}$
23	03854901	1		$n \leq 2300 \text{ min}^{-1}$
24	50145800	8		M 10 DIN 934-8 A3C
25	50135600	8		10 DIN 128 A3C
26	50260100	4		40 SH 7
27	50260200	4		55 SH 8
28	50260300	4		65 SH 9
29	03875400	2		
30	50029300	4		M 10 x 30 DIN 933-8.8
31	50002900	4		10 DIN 128
32	50023500	4		M 10 DIN 934-8
33	01089600	1		
34	50063200	4		12 DIN 128 A3C
35	50259300	4		12 x 110 DIN 931-8.8 A3C
36	01089400	1		
37	01089500	1		
38	50063200	6		12 DIN 128 A3C
39	50232200	6		M 12 x 40 DIN 933-8.8 A3C



Ölkühler, Ölwanne

Oil cooler, oil sump

**A07**

Radiateur d'huile, carter d'huile

Radiador de aceite, carter de aceite

Radiatore olio, coppa olio

Tafel Nr.

Tabl. No.

Tavola N.

**32**

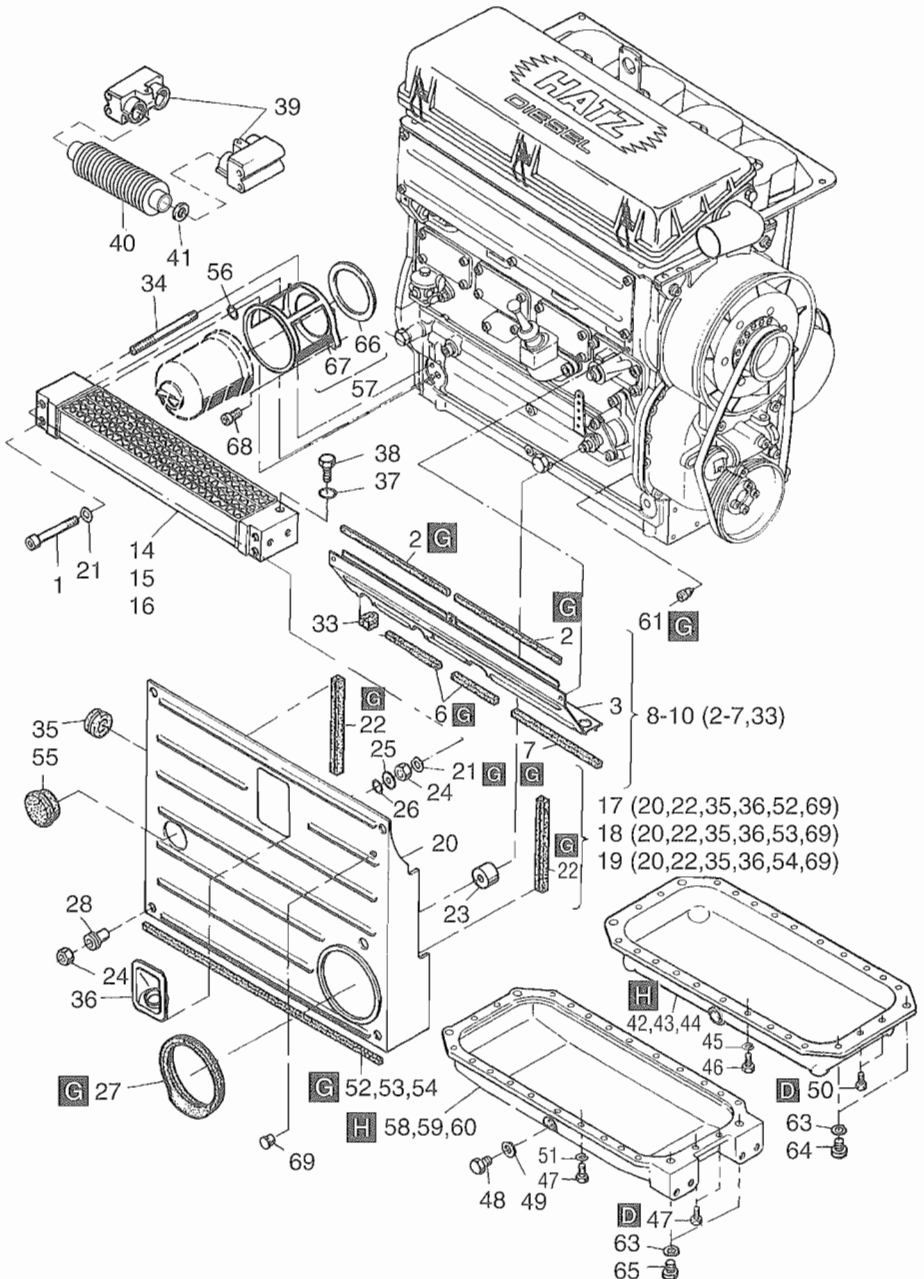

Fig.- No.	HATZ Ident-No.	Stück Qty.			P / W d / D	Bemerkungen Notes
		2 M . .	3 M . .	4 M . .		
1	50204100	2	2	2	M 8 x 95	DIN 6912-8.8
2	03564000	1	-	-	231 mm	
2	03563600	-	2	-	173 mm	
2	03572600	-	-	2	240 mm	
3	-----	-	-	-		
4	-----	-	-	-		
5	-----	-	-	-		
6	03598700	1	-	-	47 mm	
6	03565100	-	1	2	110 mm	
7	03598700	-	1	1	47 mm	
8	01181500	1	-	-		
9	01181600	-	1	-		
10	01181700	-	-	1		
11	-----	-	-	-		
12	-----	-	-	-		
13	-----	-	-	-		
14	03647801	1	-	-		
15	03647901	-	1	-		
16	03648001	-	-	1		
17	00743520	1	-	-		
18	00743720	-	1	-		
19	00746020	-	-	1		
20	-----	-	-	-		
21	50003500	4	4	4	B 8	DIN 137
22	03566200	2	2	2	168 mm	
23	03579400	1	1	1		
24	50022900	4	4	4	M 8	DIN 934-8
25	03595600	2	2	2		
26	03575500	2	2	2		
27	03594001	1	1	1		
28	00921400	2	2	2		
29	-----	-	-	-		
30	-----	-	-	-		
31	-----	-	-	-		
32	-----	-	-	-		

Ölkühler, Ölwanne

Oil cooler, oil sump

**A07**

Radiateur d'huile, carter d'huile

Radiador de aceite, carter de aceite

Radiatore olio, coppa olio

Tafel Nr.

Tabl. No.

Tavola N.

**32**

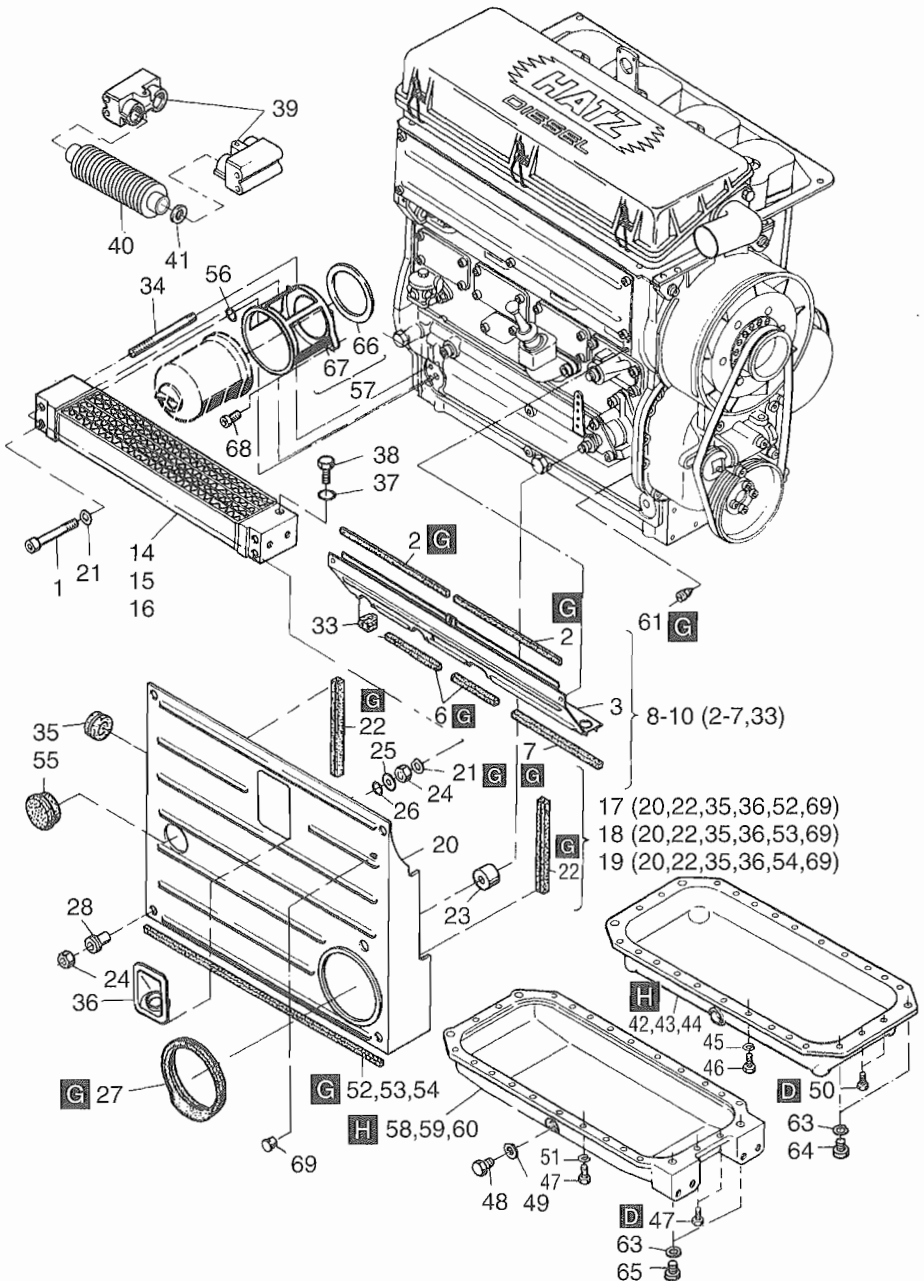

Fig.- No.	HATZ Ident-No.	Stück Qty.			P / W d / D	Bemerkungen Notes
		2 M . .	3 M . .	4 M . .		
33	03568900	3	3	3		
34	03581401	2	2	2		
35	05068700	1	1	1		
36	03761401	1	1	1		
37	50000900	1	1	1		A 8 x 11,5 DIN 7603-Cu
38	50137900	1	1	1		M 8 x 1 DIN 7604
39	03555310	2	-	-		} 1801...2600 min <sup>-1</sup> Gen.: 1500 + 1800 min <sup>-1</sup>
40	03555210	2	-	-		
41	50412900	4	-	-		
42	00917500	1	-	-		
43	00917600	-	1	-		
44	00917701	-	-	1		
45	50002800	8	14	24		8 DIN 128
46	50026700	8	14	24		M 8 x 16 DIN 933-8.8
47	50027000	12	18	24		8 x 25 DIN 933-8.8
48	50140400	1	1	1	W1	AM 22 x 1,5 DIN 7604-5.8
49	50001600	1	1	1	W4,D4	A 22 x 27 DIN 7603-Cu
50	50279300	4	4	-		M 8 x 16 DIN 933-8.8
51	50002800	8	14	24		8 DIN 128
52	03777100	1	-	-		203 mm
53	03777200	-	1	-		338 mm
54	03777300	-	-	1		473 mm
55	03769301	1	1	1		Ø 50 mm
56	50130400	2	2	2		
57	01247011	1	1	1		
58	03600500	1	-	-		
59	03600600	-	1	-		
60	03600701	-	-	1		
61	03465700	1	1	1		
62	- - - - -	-	-	-		
63	50003000	4	4	4		12 DIN 128
64	50080600	4	4	4		M 12 x 20 DIN 912-8.8
65	50057000	4	4	4		M 12 x 75 DIN 912-12.9
66	04008400	1	1	1		
67	- - - - -	-	-	-		
68	50385900	2	2	2		M 8 x 12 DIN 7984-8.8
69	40096000	1	1	1		F 17

**A08**

Anbaut. f. Zuluftschaft, Abluftschaft  
Air duct. adaption, air ducting  
Bati connexion, carter ventilation  
Bastidor de conex., chapa de aire  
Convogliatore uscita aria calda

Tafel Nr.  
Tabl. No.  
Tavola N.

**33**

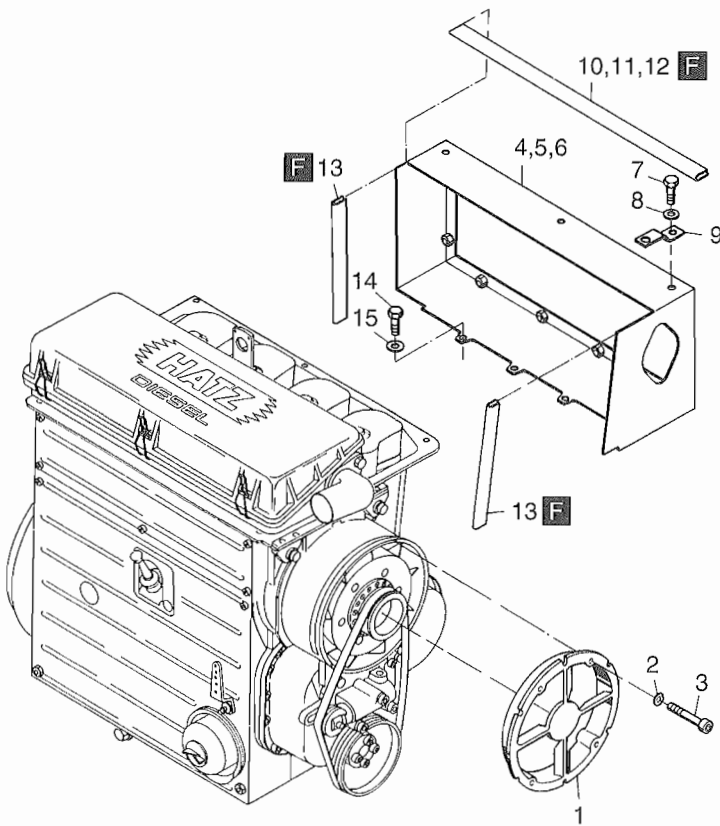

Fig.- No.	HATZ Ident-No.	Stück Qty.			P / W d / D	Bemerkungen Notes
		2 M . .	3 M . .	4 M . .		
1	03805200	1	1	1		
2	50081200	4	4	4	A 6	DIN 137 A3C
3	50198400	4	4	4	M 6 x 55	DIN 912-8.8
4	01488600	1	-	-		
5	01488700	-	1	-		
6	01488800	-	-	1		
7	50165500	2	3	3	M 6 x 12	DIN 933-8.8 A3C
8	50144500	2	3	3	6,4	DIN 125-St A3C
9	03899100	2	3	3		
10	03747100	1	-	-		
11	03747200	-	1	-		
12	03747300	-	-	1		
13	03747500	2	2	2		
14	50096200	4	6	7	M 8 x 12	DIN 933-8.8 A3C
15	50148100	4	6	7	8,4	DIN 125-St A3C

**A 12**

Keilriemenschutz  
V-belt guard  
Protecteur courrie  
Proteccion correa  
Protezione cinghia

**A 15**

Anschlußgehäuse  
Intermediate housing  
Bride raccord  
Caja de conexión  
Campana accoppiamento

Tafel Nr.  
Tabl. No.  
Tavola N.

**34**

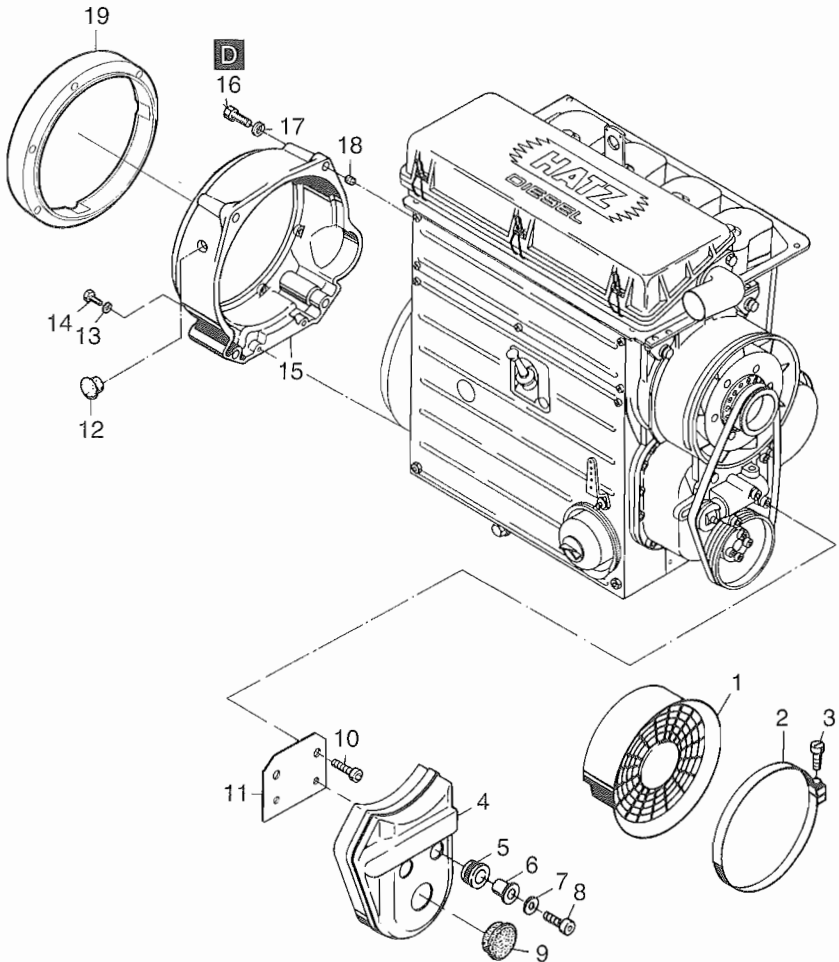

Fig.- No.	HATZ Ident-No.	Stück Qty.	P / W d / D	Bemerkungen Notes
		2..4M..		
1	03683900	1		
2	03802400	1		
3	50284300	1		M 4 x 30    DIN 84-4.8 A3C
4	03711001	1		
5	03665200	2		
6	03377600	2		
7	50114300	2		6,4            DIN 7349 Zn
8	50170600	2		M 6 x 20    DIN 912-8.8 A3C
9	50243000	1		F 33
10	50053000	2		M 8 x 70    DIN 912-8.8
11	03684002	1		
12	50237600	1		F 19
13	50002900	2		10            DIN 128
14	50029600	2		M 10 x 45    DIN 933-8.8
15	03575903	1		SAE 5
16	50137300	4		M 14 x 1,5 x 50    DIN 960-8.8
17	50003100	4		14            DIN 128
18	50137400	4		18 x 18      DIN 7346
19	03680300	1		



**A 16**

Elast. Kupplung  
Flexible coupling  
Acouplem. elastic  
Acoplamiento elast.  
Giunto elastico

**A 18**

Steuerdeckel für Hydraulik  
Timing cover hydr.  
Couvercle p. hydr.  
Tapa de mando p. hidraulico  
Coperchio per pompa idraulica

Tafel Nr.  
Tabl. No.  
Tavola N.

**35**

Fig.- No.	HATZ Ident-No.	Stück Qty.	P / W d / D	Bemerkungen Notes
		2..4M..		
1	00993501	1		
2	-----	-		
3	50126500	1		
4	50262000	2		10 x 10    DIN 7346
5	50002800	4		8            DIN 128
6	50258100	2		M 8 x 60    DIN 6912-8.8
7	01062300	1		
8	50268800	4		M 8 x 30    DIN 912-8.8
9	50162900	4		A 8 x 14    DIN 7603-Cu
10	03761600	1		
11	03568000	1		
12	03555011	1		
13	03754400	1		
14	50129100	1		
15	40022300	2		8 x 12 x 2
16	50052500	2		M 8 x 40    DIN 912-8.8
17	03754300	1		
18	50004600	1		M 8 x 15    DIN 916-45H
19	03040500	1		
20	03046900	6		
21	03151000	6		
22	03079000	6		20,3 x 26,9 x 4
23	50061600	6		12            DIN 7980

**Serien-Nr.-Änderungen**  
**Serial-code modification list**  
**Modification des Nos de serie**  
**Modificación de los Nos de serie**

**IMT.-No.**

2 M 31.11	2 M 31.12	89.487
3 M 31.11	3 M 31.12	89.487
4 M 31.11	4 M 31.12	89.487
2 M 40.15	2 M 40.16	89.487
3 M 40.15	3 M 40.16	89.487
4 M 40.15	4 M 40.16	89.487
2 M 31.12	2 M 31.13	89.488
2 M 31.13	2 M 31.14	91.513
3 M 31.12	3 M 31.13	89.488
3 M 31.13	3 M 31.14	91.513
4 M 31.12	4 M 31.13	89.488
4 M 31.13	4 M 31.14	91.513
2 M 40.16	2 M 40.17	89.488
2 M 40.17	2 M 40.18	91.513
3 M 40.16	3 M 40.17	89.488
3 M 40.17	3 M 40.18	91.513
4 M 40.16	4 M 40.17	89.488
4 M 40.17	4 M 40.18	91.513

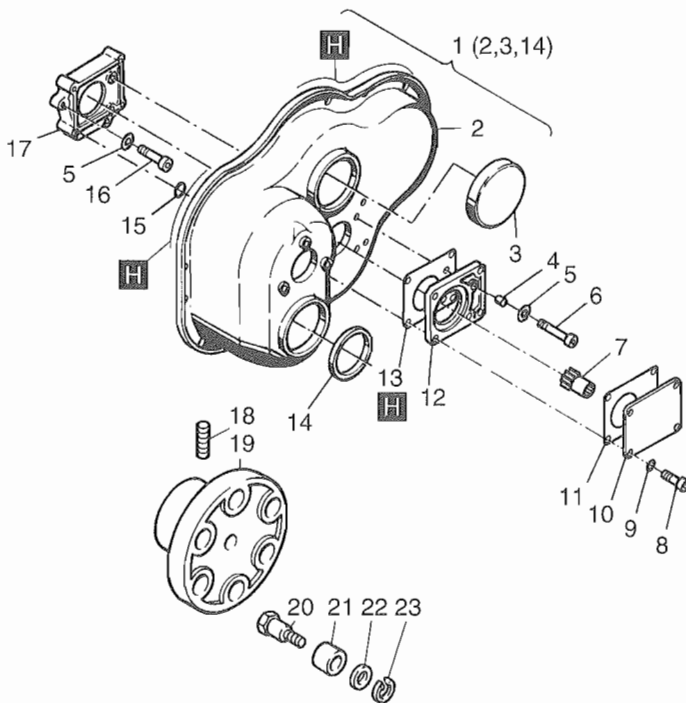