

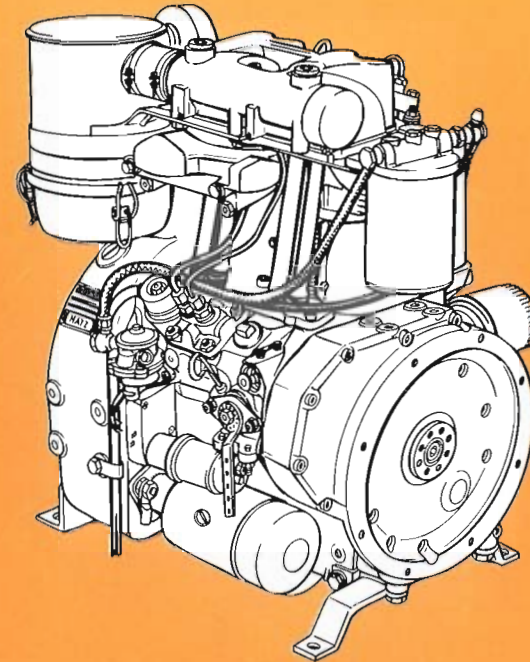

MOTORENFABRIK HATZ · D-94099 Ruhstorf · Germany
Tel. 085 31 / 319-0 · Telex 57 260 · Telefax 085 31 / 319 418

Ersatzteil-Liste
Spare parts list
Liste des pièces de rechange
Lista de recambios
Catalogo ricambi



33/359 - 7.94 - 3.
Printed in Germany

Schutzgebühr DM 3.-
Protection tax
Taxe de protection
Derecho de protección
Tassa di protezione

Z 788
Z 789
Z 790

No. Z 788.15
No. Z 789.15
No. Z 790.15

WICHTIG — Bitte Daten eintragen
IMPORTANT — Compléter les données

IMPORTANT — Please enter data
IMPORTANTE — Favor completar datos

1.

Bitte hier **Type, Motornummer** und **Drehzahl** (siehe Motor-Typenschild) eintragen.

Enter here **type engine no.** and **rpm.** (see engine type-plate).

Indiquer ici le **type, N° de moteur** et **régime** (voir plaque signalétique).

Insertar aquí **tipo- N° motor** y **r.p.m.** (vea placa del motor).

MOTORENFABRIK HATZ ^{GMBH & CO.} KG			
D-8399 RUHSTORF/ROTT			
TYP	KENNZ		
<input type="text"/>	<input type="text"/>		
MOTOR/FABRIK NO.		ABE/AUSF.	
<input type="text"/>	<input type="text"/>		
MIN ¹	NH	PV	CM ²
<input type="text"/>	<input type="text"/>	<input type="text"/>	<input type="text"/>
HATZ			
DIESEL			
MADE IN GERMANY (FED. REP.)			

1

2.

Bitte **Ersatzteillistennummer** (siehe Titelseite) gemäß Type ankreuzen, z. B. Typ Z 788.15

Z 788.15

Mark spare parts list no. (see title-page) acc. to type, e. g. for type Z 788.15

Z 788.15

Cocher le N° de liste de pièces de rechange (voir: couverture) selon type, par. ex. Z 788.15

Z 788.15

Marcar N° lista de recambios (ver: frontispició) de acuerdo aipo, ejemplo tipo Z 788.15

Z 788.15

Ersatzteilliste Nr.

Spare parts list no.

Liste des pièces de rechange no.

Lista de recambios no.

Z 788.15 Z 798.15 Z 790.15

2

3.

Bitte tragen Sie hier die **Anschrift** Ihrer nächsten HATZ-Service-stelle ein.

Insert here **address** of your next HATZ Service station.

Indiquer ici l'**adresse** de votre stationservice HATZ la plus proche.

Insertar aquí **dirección** de servicio HATZ más cercano.

3

MOTORENFABRIK HATZ
GmbH & Co. KG
D-94099 RUHSTORF a. d. Rott
Germany
☎ (08531) 319-0 · ☒ 5 7260

Angaben bei Ersatzteilbestellungen:

Zur richtigen und schnellen Belieferung mit Ersatzteilen sind folgende Angaben erforderlich:

1. **Type, Motornummer und Drehzahl** des Motors, für den das Ersatzteil benötigt wird: siehe Angaben auf Seite 1, Feld 1.
2. **Nummer der Ersatzteilliste**, aus der die Bestellnummer herausgelesen wurde: siehe Seite 1, Feld 2.
3. **Stückzahl und Bestell-Nr.** des gewünschten Ersatzteils.
4. Gewünschte **Versandart**, z. B. Post, Luftfracht, Express.
5. Genaue **Versandadresse**, wenn erforderlich mit Post- u. Bahnstation.

Bestellbeispiel:

Für Motortype: Z 788
Motornummer: 0481 594 018 863
min⁻¹ 3000/060

aus Ersatzteilliste Z 788.15

folgende Teile:

Stück	Bestell-Nr.
01	005 695 01
07	032 148 00

per Postexpress an

Die Ersatzteilbestellung richten Sie bitte an:

— die nächste HATZ-Servicestelle, Anschrift siehe Seite 1, Feld 3 oder separates Servicestellenverzeichnis

— oder an die

Motorenfabrik Hatz GmbH & Co. KG
D-94099 Ruhstorf a. d. Rott
Germany
☎ (0 85 31) 319-0 · ☎ 5 7260

Particulars for spare parts orders:

The following information is needed to ensure correct and prompt supply of spare parts:

1. **Engine type, engine number and r.p.m.** of the engine for which you need the spare part.
See particulars on page 1, field 1.
2. **Number of spare parts list** from which you took the ordering no., see page 1, field 2.
3. **Quantity and ordering no.** of requested spare part.
4. Requested **mode of dispatch**, e. g. surface / airmail, airfreight, express.
5. Exact **shipping address**, if necessary indicate local post office and/or railway station.

Example for your order:

For engine type: Z 788
Engine number: 0481 594 018 863
R. p. m.: 3000/060

Spare parts list no. Z 788.15

The following parts:

Qty.	ordering-no:
01	005 695 01
07	032 148 00

to be mailed, express, to

Please address your spare parts order to:

— your nearest Hatz service station, address see page 1, field 3 or separate Hatz-service-List

— or to

Motorenfabrik Hatz GmbH & Co. KG
D-94099 Ruhstorf a. d. Rott
Germany
☎ (0 85 31) 319-0 · ☎ 5 7260

Données à indiquer lors de vos commandes de pièces détachées:

Pour nous permettre de livrer vos pièces rapidement et correctement, nous avons besoin des données suivantes:

1. **Type, No. et régime du moteur** pour lequel vous avez besoin de pièces: voir données page 1, carré 1.
2. **No. de la liste de pièces de rechange** dans laquelle figure le No. de commande: voir page 1, carré 2.
3. **Quantité et No. de commande** de la pièce souhaitée.
4. **Mode d'expédition** souhaitée: par ex par poste, frêt aérien, exprès.
5. **Adresse exacte de destination** et, lorsque ceci est nécessaire, le nom de la poste ou de la gare, ou aeroport

Exemple:

Pour type de moteur: Z 788
No. moteur: 0481 594 018 863
Régime: 3000/060

Liste de pièces de rechange: Z 788.15

Les pièces suivantes:

Qté.	No. commande
01	005 695 01
07	032 148 00

par poste exprès à

Les commandes de pièces détachées sont à adresser à:

— votre station-service HATZ la plus proche, voir adresse page 1, carré 3 ou liste de service séparée.

— ou

Motorenfabrik Hatz GmbH & Co. KG
D-94099 Ruhstorf a. d. Rott
Allemagne
☎ (08531) 319-0 · ☎ 57260

Datos para pedidos de recambios:

Para recibir sus recambios en forma rápida y correcta necesitamos las siguientes informaciones:

1. **Tipo, número del motor y revoluciones:**
ver detalles en página 1, posición 1.
2. **Número de la lista de recambios** de la cual se ha obtenido el número de pedido: ver página 1, posición 2.
3. **Cantidad y número de pedido** del recambio deseado.
4. Tipo de **despacho deseado:** por ej. correo, flete aéreo, expreso etc.
5. **Dirección exacta**, si necesario indicar la oficina de correo, la estación ferrocarril o aeropuerto.

Ejemplo de pedido:

Para motor tipo: Z 788
Número de motor: 0481 594 018 863
R. P. M.: 3000/060

De la lista de recambios: Z 788.15

Siguientes recambios:

Cantidad	Número de pedido
01	005 695 01
07	032 148 00

Por correo expreso a

El pedido de recambios favor dirigirlo a:

— Al servicio HATZ más cercano, dirección verla en página 1, posición 3 o en el índice separado de direcciones de servicio.

— Alternativa a:

Motorenfabrik Hatz GmbH & Co. KG
D-94099 Ruhstorf a. d. Rott
Alemania
☎ (08531) 319-0 · ☎ 57260

	Inhaltsverzeichnis:	Index:	Tafel No. Table No.
M . . .	Grundmotor	Basic engine	
00, 34	Ersatzteilsätze, Zubehör	Spare part kits, accessories	01
01	Kurbelgehäuse	Crankcase	02
01, 10	Kurbelgehäuse, Ölpumpe	Crankcase, oil pump	03
02, 03	Kurbelwelle, Lagerflansch	Crankshaft, bearing flange	04
04	Nockenwelle, Regler,	Camshaft, governor, speed control	05
05, 06	Drehzahlverstellung Kolben, Pleuel, Zylinder	Piston, conrod, cylinder	06
07 - 09	Zylinderkopf	Cylinder head	07
11	Steuergehäuse	Governor housing	08
12 - 14 17, 26	Einspritzausrüstung, Schwungrad, Startfüllung, Luftführung	Injection equipment, flywheel, extra fuel device, air ducting	09
A . . .	Zusatzausrüstung	Equipments	
01	Kraftstoffbehälter, Förderpumpe, Filter, Leitungen	Fuel tank, fuel feed pump, filter, pipes	10
01	Filter, Leitungen	Filter, pipes	11
01	Förderpumpe, Leitungen	Fuel feed pump, pipes	12
02	Luftfilter	Air filter	13
03	Auspuffrohr, Auspufftopf	Exhaust manifold, exhaust silencer	14
04	Andrehrichtung schs.	Starting device	15
04	Dekompression	Decompression	16
05	Starter, Generator	Starter, alternator	17
05	Armaturenkasten	Instrument box	18
07	Öleinfüllung, Ölablaßrohr	Oil filling, oil drain tube	19
10	Absperrventil	Shut off valve,	20
16	Wellenstummel, elast. Kupplung	Stubshaft, flexible coupling	21
18	Hydraulik Ölkühler, Anbauteile Hydr.- Pumpe	Oil cooler, mount. parts hydr. pump	22
			Seite / Page
	Weitere Zusatzausrüstungen	Further additional equipment	65 - 66
	Änderungsübersicht	Modification table	67 - 69

Sommaire:**Indice:**

M . . .	Moteur de base	Motor de base	
00, 34	Jeux de pièces de rechange, accessoires	Juegos de piezas de recambio, accesorios	01
01	Carter moteur	Caja cigueñal	02
01, 10	Carter moteur, pompe a huile	Caja cigueñal, bomba de aceite	03
02, 03	Vilebrequin, palier	Cigüeñal, brida de cojinete	04
04	Abre à cames, regulateur, réglage régime	Arbol de levas, regulador, ajuste de revoluciones	05
05, 06	Piston, bielle, cylindre	Embolo, biela, cilindro	06
07 - 09	Culasse	Culata	07
11	Carter distribution	Caja de mando	08
12 - 14 17, 26	Equipement d'injection, volant, surcharge, carter ventilation	Equipo de inyección, volante, sobre aliment-arranque, conducción de aire	09
A . . .	Accessoires	Equipos	
01	Reservoir à carburant, pompe d'alimentation, filtre conduites	Depósito combustible, bomba de alimentación, filtro tubería	10
01	Filtre conduites	Filtro tubería	11
01	Pompe d'alimentation, conduites	Bomba de alimentación, tubería	12
02	Filtre à air	Filtro de aire	13
03	Tube d'échappement, silencieux	Tubo de escape, silenciador	14
04	Dispositif démarrage	Dispositivo de arranque	15
04	Décompression	Decompresión	16
05	Démarrreur, alternateur	Arrancador, alternador	17
05	Boltiere de bord	Cuadro de mando	18
07	Remplissage huile, tube de vidange	Tubuladura, tubo de purga	19
10	Soupape d'arrêt,	Valvula de parada	20
16	Bout d'arbre, accouplement elastique	Eje, acoplamiento elastico	21
18	Refroidisseur huile, pièce-mount. pompe hydr.	Radiador de aceite, piezas mont. bomba	22
			Page / Pagina No.
	Autres accessoires complémentaires	Itros equipos adicionales	65 - 66
	Aperçu de modification	Tabla de modificaciones	67 - 69

M00 Ersatzteilsätze
Spare parts kits
Jeux de pièces de rechange
Juegos de piezas de recambios
Serie guarnizioni

M34 Zubehör
Accessories
Accessoires
Accessorios
Kit accessori

Tafel Nr.
Tabl. No.
Tavola N.
01

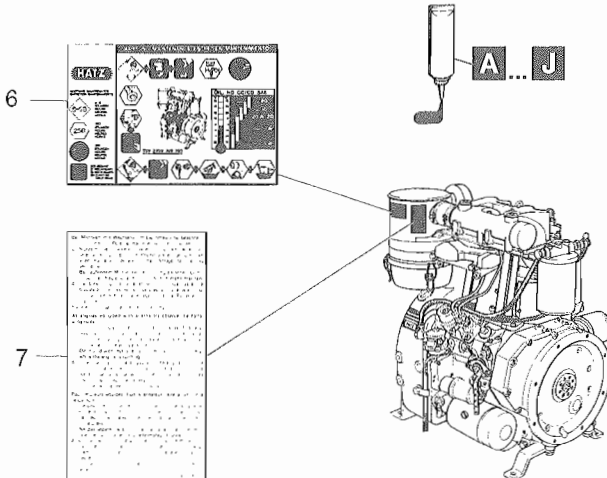
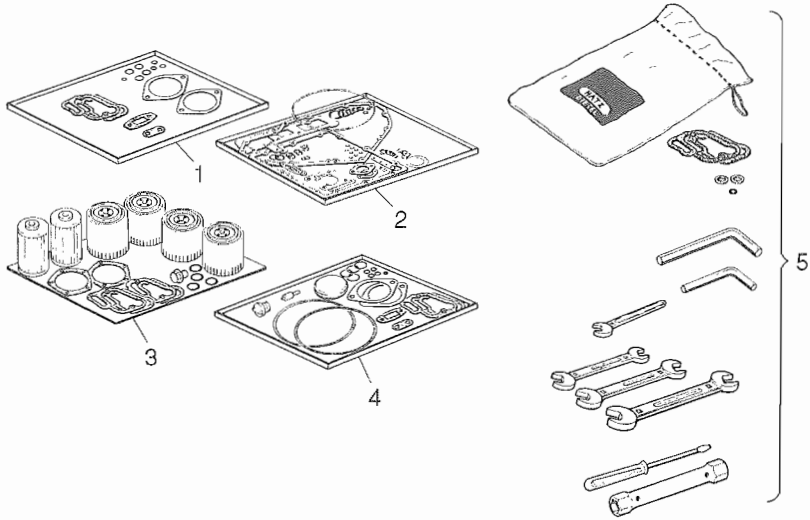

Fig. No.	Bestell-Nr. Ordering No. No. référence No. de pedido	Stück Quantity Quantités Cantidades	Hinweise Hints Indications Indicaciones		
----------	---	--	--	--	--

Z 788 | Z 789 | Z 790

P: Im Pannensatz enthalten. — Incl. in emergency kit. — Contenu dans le jeu secur. — Incluido en el juego para averias.

W: Im Wartungssatz enthalten. — Incl. in maintenance kit. — Contenu dans le jeu d'entretien. — Incluido en el juego de mantenimiento.

1: Anzahl pro Satz. — Qty. per kit. — Quantite par jeu. — Cantidad por juego.

d: Im Dichtungssatz f. 1 Zyl.-K. enthalten. — Incl. in gasket set f. 1 cyl. head. — Contenu dans le jeu de joint p. 1 culasse. — Incluido en el juego de juntas p. 1 culata.

D: Im Dichtungssatz Kurbelgeh. enth. — Incl. in gasket set crankcase. — Contenu dans le jeu de joints carter moteur. — Incluido en el juego de juntas caja cigueñal.

1	005 695 10 P1	2	2	2	Dichtungssatz für 1 Zylinderkopf Gasket set for 1 cyl. head Jeu de joint. p. 1 culasse Juego de juntas para 1 culata
2	012 302 00	1	1	1	Dichtungssatz Kurbelgehäuse Gasket set crankcase Jeu de joints carter moteur Juego de juntas caja cigueñal
3	009 618 01	1	1	1	Wartungssatz für 1000 h 1000 hours maintenance kit Kit d'entretien 1000 heures Juego de piezas para servicio 1000 horas
4	009 665 03	1	1	1	Pannensatz Emergency kit Kit de secours Juego para averias
5	005 324 00	1	1	1	Zubehörsatz Accessories kit Sort. accessoires Juego de accesorios
6	036 313 01	1	1	1	
7	034 306 12	1	1	1	

Dicht- und Klebstoffe
Sealing- and bonding adhesives

Etanchéifiant et Colle
Materias para empaquetar y pegar

A = 502 230 01	Loctite Activator N	— 500 ml
B = 502 231 00	Loctite 573	— 50 ml
C = 502 232 00	Loctite 601	— 50 ml
D = 502 233 00	Loctite 221	— 50 ml
E = 502 234 00	Loctite 648	— 10 ml
F = 502 238 00	Technicoll 8058	— 0,750 kg
+ 502 239 00	Technicoll 8366	— 0,750 kg
G = 502 565 01	Loctite IS 407	— 20 ml
H = 502 825 01	Silicon	— 30 ml
J = 502 830 01	Hochtemp. Paste	— 500 g

s. Hinweis auf den einzelnen Bildtafeln
as specified in the individual tables
suivant les remarques sur les tableau
correspondant
Según las indicaciones de las tablas
correspondientes

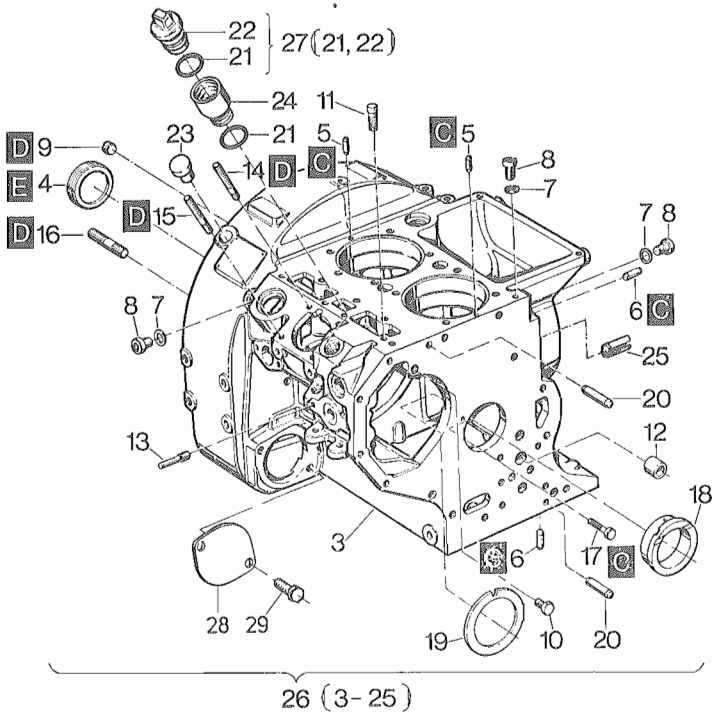

Fig. No.	Bestell-Nr. Ordering No. No. référence No. de pedido	Stück Quantity Quantités Cantidades			Hinweise Hints Indications Indicaciones	
		Z 788	Z 789	Z 790		
1	—	—	—	—		
2	—	—	—	—		
3	—	—	—	—		
4	—	—	—	—		
5	031 799 00	2	2	2		
6	032 123 00	2	2	2		
7	500 624 00 D1	3	3	3	A 10 x 13,5	DIN 7603 - Cu
8	500 623 00	3	3	3	M 10 x 1	DIN 908
9	500 437 00	1	1	1	M 12 x 1,5	DIN 906
10	032 723 01	1	1	1		
11	031 240 00	1	1	1		
12	032 167 00	1	1	1		
13	036 125 00	2	2	2		
14	500 381 00	2	2	2	M 8 x 25	DIN 939 - 5.6
15	500 380 00	2	2	2	M 8 x 25	DIN 938 - 5.6
16	500 401 00	4	4	4	M 10 x 20	DIN 835 - 8.8
17	032 986 00	1	1	1		
18	032 115 02	1	1	1		
18	032 623 02	1	1	1	— 0,5 mm	
19	035 582 00	1	1	1		
20	031 693 00	2	2	2		
21	501 538 00 D1	2	2	2		
22	—	—	—	—		
23	502 376 00	1	1	1		
24	036 584 00	1	1	1		
25	502 056 00	1	1	1	10 x 12	DIN 7346
26	005 643 02	1	1	1		
27	006 321 01 W1	1	1	1		
28	030 331 00	1	1	1		
29	500 308 00	2	2	2	M 12 x 16	DIN 933 - 8.8

M 01

Kurbelgehäuse
Crankcase
Carter moteur
Caja cigueñal

M 10

Ölpumpe
Oil pump
Pomp a huile
Bomba de aceite

Tafel Nr.
Tabl. No.

03

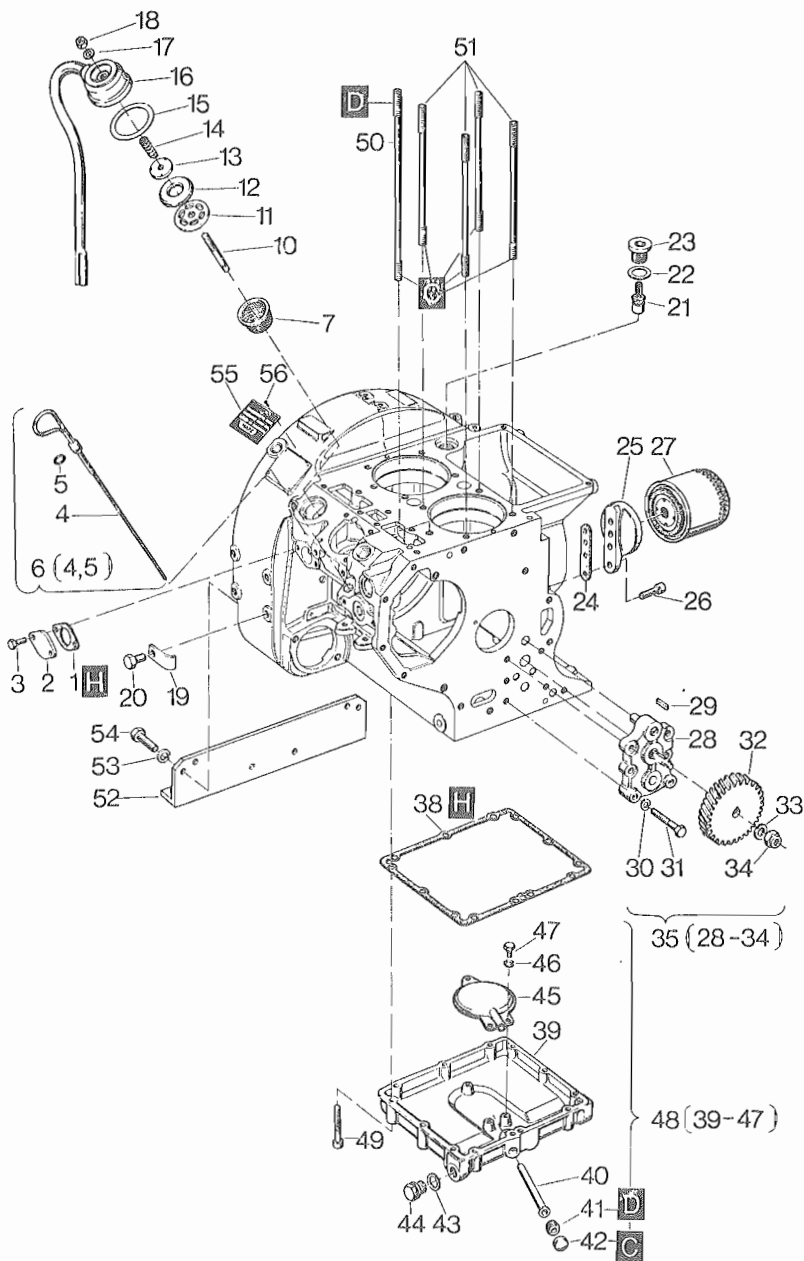

Fig. No.	Bestell-Nr. Ordering No. No. référence No. de pedido	Stück Quantity Quantités Cantidades			Hinweise Hints Indications Indicaciones	
		Z 788	Z 789	Z 790		
1	032 124 00 D1	1	1	—		
2	032 119 00	1	1	—		
3	500 254 00	2	2	—	M 6 x 10	DIN 933 - 8.8
4	—	—	—	—		
5	400 224 00 D1	1	1	1		
6	003 188 00	1	1	1		
7	031 804 00	1	1	1		
8	—	—	—	—		
9	—	—	—	—		
10	500 388 00	1	1	1	M 8x 55	DIN 835 - 5.6
11	030 501 00	1	1	1		
12	031 497 00	1	1	1		
13	031 588 00	1	1	1		
14	031 365 00	1	1	1		
15	031 589 00 D1	1	1	1		
16	003 635 00	1	1	1		
17	500 009 00 D7	1	1	1	A 8 x 11,5	DIN 7603 - Cu
18	400 284 00	1	1	1	M 8	SSN 440 - 8 Cu
19	034 380 00	1	1	1		
20	500 308 00	1	1	1	M 12 x 16	DIN 933 - 8.8
21	003 288 01	1	1	1		
22	500 016 00 D2	1	1	1	A 22 x 27	DIN 7603 - Cu
23	500 443 00	1	1	1	M 22 x 1,5	DIN 908
24	032 118 01 D1	1	1	1		
25	031 213 00	1	1	1		
26	500 519 00	2	2	2	M 8 x 20	DIN 912 - 8.8
27	400 381 00 W4	1	1	1		
28	—	—	—	—		
29	500 105 00	1	1	1	A 4 x 4 x 12	DIN 6885
30	500 028 00	5	5	5	8	DIN 128
31	500 275 00	5	5	5	M 8 x 35	DIN 931 - 8.8
32	031 227 00	1	1	1		
33	500 617 00	1	1	1	A 10	DIN 137
34	400 286 00	1	1	1	M 10	SSN 440 - 8 Cu
35	004 109 00	1	1	1		
36	—	—	—	—		

M 01

Kurbelgehäuse
Crankcase
Carter moteur
Caja cigueñal

M 10

Ölpumpe
Oil pump
Pomp a huile
Bomba de aceite

Tafel Nr.
Tabl. No.

03

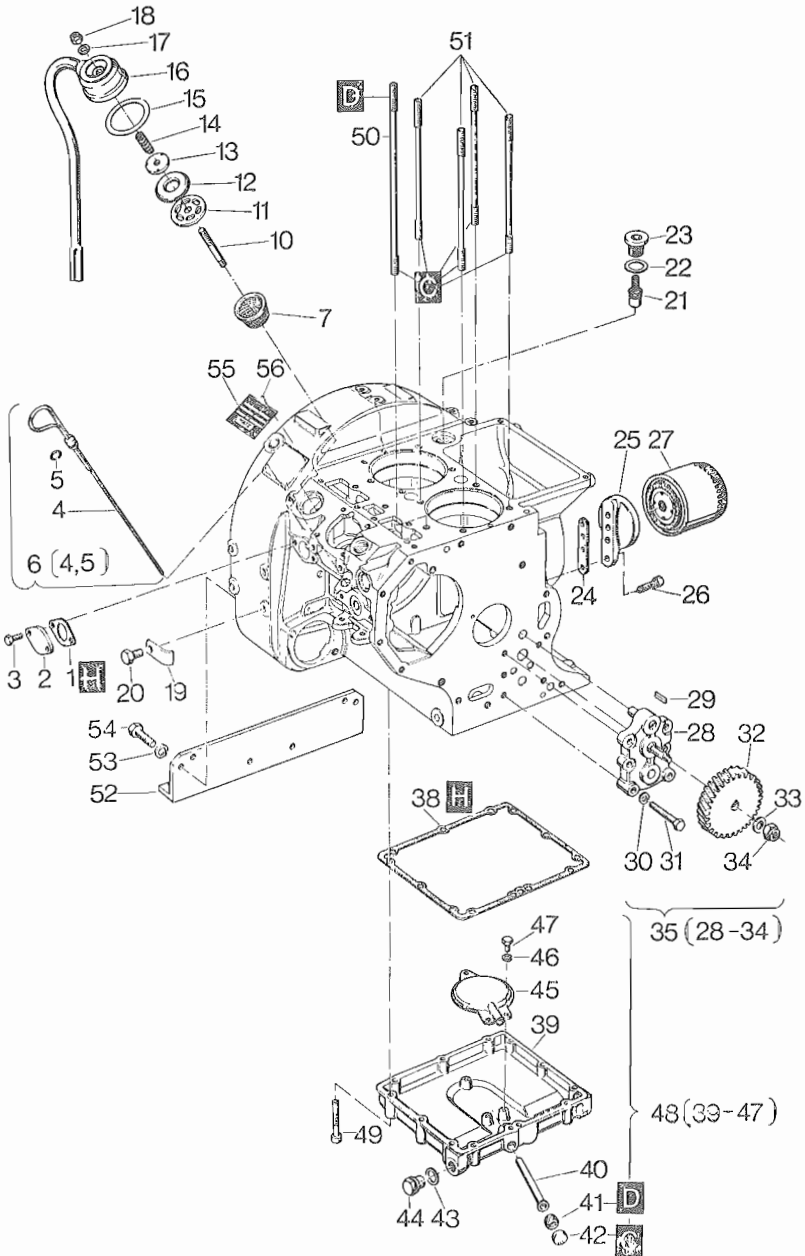

Fig. No.	Bestell-Nr.	Stück			Hinweise	
	Ordering No.	Quantity	Quantity	Quantity	Hints	
	No. référence	Quantités	Quantités	Quantités	Indications	
	No. de pedido	Cantidades	Cantidades	Cantidades	Indicaciones	
		Z 788	Z 789	Z 790		
37	—	—	—	—		
38	032 121 00 D1	1	1	1		
39	—	—	—	—		
40	032 584 02	1	1	1		
41	033 318 01	1	1	1		
42	500 431 00	1	1	1	18	DIN 443 - ROH
43	500 016 00 W4, D2	2	2	2	A 22 x 27	DIN 7603 - Cu
44	500 444 00 W1	2	2	2	CM 22 x 1,5	DIN 7604
45	032 120 00	1	1	1		
46	500 027 00	3	3	3	6	DIN 128
47	500 254 00	3	3	3	M 6 x 10	DIN 933 - 8.8
48	005 619 03	1	1	1		
49	500 808 00	12	12	12	M 8 x 42	DIN 912 - 8.8
50	033 409 00	2	2	2		
51	033 410 00	8	8	8		
52	031 215 00	1	1	1		
53	500 029 00	6	6	6	10	DIN 128
54	500 292 00	6	6	6	M 10 x 25	DIN 933 - 8.8
55	032 255 04	1	1	1		
56	400 025 00	4	4	4		

M 02

Kurbelwelle
Crankshaft
Vilebrequin
Cigüeñal

M 03

Lagerflansch
Bearing flange
Palier
Brida de cojinete

Tafel Nr.
Tabl. No.

04

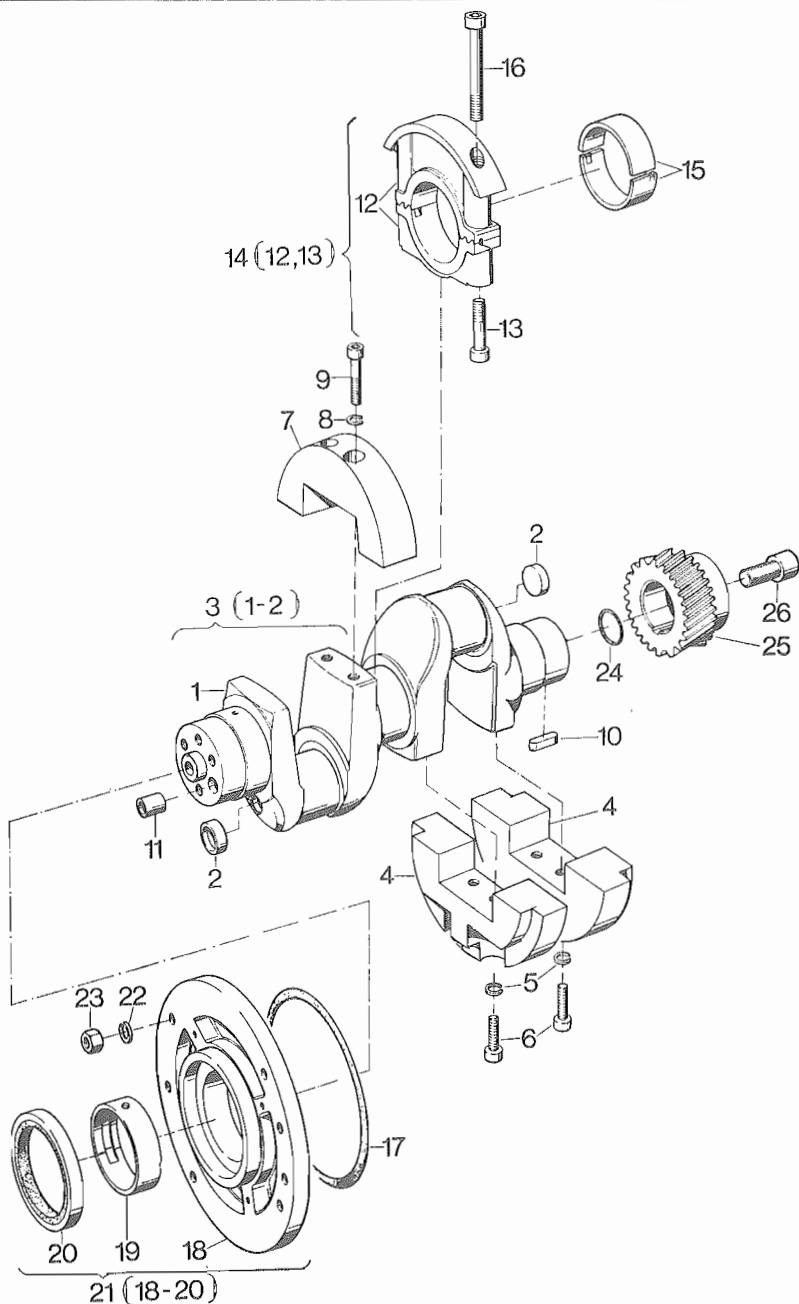

Fig. No.	Bestell-Nr. Ordering No. No. référence No. de pedido	Stück Quantity Quantités Cantidades			Hinweise Hints Indications Indicaciones	
		Z 788	Z 789	Z 790		
1	—	—	—	—		
2	500 432 00	2	2	2	25	DIN 443
3	006 445 00	1	—	—		
3	005 302 00	—	1	1		
4	031 216 02	2	2	2		
5	500 029 00	4	4	4	10	DIN 128
6	500 542 00	4	4	4	M 10 x 30	DIN 912 - 10.9
7	033 496 01	1	1	1		
8	500 029 00	2	2	2	10	DIN 128
9	500 548 00	2	2	2	M 10 x 45	DIN 912 - 10.9
10	500 112 00	1	1	1	A 6 x 6 x 25	DIN 6885
11	031 237 00	1	1	1		
12	—	—	—	—		
13	500 567 00	2	2	2	M 12 x 55	DIN 912 - 10.9
14	003 637 00	1	1	1		
15	032 134 00	1	1	1		
15	032 624 00	1	1	1	— 0,5 mm	
16	500 572 00	2	2	2	M 12 x 110	DIN 912 - 10.9
17	400 371 00 D1	1	1	1		
18	031 218 03	1	1	1		
19	032 135 00	1	1	1		
19	032 625 00	1	1	1	— 0,5 mm	
20	501 147 01 D1	1	1	1		
21	003 638 02	1	1	1		
22	500 029 00	4	4	4	10	DIN 128
23	500 235 00	4	4	4	M 10	DIN 934 - 8
24	400 234 00 D1	1	1	1	32 x 3	
25	031 202 00	1	1	1		
26	500 573 00	1	1	1	M 16 x 35	DIN 912 - 10.9

Nockenwelle, Regler, Drehzahlverstellung
Camshaft, governor, speed control
M 04 Abre à cames, regulateur, réglage régime
Arbol de levas, regulador, ajuste de revoluciones

Tafel Nr.
Tabl. No.

05

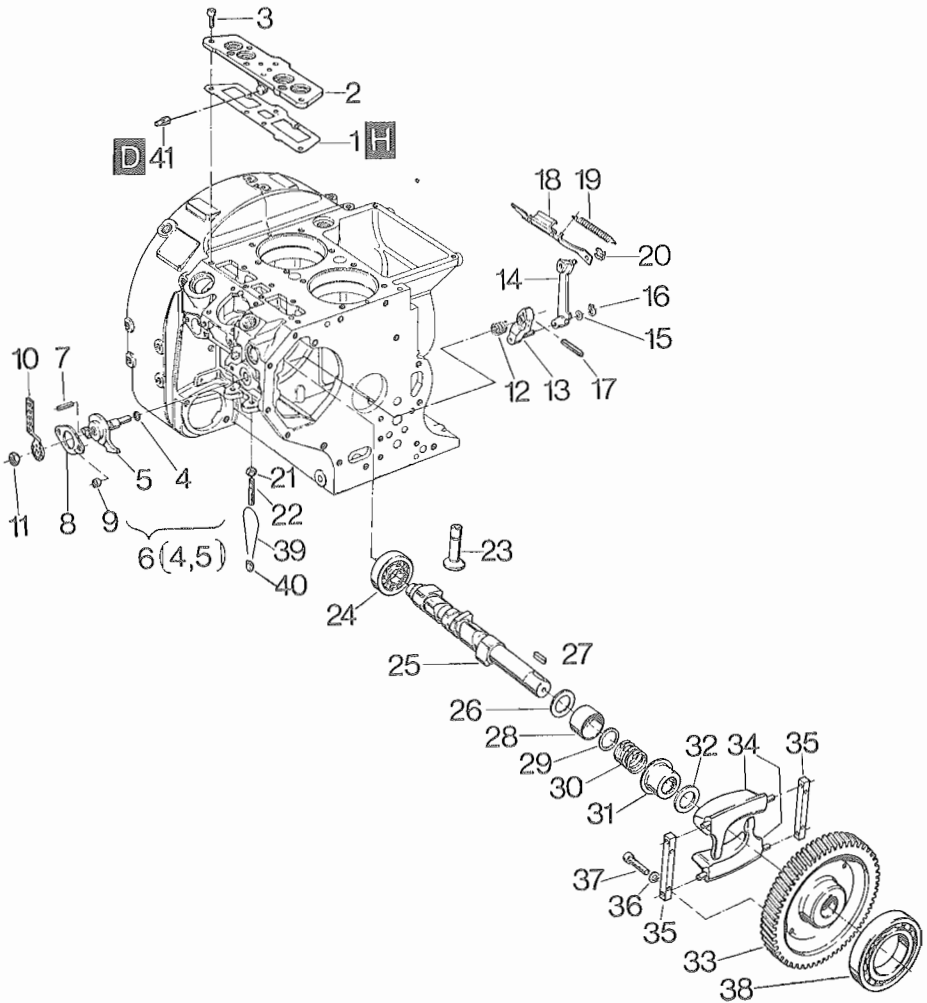

Fig. No.	Bestell-Nr. Ordering No. No. référence No. de pedido	Stück Quantity Quantités Cantidades			Hinweise Hints Indications Indicaciones	
		Z 788	Z 789	Z 790		
1	032 164 01 D1	1	1	1		
2	005 631 01	1	1	1		
3	500 518 00	7	7	7	M 8 x 18	DIN 912 - 8.8
4	400 817 00 D2	2	2	2	12 x 2	
5	—	—	—	—		
6	003 193 01	1	1	1		
7	500 345 00	1	1	1	4 x 14	DIN 1481
8	032 126 00	1	1	1		
9	400 284 00	2	2	2	M 8	SSN 440 - 8 Cu
10	032 116 00	1	1	1		
11	500 238 00	1	1	1	BM 10	DIN 439 - 6
12	032 122 01	1	1	1		
13	003 633 10	1	1	1		
14	003 634 00	1	1	1		
15	501 258 00	1	1	1	8 x 14 x 0,5	DIN 988
16	500 194 00	1	1	1	8 x 0,8	DIN 471
17	500 346 00	1	1	1	4 x 18	DIN 1481
18	004 112 01	1	1	1		
19	031 899 00	1	1	1		
20	400 141 00	1	1	1		
21	500 229 00	2	2	2	M 8	DIN 934 - 8
22	032 459 00	2	2	2		
23	032 117 00	4	4	4		
24	500 148 00	1	1	1		
25	033 458 01	1	1	1		
26	034 573 00	1	1	1		
27	500 112 00	1	1	1	A 6 x 6 x 25	DIN 6885
28	033 993 00	1	1	1		
29	034 426 01	1	1	1		
30	034 427 00	1	1	1	2,8 mm ϕ	1500 min ⁻¹
30	034 428 00	1	1	1	3,2 mm ϕ	1800 min ⁻¹
30	036 401 00	1	1	1	3,6 mm ϕ	< 2300 min ⁻¹
30	033 986 01	1	1	1	4,0 mm ϕ	> 2300 min ⁻¹
31	033 992 00	1	1	1		
32	034 425 00	1	1	1		
33	031 242 01	1	1	1		

Nockenwelle, Regler, Drehzahlverstellung
Camshaft, governor, speed control

Tafel Nr.
Tabl. No.

M 04

Abre à cames, regulateur, réglage régime
Arbol de levas, regulador, ajuste de revoluciones

05

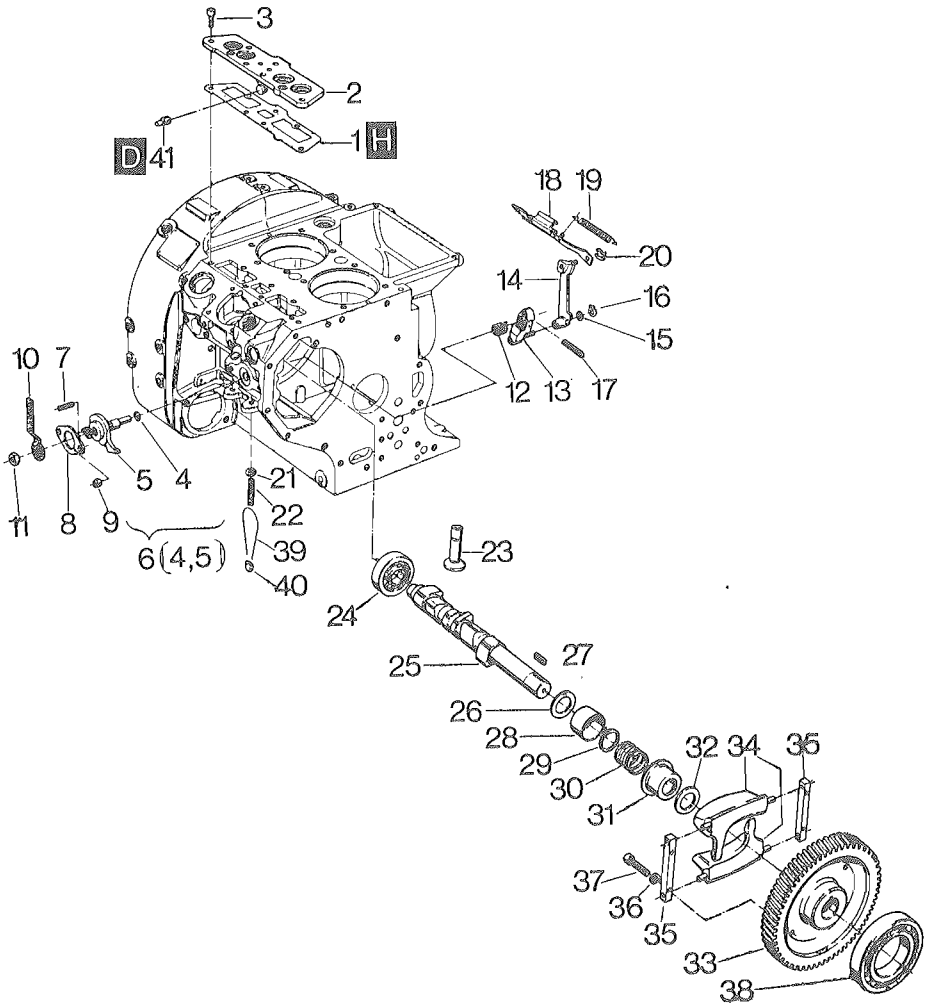

Fig. No.	Bestell-Nr. Ordering No. No. référence No. de pedido	Stück Quantity Quantités Cantidades			Hinweise Hints Indications Indicaciones
		Z 788	Z 789	Z 790	
34	033 984 00	2	2	2	
35	033 987 00	2	2	2	
36	500 028 00	4	4	4	8 DIN 128
37	034 576 00	4	4	4	
38	504 054 00	1	1	1	C5
39	400 215 00	1	1	1	
40	400 214 00	1	1	1	
41	037 742 00	1	1	1	

M 05

Kolben, Pleuel
Piston, conrod
Piston, bielle
Embolo, biela

M 06

Zylinder
Cylinder
Cilindre
Cilindro

TafelNr.
Tabl. No

06

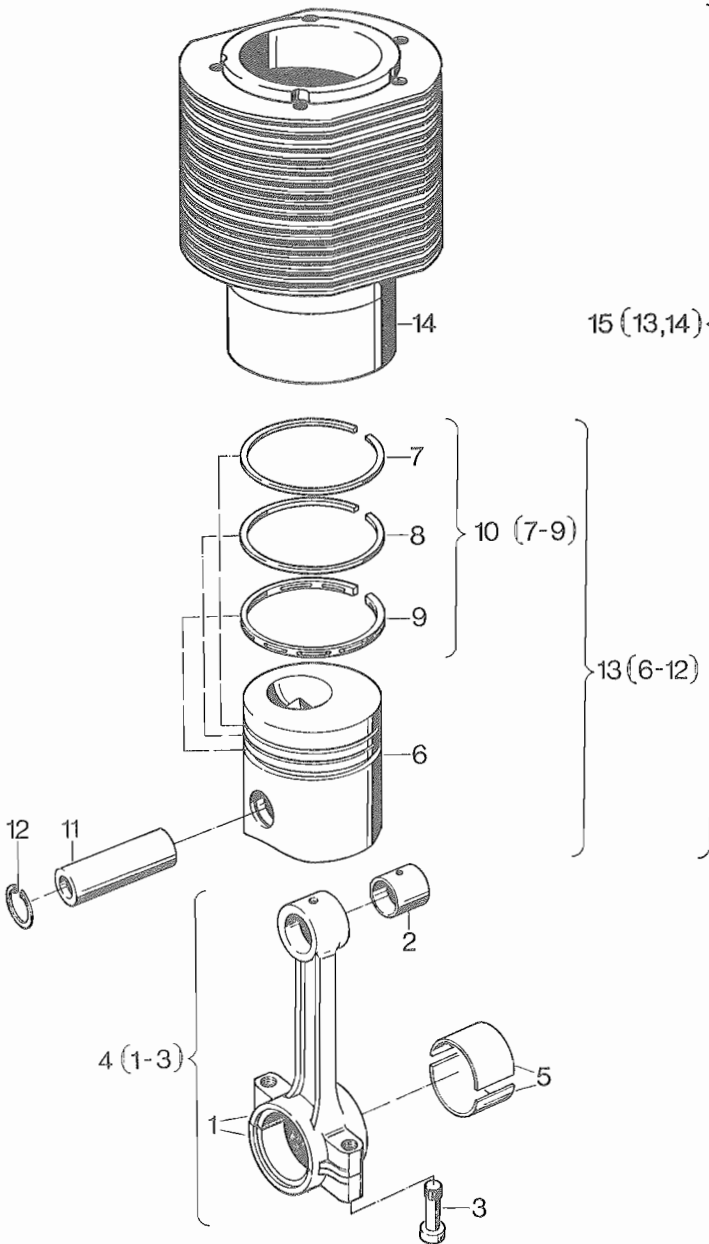

Fig. No.	Bestell-Nr. Ordering No. No. référence No. de pedido	Stück Quantity Quantités Cantidades			Hinweise Hints Indications Indicaciones
		Z 788	Z 789	Z 790	
1	—	—	—	—	
2	030 128 00	2	2	2	
3	031 704 00	4	4	4	
4	005 304 00	2	2	2	
5	033 413 00	2	2	2	
5	033 380 00	2	2	2	— 0,5 mm
6	—	—	—	—	
7	—	—	—	—	
8	—	—	—	—	
9	—	—	—	—	
10	012 385 00	2	2	2	
10	012 386 00	2	2	2	+ 0,5 mm
10	012 387 00	2	2	2	+ 1,0 mm
11	500 807 00	2	2	2	
12	500 207 00	4	4	4	28 x 1,2 DIN 472
13	006 391 02	2	—	—	
13	012 351 01	2	—	—	+ 0,5 mm
13	006 396 02	2	—	—	+ 1,0 mm
13	005 303 02	—	2	2	
13	012 352 01	—	2	2	+ 0,5 mm
13	005 678 02	—	2	2	+ 1,0 mm
14	—	—	—	—	
15	006 498 00	2	—	—	
15	005 668 00	—	2	2	

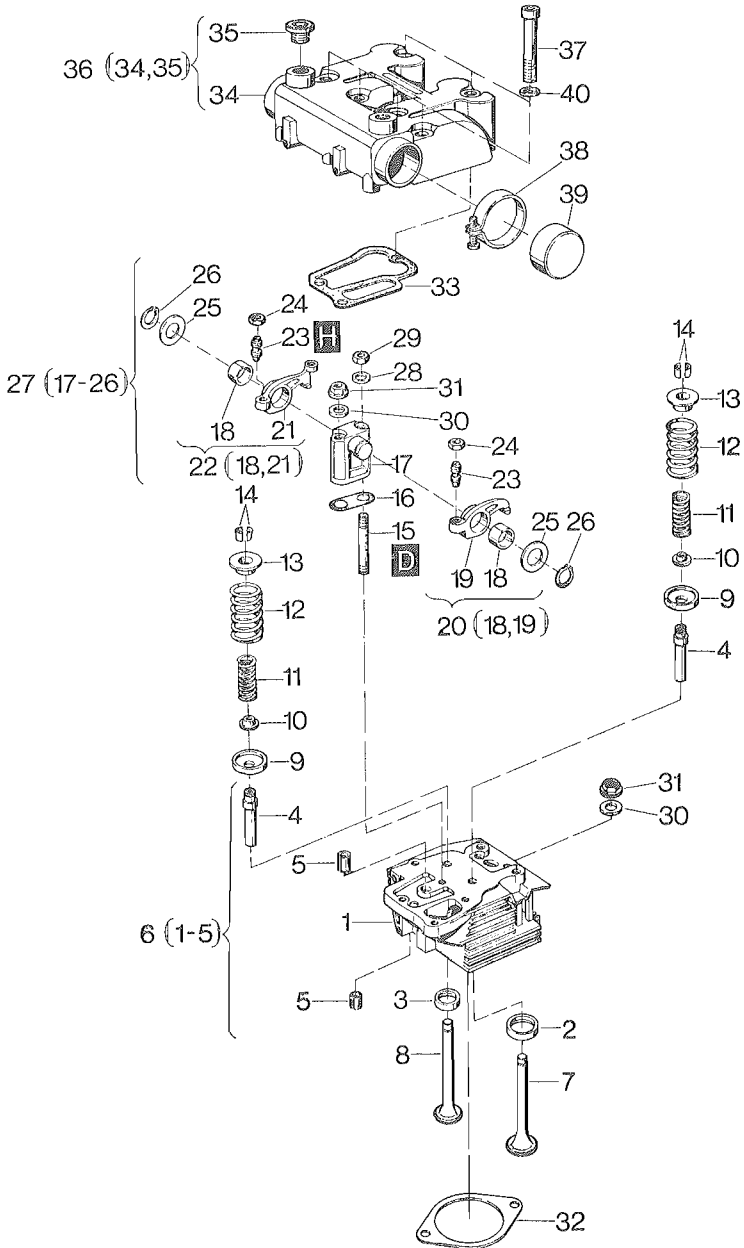

Fig. No.	Bestell-Nr.	Stück			Hinweise	
	Ordering No.	Quantity	Quantity	Quantity	Hints	
	No. référence	Quantités	Quantités	Quantités	Indications	
	No. de pedido	Cantidades	Z 788	Z 789	Z 790	
1	---	---	---	---		
2	---	---	---	---		
3	---	---	---	---		
4	033 257 10	4	4	4		
5	500 358 00	6	6	6	12 x 18	DIN 7346
6	006 030 10	2	2	2		
7	033 406 00	2	2	2		
8	033 405 00	2	2	2		
9	031 837 10	4	4	4		
10	031 844 10	4	4	4		
11	031 835 00	4	4	4		
12	033 256 00	4	4	4		
13	030 434 02	4	4	4		
14	032 926 00	4	4	4		
15	500 391 00	2	2	2	M 8 x 70	DIN 835 - 5.6
16	032 154 00 d1	2	2	2		
17	033 404 00	2	2	2		
18	031 841 00	4	4	4		
19	---	---	---	---		
20	005 325 00	2	2	2		
21	---	---	---	---		
22	005 326 02	2	2	2		
23	030 431 00	4	4	4		
24	031 490 00 W2	4	4	4		
25	032 332 00	0...4	0...4	0...4	0,20 mm	
25	032 333 00	0...4	0...4	0...4	0,30 mm	
25	034 560 00	0...4	0...4	0...4	0,40 mm	
26	500 202 00	4	4	4	19 x 1,2	DIN 471
27	005 633 00	2	2	2		
28	501 481 00 P2	2	2	2	8,4	DIN 125-St A3C
29	500 229 00 P2	2	2	2	M 8	DIN 934 - 8
30	032 148 00 P5	10	10	10		
31	032 150 00 P5	10	10	10		
32	033 416 00	0...2	0...2	0...2	0,5 mm	
32	033 417 00	0...2	0...2	0...2	0,6 mm	
32	033 418 00 d1	0...2	0...2	0...2	0,7 mm	

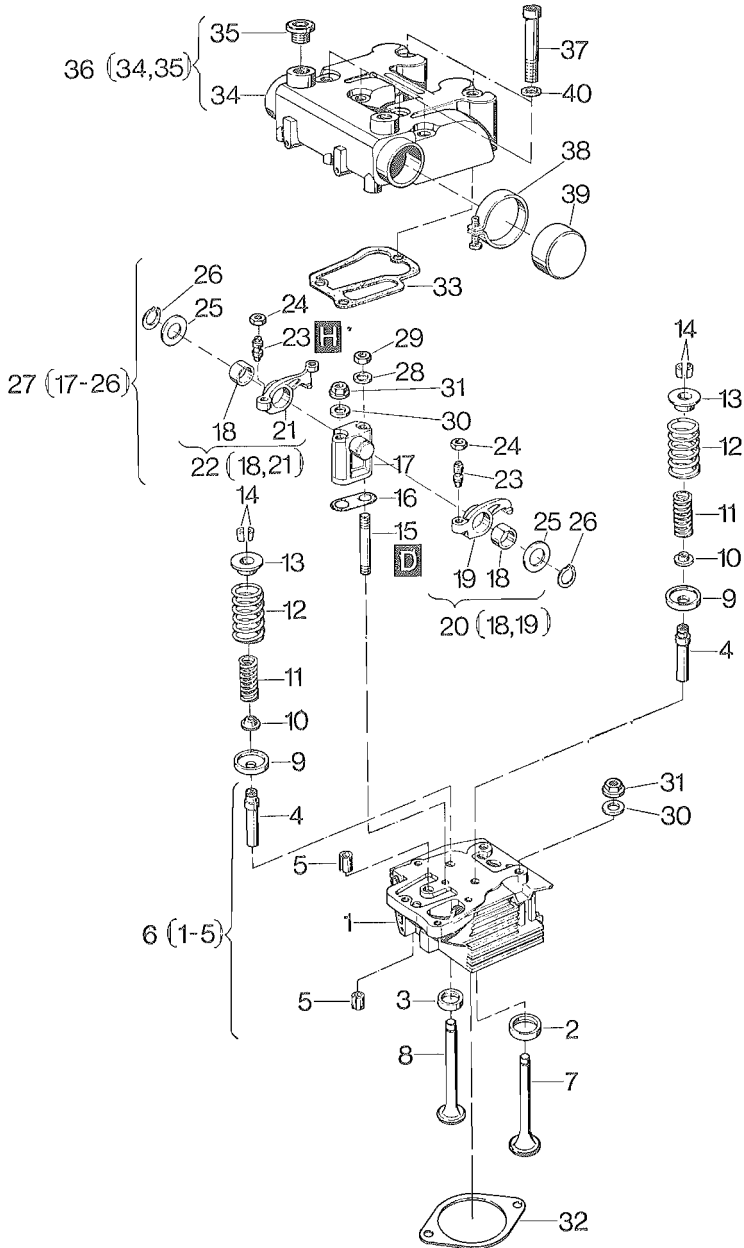

Fig. No.	Bestell-Nr. Ordering No. No. référence No. de pedido	Stück Quantity Quantités Cantidades			Hinweise Hints Indications Indicaciones
		Z 788	Z 789	Z 790	
32	033 419 00	0...2	0...2	0...2	0,8 mm
32	033 420 00 d1	0...2	0...2	0...2	0,9 mm
32	033 421 00	0...2	0...2	0...2	1,0 mm
32	033 422 00	0...2	0...2	0...2	1,1 mm
33	032 162 11 W4, d2	2	2	2	
34	—	—	—	—	
35	500 863 00	2	2	2	M 20 x 1,5 DIN 908
36	006 302 10	1	1	1	
37	501 209 00	6	6	6	M 8 x 85 DIN 912-8.8 A3C
38	400 955 00	1	1	1	
39	005 759 00	1	1	1	
40	032 148 00	6	6	6	

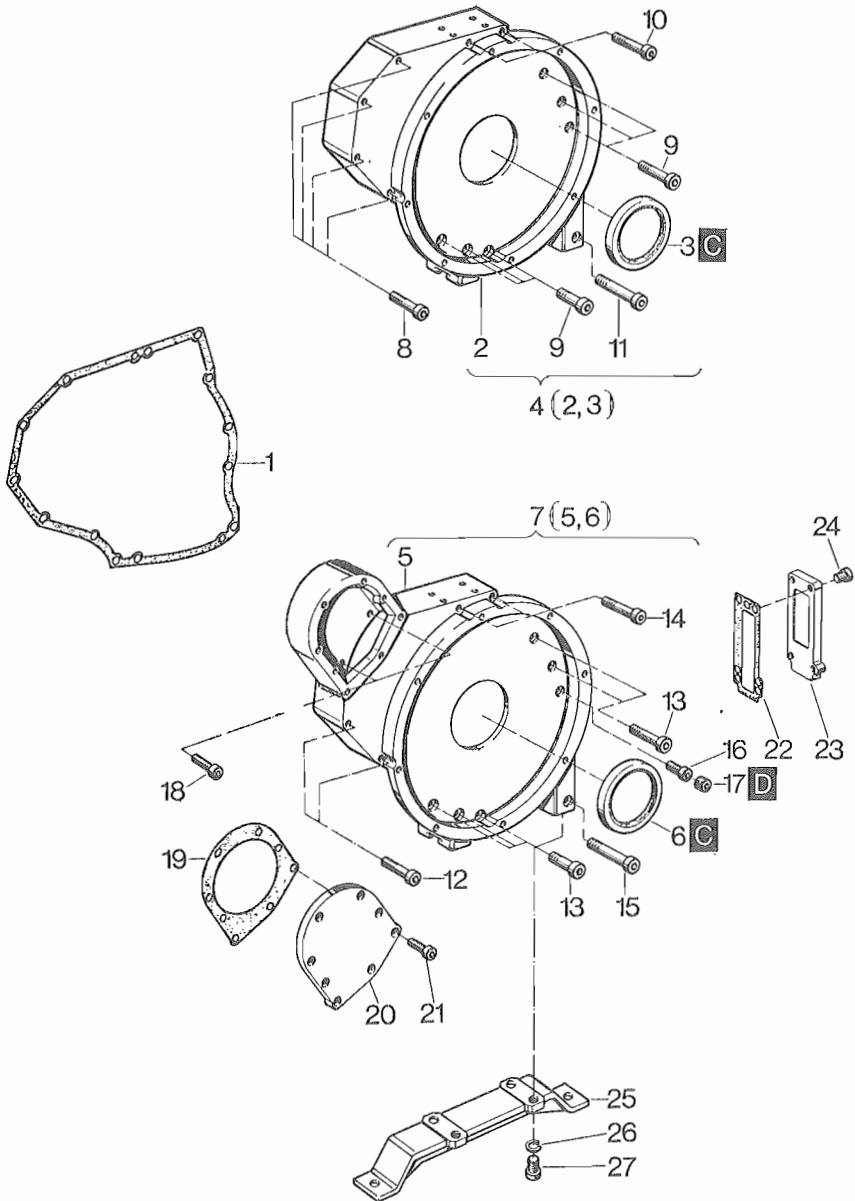

Fig. No.	Bestell-Nr. Ordering No. No. référence No. de pedido	Stück Quantity Quantités Cantidades			Hinweise Hints Indications Indicaciones	
		Z 788	Z 789	Z 790		
1	032 168 00 D1	1	1	1		
2	—	—	—	—		
3	400 347 00 D1	1	1	1		
4	003 646 01	1	1	1		
5	—	—	—	—		
6	400 347 00 D1	1	1	1		
7	004 115 01	1	1	1	„H“	
8	500 529 00	4	4	4	M 8 x 60	DIN 912 - 8.8
9	500 551 00	6	6	6	M 10 x 55	DIN 912 - 8.8
10	500 554 00	2	2	2	M 10 x 65	DIN 912 - 8.8
11	500 556 00	1	1	1	M 10 x 80	DIN 912 - 8.8
12	500 529 00	2	2	2	M 8 x 60	DIN 912 - 8.8
13	500 551 00	5	5	5	M 10 x 55	DIN 912 - 8.8
14	500 554 00	2	2	2	M 10 x 65	DIN 912 - 8.8
15	500 556 00	1	1	1	M 10 x 80	DIN 912 - 8.8
16	500 540 00	1	1	1	M 10 x 25	DIN 912 - 8.8
17	500 615 00	1	1	1	M 20 x 1,5	DIN 906
18	500 519 00	2	2	2	M 8 x 20	DIN 912 - 8.8
19	032 702 00 D1	1	1	1		
20	032 336 00	1	1	1		
21	500 519 00	6	6	6	M 8 x 20	DIN 912 - 8.8
22	032 704 00 D1	1	1	1		
23	032 337 00	1	1	1		
24	500 519 00	4	4	4	M 8 x 20	DIN 912 - 8.8
25	033 945 00	1	1	1		
26	502 637 00	4	4	4	A 12	DIN 127
27	500 311 00	4	4	4	M 12 x 28	DIN 933 - 8.8

Startfüllung	Einspritzaus- rüstung.	Schwungrad	Luftführung	Tafel Nr.
Extra fuel device	Injection equip- ment	Flywheel	Air ducting	Tabl. No.
M12 Surcharge	M14 Equipement d'in- jection	M17 Volant	M26 Carter ventila- tion	
Sobre allent- arranque	Equipo de inyec- ción	Volante	Conducción de aire	09

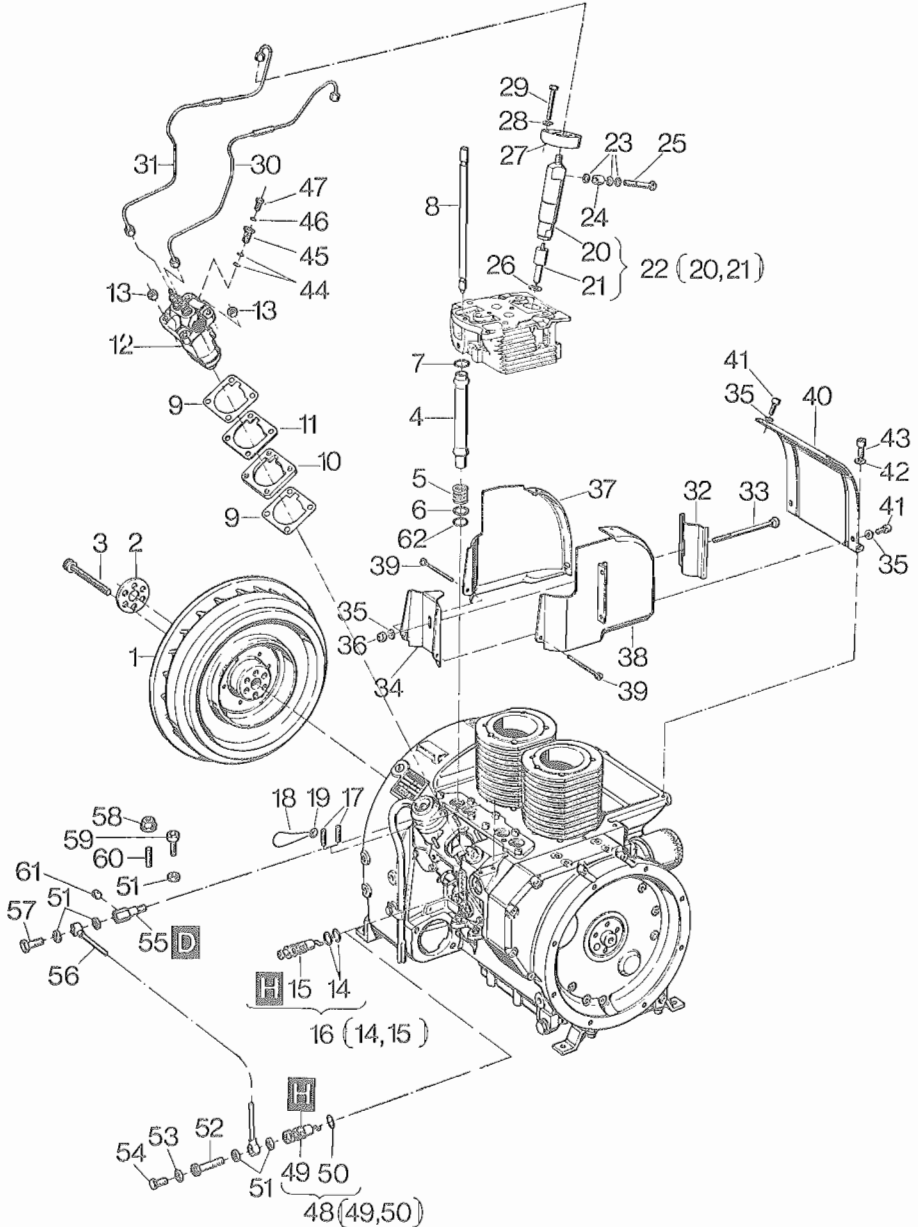

Fig. No.	Bestell-Nr. Ordering No. No. référence No. de pedido	Stück Quantity Quantités Cantidades			Hinweise Hints Indications Indicaciones
		Z 788	Z 789	Z 790	
1	034 342 01	1	1	1	
2	032 169 00	1	1	1	
3	500 570 00	6	6	6	6 BKM 12x75 DIN 912 - 12.9
4	032 163 00	4	4	4	
5	031 851 00	4	4	4	
6	031 852 00	4	4	4	
7	502 580 00 d2	4	4	4	17 x 3
8	003 644 00	4	4	4	
9	031 907 00 D2	2	2	2	
10	030 538 01	1	1	1	
11	031 906 01	0...1	0...1	0...1	0,20 mm
11	031 908 00	0...1	0...1	0...1	0,30 mm
11	031 909 00	0...1	0...1	0...1	0,50 mm
12	400 057 11	1	1	—	
12	400 721 10	—	—	1	
13	500 229 00	4	4	4	M 8 DIN 934 - 8
14	400 229 00 D2	2	2	2	
15	—	—	—	—	
16	003 416 01	1	1	1	
17	032 722 00	2	2	2	
18	400 215 00	1	1	1	
19	400 214 00	1	1	1	
20	—	—	—	—	
21	400 724 00 P1	2	2	2	
22	400 725 00	2	2	2	
23	500 009 00 d3, D7	6	6	6	A 8 x 11,5 DIN 7603 - Cu
24	032 929 00	2	2	2	
25	032 928 00	2	2	2	
26	400 558 00 d1	2	2	2	
27	032 850 00	2	2	2	
28	500 028 00 P4	4	4	4	8 DIN 128
29	500 281 00	4	4	4	M 8 x 50 DIN 931 - 8.8
30	033 425 00	1	1	1	
31	033 426 00	1	1	1	
32	031 254 01	1	1	1	
33	500 633 00	1	1	1	M 6 x 120 DIN 603 - 4.6

Startfüllung	Einspritzaus- rüstung,	Schwungrad	Luftführung	Tafel Nr.
Extra fuel device	Injection equip- ment	Flywheel	Air ducting	Tabl. No.
M12 Surcharge	M14 Equipement d'in- jection	M17 Volant	M26 Carter ventila- tion	
Sobre aliment- arranque	Equipo de Inyec- ción	Volante	Conducción de aire	09

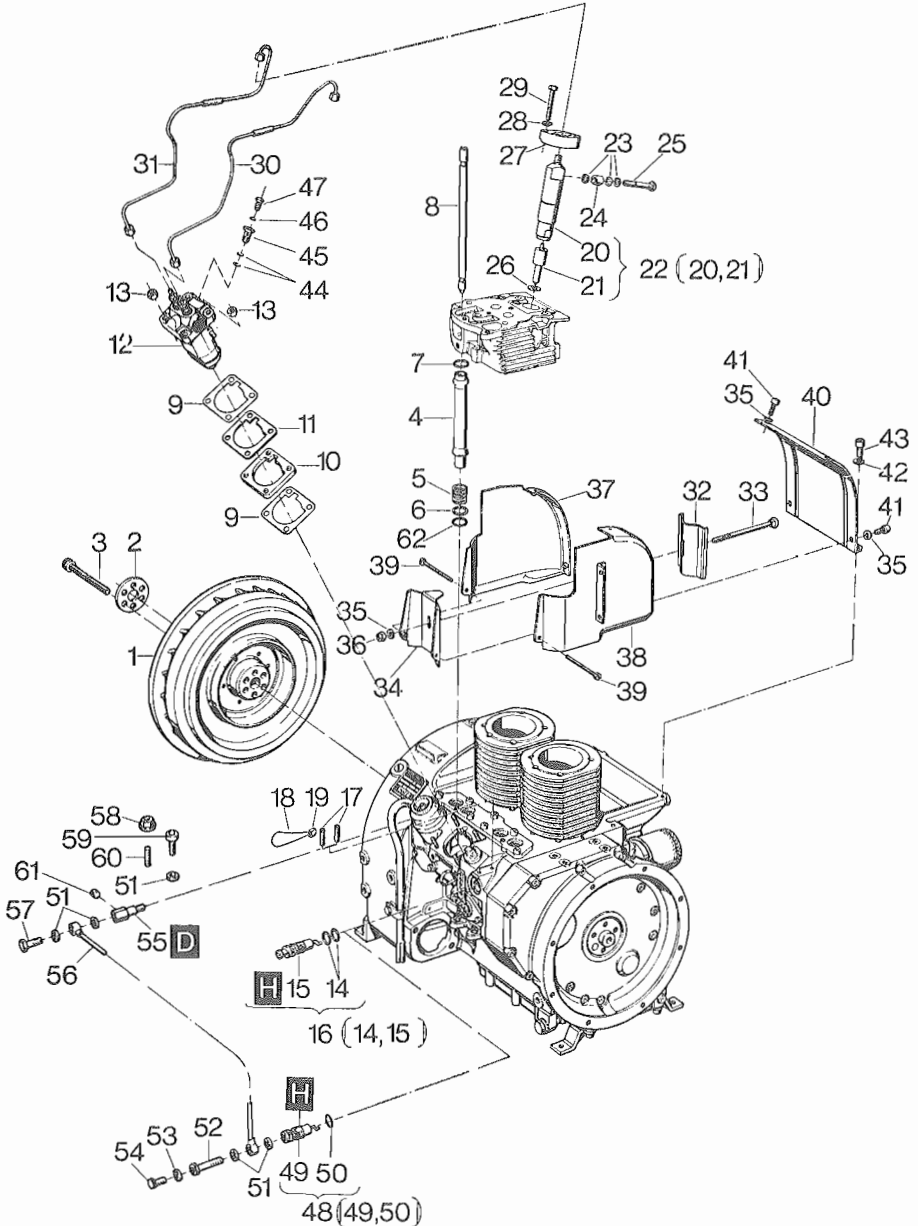

Fig. No.	Bestell-Nr. Ordering No. No. référence No. de pedido	Stück Quantity Quantités Cantidades			Hinweise Hints Indications Indicaciones	
		Z 788	Z 789	Z 790		
34	003 689 00	1	1	1		
35	501 445 00	5	5	5	6,4	DIN 125-St A3C
36	400 283 00	1	1	1	M 6	SSN 440 - 8 Cu
37	006 097 00	1	1	1		
38	006 098 00	1	1	1		
39	500 496 00	2	2	2	AM 5 x 60	DIN 84 - 4.8
40	031 229 02	1	1	1		
41	500 627 00	4	4	4	M 6 x 10	DIN 912 - 8.8
42	500 028 00	2	2	2	8	DIN 128
43	500 514 00	2	2	2	M 8 x 12	DIN 912 - 8.8
44	500 011 00 D2	2	2	2	A 12 x 15,5	DIN 7603 - Cu
45	036 135 00	1	1	1		
46	500 008 00	1	1	1	A 6,5 x 9,5	DIN 7603 - Cu
47	036 136 00	1	1	1		
48	008 749 00	1	1	1		
49	—	—	—	—		
50	501 691 00 D1	1	1	1		
51	500 009 00 D7	5	5	5	A 8 x 11,5	DIN 7603-Cu
52	037 248 00	1	1	1		
53	500 008 00 D1	1	1	1		
54	500 253 00	1	1	1		
55	037 026 01	1	1	1		
56	010 066 00	1	1	1		
57	039 462 00	1	1	1		
58	501 836 00	1	1	1	M 8	SEAL LOCK
59	037 016 00	1	1	1		
60	036 574 00	1	1	1		
61	500 436 00	1	1	1	M 10 x 1	DIN 906
62	400 228 00 d2	4	4	4	15 x 3,2	

Kraftstoffbehälter, Förderpumpe, Filter, Leitungen

Fuel tank, fuel feed pump, filter, pipes

Reservoir à carburant, pompe d'alimentation, filtre conduites

Depósito combustible, bomba de alimentación, filtro tubería

Tafel Nr.

Tabl. No.

10

A 01

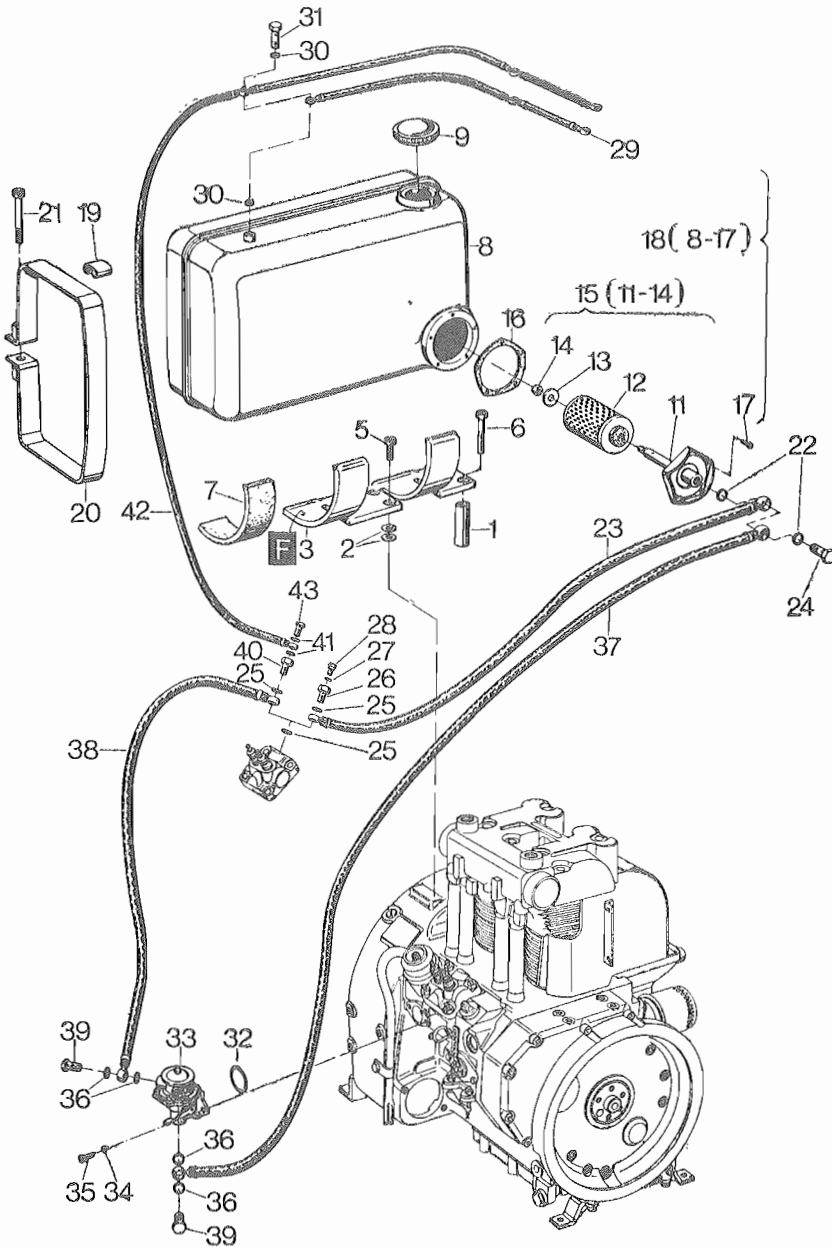

Fig. No.	Bestell-Nr. Ordering No. No. référence No. de pedido	Stück Quantity Quantités Cantidades			Hinweise Hints Indications Indicaciones	
		Z 788	Z 789	Z 790		
1	031 233 00	2	2	2		
2	501 459 00	4	4	4	B 10,5	DIN 125-St A3C
3	032 175 00	1	1	1		
5	500 540 00	2	2	2	M 10 x 25	DIN 6912 - 8.8
6	500 558 00	2	2	2	M 10 x 85	DIN 6912 - 8.8
7	400 114 00	2	2	2		
8	—	—	—	—		
9	400 327 00 P1	1	1	1		
10	—	—	—	—		
11	004 204 00	1	1	1		
12	400 073 00 W2	1	1	1		
13	500 629 00 W1	1	1	1	B 8,4	DIN 9021 - St
14	400 284 00 W1	1	1	1	VM 8	DIN 980-8 A3C
15	003 497 00	1	1	1		
16	031 884 01 W2	1	1	1		
17	500 627 00 W5	5	5	5	M 6 x 10	DIN 912 - 8.8
18	005 104 00	1	1	1		
19	031 886 00	2	2	2		
20	007 788 00	4	4	4		
21	035 377 00	4	4	4		
22	500 012 00 D2	2	2	2	A 14 x 18	DIN 7603 - Cu
23	032 804 00	1	1	1	470 mm	
24	500 064 00	1	1	1	A 8	DIN 7623
25	500 011 00 D2	2	2	2	A 12 x 15,5	DIN 7603 - Cu
26	036 135 00	1	1	1		
27	500 008 00	1	1	1	A 6,5 x 9,5	DIN 7603 - Cu
28	036 136 00	1	1	1		
29	034 096 00	1	1	1	558 mm	
30	500 009 00 D7	2	2	2	A 8 x 11,5	DIN 7603 - Cu
31	500 061 00	1	1	1	A 2/3	DIN 7623
32	501 299 00 D1	1	1	1		
33	400 374 00	1	1	1		
34	500 812 00	2	2	2	A 6	DIN 137
35	500 507 00	2	2	2	M 6 x 16	DIN 912 - 8.8
36	500 012 00 W4, D2	4	4	4	A 14 x 18	DIN 7603 - Cu
37	032 755 00	1	1	1	550 mm	

Kraftstoffbehälter, Förderpumpe, Filter, Leitungen

Tafel Nr.

Fuel tank, fuel feed pump, filter, pipes

Tabl. No.

A 01

Reservoir à carburant, pompe d'alimentation, filtre conduites

Depósito combustible, bomba de alimentación, filtro tubería

10

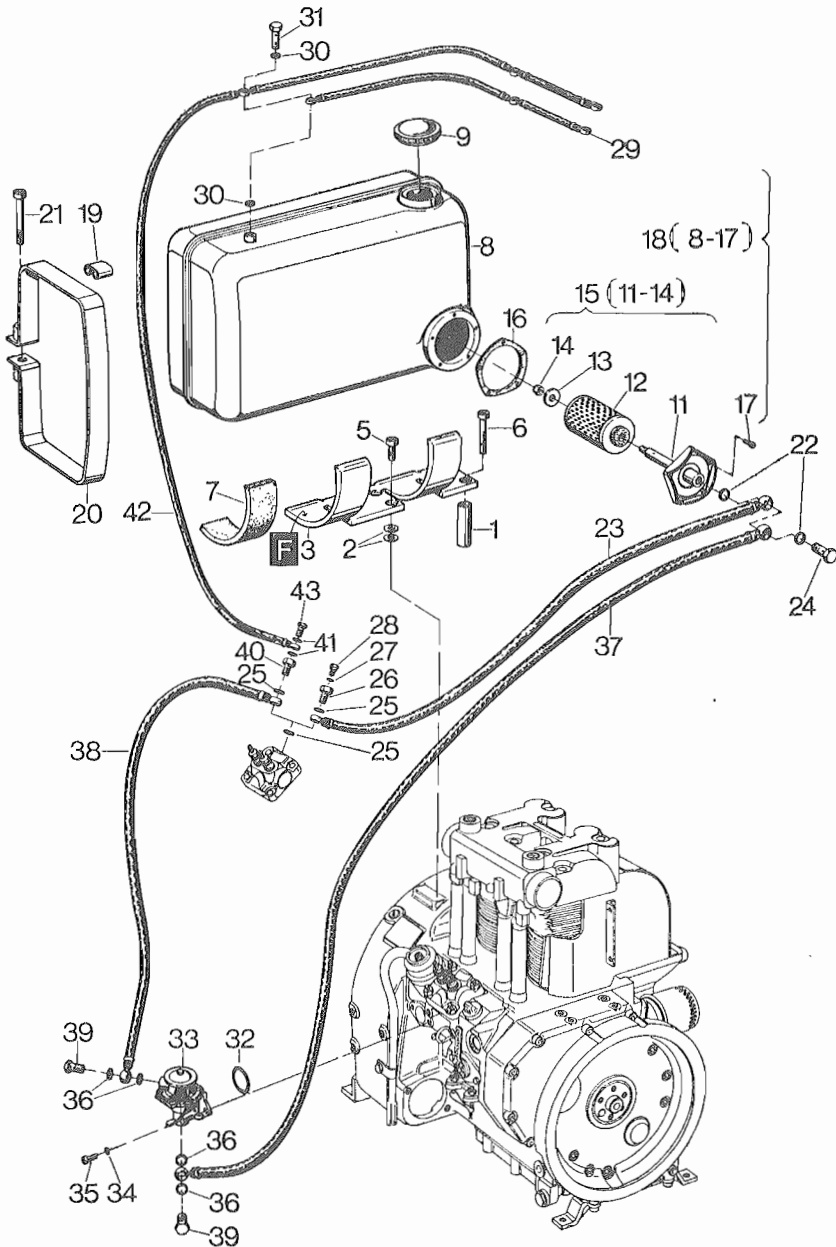

Fig. No.	Bestell-Nr. Ordering No. No. référence No. de pedido	Stück Quantity Quantités Cantidades			Flinweise Hints Indications Indicaciones	
		Z 788	Z 789	Z 790		
38	038 107 00	1	1	1	225 mm	
39	500 064 00	2	2	2	A 8	DIN 7623
40	034 077 00	1	1	1		
41	500 009 00 D7	2	2	2	A 8 x 11,5	DIN 7603 - Cu
42	034 081 00	1	1	1	1078 mm	
43	500 061 00	1	1	—	A 2/3	DIN 7623 Zn
43	037 479 00	—	—	1		

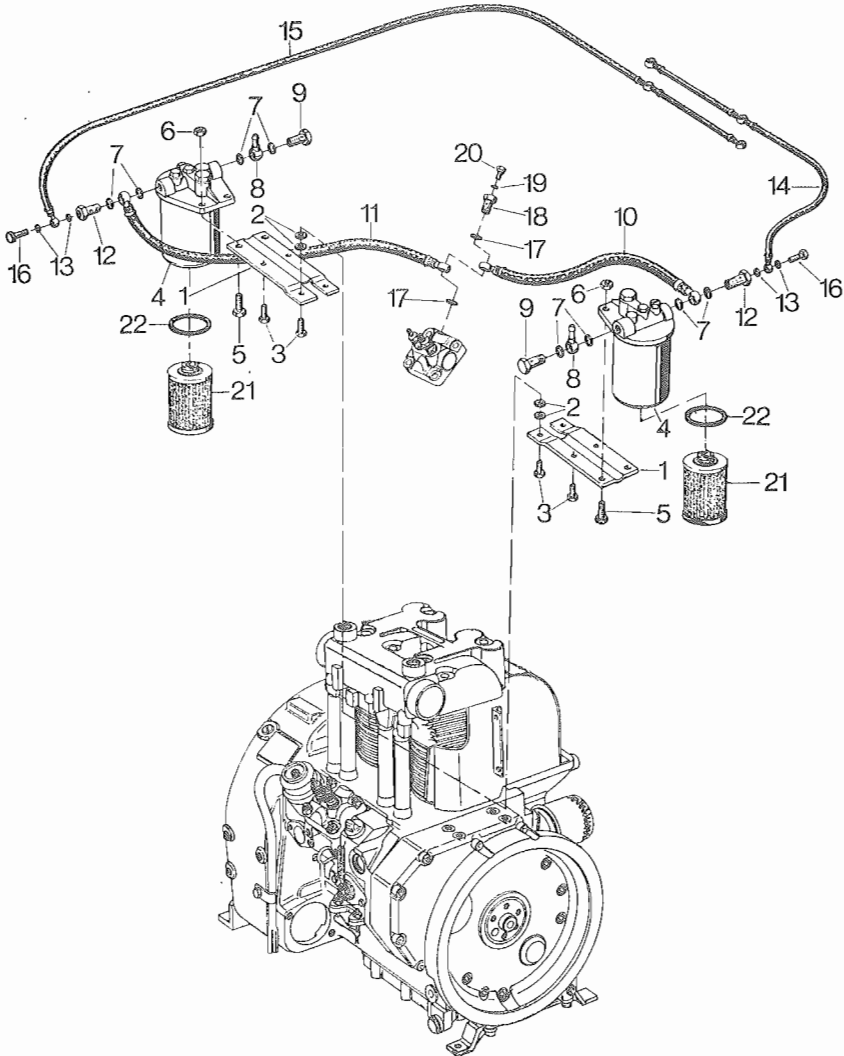

Fig. No.	Bestell-Nr. Ordering No.. No. référence No. de pedido	Stück Quantity Quantités Cantidades			Hinweise Hints Indications Indicaciones	
		Z 788	Z 789	Z 790		
1	032 754 00	1	1	1		
2	501 481 00	4	4	4	8,4	DIN 125-St A3C
3	500 268 00	4	4	4	M 8 x 20	DIN 933 - 8.8
4	400 674 00	1	1	1		
5	500 292 00	2	2	2	M 10 x 25	DIN 933 - 8.8
6	500 235 00	2	2	2	M 10	DIN 934 - 8
7	500 012 00 D2	4	4	—	A 14 x 18	DIN 7603 - Cu
8	500 159 00	1	1	—		
9	500 064 00	1	1	—	A 8	DIN 7623
10	032 804 00	1	1	—	470 mm	
11	032 626 01	1	1	—	315 mm	
12	032 807 00	1	1	—		
13	500 009 00 D7	2	2	—	A 8 x 11,5	DIN 7603 - Cu
14	034 097 00	1	1	—	458 mm	
15	034 096 00	1	1	—	558 mm	
16	500 061 00	1	1	—	A 2/3	DIN 7623
17	500 011 00 D2	2	2	—	A 12 x 15,5	DIN 7603 - Cu
18	036 135 00	1	1	—		
19	500 008 00	1	1	—	A 6,5 x 9,5	DIN 7603 - Cu
20	036 136 00	1	1	—		
21	400 073 00 W2	1	1	1		
22	490 365 00 P1	1	1	1		

Förderpumpe, Leitungen

Fuel feed pump, pipes

A01

Pompe d'alimentation, conduites

Bomba de alimentación, tubería

Pompa A. C., mangueras

Tafel Nr.

Tabl. No.

Tavola N.

12

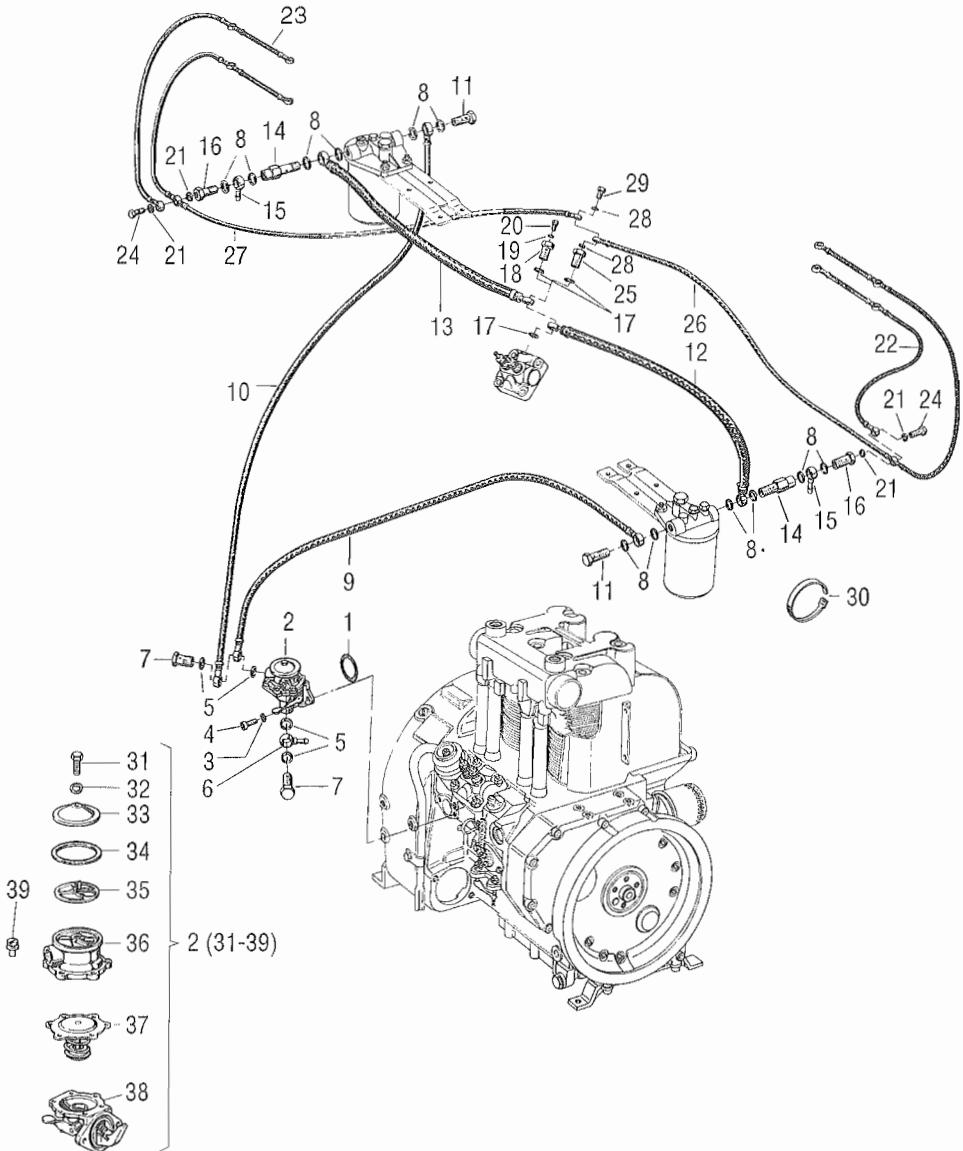

Fig. No.	Bestell-Nr. Ordering No. No. référence No. de pedido	Stück Quantity Quantités Cantidades			Hinweise Hints Indications Indicaciones	
		Z 788	Z 789	Z 790		
1	501 299 00	1	1	1		
2	400 374 00	1	1	1		
3	500 812 00	2	2	2	A 6	DIN 137
4	500 507 00	2	2	2	M 6 x 16	DIN 912 - 8.8
5	500 012 00 W4	4	4	4	A 14 x 18	DIN 7603 - Cu
6	500 159 00	1	1	1		
7	500 064 00	2	2	2	A 8	DIN 7623
8	500 012 00 D2	6	6	6	A 14 x 18	DIN 7603 - Cu
9	032 755 00	1	1	1	550 mm	
10	032 756 00	1	1	1	345 mm	
11	500 064 00	1	1	1	A 8	DIN 7623
12	032 804 00	1	1	1	470 mm	
13	031 516 00	1	1	1	365 mm	
14	034 977 00	1	1	1		
15	500 159 00	1	1	1		
16	032 807 00	1	1	1		
17	500 011 00 D2	2	2	2	A 12 x 15,5	DIN 7603 - Cu
18	036 135 00	1	1	1		
19	500 008 00	1	1	1	A 6,5 x 9,5	DIN 7603 - Cu
20	036 136 00	1	1	1		
21	500 009 00 D7	2	2	2	A 8 x 11,5	DIN 7603 - Cu
22	034 097 00	1	1	1	458 mm	
23	034 096 00	1	1	1	558 mm	
24	500 061 00	1	1	1	A 2/3	DIN 7623
25	034 077 00	1	1	1		
26	034 099 00	1	1	1	998 mm	
27	034 098 00	1	1	1	1098 mm	
28	500 009 00 D7	2	2	2	A 8 x 11,5	DIN 7603 - Cu
29	500 061 00	1	1	—	A 2/3	DIN 7623 Zn
29	037 479 00	—	—	1		
30	400 927 00	1	1	1		
31	—	—	—	—		
32	490 185 00	1	1	1		
33	—	—	—	—		
34	490 184 00	1	1	1		
35	490 183 00	1	1	1		
36	—	—	—	—		
37	490 182 00	1	1	1		
38	—	—	—	—		
39	490 181 00	1	1	1		

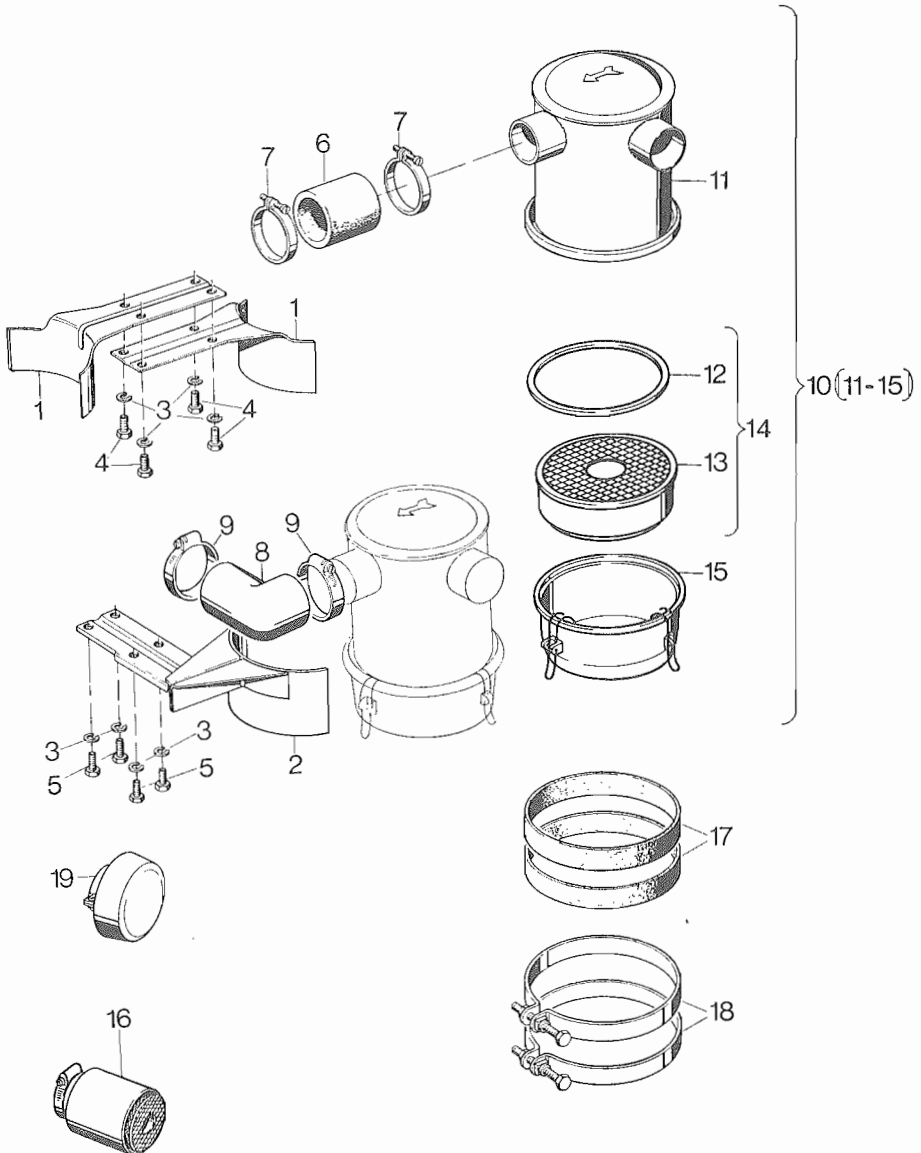

Fig. No.	Bestell-Nr.	Stück			Hinweise	
	Ordering No.	Quantity	Quantity	Quantity	Hints	
	No. référence	Quantités	Quantités	Quantités	Indications	
	No. de pedido	Cantidades	Cantidades	Cantidades	Indicaciones	
		Z 788	Z 789	Z 790		
1	031 256 00	1	1	1		
2	004 179 00	1	1	1		
3	500 028 00	4	4	4	8	DIN 128
4	500 268 00	4	4	4	M 8 x 20	DIN 933-8.8
5	500 519 00	4	4	4	M 8 x 20	DIN 912-8.8
6	032 173 00	1	1	1		
7	400 955 00	2	2	2		
8	032 751 00	1	1	1		
9	400 955 00	2	2	2		
10	400 688 10	1	1	1		
11	—	—	—	—		
12	490 213 00 P1	1	1	1		
13	—	—	—	—		
14	490 351 00	1	1	1		
15	490 209 00	1	1	1		
16	400 421 10	1	1	1		
17	032 176 00	2	2	2		
18	400 372 00	2	2	2		
19	400 712 10	1	1	1		

Auspuffrohr, Auspufftopf
 Exhaust manifold, exhaust silencer
 Tube d'échappement, silencieux
 Tubo de escape, silenciador

Tafel Nr.
 Tabl. No.

14

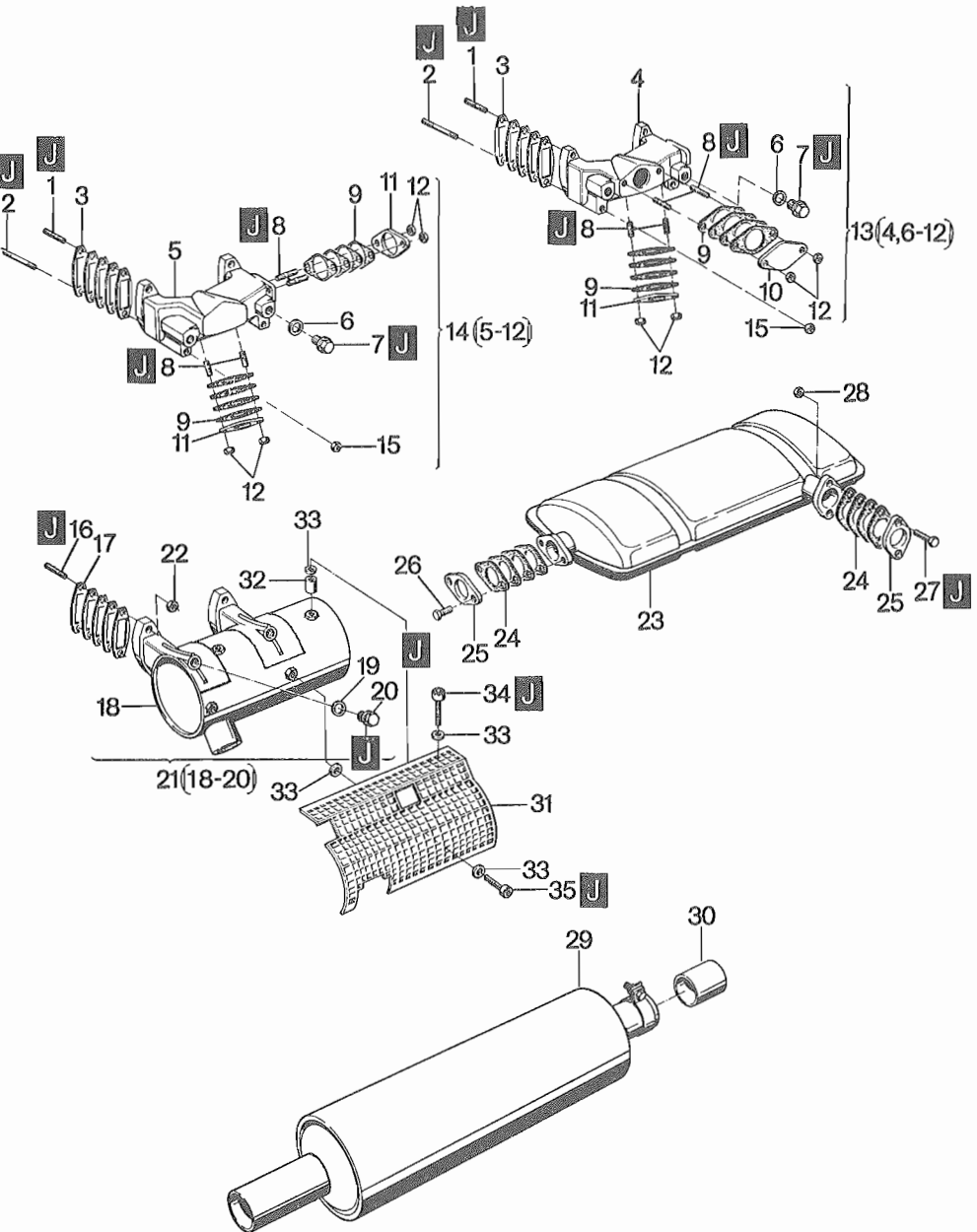

Fig. No.	Bestell-Nr. Ordering No. No. référence No. de pedido	Stück Quantity Quantités Cantidades			Hinweise Hints Indications Indicaciones
		Z 788	Z 789	Z 790	
1	500 379 00	2	2	2	M 8 x 25 DIN 835 - 5.6
2	500 394 00	2	2	2	M 8 x 105 DIN 835 - 5.6
3	012 859 01 d1	1	1	1	
4	—	—	—	—	
5	—	—	—	—	
6	032 288 00	2	2	2	
7	500 447 00	2	2	2	R 1/4 DIN 910
8	500 373 00	4	4	4	M 8 x 18 DIN 835 - 10.9
9	012 860 00 d1	1	1	1	
10	032 633 00	1	1	1	
11	033 242 00	1	1	1	
12	500 230 00	4	4	4	M 8 Ms DIN 934 - Ms
13	005 687 00	1	1	1	
14	006 045 00	1	1	1	
15	400 816 00	4	4	4	
16	500 379 00	4	4	4	M 8 x 25 DIN 835 - 5.6
17	012 859 01 d1	1	1	1	
18	—	—	—	—	
19	032 288 00	2	2	2	
20	500 447 00	2	2	2	R 1/4 DIN 910
21	005 851 01	1	1	1	
22	400 816 00	4	4	4	
23	008 618 00	1	1	1	
24	012 860 00 d1	1	1	1	
25	033 242 00	2	2	2	
26	500 268 00	2	2	2	M 8 x 20 DIN 933 - 8.8
27	500 270 00	2	2	2	M 8 x 25 DIN 933 - 8.8
28	500 230 00	2	2	2	M 8 Ms DIN 934 - Ms
29	008 709 00	1	1	1	
30	030 479 01	1	1	1	
31	037 213 00	1	1	1	
32	035 206 00	2	2	2	
33	500 168 00	8	8	8	8,4 DIN 125 Ms
34	501 759 00	2	2	2	M 8 x 30 DIN 912-8.8 Zn
35	501 731 00	2	2	2	M 8 x 10 DIN 912-8.8 Zn

Andrehvorrichtung schs.
 Starting device
 Dispositif demarrage
 Dispositivo de arranque

Tafel Nr.
 Tabl. No.

A 04

15

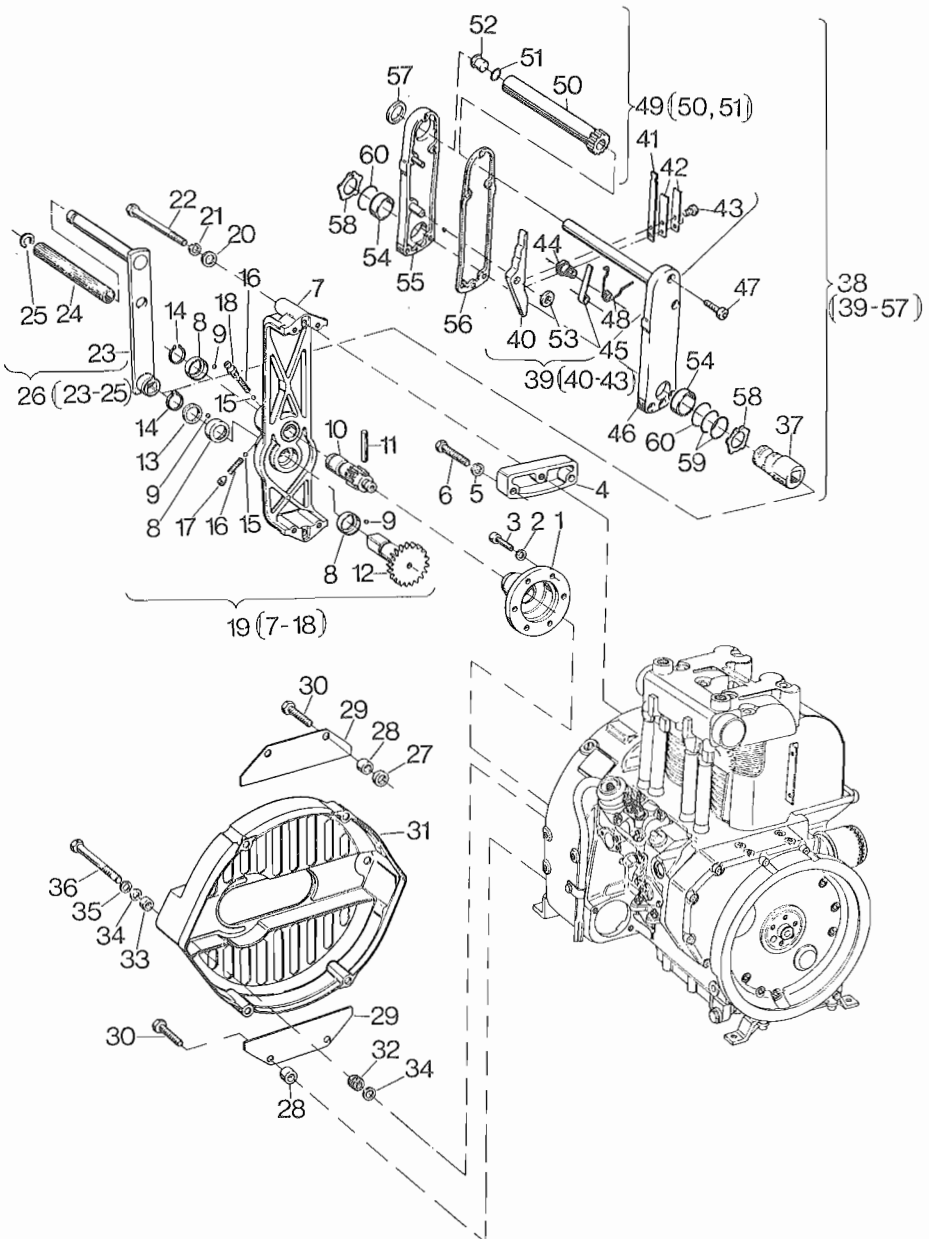

Fig. No.	Bestell-Nr. Ordering No. No. référence No. de pedido	Stück Quantity Quantités Cantidades			Hinweise Hints Indications Indicaciones	
		Z 788	Z 789	Z 790		
1	032 695 00	1	1	1		
2	500 028 00	6	6	6	8	DIN 128
3	500 521 00	6	6	6	M 8 x 25	DIN 912 - 8.8
4	032 692 01	2	2	2		
5	500 029 00	4	4	4	10	DIN 128
6	500 295 00	4	4	4	M 10 x 40	DIN 933 - 8.8
7	—	—	—	—		
8	031 753 01	3	3	3		
9	500 098 00	45	45	45	6 mm III	DIN 5401
10	033 000 00	1	1	1		
11	500 095 00	1	1	1	8 x 45	DIN 1475
12	032 999 00	1	1	1		
13	030 124 01	1	1	1		
14	500 204 00	2	2	2	24 x 1,2	DIN 471
15	500 098 00	2	2	2	6 mm III	DIN 5401
16	031 591 00	2	2	2		
17	030 794 00	1	1	1		
18	500 078 00	1	1	1	AM 8 x 1	DIN 71412
19	005 265 00	1	1	1		
20	501 459 00	2	2	2	B 10,5	DIN 125-St A3C
21	500 029 00	2	2	2	10	DIN 128
22	500 304 00	2	2	2	M 10 x 90	DIN 931 - 8.8
23	—	—	—	—		
24	035 224 00	1	1	1		
25	035 154 00	1	1	1		
26	003 030 02	1	1	1		
27	500 171 00	2	2	2	B 11,5	DIN 7989
28	033 543 00	4	4	4		
29	035 201 00	2	2	2		
30	500 296 00	4	4	4	M 10 x 45	DIN 933 - 8.8
31	035 137 00	1	1	1		
32	036 652 00	6	6	6		
33	035 147 00	2	2	2		
34	501 459 00	4	4	4	B 10,5	DIN 125-St A3C
35	500 029 00	2	2	2	10	DIN 128
36	500 305 00	2	2	2	M 10 x 100	DIN 931 - 8.8

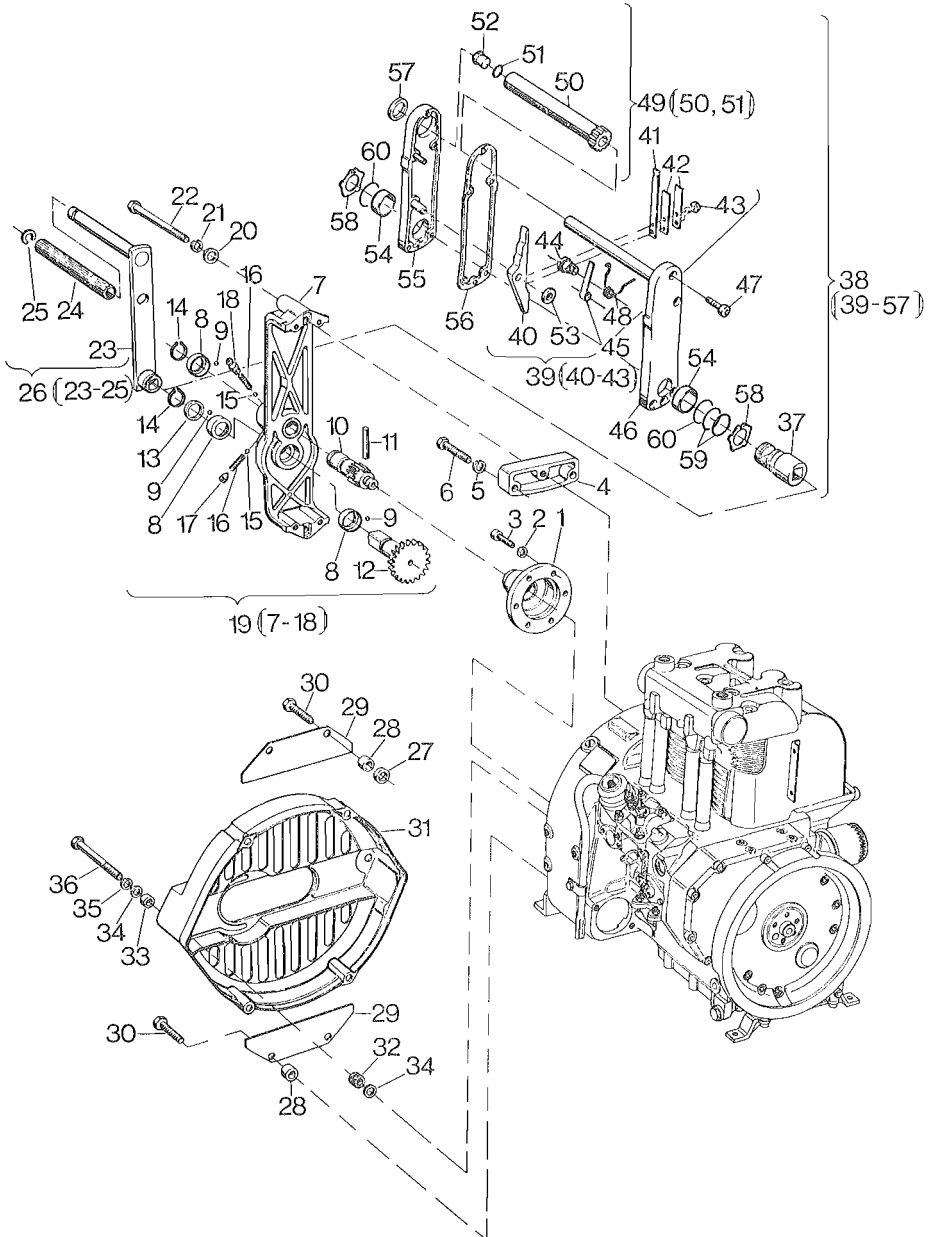

Fig. No.	Bestell-Nr. Ordering No. No. référence No. de pedido	Stück Quantity Quantités Cantidades			Hinweise Hints Indications Indicaciones	
		Z 788	Z 789	Z 790		
37	010 189 00	1	1	1		
38	010 278 05	1	1	1		„A“
39	010 114 04	1	1	1		
40	—	—	—	—		
41	038 121 02	1	1	1		
42	039 171 00	2	2	2		
43	503 165 00	2	2	2	M 5 x 8	DIN 6912-8.8
44	039 556 00	1	1	1		
45	039 549 00	1	1	1		
46	—	—	—	—		
47	501 944 00	5	5	5	M 6 x 25	DIN 6912-8.8Zn
48	039 559 00	1	1	1	„A“	
49	010 113 10	1	1	1		
50	—	—	—	—		
51	501 691 00	1	1	1	19 x 1,8	
52	501 992 00	1	1	1	V 18	
53	501 958 00	1	1	1	10 x 16 x 0,5	DIN 988
54	501 934 00	2	2	2		
55	—	—	—	—		
56	038 130 00	1	1	1		
57	501 942 00	1	1	1	28 x 35 x 4	
58	501 943 00	2	2	2	A 30 x 1,5	DIN 983
59	502 585 00	2	2	2	26 x 1,5	
60	039 286 00	0...4	0...4	0...4		0,15 mm

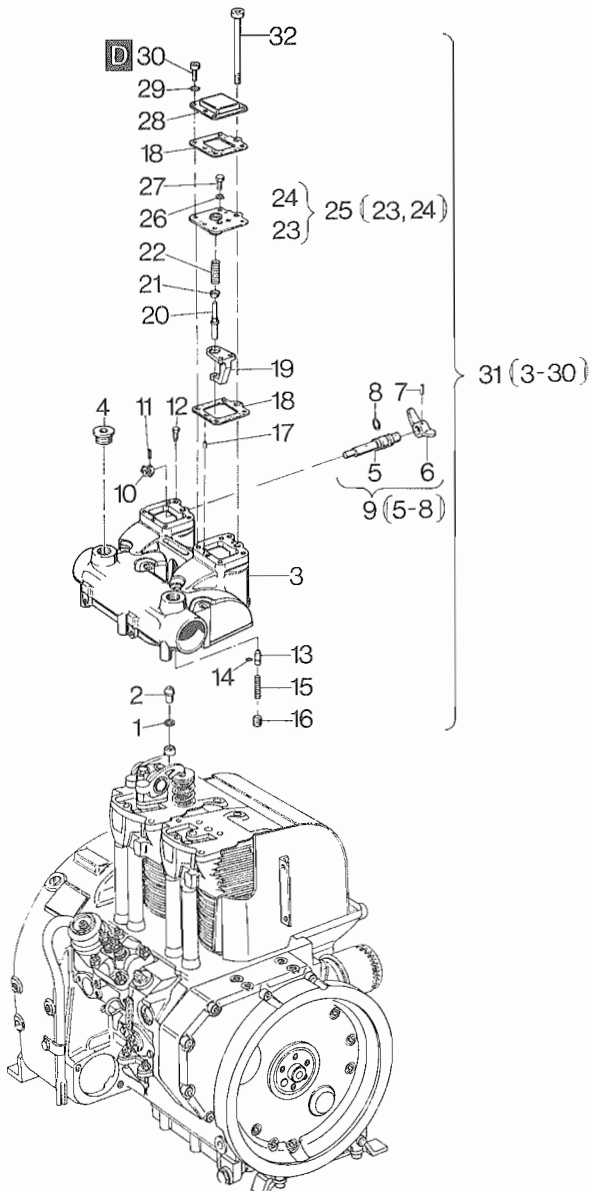

Fig. No.	Bestell-Nr. Ordering No. No. référence No. de pedido	Stück Quantity Quantités Cantidades			Hinweise Hints Indications Indicaciones	
		Z 788	Z 789	Z 790		
1	501 232 00	2	2	2	5 x 10 x 0,5	DIN988ST1K00
2	034 519 00	2	2	2		
3	—	—	—	—		
4	500 863 00	2	2	2	M 20 x 1,5	DIN 908
5	—	—	—	—		
6	031 734 01	2	2	2		
7	500 346 00	2	2	2	4 x 18	DIN 1481
8	400 227 00 D1	2	2	2	13,3 x 2,4	
9	005 268 01	2	2	2		
10	030 514 00	2	2	2		
11	500 341 00	2	2	2	3 x 16	DIN 1481
12	500 649 00	2	2	2	AM 6 x 16	DIN 561 - 8.8
13	032 994 00	2	2	2		
14	501 542 00	2	2	2	5 x 1	
15	031 728 01	2	2	2		
16	500 650 00	2	2	2	AM 10 x 10	DIN 913
17	500 339 00	4	4	4	3 x 8	DIN 1481
18	033 344 01	4	4	4		
19	030 463 00	2	2	2		
20	033 343 01	2	2	2		
21	030 450 01	2	2	2		
22	031 887 00	2	2	2		
23	—	—	—	—		
24	—	—	—	—		
25	005 267 02	2	2	2		
26	500 027 00	4	4	4	6	DIN 128
27	500 254 00	4	4	4	M 6 x 10	DIN 933 - 8.8
28	032 993 01	2	2	2		
29	500 027 00	10	10	10	6	DIN 128
30	500 508 00	10	10	10	M 6 x 18	DIN 912 - 8.8
31	006 107 10	1	1	1		
32	500 648 00	2	2	2	M 8 x 120	DIN 912 - 8.8

Starter, Generator
Starter, alternator
A 05 Démarreur, alternateur
Arrancador, alternador

Tafel Nr.
Tabl. No.

17

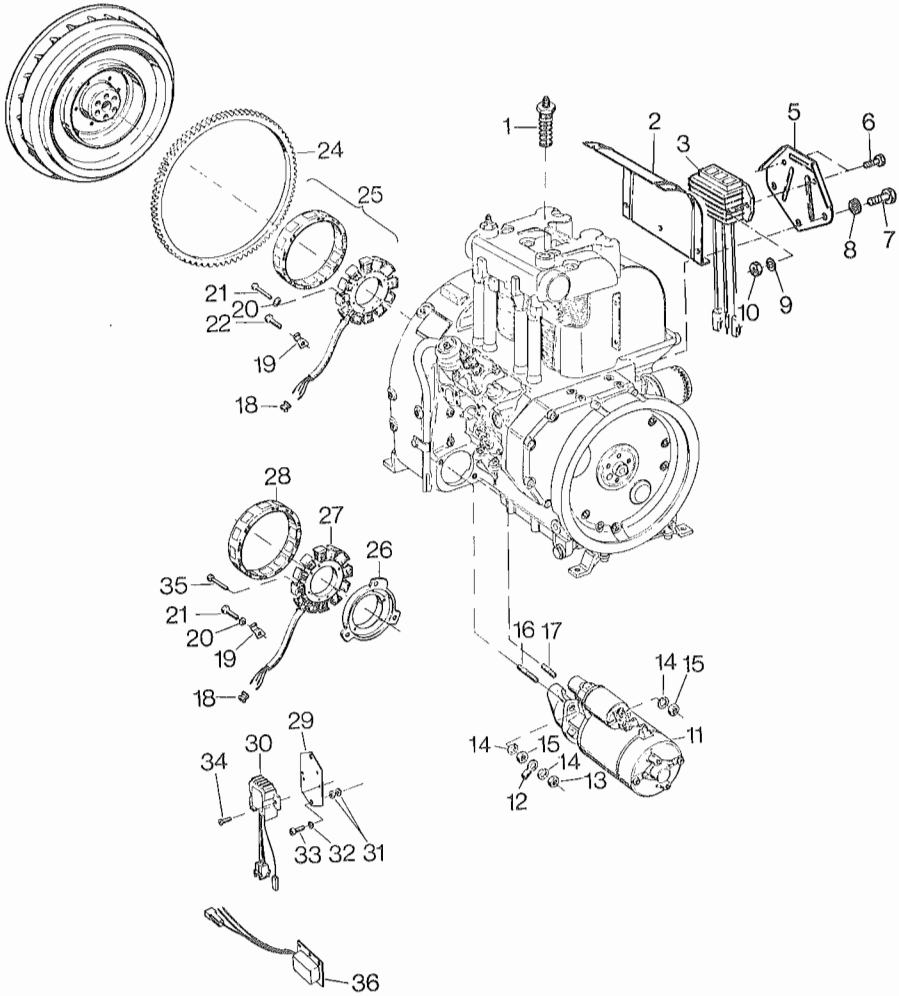

Fig. No.	Bestell-Nr. Ordering No. No. référence No. de pedido	Stück Quantity Quantités Cantidades			Hinweise Hints Indications Indicaciones	
		Z 788	Z 789	Z 790		
1	400 685 00	1	1	1		
2	039 013 00	1	1	1		
3	502 838 11	1	1	1		
4	---	---	---	---		
5	038 975 00	1	1	1		
6	501 706 00	2	2	2	M 6 x 20	DIN 912-8.8 A3C
7	501 357 00	3	3	3	M 10 x 16	DIN 912-8.8 A3C
8	501 356 00	3	3	3	10	DIN 128
9	501 445 00	3	3	3	6,4	DIN 125-St A3C
10	400 283 00	2	2	2	M 6	SSN 440-8 Cu
11	400 008 10	1	1	1	12 V - 1,9 kW	
12	500 634 00	1	1	1		
13	500 635 00	1	1	1	M 12 A3C	DIN 936-17H
14	500 632 00	3	3	3	12	DIN 128-A3C
15	500 936 00	2	2	2	M 12	DIN 934-8 A3C
16	032 868 00	1	1	1		
17	500 423 00	1	1	1	M 12 x 25	DIN 939-5.6
18	400 431 00	1	1	1		
19	031 426 01	1	1	1		
20	400 277 00	3	3	3	6	
21	500 507 00	3	3	3	M 6 x 16	DIN 912-8.8
22	501 771 00	1	1	1	M 6 x 16	DIN 933-8.8 A3C
23	---	---	---	---		
24	032 172 01	1	1	1		
25	502 836 10	1	1	1	Ducati	
26	035 134 00	1	1	1	Syncro	
27	400 983 01	1	1	1	Syncro	
28	035 438 00	1	1	1	Syncro	
29	035 141 01	1	1	1	Syncro	
30	400 985 01	1	1	1	Syncro	
31	501 445 00	4	4	4	6,4	DIN 125-St A3C
32	500 027 00	2	2	2	6	DIN 128
33	500 507 00	2	2	2	M 6 x 16	DIN 912-8.8
34	500 492 00	2	2	2	M 4 x 10	DIN 84-4.8 A3C
35	501 348 00	4	4	4	M 4 x 25	DIN 933-8.8
36	400 986 01	1	1	1	Syncro	

1(2-18,20,23-37)

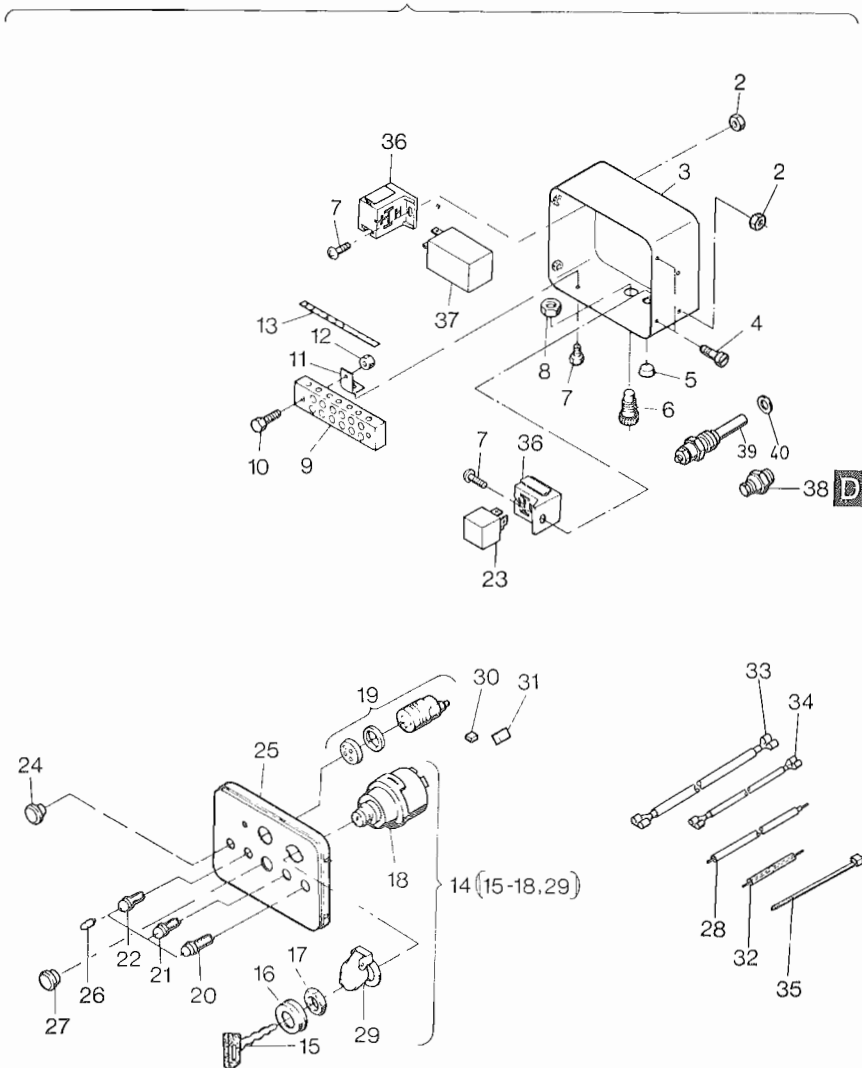

Fig. No.	Bestell-Nr. Ordering No. No. référence No. de pedido	Stück Quantity Quantités Cantidades			Hinweise Hints Indications Indicaciones	
		Z 788	Z 789	Z 790		
1	011 129 02	1	1	1	12 V	
2	400 282 00	3	3	3		
3	007 163 11	1	1	1		
4	502 892 00	4	4	4	M 6 x 12	DIN 8.8 A3D
5	501 608 00	2	2	2		
6	501 590 10	1	1	1		
7	500 493 00	5	5	5	M 5 x 10	DIN 7985-4.8 A3R
8	501 591 00	1	1	1		
9	501 607 00	1	1	1		
10	501 588 00	2	2	2	M 4 x 20	DIN 84-4.8 A3C
11	036 667 00	2	2	2		
12	501 471 00	2	2	2	M 4	DIN 934-8 A3C
13	050 043 00	1	1	1		
14	502 765 02	1	1	1		
15	503 453 00 P1	1	1	1		
16	—	—	—	—		
17	—	—	—	—		
18	—	—	—	—		
19	400 686 00	1	1	1		
20	501 765 00	1	1	1	BATT	
21	501 766 00	1	1	1	OIL	
22	501 764 00	1	1	1	TEMP.	
23	502 777 01	2	2	2		
24	400 960 00	3	3	3	F 17	
25	035 092 11	1	1	1		
26	400 097 00	3	3	3	12 V 2 W	
27	400 914 00	2	2	2	F 24	
28	011 501 01	1	1	1		
29	490 509 00	1	1	1		
30	502 766 00	1	1	1	4 - P	
31	502 767 00	1	1	1	6 - P	
32	010 902 01	1	1	1		
33	010 898 01	1	1	1		
34	010 899 01	1	1	1		
35	503 584 00	1	1	1		
36	502 760 00	3	3	3		
37	502 758 01	1	1	1	12 V HATZ	MSR
38	400 213 00	1	1	1	OIL	
39	501 524 00	1	1	1	TEMP.	
40	500 624 00	2	2	2	A 10 x 13,5	DIN 7603-Cu

Öleinfüllung, Ölablaßrohr

Oil filling, oil drain tube

Tafel Nr.

Tabl. No.

A 07

Remplissage huile, tube de vidange

Tubuladura, tubo de purga

19

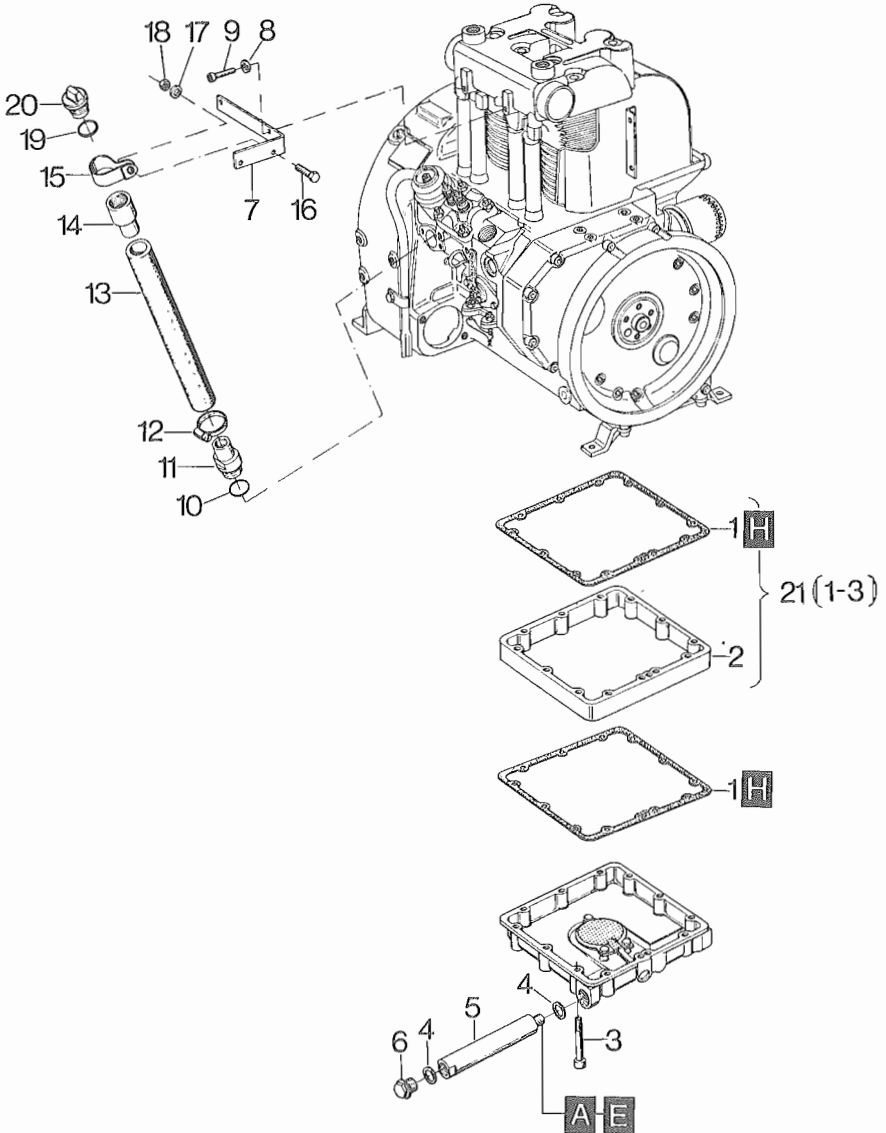

Fig. No.	Bestell-Nr. Ordering No. No. référence No. de pedido	Stück Quantity Quantités Cantidades			Hinweise Hints Indications Indicaciones	
		Z 788	Z 789	Z 790		
1	032 121 00	2	2	2		
2	—	—	—	—		
3	500 531 00	12	12	12	M 8 x 75	DIN 912 - 8.8
4	500 016 00	2	2	2	A 22 x 27	DIN 7603 - Cu
5	033 816 00	1	1	1		
6	500 444 00	1	1	1	CM 22 x 1,5	DIN 7604
7	034 729 00	1	1	1		
8	501 200 00	2	2	2	A 6,4	DIN 9021 - St Zn
9	500 509 00	2	2	2	M 6 x 20	DIN 912 - 8.8
10	501 538 00	1	1	1	23 x 3	
11	034 731 00	1	1	1		
12	400 865 00	1	1	1		
13	400 866 00	1	1	1		
14	034 730 00	1	1	1		
15	400 864 00	1	1	1		
16	500 267 00	1	1	1	M 8 x 16	DIN 933 - 8.8
17	501 481 00	1	1	1	8,4	DIN 125-St A3C
18	500 229 00	1	1	1	M 8	DIN 934 - 8
19	501 538 00	1	1	1	23 x 3	
20	030 690 03	1	1	1		
21	006 878 00	1	1	1		

Absperrventil
Shut off valve
Soupape d'arrêt
Valvula de parada

Tafel Nr.
Tabl. No.

A 10

20

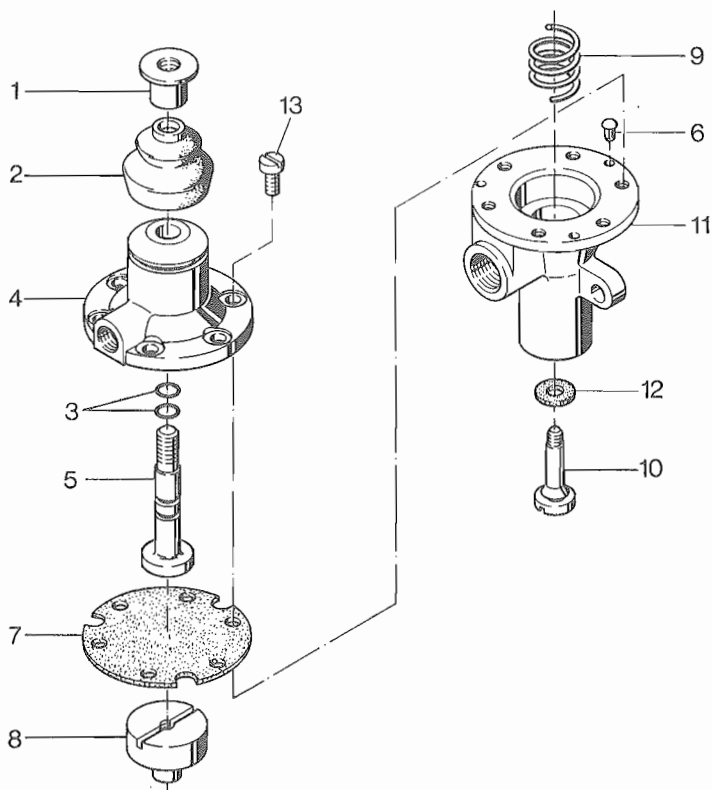

Fig. No.	Bestell-Nr. Ordering No. No. référence No. de pedido	Stück Quantity Quantités Cantidades			Hinweise Hints Indications Indicaciones	
		Z 788	Z 789	Z 790		
1	035 359 00	1	1	1		
2	502 489 00	1	1	1		
3	501 670 00	2	2	2		
4	036 922 00	1	1	1		
5	036 920 00	1	1	1		
6	—	—	—	—		
7	036 921 00	1	1	1		
8	036 918 00	1	1	1		
9	036 914 00	1	1	1		
10	036 912 00	1	1	1		
11	036 923 00	1	1	1		
12	036 913 00	1	1	1		
13	500 492 00	6	6	6	M 4 x 10	DIN 84-4.8 A3C

Wellenstummel, elast. Kupplung
Stubshaft, flexible coupling
A 16 Bout d'arbre, accouplement elastique
Eje, acoplamiento elastico

Tafel Nr.
Tabl. No.

21

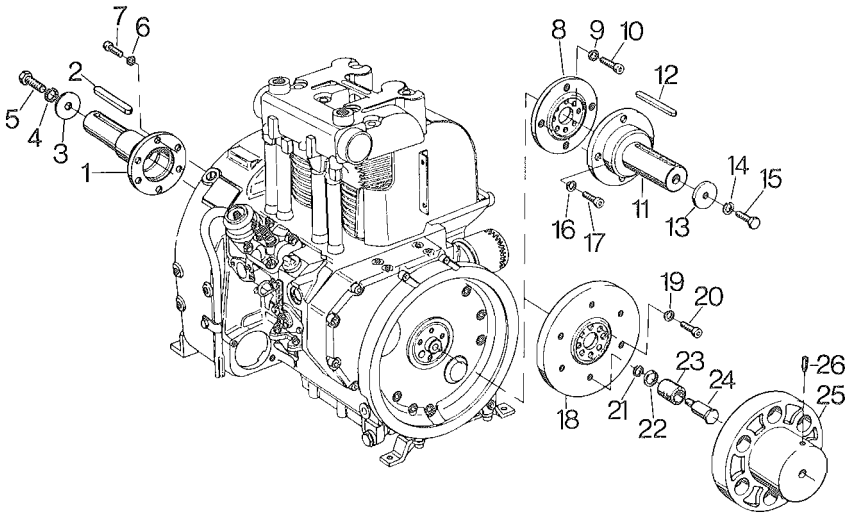

Fig. No.	Bestell-Nr. Ordering No. No. référence No. de pedido	Stück Quantity Quantités Cantidades			Hinweise Hints Indications Indicaciones
		Z 788	Z 789	Z 790	
1	033 600 00	1	1	1	
2	500 814 00	1	1	1	A 12 x 8 x 100 DIN 6885
3	032 867 00	1	1	1	
4	500 030 00	1	1	1	12 DIN 128
5	500 312 00	1	1	1	M 12 x 30 DIN 933 - 8.8
6	500 028 00	6	6	6	8 DIN 128
7	500 521 00	6	6	6	M 8 x 25 DIN 912 - 8.8
8	032 823 00	1	1	1	
9	500 029 00	8	8	8	10 DIN 128
10	500 538 00	8	8	8	M 10 x 25 DIN 912 - 8.8
11	032 822 00	1	1	1	
12	500 626 00	1	1	1	A 14 x 9 x 100 DIN 6885
13	032 867 00	1	1	1	
14	500 030 00	1	1	1	12 DIN 128
15	500 312 00	1	1	1	M 12 x 30 DIN 933 - 8.8
16	500 029 00	4	4	4	10 DIN 128
17	500 538 00	4	4	4	M 10 x 25 DIN 912 - 8.8
18	031 150 00	1	1	1	
19	500 029 00	8	8	8	10 DIN 128
20	500 538 00	8	8	8	M 10 x 25 DIN 912 - 8.8
21	500 616 00	6	6	6	12 DIN 7980
22	030 790 00	6	6	6	
23	031 510 00	6	6	6	
24	030 469 00	6	6	6	
25	030 405 00	1	1	1	
26	500 046 00	1	1	1	AM 8 x 15 DIN 916 - 10.9

Fig. No.	Bestell-Nr.	Stück			Hinweise	
	Ordering No.	Quantity	Quantités	Cantidades	Hints	Indications
	No. référence				Indicaciones	
	No. de pedido		Z 788	Z 789	Z 790	
1	500 584 00	2	2	2	8 m 6 x 20	DIN 7 - 9S20k
2	032 704 00	1	1	1		
3	032 339 00	1	1	1		
4	032 338 00	1	1	1		
5	032 703 00	1	1	1		
6	500 029 00	2	2	2	10	DIN 128
7	500 547 00	2	2	2	M 8 x 75	DIN 912 - 8.8
8	500 531 00	2	2	2	M 10 x 45	DIN 912 - 8.8
9	500 597 00	2	2	2	M 8 x 100	DIN 912 - 8.8
10	500 595 00	1	1	1	M 30 x 1,5	DIN 906
11	500 584 00	2	2	2	8 m 6 x 20	DIN 7 - 9S20k
12	032 702 00	1	1	1		
13	031 143 00	1	1	1		
14	031 142 01	1	1	1		
15	500 520 00	6	6	6	M 8 x 20	DIN 7 - 9S30k
16	032 703 00	1	1	1		
17	500 546 00	2	2	2	M 10 x 40	DIN 912 - 8.8
18	500 584 00	2	2	2	8 m 6 x 20	DIN 7 - 9S20k
19	032 702 00	1	1	1		
20	034 943 00	1	1	1		
21	033 582 00	1	1	1		
22	500 520 00	6	6	6	M 8 x 20	DIN 6912 - 8.8
23	034 200 00	1	1	1		
24	500 520 00	4	4	4	M 8 x 20	DIN 6912 - 8.8
25	034 289 00	1	1	1		
26	500 029 00	6	6	6	10	DIN 128
27	500 292 00	6	6	6	M 10 x 25	DIN 933 - 8.8
28	034 288 01	1	1	1		
29	030 303 00	1	1	1		
30	501 481 00	4	4	4	8,4	DIN 125-St A3C
31	500 277 00	4	4	4	M 8 x 40	DIN 931 - 8.8
32	006 525 02	1	1	1		
33	500 616 00	1	1	1	12	DIN 7980
34	500 310 00	1	1	1	M 12 x 25	DIN 125-St A3C
35	501 459 00	4	4	4	B 10,5	DIN 125 - ST
36	035 436 00	1	1	1		
37	400 269 00	2	2	2		
38	400 888 00	1	1	1		
39	501 459 00	4	4	4	B 10,5	DIN 125-St A3C

Hydraulik Ölkühler, Anbauteile Hydr.-Pumpe

Oil cooler, mount. parts hydr. pump

Refroidisseur huile, pièce-mont. pompe hydr.

Radiador de aceite, piezas mont. bomba

Tafel Nr.

Tabl. No.

22

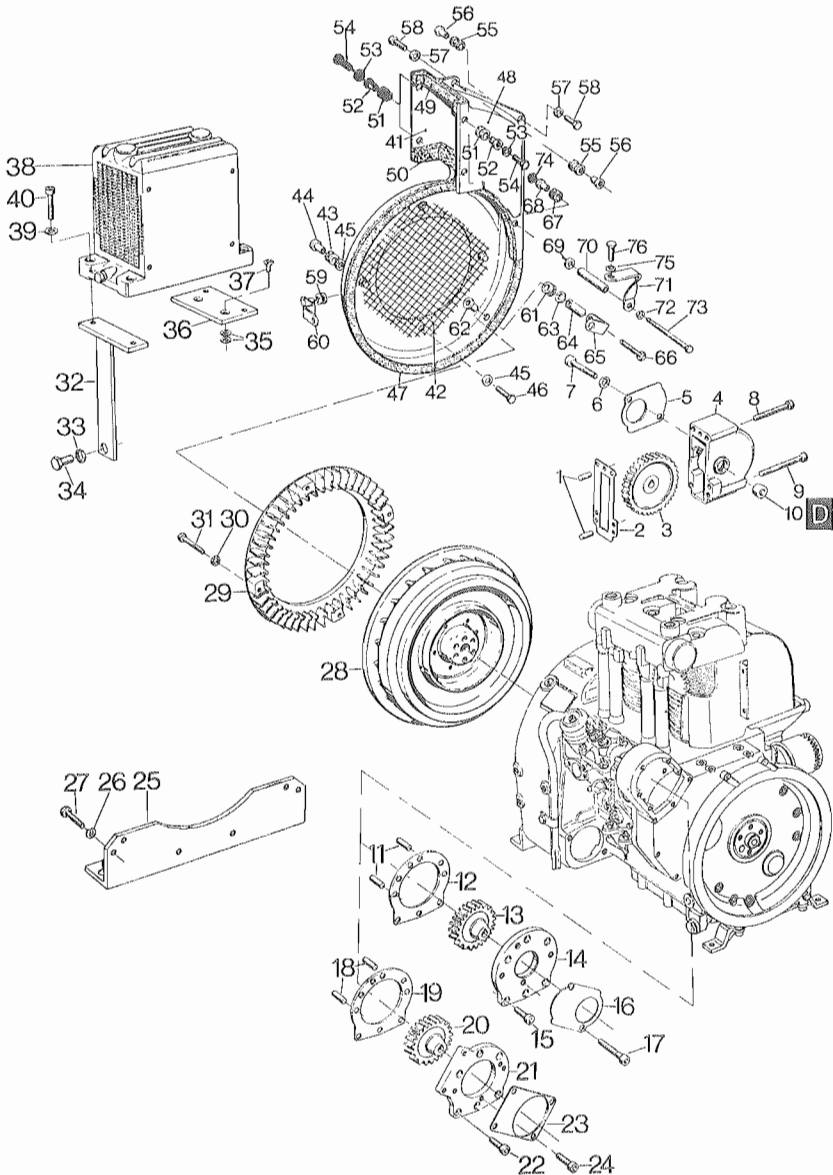

Fig. No.	Bestell-Nr. Ordering No. No. référence No. de pedido	Stück Quantity Quantités Cantidades			Hinweise Hints Indications Indicaciones
		Z 788	Z 789	Z 790	
40	500 546 00	4	4	4	M 10 x 40 DIN 912 - 8.8
41	035 143 00	1	1	1	
42	035 431 00	1	1	1	
43	036 652 00	4	4	4	
44	035 359 00	4	4	4	
45	501 143 00	8	8	8	6,4 DIN 7349
46	500 258 00	4	4	4	M 6 x 20 DIN 933 - 8.8
47	036 766 00	1	1	1	
48	035 148 00	1	1	1	
49	036 765 00	1	1	1	
50	035 764 00	1	1	1	
51	036 652 00	3	3	3	
52	035 283 00	3	3	3	
53	500 028 00	3	3	3	8 DIN 128
54	500 268 00	3	3	3	M 8 x 20 DIN 933 - 8.8
55	400 431 00	2	2	2	
56	035 359 00	2	2	2	
57	501 143 00	2	2	2	6,4 DIN 7349
58	500 257 00	2	2	2	M 6 x 16 DIN 933 - 8.8
59	036 652 00	1	1	1	
60	007 861 00	1	1	1	
61	036 652 00	1	1	1	
62	035 359 00	1	1	1	
63	501 143 00	1	1	1	6,4 DIN 7349
64	030 427 00	1	1	1	
65	035 434 00	1	1	1	
66	500 263 00	1	1	1	M 6 x 35 DIN 931 - 8.8
67	036 652 00	1	1	1	
68	033 776 00	1	1	1	
69	501 143 00	1	1	1	6,4 DIN 7349
70	036 628 00	1	1	1	
71	035 435 00	1	1	1	
72	500 027 00	1	1	1	6 DIN 128
73	501 551 00	1	1	1	M 6 x 75 DIN 931 - 8.8
74	500 227 00	1	1	1	M 6 DIN 934 - 8
75	500 029 00	1	1	1	10 DIN 128
76	500 290 00	1	1	1	M 10 x 16 DIN 933 - 8.8

Anhang für nicht abgebildete Zusatzausrüstung

Weitere Zusatzausrüstungen können aus Platzgründen in der Ersatzteilliste nicht mehr detailliert dargestellt werden. Für die Bestellung von Teilen aus nicht abgebildeten Zusatzausrüstungen verwenden Sie bitte nachfolgende Übersicht. Anhand der Skizze ist die gesuchte Zusatzausrüstung auffindbar, die für den jeweiligen Motortyp zugehörige Ident-Nr. der Ausrüstung ist aus der Tabelle ersichtlich. Ihre zuständige HATZ-Vertretung kann Ihnen anhand dieser Ident-Nr. das gewünschte Ersatzteil herausuchen.

Annex for additional equipment which is not illustrated

Due to lack of space we cannot list further additional equipment in our parts list. For parts ordering not illustrated, please use the below listed survey. With the aid of sketches you can find the required additional equipment. The ident-number belonging to the corresponding engine type can be taken from the table. Your HATZ agent is in a position to select for you the required spare part as soon as you have selected the correct ident-number.

Annexe concernant les accessoires complémentaires non-illustrés

Un certain nombre d'accessoires complémentaires n'ont pu, par suite d'un manque de place, être représentés d'une manière détaillée dans la liste de pièces détachées. Pour la commande de ces accessoires, qui ne sont pas illustrés, veuillez utiliser l'aperçu ci-après. A l'aide des croquis, il est possible de trouver l'accessoire souhaité, le No. ident. correspondant pour chaque type de moteur figure dans le tableau. Grâce à ce No. ident. votre représentant HATZ pourra vous trouver la pièce souhaitée.

En relación a equipos adicionales no ilustrados.

Debido a razones de espacio no es posible ilustrar otros equipos adicionales en la lista de piezas. Para pedidos de equipos adicionales no ilustrados favor usen la siguiente orientación. A base de las ilustraciones es posible encontrar el equipo adicional buscado, el número ident para el tipo de motor para el cual se necesita el equipo se puede obtener de la tabla.

El representante HATZ para su area puede entonces a base del número ident encontrar las piezas deseadas.

Zusatzausrüstungen

Equipements

Accessoires complémentaires

Equipos

Hinweise

Hints

Indications

Indications

	Code	Ident-Nr.	Z 788	Z 789	Z 790	
--	------	-----------	-------	-------	-------	--



A 10.70	008 867 00	X	X	X	
---------	------------	---	---	---	--

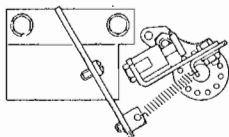

A 11.10 ✓	005 601 04	X	X	X	
-----------	------------	---	---	---	--

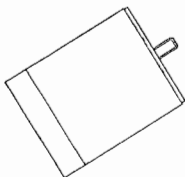

A 11.10	008 438 02	X	X	X	12 V
---------	------------	---	---	---	------

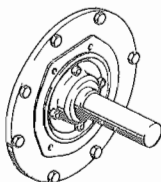

A 15.20	011 325 00	X	X	X	SAE B5
A 16.20	011 329 00	X	X	X	

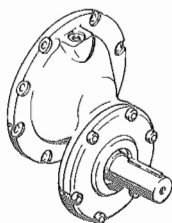

A 20.10	006 559 00	X	X	X	i = 2
---------	------------	---	---	---	-------

Zusatzausrüstungen

Equipements

Accessoires complémentaires

Equipos

Hinweise

Hints

Indications

Indications

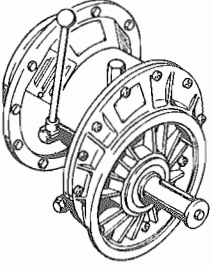
	Code	Ident-Nr.	Z 788	Z 789	Z 790	
	A 20.11	006 626 01	X	X	X	1.36 : 1
	A 20.11	006 615 01	X	X	X	i = 1,36
	A 20.11	006 625 01	X	X	X	i = 1,73
	A 21.11	006 634 01	X	X	X	i = 1,37 ld
	A 21.11	006 635 01	X	X	X	i = 1,75 ld
	A 21.11	006 627 01	X	X	X	i = 4.10 ld
	A 21.11	006 628 01	X	X	X	i = 5,19 ld

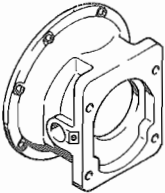

A 20.60	005 820 00	X	X	X	
---------	------------	---	---	---	--

Änderungsübersicht
Modification table
Aperçu de modifications
Tabla de modificaciones

Z 788

Bildtafel	Pos. Nr.	Bestell-Nr.	Stück	Bildtafel	Pos. Nr.	Bestell-Nr.	Stück	IMT NO.
Table	Fig. No.	Ordering No.	Qty.	Table	Fig. No.	Ordering No.	Qty.	
Planche	Fig. No.	No. référence	Qté.	Planche	Fig. No.	No. référence	Qté.	
Tabla	Fig. No.	No. de pedido	Cant.	Tabla	Fig. No.	No. de pedido	Cant.	

Z 788.14

Z 788.15

87.474

05	10	005 710 10	2 =	06	10	012 385 00	2	
05	10	005 711 10	2 =	06	10	012 387 00	2	
—	—	012 354 00	2 =	06	10	012 386 00	2	
05	13	006 391 01	2 =	06	13	006 391 02	2	
05	13	006 396 01	2 =	06	13	006 396 02	2	
—	—	012 351 00	2 =	06	13	012 351 01	2	
19	14	502 765 00	1 =	18	14	502 765 01	1	— — — —
19	15	501 664 00	1 ≠	18	15	503 453 00	1	— — — —

Änderungsübersicht
Modification table
Aperçu de modifications
Tabla de modificaciones

Z 789

Bildtafel	Pos. Nr.	Bestell-Nr.	Stück	Bildtafel	Pos. Nr.	Bestell-Nr.	Stück	IMT NO.
Table	Fig. No.	Ordering No.	Qty.	Table	Fig. No.	Ordering No.	Qty.	
Planche	Fig. No.	No. référence	Qté.	Planche	Fig. No.	No. référence	Qté.	
Tabla	Fig. No.	No. de pedido	Cant.	Tabla	Fig. No.	No. de pedido	Cant.	

Z 789.14

Z 789.15

87.474

05	10	005 710 10	2 =	06	10	012 385 00	2	
05	10	005 711 10	2 =	06	10	012 387 00	2	
—	—	012 354 00	2 =	06	10	012 386 00	2	
05	13	005 303 01	2 =	06	13	005 303 02	2	
05	13	005 678 01	2 =	06	13	005 678 02	2	
—	—	012 352 00	2 =	06	13	012 352 01	2	
19	14	502 765 00	1 =	18	14	502 765 01	1	— — — —
19	15	501 664 00	1 ≠	18	15	503 453 00	1	— — — —

Änderungsübersicht
Modification table
Aperçu de modifications
Tabla de modificaciones

Z 790

Bildtafel	Pos. Nr.	Bestell-Nr.	Stück	Bildtafel	Pos. Nr.	Bestell-Nr.	Stück	IMT NO.
Table	Fig. No.	Ordering No.	Qty.	Table	Fig. No.	Ordering No.	Qty.	
Planche	Fig. No.	No. référence	Qté.	Planche	Fig. No.	No. référence	Qté.	
Tabla	Fig. No.	No. de pedido	Cant.	Tabla	Fig. No.	No. de pedido	Cant.	

Z 790.14

Z 790.15

87.474

05	10	005 710 10	2 =	06	10	012 385 00	2	
05	10	005 711 10	2 =	06	10	012 387 00	2	
—	—	012 354 00	2 =	06	10	012 386 00	2	
05	13	005 303 01	2 =	06	13	005 303 02	2	
05	13	005 678 01	2 =	06	13	005 678 02	2	
—	—	012 352 00	2 =	06	13	012 352 01	2	
19	14	502 765 00	1 =	18	14	502 765 01	1	— — — —
19	15	501 664 00	1 ≠	18	15	503 453 00	1	— — — —

