



MOTORENFABRIK HATZ • D-94099 Ruhstorf • Germany
Tel.: 0 85 31 / 319-0 • Telex: 57260 • Telefax: 0 85 31 / 31 94 18
eMail: hatz.marketing@t-online.de • <http://www.hatz.com>

Original-Ersatzteile

Original-spare parts

Pièces de rechange d'origine

Repuestos originales

Pezzi di ricambio originali

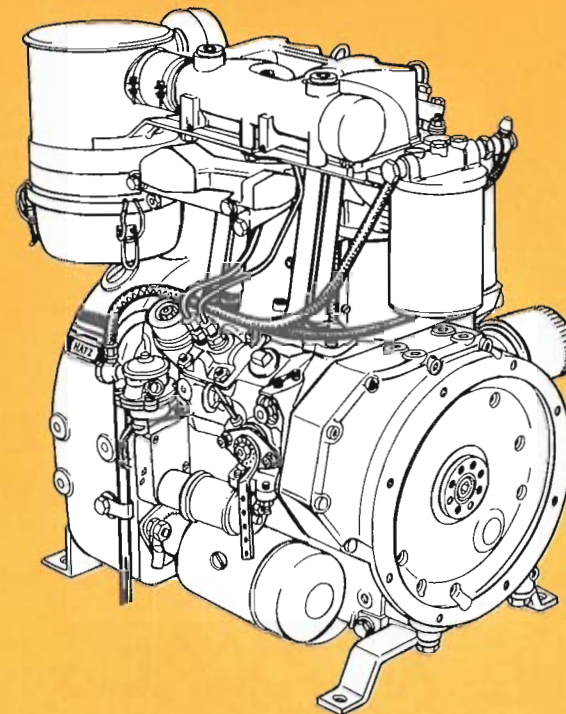

Z 788

Z 789

Z 790

434 700 02 - 10.98 - 2
Printed in Germany
DM 3.50

Bestellung für HATZ-Original-Ersatzteile

Order for HATZ Original spare parts

Commande de pièces d'origine HATZ

Pedido de repuestos originales HATZ

Ordine parti di ricambio originali HATZ

Besteller / Customer / Client / Cliente / Cliente

TYP

MOTOR/FABRIK NO.

MIN-1



Ersatzteilliste Nr./ Spare parts list no./ Liste des pièces de rechange no./ Lista de repuestos No./ Lista ricambi no.

Z 788 . 16



Z 789 . 16



Z 790 . 16



Stück / Qty / Q.tà	HATZ Ident No.	Stück / Qty / Q.tà	HATZ Ident No.

Versandart / Mode of dispatch / Mode d'expédition / Despacho deseado / Modo di spedizione

Post / Surface / Poste / Correo / Posta Luftfracht / airfreight / frêt aérien / flete aereo / Via aerea
Express / express / exprès / expreso / Espresso

Versandadresse / Consignee / Adresse destination / Dirección / Indirizzo di destinazione

Bestellung an: Order at: Commande à: Pedido a:

- die nächste HATZ-Servicestelle (siehe Servicestellenverzeichnis)
- your nearest HATZ service station (see service-list)
- votre station-service HATZ la plus proche (voir liste "Service")
- al servizio HATZ más cercano (ver cuaderno de Servicio)
- al più vicino centro di servizio HATZ (vedi lista centri autorizzati)

MOTORENFABRIK HATZ
D-94099 RUHSTORF

Tel: 0 85 31 / 319 - 0

Fax: 0 85 31 / 31 94 21

Inhaltsverzeichnis		Index	Tafel-N Table N
M ..	Grundmotor	Basic engine	
00	Ersatzteilsätze,	Spare parts kits,	01
34	Zubehör	accessories	02
01	Kurbelgehäuse	Crankcase	03
01, 10	Kurbelgehäuse, Ölpumpe	Crankcase, oil pump	04
02, 03	Kurbelwelle, Lagerflansch	Crankshaft, bearing flange	05
04	Nockenwelle, Regler	Camshaft, governor	
	Drehzahlverstellung	Speed control	06
05, 06	Kolben, Pleuel, Zylinder	Piston, conrod, cylinder	07
07	Zylinderkopf	Cylinder head	08
11	Steuergehäuse	Governor housing	09
12, 14	Startfüllung, Einspritzausrüstung,	Extra fuel device, injection equipment	10
17, 26	Schwungrad, Luftführung	Flywheel, air ducting	11
A ..	Zusatzausrüstung	Equipements	
01	Kraftstoffbehälter, Förderpumpe,	Fuel tank, fuel feed pump,	
	Filter, Leitungen	filter, pipes	12
01	Filter, Leitungen	filter, pipes	13
01	Förderpumpe, Leitungen	Fuel feed pump, pipes	14
02	Luftfilter	Air filter	15
03	Auspuffrohr, Auspufftopf	Exhaust manifold, exhaust silencer	16
04	Andrehvorrichtung schs.	Starting device	17
04	Dekompression	Decompression	18
05	Starter, Generator	Starter, alternator	19
05	Armaturenkasten	Instrument box	20
07	Öleinfüllung, Ölablaßrohr	Oil filling, oil drain tube	21
10	Absperrventil	Shut off valve	22
16	Wellenstummel, elast. Kupplung	Stubshaft, flexible coupling	23
18	Hydraulik Ölkühler,	Oil cooler,	
	Anbauteile Hydr.-Pumpe	mount. parts hydr. pump	24
	Weitere Zusatzausrüstungen	Further additional equipments	68 – 70
	Änderungsübersicht	Modification table	71

Sommaire

Indice

	Moteur de base	Motor de base	
00 34	Jeu de pièces de rechange, accessoires	Juegos de pieza de recambios, accesorios	01 02
01	Carter moteur	Caja cigueñal	03
01	Carter moteur, pompe à huile	Caja cigueñal, bomba de aceite	04
02, 03	Vilebrequin, palier	Cigüeñal, brida de cojinete	05
04	Arbre à cames, régulateur, réglage régime	Arbol de levas, regulador, ajuste de revoluciones	06
05, 06	Piston, bielle, cylindre	Embolo, biela, cilindro	07
07 – 09	Culasse	Culata	08
11	Carter distribution	Caja de mando	09
12, 14	Surcharge, equipem. d'injection	Sobre aliment-arranque, equipo de inyección,	10
17, 26	Volant, carter ventilation	Volante, conducción de aire	11

A .. Accessoires

Equipos

01	Réservoir à carburant, pompe d'alimentation, filtre, conduites	Depósito combustible, bomba de alimentación, filtro tubería	12
01	Filtre, conduites	Filtro tubería	13
01	Pompe d'alimentation, conduites	Bomba de alimentación, tubería	14
02	Filtre à air	Filtro de aire	15
03	Tube d'échappement, silencieux	Tubo de escape, silenciador	16
04	Dispositif démarrage	Dispositivo de arranque	17
04	Décompression	Decompresión	18
05	Démarrreur, alternateur	Arrancador, alternador	19
05	Boitier de bord	Cuadro de mando	20
07	Remp. huile, tube de vidange	Tubuladura, tubo de purga	21
10	Soupape d'arrêt	Valvula de parada	22
16	Bout d'arbre, âccouplement élast.	Eje, acoplamiento elastico	23
18	Refroidisseur huile, pièces montage pompe hydr.	Radiador de aceite, piezas mont. bomba	24

Page/Página No.

Modification des Nos de série	Tabla de modificaciones	68 – 70
Aperçu de modifications	Modificación de los Nos de serie	71

M .. Motore di base

00	Serie guarnizioni	01
34	kit accessori	02
01	Basamento motore	03
01, 10	Basamento motore, pompa olio	04
02, 03	Albero a gomito, supporto	05
04	Albero a camme, regolatore di giri	06
05, 06	Comando acceleratore	
	Pistone, biella, cilindro	07
07 – 09	Testa	08
11	Coperchio bilancieri	09
12, 14	Supplemento all'avviamento, Equipaggiamento di iniezione	10
17, 26	Volano, carter ventilatore	11

A .. Accessori

01	Serbatoio, pompa A.C., filtro gasolio, tubazione	12
01	filtro gasolio, tubazione	13
01	pompa A.C., tubazione	14
02	Filtro aria	15
03	Scarico, marmitta	16
04	Dispositivo de avviamento	17
04	Decompressione	18
05	Motorino avviamento, alternatore	19
05	Cruscotto	20
07	Bocchettone introduzione olio	
	Tubo scarico olio	21
10	Valvola di arresto	22
16	Contralbero, giunto elastico	23
18	Radiatore olio, particolari per montaggio pompa idraulica	24

Pagina

Predisposizioni 68 – 70

Modifica dei codici 71

M 00

Ersatzteilsätze
Spare parts kits
Jeux de pièces de rechange
Juegos de piezas de recambios
Serie guarnizioni

Tafel Nr.
Tabl.No.
Tavola N.

01

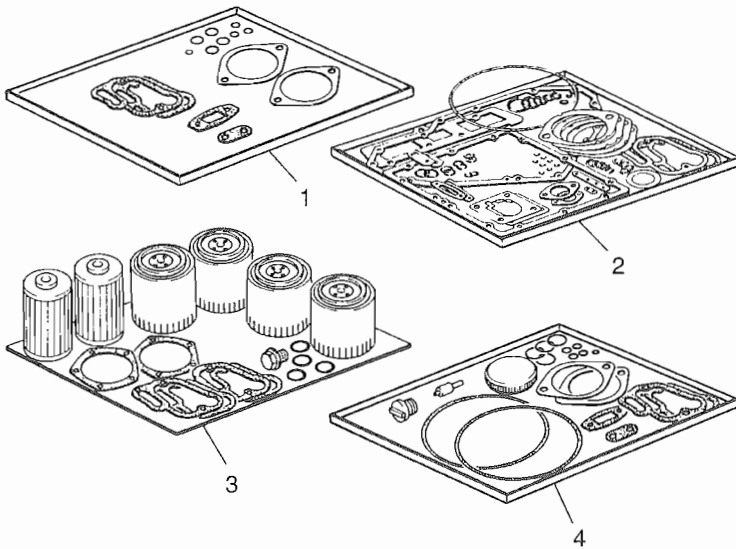

Fig.- No.	HATZ Ident-No.	Stück Qty.		P / W d / D	Bemerkungen Notes
		Z 788	Z 789	Z 790	
					<p>W: Im Wartungssatz enthalten. Incl. in maintenance kit. Contenu dans le jeu d'entretien. Incluido en el juego de mantenimiento. Contenuto nella serie manutenzione</p> <p>d: Im Dichtungssatz für 1 Zyl.-Kopf enthalten. Incl. in gasket set for 1 cylinder head. Contenu dans le jeu de joint p. 1 culasse. Incluido en el juego de juntas p. 1 culata. Contenuto nella serie guarnizioni p. 1 testa.</p> <p>P: Im Pannensatz enthalten. Incl. in emergency kit. Contenu dans le jeu secur. Incluido en el juego para averias. Contenuto nella serie di prima necessità.</p> <p>D: Im Dichtungssatz Kurbelgehäuse Incl. in gasket set crankcase. Contenu dans le jeu de joints carter moteur. Incluido en el juego de juntas caja cigüeñal. Contenuto nella serie guarnizioni basamento.</p> <p>1: Anzahl pro Satz - Qty. per kit Quantite par jeu Cantidad por juego. Quantità per serie.</p>
1	00569510	2	2	2	P1 Dichtungssatz für 1 Zylinderkopf Gasket set for 1 cyl. head Jeu de joint p. 1 culasse Juego de juntas para 1 culata. Serie guarnizioni per 1 testa.
2	01230200	1	1	1	Dichtungssatz für Kurbelgehäuse Gasket set for crankcase Jeu de joints p. carter moteur Juego de juntas para caja ciguenal. Serie guarnizioni basamento.
3	00961801	1	1	1	Wartungssatz für 1000 h 1000 hours maintenance kit Kit d'entretien 1000 heures - Juego de piezas para servicio 1000 horas. Kit di manutenzione a 1000 ore.
4	00966503	1	1	1	Pannensatz - Emergency kit Kit de secours - Juego para averias. Kit di prima necessità.

Fig.- No.	HATZ Ident-No.	Stück Qty.	P / W d / D	Bemerkungen Notes	
		Z 788	Z 789	Z 790	
1	00532400	1	1	1	Zubehörsatz - Accessoires kit Sort. accessoires Juego de accesorios Serie accessori
2	03631301	1	1	1	
3	03430612	1	1	1	

Dicht- und Klebstoffe Sealing- and bonding adhesives		Etanchéifiant et Colle Materias para empaquetar y pegar	
A = 502 230 01	Loctite Activator N	500 ml	} siehe Hinweis auf den einzelnen Bildtafeln as specified in the individual tables suivant les remarques sur les tableau correspondant según las indicaciones de las tablas correspondientes seguire le indicazioni sul quadro corrispondente
B = 502 231 00	Loctite 573	50 ml	
C = 502 232 00	Loctite 601	50 ml	
D = 502 233 00	Loctite 221	50 ml	
E = 502 234 00	Loctite 648	10 ml	
F = 502 238 00	Technicoll 8058	0,75 kg	
+ 502 239 00	Technicoll 8367	0,75 kg	
G = 502 565 01	Loctite IS 407	20 g	
H = 502 825 01	Silicon	30 ml D1	
J = 502 830 03	Hochtemp. Paste	100 ml	

M 01

Kurbelgehäuse
Crankcase
Carter moteur
Caja cigueñal
Basamento motore

Tafel Nr.
Tabl.No.
Tavola N.

03

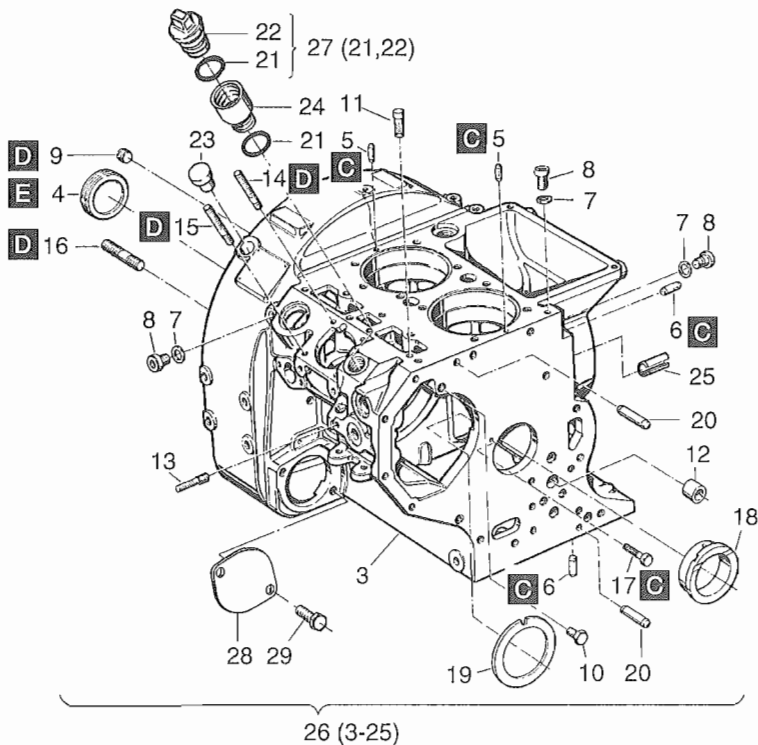

Fig.- No.	HATZ Ident-No.	Stück Qty.			P / W d / D	Bemerkungen Notes
		Z 788	Z 789	Z 790		
1	-----	-	-	-		
2	-----	-	-	-		
3	-----	-	-	-		
4	-----	-	-	-		
5	03179900	2	2	2		
6	03212300	2	2	2		
7	50062400	3	3	3	D1	A 10 x 13,5 DIN 7603 - Cu
8	50062300	3	3	3		M 10 x 1 DIN 908
9	50043700	1	1	1		M 12 x 1,5 DIN 906
10	03272301	1	1	1		
11	03124000	1	1	1		
12	03216700	1	1	1		
13	03612500	2	2	2		
14	50038100	2	2	2		M 8 x 25 DIN 939-5.6
15	50038000	2	2	2		M 8 x 25 DIN 938-5.6
16	50040100	4	4	4		M 10 x 20 DIN 835-8.8
17	03298600	1	1	1		
18	03211502	1	1	1		
18	03262302	1	1	1		- 0,5 mm
19	03558200	1	1	1		
20	03169300	2	2	2		
21	50153800	2	2	2	D1	
22	-----	-	-	-		
23	50237600	1	1	1		
24	03658400	1	1	1		
25	50205600	1	1	1		10 x 12 DIN 7346
26	00564302	1	1	1		
27	00632101	1	1	1	W1	
28	03033100	1	1	1		
29	50030800	2	2	2		M 12 x 16 DIN 933-8.8

M 01

Kurbelgehäuse
Crankcase
Carter moteur
Caja cigueñal
Basamento motore

M 10

Ölpumpe
Oil pump
Pompe à huile
Bomba de aceite
Pompa olio

Tafel Nr.
Tabl.No.
Tavola N.

04

Fig.- No.	HATZ Ident-No.	Stück Qty.			P / W d / D	Bemerkungen Notes
		Z 788	Z 789	Z 790		
1	03212400	1	1	-	D1	
2	03211900	1	1	-		
3	50025400	2	2	-		M 6 x 10 DIN 933-8.8
4	-----	-	-	-		
5	40022401	1	1	1	D1	
6	00318800	1	1	1		
7	03180400	1	1	1		
8	-----	-	-	-		
9	-----	-	-	-		
10	50038800	1	1	1		M 8 x 55 DIN 835-5.6
11	03050100	1	1	1		
12	03149700	1	1	1		
13	03158800	1	1	1		
14	03136500	1	1	1		
15	03158900	1	1	1	D1	
16	00363500	1	1	1		
17	50000900	1	1	1	D7	A 8 x 11,5 DIN 7603 - Cu
18	40028400	1	1	1		M 8 SSN 440-8 Cu
19	03438000	1	1	1		
20	50030800	1	1	1		M 12 x 16 DIN 933-8.8
21	00328802	1	1	1		
22	50001600	1	1	1	D2	A 22 x 27 DIN 7603 - Cu
23	50044300	1	1	1		M 22 x 1,5 DIN 908
24	03211801	1	1	1	D1	
25	03121300	1	1	1		
26	50051900	2	2	2		M 8 x 20 DIN 912-8.8
27	40038100	1	1	1	W4	
28	-----	-	-	-		
29	50010500	1	1	1		A 4 x 4 x 12 DIN 6885
30	50002800	5	5	5		8 DIN 128
31	50027500	5	5	5		M 8 x 35 DIN 931-8.8
32	03122700	1	1	1		
33	50061700	1	1	1		A 10 DIN 137
34	40028600	1	1	1		M 10 SSN 440-8 Cu
35	00410900	1	1	1		

M 01

Kurbelgehäuse
Crankcase
Carter moteur
Caja cigueñal
Basamento motore

M 10

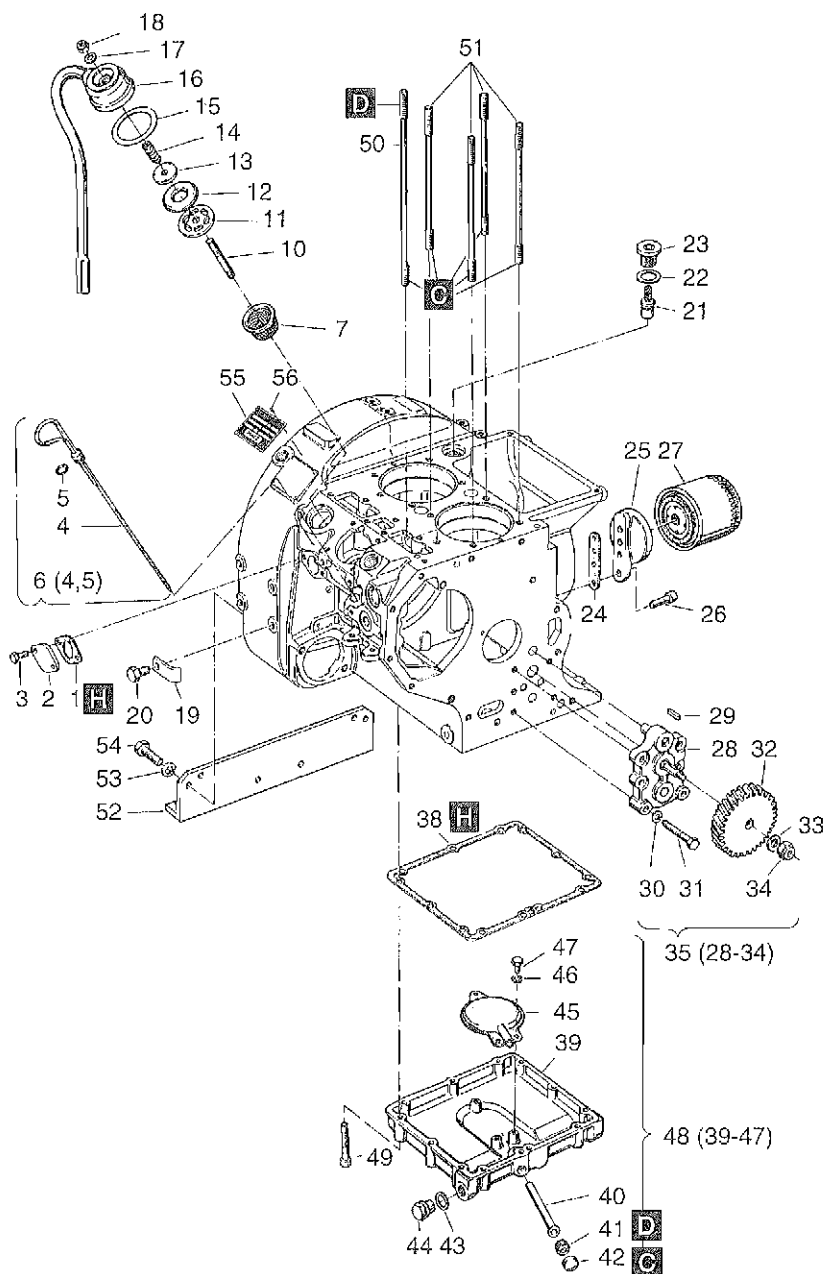
Ölpumpe
Oil pump
Pompe à huile
Bomba de aceite
Pompa olio

Tafel Nr.
Tabl.No.
Tavola N.

04

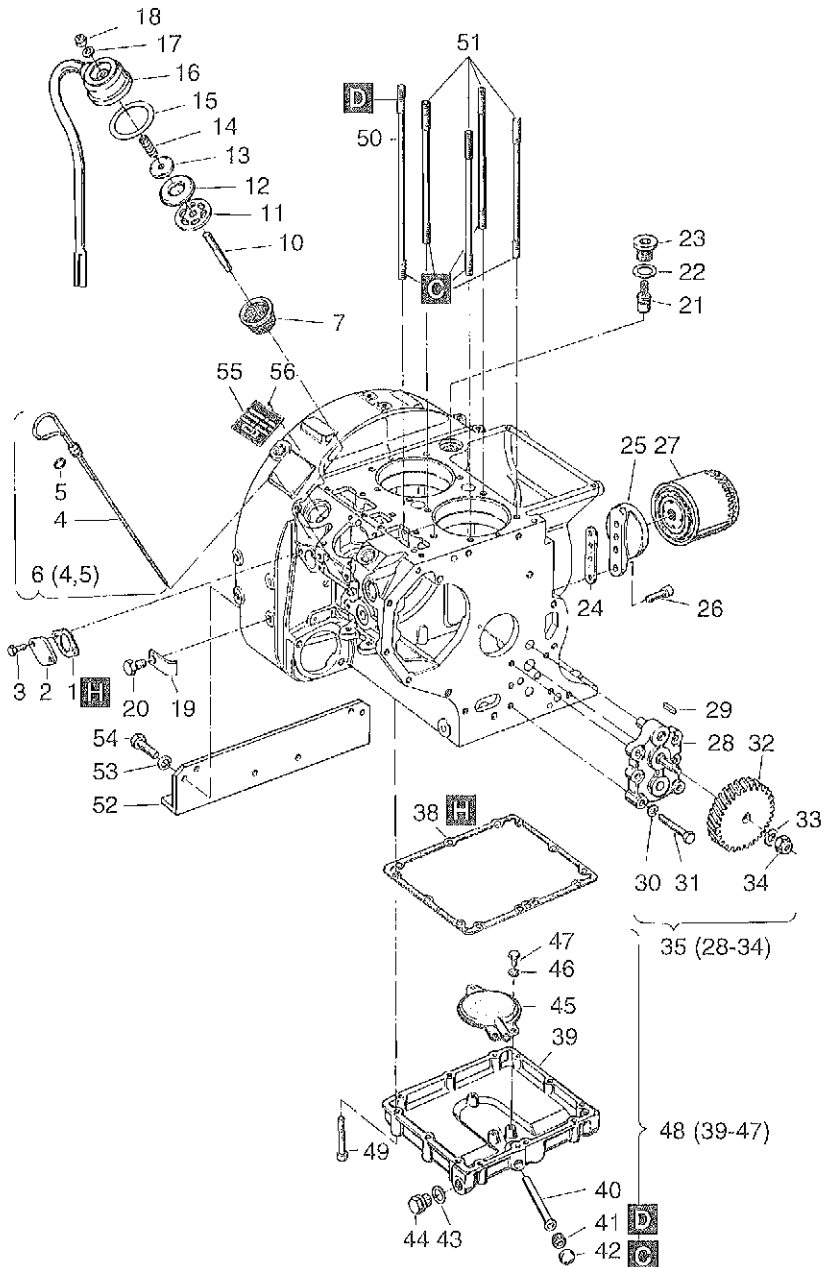

Fig.- No.	HATZ Ident-No.	Stück Qty.			P / W d / D	Bemerkungen Notes
		Z 788	Z 789	Z 790		
36	-----	-	-	-		
37	-----	-	-	-		
38	03212100	1	1	1	D1	
39	-----	-	-	-		
40	03258402	1	1	1		
41	03331801	1	1	1		
42	50043100	1	1	1		18 DIN 443-ROH
43	50001600	2	2	2	W4,D2	A 22 x 27 DIN 7603 - Cu
44	50044400	2	2	2	W1	CM 22 x 1,5 DIN 7604
45	03212000	1	1	1		
46	50002700	3	3	3		6 DIN 128
47	50025400	3	3	3		M 6 x 10 DIN 933-8.8
48	00561903	1	1	1		
49	50080800	12	12	12		M 8 x 42 DIN 912-8.8
50	03340900	2	2	2		
51	03341000	8	8	8		
52	03121500	1	1	1		
53	50002900	6	6	6		10 DIN 128
54	50029200	6	6	6		M 10 x 25 DIN 933-8.8
55	03225504	1	1	1		
56	40002500	4	4	4		

M 02

Kurbelwelle
Crankshaft
Vilebrequin
Cigüeñal
Albero a gomito

M 03

Lagerflansch
Bearing flange
Palier
Brida de cojinete
Supporto

Tafel Nr.
Tabl.No.
Tavola N.

05

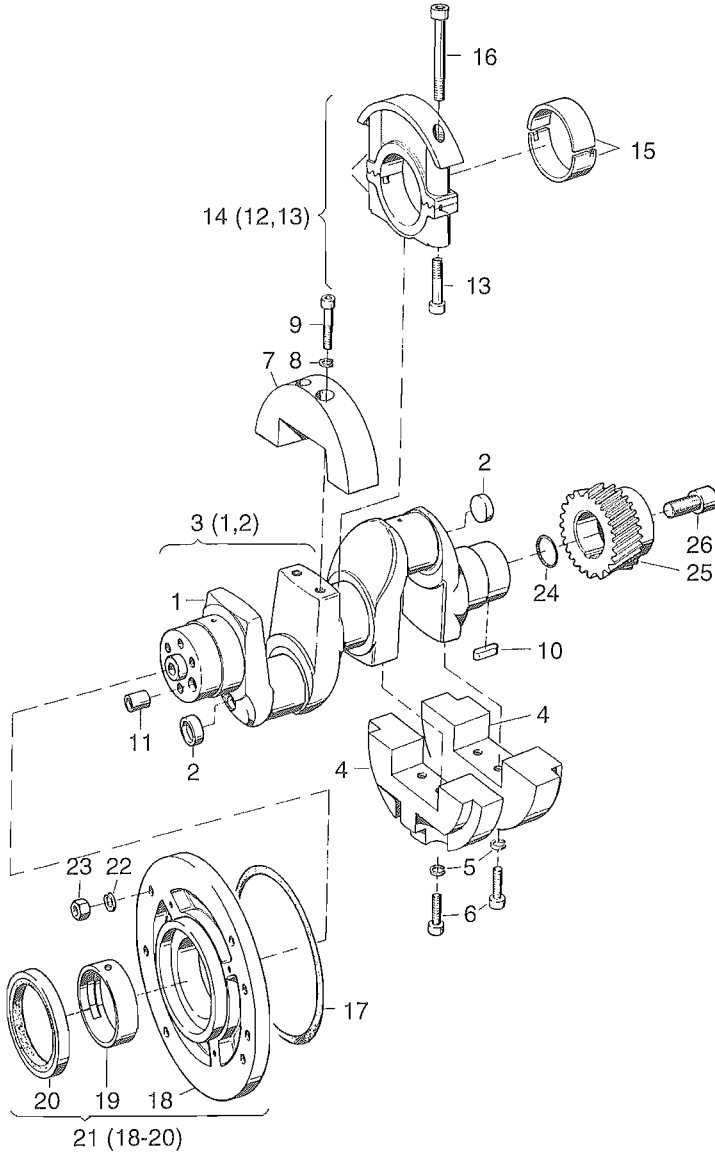

Fig.- No.	HATZ Ident-No.	Stück Qty.			P / W d / D	Bemerkungen Notes
		Z 788	Z 789	Z 790		
1	-----	-	-	-		
2	50043200	2	2	2		25 DIN 443
3	00644500	1	-	-		
3	00530200	-	1	1		
4	03121602	2	2	2		
5	50002900	4	4	4		10 DIN 128
6	50054200	4	4	4		M 10 x 30 DIN 912-10.9
7	03349601	1	1	1		
8	50002900	2	2	2		10 DIN 128
9	50054800	2	2	2		M 10 x 45 DIN 912-10.9
10	50011200	1	1	1		A 6 x 6 x 25 DIN 6885
11	03123700	1	1	1		
12	-----	-	-	-		
13	50056700	2	2	2		M 12 x 55 DIN 912-10.9
14	00363700	1	1	1		
15	03213400	1	1	1		
15	03262400	1	1	1		- 0,5 mm
16	50057200	2	2	2		M 12 x 110 DIN 912-10.9
17	40037100	1	1	1	D1	
18	03121803	1	1	1		
19	03213500	1	1	1		
19	03262500	1	1	1		- 0,5 mm
20	50114701	1	1	1	D1	
21	00363802	1	1	1		
22	50002900	4	4	4		10 DIN 128
23	50023500	4	4	4		M 10 DIN 934-8
24	40023400	1	1	1	D1	32 x 3
25	03120200	1	1	1		
26	50057300	1	1	1		M 16 x 35 DIN 912-10.9

M 04

Nockenwelle, Regler, Drehzahlverstellung
Camshaft, Governor, Speed control
Abre à cames, Regulateur, réglage régime
Arbol de levas, Regulador, Ajuste de revoluciones
Albero a camme, Regolatore, Regolatore di giri

Tafel Nr.
Tabl.No.
Tavola N.

06

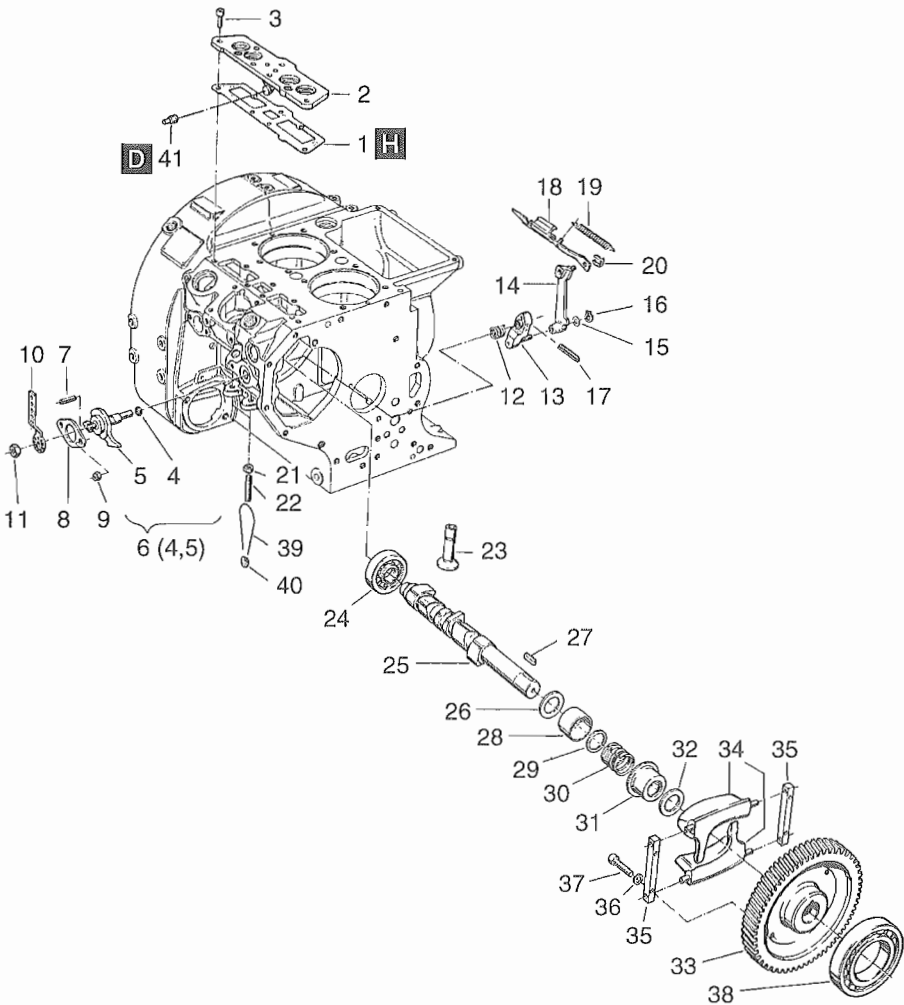

Fig.- No.	HATZ Ident-No.	Stück Qty.			P / W d / D	Bemerkungen Notes
		Z 788	Z 789	Z 790		
1	03216401	1	1	1	D1	
2	00563101	1	1	1		
3	50051800	7	7	7		M 8 x 18 DIN 912-8.8
4	40081700	2	2	2	D2	12 x 2
5	-----	-	-	-		
6	00319301	1	1	1		
7	50034500	1	1	1		4 x 14 DIN 1481
8	03212600	1	1	1		
9	40028400	2	2	2		M 8 SSN 440-8 Cu
10	03211600	1	1	1		
11	50023800	1	1	1		BM 10 DIN 439-6
12	03212201	1	1	1		
13	00363310	1	1	1		
14	00363400	1	1	1		
15	50125800	1	1	1		8 x 14 x 0,5 DIN 988
16	50019400	1	1	1		8 x 0,8 DIN 471
17	50034600	1	1	1		4 x 18 DIN 1481
18	00411201	1	1	1		
19	03189900	1	1	1		
20	40014100	1	1	1		
21	5Q022900	2	2	2		M 8 DIN 934-8
22	03245900	2	2	2		
23	03211700	4	4	4		
24	50014800	1	1	1		
25	03345801	1	1	1		
26	03457300	1	1	1		
27	50011200	1	1	1		A 6 x 6 x 25DIN 6885
28	03399300	1	1	1		
29	03442601	1	1	1		
30	03442700	1	1	1		2,8 mm ø 1500 min ⁻¹
30	03442800	1	1	1		3,2 mm ø 1800 min ⁻¹
30	03640100	1	1	1		3,6 mm ø < 2300 min ⁻¹
30	03398601	1	1	1		4,0 mm ø > 2300 min ⁻¹
31	03399200	1	1	1		
32	03442500	1	1	1		
33	03124201	1	1	1		

M 04

Nockenwelle, Regler, Drehzahlverstellung
Camshaft, Governor, Speed control
Abre à cames, Regulateur, réglage régime
Arbol de levas, Regulador, Ajuste de revoluciones
Albero a camme, Regolatore, Regolatore di giri

Tafel Nr.
Tabl.No.
Tavola N.

06

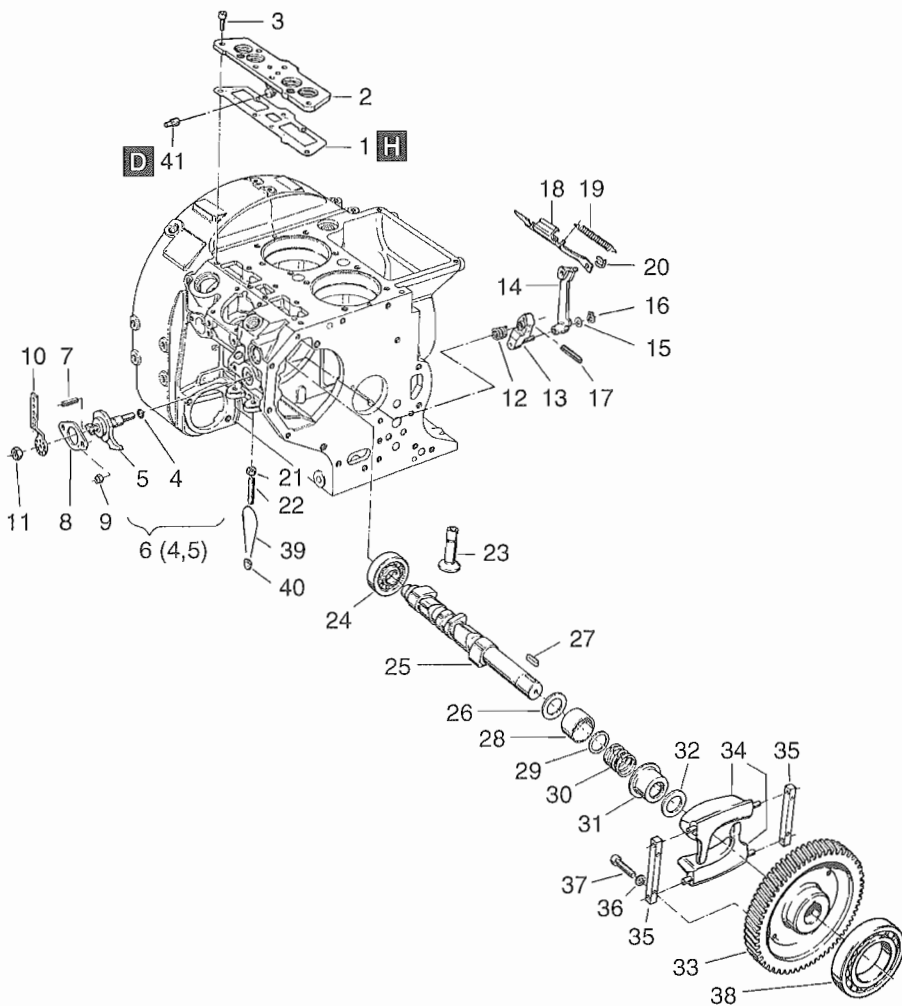

Fig.- No.	HATZ Ident-No.	Stück Qty.			P / W d / D	Bemerkungen Notes
		Z 788	Z 789	Z 790		
34	03398400	2	2	2		
35	03398700	2	2	2		
36	50002800	4	4	4	8	DIN 128
37	03457600	4	4	4		
38	50405400	1	1	1	C5	
39	40021500	1	1	1		
40	40021400	1	1	1		
41	03774200	1	1	1		

M 05

Kolben, Pleuel
Piston, Conrod
Piston, Bielle
Embolo, Biela
Pistone, Biella

M 06

Zylinder
Cylinder
Cilindre
Cilindro
Cilindro

Tafel Nr.
Tabl.No.
Tavola N.

07

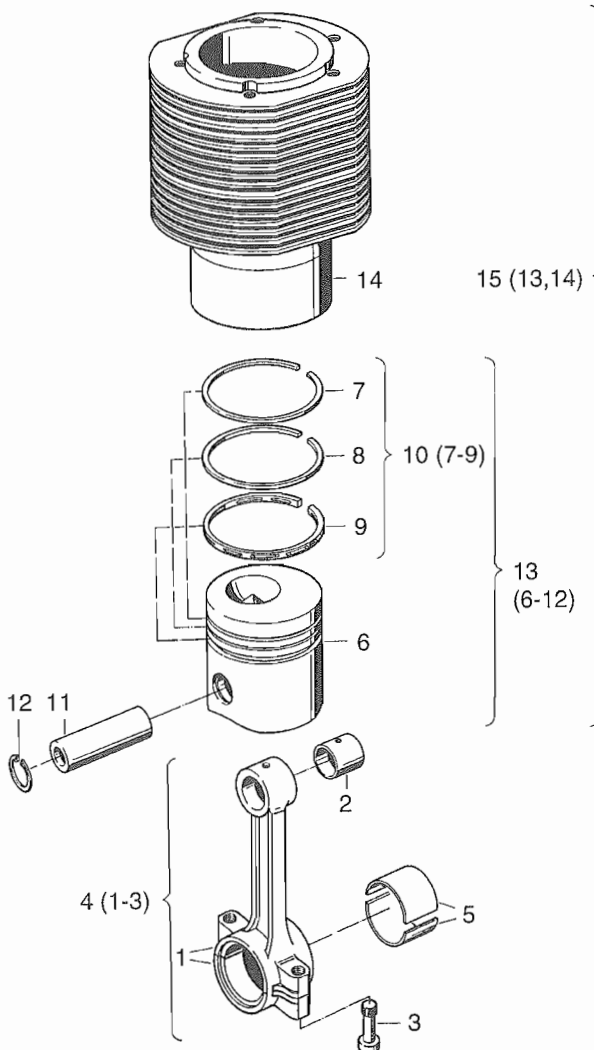

Fig.- No.	HATZ Ident-No.	Stück Qty.			P / W d / D	Bemerkungen Notes
		Z 788	Z 789	Z 790		
1	-----	-	-	-		
2	03012800	2	2	2		
3	03170400	4	4	4		
4	00530400	2	2	2		
5	03341300	2	2	2		
5	03338000	2	2	2		- 0,5 mm
6	-----	-	-	-		
7	-----	-	-	-		
8	-----	-	-	-		
9	-----	-	-	-		
10	01238500	2	2	2		
10	01238600	2	2	2		+ 0,5 mm
10	01238700	2	2	2		+ 1,0 mm
11	50080700	2	2	2		
12	50020700	4	4	4		28 x 1,2 DIN 472
13	00639102	2	-	-		
13	01235101	2	-	-		+ 0,5 mm
13	00639602	2	-	-		+ 1,0 mm
13	00530302	-	2	2		
13	01235201	-	2	2		+ 0,5 mm
13	00567802	-	2	2		+ 1,0 mm
14	-----	-	-	-		
15	00649800	2	-	-		
15	00566800	-	2	2		

M 07

Zylinderkopf
Cylinder head
Culasse
Culata
Testa

Tafel Nr.
Tabl.No.
Tavola N.

08

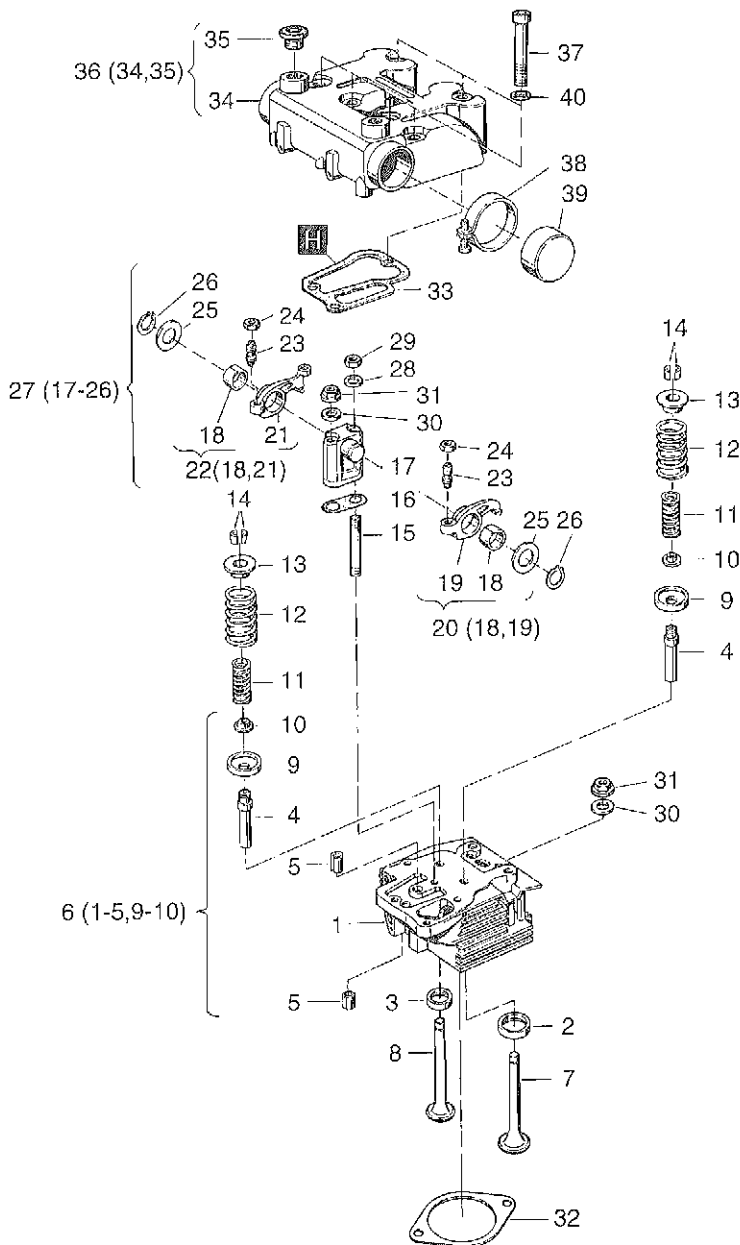

Fig.- No.	HATZ Ident-No.	Stück Qty.			P / W d / D	Bemerkungen Notes
		Z 788	Z 789	Z 790		
1	-----	-	-	-		
2	-----	-	-	-		
3	-----	-	-	-		
4	03325710	4	4	4		
5	50035800	6	6	6		12 x 18 DIN 7346
6	00603020	2	2	2		
7	03340600	2	2	2		
8	03340500	2	2	2		
9	03183710	4	4	4		
10	03184410	4	4	4		
11	03183500	4	4	4		
12	03325600	4	4	4		
13	03043402	4	4	4		
14	03292600	4	4	4		
15	50039100	2	2	2		M 8 x 70 DIN 835-5.6
16	03215400	2	2	2	d1	
17	03340400	2	2	2		
18	03184100	4	4	4		
19	-----	-	-	-		
20	00532500	2	2	2		
21	-----	-	-	-		
22	00532602	2	2	2		
23	03043100	4	4	4		
24	03149000	4	4	4	W2	
25	03233200	0...4	0...4	0...4		0,20 mm
25	03233300	0...4	0...4	0...4		0,30 mm
25	03456000	0...4	0...4	0...4		0,40 mm
26	50020200	4	4	4		19 x 1,2 DIN 471
27	00563300	2	2	2		
28	50148100	2	2	2	P2	8,4 DIN 125-St A3C
29	50022900	2	2	2	P2	M 8 DIN 934-8
30	03214800	10	10	10	P5	
31	03215000	10	10	10	P5	

M 07

Zylinderkopf
Cylinder head
Culata
Testa

Tafel Nr.
Tabl.No.
Tavola N.

08

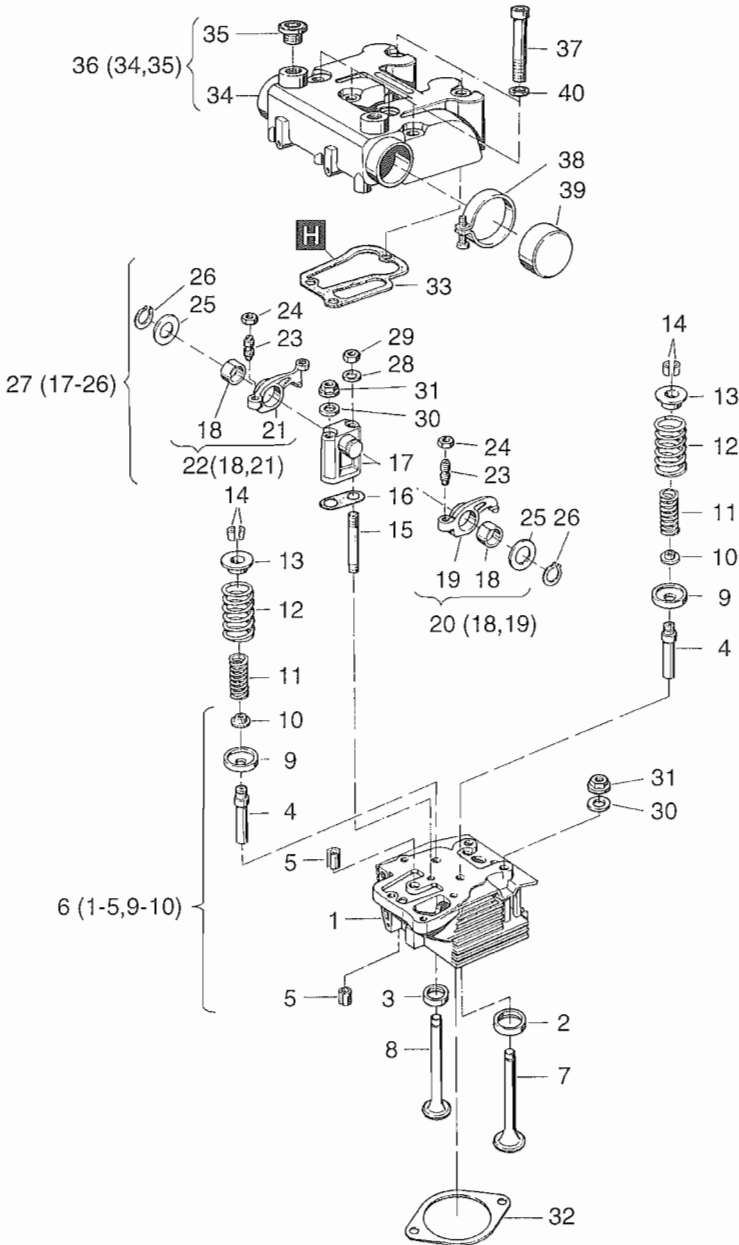

Fig.- No.	HATZ Ident-No.		Stück Qty.		P / W d / D	Bemerkungen Notes
		Z 788	Z 789	Z 790		
32	03341600	0...2	0...2	0...2		0,5 mm
32	03341700	0...2	0...2	0...2		0,6 mm
32	03341800	0...2	0...2	0...2	d1	0,7 mm
32	03341900	0...2	0...2	0...2		0,8 mm
32	03342000	0...2	0...2	0...2	d1	0,9 mm
32	03342100	0...2	0...2	0...2		1,0 mm
32	03342200	0...2	0...2	0...2		1,1 mm
33	03216212	2	2	2	W4,d2	
34	-----	-	-	-		
35	50086300	2	2	2		M 20 x 1,5 DIN 908
36	00630210	1	1	1		
37	50120900	6	6	6		M 8 x 85 DIN 912-8.8 A3C
38	40095500	1	1	1		
39	00575900	1	1	1		
40	03214800	6	6	6		

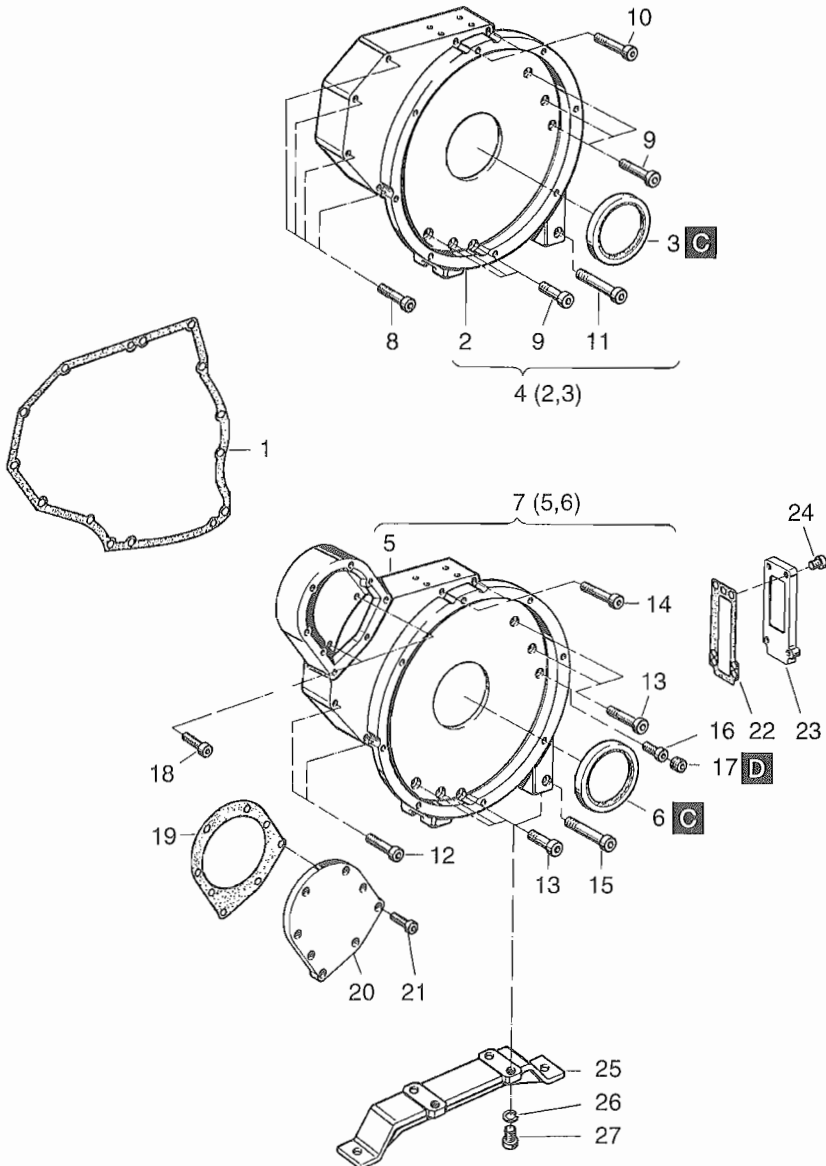

Fig.- No.	HATZ Ident-No.	Stück Qty.			P / W d / D	Bemerkungen Notes
		Z 788	Z 789	Z 790		
1	03216800	1	1	1	D1	
2	-----	-	-	-		
3	40034700	1	1	1	D1	
4	00364601	1	1	1		
5	-----	-	-	-		
6	40034700	1	1	1	D1	
7	00411501	1	1	1		„H“
8	50052900	4	4	4		M 8 x 60 DIN 912-8.8
9	50055100	6	6	6		M 10 x 55 DIN 912-8.8
10	50055400	2	2	2		M 10 x 65 DIN 912-8.8
11	50055600	1	1	1		M 10 x 80 DIN 912-8.8
12	50052900	2	2	2		M 8 x 60 DIN 912-8.8
13	50055100	5	5	5		M 10 x 55 DIN 912-8.8
14	50055400	2	2	2		M 10 x 65 DIN 912-8.8
15	50055600	1	1	1		M 10 x 80 DIN 912-8.8
16	50054000	1	1	1		M 10 x 25 DIN 912-8.8
17	50061500	1	1	1		M 20 x 1,5 DIN 906
18	50051900	2	2	2		M 8 x 20 DIN 912-8.8
19	03270200	1	1	1	D1	
20	03233600	1	1	1		
21	50051900	6	6	6		M 8 x 20 DIN 912-8.8
22	03270400	1	1	1	D1	
23	03233700	1	1	1		
24	50051900	4	4	4		M 8 x 20 DIN 912-8.8
25	03394500	1	1	1		
26	50263700	4	4	4		A 12 DIN 127
27	50031100	4	4	4		M 12 x 28 DIN 933-8.8

M 12

Startfüllung
Extra fuel device
Sobree aliment.-arranque
Supplemento

M 14

Einspritzausrüstung
Injection equipment
Equipement d'injection
Equipo de inyección
Equipaggiamento d'iniezione

Tafel Nr.
Tabl.No.
Tavola N.

10

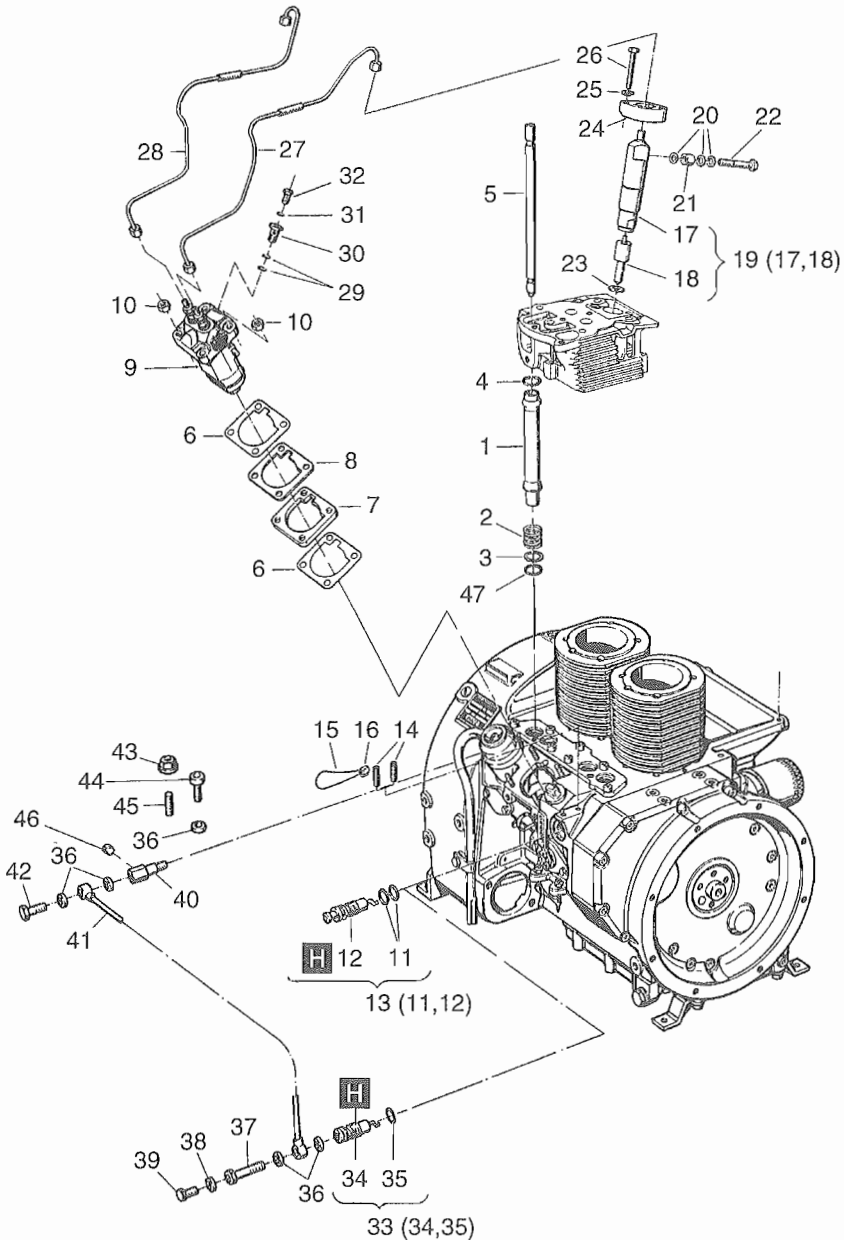

Fig.- No.	HATZ Ident-No.	Stück Qty.			P / W d / D	Bemerkungen Notes
		Z 788	Z 789	Z 790		
1	03216300	4	4	4		
2	03185100	4	4	4		
3	03185200	4	4	4		
4	50258000	4	4	4	d2	17 x 3
5	00364400	4	4	4		
6	03190700	2	2	2	D2	
7	03053801	1	1	1		
8	03190601	0...1	0...1	0...1		0,20 mm
8	03190800	0...1	0...1	0...1		0,30 mm
8	03190900	0...1	0...1	0...1		0,50 mm
9	40005711	1	1	-		
12	40072110	-	-	1		
10	50022900	4	4	4		M 8 DIN 934-8
11	40022900	2	2	2	D2	
12	-----	-	-	-		
13	00341601	1	1	1		
14	03272200	2	2	2		
15	40021500	1	1	1		
16	40021400	1	1	1		
17	-----	-	-	-		
18	40072400	2	2	2	P1	
19	40072500	2	2	2		
20	50000900	6	6	6	d3, D7	A 8 x 11,5 DIN 7603 - Cu
21	03292900	2	2	2		
22	03292800	2	2	2		
23	40055800	2	2	2	d1	
24	03285000	2	2	2		
25	50002800	4	4	4	P4	8 DIN 128
26	50028100	4	4	4		M 8 x 50 DIN 931-8.8
27	03342500	1	1	1		
28	03342600	1	1	1		

M 12

Startfüllung
Extra fuel device
Surcharge
Sobre aliment.-arranque
Supplemento

M 14

Einspritzrüstung
Injection equipment
Equipement d'injection
Equipo de inyección
Equipaggiamento d'iniezione

Tafel Nr.
Tabl.No.
Tavola N.

10

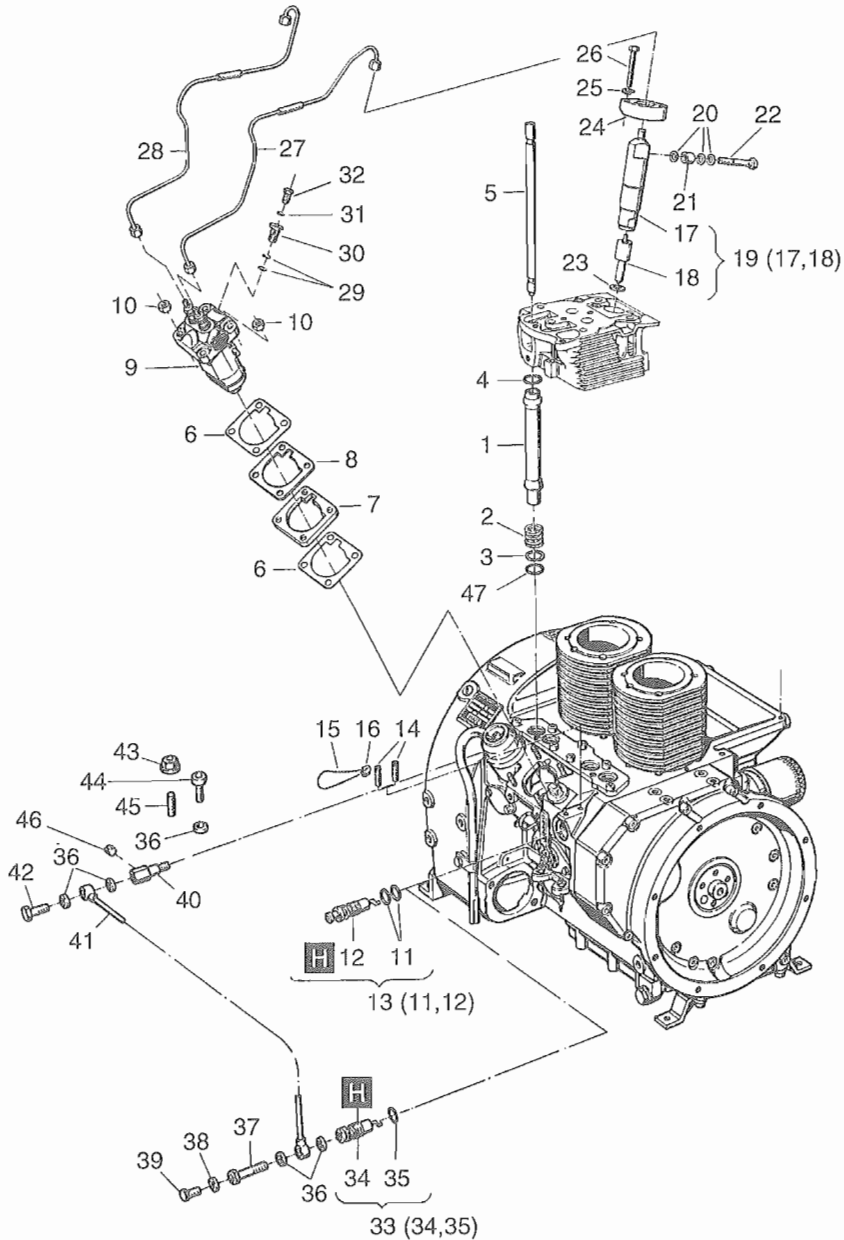

Fig.- No.	HATZ Ident-No.	Stück Qty.			P / W d / D	Bemerkungen Notes
		Z 788	Z 789	Z 790		
29	50001100	2	2	2	D2	A 12 x 15,5 DIN 7603 - Cu
30	03613500	1	1	1		
31	50000800	1	1	1		A 6,5 x 9,5 DIN 7603 - Cu
32	03613600	1	1	1		
33	00874900	1	1	1		
34	-----	-	-	-		
35	50169100	1	1	1	D1	19 x 1,8
36	50000900	5	5	5	D7	A 8 x 11,5 DIN 7603 - Cu
37	03724800	1	1	1		
38	50000800	1	1	1	D1	A 6,5 x 9,5 DIN 7603 - Cu
39	50025300	1	1	1		M 6 x 8 DIN 933 - 8.8
40	03702601	1	1	1		
41	01006600	1	1	1		
42	03946200	1	1	1		M 8 x 1
43	50183600	1	1	1		M 8 SEAL LOCK
44	03701600	1	1	1		M 8 x 10
45	03657400	1	1	1		M 8 X 30
46	50043600	1	1	1		M 10 x 1 DIN 906
47	40022800	4	4	4	d2	15 x 3,2

M 17 Schwungrad
Flywheel
Volant
Volante
Volano

M 26 Luftführung
Air ducting
Carter ventilation
Conducción de aire
Carter ventilatore

Tafel Nr.
Tabl.No.
Tavola N.
11

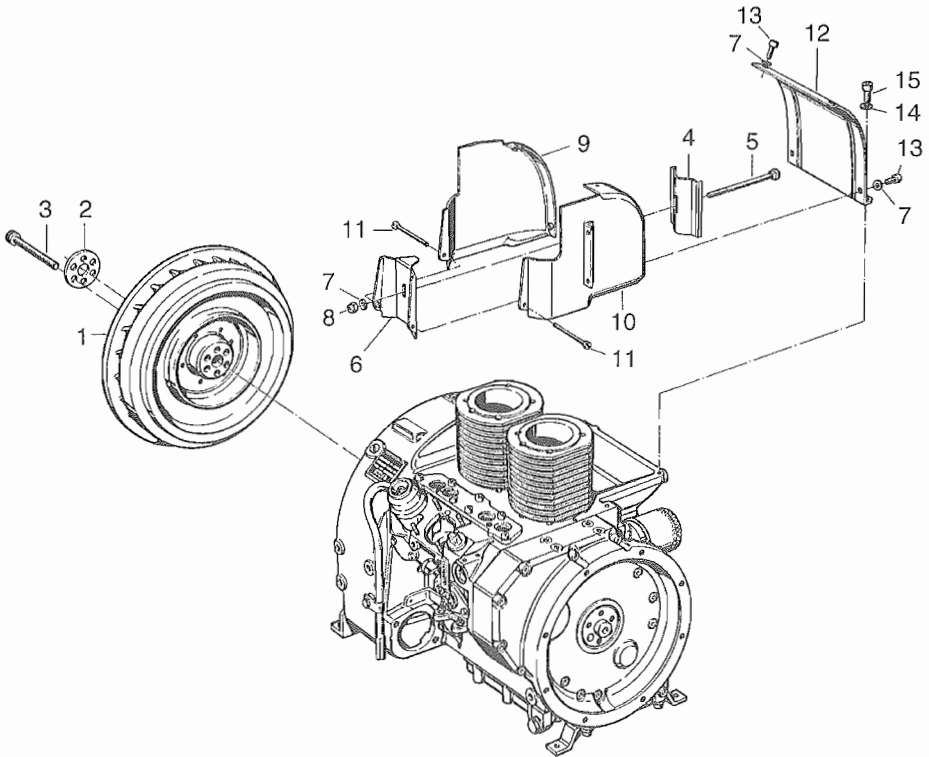

Fig.- No.	HATZ Ident-No.	Stück Qty.			P / W d / D	Bemerkungen Notes
		Z 788	Z 789	Z 790		
1	03434201	1	1	1		
2	03216900	1	1	1		
3	50057000	6	6	6		6 BKM 12 x 75 DIN 912 - 12.9
4	03125401	1	1	1		
5	50063300	1	1	1		M 6 x 120 DIN 603 - 4.6
6	00368900	1	1	1		
7	50144500	5	5	5	6,4	DIN 125-St A3C
8	40028300	1	1	1	M 6	SSN 440-8 Cu
9	00609700	1	1	1		
10	00609800	1	1	1		
11	50049600	2	2	2		AM 5 x 60 DIN 84-4.8
12	03122902	1	1	1		
13	50062700	4	4	4	M 6 x 10	DIN 912-8.8
14	50002800	2	2	2	8	DIN 128
15	50051400	2	2	2	M 8 x 12	DIN 912-8.8

Fig.- No.	HATZ Ident-No.	Stück Qty.			P / W d / D	Bemerkungen Notes
		Z 788	Z 789	Z 790		
1	03123300	2	2	2		
2	50145900	4	4	4		B 10,5 DIN 125-St A3C
3	03217500	1	1	1		
5	50054000	2	2	2		M 10 x 25 DIN 6912-8.8
6	50055800	2	2	2		M 10 x 85 DIN 6912-8.8
7	40011400	2	2	2		
8	-----	-	-	-		
9	40032701	1	1	1	P1	
10	-----	-	-	-		
11	-----	-	-	-		
12	40007300	1	1	1	W2	
13	50062900	1	1	1	W1	B 8,4 DIN 9021-St
14	40028400	1	1	1	W1	VM8 DIN 980-8 A3C
15	00349700	1	1	1		
16	03188401	1	1	1	W2	
17	50062700	5	5	5	W5	M 6 x 10 DIN 912-8.8
18	00510400	1	1	1		
19	03188600	2	2	2		
20	00778800	4	4	4		
21	03537700	4	4	4		
22	50001200	2	2	2	D2	A 14 x 18 DIN 7603 - Cu 470 mm
23	03280400	1	1	1		
24	50006400	1	1	1		A 8 DIN 7623
25	50001100	2	2	2	D2	A 12 x 15,5 DIN 7603 - Cu
26	03613500	1	1	1		
27	50000800	1	1	1		A 6,5 x 9,5 DIN 7603 - Cu
28	03613600	1	1	1		
29	03409600	1	1	1		558 mm
30	50000900	2	2	2	D7	A 8 x 11,5 DIN 7603 - Cu
31	50006100	1	1	1		A 2/3 DIN 7623

A 01

Kraftstoffbehälter, Förderpumpe, Filter, Leitungen
Fuel tank, Fuel feed pump, Filter, Pipes
Reservoir à carburant, Pompe d'alimentation, Filtre, Conduites
Depósito combustible, Bomba de alimentación, Filtro, Tubería
Serbatoio combustibile

Tafel Nr.
Tabl.No.
Tavola N.
12

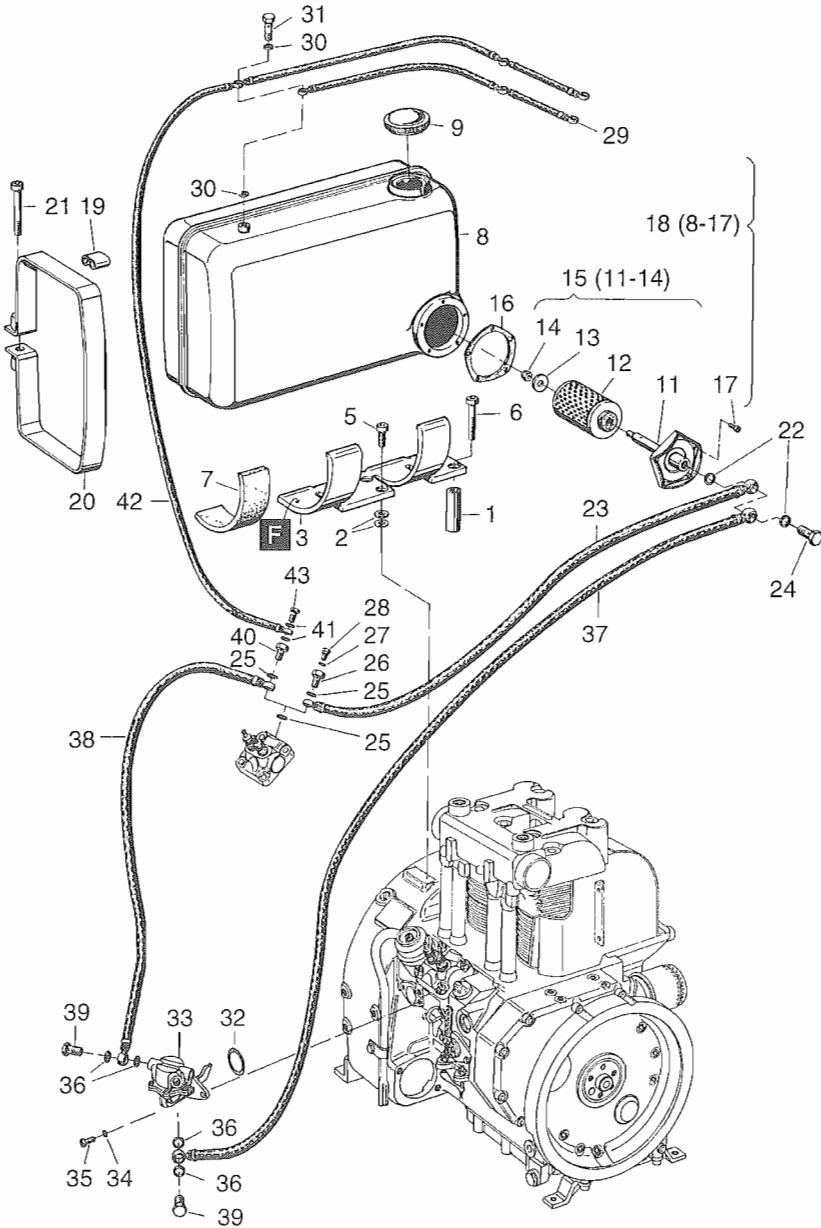

Fig.- No.	HATZ Ident-No.	Stück Qty.			P / W d / D	Bemerkungen Notes
		Z 788	Z 789	Z 790		
32	50129900	1	1	1	D1	
33	01608100	1	1	1		
34	50081200	2	2	2		A 6 DIN 137
35	50050700	2	2	2		M 6 x 16 DIN 912-8.8
36	50001200	4	4	4	W4, D2	A 14 x 18 DIN 7603 - Cu
37	03275500	1	1	1		550 mm
38	03810700	1	1	1		225 mm
39	50006400	2	2	2		A 8 DIN 7623
40	03407700	1	1	1		
41	50000900	2	2	2	D7	A 8 x 11,5 DIN 7603 - Cu
42	03408100	1	1	1		1078 mm
43	50006100	1	1	-		A 2/3 DIN 7623 Zn
43	03747900	-	-	1		

A 01

Filter, Leitungen
Filter, Pipes
Filtre, Conduites
Filtro, Tuberia
Filtro gasolio, Tubazione

Tafel Nr.
Tabl.No.
Tavola N.

13

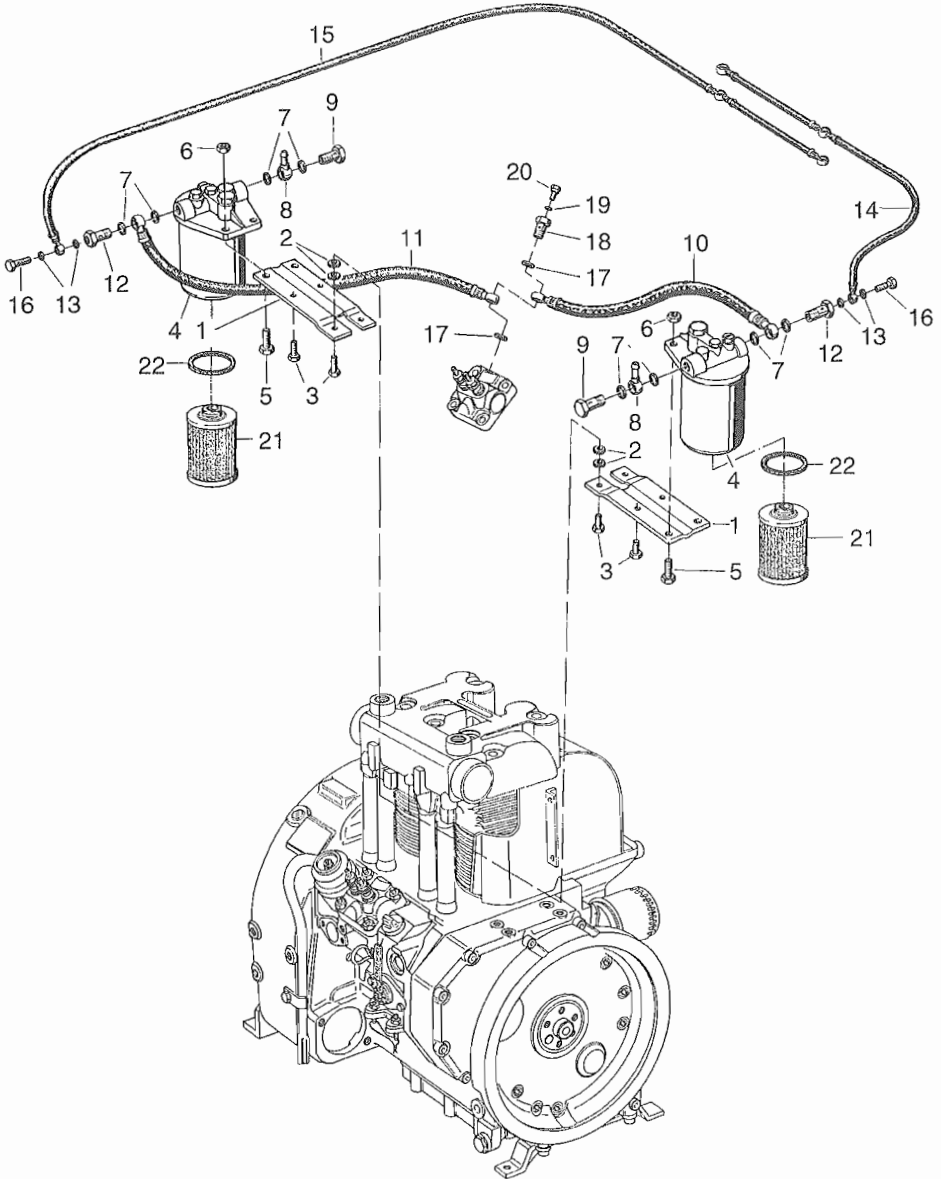

Fig.- No.	HATZ Ident-No.	Stück Qty.			P / W d / D	Bemerkungen Notes
		Z 788	Z 789	Z 790		
1	03275400	1	1	1		
2	50148100	4	4	4		8,4 DIN 125-St A3C
3	50026800	4	4	4		M 8 x 20 DIN 933-8.8
4	40067400	1	1	1		
5	50029200	2	2	2		M 10 x 25 DIN 933-8.8
6	50023500	2	2	2		M 10 DIN 934-8
7	50001200	4	4	-	D2	A 14 x 18 DIN 7603 - Cu
8	50015900	1	1	-		
9	50006400	1	1	-		A 8 DIN 7623
10	03280400	1	1	-		470 mm
11	03262601	1	1	-		315 mm
12	03280700	1	1	-		
13	50000900	2	2	-	D7	A 8 x 11,5 DIN 7603 - Cu
14	03409700	1	1	-		458 mm
15	03409600	1	1	-		558 mm
16	50006100	1	1	-		A 2/3 DIN 7623
17	50001100	2	2	-	D2	A 12 x 15,5 DIN 7603 - Cu
18	03613500	1	1	-		
19	50000800	1	1	-		A 6,5 x 9,5 DIN 7603 - Cu
20	03613600	1	1	-		
21	40007300	1	1	1	W2	
22	49036500	1	1	1	P1	

A 01

Förderpumpe, Leitungen
Fuel feed pump, pipes
Pompe d'alimentation, conduites
Bomba de alimentación, tubería
Pompa A. C., mangueras

Tafel Nr.
Tabl. No.
Tavola N.

14

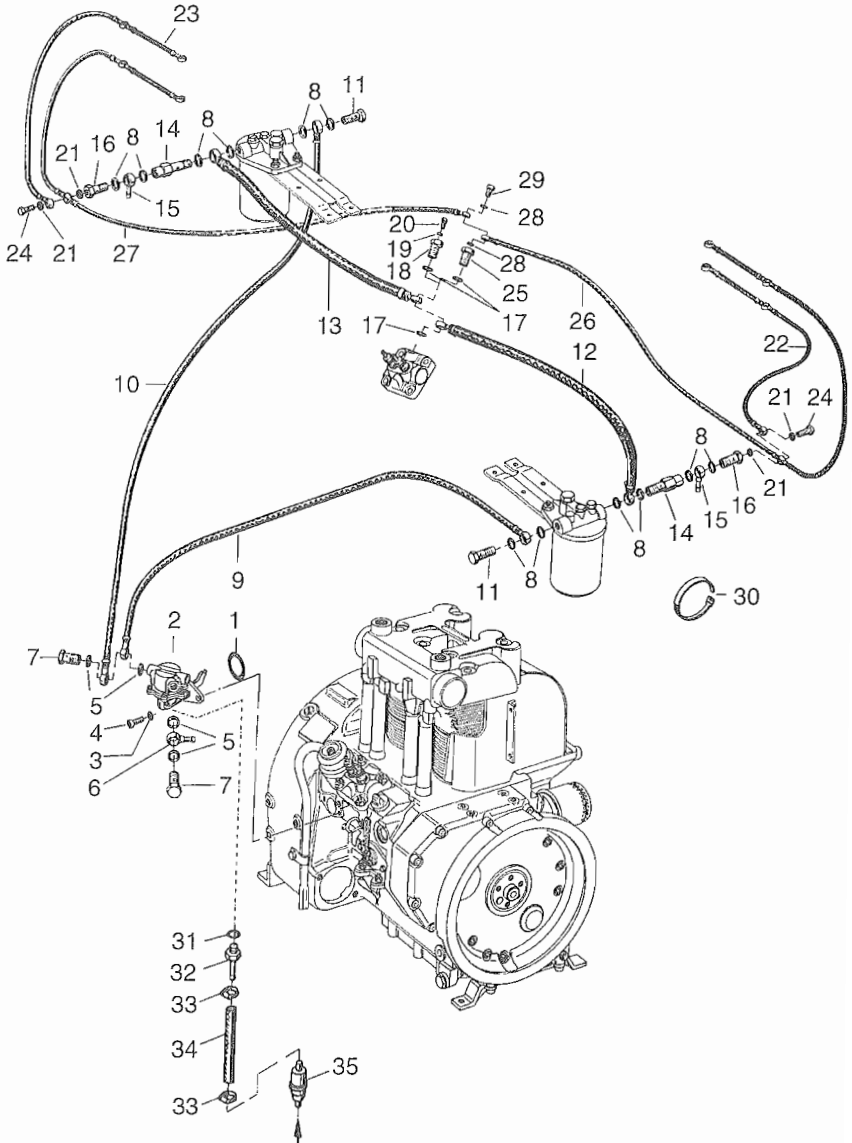

Fig.- No.	HATZ Ident-No.	Stück Qty.			P / W d / D	Bemerkungen Notes
		Z 788	Z 789	Z 790		
1	50129900	1	1	1		32 x 2,5
2	01608100	1	1	1		
3	50081200	2	2	2		A 6 DIN 137
4	50050700	2	2	2		M 6 x 16 DIN 912-8.8
5	50001200	4	4	4	W4	A 14 x 18 DIN 7603-Cu
6	50015900	1	1	1		
7	50006400	2	2	2		A 8 DIN 7623
8	50001200	6	6	6	D2	A 14 x 18 DIN 7603 - Cu
9	03275500	1	1	1		550 mm
10	03275600	1	1	1		345 mm
11	50006400	1	1	1		A 8 DIN 7623
12	03280400	1	1	1		470 mm
13	03151600	1	1	1		365 mm
14	03497700	1	1	1		
15	50015900	1	1	1		
16	03280700	1	1	1		
17	50001100	2	2	2	D2	A 12 x 15,5 DIN 7603 - Cu
18	03613500	1	1	1		
19	50000800	1	1	1		A 6,5 x 9,5 DIN 7603 - Cu
20	03613600	1	1	1		
21	50000900	2	2	2	D7	A 8 x 11,5 DIN 7603 - Cu
22	03409700	1	1	1		458 mm
23	03409600	1	1	1		558 mm
24	50006100	1	1	1		A 2/3 DIN 7623
25	03407700	1	1	1		
26	03409900	1	1	1		998 mm
27	03409800	1	1	1		1098 mm
28	50000900	2	2	2	D7	A 8 x 11,5 DIN 7603 - Cu
29	50006100	1	1	-		A 2/3 DIN 7623 Zn
29	03747900	-	-	1		
30	40092700	1	1	1		
31	50001200	1	1	1		A 14 x 18 DIN 7603 - Cu
32	03466800	1	1	1		
33	40037300	2	2	2		
34	03801200	1	1	1		7 x 220
35	50317000	1	1	1		Vorfilter, prefilter

A 02

Luftfilter
Air filter
Filtre à air
Filtro de aire
Filtro aria

Tafel Nr.
Tabl.No.
Tavola N.

15

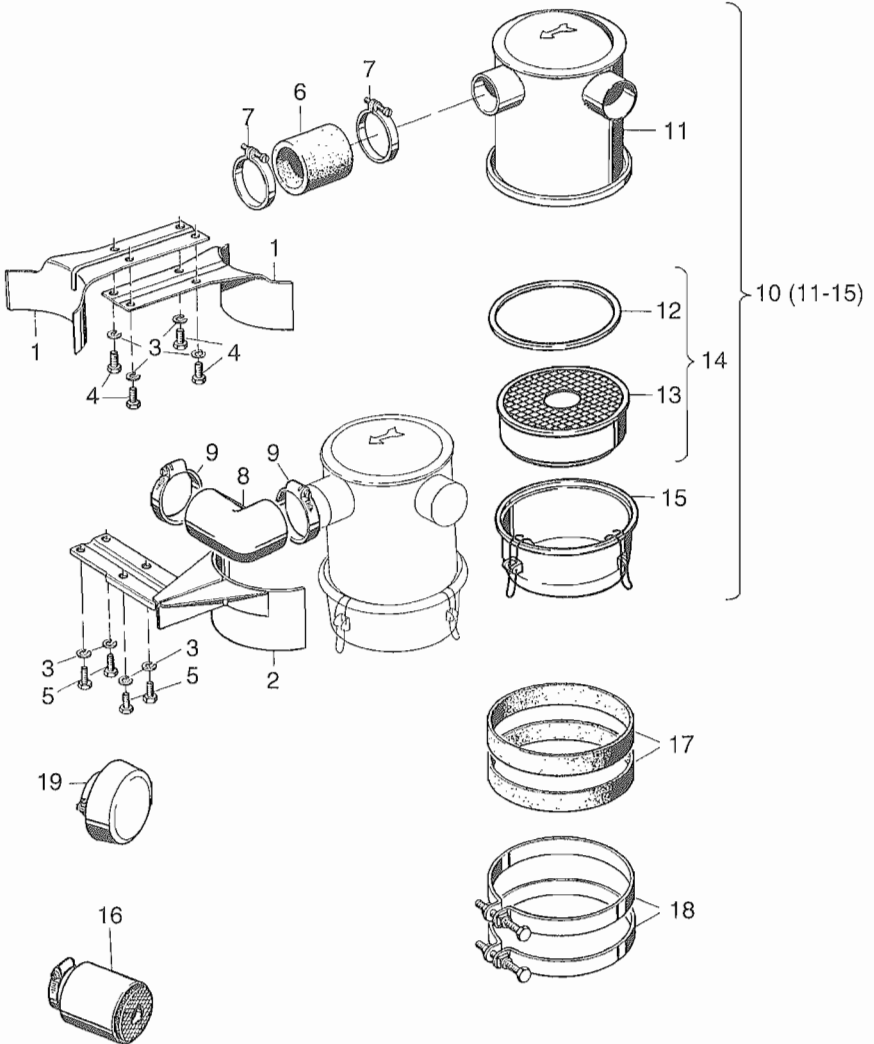

Fig.- No.	HATZ Ident-No.	Stück Qty.			P / W d / D	Bemerkungen Notes
		Z 788	Z 789	Z 790		
1	03125600	1	1	1		
2	00417900	1	1	1		
3	50002800	4	4	4	8	DIN 128
4	50026800	4	4	4	M 8 x 20	DIN 933-8.8
5	50051900	4	4	4	M 8 x 20	DIN 912-8.8
6	03217300	1	1	1		
7	40095500	2	2	2		
8	03275100	1	1	1		
9	40095500	2	2	2		
10	40068810	1	1	1		
11	-----	-	-	-		
12	49021300	1	1	1	P1	
13	-----	-	-	-		
14	49035100	1	1	1		
15	49020900	1	1	1		
16	40042110	1	1	1		
17	03217600	2	2	2		
18	40037200	2	2	2		
19	40071210	1	1	1		

A 03

Abgasrohr, Abgasdämpfer
Exhaust manifold, Exhaust silencer
Tube d'échappement, Silencieux
Tubo de escape, Silenciador
Scarico, Marmitta

Tafel Nr.
Tabl.No.
Tavola N.

16

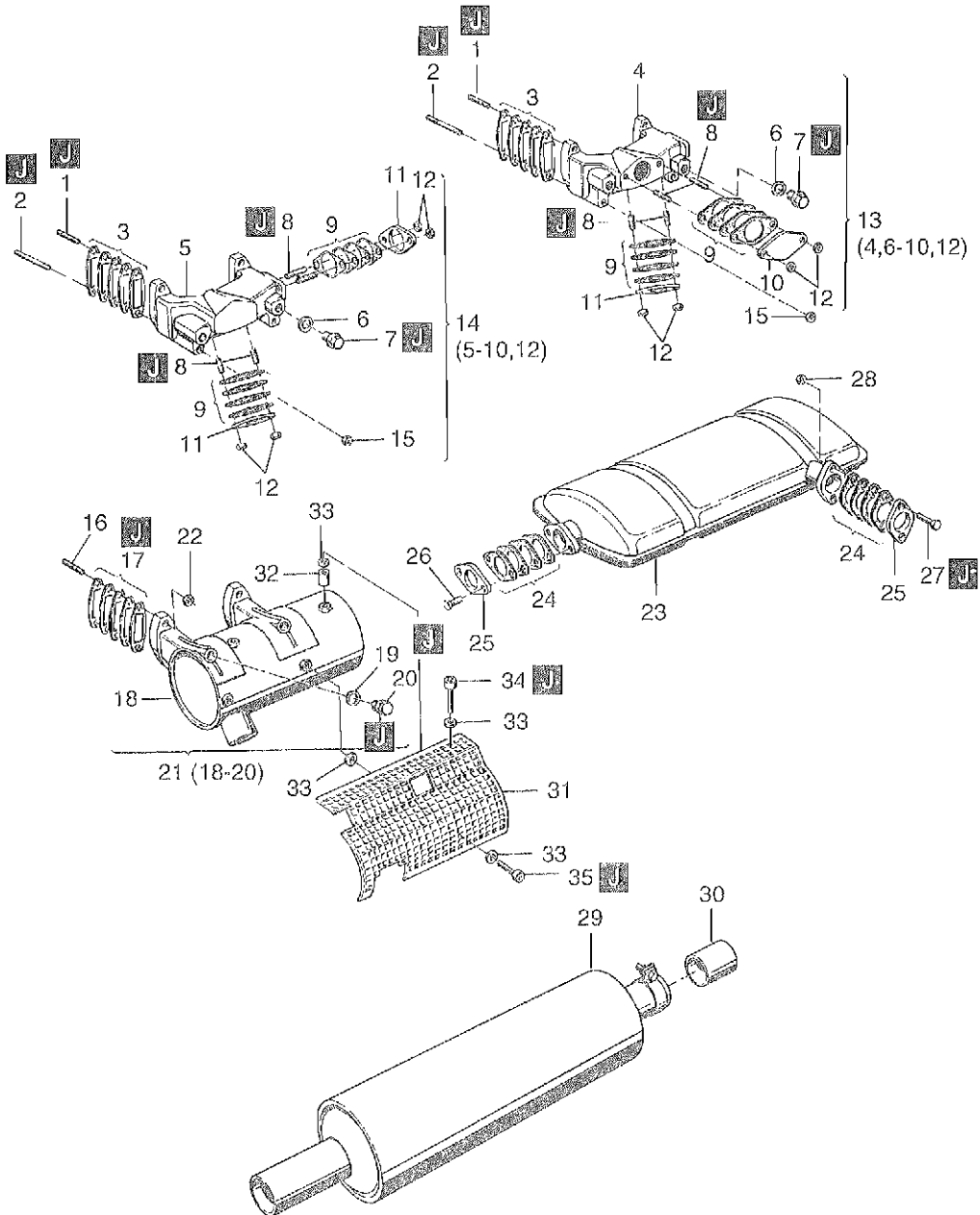

Fig.- No.	HATZ Ident-No.	Stück Qty.			P / W d / D	Bemerkungen Notes
		Z 788	Z 789	Z 790		
1	50037900	2	2	2		M 8 x 25 DIN 835-5.6
2	50039400	2	2	2		M 8 x 105 DIN 835-5.6
3	01285901	1	1	1	d1	
4	-----	-	-	-		
5	-----	-	-	-		
6	03228800	2	2	2		
7	50044700	2	2	2		R 1/4 DIN 910
8	50037300	4	4	4		M 8 x 18 DIN 835-10.9
9	01286000	1	1	1	d1	
10	03263300	1	1	1		
11	03324200	1	1	1		
12	50023000	4	4	4		M 8 Ms DIN 934-Ms
13	00550000	1	1	1		
14	00550100	1	1	1		
15	40081600	4	4	4		
16	50037900	4	4	4		M 8 x 25 DIN 835-5.6
17	01285901	1	1	1	d1	
18	-----	-	-	-		
19	03228800	2	2	2		
20	50044700	2	2	2		R 1/4 DIN 910
21	00585101	1	1	1		
22	40081600	4	4	4		
23	00861800	1	1	1		
24	01286000	1	1	1	d1	
25	03324200	2	2	2		
26	50026800	2	2	2		M 8 x 20 DIN 933-8.8
27	50027000	2	2	2		M 8 x 25 DIN 933-8.8
28	50023000	2	2	2		M 8 Ms DIN 934-Ms
29	00870900	1	1	1		
30	03047901	1	1	1		
31	03721300	1	1	1		
32	03520600	2	2	2		
33	50016800	8	8	8		8,4 DIN 125 Ms
34	50175900	2	2	2		M 8 x 30 DIN 912-8.8 Zn
35	50173100	2	2	2		M 8 x 10 DIN 912-8.8 Zn

A 04

Andrehvorrichtung schs.
Starting device
Dispositif demarrage
Dispositivo de arranque
Dispositivo de avviamento

Tafel Nr.
Tabl.No.
Tavola N.

17

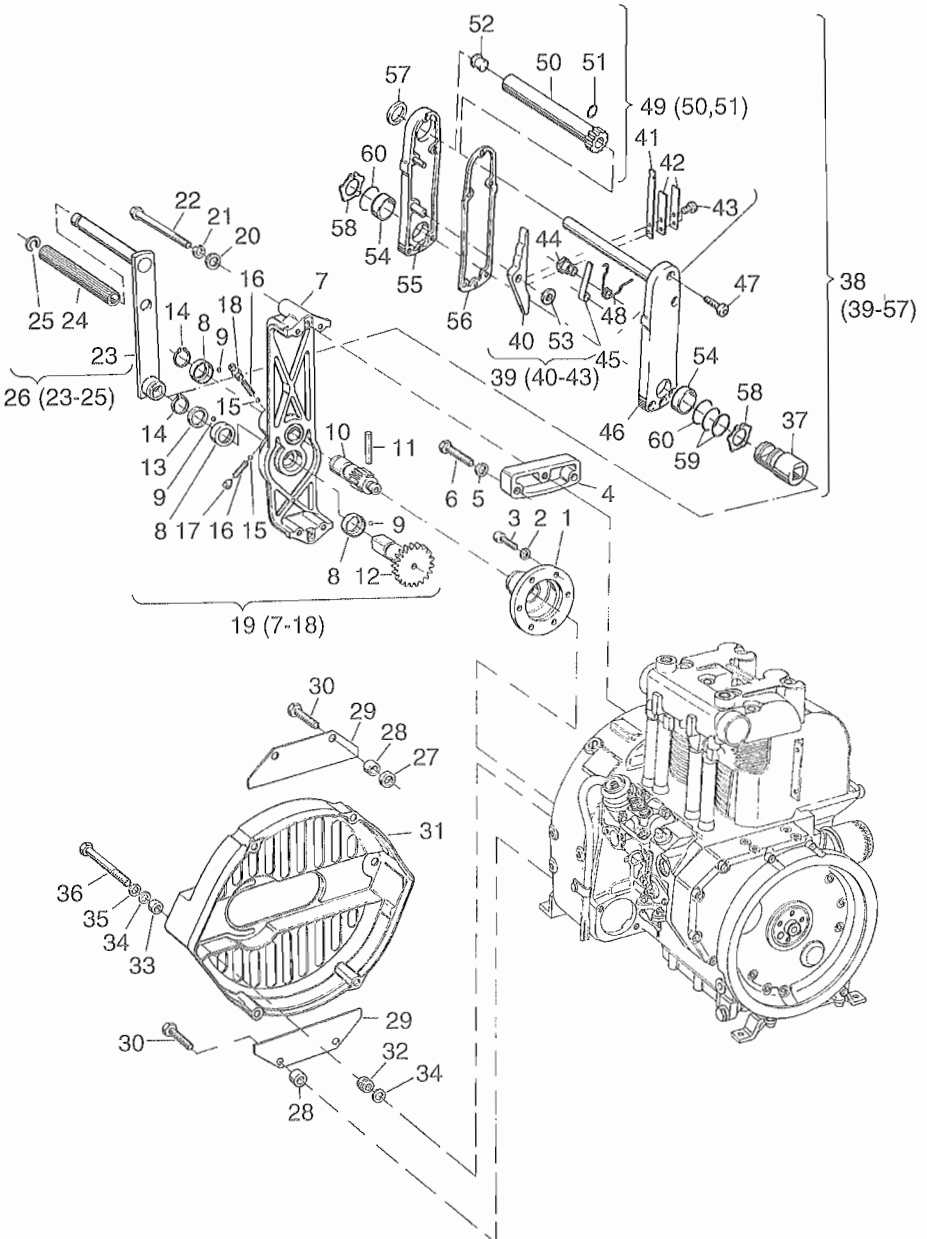

Fig.- No.	HATZ Ident-No.	Stück Qty.			P / W d / D	Bemerkungen Notes
		Z 788	Z 789	Z 790		
1	03269500	1	1	1		
2	50002800	6	6	6	8	DIN 128
3	50052100	6	6	6	M 8 x 25	DIN 912-8.8
4	03269201	2	2	2		
5	50002900	4	4	4	10	DIN 128
6	50029500	4	4	4	M 10 x 40	DIN 933-8.8
7	-----	-	-	-		
8	03175301	3	3	3		
9	50009800	45	45	45	6 mm III	DIN 5401
10	03300000	1	1	1		
11	50009500	1	1	1	8 x 45	DIN 1475
12	03299900	1	1	1		
13	03012401	1	1	1		
14	50020400	2	2	2	24 x 1,2	DIN 471
15	50009800	2	2	2	6 mm III	DIN 5401
16	03159100	2	2	2		
17	03079400	1	1	1		
18	50007800	1	1	1	A M 8 x 1	DIN 71412
19	00526500	1	1	1		
20	50145900	2	2	2	B 10,5	DIN 125-St A3C
21	50002900	2	2	2	10	DIN 128
22	50030400	2	2	2	M 10 x 90	DIN 931-8.8
23	-----	-	-	-		
24	03522400	1	1	1		
25	03515400	1	1	1		
26	00303002	1	1	1		
27	50017100	2	2	2	B 11,5	DIN 7989
28	03354300	4	4	4		
29	03520100	2	2	2		
30	50029600	4	4	4	M 10 x 45	DIN 933-8.8
31	03513700	1	1	1		
32	03665200	6	6	6		
33	03514700	2	2	2		
34	50145900	4	4	4	B 10,5	DIN 125-St A3C
35	50002900	2	2	2	10	DIN 128
36	50030500	2	2	2	M 10 x 100	DIN 931-8.8

A 04

Andrehvorrichtung schs.
Starting device
Dispositif demarrage
Dispositivo de arranque
Dispositivo de avviamento

Tafel Nr.
Tabl.No.
Tavola N.

17

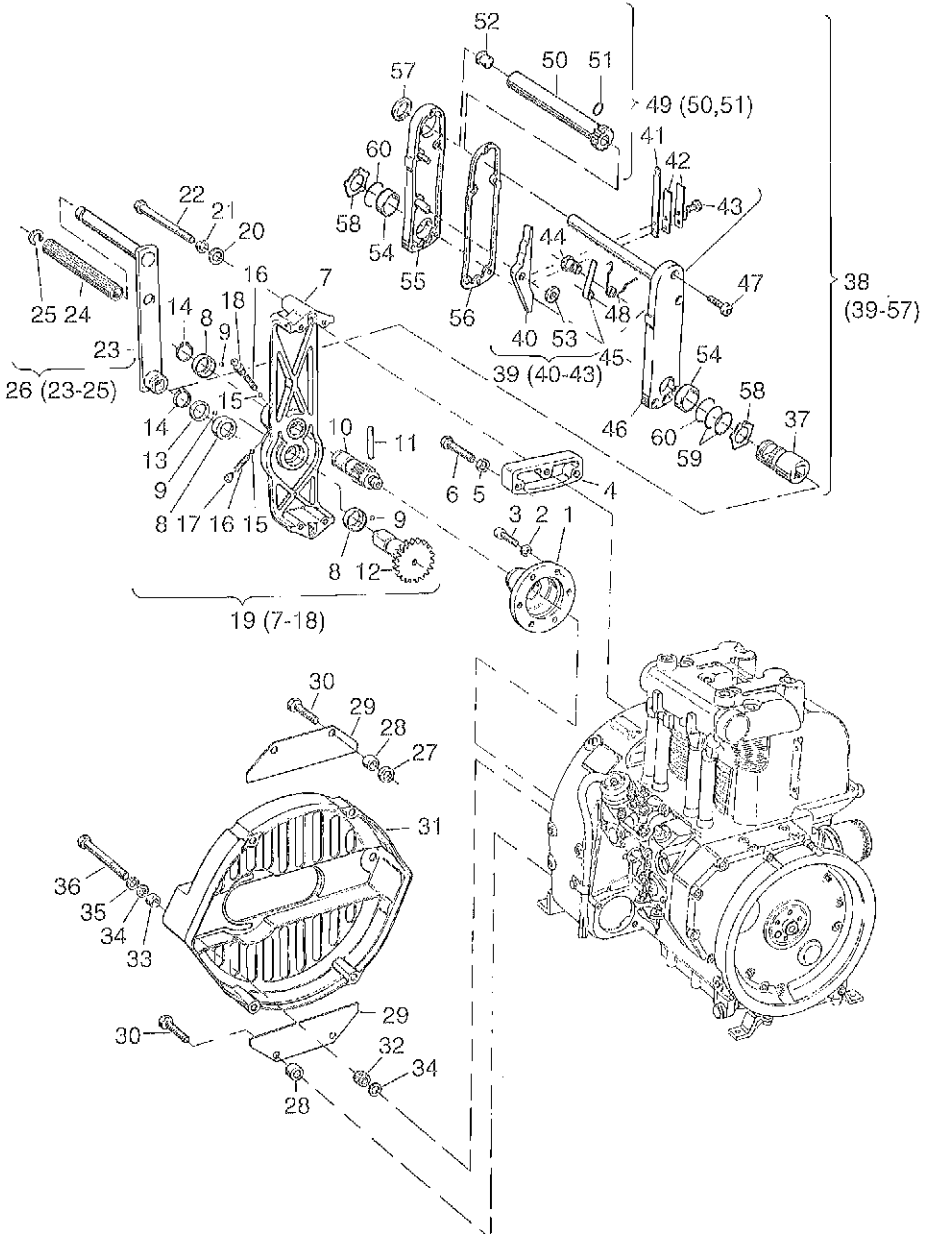

Fig.- No.	HATZ Ident-No.	Stück Qty.			P / W d / D	Bemerkungen Notes
		Z 788	Z 789	Z 790		
37	01018900	1	1	1		
38	01027805	1	1	1		„A“
39	01011404	1	1	1		
40	-----	-	-	-		
41	03812102	1	1	1		
42	03917100	2	2	2		
43	50316500	2	2	2		M 5 x 8 DIN 6912-8.8
44	03955600	1	1	1		
45	03954900	1	1	1		
46	-----	-	-	-		
47	50194400	5	5	5		M 6 x 25 WN 11084 VSK
48	03955900	1	1	1		„A“
49	01011310	1	1	1		
50	-----	-	-	-		
51	50169100	1	1	1		19 x 1,8
52	50199200	1	1	1		V 18
53	50195800	1	1	1		10 x 16 x 0,5 DIN 988
54	50193400	2	2	2		
55	-----	-	-	-		
56	03813000	1	1	1		
57	50194200	1	1	1		28 x 35 x 4
58	50194300	2	2	2		A 30 x 1,5 DIN 983
59	50258500	2	2	2		26 x 1,5
60	03928600	2	2	2		0,15 mm

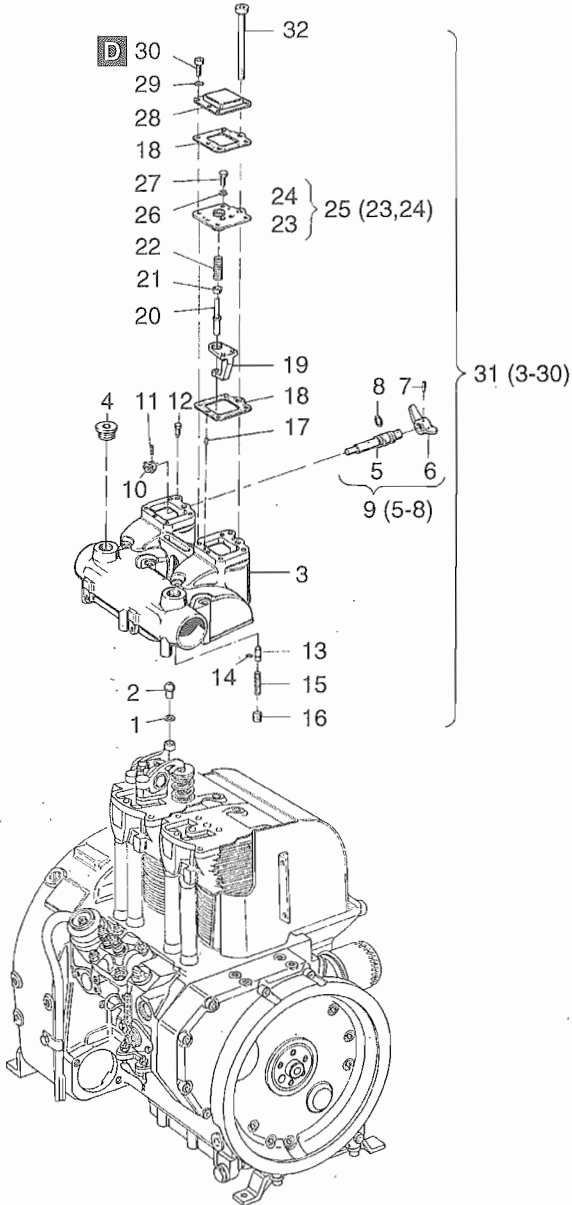

Fig.- No.	HATZ Ident-No.	Stück Qty.			P / W d / D	Bemerkungen Notes
		Z 788	Z 789	Z 790		
1	50123200	2	2	2		5 x 10 x 0,5 DIN 988 ST1K60
2	03451900	2	2	2		
3	-----	-	-	-		
4	50086300	2	2	2		M 20 x 1,5 DIN 908
5	-----	-	-	-		
6	03173401	2	2	2		
7	50034600	2	2	2		4 x 18 DIN 1481
8	40022700	2	2	2	D1	13,3 x 2,4
9	00526801	2	2	2		
10	03051400	2	2	2		
11	50034100	2	2	2		3 x 16 DIN 1481
12	50064900	2	2	2		A M 6 x 16 DIN 561-8.8
13	03299400	2	2	2		
14	50154200	2	2	2		5 x 1
15	03172801	2	2	2		
16	50065000	2	2	2		AM 10 x 10 DIN 913
17	50033900	4	4	4		3 x 8 DIN 1481
18	03334401	4	4	4		
19	03046300	2	2	2		
20	03334301	2	2	2		
21	03045001	2	2	2		
22	03188700	2	2	2		
23	-----	-	-	-		
24	-----	-	-	-		
25	00526702	2	2	2		
26	50002700	4	4	4		6 DIN 128
27	50025400	4	4	4		M 6 x 10 DIN 933-8.8
28	03299301	2	2	2		
29	50002700	10	10	10		6 DIN 128
30	50050800	10	10	10		M 6 x 18 DIN 912-8.8
31	00610710	1	1	1		
32	50064800	2	2	2		M 8 x 120 DIN 912-8.8

A 05

Starter, Generator
Starter, Alternator
Démarreur, Alternateur
Arrancador, Alternador
Motorino avviamento, Alternatore

Tafel Nr.
Tabl.No.
Tavola N.

19

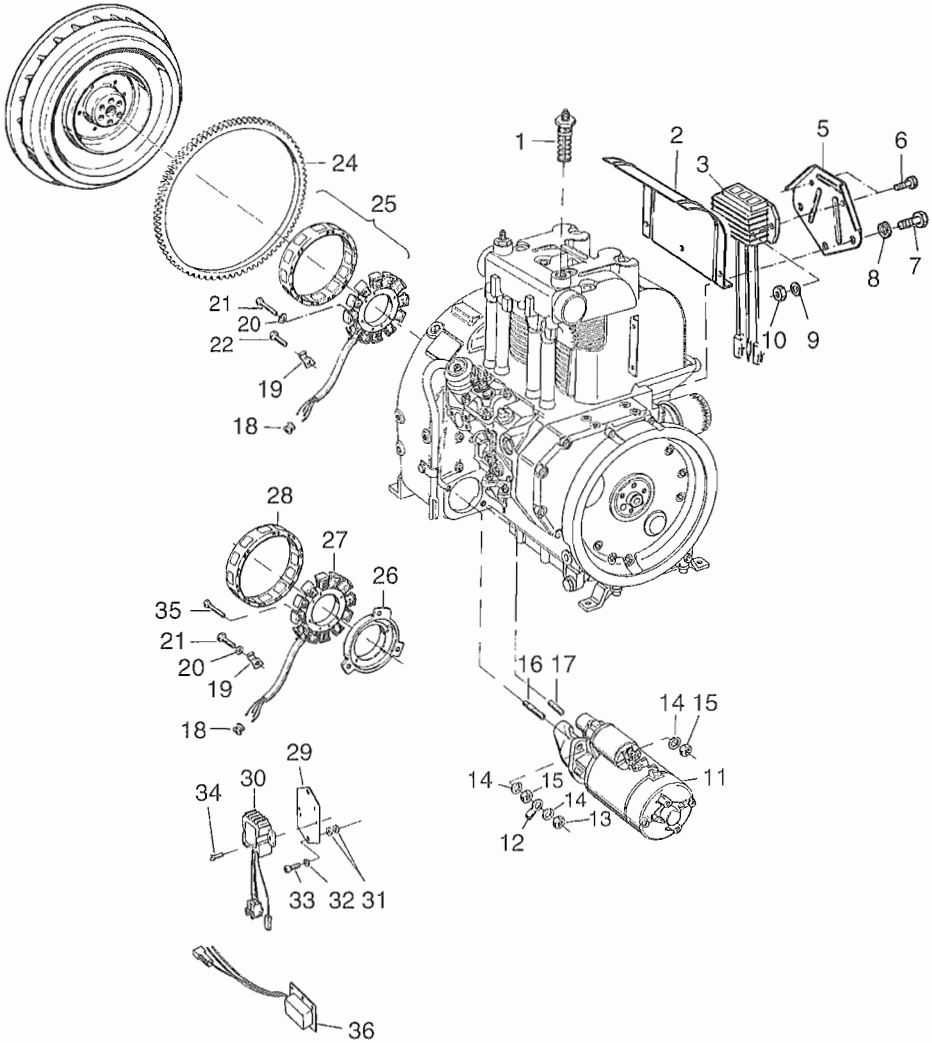

Fig.- No.	HATZ Ident-No.	Stück Qty.			P / W d / D	Bemerkungen Notes
		Z 788	Z 789	Z 790		
1	40068500	1	1	1		
2	03901300	1	1	1		
3	50283811	1	1	1		
4	-----	-	-	-		
5	03897500	1	1	1		
6	50170600	2	2	2	M 6 x 20	DIN 912-8.8 A3C
7	50135700	3	3	3	M 10 x 16	DIN 912-8.8 A3C
8	50135600	3	3	3	10	DIN 128
9	50144500	3	3	3	6,4	DIN 125-St A3C
10	40028300	2	2	2	M 6	SSN 440-8 Cu
11	40000810	1	1	1	12 V - 1,9 kW	
12	50063400	1	1	1		
13	50063500	1	1	1	M 12 A3C	DIN 936-17H
14	50063200	3	3	3	12	DIN 128-A3C
15	50093600	2	2	2	M 12	DIN 934-8 A3C
16	03286800	1	1	1		
17	50042300	1	1	1	M 12 x 25	DIN 939-5.6
18	40043100	1	1	1		
19	03142601	1	1	1		
20	40027700	3	3	3	6	
21	50050700	3	3	3	M 6 x 16	DIN 912-8.8
22	50177100	1	1	1	M 6 x 16	DIN 933-8.8 A3C
23	-----	-	-	-		
24	03217201	1	1	1		
25	50283610	1	1	1		
26	03513400	1	1	1	Syncro	
27	40098301	1	1	1	Syncro	
28	03543800	1	1	1	Syncro	
29	03514101	1	1	1	Syncro	
30	40098501	1	1	1	Syncro	
31	50144500	4	4	4	6,4	DIN 125-St A3C
32	50002700	2	2	2	6	DIN 128
33	50050700	2	2	2	M 6 x 16	DIN 912-8.8
34	50049200	2	2	2	M 4 x 10	DIN 84-4.8 A3C
35	50134800	4	4	4	M 4 x 25	DIN 933-8.8
36	40098601	1	1	1	Syncro	

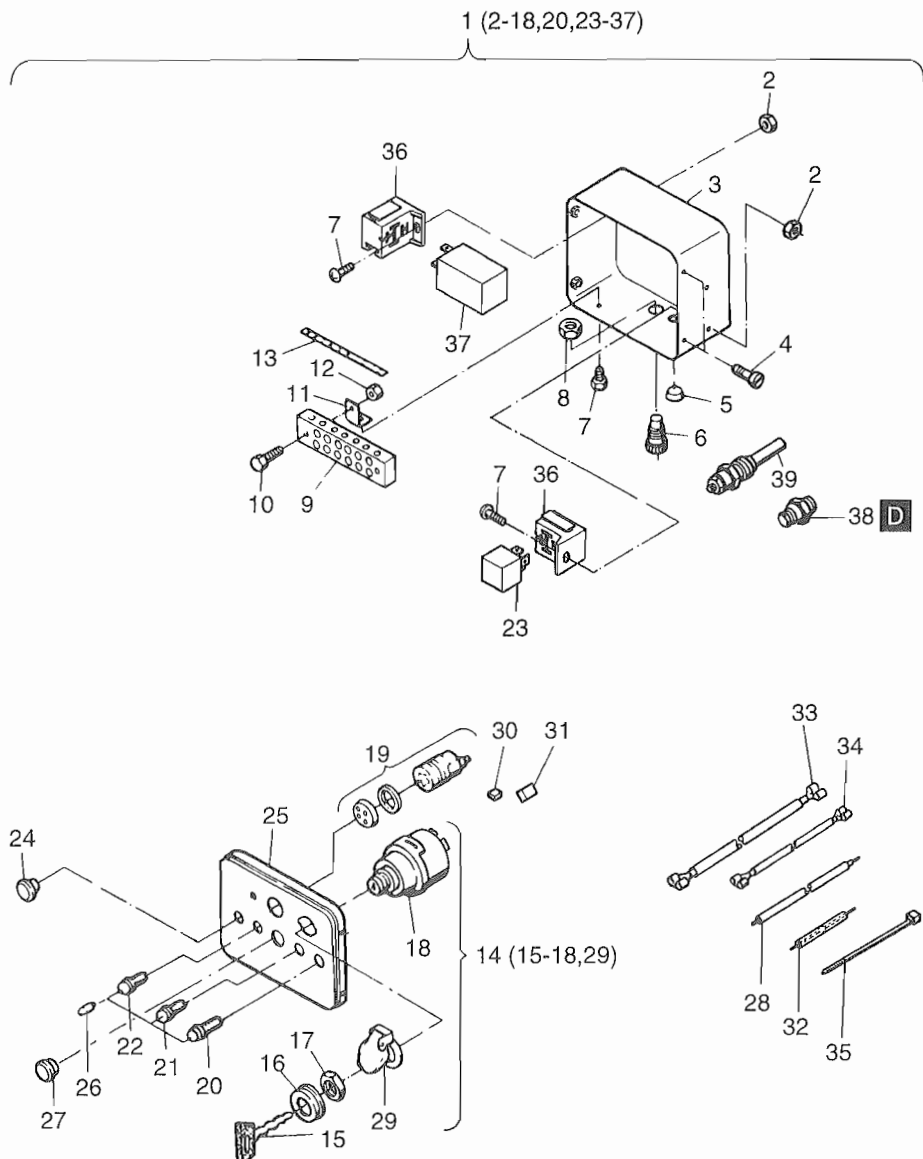

Fig.- No.	HATZ Ident-No.	Stück Qty.			P / W d / D	Bemerkungen Notes
		Z 788	Z 789	Z 790		
1	01112902	1	1	1		12 V
2	40028200	3	3	3		
3	00716311	1	1	1		
4	50289200	4	4	4		M 6 x 12 DIN 8.8 A3D
5	50160800	2	2	2		
6	50159011	1	1	1		
7	50049300	5	5	5		M 5 x 10 DIN 7985-4.8 A3R
8	50159100	1	1	1		
9	50160700	1	1	1		
10	50158800	2	2	2		M 4 x 20 DIN 84-4.8 A3C
11	03666700	2	2	2		
12	50147100	2	2	2		M 4 DIN 934-8 A3C
13	05004300	1	1	1		
14	50276502	1	1	1		
15	50345300	1	1	1	P1	
16	-----	-	-	-		
17	-----	-	-	-		
18	-----	-	-	-		
19	40068600	1	1	1		
20	50176500	1	1	1		BATT
21	50176600	1	1	1		OIL
22	50176400	1	1	1		TEMP.
23	50277701	2	2	2		
24	40096000	3	3	3		F 17
25	03509211	1	1	1		
26	40009700	3	3	3		12 V 2 W
27	40091400	2	2	2		F 24
28	01150101	1	1	1		
29	49050900	1	1	1		
30	50276600	1	1	1		4 - P
31	50276700	1	1	1		6 - P
32	01090201	1	1	1		
33	01089801	1	1	1		
34	01089901	1	1	1		
35	50358400	1	1	1		
36	50276000	3	3	3		
37	50275802	1	1	1		12 V HATZ MSR
38	40021300	1	1	1		OIL
39	50268600	1	1	1		TEMP.

A 07

Öleinfüllung, Ölablaßrohr
Oil filling, Oil drain tube
Remplissage huile, Tube de vidange
Tubuladura, Tubo de purga
Bocchettone introduzione olio, Tubo scarico olio

Tafel Nr.
Tabl.No.
Tavola N.

21

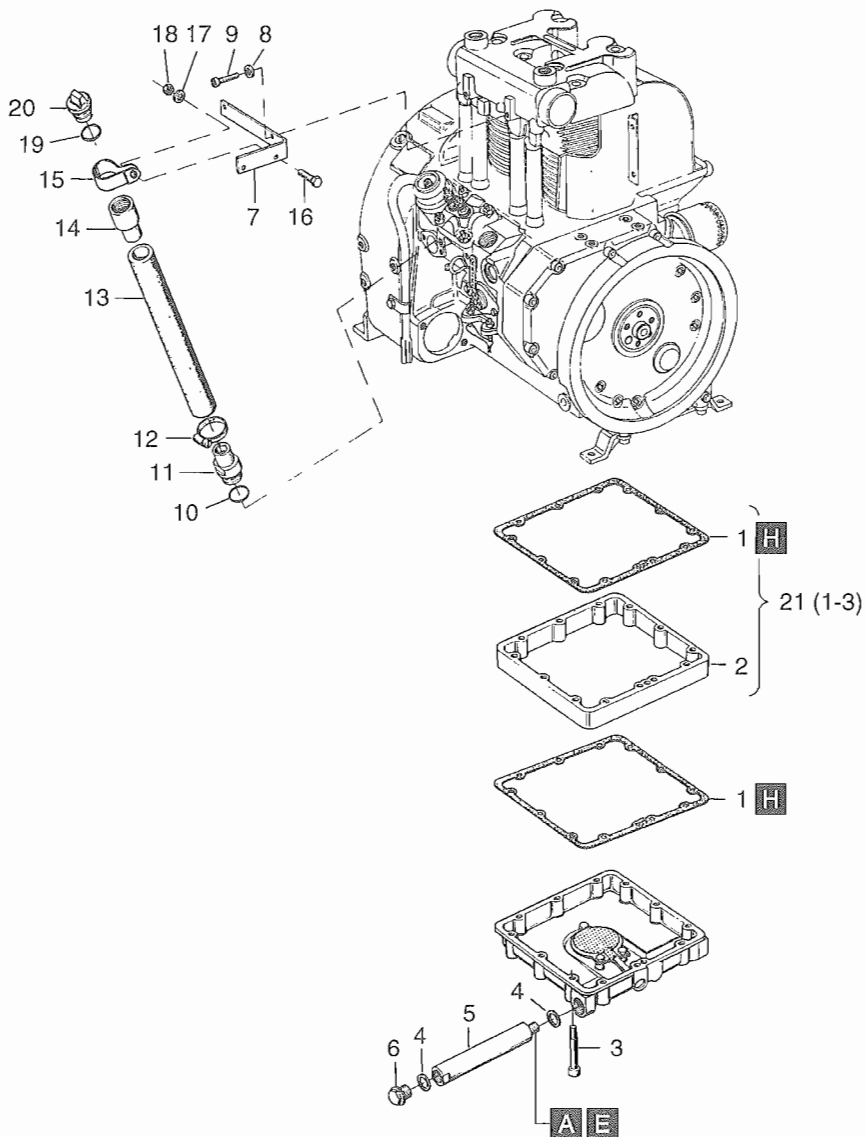

Fig.- No.	HATZ Ident-No.	Stück Qty.			P / W d / D	Bemerkungen Notes
		Z 788	Z 789	Z 790		
1	03212100	2	2	2		
2	-----	-	-	-		
3	50053100	12	12	12	M 8 x 75	DIN 912-8.8
4	50001600	2	2	2	A 22 x 27	DIN 7603-Cu
5	03381600	1	1	1		
6	50044400	1	1	1	CM 22 x 1,5	DIN 7604
7	03472900	1	1	1		
8	50120000	2	2	2	A 6,4	DIN 9021-St Zn
9	50050900	2	2	2	M 6 x 20	DIN 912-8.8
10	50153800	1	1	1	23 x 3	
11	03473100	1	1	1		
12	40086500	1	1	1		
13	40086600	1	1	1		
14	03473000	1	1	1		
15	40086400	1	1	1		
16	50026700	1	1	1	M 8 x 16	DIN 933-8.8
17	50148100	1	1	1	8,4	DIN 125-St A3C
18	50022900	1	1	1	M 8	DIN 934-8
19	50153800	1	1	1	23 x 3	
20	03069004	1	1	1		
21	00687800	1	1	1		

A 10

Absperrventil
Shut off valve
Soupape d'arrêt
Valvula de parada
Valvola di arresto

Tafel Nr.
Tabl.No.
Tavola N.

22

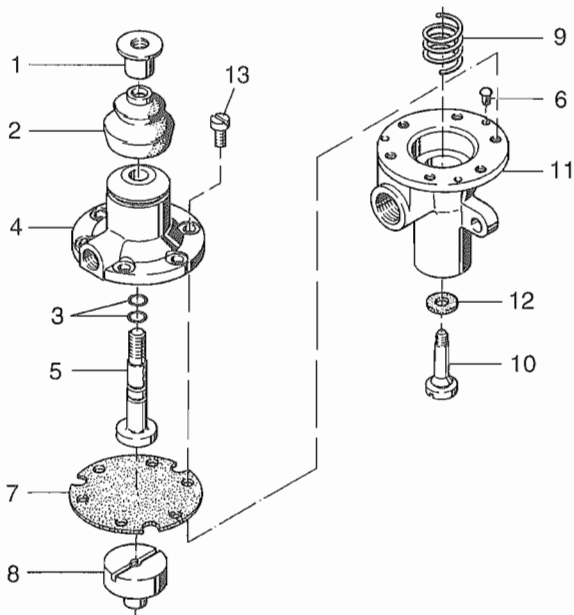

Fig.- No.	HATZ Ident-No.	Stück Qty.			P / W d / D	Bemerkungen Notes
		Z 788	Z 789	Z 790		
1	03535900	1	1	1		
2	50248900	1	1	1		
3	50167000	2	2	2		
4	03692200	1	1	1		
5	03692000	1	1	1		
6	-----	-	-	-		
7	03692100	1	1	1		
8	03691800	1	1	1		
9	03691400	1	1	1		
10	03691200	1	1	1		
11	03692300	1	1	1		
12	03691300	1	1	1		
13	50049200	6	6	6		M 4 x 10 DIN 84-4.8 A3C

A 16

Wellenstummel, elastische Kupplung
Stubshaft, flexible coupling
Bout d'arbre, Accouplement elastique
Eje, Acoplamiento elastico
Contralbero, Giunto elastico

Tafel Nr.
Tabl.No.
Tavola N.

23

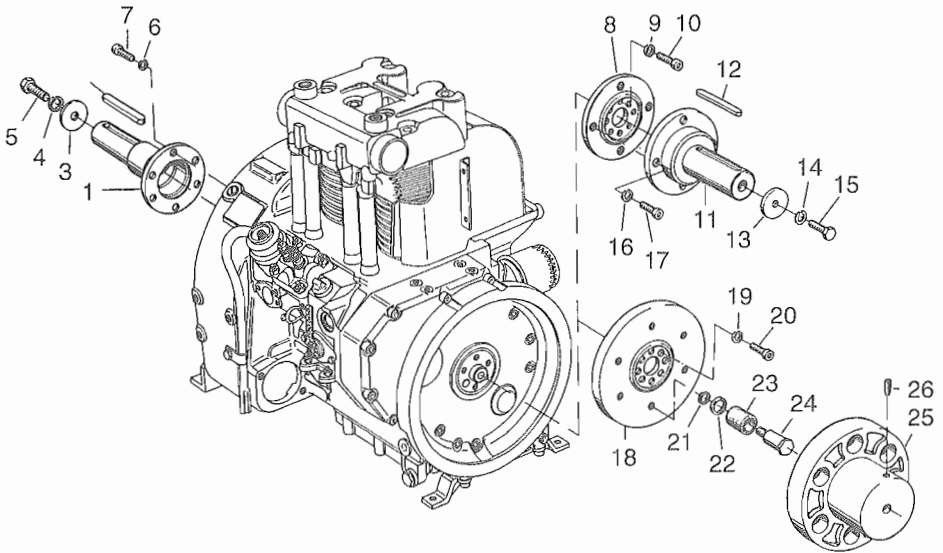

Fig.- No.	HATZ Ident-No.	Stück Qty.			P / W d / D	Bemerkungen Notes
		Z 788	Z 789	Z 790		
1	03360000	1	1	1		
2	50081400	1	1	1		A 12 x 8 x 100 DIN 6885
3	03480200	1	1	1		
4	50003000	1	1	1	12	DIN 128
5	50031200	1	1	1	M 12 x 30	DIN 933-8.8
6	50002800	6	6	6	8	DIN 128
7	50052100	6	6	6	M 8 x 25	DIN 912-8.8
8	03282300	1	1	1		
9	50002900	8	8	8	10	DIN 128
10	50053800	8	8	8	M 10 x 25	DIN 912-8.8
11	03282200	1	1	1		
12	50062600	1	1	1		A 14 x 9 x 100 DIN 6885
13	03480200	1	1	1		
14	50003000	1	1	1	12	DIN 128
15	50031200	1	1	1	M 12 x 30	DIN 933-8.8
16	50002900	4	4	4	10	DIN 128
17	50053800	4	4	4	M 10 x 25	DIN 912-8.8
18	03115000	1	1	1		
19	50002900	8	8	8	10	DIN 128
20	50053800	8	8	8	M 10 x 25	DIN 912-8.8
21	50061600	6	6	6	12	DIN 7980
22	03079000	6	6	6		
23	03151000	6	6	6		
24	03046900	6	6	6		
25	03040500	1	1	1		
26	50004600	1	1	1		AM 8 x 15 DIN 916-10.9

Hydraulik Ölkühler, Anbauteile Hydr.-Pumpe

Oil cooler, Parts hydr. pump

Tafel Nr.

Tabl.No.

A 18

Refroidisseur huile, Piece-mount. pompe hydr.

Radiador de aceite, Piezas mont. bomba

Radiatore olio, Particolari per montaggio pompa idraulica

24

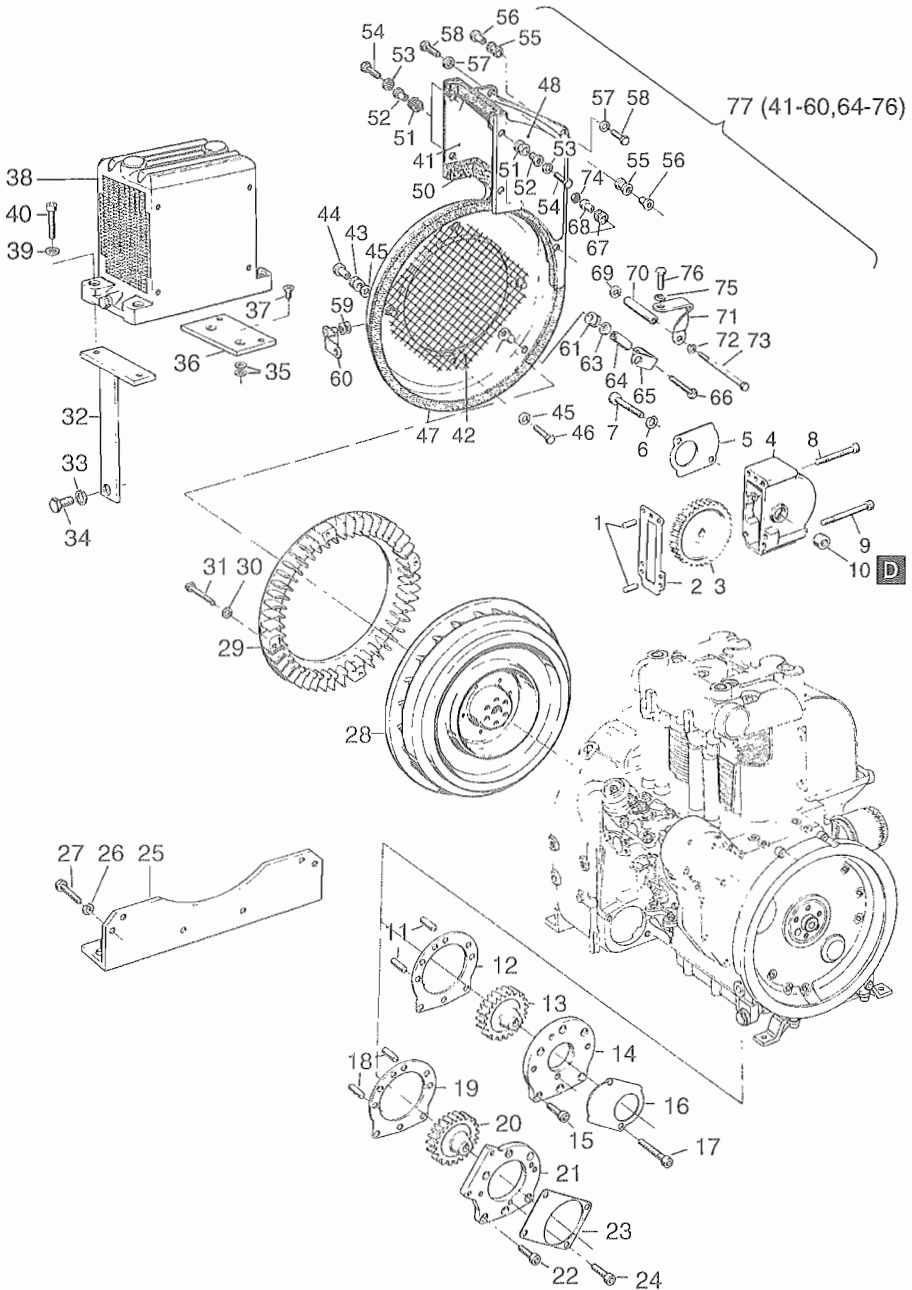

Fig.- No.	HATZ Ident-No.	Stück Qty.			P / W d / D	Bemerkungen Notes
		Z 788	Z 789	Z 790		
1	50058400	2	2	2		8 m 6 x 20 DIN 7 - 9S20k
2	03270400	1	1	1		
3	03233900	1	1	1		
4	03233800	1	1	1		
5	03270300	1	1	1		
6	50002900	2	2	2	10	DIN 128
7	50054700	2	2	2	M 8 x 75	DIN 912-8.8
8	50053100	2	2	2	M 10 x 45	DIN 912-8.8
9	50059700	2	2	2	M 8 x 100	DIN 912-8.8
10	50059500	1	1	1	M 30 x 1,5	DIN 906
11	50058400	2	2	2		8 m 6 x 20 DIN 7 - 9S20k
12	03270200	1	1	1		
13	03114300	1	1	1		
14	03114201	1	1	1		
15	50052000	6	6	6	M 8 x 20	DIN 7 - 9S30k
16	03270300	1	1	1		
17	50054600	2	2	2	M 10 x 40	DIN 912-8.8
18	50058400	2	2	2		8 m 6 x 20 DIN 7 - 9S20k
19	03270200	1	1	1		
20	03494300	1	1	1		
21	03358200	1	1	1		
22	50052000	6	6	6	M 8 x 20	DIN 6912-8.8
23	03420000	1	1	1		
24	50052000	4	4	4	M 8 x 20	DIN 6912-8.8
25	03428900	1	1	1		
26	50002900	6	6	6	10	DIN 128
27	50029200	6	6	6	M 10 x 25	DIN 933-8.8
28	03428801	1	1	1		
29	03030300	1	1	1		
30	50148100	4	4	4	8,4	DIN 125-St A3C
31	50027700	4	4	4	M 8 x 40	DIN 931-8.8
32	00652502	1	1	1		
33	50061600	1	1	1	12	DIN 7980
34	50031000	1	1	1	M 12 x 25	DIN 125-St A3C
35	50145900	4	4	4	B 10,5	DIN 125 - ST
36	03543600	1	1	1		
37	40026900	2	2	2		
38	40088800	1	1	1		
39	50145900	4	4	4	B 10,5	DIN 125-St A3C

Hydraulik Ölkühler, Anbauteile Hydr.-Pumpe
Oil cooler, Parts hydr. pump

Tafel Nr.
Tabl.No.
Tavola N.

A 18

Refroidisseur huile, Piece-mount. pompe hydr.
Radiador de aceite, Piezas mont. bomba
Radiatore olio, Particolari per montaggio pompa idraulica

24

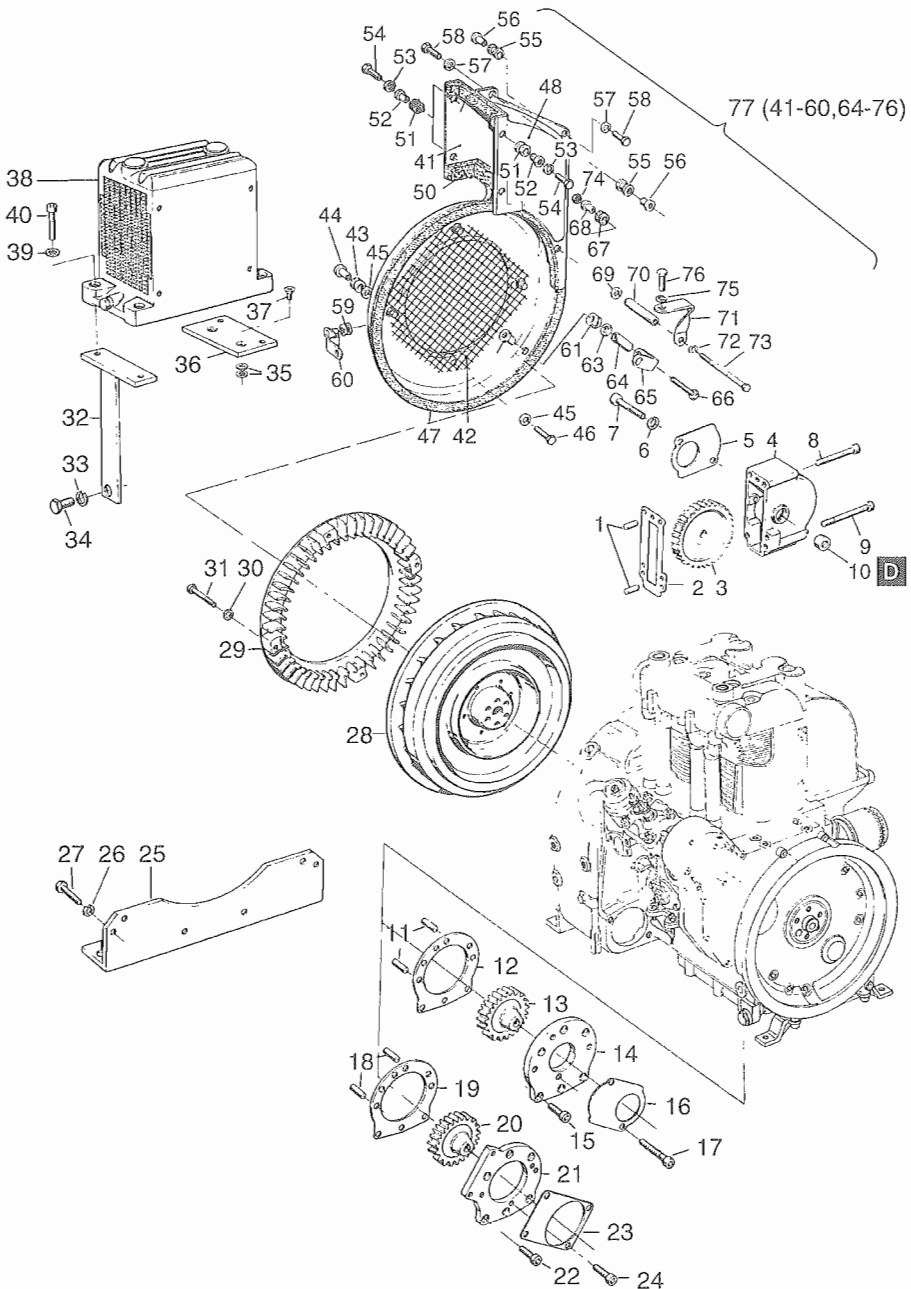

Fig.- No.	HATZ Ident-No.	Stück Qty.			P / W d / D	Bemerkungen Notes
		Z 788	Z 789	Z 790		
40	50054600	4	4	4	M 10 x 40	DIN 912-8.8
41	03514300	1	1	1		
42	03543100	1	1	1		
43	03665200	4	4	4		
44	03535900	4	4	4		
45	50114300	8	8	8	6,4	DIN 7349
46	50025800	4	4	4	M 6 x 20	DIN 933-8.8
47	03676600	1	1	1		
48	03514800	1	1	1		
49	03676500	1	1	1		
50	03676400	1	1	1		
51	03665200	3	3	3		
52	03528300	3	3	3		
53	50002800	3	3	3	8	DIN 128
54	50026800	3	3	3	M 8 x 20	DIN 933-8.8
55	40043100	2	2	2		
56	03535900	2	2	2		
57	50114300	2	2	2	6,4	DIN 7349
58	50025700	2	2	2	M 6 x 16	DIN 933-8.8
59	03665200	1	1	1		
60	00786100	1	1	1		
61	03665200	1	1	1		
62	03535900	1	1	1		
63	50114300	1	1	1	6,4	DIN 7349
64	03042700	1	1	1		
65	03543400	1	1	1		
66	50026300	1	1	1	M 6 x 35	DIN 931-8.8
67	03665200	1	1	1		
68	03377600	1	1	1		
69	50114300	1	1	1	6,4	DIN 7349
70	03662800	1	1	1		
71	03543500	1	1	1		
72	50002700	1	1	1	6	DIN 128
73	50155100	1	1	1	M 6 x 75	DIN 931-8.8
74	50144400	1	1	1	M 6	DIN 934-8 A3C
75	50002900	1	1	1	10	DIN 128
76	50029000	1	1	1	M 10 x 16	DIN 933-8.8
77	01248600	1	1	1		

Anhang für nicht abgebildete Zusatzausrüstung:

Weitere Zusatzausrüstungen können aus Platzgründen in der Ersatzteilliste nicht mehr detailliert dargestellt werden. Für die Bestellung von Teilen aus nicht abgebildeten Zusatzausrüstungen verwenden Sie bitte nachfolgende Übersicht. Anhand der Skizze ist die gesuchte Zusatzausrüstung auffindbar, die für den jeweiligen Motortyp zugehörige Ident-Nr. der Ausrüstung ist aus der Tabelle ersichtlich.

Ihre zuständige HATZ-Vertretung kann Ihnen anhand dieser Ident-Nr. das gewünschte Ersatzteil heraussuchen.

Annex for additional equipment which is not illustrated:

Due to lack of space we cannot list further additional equipment in our parts list: For parts ordering not illustrated, please use the below listed survey. With the aid of sketches you can find the required additional equipment. The ident-number belonging to the corresponding engine type can be taken from the table. Your HATZ agent is in a position to select for you the required spare part as soon as you have selected the correct ident-number.

Annexe concernant les accessoires complémentaires non-illustrés:

Un certain nombre d'accessoires complémentaires n'ont pu, par suite d'un manque de place, être représentés d'une manière détaillée dans la liste de pièces détachées. Pour la commande de ces accessoires, qui ne sont pas illustrés, veuillez utiliser l'aperçu ci-après. A l'aide des croquis, il est possible de trouver l'accessoire souhaité, le No. ident. correspondant pour chaque type de moteur figure dans le tableau. Grâce à ce No. ident. votre représentant HATZ pourra vous trouver la pièce souhaitée.

En relación a equipos adicionales no ilustrados:

Debido a razones de espacio no es posible ilustrar otros equipos adicionales en la lista de piezas. Para pedidos de equipos adicionales no ilustrados favor usen la siguiente orientación. A base de las ilustraciones es posible encontrar el equipo adicional buscado, el número ident para el tipo de motor para el cual se necesita el equipo se puede obtener de la tabla. El representante HATZ para su area puede entonces a base del número ident encontrar las piezas deseadas.

Allegato concernente gli accessori complementari non illustrati:

Un certo numero di accessori complementari non sono stati inseriti in modo dettagliato sul catalogo ricambi per mancanza di spazio. Per effettuare un ordine di questi accessori vogliate utilizzare le tavole che seguono. Con l'aiuto dei disegni è possibile trovare il pezzo desiderato, ed il codice corrispondente per ogni tipo di motore. Con il codice del pezzo il vostro concessionario HATZ potrà soddisfare la vostra richiesta.

Zusatz-ausrüstungen

Equipements

Accessoires complémentaires

Accessori complementari

Equipos

Code

Ident-No.

Z 788

Z 789

Z 790

Bemerkungen

Notes



A 10.70

00886700

X

X

X

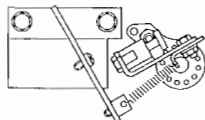

A 11.10

00560104

X

X

X

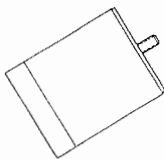

A 11.10

00843802

X

X

X

12 V

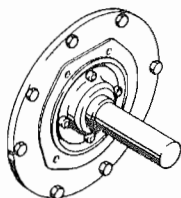

A 15.20

01132500

X

X

X

SAE B5

A 16.20

01132900

X

X

X

SAE B5

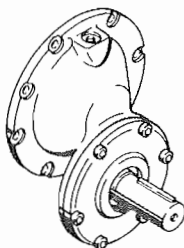

A 20.10

00655900

X

X

X

i = 2

Zusatzrüstungen
 Equipements
 Accessoires complémentaires
 Accessori complementari
 Equipos

Bemerkungen
 Notes

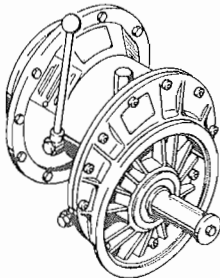
	Code	Ident-No.	Z 788	Z 789	Z790	
	A 20.11	00662601	X	X	X	1.36 : 1
	A 20.11	00661501	X	X	X	i = 1.36
	A 20.11	00662501	X	X	X	i = 1.73
	A 21.11	00663401	X	X	X	i = 1.37 ld
	A 21.11	00663501	X	X	X	i = 1.75 ld
	A 21.11	00662701	X	X	X	i = 4.10 ld
	A 21.11	00662801	X	X	X	i = 5.19 ld

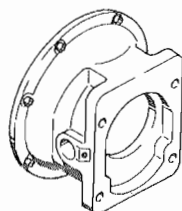

A 20.60	00582000	X	X	X
---------	----------	---	---	---

Serien-Nr.-Änderungen
Serial-code modification list
Modification des Nos de serien
Modificación de los Nos de serie
Modifica dei codici

IMT.-No.

Z 788.14	Z 788.15	87.474
Z 789.14	Z 789.15	87.474
Z 790.14	Z 790.15	87.474
Z 788.15	Z 788.16	98.581
Z 789.15	Z 789.16	98.581
Z 790.15	Z 790.16	98.581

